



# Acer Wave 7 Wi-Fi Mesh Router

## User Manual

### V1.0

All Rights Reserved. © 2024.

**Important:** This manual contains proprietary information that is protected by copyright laws. The information contained in this manual is subject to change without notice. Some features described in this manual may not be supported depending on the Operating System version. Images provided herein are for reference only and may contain information or features that do not apply to your device. Acer Group shall not be liable for technical or editorial errors or omissions contained in this manual.

Revision Jul, 2024

# Contents

1. Overview.....	3
2. Installation and Setup.....	3
3. Initial Configuration.....	6
4. Dashboard.....	7
5. Hybrid QoS.....	10
6. Quick Setup.....	12
6.1 How to create a Mesh network.....	12
6.2 Mesh topologies.....	13
7. WAN.....	16
7.1 WAN status.....	16
7.2 WAN setting.....	16
7.3 DMZ.....	16
7.4 WAN ping.....	17
7.5 Firewall.....	17
7.6 Port forwarding.....	17
7.7 VPN server.....	18
7.8 DDNS.....	18
8. Wi-Fi.....	19
8.1 Wi-Fi Status.....	19
8.2 MLO Settings.....	19
8.3 Mesh Wi-Fi.....	19
8.4 Wi-Fi MAC filter.....	20
8.5 Smart home Wi-Fi.....	20
8.6 Guest Wi-Fi.....	20
8.7 ACS.....	20
9. LAN.....	21
10. IPv6.....	22
11. Home Network Security.....	22
11.1 Network Security Setting.....	22
11.2 Parental Control.....	23
12. System.....	24
12.1 Operation mode.....	24
12.2 Login password.....	25
12.3 System time.....	25
12.4 Languages.....	25
12.5 Backup and restore.....	25
12.6 System Information.....	26
12.7 Restart and Reset default.....	26
12.8 Firmware update.....	26
12.9 System logs.....	27
12.10 Main LED.....	27
13. App download.....	28
14. Troubleshooting.....	29
13.1 Quick Tips.....	29
13.2 FAQs (Frequently Asked Questions).....	29
15. Appendix factory default settings.....	30
16. Router Basic Specification.....	31
17. Regulatory Information.....	33

# 1. Overview

The Acer Wave 7 is a state-of-the-art dual-band BE6400 Wi-Fi 7 wireless router, featuring a user-friendly setup process via a Quick Setup Wizard. It supports 2.4GHz + 5GHz or 2.4GHz + 6GHz configurations, maximizing the potential of Wi-Fi 7 technology for optimal data transmission and minimal latency. Wi-Fi 7's Multi-Link Operation (MLO) significantly enhances throughput, reduces latency, and improves network efficiency, depending on the compatibility of the router and your wireless devices.

Acer Wave 7 supports automated mesh setup, allowing seamless connectivity across multiple routers, and offers flexible Mode switching for each router to enhance usability. Additional features include port forwarding profiles, Hybrid QoS for efficient bandwidth utilization, and a VPN feature for secure internet browsing. The Acer Wave 7 boasts a sleek, modern design with a minimalist aesthetic, discreet LED indicators, and strategically placed ventilation, making it an attractive and functional addition to any home or office.

Acer Wave 7 offers three packaging options for purchase: 1-pack, 2-pack, and 3-pack. In the 2-pack and 3-pack options, Acer Wave 7 features a new capability to automatically form a mesh network upon plugging in. Therefore, in these packages, you will see that one router is pre-configured as the Controller, while the others are set as Agents.

## Important:

Each router inside 1-pack, 2-pack and 3-pack options has different operation modes, which are used to form the mesh network. You can log in Web UI to confirm or change the operation modes.

# 2. Installation and Setup

2.1. Plug in the AC adapter and turn the router power button ON located at the bottom of the device.

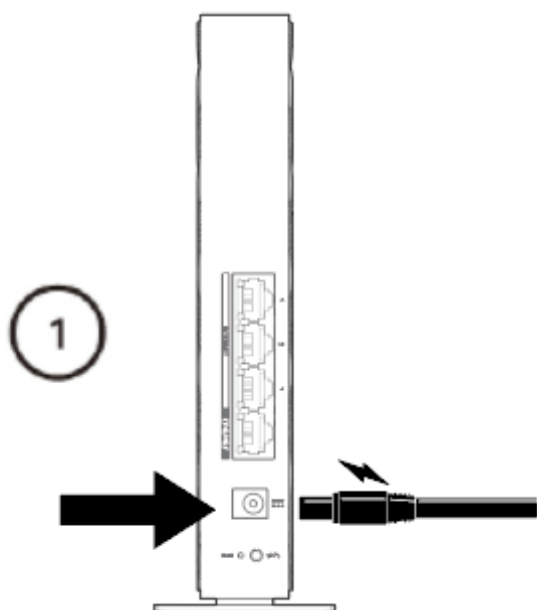

2.2. Plug into an outlet.

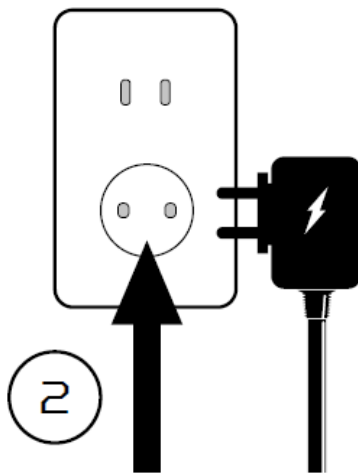

2.3 Plug-in Internet cable.

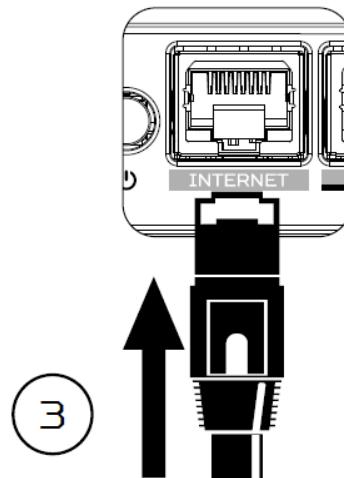

2.4 Connect to Acer WAVE 7 Wi-Fi.

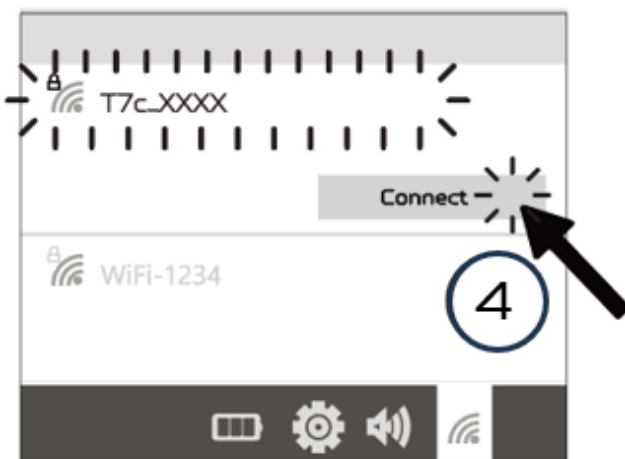

2.5 Important info is at the back of the device

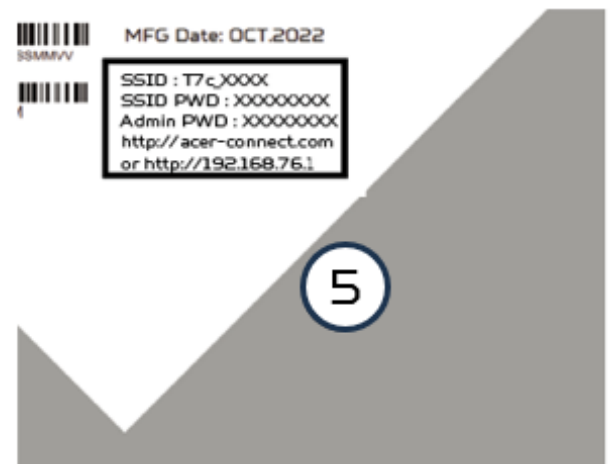

2.6 The device can be either setup via Predator Connect mobile App or the browser web admin.

How to setup the router via **Predator Connect Mobile App**:

- Use a mobile device camera to scan the QR code below. Download the Predator Connect mobile App via Play Store or App Store.



- Open the Predator Connect Mobile App and follow the steps for registering an account. Go to your email inbox, review the registration email, and input the 4-digit registration code onto the mobile App. When the whole process is completed, you will be automatically signed in.
- Enable the mobile Wi-Fi function and scan the device QR-code printed on the back label. The default admin and Wi-Fi password will be automatically exported into the mobile app. (SSID: T7c\_YYYY)
- Device setup completed.

**Setup the router via browser:**

- Please make sure that the wireless function on your laptop is already enabled.
- Check the device's back label, and find the router's default SSID (T7c\_XXXX) and password and then connect.
- Open the browser on your laptop/desktop, input the device web admin URL: <http://acer-connect.com> or IP: http://192.168.76.1
- The device will automatically redirect to a quick setup wizard. Follow the easy 1-2-3 steps and get ready to access the internet.

Note: The admin login password requires modification within the setup wizard for first-time use. Please create a strong password and keep it in a safe place. (New password cannot be the same as the prior one.)

Note: The router web admin portal will automatically lock after five consecutive incorrect attempts. You have to power cycle the router to unlock the web admin.

Note: The SSID Wi-Fi password can't be the same as the admin login password.

Both App & browser can help router to do quick setup. Web UI can execute all functions and settings of router. Mobile App allows the user to remotely control some functions of the router and receive notifications.

# 3. Initial Configuration

Please log in to the Acer Wave 7 Web Portal (<http://acer-connect.com> or IP: <http://192.168.76.1>) by using the current valid Admin password. You can select the language of Web UI by clicking on the drop-down arrow.

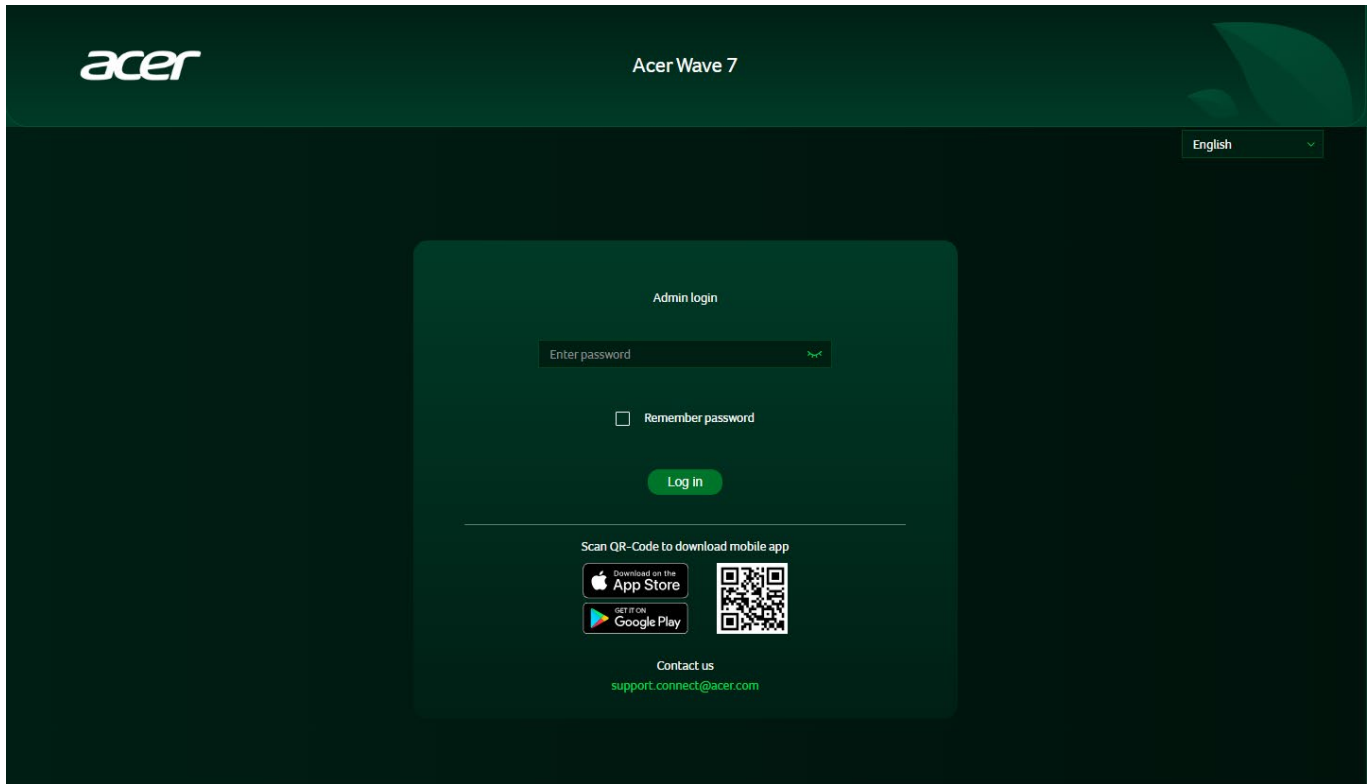

Please enter your login password to access the dashboard and settings of your Acer Wave 7. The router will provide step-by-step instructions to help you set up and configure your internet access and basic network settings.

You can also scan the QR code on the login screen using your Android or iPhone to download the mobile app for remote router management.

# 4. Dashboard

After logging in successfully, the Acer Wave 7 dashboard will display the following key information.

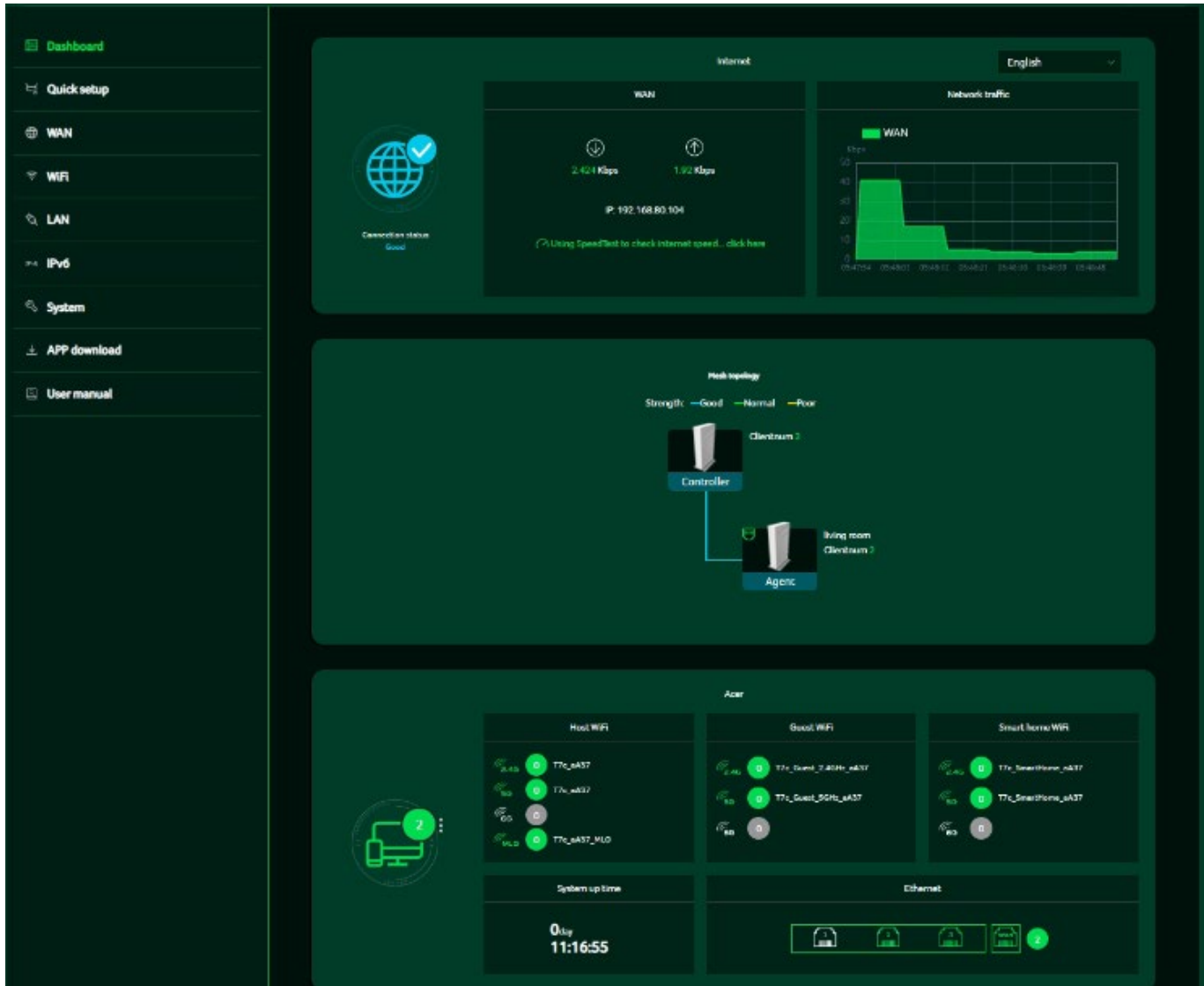

**Connection Status:** displays the current status of your Internet connection.

**WAN Status :** displays WAN connectivity, download/upload speeds, and the WAN IP address.

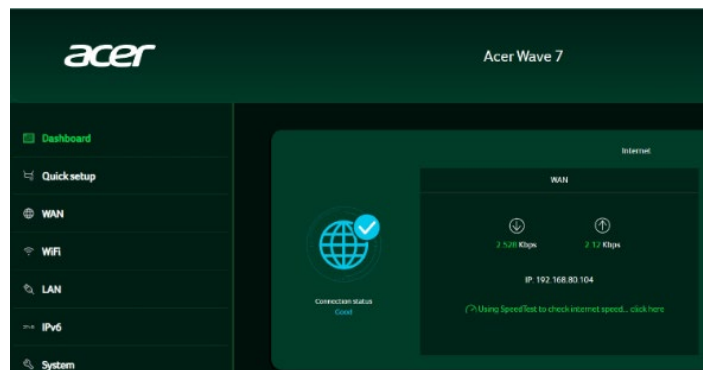

**Wi-Fi Status:** displays the number of wireless client devices connected to the 2.4GHz, 5GHz, or 6GHz bands. When you purchase a mesh pack, the default Wi-Fi settings will be 2.4GHz +5GHz, and both band steering and MLO will be automatically enabled. In this case, the SSID will display as T7c\_xxxx and T7c\_xxxx\_MLO. When you purchase a single pack, the default Wi-Fi settings will be 2.4GHz and 5GHz, and the SSID will display as T7c\_xxxx\_2.4GHz and T7c\_xxxx\_5GHz.



**LAN Status:** quickly indicates the status of LAN ports. The Acer Wave 7 has one WAN port, one Game port, and one LAN port. The “icon” on the far right represents the number of devices connected to the Wave 7 router. Clicking on this icon will display the table shown below.

**System Uptime:** display the system Uptime since the last reboot.

**Connected Devices:** displays the number of client devices connected to your Wave 7 via Wi-Fi or LAN. You can modify a device's name by clicking on the pencil icon.

This tab shows the client device name, IP address assigned by the router, MAC address, connection mode (Ethernet or Wi-Fi), and the duration of the device's connection to the router. You can also block a device from accessing the Internet by clicking the "block" button.

Connected devices

Connected devices - Host WiFi and others (2)

Device name	IP address	MAC address	Connection	Duration	Edit
LAPTOP-0B13NJB9	192.168.76.100	00:0e:c6:f3:64:d0	Ethernet	11:20:26	Block
T7c	192.168.76.101	70:5a:0f:5a:75:48	Ethernet	11:15:23	Block

Connected devices - Guest WiFi (0)

Device name	IP address	MAC address	Connection	Duration	Edit
-------------	------------	-------------	------------	----------	------

Connected devices - Smart home WiFi (0)

Device name	IP address	MAC address	Connection	Duration	Edit
-------------	------------	-------------	------------	----------	------

Blocked devices (0)

Device name	MAC address	Edit
-------------	-------------	------

Agent(70:5a:0f:5a:75:48(2))

Device name	IP address	MAC address	Connection	Duration	Edit
	192.168.76.1	70:5a:0f:5a:76:04	Ethernet	11:14:11	Block
LAPTOP-0B13NJB9	192.168.76.100	00:0e:c6:f3:64:d0	Ethernet	11:14:11	Block

### Network Traffic:

indicates the real-time status of the download (DL) and upload (UL) speeds across the WAN.

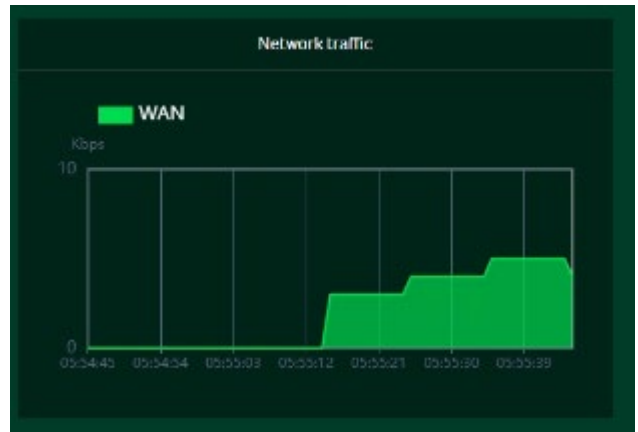

### Network Speed Test:

1. Powered by Ookla. Pressing the "GO" button tests the speed of the WAN connectivity.
2. You can manually select a server by clicking on the dropdown arrow to display available servers.
3. Clicking the "GO" button will test the network speed and display the results as shown in the image below.

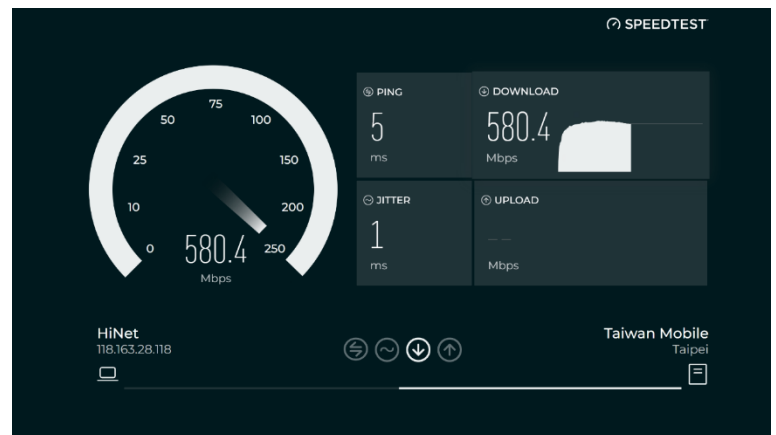

It will test and clearly display the network download and upload speeds in Mbps, ping rate, and jitter in milliseconds. After viewing the speed test results, you have the option to run the test again.

# 5. Hybrid QoS

Hybrid QoS integrates both application and device prioritization. A Killer-Enabled PC can assign priority to applications and send packets with DSCP values to the Acer Wave 7 router. The router will then classify these packets and prioritize different applications according to the definitions below.

For devices without Killer support, the Acer Wave 7 can recognize game consoles, streaming devices, computers, smartphones, and IoT devices on the network. It will allocate priority groups based on default settings, or users can manually adjust the priority for connected devices.

\*Note: Device identification requires the network security engine to be enabled.  
Application-Based QoS Priority: (Enabled by default)

\*Note: Application Priority uses the DSCP value in the IP header for packet classification. Laptops and desktops with Killer™ technology categorize traffic into four priority levels: Extreme (Games), High (Streaming), Normal (Browsing), and Low (Download).

Priority	Extreme(Games)	High(Streaming)	Normal(Browsing)	Low(Download)
Applications (DSCP)	Killer Priority 1 (Games) Killer Priority 2 (Real Time)	Killer Priority 3 (Streaming)	Killer Priority 4 (Browsing)	Killer Priority 5 & 6 (Cloud Download)
Intel Killer Teams/Zoom, GT-Booster	Teams/Zoom Voice	Teams/Zoom Video	Teams Shared Shared Screen	
Devices	Game Port Connected Game Console: PS, Xbox, Switch	Chromecast, FireTV, Roku SmartTV	Computers, Smartphones Other Devices	IoT Devices, Wearable

### Device priority:

Note 1: A Killer-Enabled PC is automatically set to extreme priority, whether connected via wired Ethernet or wireless.

Note 2: You can drag and drop connected clients into the desired priority level, and the changes will take effect immediately.



To configure upload and download **bandwidth**, please contact your ISP for the exact values. Once the bandwidth is set, QoS will allocate it according to the weighting percentage of each priority queue.

**Bandwidth**

For the upload and download bandwidth configuration, please contact your ISP to get the exact value of upload and download bandwidth. Or please connect to speed test website and check the bandwidth result in your network. After the bandwidth is configured, QoS will reserve the bandwidth according to the weighting percentage for each priority queue.

Use default configuration  Setting manually

Upload bandwidth:  Mbps

Download bandwidth:  Mbps

Priority weighting: Extreme:  % High:  % Normal:  % Low:  %

Cancel Apply

You may select “use default configuration” and click on “Apply bandwidth”. you can select “setting Otherwise, manually” and enter the required upload and download bandwidth with priority weighting.

Hybrid QoS  Max Throughput

Enable Application Priority and Device Priority with bandwidth limitation. Application Priority will use the DSCP value in the IP header for packet classification. [Bandwidth setting is important to QoS...click here](#)

Enable maximum performance for router with NAT acceleration and without bandwidth limitation.

To enable maximum router performance with NAT acceleration and without bandwidth limitations, please select the "**Max Throughput**" option.

# 6. Quick Setup

The Acer Wave 7 router is pre-configured as one of the three operation modes and can be re-configured in Web UI

- 1) Router Mode
- 2) Mesh Controller
- 3) Mesh Agent

1-pack router is pre-configured as Router Mode, which can be switched to support mesh network consisting multiple Acer Wave 7 routers.

2-pack and 3-pack routers are pre-configured as Mesh Controller and Agent modes to support automated mesh setup process, all you need is plugging in the power cables, inserting Internet cable in Mesh Controller, and then wait for XXX minutes to monitor the LED indicators turning from Blue to Red and then finally blinking (breathing) Blue.

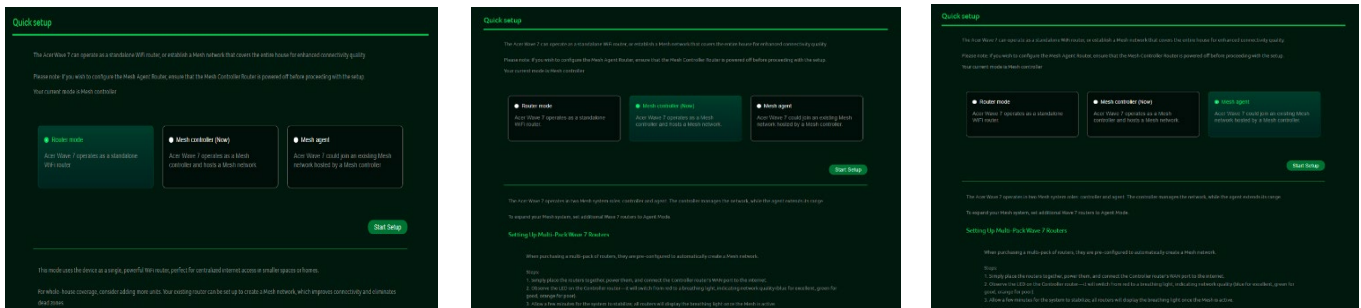

In **Router Mode(1-Pack)** or **Controller Mode(2-Pack or 3-Pack)**, connect one end of the RJ-45 cable to your DSL or cable modem and the other end to the Acer Wave 7's WAN port.

Connect your device to Acer Wave 7 via Wi-Fi or LAN cable.

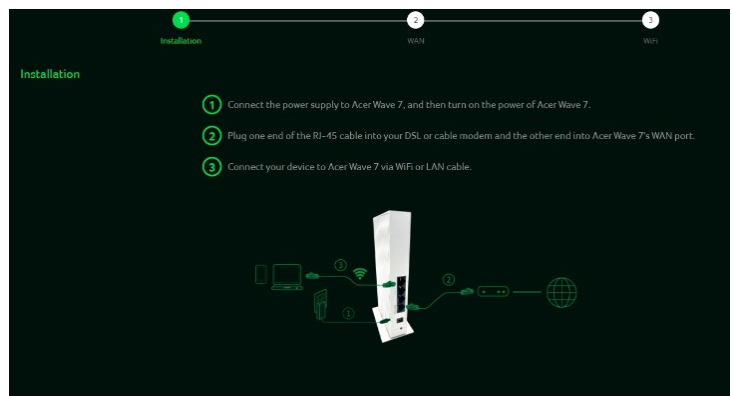

If you want to setup mesh network with routers from different pack options, the mode of some routers needs to be changed. In this page, you can see the current mode of router and switch to other modes:

### Important:

When switching the router from Agent Mode to Mesh Controller or Router Mode, you must define the SSID first

## 6.1 How to create a Mesh network with routers from two of 1-packs

To create a mesh network, set one router as the Mesh Controller Mode(A) and another router as the Agent Mode (B).

To avoid impacting performance, it is recommended not to wirelessly chain more than three layers of agents. However, you can connect multiple agents behind the controller.

Alternatively, you can use LAN cables to connect more than two agents in series.

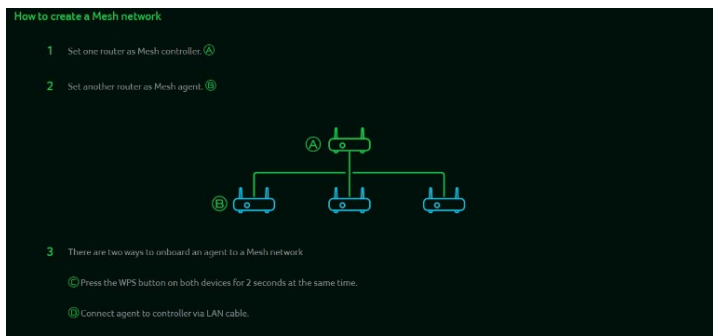

Here are the steps to create a Mesh network.

1. Go to Quick Setup and configure the main router as the Mesh Controller.
2. Power on the other Acer WAVE 7 router and set it as the Mesh Agent.
3. Place both routers close to each other.
4. There are two methods to add an agent to a Mesh network.

- I. Press the WPS button on both devices simultaneously for 2 seconds.
- II. Connect the agent to the controller using a LAN cable.

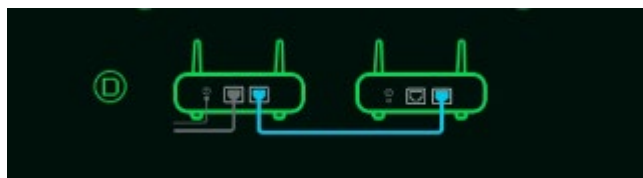
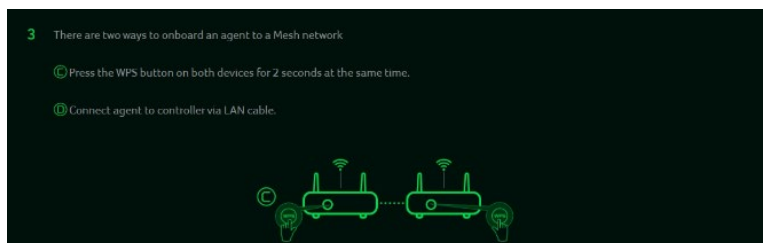

If the agent successfully connects to the controller, the LED will blink blue. If the connection fails, the LED will remain solid red.

5. Power off the agent device, relocate it, and then power it back on. Observe the LED color of the agent, which indicates the RSSI (signal strength) between the controller and the agent.

The Blue color means RSSI is good, Green color means RSSI is normal, Orange color means RSSI is poor, Red color means disconnected.

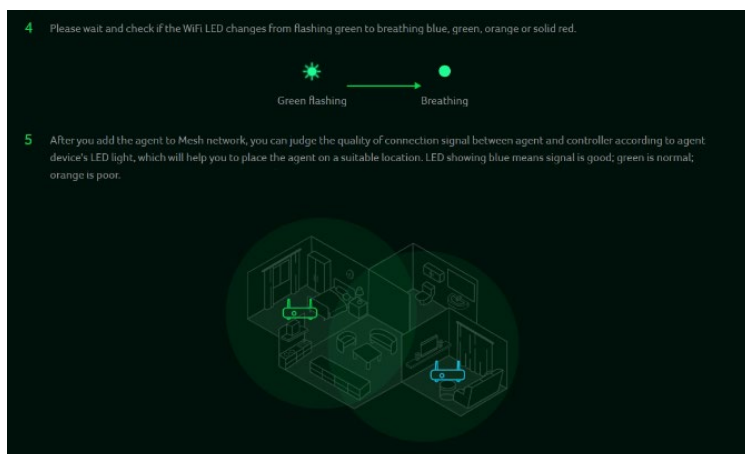

## 6.2 Mesh Topologies

Following are the mesh topologies:

- Topology – One agent
- Star topology – 2 agents

### Topology – One Agent

In one agent topology, a controller is connected with one agent, and the interface between a controller and the agent can be wireless or wired connectivity.

Blue color line indicates the good signal strength between a controller and the agent, so it is always recommended to place an agent close to the controller.

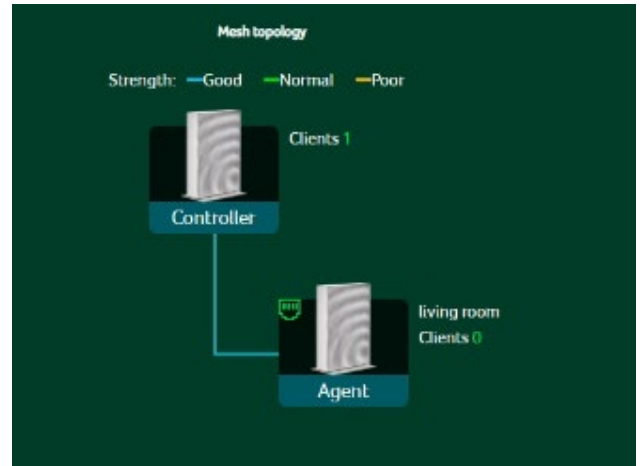

### Star topology – 2 agents

In star topology of 2 agents, a controller is simultaneously connected with three agents, and the internet between a controller and the agents can be wireless or wired connectivity.

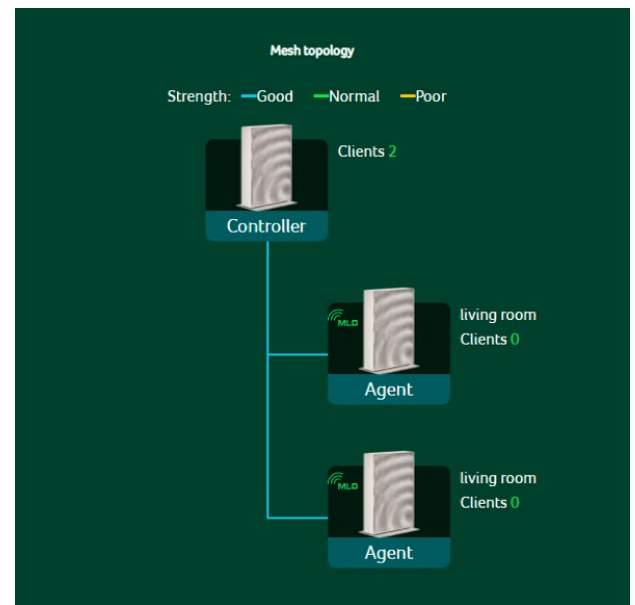

There are some limitations in our mesh which are listed below:

- I. Due to the adoption of front-haul and backhaul sharing bandwidth to connect various nodes in the Mesh network, if the Mesh agent is in a daisy-chain configuration, each layer of connected nodes needs to simultaneously handle communication with both upper-layer nodes and lower-level devices. As a result, the available bandwidth speed will be halved and evenly distributed. Based on this limitation, we recommend that users assemble the Mesh network using Ethernet cables to connect the nodes. This will avoid rate loss due to shared bandwidth (achieving lossless conditions). If users must connect the nodes wirelessly, we suggest forming a star topology network to prevent significant rate reduction caused by multi-tiered connections.
- II. Each device has a default (pre-configured) mode, such as being preset as Agent Mode. Even if the factory reset is performed, it will revert to the agent role. To switch to another role, please use the Quick Setup to make the change.
- III. Once a device is preset as an agent, you can change the role by factory reset and then accessing the Web UI (<http://192.168.76.1>). Alternatively, you can log

in using the IP address in the topology diagram to switch roles.

Note: When switching the role of an agent, make sure to power off the controller first.

IV. Mesh supports WPS Onboarding, but in cases where connection is hindered due to environmental interference, it's recommended to move the agent closer to the controller or restore the device to its factory default settings and follow the Quick Setup process to reconfigure the agent.

Alternatively, you can perform the setup steps via Ethernet connection.

V. If the Mesh Wi-Fi SSID or password is changed in an existing Mesh network, agents will apply the new configuration after the synchronization process is done. If the agent does not apply the new configuration successfully or the agent is in the offline status, it must go through the onboarding process with the controller again. This is necessary for the updated SSID or password to be applied to these agents.

## 7. WAN

### 7.1 WAN Status

This tab provides details about WAN connectivity status and the following key information::

- Time duration (format HH:MM:SS)
- MAC address
- Connection Mode: DHCP, static IP, PPPoE, etc.
- IP address
- Subnet mask
- Default gateway
- Primary & Secondary DNS server

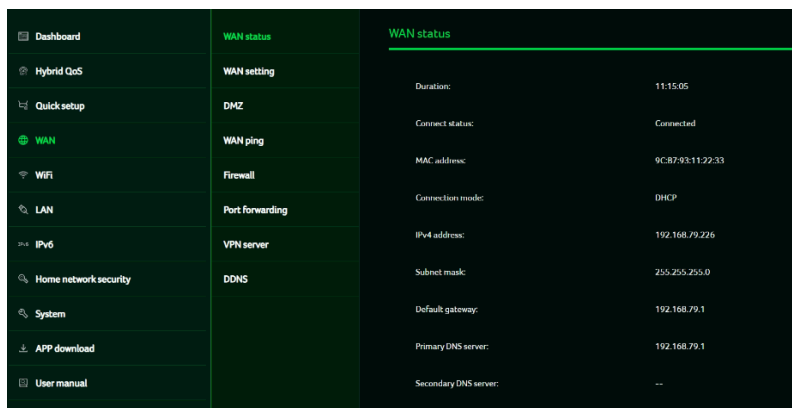

### 7.2 WAN Setting:

On this page, you can configure the Ethernet WAN connection mode to DHCP, Static IP, or PPPoE, or switch the WAN port to LAN1 based on your connection needs. Click the dropdown arrow to reveal and select your preferred WAN settings.

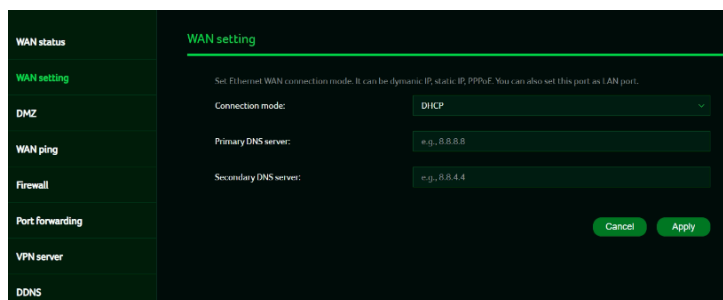

You can select “Switch WAN port to LAN1” if you are using the router in repeater mode, where the WAN port is not needed. This will provide you with an additional LAN port.

### 7.3 DMZ

A DMZ (Demilitarized Zone) is a physical or logical subnetwork that exposes an organization’s public-facing services to an untrusted, typically larger network such as the Internet.

If external users are unable to access specific network services provided by the Local Area Network (LAN), use the DMZ function to designate the client offering these services as the DMZ host. Enter the host’s IP address, and external users will then have access to all the services provided by that host.

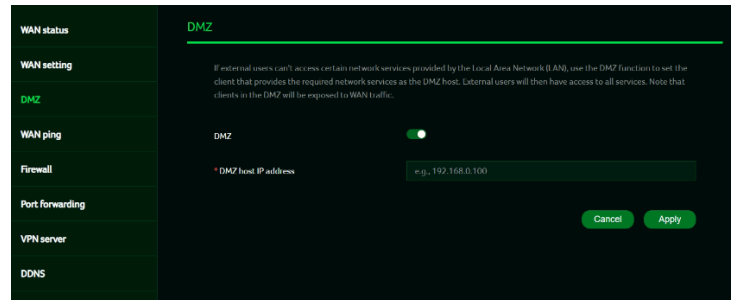

### 7.4 WAN Ping

Enabling this feature allows the WAN port of the Acer Wave 7 to respond to ping requests sent to the WAN IP address from the Internet.

For enhanced security, keep this feature turned OFF to prevent the device from responding to WAN pings.

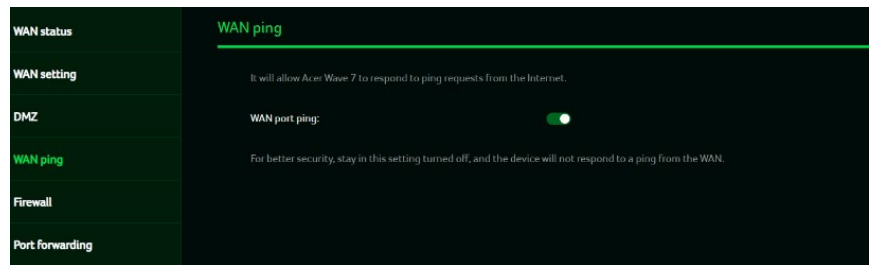

### 7.5 Firewall

Set up a firewall rule to either accept or block network requests from the Internet. To configure a firewall rule, click the (+) icon and enter the name, source and destination ports and IP addresses, protocol, target, and status information.

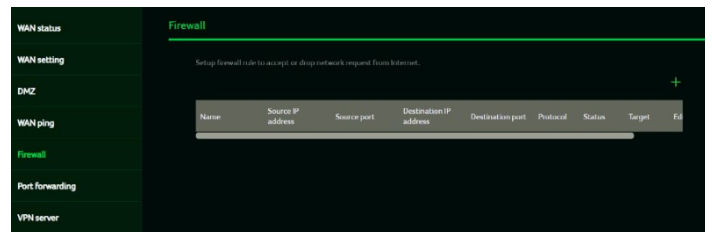

### 7.6 Port Forwarding

This feature enables external users to connect to Local Area Network (LAN) services using protocols such as Hypertext Transfer Protocol (HTTP), File Transfer Protocol (FTP), and others. To add an application, click the (+) icon and select the desired service.

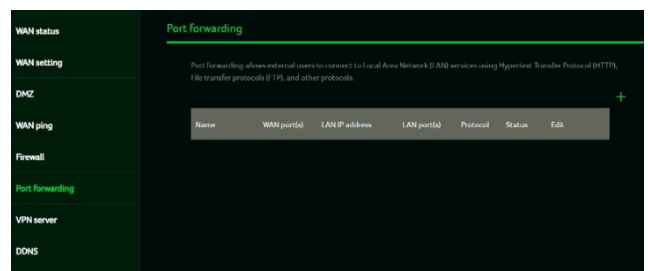

You can choose a service profile from the Common Services tab, and it will automatically display its name, port number, and protocol.

Enter the LAN IP address, select the status as ON or OFF, and click the “Apply” button to activate the service.

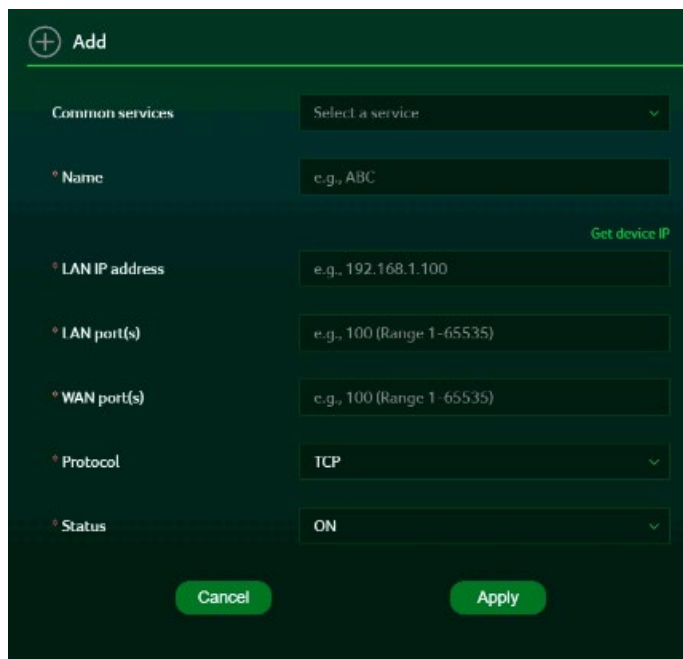

The screenshot shows a configuration form titled "Add". It includes the following fields and options:

- Common services:** A dropdown menu with the text "Select a service".
- Name:** A text input field with the placeholder "e.g., ABC".
- LAN IP address:** A text input field with the placeholder "e.g., 192.168.1.100". A "Get device IP" link is visible to the right.
- LAN port(s):** A text input field with the placeholder "e.g., 100 (Range 1-65535)".
- WAN port(s):** A text input field with the placeholder "e.g., 100 (Range 1-65535)".
- Protocol:** A dropdown menu with "TCP" selected.
- Status:** A dropdown menu with "ON" selected.

At the bottom of the form are two buttons: "Cancel" and "Apply".

## 7.7 VPN Server

Setup VPN server on Acer Wave 7 for remote VPN connection over the Internet. This router offers following VPN service:

### 7.7.1 OpenVPN

Before enabling the VPN server, you need to generate a certificate. Once the VPN server is set up, the VPN connection will be established, and its status will be displayed. This includes the connection type, remote and local IP addresses, and the connection duration.

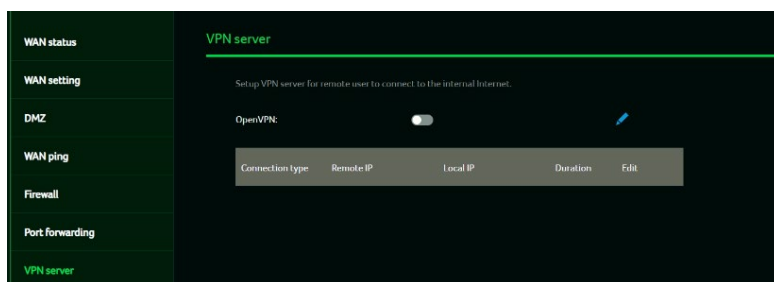

The screenshot shows the "VPN server" configuration page. It includes the following elements:

- Left sidebar:** A list of navigation options: WAN status, WAN setting, DMZ, WAN ping, Firewall, Port forwarding, and VPN server (highlighted).
- Main content area:**
  - VPN server:** A section header.
  - Setup VPN server for remote user to connect to the internal Internet.** A sub-header.
  - OpenVPN:** A toggle switch that is currently turned off.
  - Table:** A table with the following columns: Connection type, Remote IP, Local IP, Duration, and Edit.

**OpenVPN** is an SSL VPN that uses a selected UDP or TCP port, providing flexible configuration options. User access includes two options: Home Network and Internet, as well as Home Network only. Additionally, users can export the OpenVPN configuration file (client.ovpn).

Enter the following information to configure Open VPN services.

- 1) WAN IP address
- 2) Service port
- 3) VPN subnet
- 4) VPN netmask

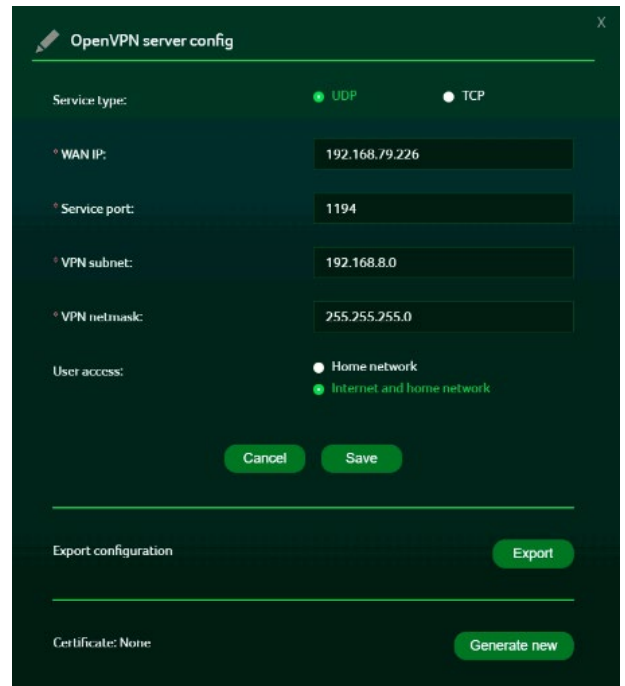

### 7.8 DDNS

A DDNS service assigns a fixed domain name to your router's dynamic IP address. You need to register with one of the following DDNS providers:

1. Dyn.com
2. No-IP
3. Google Domains
4. Cloudflare.com

After selecting your DDNS provider, enter the hostname, username, and password, then click the 'Apply' button to activate DDNS.

The DDNS and WAN status will be displayed once the DDNS information is entered.

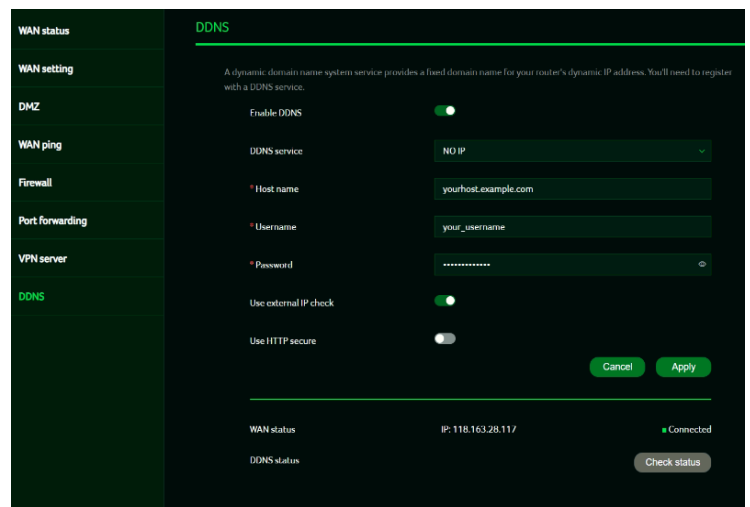

# 8. Wi-Fi

## 8.1 Wi-Fi Status

Displays key information such as:

- Wi-Fi SSID
- SSID Broadcast
- Security
- Channel
- Connected devices
- Gateway address
- Mac address of 2.4GHz, 5GHz & 6GHz bands

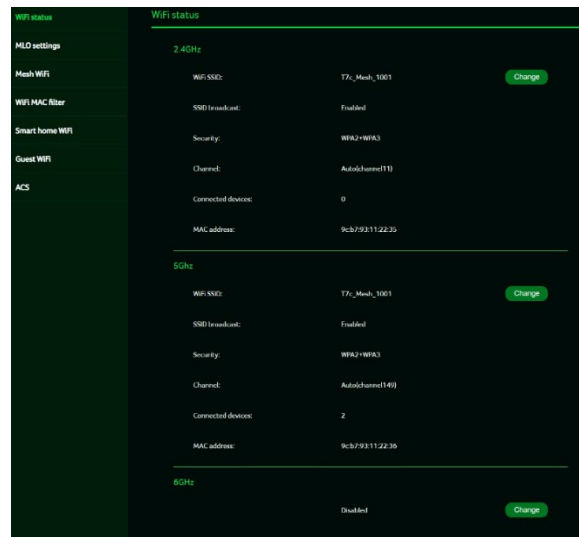

## 8.2 MLO Settings

Wi-Fi 7's MLO (Multi-Link Operation) is a significant technological breakthrough. It allows devices to simultaneously transmit and receive data across various frequency bands and channels. This capability enables the new standard to achieve and maintain 1ms latency, even for the most data-intensive real-time applications.

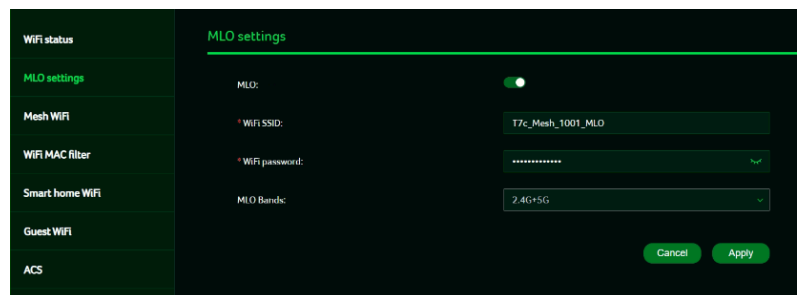

Connecting to an MLO network enhances throughput and improves network efficiency. When the mesh network is activated, the backhaul settings between the controller and the agent default to MLO's 5G and 6G bands.

## 8.3 Mesh Wi-Fi (In Mesh Mode)

This tab displays information about the Mesh Wi-Fi SSID and password.

Band steering is enabled by default, automatically connecting your devices to the optimal Wi-Fi frequency in your environment.

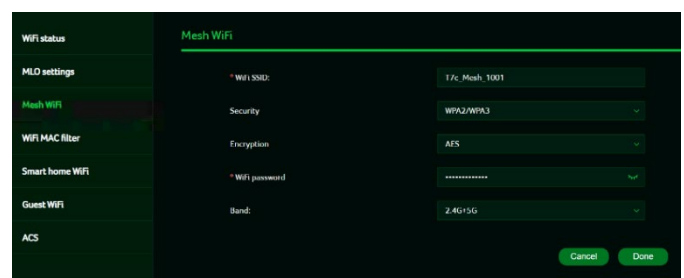

### 8.4 Wi-Fi MAC Filter

Devices added to the Wi-Fi MAC filter will be blocked from accessing the Internet.

To add a device to the filter table, click the (+) icon and enter the device's name and MAC address. You can add up to 32 devices to the MAC filter.

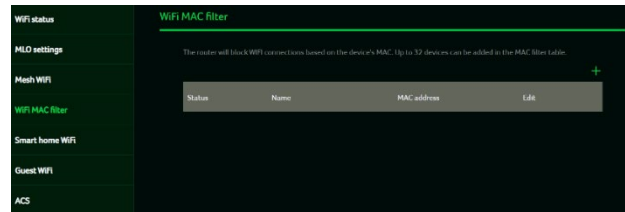

### 8.5 Smart home Wi-Fi

You can enable / disable smart home Wi-Fi on this tab. It will provide the internet connection for the devices, however no connection will be provided to the other devices.

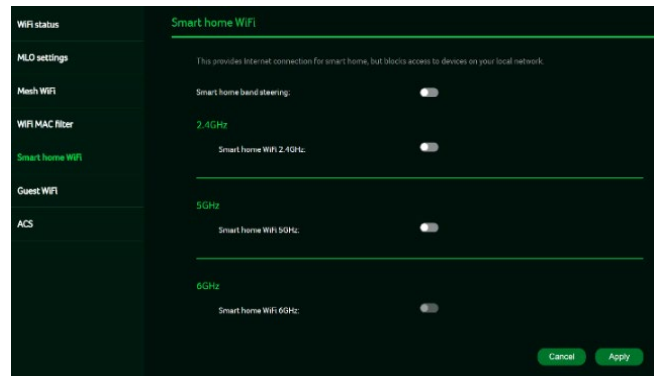

### 8.6 Guest Wi-Fi

This tab provides information about the Internet connection for guests and their devices accessing your network.

Guest Wi-Fi password is set by the default for all bands, so it is suggested changing the passwords for security reasons.

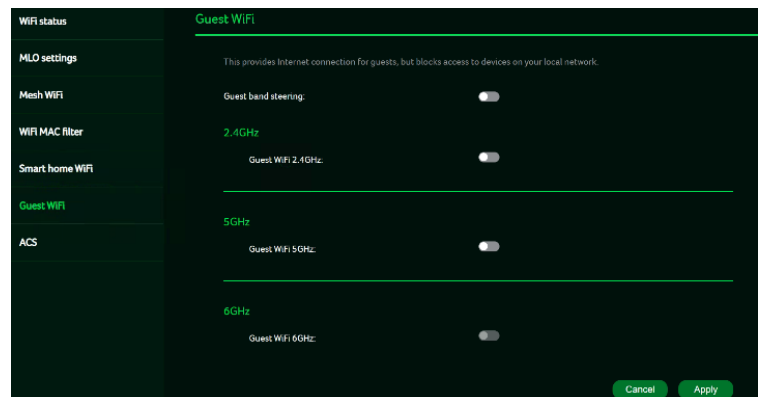

### 8.7 ACS (Automatic Channel Selection)

ACS is a mechanism to optimize the channel assignment. It selects the best working channel dynamically. One that is clear and has the least traffic.

Note 1: There will be a small delay, rescanning, and then cycling OFF and ON if the client is associated with the ACS enablement band. Please check your device's wireless connection and select the best Wi-Fi T7c router SSID after the ACS process is completed.

Note 2: The ACS is not applicable if all three bands (2.4GHz, 5GHz, and 6GHz) are configured as fixed channels. ACS also works in a Mesh mode and when the device is in mesh mode, this will trigger channel planning.

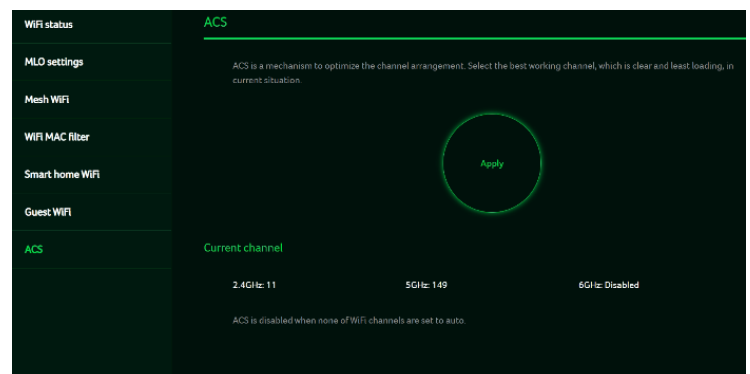

# 9. LAN

## LAN status

On this page, you can view the status of each LAN port, including its associated IP address, MAC address, and DHCP server. The Acer Wave 7 features one Game port and two LAN ports, with one of the LAN ports also serving as a WAN port.

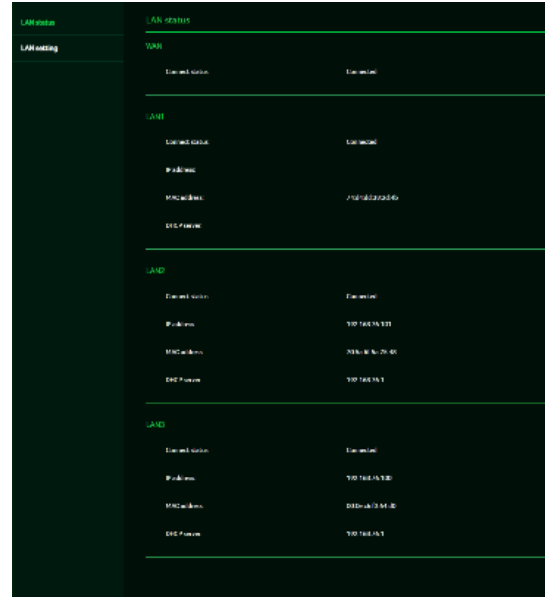

## LAN Setting

This tab allows you to configure the LAN IP gateway address and toggle the DHCP server feature on or off. You can enter the gateway address and subnet mask. The DHCP server assigns IP addresses, default gateways, and other network parameters to client devices and can be enabled or disabled based on your network needs.

The following subnets are reserved for default services and should not be used as gateway addresses:

1. 192.168.7.x (IPsec VPN)
2. 192.168.8.x (OpenVPN)
3. 192.168.10.x (Guest Wi-Fi)

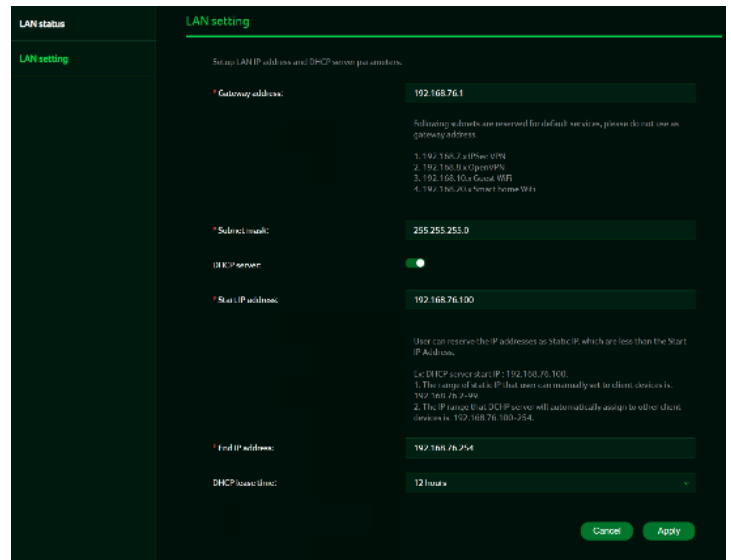

# 10. IPv6

You can configure IPv6 settings from this tab. The Acer Wave 7 supports the following IPv6 modes: DHCPv6, static IPv6, PPPoE, 464xlat, 6rd, and DS-Lite. By default, these connection modes are disabled.

Please consult your local Internet Service Provider before enabling and configuring these options.

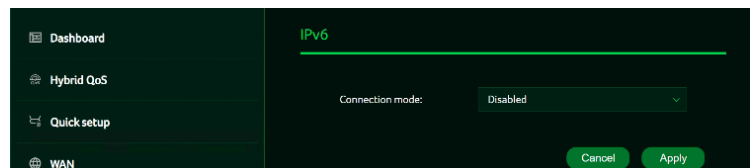

# 11. Home Network Security

The Home Network Security tab includes network security settings as well as web and app controls within the parental control feature. Both of these features require acceptance of the Trend Micro license agreement before they can be enabled.

## 11.1 Network Security Setting

\*/This tab contains the network security-related information, powered by Trend Micro, where you can turn on/off the security engine and enable protection against malicious sites, network attacks and harmful connections coming from IoT devices.

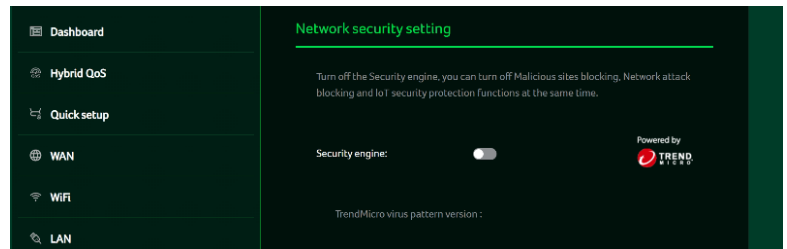

## Malicious site blocking

prevents unwanted sites from opening, thereby protecting your computer from Trojan infections. The "Trend Micro Web Reputation Service (WRS)" feature identifies malicious URLs and allows you to take action against them.

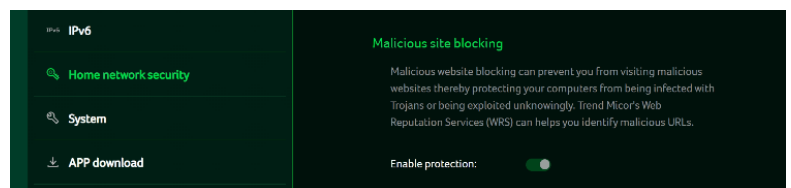

By enabling **Network attack blocking** feature, the router detects the infected devices and block its network behavior to prevent infection in other devices.

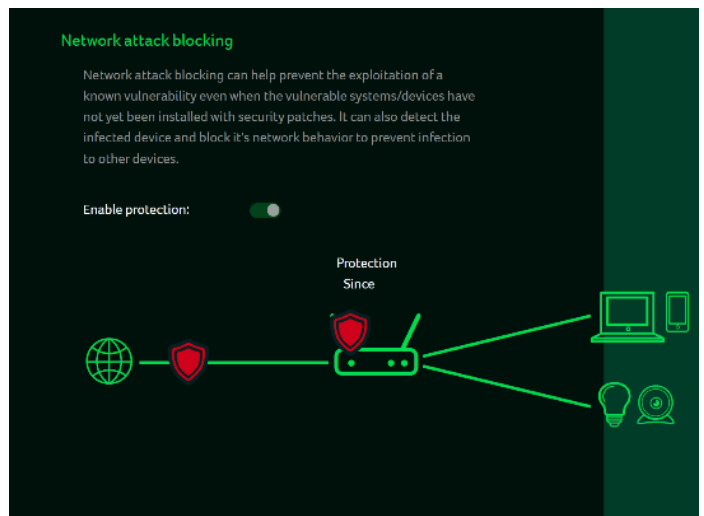

Enabling the IoT security protection feature detects and blocks harmful connections from compromised IoT devices using Trend Micro's smart protection network.

This feature utilizes a continuously updated IoT device reputation database to prevent false connections and ensure network security.

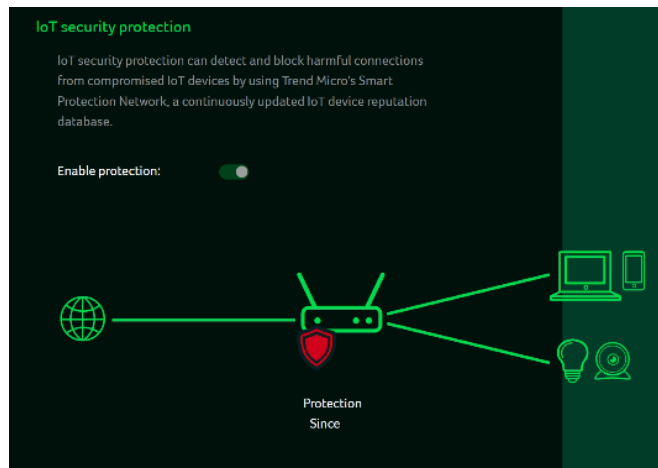

## 11.2 Parental Control

This feature allows you to control and block unwanted sites on specific devices.

You can enable/disable URL controller.

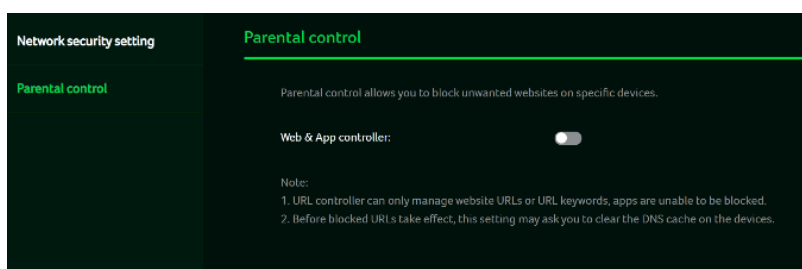

Clicking the (+) icon will open a window where you can enter details for the device list, including the device name, MAC address, URL, status, and Internet access time limits.

Note: If the end time is earlier than the start time, the block period will extend to the next day. If the start time is the same as the end time, the block will apply for the entire day.

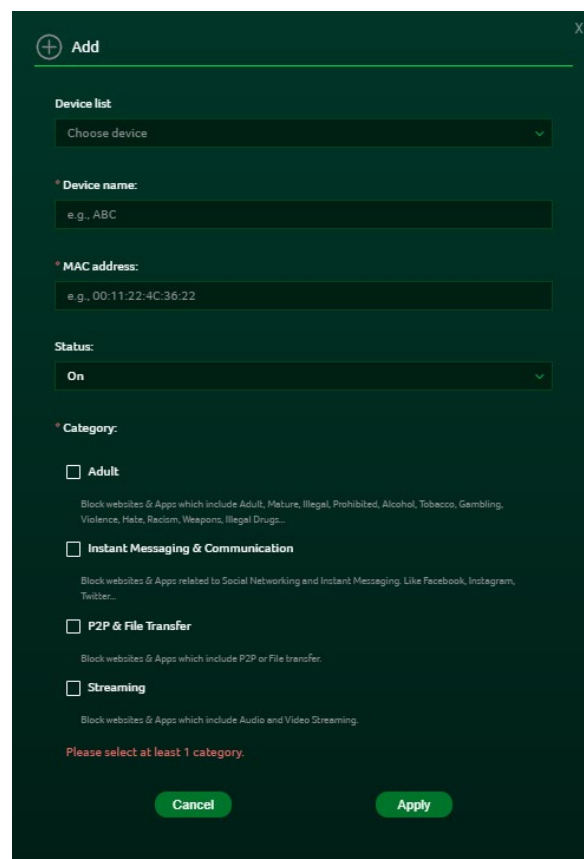

# 12. SYSTEM

## 12.1 Operation Mode

In this tab, you can view the different operation modes of the router. This is basically same view as we have in the quick setup, as we can set the operation mode from here.

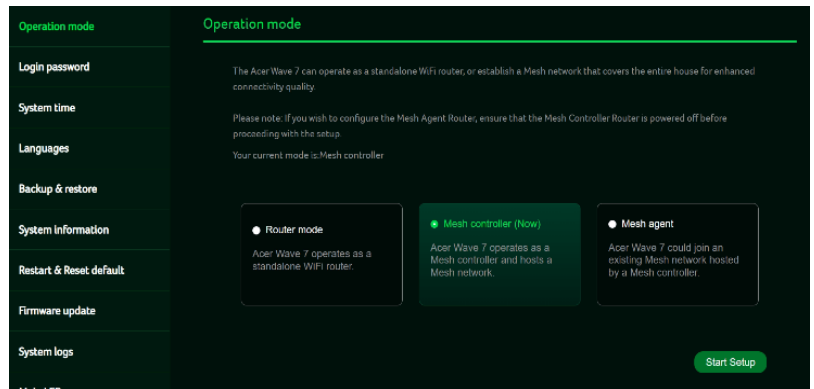

## 12.2 Login Password

You can change the password of your Acer WAVE 7 from this page.

To make a new password, you need to enter your current password first. Please use a strong password to keep it secure.

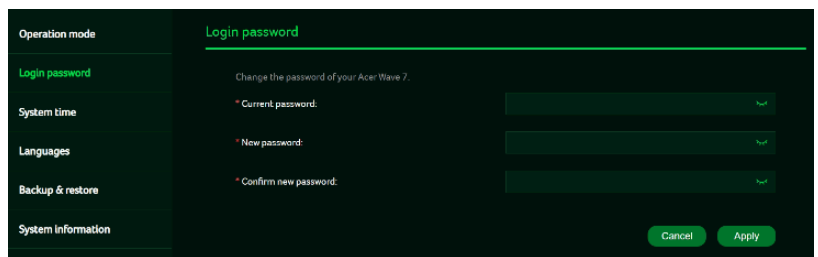

## 12.3 System Time

This tab allows you to synchronize the device time with the system time by enabling “Automatically set time zone”.

By enabling “daylight savings time”, the device will automatically adjust the time according to the time zone.

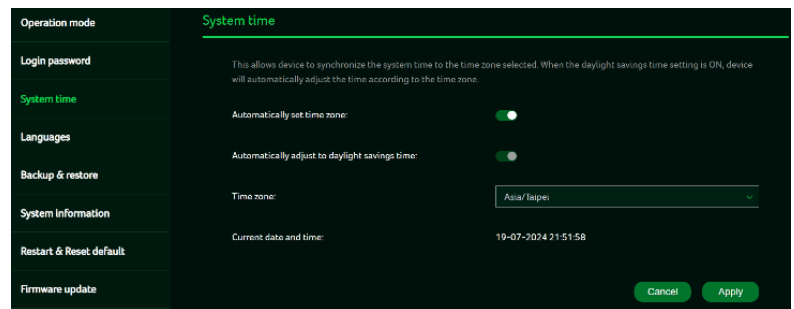

## 2.4 Languages

You can select the language of your Acer Wave 7 from this tab.

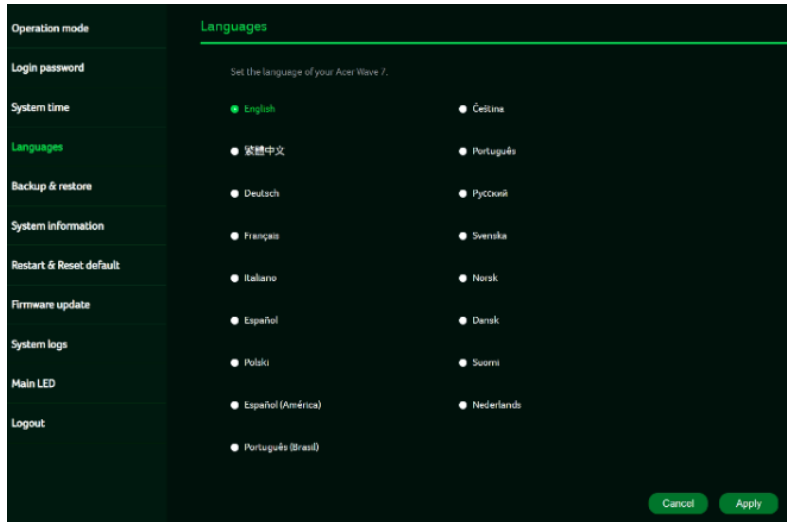

## 12.5 Backup and Restore

In this tab, you can check how to save the configuration: Click on "Backup" to backup current device configuration. On both Windows and MAC OS, this is saved to your 'Downloads' folder.

How to restore the configuration:

- 1) Click Browse to select a file
- 2) Click Restore

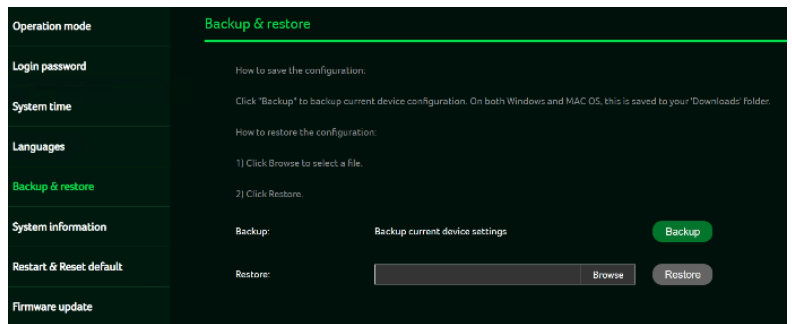

## 12.6 System Information

It shows key device information of Acer Wave 7, such as:

- Device name
- Serial number
- Firmware version
- Web version

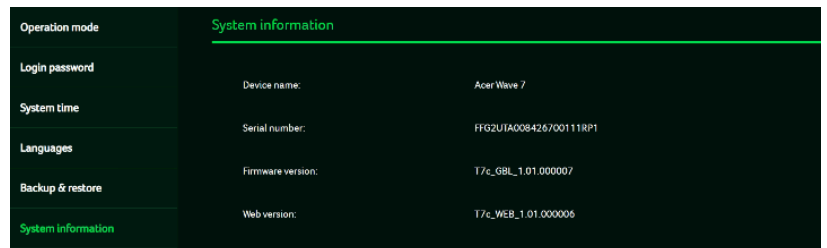

## 12.7 Restart and Reset Default

From this tab, you can click on "Restart device" to reboot the router and click on "Factory data reset" to restore the factory default settings.

Please check if you bind your device with Predator Connect Mobile App.

After the factory reset, please don't forget to unbind the device from the mobile app.

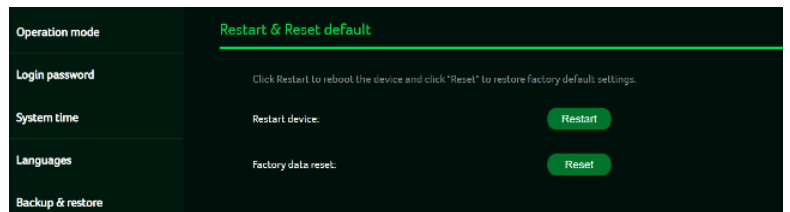

## 12.8 Firmware Update

In this tab, you can check the existing firmware version and also, click on “check new”, to see if there is an update available.

You may click on the top right icon “New firmware available” to upgrade the Acer WAVE 7 with the latest firmware.

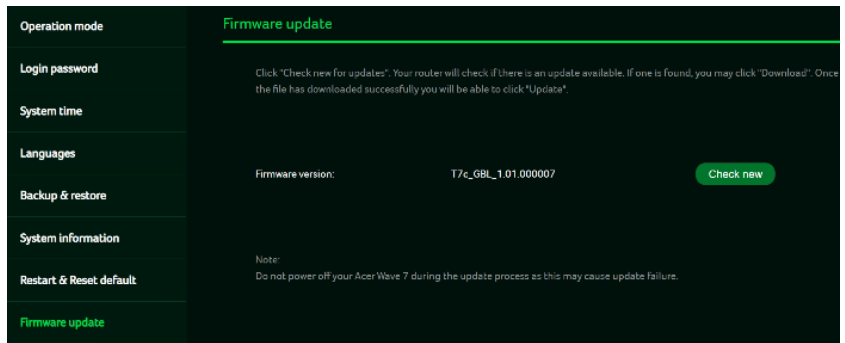

## 12.9 System Log

The System logs consists of general logs and Wi-Fi logs. It will display here all the recent 100 activities you have done with the router.

You can save the system logs by clicking the “Save log” button at the bottom of the page. The main purpose of savings logs is to allow the logs to be saved and sent back to Acer for analysis, if there are issues encountered.

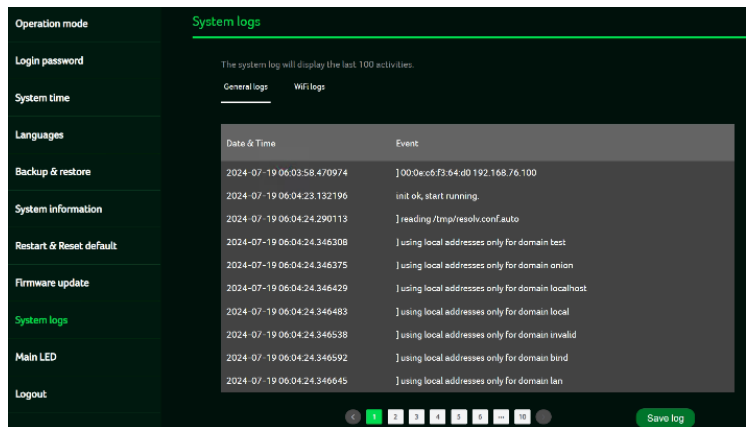

## 12.10 Main LED

This tab displays information about LED colors and its indication. These LED indicators will help you to know and understand router behavior.



# 13. APP Download

User can download the mobile App by scanning the QR code, available in “App download” tab, to control the following features:

1. Quick setup assistance
2. Control the router remotely
3. Get notifications of:
  - 1) Router Internet disconnection
  - 2) USB storage removal

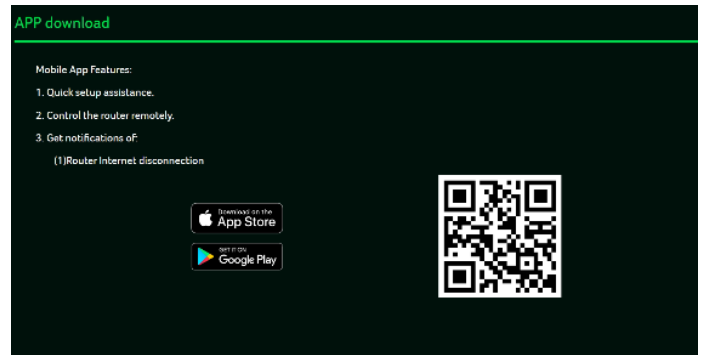

# 14. Troubleshooting

## 14.1 Quick Tips

This section outlines common issues you may encounter and provides a sequence to restart your device and network:

1. Turn off the modem and unplug the power cord.
2. Plug the power cord back in and turn on the modem. Wait two minutes for the modem's LED to become steady.
3. Wait for the device's upper deck main LED to show a steady breathing pattern.

## 14.2 Frequently Asked Questions (FAQs)

### 14.2.1 What can I do if I forget my wireless password?

- Connect to the T7c router via Ethernet cable LAN.
- Visit device portal <http://acer-connect.com> and login admin.
- Go to Wi-Fi -> Basic settings/Retrieve or reset the Wi-Fi passwords.

### 14.2.2 What can I do if I forget the router's web portal admin password?

Reset the device by pressing and holding the reset button until the LED starts blinking white. Once the device restores to factory settings, log in to the web admin portal using the admin password found on the label at the bottom of the device.

Note 1: The web admin will be locked after five incorrect password attempts. To unlock it, reboot the device.

Note 2: After resetting, set up the device's internet connection and change the admin password.

Note 3: If you have bound the device using the Predator Connect mobile app, remember to unbind it after the factory reset.

### 14.2.3 What can I do if I can't log into the router's web admin portal?

Please follow the steps below to check on your client's device.

- Check whether the client-allocated IP and DNS server IPs both are with the same subnet and gateway.
- Clean the browser cookies or use private/Incognito mode to access the router admin.

### 14.2.4 What can I do if I can't surf the internet even though the configuration is finished?

Please follow the step below to check on your T7c router:

- Login to the web admin portal dashboard to check Internet status.
- Continuingly, if the Internet status is up and connect. Go to the WAN setting, manually configure the DNS server using the below IP and apply:  
Primary DNS server: 8.8.8.8  
Secondary DNS server: 8.8.4.4
- If the issue is still there, please restart the modem and router accordingly.

# 15.Factory Default Settings

Router web admin	
URL	http://acer-connect.com or http://192.168.76.1
Login Password (case-sensitive)	XXXXXXXX (XXXX is randomized variables. Please check the device's bottom label)
Local Network (LAN)	
Gateway address	192.168.76.1
Subnet mask	255.255.255.0
DHCP server	192.168.76.1
DHCP range	192.168.76.100 to 192.168.76.254
Time zone	Depends on the country or region you bought the router.
DHCP starting IP address	192.168.76.100
DHCP ending IP address	192.168.76.254
Time adjusted for daylight save time	Enabled.
Wireless LAN (WLAN)	
Wi-Fi SSID (case-sensitive)	2.4GHz: T7c_YYYY_2.4GHz (Router Mode) 5GHz: T7c_YYYY_5GHz (Router Mode) 6GHz: T7c_YYYY_6GHz (Router Mode)  2.4GHz +5GHz or 6GHz: T7c_YYYY (Controller Mode) (YYYY is randomized variables. Please check the device's bottom label)
Security	2.4GHz : WPA2/WPA3 5GHz : WPA2/WPA3 6GHz : WPA3
SSID Broadcast	Enabled.
RF channel	2.4GHz : Auto 5GHz : Auto 6GHz : Auto
Default operation mode (with AX enabled)	2.4GHz: 2x2 MIMO streams, 40MHz, 573MBps 5GHz: 2x2 MIMO streams, 160MHz, 4324Mbps or 6GHz: 2x2 MIMO streams, 320MHz, 5764Mbps
Guest Wi-Fi	Disabled.
Home Network Security	Disabled.

# 16. Router basic Specification

<b>Processor</b>	Qualcomm Immersive Home 326	
<b>Memory</b>	RAM	512MB
	Storage	512MBMB
<b>Wireless LAN</b>	IEEE standard	802.11 a/b/g/n/ac/ax/be
	MU-MIMO	2x2 MIMO
	Band	Dual band, 2.4+ 5GHz or 2.4+6GHz
	Throughput	BE6400
<b>Ethernet</b>	WAN	1 x 2.5Gbps
	LAN	3 x 1Gbps
<b>Button Key</b>	WPS	Yes, WPS and Mesh pairing
	Reset	Yes, Factory reset
<b>LED</b>	LED	LED *1
<b>Form factor</b>	Dimension	95mmx 57mm x188.8mm with stand
	Weight	350g
<b>DC Power Jack</b>	Input Voltage	AC 100-240V, 50-60Hz,
	Power Adapter	12V/1.5A

# 17. Regulatory Information

## 17.1 Important Safety Precaution

Your Acer WAVE 7 is manufactured to comply with European safety standards. This section outlines the safety precautions for using the device. Please read the safety and operation instructions before using your device and accessories and keep these instructions for future reference.

## 17.2 Condition of Use

- The device is not water-resistant. Please protect the device from water or moisture and do not touch the device with wet hands. Otherwise short-circuit and malfunction of the product or electric shock may occur.
- Keep the device and accessories in a cool, well-ventilated area and away from direct sunlight. Do not place the device in a container with poor heat dissipation. Do not enclose or cover your device with clothes, towels, or other objects.
- Put your device in places beyond the reach of children. Do not allow children to use the wireless device without guidance.
- Do not use your device at places for medical treatment (in an operating room, intensive care unit, or coronary care unit, etc.) where wireless device use is prohibited.
- To reduce the risk of accidents, do not use your device while driving.
- RF signals may affect the electronic systems of motor vehicles. For more information, consult the vehicle manufacturer.
- EE recommends using the charger supplied with your device. Use of another type of charger may result in malfunction and/or danger.

## 17.3 Cleaning and Maintenance

- Do not attempt to dry your device with an external heat source, such as a microwave oven or hair dryer.
- Use a clean, soft, and dry cloth to clean the device and accessories.

## 17.4 Disposal Instructions

Do not throw this electronic device into the trash when discarding. To minimize pollution and ensure utmost protection of the global environment, please recycle. For more information on the Waste from Electrical and

Electronics Equipment (WEEE) regulations,

visit [www.acer-group.com/public/Sustainability](http://www.acer-group.com/public/Sustainability)



## 17.5 Ethernet Cable Line Safety

- Disconnect all Ethernet cable lines from the equipment when not in use and/or before servicing.
- To avoid the remote risk of electric shock from lightning, do not connect the Ethernet cable line to this equipment during lightning or thunderstorms.

## 17.6 Medical Devices

The operation of radio transmitting equipment, including wireless phones, may interfere with inadequately protected medical devices. Consult a physician or the manufacturer of the medical device to determine if it is adequately shielded from external RF energy or if you have any questions. Turn off your device in health care facilities when regulations instruct you to do so, as hospitals or health care facilities may have equipment sensitive to external RF transmissions.

**Pacemakers.** Pacemaker manufacturers recommend that a minimum separation of 15.3 centimeters (6 inches) be maintained between wireless devices and a pacemaker to avoid potential interference with the pacemaker. These recommendations are consistent with the independent research by and recommendations of Wireless Technology Research. Persons with pacemakers should do the following:

- Always keep the device more than 15.3 centimeters (6 inches) from the pacemaker
- Not carry the device near you pacemaker when the device is switched on. If you suspect interference, switch off your device, and move it.

**Hearing aids.** Some digital wireless devices may interfere with some hearing aids. If interference occurs, consult your service provider.

## 17.7 Vehicles

RF signals can affect improperly installed or inadequately shielded electronic systems in motor vehicles, such as electronic fuel injection, anti-lock braking, electronic speed control, and airbag systems. For more information, consult the manufacturer or representative of your vehicle or any added equipment. Only qualified personnel should service or install the device in a vehicle. Faulty installation or service can be dangerous and may invalidate the device's warranty. Regularly check that all wireless equipment in your vehicle is properly mounted and functioning. Do not store or carry flammable liquids, gases, or explosive materials in the same compartment as the device, its parts, or accessories. For vehicles equipped with airbags, remember that airbags inflate with great force. Do not place objects, including installed or portable wireless equipment, over the airbag or in the airbag deployment area. Improper installation of in-vehicle wireless equipment can cause serious injury if the airbag inflates. Using your device while flying in an aircraft is prohibited. Turn off your device before boarding, as the use of wireless devices in an aircraft may be dangerous to its operation, disrupt the wireless network, and may be illegal.

## 17.8 Warning

- Do not attempt to open the device by yourself. Disassembling may result in damage to the device. Small parts may also present a choking hazard.
- When this device is switched on, it should be kept at least 15 cm from any medical device

such as a pacemaker, a hearing aid or insulin pump, etc.

- Switch this device off when you are near gas or flammable liquids. Strictly obey all signs and instructions posted in any potentially explosive atmosphere.

## 17.9 Explosive Device Proximity Warning

Turn off your device in any area with a potentially explosive atmosphere and follow all posted signs and instructions. These areas include places where you would normally be advised to turn off your vehicle engine, as sparks could cause an explosion or fire, leading to injury or death. Turn off the device at refueling points, such as near gas pumps at service stations, and adhere to restrictions on the use of radio equipment in fuel depots, storage and distribution areas, chemical plants, or areas with blasting operations. Potentially explosive atmospheres are often, but not always, clearly marked. They include locations such as below deck on boats, chemical transfer or storage facilities, vehicles using liquefied petroleum gas (e.g., propane or butane), and areas where the air contains chemicals or particles such as grain, dust, or metal powders. Do not use your device when wireless phone use is prohibited or when it may cause interference or danger.

- Warning: Do not operate a portable transmitter (including this wireless adapter device) near unshielded blasting caps or in an explosive environment unless the transmitter has been modified to be qualified for such use.
- Warning: The wireless adapter is not designed for use with high-gain directional antennas

## 17.10 Wireless adapter regulatory information

- Warning: For safety reasons, turn off all wireless or radio transmitting devices when using your device under the following conditions.

Always follow any special regulations in force in any area, and switch off your device when its use is prohibited or when it may cause interference or danger. Use the device only in its normal operating positions. This device meets RF exposure guidelines when used as intended. To successfully transmit data files or messages, a good quality connection to the network is required. Sometimes, data transmission may be delayed until such a connection is available. Note that parts of the device are magnetic. Metallic materials may be attracted to it, and individuals with hearing aids should avoid holding the device close to their ear with the hearing aid. Keep credit cards or other magnetic storage media away from the device, as the information stored on them may be erased.

### **Aircraft**

Warning: FCC and FAA regulations may prohibit the use of radio-frequency wireless devices (wireless adapters) during flight, as their signals could interfere with critical aircraft instruments. Always consult airport staff and cabin crew before activating your device's wireless adapter while on board.

## The wireless adapter and your health

The wireless adapter, like other radio devices, emits radio frequency electromagnetic energy. However, the energy emitted by the wireless adapter is less than that emitted by other wireless devices, such as mobile phones. The wireless adapter operates within the guidelines established by radio frequency safety standards and recommendations. These standards are based on the consensus of the scientific community, formed through deliberations of panels and committees of scientists who continuously review and interpret extensive research literature. In certain situations or environments, the use of the wireless adapter may be restricted by the proprietor of the building

or responsible representatives of the applicable organization. Examples of such situations may include:

- Using the wireless adapter on board airplanes, or
- Using the wireless adapter in any other environment where the risk of interference with other devices or services is perceived or identified as being harmful.

If you are unsure about the policy regarding the use of wireless adapters in a specific location or organization (such as an airport), it is recommended to seek authorization before activating the adapter.

### **17.11 Statement**

[USA]

- FCC regulations restrict the operation of this device to indoor use only.
  - The operation of this device is prohibited on oil platforms, cars, trains, boats, and aircraft, except that operation of this device is permitted in large aircraft while flying above 10,000 feet.
  - Operation of transmitters in the 5.925–7.125 GHz band is prohibited for control of or communications with unmanned aircraft systems.
- 
- This device complies with part 15 of the FCC Rules. Operation is subject to the following two conditions:  
(1) This device may not cause harmful interference, and  
(2) this device must accept any interference received, including interference that may cause undesired operation.

NOTE: This equipment has been tested and found to comply with the limits for a Class B digital device, pursuant to part 15 of the FCC Rules. These limits are designed to provide reasonable protection against harmful interference in a residential installation.

This equipment generates, uses and can radiate radio frequency energy and, if not installed and used in accordance with the instructions, may cause harmful interference to radio communications. However, there is no guarantee that interference will not occur in a particular installation.

If this equipment does cause harmful interference to radio or television reception, which can be determined by turning the equipment off and on, the user is encouraged to try to correct the interference by one or more of the following measures:

- Reorient or relocate the receiving antenna.
- Increase the separation between the equipment and receiver.
- Connect the equipment into an outlet on a circuit different from that to which the receiver is connected.
- Consult the dealer or an experienced radio/TV technician for help.

Changes or modifications not expressly approved by the party responsible for compliance could void the user's authority to operate the equipment.

- This equipment complies with FCC radiation exposure limits set forth for an uncontrolled environment. This equipment should be installed and operated with a minimum distance of 20 cm between the radiator and a human body.

### **[Canada — Industry Canada (IC) ]**

This device complies with RSS247 of Industry Canada.

- This device contains licence-exempt transmitter(s) that comply with Innovation, Science and Economic Development Canada's licence-exempt RSS(s). Operation is subject to the following two conditions:  
(1) this device may not cause interference,  
(2) this device must accept any interference, including interference that may cause undesired operation of the device.
- 
- L'émetteur exempt de licence contenu dans le présent appareil est conforme aux CNR d'Innovation, Sciences et Développement économique Canada applicables aux appareils radio exempts de licence. L'exploitation est autorisée aux deux conditions suivantes :

(1) L'appareil ne doit pas produire de brouillage;

(2) L'appareil doit accepter tout brouillage radioélectrique subi, même si le brouillage est susceptible d'en compromettre le fonctionnement.

- This equipment complies with ISED radiation exposure limits set forth for an uncontrolled environment. This equipment should be installed and operated with a minimum distance of 20 cm between the radiator and a human body.
- Cet équipement est conforme aux limites d'exposition aux rayonnements ISED établies pour un environnement non contrôlé. Cet équipement doit être installé et utilisé avec une distance minimale de 20 cm entre le radiateur et un corps humain.

## [NCC]

取得審驗證明之低功率射頻器材，非經核准，公司、商號或使用者均不得擅自變更頻率、加大功率或變更原設計之特性及功能。低功率射頻器材之使用不得影響飛航安全及干擾合法通信；經發現有干擾現象時，應立即停用，並改善至無干擾時方得繼續使用。前述合法通信，指依電信管理法規定作業之無線電通信。低功率射頻器材須忍受合法通信或工業、科學及醫療用電波輻射性電機設備之干擾。

應避免影響附近雷達系統之操作。

高增益指向性天線只得應用於固定式點對點系統。

## 17.12 EU Regulatory Conformance

### *List of applicable countries*

This product must be used in strict accordance with the regulations and constraints in the country of use. For further information, contact the local office in the country of use. Please see [https://europa.eu/european-union/about-eu/countries\\_en](https://europa.eu/european-union/about-eu/countries_en) for the latest country list.

### *Specific absorption rate information*

This device meets the EU requirements on the limitation of exposure of the general public to electromagnetic fields by way of health protection. The limits are part of extensive recommendations for the protection of the general public. These recommendations have been developed and checked by independent scientific organizations through regular and thorough evaluations of scientific studies. The unit of measurement for the European Council's recommended limit for mobile devices is the "Specific Absorption Rate" (SAR), and the SAR limit is 2.0 W/kg averaged over 10 grams of body tissue. It meets the requirements of the International Commission on Non-Ionizing Radiation Protection (ICNIRP).

For body worn operation, this device has been tested and meets the ICNIRP exposure guidelines and the European Standard, for use with dedicated accessories. Use of other accessories which contain metals may not ensure compliance with ICNIRP exposure guidelines.

Hereby, Acer Incorporated declares that the radio equipment type T7c is in compliance with Directive 2014/53/EU. The full text of the EU declaration of conformity is available: Please search for Acer WAVE 7 Wi-Fi Mesh Router at [www.acer.com](http://www.acer.com)

### 17.13 Restrictions

Restriction or Requirement in the CE: 5150 to 5350 MHz indoor-use only.

	AT	BE	BG	CH	CY	CZ	DE
	DK	EE	EL	ES	FI	FR	HR
	HU	IE	IS	IT	LI	LT	LU
	LV	MT	NL	PL	PT	RO	SE
	SI	SK	TR	NO	UK(NI)		

WLAN 5GHz Band: For indoor use only.

	UK
---	----

### 17.14 EU Regulatory Compliance -- Radio

e.i.r.p power limit											
2.4G		5G(U-NII-1)		5G(U-NII-2a)		5G(U-NII-2b)		5G(U-NII-3)		6E(U-NII-5)	
2400 MHz ~	2483.5 MHz	5150 MHz ~	5250 MHz	5250 MHz ~	5350 MHz	5470 MHz ~	5725 MHz	5725 MHz ~	5850 MHz	5945 MHz ~	6425 MHz
e.i.r.p 20dBm		e.i.r.p 23dBm		e.i.r.p 20dBm		e.i.r.p 27dBm		e.i.r.p 13.98dBm		e.i.r.p 23dBm	