

# Amazfit Nexo User Manual

Quick start.....	2
Appearance.....	2
Wear and Change Watch Straps.....	3
Turn On/Off .....	4
Pair with Your Mobile Phone .....	4
Basic Operations .....	5
Charging.....	6
Open Apps.....	7
App Notifications .....	7
Low Light Mode .....	8
Control Center.....	8
Device Status Icons .....	9
Activity.....	12
Start an Activity .....	12
GPS Search .....	13
Activity Settings.....	14
Interval Training .....	15
During Activities.....	15
Activity Pause and Stop .....	15
View Activity Records.....	16
Heart Rate .....	17
Sleep.....	19
Health.....	20
Network Communication.....	21
eSIM Card .....	21
Wi-Fi Network .....	21
Phone Calls .....	21
SMS.....	22
Contacts.....	22
Features .....	23
Watch Face Switch and Sorting.....	23
Music.....	25
Weather .....	26
Compass .....	26
Alarm Clock.....	26
Stopwatch.....	27
Timer.....	27
Data Import/Export .....	27
Check for Upgrade .....	28

# Quick start

## Appearance

---

Button, Screen, Air pressure sensor hole, Speaker hole, Heart rate sensor, Charging and data transmission port, Microphone

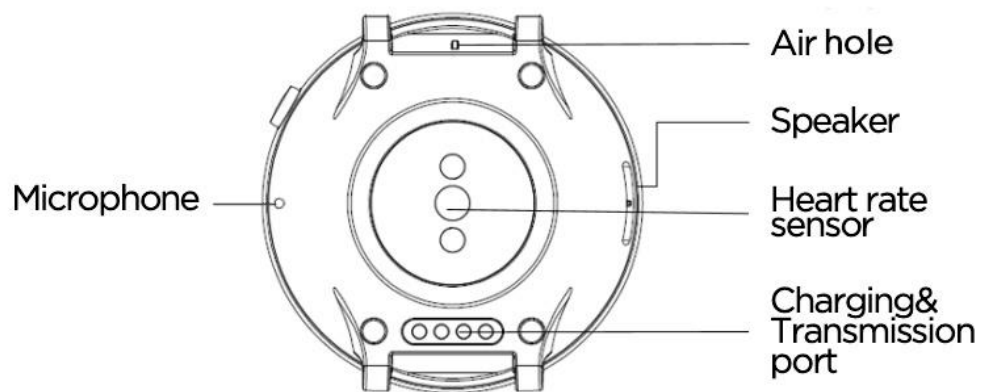
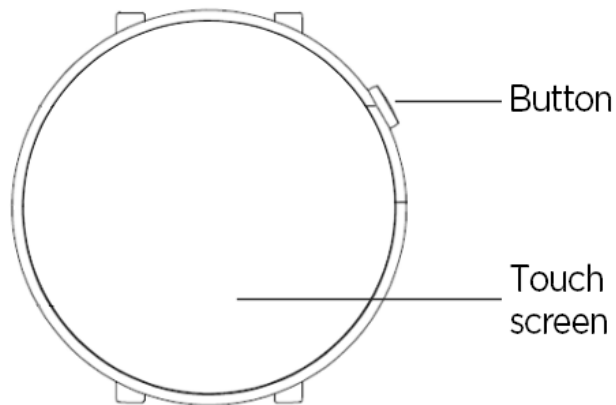

# Wear and Change Watch Straps

---

It is recommended that the watch should be worn on the wrist as illustrated in the picture, comfortably with a tight fit. Being too tight or too loose will affect the normal data detection of the optical heart rate monitor.

During activities, it's recommended to wear the watch comfortably and ensure a tight fit without slipping. Don't be too tight and ensure that the watch doesn't move freely.

**Note: Use sports watch straps when working out.**

Removing or installing a watch strap: Remove and replace the strap according to the method shown in the picture.

Removing your strap

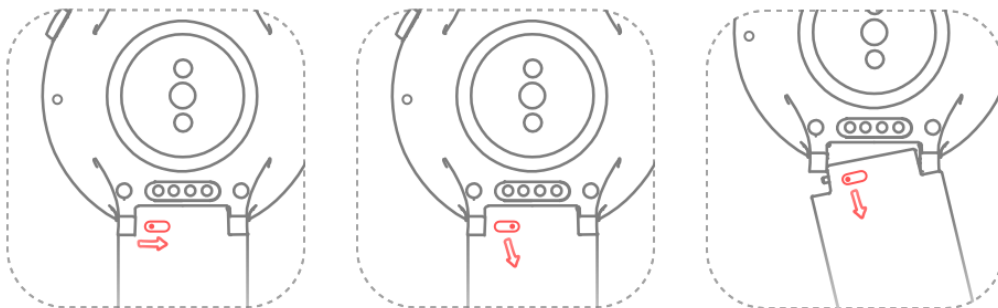

Fastening your strap

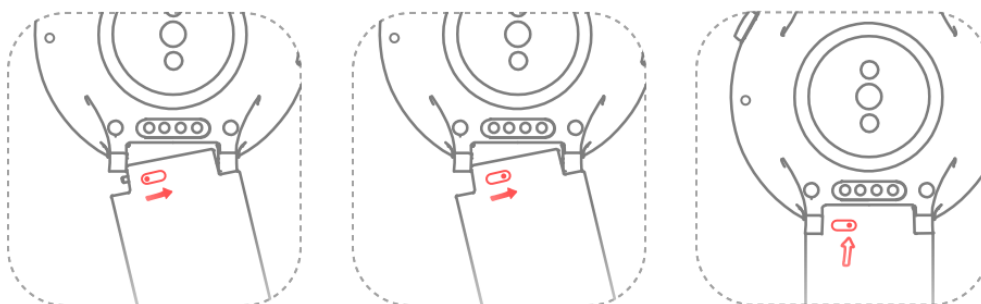

# Turn On/Off

---

## Turn on

Long press the button on the right side of the watch, and the watch screen will light up to display the splash screen.

## Turn off

When the watch is powered on, long-press the side button for more than 5 seconds to enter the shutdown menu, where you can select Power off or Reboot.

## Force reboot

When the watch is powered up, press the side button for more than 10 seconds to force a reboot.

# Pair with Your Mobile Phone

---

## Initial activation

1. When the watch is activated for the first time, the QR code for binding will be displayed on the screen.
2. Install and open the Amazfit app on your mobile phone, login and follow the prompts to scan the QR code displayed to pair with the watch.

## Pair with a new mobile phone

1. Complete watch data synchronization on the Amazfit app of your old mobile phone.
2. On the old mobile phone, Please go to the APP>Profile>Amazfit Nexo>More settings>Click Unpair button to unpair the watch.
3. The watch will be restored to factory settings and rebooted, and it will be paired with the new mobile phone as it's activated for the first time.

# Basic Operations

---

Tab the screen

To select the current item or move on to the next step

---

Short press the button

To unlock the watch, return to the watch face or lock the screen

---

Long press the button

To turn on the watch, enter the Power off/Reboot page and force shutdown

---

Long press the screen

To activate watch face selection and settings on the Watch Face page

---

Slide the screen up/down or left/right

To scroll or switch pages

# Charging

---

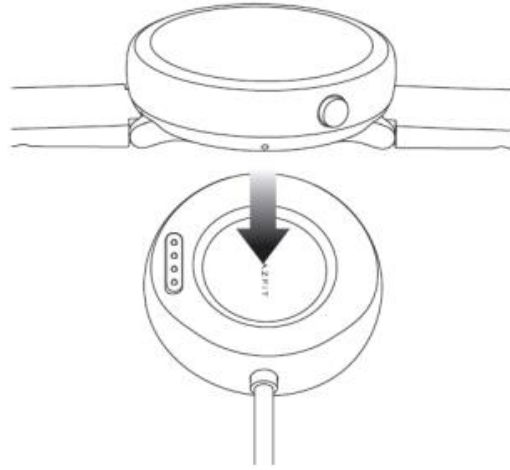

Connect the watch to the charging base as shown in the picture, and plug the other end of the USB cable into the USB power adapter. At this time, the watch will show the charging status. Pay attention to the correct direction of installation and press tightly to make sure the watch won't slide loose from the base.

Charging requirement: Use the recommended computer USB ports or brand mobile phone chargers to charge the band. The rated input voltage of such mobile phone chargers must be DC 5.0V, and the input current must be greater than 500mA.

**Note: Dry the charging contacts before charging so as not to cause bad contact and failure to charge by sweat or other dirt.**

# Open Apps

---

"App" refers to each function on the watch that can be used independently, such as sleep, heart rate and compass.

How to open it

1. Short press the button on the Watch Face page, and slide the screen left and right to browse the app list.
2. Long press the app icon to view the app name.
3. Tap on the app to open it.

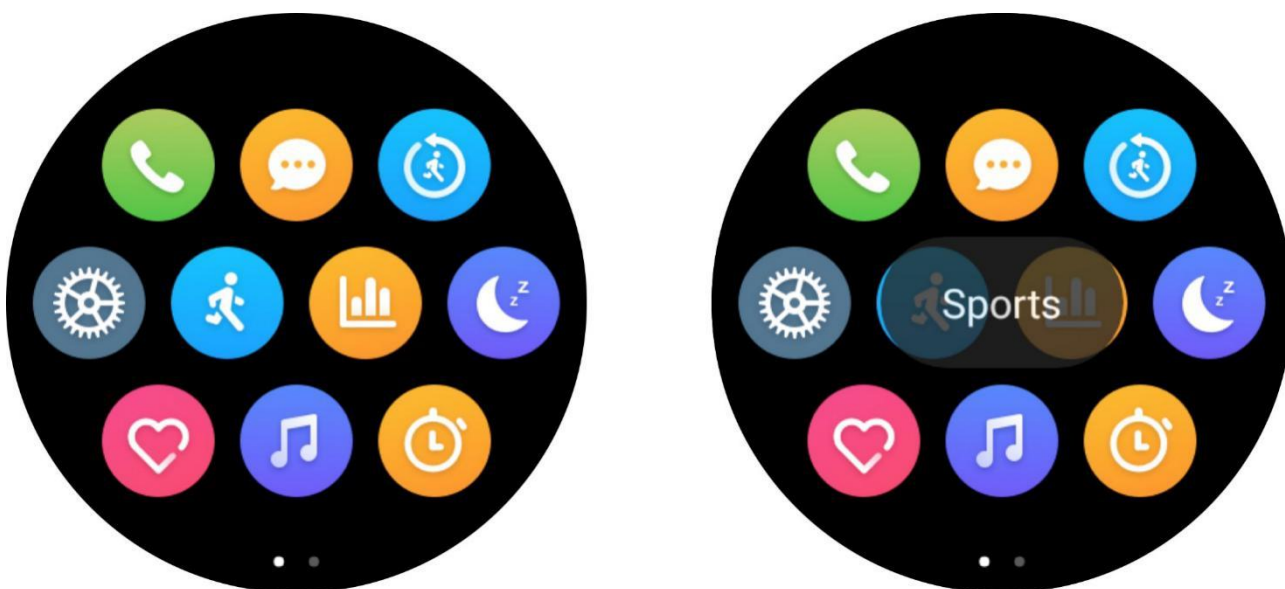

# App Notifications

---

After the watch is connected to the mobile phone, the notification messages of the mobile phone can be displayed on the watch. You can clean, block or take the messages as sticky on top as you like.

How to set it up

1. Open the Amazfit app on your mobile phone.

2. Turn on apps that allow notifications on Profile > Amazfit Nexo > Notification Settings > App Blacklist Settings.

**Note:** If you're using an Android device, you have to include the Amazfit app in the white list or the self-starting list of the mobile phone in background settings. You also have to keep the app running in the background to protect it from being detected and killed by the mobile phone's background processes, which could disconnect the watch from the app, and as a result no app reminder will be received.

## Low Light Mode

---

Under the standby status, the display can be in Off Screen or Low Light mode. By default, it's in the Off Screen mode. You can enter Settings > Display and Brightness > Low Light Mode on the watch, and switch through the on/off control of Low Light mode.

### Low Light mode

When the Low Light mode is turned on, you can view the time on the watch under the standby status (the pointer dial plate displays the pointer, and the digital dial plate displays digital time). When there's a message notification, the content will be displayed.

**Note:** Turning on the Low Light mode will reduce the endurance of the watch.

## Control Center

---

Slide down from the top of the watch face to activate the Control Center, and you can turn on/off some frequently-used features and switch





modes on that surface. Long press the icon to enter the Settings page for the corresponding feature.

## Device Status Icons

---



Power off

---



Airplane mode off



Airplane mode on



Cellular off



Cellular on



Cellular 4G



Flashlight off



Flashlight on



Battery saver mode off, not charging



Battery saver mode on, not charging



Battery saver mode on, charging

---



WLAN off



WLAN on



DND off



DND on



Silent mode on



Sounds on



Bluetooth off



Bluetooth on, not connected



Connected to the mobile phone, not connected to other devices



Connected to other devices, not connected to the mobile phone

# Activity

---

Amazfit Nexo features 10 activity modes, including Run, Walk, Cycling, Run indoor, Indoor cycling, Elliptical Trainer, Climb, Trail Run, Soccer, and Jump rope.



## Start an Activity

---



After entering the preparation page of outdoor activities such as Run, the watch will automatically search GPS. When the search is complete, tap GO to start running. On the page of indoor activities such as Elliptical Trainer, you can directly tap GO to start your activity.

## GPS Search

---

On the preparation page of outdoor activities, the watch will automatically start GPS positioning and remind you immediately after the positioning is successful. And the GPS positioning will automatically turn off when you leave the activity preparation page or your activity is finished.

GPS can continue searching for 3 minutes. If the positioning doesn't succeed during that time, it will prompt you to proceed with positioning. If you do not start your activity one hour after successful positioning, the watch will automatically turn off the positioning state to save its battery. If you continue to use it, you'll need to position it again.

Positioning suggestions

Please proceed with the GPS positioning in a flat, open outdoor area, and you can start an activity once it succeeds. If you're among the crowds, you can raise your arm to the height of your chest to speed up the positioning process.

### Assisted Global Positioning System (AGPS)

AGPS refers to a kind of GPS satellite orbit data, which helps the watch to speed up the GPS positioning process.

When the watch is connected with 4G/WLAN network, it will automatically update the AGPS data. If the watch isn't connected with 4G/WLAN network for seven days in a row, the AGPS data will expire. The positioning speed may be affected after expiration. When you start an activity, the watch will remind you to update.

## Activity Settings

---

Slide up the activity preparation page to display the "Settings" entry, and tap on the entry to adjust the running settings.

### Activity reminder

Activity reminders provide you with control over all kinds of reminders, such as Lap alert and heart rate alert. You can program it in Activity Settings.

### Auto Lap

Auto Lap of mileage can be set during your activity such as Run and an auto lap reminder can be turned on. The watch will record the activity details of the lap at each lap node. You can check the lap details after the completion of an activity.

### Accessories connection

The watch supports connecting to A2DP Bluetooth headset. You can pair or connect the devices in the Accessories Connection Settings under the Activity Settings for use during your activity.

# Interval Training

---

Open Amazfit App >> Profile >> My Watch Amazfit Nexo >> App management >> Sports >> select Interval workout to configure the interval workout that suits you best.

## During Activities

---

### Switch data screens

After the screen is lit from the standby mode during an activity, each data screen can be switched by sliding left and right. The leftmost screen is the activity operation interface. Other screens are data items and the chart screens of other activity modes.

### Change data items

You can configure the display of real-time sports data items in Real-time sports data settings by clicking Sports in App Settings from the Amazfit App  Profile  Amazfit Nexo page..

## Activity Pause and Stop

---

## Activity pause



Tap the physical button to make an activity pause in the unlocked state, and tap the button again to resume the activity. Or slide to the leftmost interface, and you can also tap the Pause button to control your activity.

## Activity stop

After pause, select Save to end your activity, select Resume to return to the activity mode and select Discard to leave the current activity unsaved. When your activity ends, the watch will display and save the details of this activity, and you can check them again on the watch or the Amazfit app.

# View Activity Records

---

View on the watch



Start the activity recording app on the watch to view the most recent activity profile, and tap the screen to view a list of all activity records. By selecting any record and sliding up and down the screen, you can view the information about your duration, pace, consumption, heart rate, heart rate curve and icon, etc. By sliding left and right on the screen, you can also view the trajectory map of the activity, export the map or delete the activity record.

View on the phone

On the Activity page of the Amazfit app, you can view all the activity details that have been successfully synced from the watch.

## Heart Rate

---

There are two modes of heart rate measurement: The "single measurement" mode and "all-day heart rate" mode, which can be switched in the heart rate app.

**Note: In order to improve the accuracy of heart rate measurement, please wear the watch correctly, keep your wrist clean and avoid the application of sunscreen when wearing the watch.**

Single measurement

You can measure your heart rate manually when you need it. Please keep relatively still when measuring so that the watch can output heart rate data more accurately.

All-day heart rate

When the All-Day Heart Rate mode is turned on, the heart rate app will display your heart beats per minute (bpm), the average heart rate when you aren't working out, the maximum and minimum heart rate, and the resting heart rate of the day. (You have to wear the watch to sleep in order to evaluate it.)

These data can be viewed on the watch and on the Amazfit app.

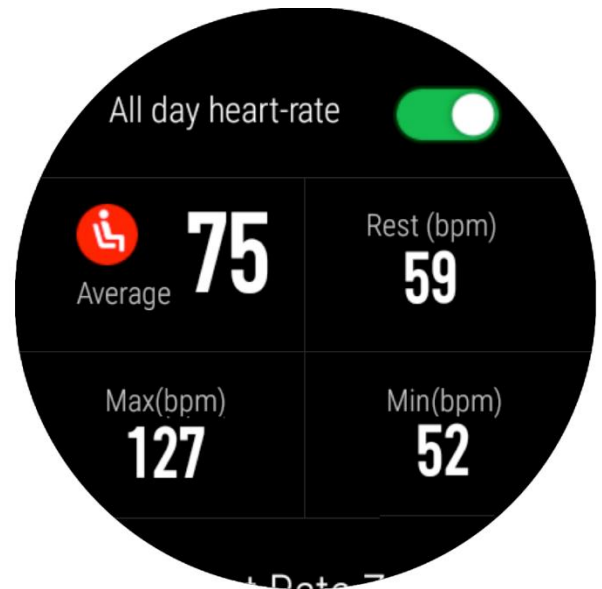

Note: Turning on the All-Day Heart Rate mode will reduce the endurance of the watch.

# Sleep

---

When you wear the watch to sleep at night, it will monitor your sleep status and give a data analysis of "hours of sleep," "deep sleep," "light sleep" and other data after you get up the next day. Tap on the Today's sleep interface to enter the sleep history.



## View sleep data

- Tap on the sleep app on the watch to enter and view.
- After synchronizing the data, turn on Amazfit App > Workout > Status > Sleep to view them.

# Health

---

The steps, consumption, and cumulative movement statistics you generate every day when you wear the watch will be summed up here. Tap on the screen on the health interface to view detailed data charts, such as activity time distribution diagrams and historical data lists.

Every Monday at 9 a.m., it will also generate a weekly data report of the previous week for you, making it easy to view the report on your overall activities and health for the previous week.



# Network Communication

## eSIM Card

---

The eSIM card is a virtual SIM card service provided by carriers. After activating the service on your watch, you can independently make calls, receive SMS and use cellular mobile network and other features.

Amazfit Nexo supports the eSIM card. You can open the Amazfit app on your mobile phone to enter the "eSIM card" on the corresponding watch information page, activate the service and set it up according to instructions.

## Wi-Fi Network

---

By connecting to the Wi-Fi network, your watch can directly use network services to sync your account data to the cloud.

How to set it up

1. On the watch, enter App List > Settings > Network and Connection > WLAN, enable it and choose the corresponding network.
2. On the mobile phone, open the Amazfit app, enter the corresponding password in the automatic pop-up page to connect.

## Phone Calls

---

The phone call feature can be used independently through the eSIM card, and both making and answering phone calls can be completed on the watch.

Open the phone call app on the watch, slide the screen left and right to view the contacts and the most recent call records, make calls and set up an incoming call reminder.

# SMS

---

The SMS feature can be used independently through the eSIM card. Whether the text messages can be received or not is based on the carrier. At present, the SMS sending function isn't currently supported.

# Contacts

---

If the contact list of the phone call and SMS features is synced from the contacts of your mobile phone, make sure the Amazfit app is given permission and allowed to read your contacts.

# Features

## Watch Face Switch and Sorting

---

### Switch watch faces

After the watch is awakened, sliding left and right on the watch face interface can switch and display other enabled watch faces.

### Sort watch faces

Enter Amazfit App > Profile > My Watch > Watch Face Management on the phone, tap "Sort" in the upper-right corner. Then, you can long-press and drag the faces up and down to move them. It's easy to arrange the display order of the watch faces.

## Shortcut Components

---

You can view various information such as steps, calories, sleep and weather without entering the app through the shortcut components of the watch face, or



you can tap the component to open the corresponding app.

Application (taking the classic watch face in the picture above as an example):

- In the step shortcut component (orange), you can view the information that 5,000 steps have been taken today. Tap on the component to start the health app and jump to the step interface.
- In the missed call shortcut component (on the left of the circle), you can view the number of missed calls. By tapping on the component, you can jump to the call record and view calls, call back and so on.



# Music

---

The music player can play MP3 music files copied to your watch's Music directory. You can use Music Settings to change the playback order and adjust the volume of the music. This function also supports volume adjustment and song-switching control for a Bluetooth headset.

## Copy music files

1. Connect the watch to the charging base and plug the USB interface into the computer mainframe. (We recommend that the computer have the Windows 7/8/10 system installed.)
2. Find the hard disk of the watch in "My Computer." Open the Music folder in the watch's directory.
3. Copy the music files in MP3 format to the above folder. Successful copying completes the process.

## Play music

The watch can play audio directly and connect to a Bluetooth headset to play.

## Connect to a Bluetooth headset

The watch supports a Bluetooth headset connected to A2DP. After the first connection, the watch will automatically connect to the headphone each time it's turned on.

## How to connect it

1. First, put the Bluetooth headset into the pairing mode (for a common Bluetooth headset, long-press the headphones' power button for about 5 seconds, and the Bluetooth indicator lights will flicker the red and blue lights to enter the pairing mode).

2. Open the Bluetooth device search page of the watch, search for a Bluetooth headset and tap the desired connection.

## Weather

---

It enables you to check the weather conditions of the current location in recent days whenever you want. Tap on Today's Weather and you can also see the current air quality, wind speed, humidity and UV intensity information.

Weather data need to be synced through the mobile phone network, so it's necessary to maintain the connection to the mobile phone in order to update the changes of the weather in a timely manner.

## Compass

---

Calibration is required for the first time to use.

Tap on the compass interface to enter the information interface of longitude and latitude. The longitude and latitude information can be obtained by communicating with a GPS signal in an open outdoor area. Keep away from any magnetic field when in use in order to avoid any disturbance to the signal.

## Alarm Clock

---

You can add an alarm alert on the watch as needed and set whether to repeat the alert with the alarm clock. It also supports deleting the alarm that is no longer needed.

The alarm clock will remind you by vibrating the watch at the set time. You can choose to turn it off or to set the repeat option so that it will remind you later. If nothing is done when the watch is vibrating, the vibration will only last five minutes and be off.

# Stopwatch

---

The stopwatch can record the time for multiple times.

# Timer

---

You can set countdown. When a timer goes off, the watch will vibrate to remind you.

# Data Import/Export

/Music/

Store .mp3 files

---

/gpxdata/

Store .gpx track files

---

/WatchFace/

Store external import

---

## Connect to PC

After the watch is connected to the charging base and to the USB port of the computer, double-click "Amazfit Nexo" in "My Computer" to enter, then double-click "Internal Storage Device" to access the list of files in the watch.

**Note: Computers with systems below Windows XP SP2 need to have an MTP driver installed to connect to the watch.**

## Connect to Mac

If you're using a Mac device, the Android File Transfer tool needs to be installed before it can connect to the watch. After the watch is connected to the charging base and to the USB port of the computer, the Android File Transfer tool will automatically pop up and display the list of files in the watch.

### Import/Export

When you can access the watch through your computer, some folders will be displayed in the root directory of the watch. You can copy the corresponding files into these folders or back them up to your computer.

## Check for Upgrade

---

Regular upgrade of the watch system can continuously improve and optimize the watch system, and each upgrade will also fix the problems found before.

**Note: Keep the watch power above 40% before upgrading, and ensure a stable Wi-Fi connection during the upgrade. This will ensure a smooth process.**

### Check for upgrades on the watch

You can check whether the current version of the watch is the latest in Watch > Settings > Check for Upgrades.

### Check for upgrades on the mobile app

In the Amazfit app, you can go Amazfit Nexo>>Additional Settings>>Rom updates check whether the watch system needs to be upgraded.