



by Schneider Electric

User Manual Easy UPS On-Line Battery Pack SRV36BP-9A, SRV72BP-9A, SRV240BP-9A SRV36RLBP-9A, SRV72RLBP-9A, SRV240RLBP-9A

Important Safety Information

Read the instructions carefully and look at the equipment to become familiar with the device before trying to install, operate, service or maintain it. The following special messages may appear throughout this document or on the equipment to warn of potential hazards or to call attention to information that clarifies or simplifies a procedure.



The addition of this symbol to either a “Danger” or “Warning” safety label indicates that an electrical hazard exists which will result in personal injury if the instructions are not followed.



This is the safety alert symbol. It is used to alert you to potential personal injury hazards. Obey all safety messages that follow this symbol to avoid possible injury or death.

⚠ DANGER
DANGER indicates a hazardous situation which, if not avoided, **will result in death** or serious injury.

⚠ WARNING
WARNING indicates a hazardous situation which, if not avoided, **could result in death** or serious injury.

⚠ CAUTION
CAUTION indicates a hazardous situation which, if not avoided, **could result in minor or moderate injury**.

NOTICE
NOTICE is used to address practices not related to physical injury.

Product Handling Guidelines



<18 kg
<40 lb



18-32 kg
40-70 lb



32-55 kg
70-120 lb



>55 kg
>120 lb



For Professional Business Applications – Not For Consumer Use

Safety and General Information

SAVE THESE INSTRUCTIONS

This manual contains important instructions that should be followed during installation and maintenance of the battery pack.

Inspect the package contents upon receipt. Notify the carrier and dealer if there is any damages.

- This external battery pack is for indoor use only.
- Do not operate this battery pack in direct sunlight, in contact with fluids, or where there is excessive dust or high humidity.
- Do not operate the battery pack near open windows or doors.
- Be sure the air vents on the battery pack are not blocked. Allow adequate space for proper ventilation.

Note: Allow a minimum of 20 cm clearance on all four sides of the external battery pack.

- Environmental factors impact battery life. Elevated ambient temperatures, poor quality utility power, and frequent discharges will shorten battery life. Follow the battery manufacturer recommendations.

Battery safety

⚠ CAUTION

RISK OF HYDROGEN SULPHIDE GAS AND EXCESSIVE SMOKE

- Replace the battery at least every 5 years.
- Replace the battery immediately when the UPS indicates battery replacement is necessary.
- Replace battery at the end of its service life.
- Replace batteries with the same number and type of batteries as originally installed in the equipment.
- Replace the battery immediately when the UPS indicates a battery over-temperature condition, or UPS internal over-temperature, or when there is evidence of electrolyte leakage. Power off the UPS, unplug it from the AC input, and disconnect the batteries. Do not operate the UPS until the batteries have been replaced.
- *Replace all battery modules (including the modules in External Battery Packs) which are older than one year, when installing additional battery packs or replacing the battery module(s).

Failure to follow these instructions can result in minor or moderate injury and equipment damage.

* Contact APC by Schneider Electric Worldwide Customer Support to determine the age of the installed battery modules.

- Servicing of user replaceable batteries should be performed or supervised by personnel knowledgeable about batteries and required precautions. In this case, batteries is not user replaceable.
- APC by Schneider Electric uses Maintenance-Free sealed Lead Acid batteries. Under normal use and handling, there is no contact with the internal components of the batteries. Over charging, over heating or other misuse of batteries can result in a discharge of battery electrolyte. Released electrolyte is toxic and may be harmful to the skin and eyes.
- Use tool with insulated handles.
- Wear rubber gloves and boots.
- Determine if battery is either intentionally or inadvertently grounded. Contact with any part of a grounded battery can result in electric shock and burns by high short-circuit current. The risk of such hazards can be reduced if grounds are removed during installation and maintenance by a skilled person.
- This equipment contains potentially hazardous voltages. Do not attempt to disassemble the unit. The unit contains no user serviceable parts. Repairs are must performed only by factory trained service personnel.
- Do not dispose of batteries in a fire. The batteries may explode.
- Do not open or mutilate batteries. They contain an electrolyte that is toxic and harmful to the skin and eyes.
- Do not connect the terminals of a battery or battery pack with a wire or other electrically conductive objects.

Product Description

The APC by Schneider Electric external battery pack connects to selected APC by Schneider Electric Uninterruptible Power Supply (UPS) models. The UPS and the external battery pack provide extended protection for electronic equipment from utility power blackouts, brownouts, sags, and surges. The external battery pack provides continuous power until utility power returns to normal levels or the batteries are fully discharged. The UPS and the external battery pack are packed separately.

This user manual is available on the APC by Schneider Electric website, www.apc.com.

Package Contents

Read the Safety Guide before installing the battery pack.

The packaging is recyclable; save it for reuse or dispose of it properly.

SRV36BP-9A/ SRV72BP-9A

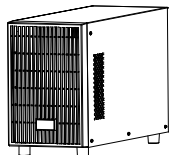

(1)
Battery pack



(1)
User manual

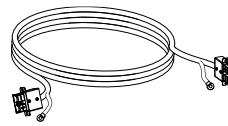

L=600mm
(1)
Battery cable

SRV240BP-9A

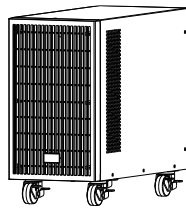

(1)
Battery pack



(1)
User manual

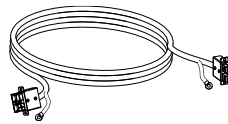

L=600mm
(1)
Battery cable

SRV36RLBP-9A/ SRV72RLBP-9A

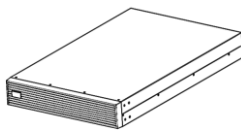

(1)
Battery pack



(1)
User manual

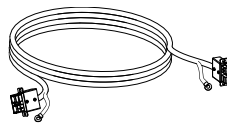

L=600mm
(1)
Battery cable



(8)
Flat head screws

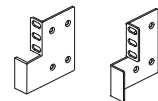

(2)
Rack-mount bracket

SRV240RLBP-9A

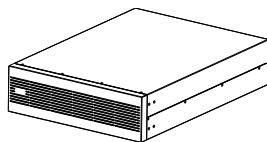

(1)
Battery pack



(1)
User manual



L=600mm
(1)
Battery cable



(8)
Flat head screws

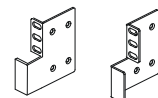

(2)
Rack-mount bracket

Note: The model and serial numbers are located on a small, rear panel label.

Optional accessories

For optional accessories, refer to the APC by Schneider Electric Website at www.apc.com.

Specifications

Environment specifications

NOTICE

RISK OF EQUIPMENT DAMAGE



- Battery pack must be used indoors only.
- The installation location should be sturdy to withstand the weight of the battery pack.
- Do not operate battery pack where there is excessive dust or where the temperature or humidity are outside specified limits.

Failure to follow these instructions can result in equipment damage.

Temperature	Discharge	-15° to 50°C	<p>This unit is intended for indoor use only. Select a location sturdy enough to handle the weight.</p> <p>Do not operate the battery pack where there is excessive dust or where the temperature or humidity are outside specified limits.</p> <p>Be sure the air vents on the battery pack are not blocked. Allow adequate space for proper ventilation.</p>
	Recharge	0° to 40°C	
	Storage	-15° to 40°C During storage, charge the battery pack every 4 months.	
Elevation	Operating	0 - 1,000 m: normal operation	
	Storage	0 - 15,000 m	
Humidity		0 to 95% relative humidity, non-condensing	
International Protection Code		IP20	



Physical specifications

Tower Model

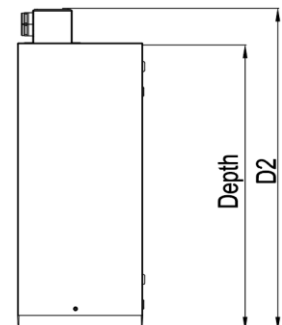
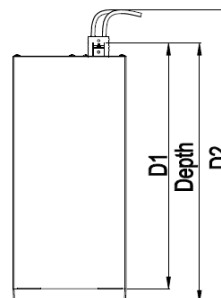
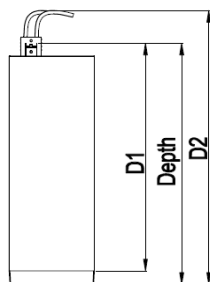
Model	SRV36BP-9A	SRV72BP-9A	SRV240BP-9A
Dimensions with package Width x Height x Depth	235 mm (9.3 in) x 355 mm (14 in) x 525 mm (20.7 in)	325 mm (12.8 in) x 465 mm (18.3 in) x 565 mm (22.2 in)	290 mm (11.4 in) x 460 mm (18.1 in) x 570 mm (22.4 in)
Dimensions without package Width x Height x Depth	145 mm (5.7 in) x 228 mm (9.4 in) x 414 mm (16.3 in) *D1=391mm, D2=441mm	190 mm (7.5 in) x 336 mm (13.2 in) x 425 mm (16.7 in) *D1=402mm, D2=463mm	190 mm (7.5 in) x 368mm (14.5 in) x 485mm (19.1 in) * D2=487mm
Weight with package	20.8kg	40.2kg	63kg
Weight without package	19.6kg	38kg	60kg
Lifting guidelines	18 - 32 kg (40 - 70lb) 	32 - 55 kg (70 - 120lb) 	>55 kg (>120lb) 



Rack Model

Model	SRV36RLBP-9A	SRV72RLBP-9A	SRV240RLBP-9A
Dimensions with package Width x Height x Depth	500 mm (19.7 in) x 240 mm (9.6 in) x 600 mm (23.6 in)	600 mm (23.6 in) x 240 mm (9.45 in) x 800 mm (31.5 in)	580 mm (22.8in) x 250 mm (9.84 in) x 870 mm (34.3 in)
Dimensions without package Width x Height x Depth	438 mm (17.2 in) x 86 mm (3.4 in) x 418 mm (16.5 in) *D1=390mm, D2=456mm	438 mm (17.2 in) x 86 mm (3.4 in) x 638 mm (25.1 in) *D1=610mm, D2=676mm	438 mm (17.2 in) x 133mm (5.2 in) x 626 mm (24.6 in) *D1=600mm, D2=660mm
Weight with package	24.2kg	53.1kg	70kg
Weight without package	21.0kg	42.5kg	63kg
Lifting guidelines	18 - 32 kg (40 - 70 lb) 	32 – 55 kg (70 – 120lb) 	>55 kg (>120lb) 

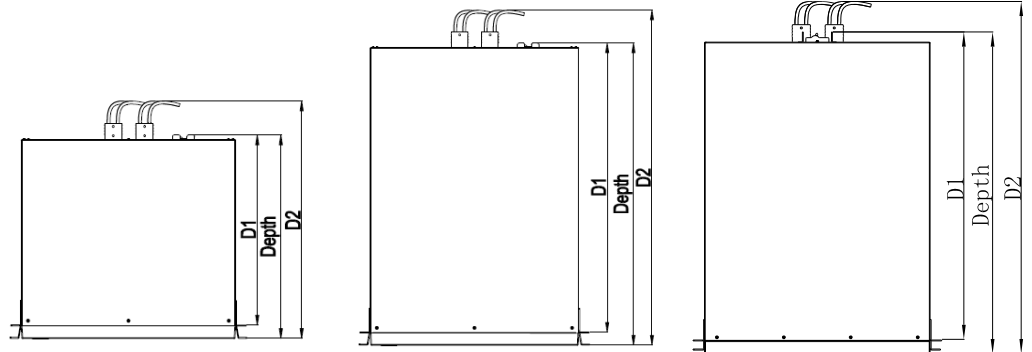

Battery

Tower Model

Battery Pack Model	SRV36BP-9A	SRV72BP-9A	SRV240BP-9A
Type	Sealed, maintenance-free, Valve Regulated Lead-Acid battery 12 V, 9 Ah		
Nominal Voltage	36 V	72 V	240 V
Battery Numbers	2 strings of 12V 9 Ah x 3	2 strings of 12V 9 Ah x 6	1 string of 12V 9 Ah x 20
Typical Capacity	648 Wh	1296 Wh	2160 Wh
Recommended Charging Voltage	40.8 V	81.6 V	272.0 V

Rack Model

Battery Pack Model	SRV36RLBP-9A	SRV72RLBP-9A	SRV240RLBP-9A
Type	Sealed, maintenance-free, Valve Regulated Lead-Acid battery 12 V, 9 Ah		
Nominal Voltage	36 V	72 V	240 V
Battery Numbers	2 strings of 12V 9 Ah x 3	2 strings of 12V 9 Ah x 6	1 string of 12V 9 Ah x 20
Typical Capacity	648 Wh	1296 Wh	2160 Wh
Recommended Charging Voltage	40.8 V	81.6 V	272.0 V

Rear Panel Features

SRV36BP-9A

SRV72BP-9A

SRV240BP-9A

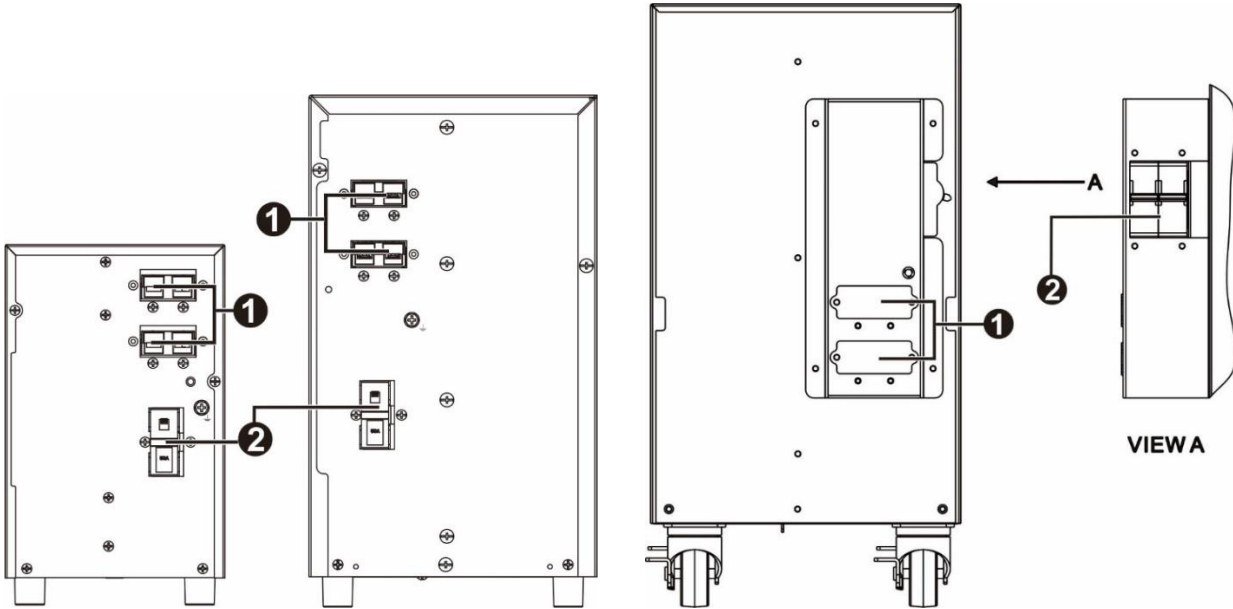

SRV36RLBP-9A/ SRV72RLBP-9A

SRV240RLBP-9A

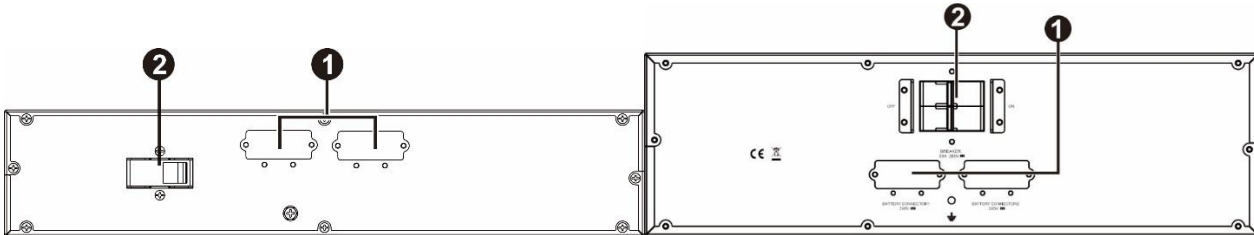

- ① Battery connector
- ② Circuit breaker

Rack-Mount Installation

⚠ CAUTION

RISK OF FALLING EQUIPMENT

- Practice correct lifting techniques adequate for the weight of the equipment.
- Install battery pack at the bottom of the rack.
- Install the UPS above the battery pack.
- Secure the rack-mount brackets to the unit using all of the screws supplied for this purpose.
- Secure the unit in the rack using all of the screws supplied for this purpose.

Failure to follow these instructions could result in equipment damage and minor or moderate injury.

- Before installing the battery pack into the 19 inch rack enclosure, be sure that the rack is already equipped with a shelf.
- Be sure that the installed shelf can withstand the weight of the UPS and/or battery pack. Otherwise, install an optional rail kit accessory SRVRK1 (for weight <60kg) and SRVRK2 (for weight <90kg) which can be purchased separately.

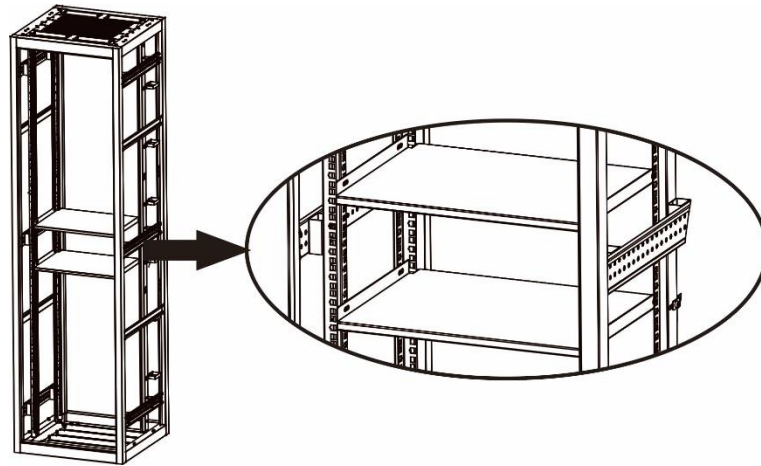

Follow the instructions below to secure and position battery pack into the 19 inch rack enclosure.

- 1 Secure two rack-mount brackets each to the battery pack. Use 4 screws in each bracket.

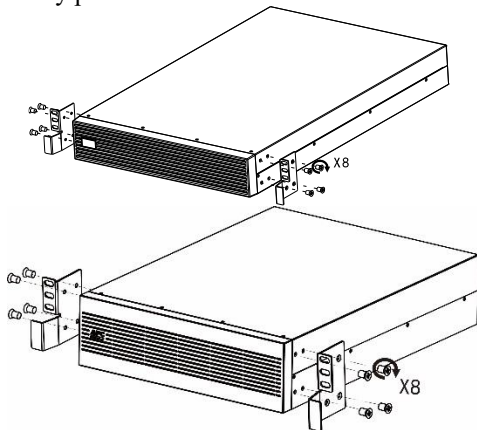

- 2 Lift the battery module and slide it into rack enclosure. Secure the battery module to the rack with screws, nuts and washers (not supplied in the package) through its mounting brackets into the rails.

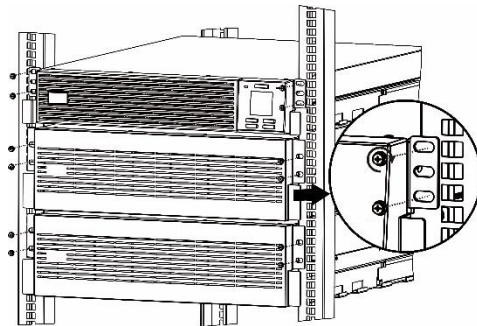

Connect the Battery

Rack Model

Attach the front bezel

The battery pack is shipped without front bezel. Attach the front bezel first before use (shown at right).

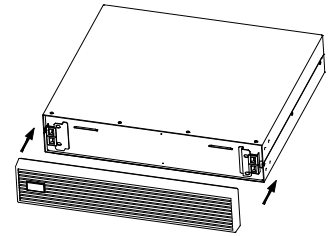

Connect to the UPS

Connect UPS to the external battery pack with a battery cable. Refer to below chart for external battery connection.

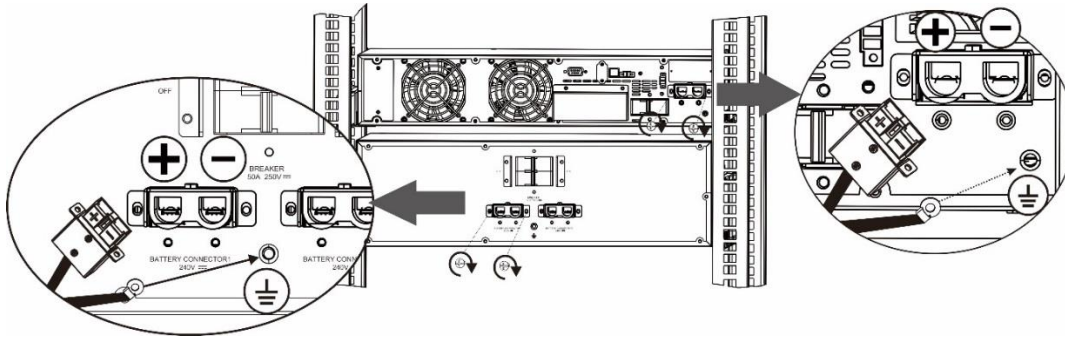

- Connect the battery according to the battery voltage indicated on the rear panel. If the connected battery voltage is incorrect, UPS may be damaged and cannot be repaired. Therefore, be sure to confirm that the battery voltage is in accordance with the UPS specification.
- Be sure to respectively connect red cable to the positive terminal and black cable to the negative terminal of external battery system. Be sure grounding (green cable) is connected firmly.

Connect a battery pack to another battery pack

If more than one battery pack connected to the UPS,

Step 1: Connect UPS to the #1 external battery pack with one battery cable (A).

Step 2: Use another battery cable (B) and plug one end into rear connector **1** on the #1 battery pack.

Step 3: Plug the other end of battery cable (B) into the rear connector **2** on the #2 battery pack.

Be sure grounding is connected firmly.

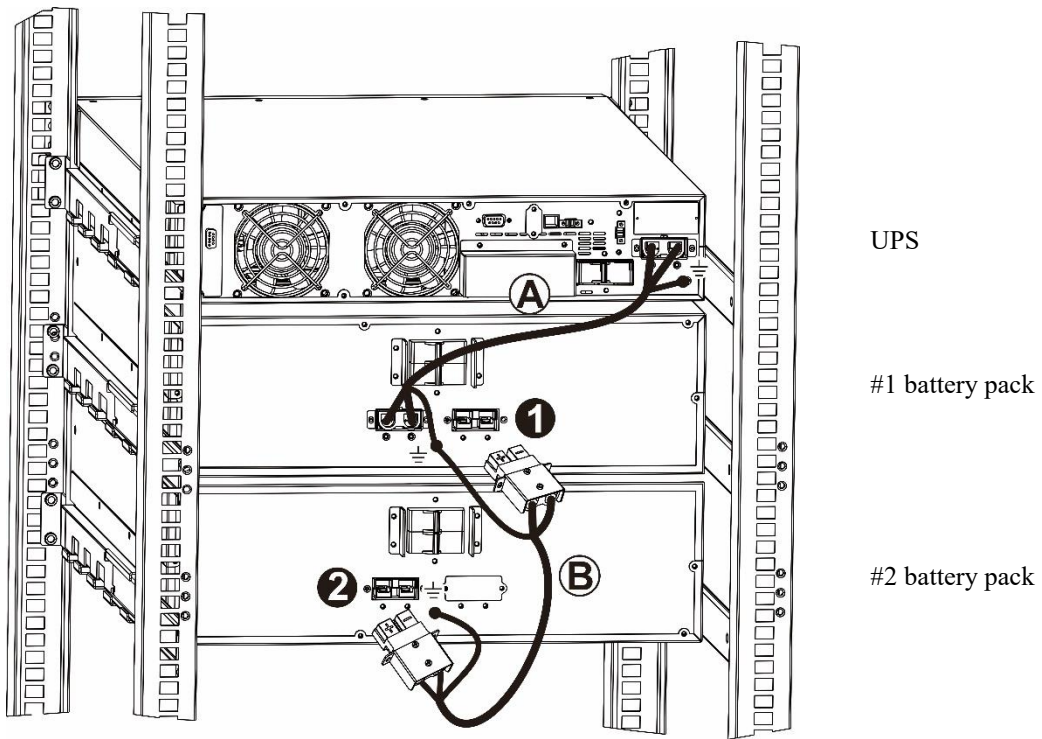

Tower Model

Connect to the UPS

Connect UPS to the external battery pack with a battery cable. Refer to below chart for external battery connection.

SRV36BP-9A/ SRV72BP-9A

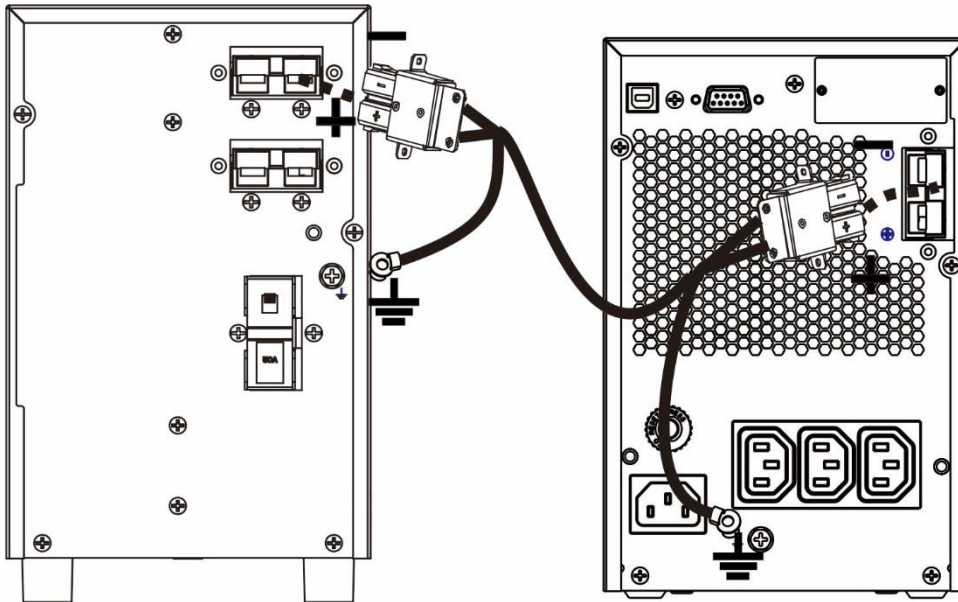

SRV240BP-9A

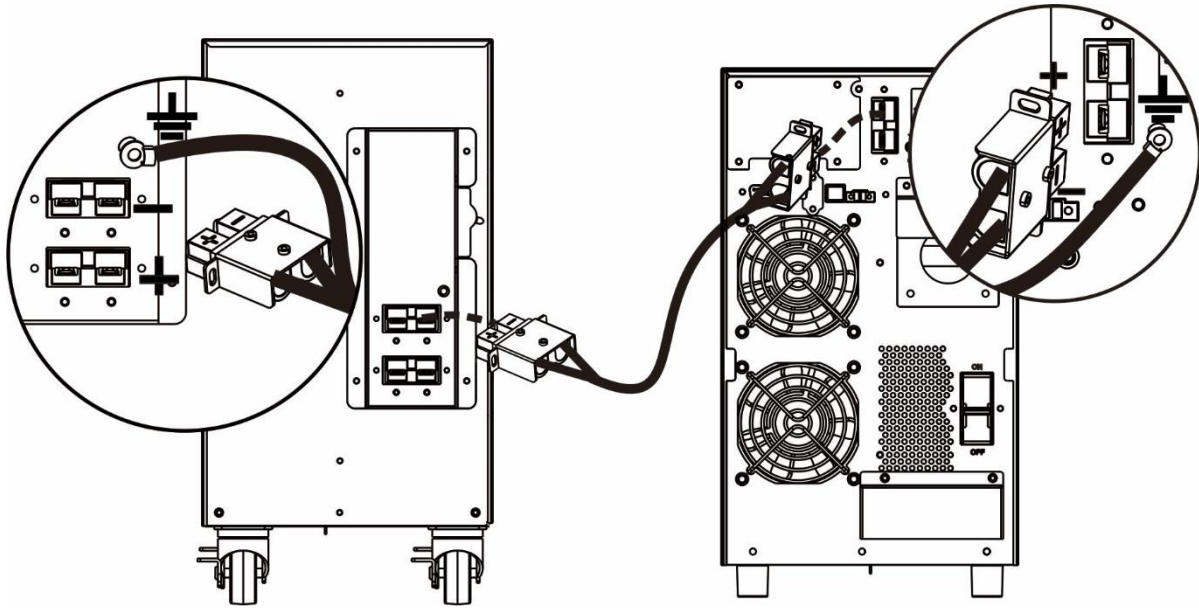

- Please connect the battery according to the battery voltage indicated on the rear panel. If the connected battery voltage is incorrect, UPS may be damaged and cannot be repaired. Therefore, be sure to confirm that the battery voltage is in accordance with the UPS specification.
- Be sure to respectively connect red cable to the positive terminal and black cable to the negative terminal of external battery system. Be sure grounding (green cable) is connected firmly.

Connect a battery pack to another battery pack

If more than one battery pack connected to the UPS,

Step 1: Connect UPS to the #1 external battery pack with one battery cable (A).

Step 2: Use another battery cable (B) and plug one end into rear connector **1** on the #1 battery pack.

Step 3: Plug the other end of battery cable (B) into the rear connector **2** on the #2 battery pack.

Be sure grounding is connected firmly.

SRV36BP-9A/ SRV72BP-9A

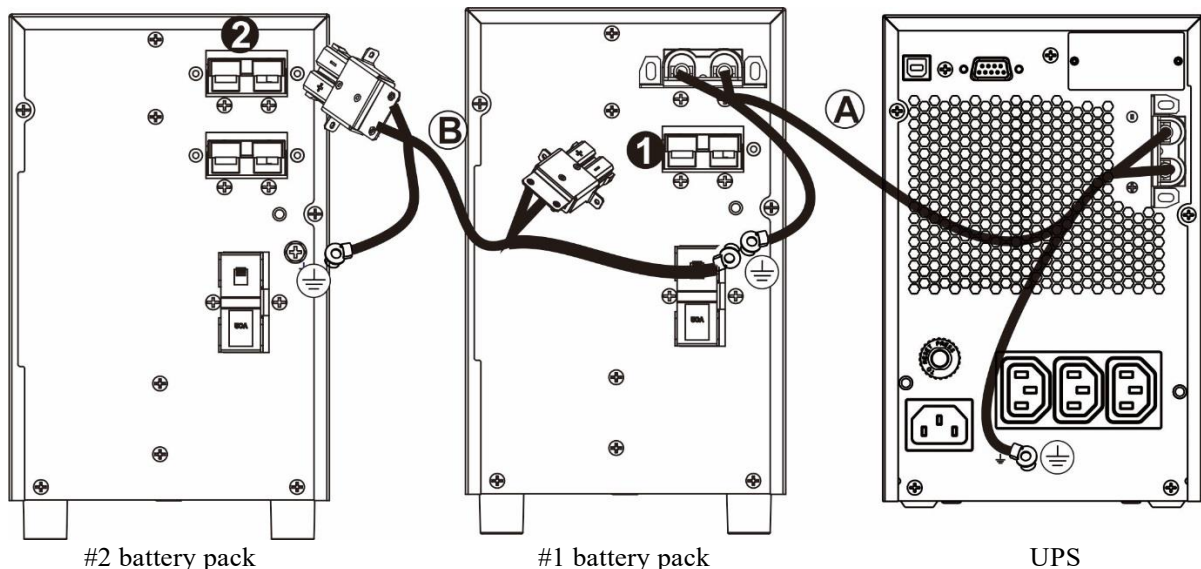

SRV240BP-9A

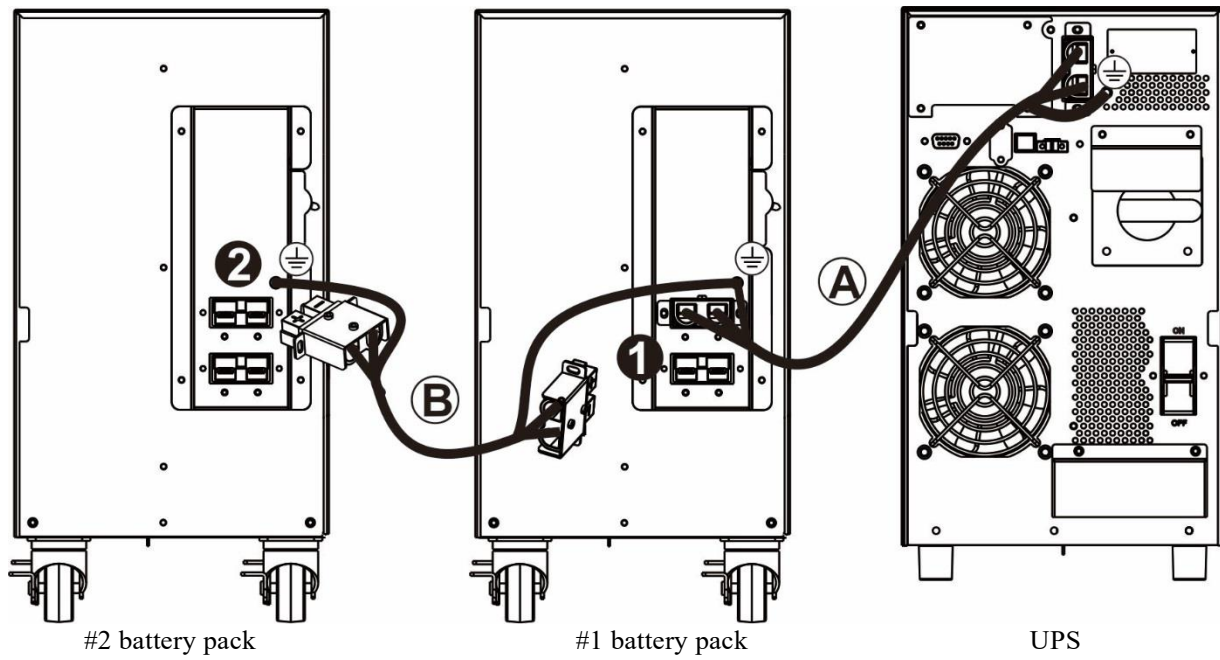

Troubleshooting

Use the table below to solve minor installation and operation problems.

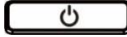
Problem and/or Possible Cause	Solution
UPS, when connected to battery, is not supplying power to the connected equipment	
The battery is not connected.	Connect battery to the UPS. See “Start Up Settings” section in UPS manual.
Low battery cut off. UPS may have discharged the battery due to utility power outage and turned the output off due to low battery condition.	Wait for the utility power to return and charge the battery. To turn on the output power after utility power returns, press  button.
UPS emits an audible beeping sound at long intervals	
The UPS is operating normally when running on battery.	UPS has detected an error. See “Alarms” section in UPS manual.
UPS is not providing expected backup time.	
The UPS battery is discharged due to a recent power outage.	The batteries require recharging after extended outages. Batteries can wear faster when put into service without proper recharging or when operated at elevated temperatures.
The battery is near the end of its service life.	If the battery is near the end of its service life, consider replacing the battery, even if the replace battery indicator is not illuminated. See “Start Up” section in UPS manual.

Transport

1. Shut down and disconnect all connected equipment.
2. Disconnect the unit from mains power.
3. Disconnect all internal and external batteries (if applicable).
4. Follow the shipping instructions outlined in the *Service* section of this manual.

Service

If the unit requires service, do not return it to the dealer. Follow these steps:

1. Review the *Troubleshooting* section of the manual to eliminate common problems.
2. If the problem persists, contact APC by Schneider Electric Customer Support through the APC by Schneider Electric website, **www.apc.com**.
 - a. Note the model number and serial number and the date of purchase. The model and serial numbers are located on the rear panel of the unit.
 - b. Call Customer Support. A technician will attempt to solve the problem over the phone. If this is not possible, the technician will issue a Returned Material Authorization Number (RMA#).
 - c. If the unit is under warranty, the repairs are free.
 - d. Service procedures and returns may vary internationally. For country specific instructions refer to the APC by Schneider Electric website, **www.apc.com**.
3. Pack the unit properly to avoid damage in transit. Never use foam beads for packaging. Damage sustained in transit is not covered under warranty.
4. Write the RMA# provided by Customer Support on the outside of the package.
5. Return the unit by insured, prepaid carrier to the address provided by Customer Support.

Limited Factory Warranty

Schneider Electric IT Corporation (SEIT), warrants its products to be free from defects in materials and workmanship for a period of two (2) years from the date of purchase. The SEIT obligation under this warranty is limited to repairing or replacing, at its own sole option, any such defective products. Repair or replacement of a defective product or part thereof does not extend the original warranty period.

This warranty applies only to the original purchaser who must have properly registered the product within 10 days of purchase. Products may be registered online at warranty.apc.com.

SEIT shall not be liable under the warranty if its testing and examination disclose that the alleged defect in the product does not exist or was caused by end user or any third person misuse, negligence, improper installation, testing, operation or use of the product contrary to SEIT recommendations of specifications. Further, SEIT shall not be liable for defects resulting from: 1) unauthorized attempts to repair or modify the product, 2) incorrect or inadequate electrical voltage or connection, 3) inappropriate on site operation conditions, 4) Acts of God, 5) exposure to the elements, or 6) theft. In no event shall SEIT have any liability under this warranty for any product where the serial number has been altered, defaced, or removed.

EXCEPT AS SET FORTH ABOVE, THERE ARE NO WARRANTIES, EXPRESS OR IMPLIED, BY OPERATION OF LAW OR OTHERWISE, APPLICABLE TO PRODUCTS SOLD, SERVICED OR FURNISHED UNDER THIS AGREEMENT OR IN CONNECTION HEREWITH. SEIT DISCLAIMS ALL IMPLIED WARRANTIES OF MERCHANTABILITY, SATISFACTION AND FITNESS FOR A PARTICULAR PURPOSE.

SEIT EXPRESS WARRANTIES WILL NOT BE ENLARGED, DIMINISHED, OR AFFECTED BY AND NO OBLIGATION OR LIABILITY WILL ARISE OUT OF, SEIT RENDERING OF TECHNICAL OR OTHER ADVICE OR SERVICE IN CONNECTION WITH THE PRODUCTS.

THE FOREGOING WARRANTIES AND REMEDIES ARE EXCLUSIVE AND IN LIEU OF ALL OTHER WARRANTIES AND REMEDIES. THE WARRANTIES SET FORTH ABOVE CONSTITUTE SEIT'S SOLE LIABILITY AND PURCHASER EXCLUSIVE REMEDY FOR ANY BREACH OF SUCH WARRANTIES. SEIT WARRANTIES EXTEND ONLY TO ORIGINAL PURCHASER AND ARE NOT EXTENDED TO ANY THIRDPARTIES.

IN NO EVENT SHALL SEIT, ITS OFFICERS, DIRECTORS, AFFILIATES OR EMPLOYEES BE LIABLE FOR ANY FORM OF INDIRECT, SPECIAL, CONSEQUENTIAL OR PUNITIVE DAMAGES, ARISING OUT OF THE USE, SERVICE OR INSTALLATION OF THE PRODUCTS, WHETHER SUCH DAMAGES ARISE IN CONTRACT OR TORT, IRRESPECTIVE OF FAULT, NEGLIGENCE OR STRICT LIABILITY OR WHETHER SEIT HAS BEEN ADVISED IN ADVANCE OF THE POSSIBILITY OF SUCH DAMAGES. SPECIFICALLY, SEIT IS NOT LIABLE FOR ANY COSTS, SUCH AS LOST PROFITS OR REVENUE, WHETHER DIRECT OR INDIRECT, LOSS OF EQUIPMENT, LOSS OF USE OF EQUIPMENT, LOSS OF SOFTWARE, LOSS OF DATA, COSTS OF SUBSTITUANTS, CLAIMS BY THIRD PARTIES, OR OTHERWISE.

NOTHING IN THIS LIMITED WARRANTY SHALL SEEK TO EXCLUDE OR LIMIT SEIT LIABILITY FOR DEATH OR PERSONAL INJURY RESULTING FROM ITS NEGLIGENCE OR ITS FRAUDULENT MISREPRESENTATION OF TO THE EXTENT THAT IT CANNOT BE EXCLUDED OR LIMITED BY APPLICABLE LAW.

To obtain service under warranty you must obtain a Returned Material Authorization (RMA) number from customer support. Customers with warranty claims issues may access the SEIT worldwide customer support network through the APC by Schneider Electric website: www.apc.com. Select your country from the country selection drop down menu. Open the Support tab at the top of the web page to obtain information for customer support in your region. Products must be returned with transportation charges prepaid and must be accompanied by a brief description of the problem encountered and proof of date and place of purchase.

APC by Schneider Electric Worldwide Customer Support

Customer support for this or any other APC by Schneider Electric product is available at no charge in any of the following ways:

- Visit the APC by Schneider Electric website to access documents in the APC by Schneider Electric Knowledge Base and to submit customer support requests.
 - **www.apc.com** (Corporate Headquarters)
Connect to localized APC by Schneider Electric websites for specific countries, each of which provides customer support information.
 - **www.apc.com/support/**
Global support searching APC by Schneider Electric Knowledge Base and using e-support.
- Contact the APC by Schneider Electric Customer Support Center by telephone or e-mail.
 - Local, country specific centers: go to **www.apc.com/support/contact** for contact information.

For information on how to obtain local customer support, contact the APC by Schneider Electric representative or other distributor from whom you purchased your APC by Schneider Electric product.