



Questo manuale d'istruzione è fornito da trovaprezzi.it. Scopri tutte le offerte per [APC SURT48XLBP](#) o cerca il tuo prodotto tra le [migliori offerte di Gruppi di Continuità](#)

**APC**<sup>™</sup>  
by **Schneider** Electric

# Installation and Operation

## Smart-UPS<sup>™</sup> RT External Battery Pack

**SURT48XLBP**  
**Tower**

**Smart-UPS<sup>™</sup> RT**  
**External Battery Pack**  
**SURT48XLBP**

**English**

# 1: SAFETY INFORMATION

The APC™ by Schneider Electric Smart-UPS™ SURT192XLBP external battery pack (XLBP) connects to select APC by Schneider Electric Uninterruptible Power Supply (UPS) models. Together these units provide extended protection for electronic equipment from utility power blackouts, brownouts, sags, and surges. The UPS and the external battery pack together provide continuous power from the batteries until utility power returns to safe levels or the batteries are fully discharged.

The UPS and the XLBP are packaged separately.



**Changes or modifications to this unit not expressly approved by the party responsible for compliance could void the warranty.**

## HANDLING SAFETY

Be careful. Do not lift heavy loads without assistance.



<18 kg (<40 lb)



32–55 kg (70–120 lb)



18–32 kg (40–70 lb)



>55 kg (>120 lb)

This equipment is intended for installation in a temperature controlled indoor area free of conductive contaminants.

## BATTERY SAFETY



**This equipment contains potentially hazardous voltages that may cause personal injury if handled incorrectly.**

**This equipment must be installed and serviced only by qualified electrical service personnel.**

- This equipment contains potentially hazardous voltages. Do not attempt to disassemble the unit. The unit contains no user serviceable parts. Repairs are must performed only by factory trained service personnel.
- Do not dispose of batteries in a fire. The batteries may explode.
- Do not open or mutilate batteries. They contain an electrolyte that is toxic and harmful to the skin and eyes.
- Do not connect the terminals of a battery or battery pack with a wire or other electrically conductive objects.
- To avoid personal injury due to energy hazard, remove wrist watches and jewelry such as rings when replacing the batteries. Use tools with insulated handles.
- Replace batteries with the same number and type of batteries as originally installed in the equipment.

## BATTERY REPLACEMENT AND RECYCLING

See your dealer or visit the APC by Schneider Electric web site, [www.apc.com](http://www.apc.com) for information on replacement battery kits and battery recycling.



Be sure to return the spent battery to APC by Schneider Electric for recycling. Ship it to APC by Schneider Electric in the replacement battery packing material.

## 2: INSTALL THE BATTERY PACK

The APC by Schneider Electric Smart-UPS RT External Battery Pack provides extended protection to safeguard your computer and other valuable electronic equipment. The external battery pack also provides extra protection while replacing the batteries in the UPS.

### MAXIMUM NUMBER OF BATTERY PACKS SUPPORTED BY THE UPS

The Smart-UPS RT can support an unlimited number of external battery packs. Battery pack connectors are color-coded and keyed to prevent improper connection. Models SURT1000XLI and SURT2000XLI both use battery pack model SURT48XLBP. Both are designed to operate in the tower configuration and rack mount configuration.

### UNPACKING

1. Inspect the battery pack upon receipt. APC by Schneider Electric designed robust packaging for your product. However, accidents and damage may occur during shipment. Notify the carrier and dealer if there is damage.

The packaging is recyclable; save it for reuse or dispose of it properly.

2. Check the package contents. The shipping package contains the battery pack, its front bezel (packaged separately), mounting foot expansion piece, rear bracket tie, and a literature kit containing product documentation.

The battery pack is shipped with the front bezel removed (packaged separately within the main box). You will install the plastic bezel during the installation procedure.

### POSITIONING THE BATTERY PACK

Place the battery pack where it will be used. **The battery pack is heavy. Select a location sturdy enough to handle the weight.**

Consider that you must install the battery pack in a protected area that is free of excessive dust and has adequate airflow. Ensure the air vents on the front and rear of the battery pack are not blocked. Allow at least one inch of space on both sides.

Do not operate the UPS where the temperature and humidity are outside the specified limits. Refer to Specifications at the APC by Schneider Electric web site, [www.apc.com](http://www.apc.com).

#### PLACEMENT

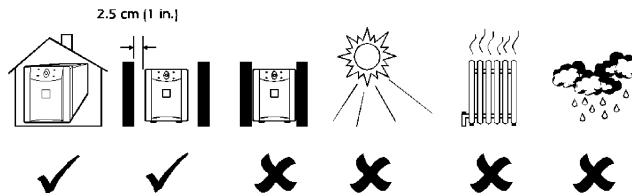

## REVIEWING CONNECTORS ON THE BATTERY PACK AND UPS

The UPS and battery pack(s) can be installed together in the tower configuration. The Front View shows what the units look like after installation. The Rear View shows the same units – the battery pack connection cable plug is not yet engaged in this view. Only one external battery pack is shown here.

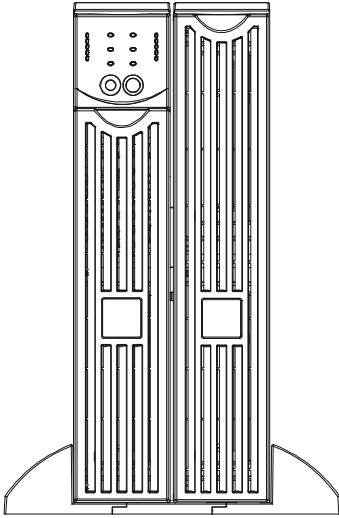

UPS Battery Pack  
**Front View**

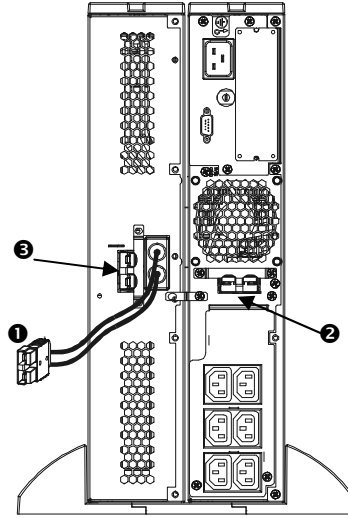

Battery Pack UPS  
**Rear View**

### **Connection Cable plug**

The connection cable plug **1** is to be attached into either a battery pack connector on the UPS **2**, or another battery pack if daisy chaining more than one battery pack together. The connector is color-coded and keyed to prevent improper connection.

### **Battery Pack Connector**

Use the battery pack connector **3** to daisy chain multiple battery packs to the same UPS. The connector is color coded and keyed to prevent improper connection.

## INSTALL THE BATTERY PACK

To install one or multiple battery packs in the tower configuration, follow these basic steps.

### **REMOVE AND EXPAND THE UPS FEET**

**The UPS is heavy.** Remove the battery tray to lighten it. Instructions to remove the battery tray and the feet can be found in your UPS User Manual.

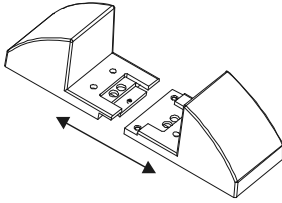

1. Once the feet have been removed, snap apart each foot into two end brackets.

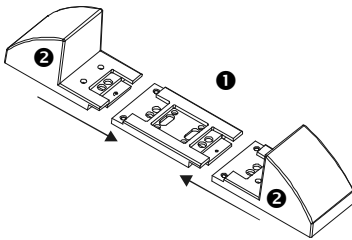

2. Each foot needs one expansion piece **1** for each external battery pack you are using. Additional expansion pieces are shipped with the external battery packs. Snap all center expansion pieces together, and then snap the brackets **2** back onto the ends of the expansion piece(s) to complete the foot. Repeat with the other foot.

## REMOVE THE BATTERY TRAYS FROM THE BATTERY PACK

The battery pack is heavy. To lighten it, remove the battery trays. Battery trays in your external battery pack are installed and removed just like the battery tray found in your UPS.

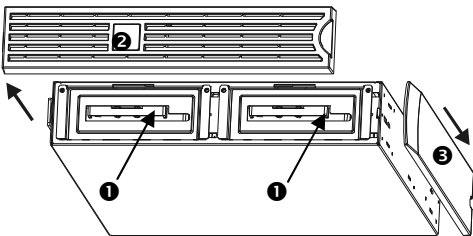

The battery trays are accessible from the front of the battery pack (shown at left). This procedure requires a Phillips screwdriver.

1. Notice that two battery tray compartments ❶ are visible. The External Battery Pack is shipped with the bezel ❷ removed, but the top decorative panel ❸ attached.
2. If your external battery pack has been in operation, you will need to remove the top decorative panel and front bezel before gaining access to the battery compartments. Remove them using instructions found in your UPS *User Manual*.
3. Continue following instructions in the UPS *User Manual* section *Remove and Reinstall Battery Pack* to remove the battery doors, disconnect batteries (if the battery pack has been in use; the batteries are shipped disconnected) and remove the battery trays.

## POSITION THE BATTERY PACK AND UPS



If more than 2 external battery packs are to be connected to the UPS, you will need more than one person to properly support and rotate the attached units during the installation, even after removal of all battery trays.

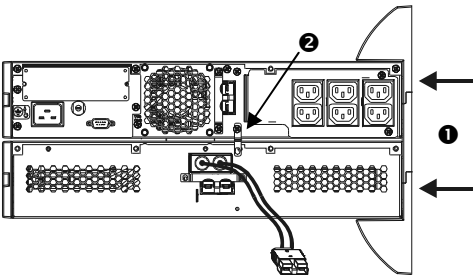

1. Position the UPS on the battery pack(s). Reattach the expanded feet ❶ according to the instructions in your UPS *User Manual*. Screw the feet firmly into both the UPS and each battery pack.
2. Screw the rear bracket tie(s) ❷ in place between the external battery pack and the UPS, and between each external battery pack if you are daisy chaining more than one battery pack to your UPS.
3. Carefully rotate the whole attached unit upright onto the feet.
4. Reinstall the battery trays into the UPS and battery packs. Be certain to connect the batteries. Reattach the front bezels and top cover panels. Instructions for these steps can be found in your UPS *User Manual*.

## CONNECT THE BATTERY PACK TO THE UPS



Battery pack connectors are color-coded and keyed to prevent improper connection. The color of the connector on the UPS must match the color of the battery pack connector.



Allow the battery pack to charge for 24 hours. *Do not* expect full run time during this initial charge period.

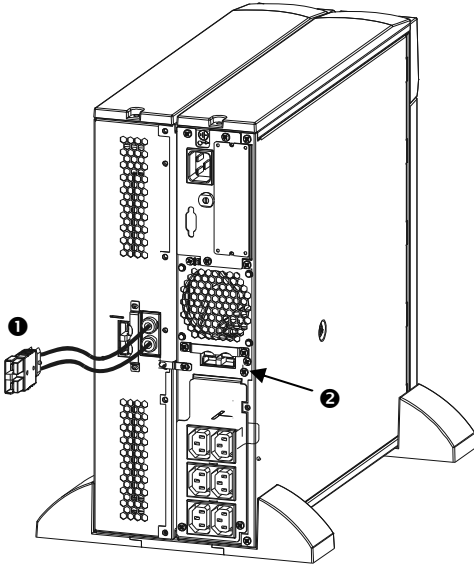

1. Insert the battery pack connector plug **1** into the rear connector **2** on the back of the UPS.

## CONNECT A BATTERY PACK TO ANOTHER BATTERY PACK

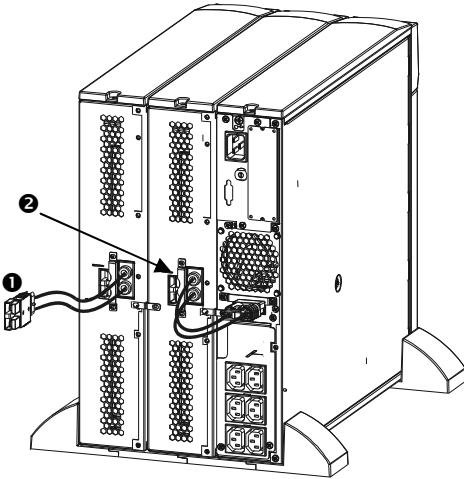

1. Insert the battery pack connector cable plug ❶ into the rear connector ❷ on the back of the other battery pack. Note that the illustration at left shows the UPS and the first external battery pack properly connected.

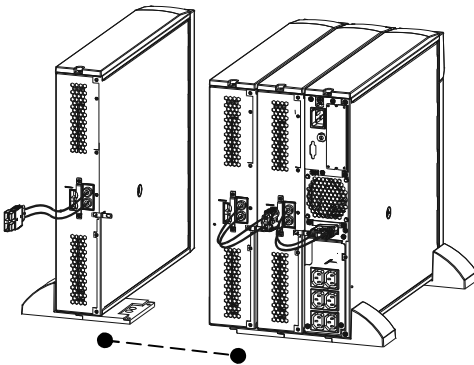

An unlimited number of external battery packs can be attached and daisy chained together in this fashion.

## MOUNT THE BATTERY PACK IN A RACK

To install one or multiple battery packs into a rack mount, you need to obtain a *Rail Kit* (Part # SURTRK). The *Rail Kit* to mount a Smart-UPS RT UPS and External Battery Pack is the same. Mount your external battery pack exactly as you would a UPS, except the battery pack will have two battery trays to remove and replace instead of one. There is no control panel on the external battery pack to rotate.

### 3: OPERATING THE SMART-UPS RT WITH A BATTERY PACK

#### SETT THE SMART-UPS RT TO RECOGNIZE THE BATTERY PACK(S)

Smart-UPS RT models cannot determine how many external battery packs are connected to them. You must program the Smart-UPS RT with the appropriate number of external batteries in one of two ways by using:

- PowerChute™ *plus* Version 5.x for Windows 95, Windows 98, or Windows NT
- A terminal program to change the number of external battery packs

Each method is described in this section.



It is important to follow these instructions. The number of batteries affects the run time calculations the Smart-UPS RT performs when it is running on battery power.

#### **USING POWERCHUTE PLUS VERSION 5.X FOR WINDOWS 95, WINDOWS 98, WINDOWS NT**

PowerChute *plus* 5.x for Windows NT is compatible with NT 3.5.1 SP5, NT 4.0 Workstation (at least SP1), or NT 4.0 Server (at least SP1).

1. Install the software per the instructions on the CD. After rebooting the computer, access the PowerChute *plus* graphical user interface.
2. Click on **Configuration**.
3. Click on **UPS Operating Parameters**.
4. Adjust the **External Battery Pack** field to the appropriate number of external battery packs.
5. Click **OK**.

#### **USING A TERMINAL PROGRAM TO CHANGE THE NUMBER OF EXTERNAL BATTERY PACKS**

1. **EXIT** the PowerChute *plus* Server if running. In Windows NT, the UPS Service must be stopped.
2. Open a terminal program. For example to open Hyperterminal in Windows NT:

From the Desktop, go to **Start => Programs => Accessories => Hyperterminal**. Double click on the **Hyperterminal** icon. You are prompted to choose a name and select an icon. Enter name and then click **OK**. Disregard the message, "...must install a modem," if it is displayed.

3. Select the COM port. The port settings are 2400 baud, 8 data bits, 1 stop bit, no parity, flow control off.
4. Once the terminal window is open, follow these steps to enter the number of external battery packs using the terminal mode within the Smart-UPS RT:

Hit the Enter key to initiate terminal mode. Following the prompts:

Hit 1 to modify UPS Settings. Hit e (or E) to modify the number of external battery packs. Enter the number of external battery packs only (don't count the internal battery pack) followed by the Enter key. Enter YES (must be upper case) followed by the Enter key to confirm the new setting. Hit any key to continue. Hit the Esc key to return to the main menu. Hit the Esc key again to logout of terminal mode.

5. Exit the terminal program.
6. Restart the PowerChute *plus* Server if desired. In Windows NT, the UPS Service must be restarted if desired.

## 4: STORAGE AND MAINTENANCE

### STORAGE

#### **STORAGE CONDITIONS**

Store the battery pack covered and flat (rack mount orientation) in a cool, dry location, with its battery fully charged. Disconnect battery cables to avoid drain on batteries.

#### **EXTENDED STORAGE**

At  $-15^{\circ}$  to  $+30^{\circ}$  C ( $+5^{\circ}$  to  $+86^{\circ}$  F), charge the batteries every six months.

At  $+30^{\circ}$  to  $+45^{\circ}$  C ( $+86^{\circ}$  to  $+113^{\circ}$  F), charge the batteries every three months.

### REPLACE A BATTERY TRAY

The battery pack has two easy to replace, hot-swappable battery trays. Battery tray replacement is a safe procedure, isolated from electrical hazards. You may leave the battery pack connected to the UPS with the protected equipment when replacing battery trays. See the APC by Schneider Electric web site, [www.apc.com](http://www.apc.com) to confirm the correct replacement battery tray number (RBC) and to see other options. Follow the instructions in your UPS *User Manual* and in this manual in the *Installation* section.

## 4: SERVICE, TRANSPORT AND WARRANTY

### TRANSPORT

1. Shut down and disconnect all connected equipment.
2. Disconnect the unit from utility power.
3. Disconnect all internal and external batteries (if applicable).
4. Follow the shipping instructions outlined in the *Service* section of this manual.

### SERVICE

If the unit requires service, do not return it to the dealer. Follow these steps:

1. Review the *Troubleshooting* section of the manual to eliminate common problems.
2. If the problem persists, contact APC by Schneider Electric Customer Support through the APC by Schneider Electric web site, **www.apc.com**.
  - a. Note the model number and serial number and the date of purchase. The model and serial numbers are located on the rear panel of the unit and are available through the LCD display on select models.
  - b. Call Customer Support and a technician will attempt to solve the problem over the phone. If this is not possible, the technician will issue a Returned Material Authorization Number (RMA#).
  - c. If the unit is under warranty, the repairs are free.
  - d. Service procedures and returns may vary internationally. Refer to the APC by Schneider Electric web site, **www.apc.com** for country specific instructions.
3. Pack the unit properly to avoid damage in transit. Never use foam beads for packaging. Damage sustained in transit is not covered under warranty.
  - a. **Note: When shipping within the United States, or to the United States always DISCONNECT ONE UPS BATTERY before shipping in compliance with U.S. Department of Transportation (DOT) and IATA regulations.** The internal batteries may remain in the UPS.
  - b. Batteries may remain connected in the XBP during shipment. Not all units utilize XLBPs.
4. Write the RMA# provided by Customer Support on the outside of the package.
5. Return the unit by insured, prepaid carrier to the address provided by Customer Support.

## LIMITED FACTORY WARRANTY

Schneider Electric IT Corporation (SEIT), warrants its products to be free from defects in materials and workmanship for a period of two (2) years from the date of purchase. The SEIT obligation under this warranty is limited to repairing or replacing, at its own sole option, any such defective products. Repair or replacement of a defective product or parts thereof does not extend the original warranty period.

This warranty applies only to the original purchaser who must have properly registered the product within 10 days of purchase. Products may be registered online at [warranty.apc.com](http://warranty.apc.com).

SEIT shall not be liable under the warranty if its testing and examination disclose that the alleged defect in the product does not exist or was caused by end user or any third person misuse, negligence, improper installation, testing, operation or use of the product contrary to SEIT recommendations or specifications. Further, SEIT shall not be liable for defects resulting from: 1) unauthorized attempts to repair or modify the product, 2) incorrect or inadequate electrical voltage or connection, 3) inappropriate on site operation conditions, 4) Acts of God, 5) exposure to the elements, or 6) theft. In no event shall SEIT have any liability under this warranty for any product where the serial number has been altered, defaced, or removed.

**EXCEPT AS SET FORTH ABOVE, THERE ARE NO WARRANTIES, EXPRESS OR IMPLIED, BY OPERATION OF LAW OR OTHERWISE, APPLICABLE TO PRODUCTS SOLD, SERVICED OR FURNISHED UNDER THIS AGREEMENT OR IN CONNECTION HERewith. SEIT DISCLAIMS ALL IMPLIED WARRANTIES OF MERCHANTABILITY, SATISFACTION AND FITNESS FOR A PARTICULAR PURPOSE. SEIT EXPRESS WARRANTIES WILL NOT BE ENLARGED, DIMINISHED, OR AFFECTED BY AND NO OBLIGATION OR LIABILITY WILL ARISE OUT OF, SEIT RENDERING OF TECHNICAL OR OTHER ADVICE OR SERVICE IN CONNECTION WITH THE PRODUCTS. THE FOREGOING WARRANTIES AND REMEDIES ARE EXCLUSIVE AND IN LIEU OF ALL OTHER WARRANTIES AND REMEDIES. THE WARRANTIES SET FORTH ABOVE CONSTITUTE SEIT SOLE LIABILITY AND PURCHASER EXCLUSIVE REMEDY FOR ANY BREACH OF SUCH WARRANTIES. SEIT WARRANTIES EXTEND ONLY TO ORIGINAL PURCHASER AND ARE NOT EXTENDED TO ANY THIRD PARTIES. IN NO EVENT SHALL SEIT, ITS OFFICERS, DIRECTORS, AFFILIATES OR EMPLOYEES BE LIABLE FOR ANY FORM OF INDIRECT, SPECIAL, CONSEQUENTIAL OR PUNITIVE DAMAGES, ARISING OUT OF THE USE, SERVICE OR INSTALLATION OF THE PRODUCTS, WHETHER SUCH DAMAGES ARISE IN CONTRACT OR TORT, IRRESPECTIVE OF FAULT, NEGLIGENCE OR STRICT LIABILITY OR WHETHER SEIT HAS BEEN ADVISED IN ADVANCE OF THE POSSIBILITY OF SUCH DAMAGES. SPECIFICALLY, SEIT IS NOT LIABLE FOR ANY COSTS, SUCH AS LOST PROFITS OR REVENUE, WHETHER DIRECT OR INDIRECT, LOSS OF EQUIPMENT, LOSS OF USE OF EQUIPMENT, LOSS OF SOFTWARE, LOSS OF DATA, COSTS OF SUBSTITUANTS, CLAIMS BY THIRD PARTIES, OR OTHERWISE. NOTHING IN THIS LIMITED WARRANTY SHALL SEEK TO EXCLUDE OR LIMIT SEIT LIABILITY FOR DEATH OR PERSONAL INJURY RESULTING FROM ITS NEGLIGENCE OR ITS FRAUDULENT MISREPRESENTATION OF TO THE EXTENT THAT IT CANNOT BE EXCLUDED OR LIMITED BY APPLICABLE LAW.**

To obtain service under warranty you must obtain a Returned Material Authorization (RMA) number from customer support. Customers with warranty claims issues may access the SEIT worldwide customer support network through the APC web site: [www.apc.com](http://www.apc.com). Select your country from the country selection drop down menu. Open the Support tab at the top of the web page to obtain information for customer support in your region. Products must be returned with transportation charges prepaid and must be accompanied by a brief description of the problem encountered and proof of date and place of purchase.



# APC by Schneider Electric Worldwide Customer Support

Customer support for this or any other APC by Schneider Electric product is available at no charge in any of the following ways:

- Visit the APC by Schneider Electric web site, [www.apc.com](http://www.apc.com) to access documents in the APC Knowledge Base and to submit customer support requests.
  - **www.apc.com** (Corporate Headquarters)  
Connect to localized APC by Schneider Electric web site for specific countries, each of which provides customer support information.
  - **www.apc.com/support/**  
Global support searching APC Knowledge Base and using e-support.
- Contact the APC by Schneider Electric Customer Support Center by telephone or e-mail.
  - Local, country specific centers: go to **www.apc.com/support/contact** for contact information.
  - For information on how to obtain local customer support, contact the APC by Schneider Electric representative or other distributor from whom you purchased your APC by Schneider Electric product.

© 2014 APC by Schneider Electric. Smart-UPS and PowerChute are owned by Schneider Electric Industries S.A.S. or their affiliated companies. All other trademarks are property of their respective owners.