

ROG STRIX HELIOS

User Manual

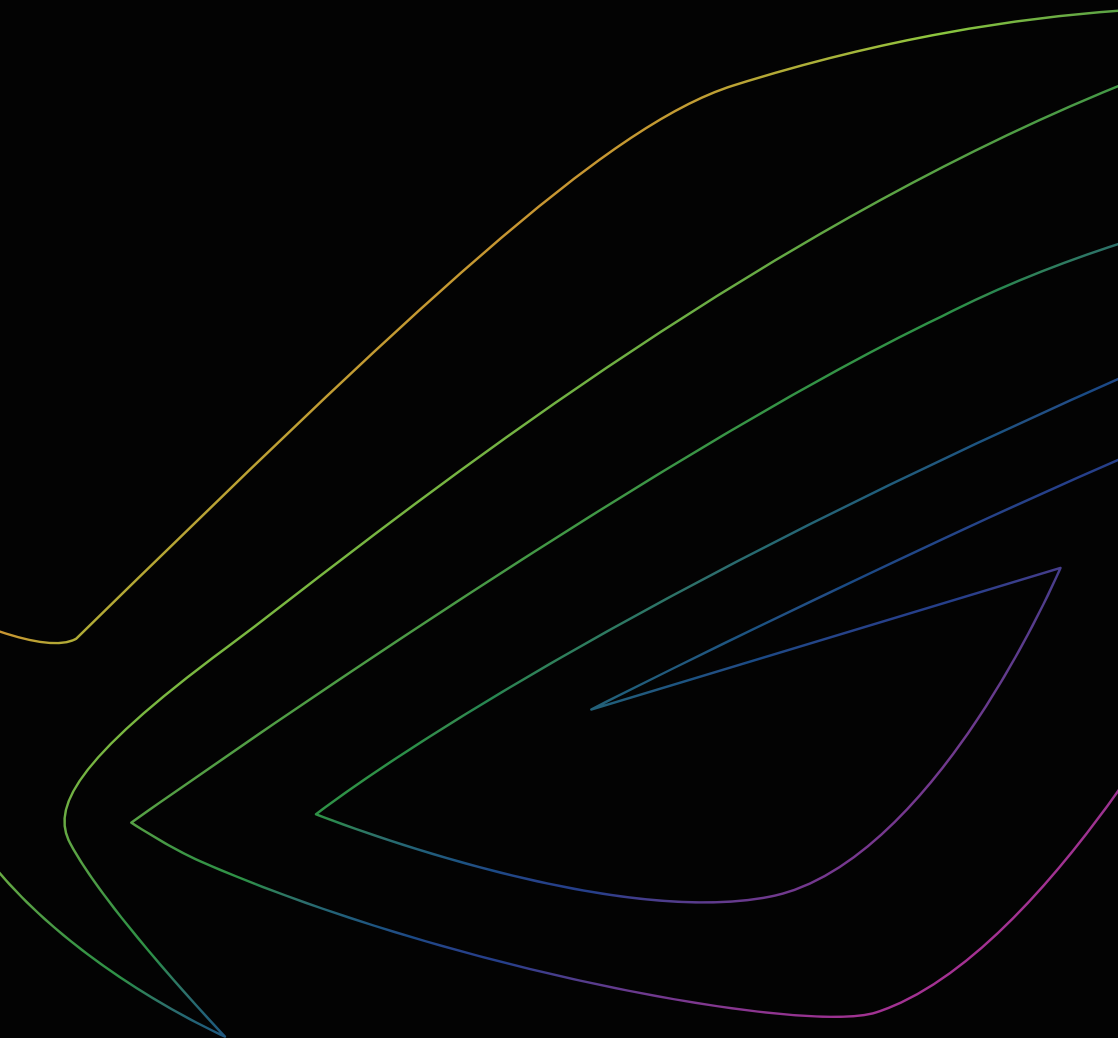

**Copyright © 2019 ASUSTeK Computer Inc.
All Rights Reserved.**

No part of this manual, including the products and software described in it, may be reproduced, transmitted, transcribed, stored in a retrieval system, or translated into any language in any form or by any means, except documentation kept by the purchaser for backup purposes, without the express written permission of ASUSTek Computer Inc. ("ASUS").

Product warranty or service will not be extended if: (1) the product is repaired, modified or altered, unless such repair, modification or alteration is authorized in writing by ASUS; or (2) the serial number of the product is defaced or missing.

ASUS PROVIDES THIS MANUAL "AS IS" WITHOUT WARRANTY OF ANY KIND, EITHER EXPRESS OR IMPLIED, INCLUDING BUT NOT LIMITED TO THE IMPLIED WARRANTIES OR CONDITIONS OF MERCHANTABILITY OR FITNESS FOR A PARTICULAR PURPOSE. IN NO EVENT SHALL ASUS, ITS DIRECTORS, OFFICERS, EMPLOYEES OR AGENTS BE LIABLE FOR ANY INDIRECT, SPECIAL, INCIDENTAL, OR CONSEQUENTIAL DAMAGES (INCLUDING DAMAGES FOR LOSS OF PROFITS, LOSS OF BUSINESS, LOSS OF USE OR DATA, INTERRUPTION OF BUSINESS AND THE LIKE), EVEN IF ASUS HAS BEEN ADVISED OF THE POSSIBILITY OF SUCH DAMAGES ARISING FROM ANY DEFECT OR ERROR IN THIS MANUAL OR PRODUCT.

SPECIFICATIONS AND INFORMATION CONTAINED IN THIS MANUAL ARE FURNISHED FOR INFORMATIONAL USE ONLY, AND ARE SUBJECT TO CHANGE AT ANY TIME WITHOUT NOTICE, AND SHOULD NOT BE CONSTRUED AS A COMMITMENT BY ASUS. ASUS ASSUMES NO RESPONSIBILITY OR LIABILITY FOR ANY ERRORS OR INACCURACIES THAT MAY APPEAR IN THIS MANUAL, INCLUDING THE PRODUCTS AND SOFTWARE DESCRIBED IN IT.

Products and corporate names appearing in this manual may or may not be registered trademarks or copyrights of their respective companies, and are used only for identification or explanation and to the owners' benefit, without intent to infringe.

CONTENTS

ACCESSORY KIT CONTENTS INSTALLATION GUIDE

| | |
|---|----|
| Remove the Side Panels | 2 |
| Remove the PSU Cover | 3 |
| Multi Function Cover | 4 |
| Install the Power Supply Unit (PSU) | 5 |
| Install the Cooler & RAM on the Motherboard | 7 |
| Install the I/O Shield | 8 |
| Install the Motherboard Unit | 9 |
| Attach the Front I/O Connectors | 10 |
| Sync Case Lighting With Addressable RGB Compatible Motherboards | 11 |
| Fan Hub Connectivity | 12 |
| Install the PCI-E Card | 14 |
| Install the 2.5" Drives | 16 |
| Install the 3.5"/2.5" Drives | 17 |
| Installation and Maintenance of the Dust Filters | 18 |
| Pump Installation | 19 |

ADDITIONAL INFORMATION

| | |
|-----------------------------------|----|
| CPU Cooler Height Limitation | 21 |
| Graphics Card Limitations | 22 |
| Graphics Card Placement Options | 23 |
| Fan Setup Compatibility | 24 |
| Water-cooling Radiator Options | 25 |
| Water-cooling Setup Compatibility | 26 |
| Recommended Handle Configuration | 28 |

OPTIONAL UPGRADES SAFETY INFORMATION

| |
|----|
| 33 |
| 35 |

ACCESSORY KIT CONTENTS

配備零組件內容物 | 配備組件內容物 | Obsah sady příslušenství | Contenu du kit d'accessoires | 액세서리
Verpackungsinhalt des Zubehörsatzes | Accessori contenuti nel kit | アクセサリーキットの内容 | 액세서리
키트 내용물 | Zawartość zestawu akcesoriów | Conteúdo do kit de acessórios | Содержимое комплекта |
Contenido del kit de accesorios | محتويات طقم الملحقات | Aksesuar Kitinin İçindekiler | Obsah súpravy s
príslušenstvom

A



Vertical GPU Kit x1

B



Pump Bracket Captive Thumb Screws x1
(Note: the pump bracket screw is included on the pump bracket)

C



Motherboard / 2.5" Drive Screws x40

D



PSU Screws x4

E



Standoff Tool x1

F



Motherboard Standoffs x3

G



Cable Ties x10

H



USB Type A(3.0) Dust Cover x2

I



USB Type C(3.1) Dust Cover x1

J



INSTALLATION GUIDE



安装指南 | 安裝指南 | Instalační příručka | Guide d'installation | Installationsanleitung | Guida all'installazione |
組み立てガイド | 설치 설명서 | Instrukcja instalacji | Manual de instalação | Руководство по установке | Guía de
instalación | Installationsguide | Kurulum Kılavuzu | Návod na inštaláciu | دليل التركيب

REMOVE THE SIDE PANELS

移除側面板 | 移除側面板 | Sejměte boční panely | Retirer les panneaux latéraux | Entfernen der Seitenwände
| Rimuovete i pannelli laterali | サイドパネルを取り外す | 측면 패널 제거 | Zdejmij panele boczne |
Remover os painéis laterais | Снимите боковые панели | Quite los paneles laterales |
Ta bort sidopanelerna | Yan Panelleri Çıkarın | Demontáž bočných panelov |
أزل اللوحات الجانبية

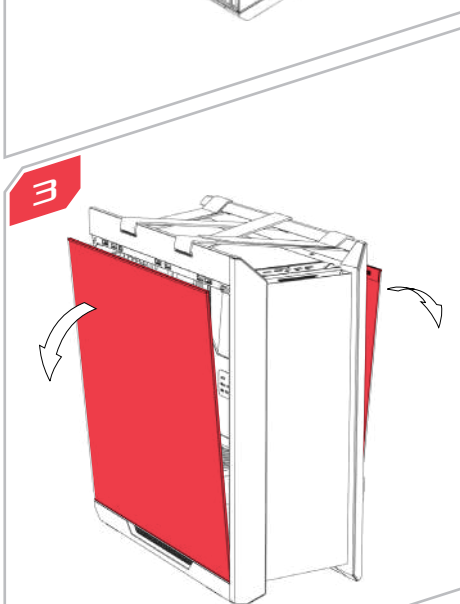
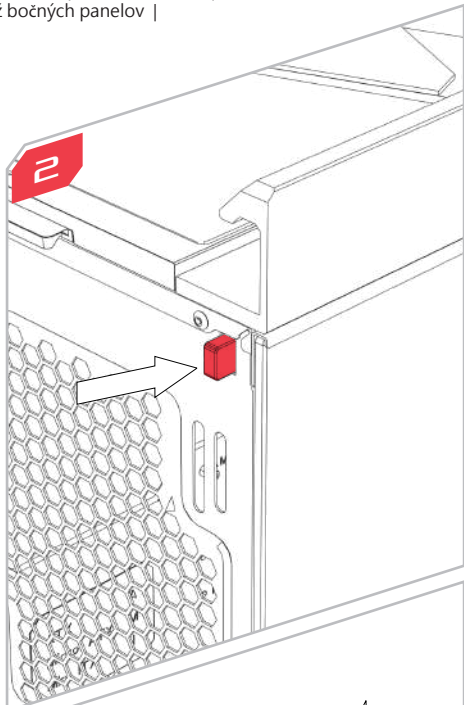
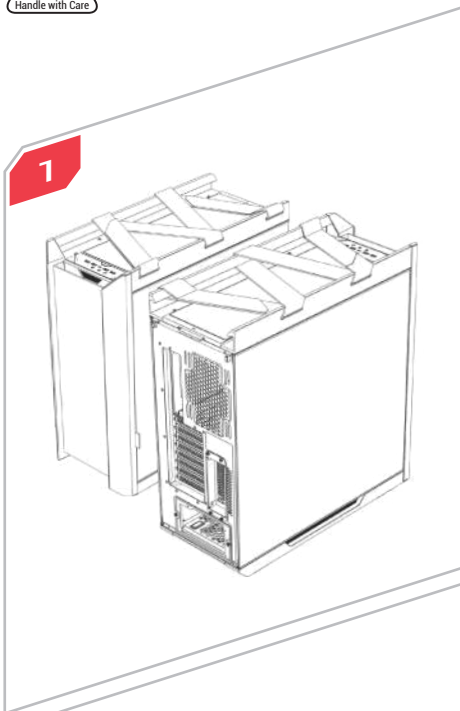

REMOVE THE PSU COVER

移除電源遮板 | 移除电源盖板 | Sejměte kryt PSU | Retirer le couvercle du bloc d'alimentation | Entfernen der Netzteilabdeckung | Rimuovete la cover dell'alimentatore | 電源装置カバーを取り外す | PSU 커버 제거 | Zdejmij pokrywę PSU | Remover a tampa da fonte de alimentação | Снимите крышку блока питания | Retirar la tapa de la fuente de alimentación | Ta bort PSU-skyddet | PSU Kapağını Çıkarın | Demontáž krytu PSU | أزل غطاء وحدة الإمداد بالطاقة

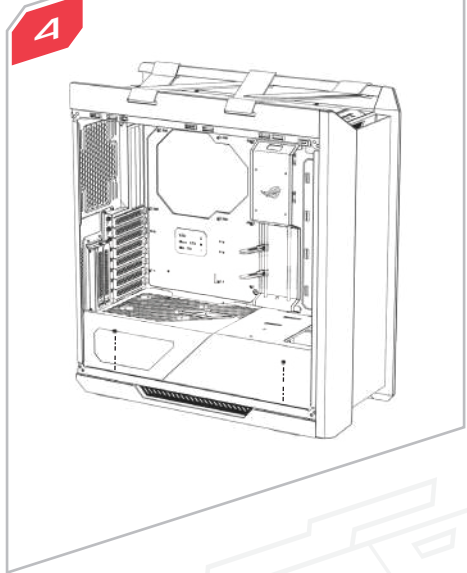
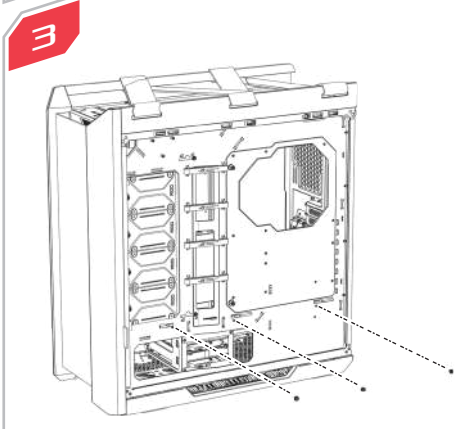
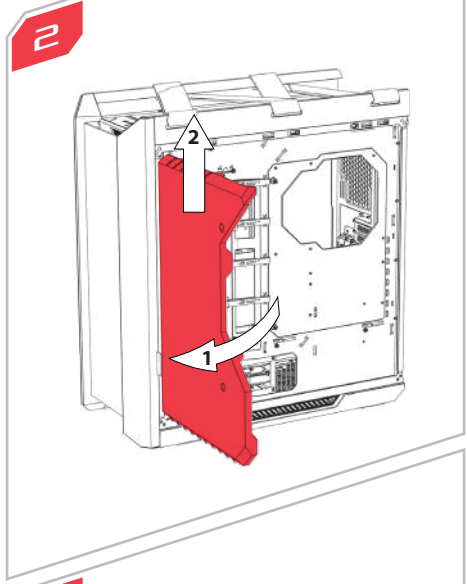
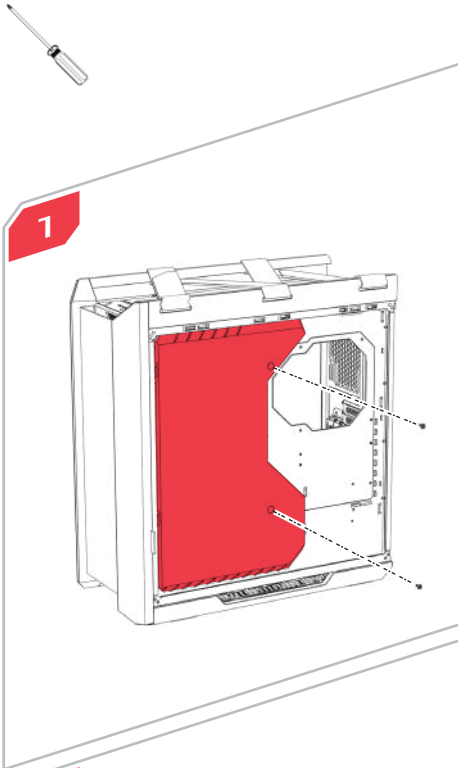

5

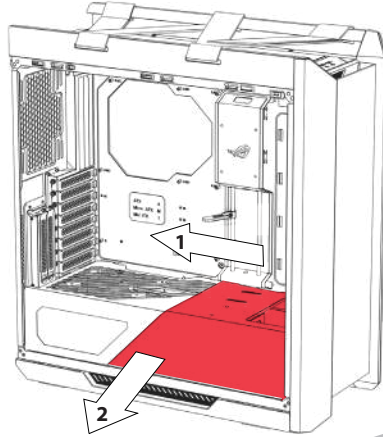

6

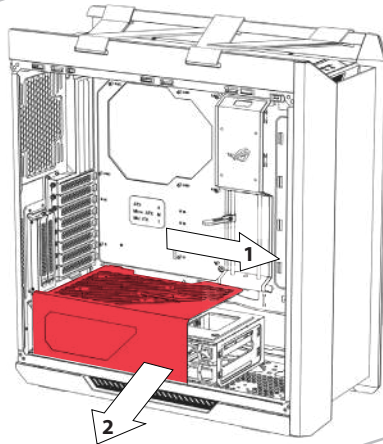

MULTI FUNCTION COVER

多功能遮蓋板 | 多功能盖板 | Multifunkční kryt | Couverture multifonction | Multifunktionsabdeckung |
Cover multifunzione | マルチファンクションカバー | 다기능 커버 | Pokrywa wielofunkcyjna |
Tampa multifunções | Многофункциональная крышка | Cubierta multifunción |
Multifunktionshölje | Çok İşlevli Kapak | Viacúčelový kryt | غطاء متعدد الوظائف

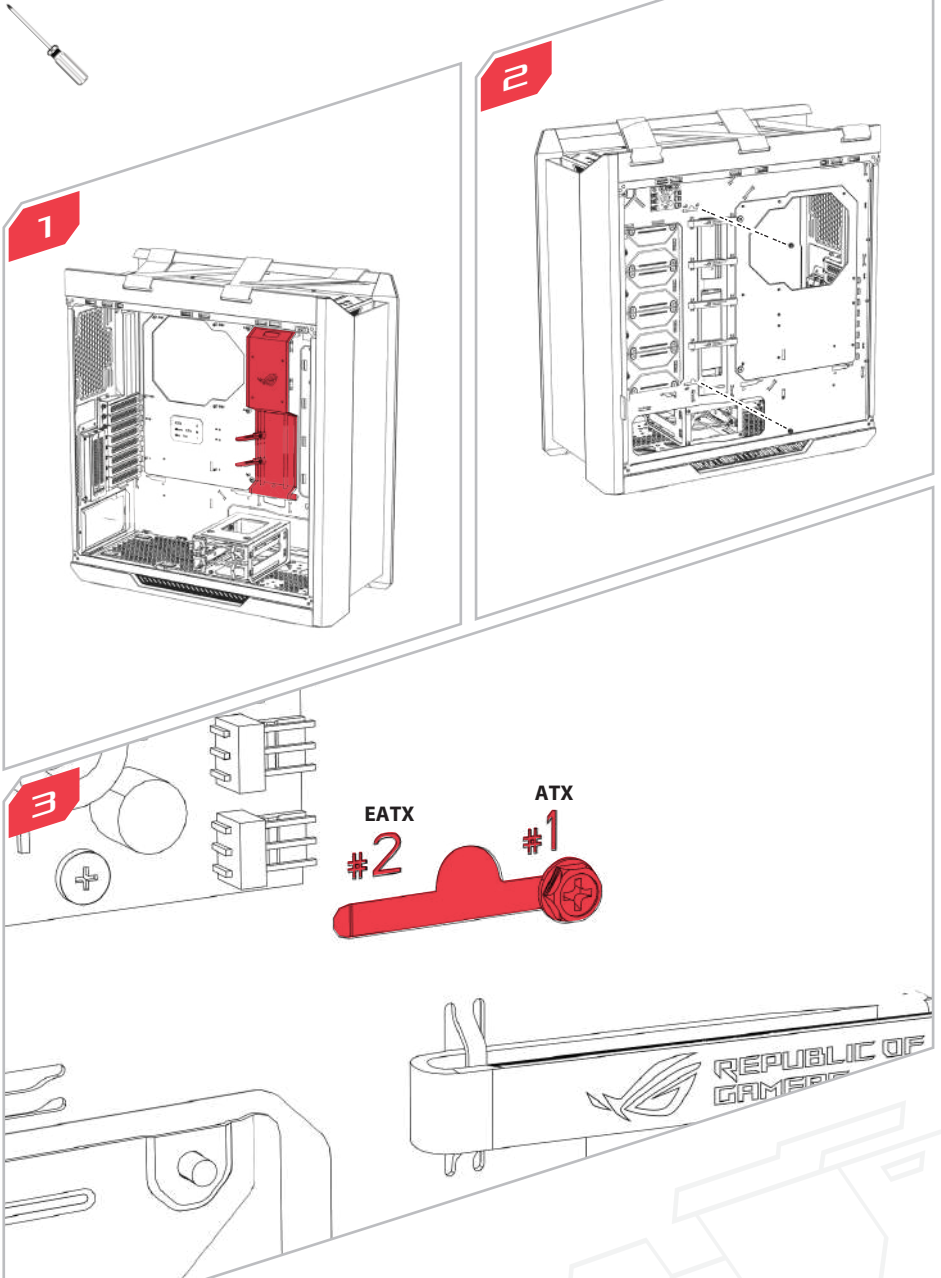

4

Adjustable

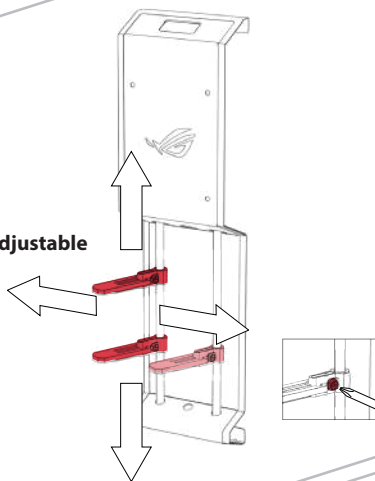

5

Adjustable

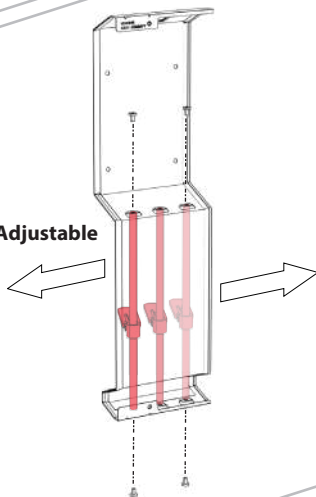

INSTALL THE POWER SUPPLY UNIT (PSU)

安裝電源供應器 | 安裝電源供應器 | Nainstalujte zdroj napájení (PSU) | Installer le bloc d'alimentation | Installation des Netzteils | Installate l'alimentatore (PSU) | 電源装置を取り付ける | 전원 공급장치(PSU) 설치 | Zainstaluj zasilacz (PSU) | Instalar a fonte de alimentação (PSU) | Установите блок питания | Instalar la fuente de alimentación (PSU) | Sätt i strömförsörjningsheten (PSU) | Güç Kaynağı Ünitesini (PSU) Takın | Inštalácia napájacej jednotky (PSU) | (PSU) وحدة الإمداد بالطاقة

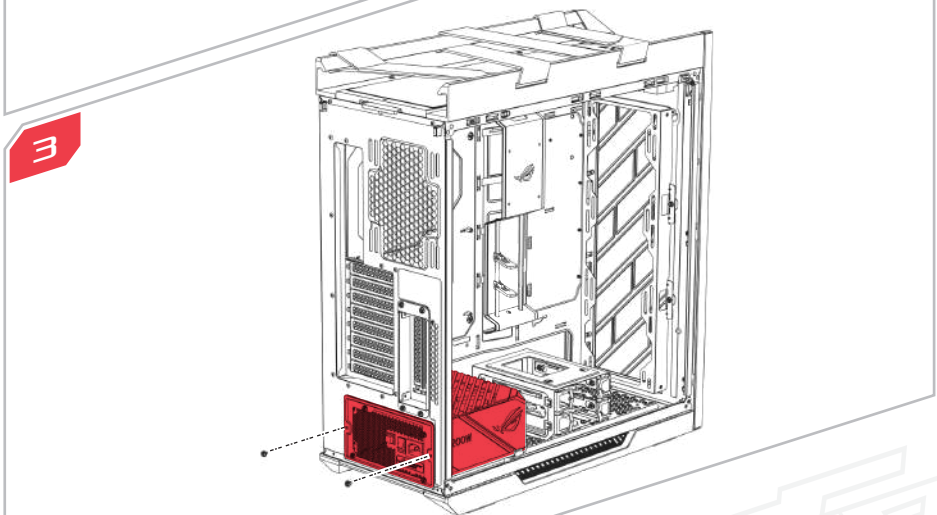
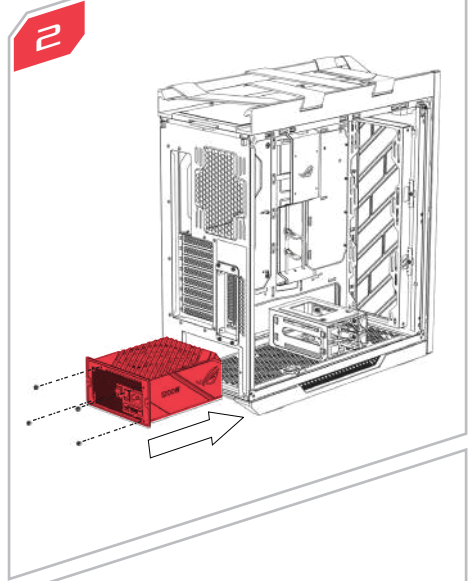
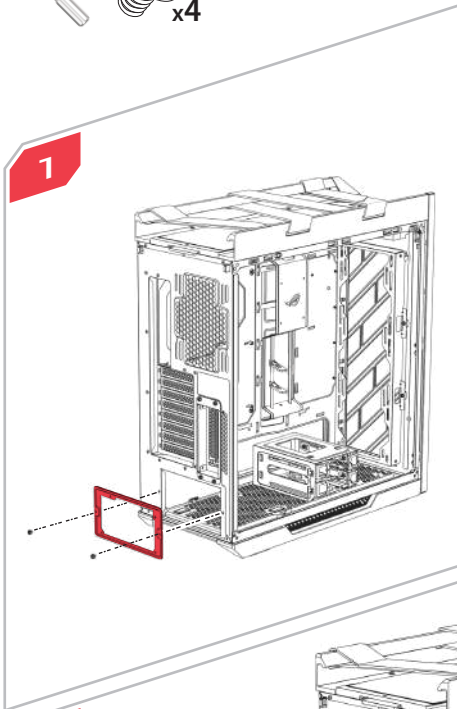

INSTALL THE COOLER & RAM ON THE MOTHERBOARD

安裝主機板散熱器和記憶體 | 安裝主板散熱器和內存卡 | Nainstalujte chladič a paměť RAM na základní desku | Installer le refroidisseur et la mémoire RAM sur la carte mère | Installation des Kühlers und der RAM-Module auf das Motherboard | Installate dissipatore e RAM sulla scheda madre | CPU、クーラー、メモリーをマザーボードに取り付ける | 메인보드에 쿨러 및 RAM 설치 | Zainstaluj element chłodzący i pamięć RAM na płycie głównej | Instalar o dissipador e memória RAM na placa principal | Установите на материнскую плату кулер и память | Instalar el refrigerador y la memoria RAM en la placa base | Montera kylare och RAM på moderkortet | Soğutucu ve RAM'i Anakarta Takın | Inštalácia chladiča a RAM na základnú dosku | باللوحة الأم (RAM)

رغب المبرد وذاكرة الوصول العشوائي

1

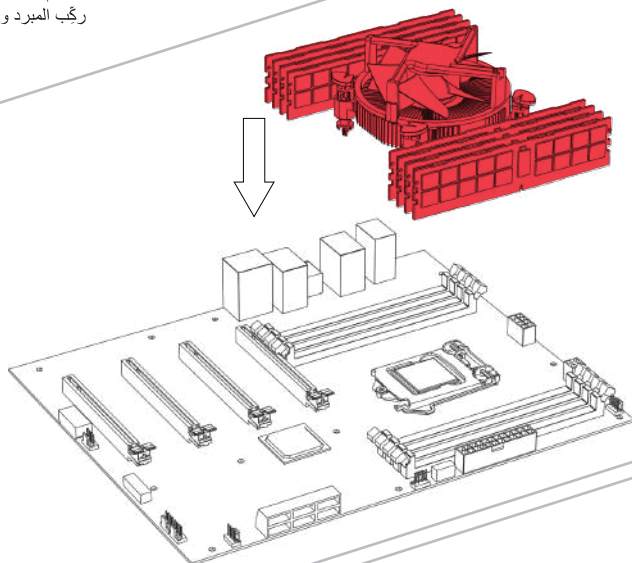

2

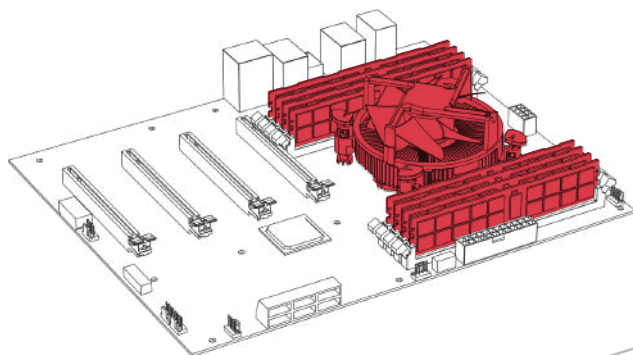

INSTALL THE I/O SHIELD

安装 I/O 挡板 | 安装 I/O 挡板 | Nainstalujte I/O štít | Installer le cache d'E/S | Installation der E/A-Blende | Installate la mascherina I/O | I/Oシールドを取り付ける | I/O 윌드 설치 | Zainstaluj osłonę portów We/Wy | Instalar a tampa de E/S | Установите заглушку разъемов ввода-вывода | Instalar la protección de E/S / Installera I/O-skölden | G/Ç Korumucuyu Takin | Inštalácia tienenia vstupov/výstupov | ركب غطاء الإدخال/الإخراج

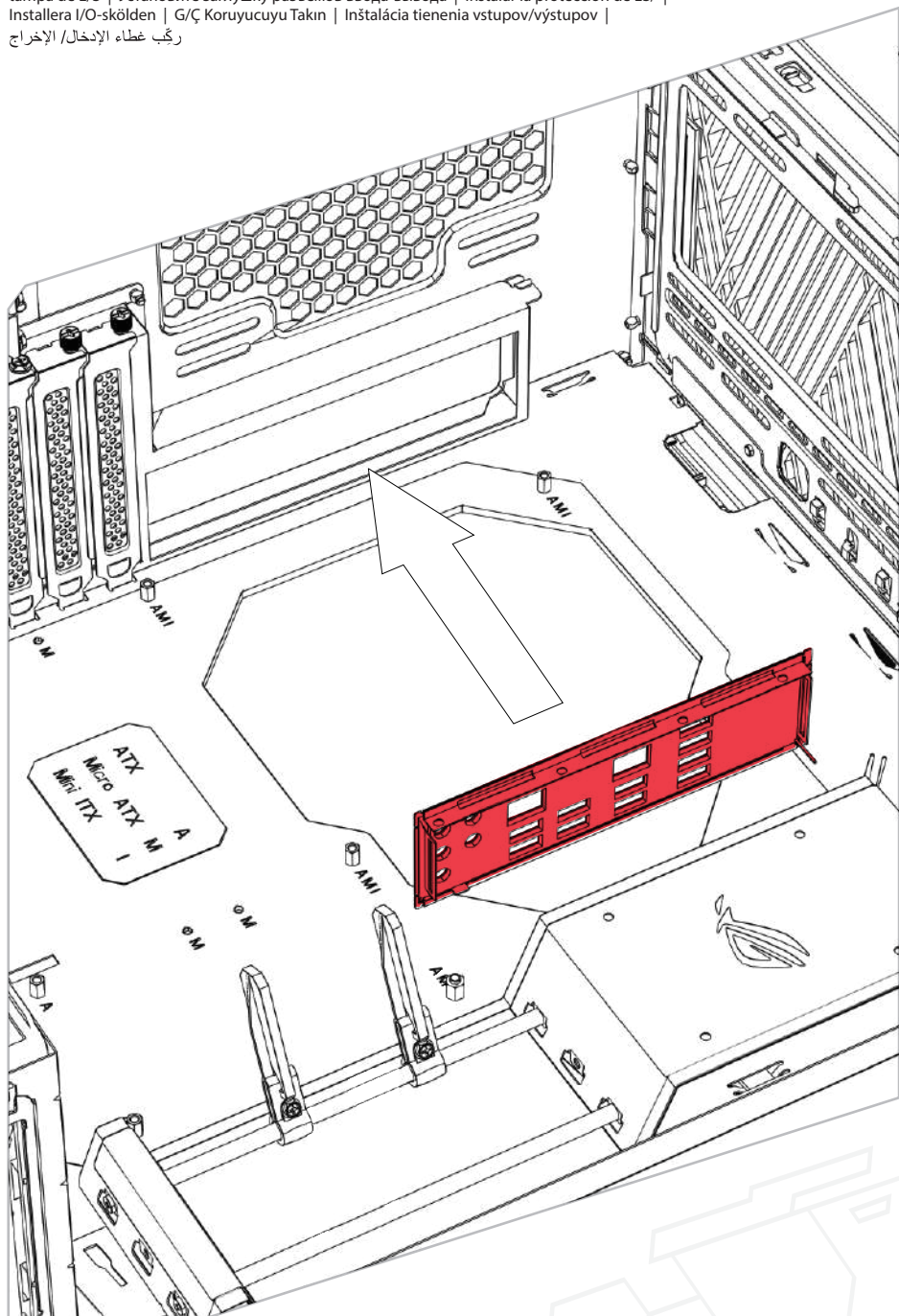

INSTALL THE MOTHERBOARD UNIT

將主機板裝入機殼 | 將主板裝入机箱 | Nainstalujte základní desku | Installer la carte mère | Installation der Motherboard-Baugruppe | Installate la scheda madre | マザーボードを取り付ける | 메인보드 유닛 설치 | Zainstaluj płytę główną | Instalar a placa principal | Установите материнскую плату | Instalar la unidad de la placa base | Installera moderkortsenheten | Anakart Ünitesini Takın | Inštalácia jednotky základnej dosky | ركب وحدة اللوحة الأم



1

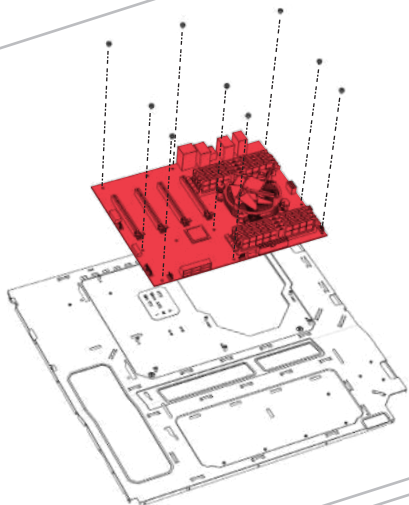

2

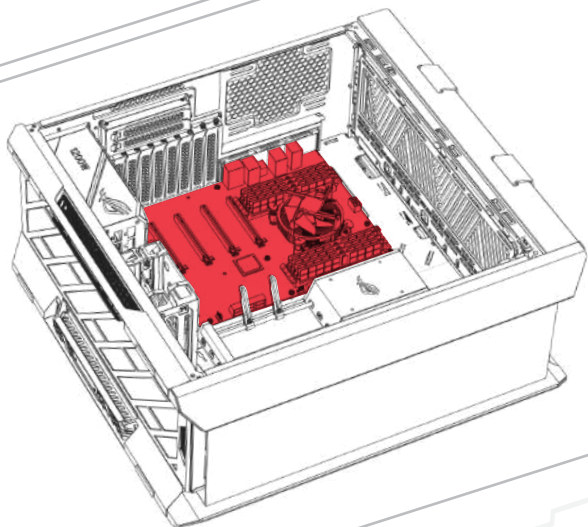

ATTACH THE FRONT I/O CONNECTORS

連接前面板 I/O 插孔 | 连接前面板 I/O 插孔 | Připojte přední I/O konektory | Fixer les connecteurs d'E/S avants | Befestigen der vorderen E/A-Anschlüsse | Collegare i connettori di I/O frontali | フロントI/Oコネクターを取り付ける | 전면 I/O 커넥터 연결 | Zamocuj przednie złącza We/Wy | Encaixar os conectores de E/S frontais | Подключите разъемы для передней панели | Acoplar los conectores de E/S frontales | Anslut de främre I/O-kontakterna | Ön G/Ç Konektörlerini Takın | Pripojenie predných vstupných/výstupných konektorov | وصّل موصلات الإدخال/الإخراج الأمامية

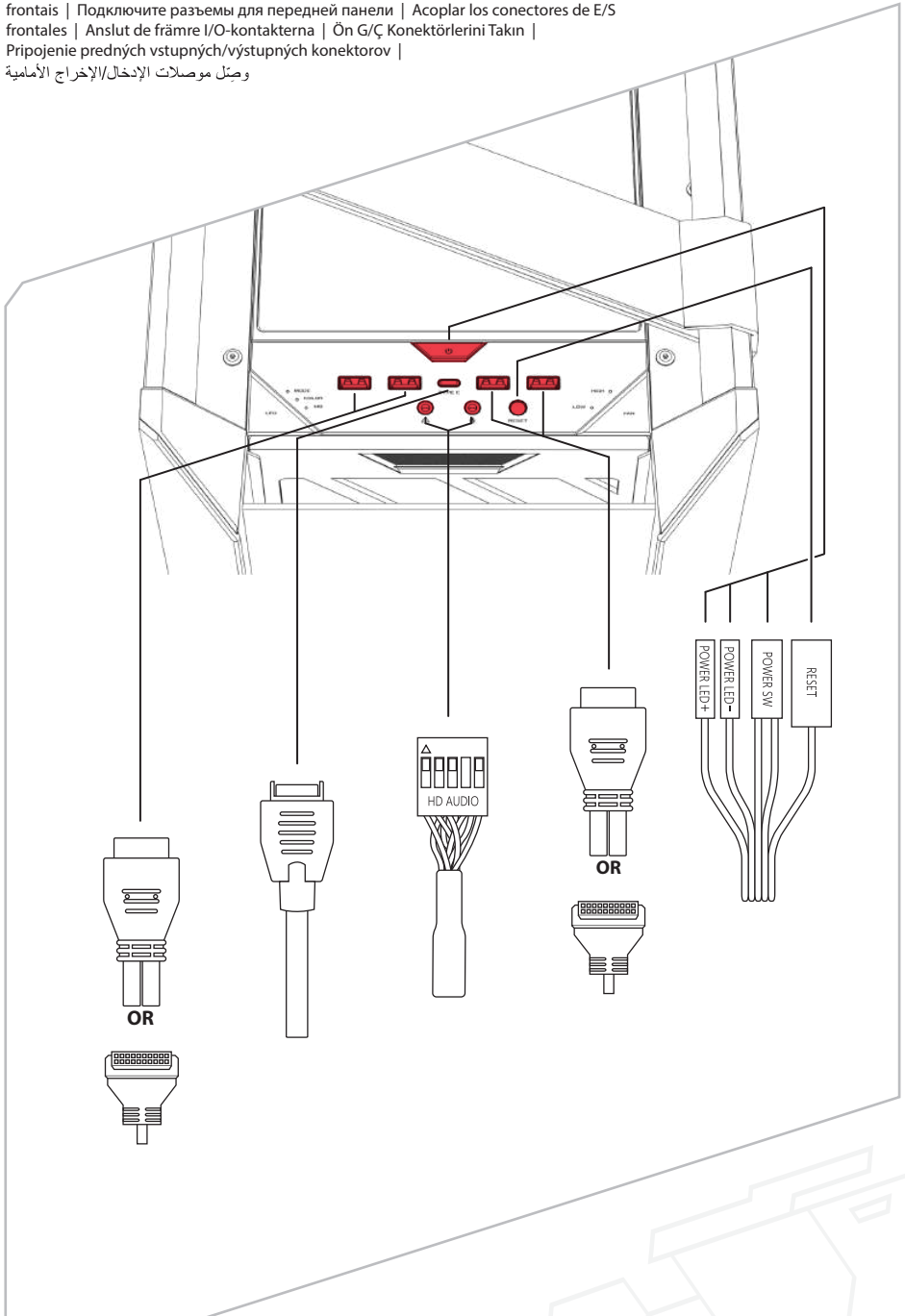

SYNC CASE LIGHTING WITH ADDRESSABLE RGB COMPATIBLE MOTHERBOARDS



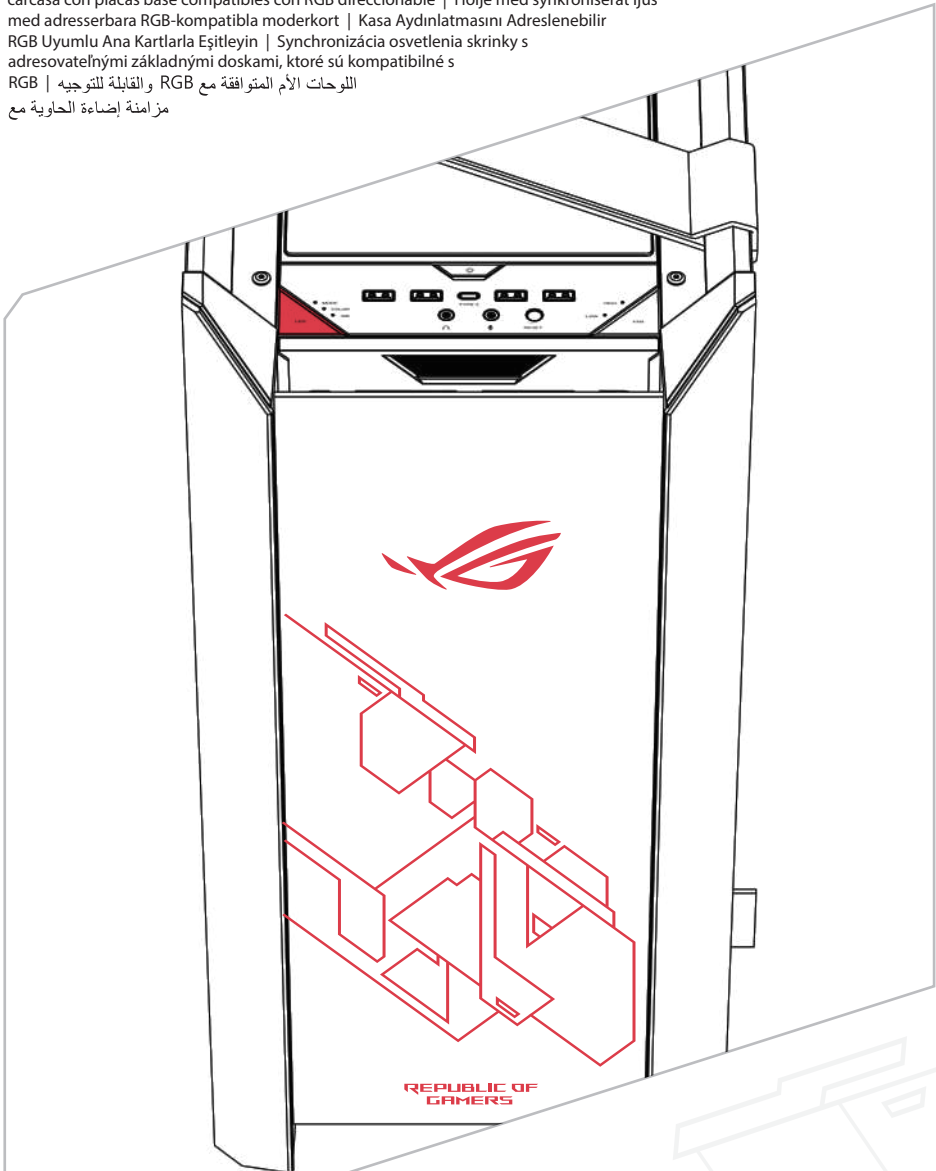

可編程RGB燈光與可兼容主機板同步燈光控制 | 可編程RGB灯效与可兼容主机板同步灯光控制 | Synchronizovat osvětlení skříně se základními deskami, které jsou kompatibilní s adresovatelným RGB | Synchroniser l'éclairage du châssis avec les cartes mères compatibles RGB adressables | Synchronisieren der Gehäusebeleuchtung über ansteuerbare RGB-kompatible Motherboards | Sincronizza l'illuminazione del case con le schede madri compatibili con l'indirizzamento RGB | アドレスابل LED対応マザーボードによるライティングの同期 | 주소 지정이 가능한 RGB를 채택한 싱크 케이스 조명 호환 메인보드 | Synchronizacja podświetlenia obudowy z płytami głównymi zgodnymi z adresowalnym podświetleniem RGB | Sincronize a iluminação da caixa com placas principais compatíveis com RGB endereçável | Синхронизировать подсветку корпуса с адресуемой RGB-лентой материнской платы | Sincronizar la iluminación de la carcasa con placas base compatibles con RGB direccionable | Hölje med synkroniserat ljus med adresserbara RGB-kompatibla moderkort | Kasa Aydınlatmasını Adreslenebilir RGB Uyumlu Ana Kartlarla Eşitleyin | Synchronizácia osvetlenia skrinky s adresovatelnými základnými doskami, ktoré sú kompatibilné s RGB | اللوحات الأم المتوافقة مع RGB والقابلة للتوجيه | مزانة إضاءة الحاوية مع

مزامنة إضاءة الحاوية مع

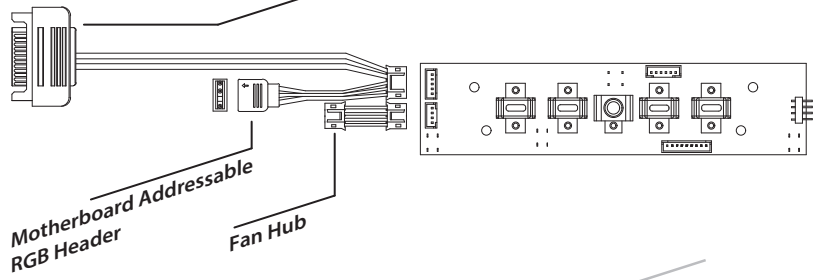

Connect to Power Supply



- Turn On Press LED button for 6 seconds
- Turn Off Press LED button for 6 seconds
- Mode Change Press LED button for 2 seconds
- Back to Default Press LED button for 4 seconds
- MB Sync up with M/B Lighting
- Mode
 Static
  Breathing
  Strobing
  Rainbow
- Color
 White/Red/Orange/Yellow/Green
 Blue/Cyan/Purple/Rainbow
- Default Mode :Rainbow Color: Rainbow

*MB mode only works when connecting control board to MB Addressable RGB header
 *Compatible with ARUA Sync

FAN HUB CONNECTIVITY

風扇集線器 | 風扇集线器 | Možnosti připojení rozbočovače ventilátoru | Connectivité du hub pour ventilateur | Verbindungsfähigkeit der Lüfterabene | Connettività dell'hub per ventole | ファンハブの接続方法 | 팬 허브 연결 | Połączenia koncentratora wentylatorów | Conectividad de hub de ventiladores | Подключение концентратора для вентиляторов | Conectividad del concentrador del ventilador | Hubbanslutning för fläkt | Fan Göbeği Bağlanabilirliği | Pripojitelnost rozbočovača ventilatora | توصيل صرة المروحة

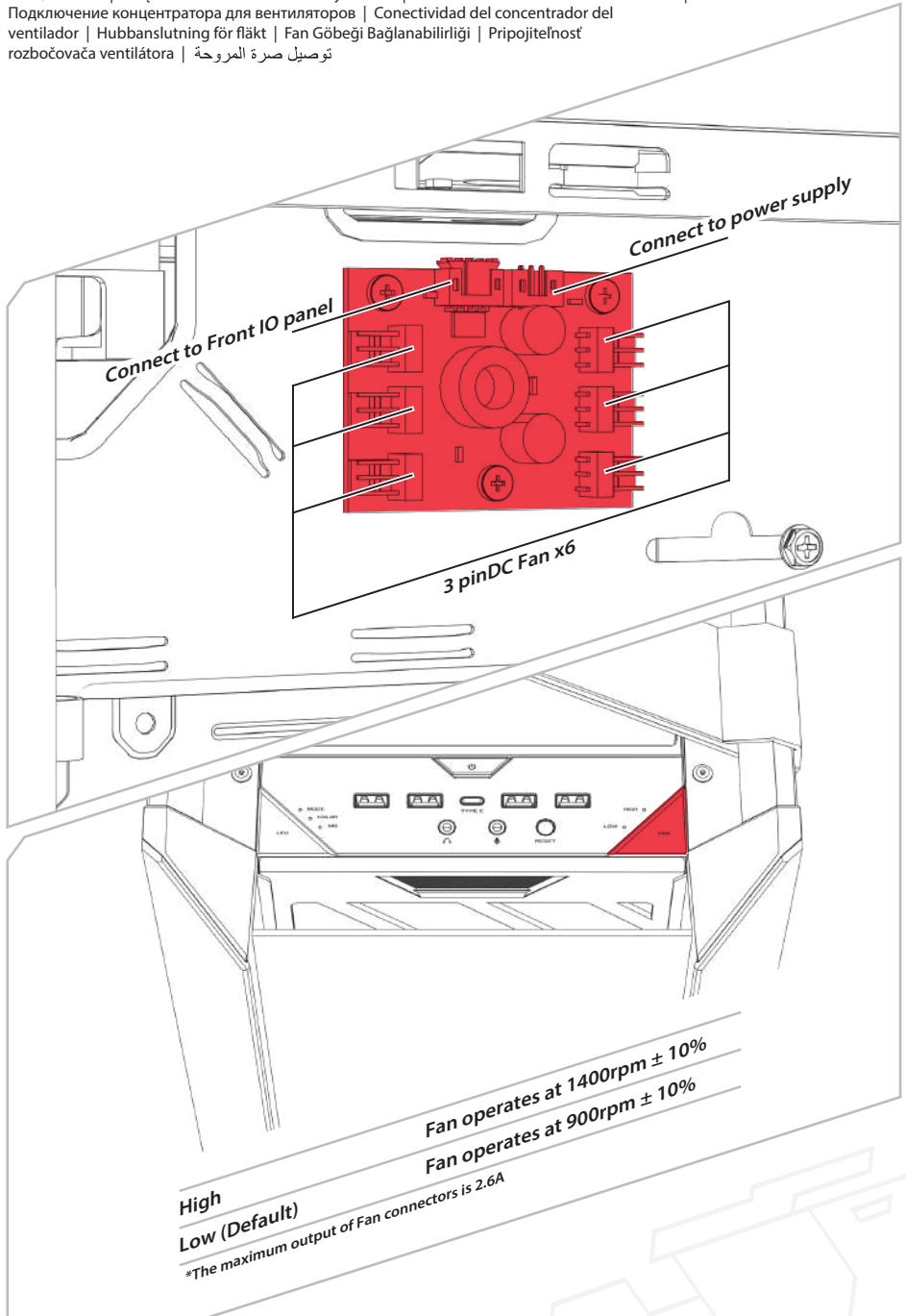

INSTALL THE PCI-E CARD

安裝 PCI-E 卡 | 安裝 PCI-E 卡 | Nainstalujte PCI-E kartu | Installer la carte PCI-E | Installation der PCI-E-Karte |
Installate la scheda PCI-E | 拡張カードを取り付ける | PCI-E 카드 설치 | Zainstaluj kartę PCI-E | Instalar a
placa PCI-E | Установите карту PCI-E | Instalar la tarjeta PCI-E | Installera PCI-E-kortet | PCI-E Kartini
Takim | Instalácia karty PCI-E | PCI-E بطاقة ركب

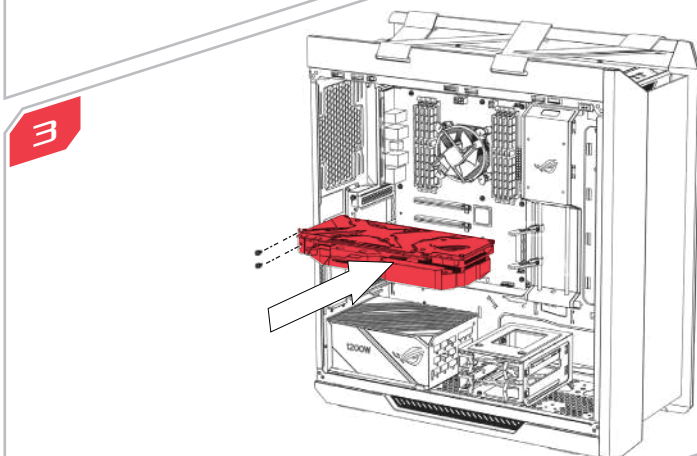
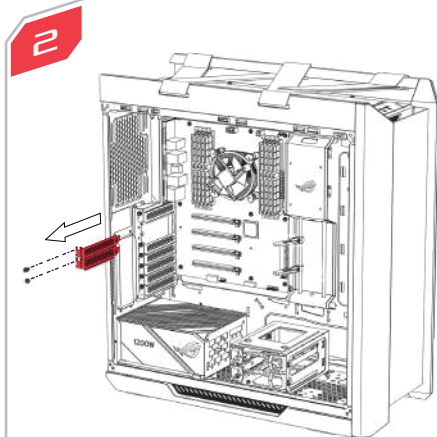
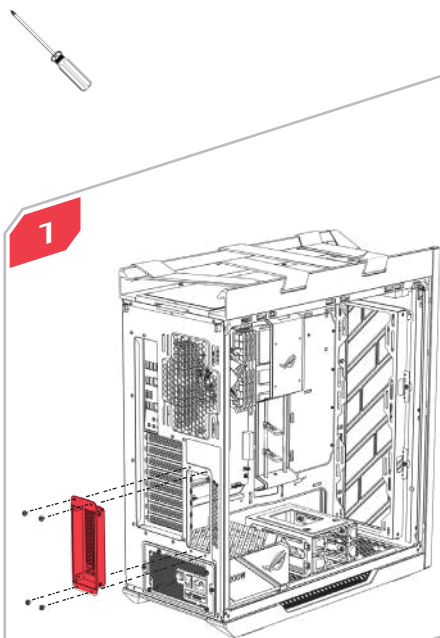

INSTALL THE 2.5" DRIVES

安裝 2.5 吋硬碟或固態硬碟 | 安裝 2.5 英寸硬盤或固態硬盤 | Nainstalujte 2,5" jednotky | Installer les lecteurs 2.5" | Installation der 2,5-Zoll-Laufwerke | Installate i drive 2.5" | 2.5 インチ ドライブ を取り付ける | 2.5" 드라이브 설치 | Zainstaluj napędy 2,5" | Instalar as unidades de 2,5" | Установите 2,5-дюймовые диски | Instalar las unidades de 2,5" | Installera 2,5"-enheterna | 2,5" Sürücülerini Takın | Inštalácia 2,5" jednotiek | تركيب المحركات بمقاس 2,5 بوصة

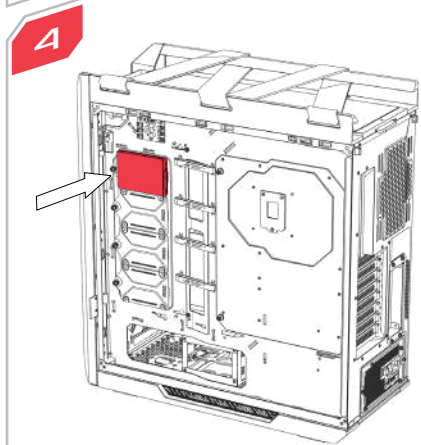
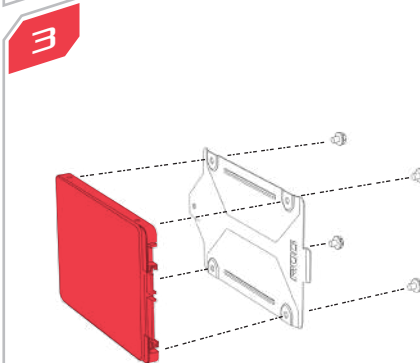
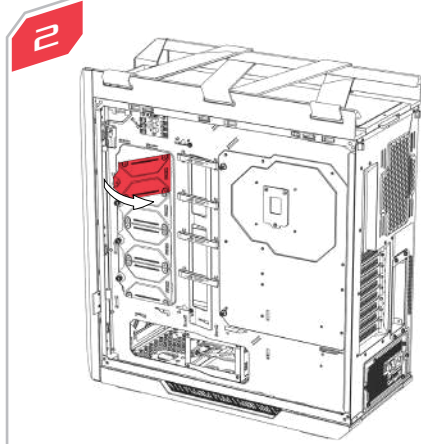
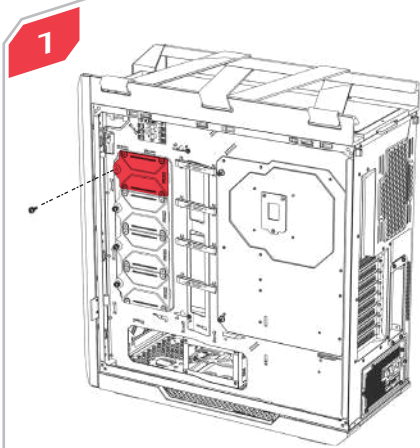
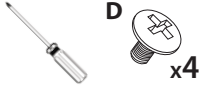

INSTALL THE 3.5" / 2.5" DRIVES

安裝 3.5 / 2.5 吋硬碟 | 安裝 3.5 / 2.5 英寸硬盤 | Nainstalujte 3,5"/2,5" jednotky | Installer les lecteurs 3.5"/2.5" | Installation der 3,5-Zoll-/2,5-Zoll-Laufwerke | Installate i drive 3.5"/2.5" | 3.5インチ/2.5インチドライブを取り付ける | 3.5"/2.5" 드라이브 설치 | Zainstaluj napędy 3,5"/2,5" | Instalar as unidades de 3,5"/2,5" | Установите 3,5/2,5-дюймовые диски | Instalar las unidades de 3,5"/2,5" | Installera 3,5"/2,5"-enheterna | 3,5"/2,5" Sürücülerini Takın | Inštalácia 3,5"/2,5" jednotiek | ركب المحر كاتمقاس 2,5/3,5 بوصة

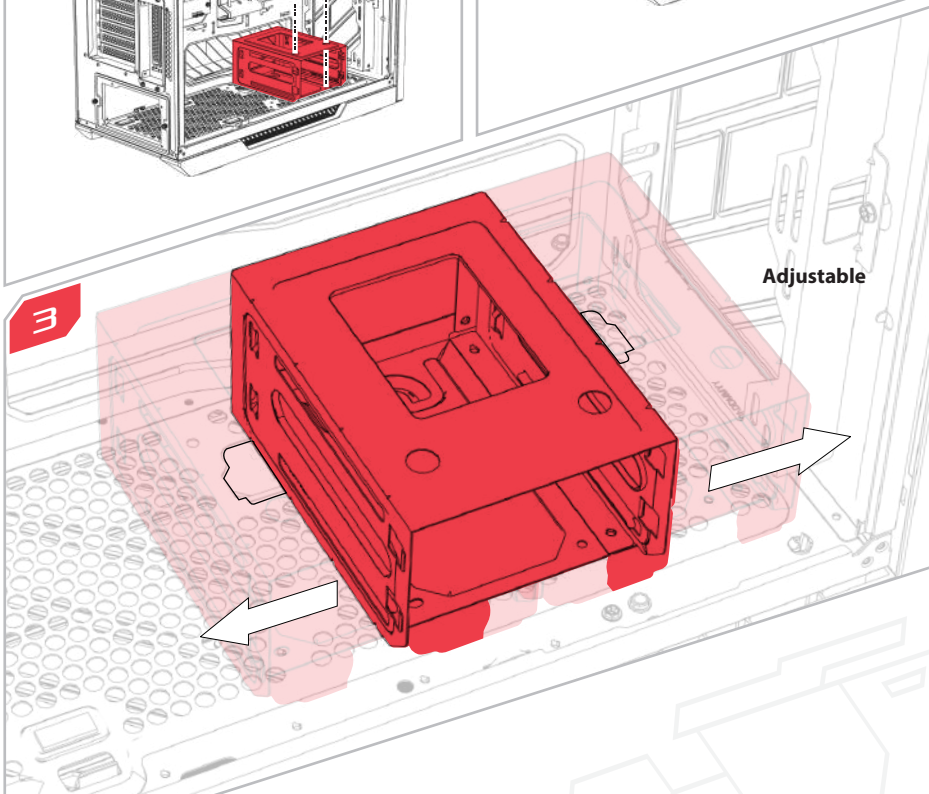
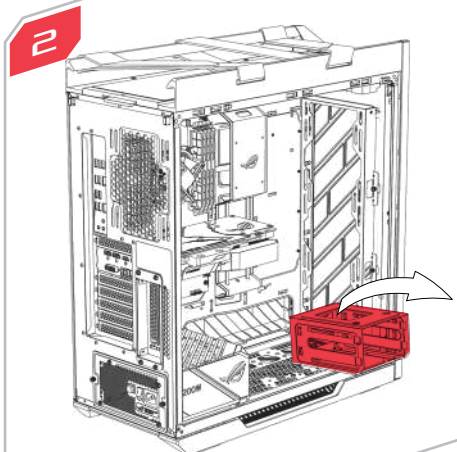
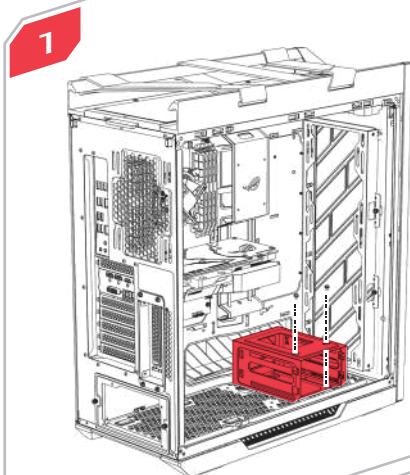
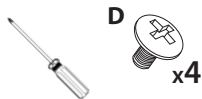

1

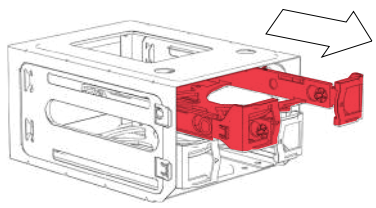

2

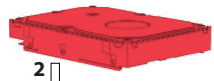
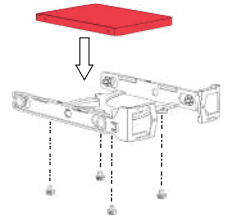

1



3

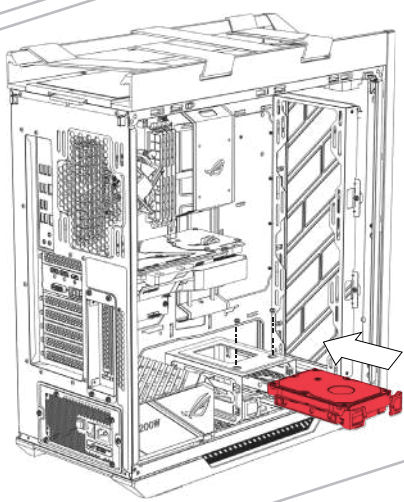

INSTALLATION AND MAINTENANCE OF THE DUST FILTERS

防塵網安裝及保養 | 防尘网安装及保养 | Instalace a údržba prachových filtrů | Installation et entretien des filtres à poussière | Installation und Wartung der Staubfilter | Installazione e manutenzione dei filtri antipolvere | ダストフィルターを取り付ける | 먼지 필터의 설치 및 유지보수 | Instalacja i konserwacja filtrów antykurzowych | Instalação e manutenção dos filtros de pó | Установка и обслуживание пылевых фильтров | Instalación y mantenimiento de los filtros de polvo | Installation och underhåll av dammfiltren | Toz Filtrelerinin Kurulumu ve Bakımı | Inštalácia a údržba prachových filtrov | تركيب وصيانة فلتر الغبار

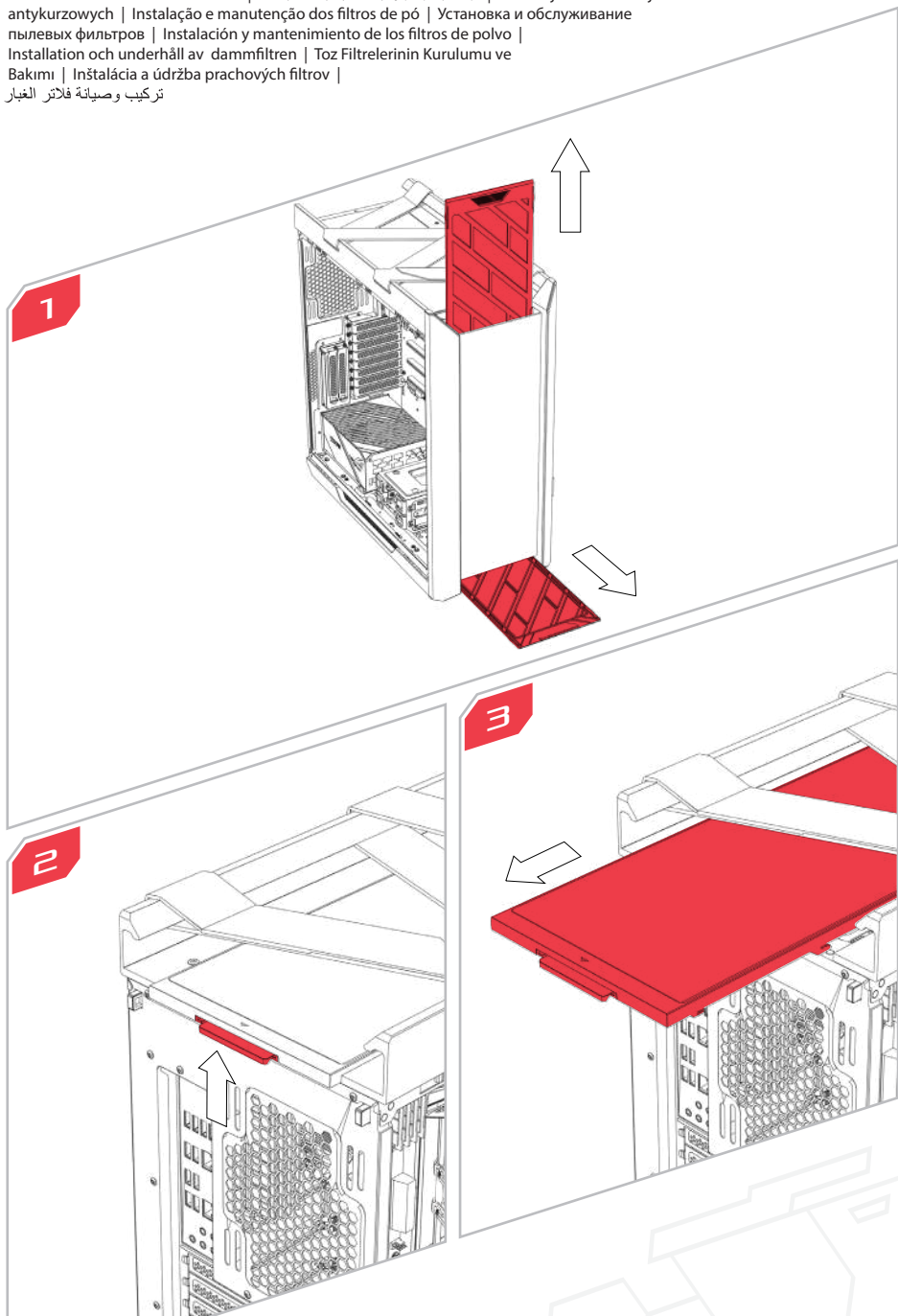

PUMP INSTALLATION

幫浦安裝 | 水泵安裝 | Instalace čerpadla | Installation de la pompe | Installation der Pumpe | Installazione della pompa | 水冷ポンプの取り付け | 펌프 설치 | Instalacja pompy | Instalação da bomba | Установка помпы | Instalación de la bomba | Pumpinstallation | Pompa Kurulumu | Inštalácia čerpadla | تركيب المضخة



1

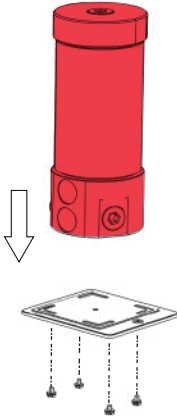

2

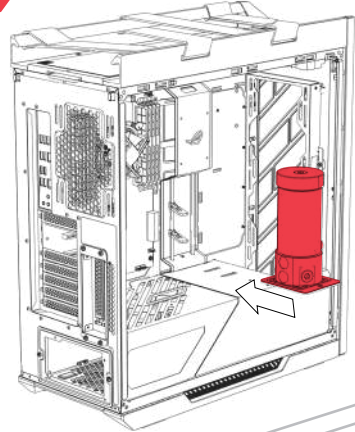

3

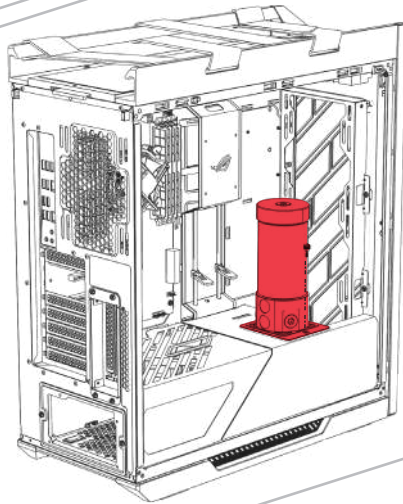

ADDITIONAL INFORMATION



附加資訊 | 附加信息 | Dodatečné informace | Informations supplémentaires | Zusätzliche Informationen | Informazioni
addizionali | 追加情報 | 추가 정보 | Informacje dodatkowe | Informações adicionais | Дополнительная информация |
Información adicional | Ytterligere information | Ek Bilgiler | Doplnkové informácie | معلومات إضافية

CPU COOLER HEIGHT LIMITATION

CPU 散熱器高度限制 | CPU 散熱器高度限制 | Výškové omezení chladiče CPU | Limitation de hauteur du refroidisseur pour processeur | Höhenbegrenzung des CPU-Kühlers | Limitazioni di altezza per il dissipatore CPU | CPUクーラーの制限 | CPU 쿨러 높이 제한 | Ograniczenie wysokości elementu chłodzącego CPU | Limitação de altura do dissipador da CPU | Ограничения для высоты процессорного кулера | Limitación de la altura del refrigerador de la CPU | Höjdbegränsning av CPU-kyllare | CPU Soğutucu Yükseklik Sınırlaması | Obmedzenie výšky chladiča jednotky centrálného procesora | حد ارتفاع مبرد وحدة المعالجة المركزية

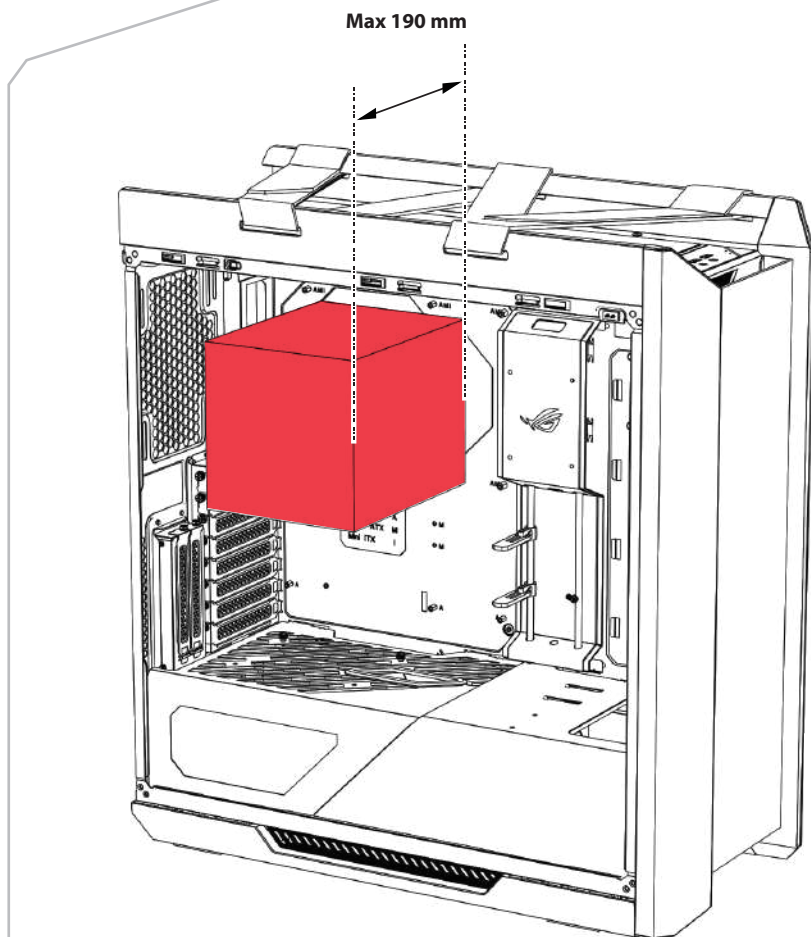

GRAPHICS CARD LIMITATION

顯示卡長度限制 | 显卡长度限制 | Omezení grafické karty | Limitations de la carte graphique | Beschränkungen der Grafikkarte | Limitazioni per la scheda grafica | グラフィックスカードの制限 | 그래픽 카드 제한 | Ograniczenia karty graficznej | Limitações de placas gráficas | Ограничения для видеокарты | Limitaciones de la tarjeta gráfica | Begränsningar för grafikkort | Grafik Kartı Sınırlamaları | Obmedzenia grafickej karty | حدود بطاقة الرسومات

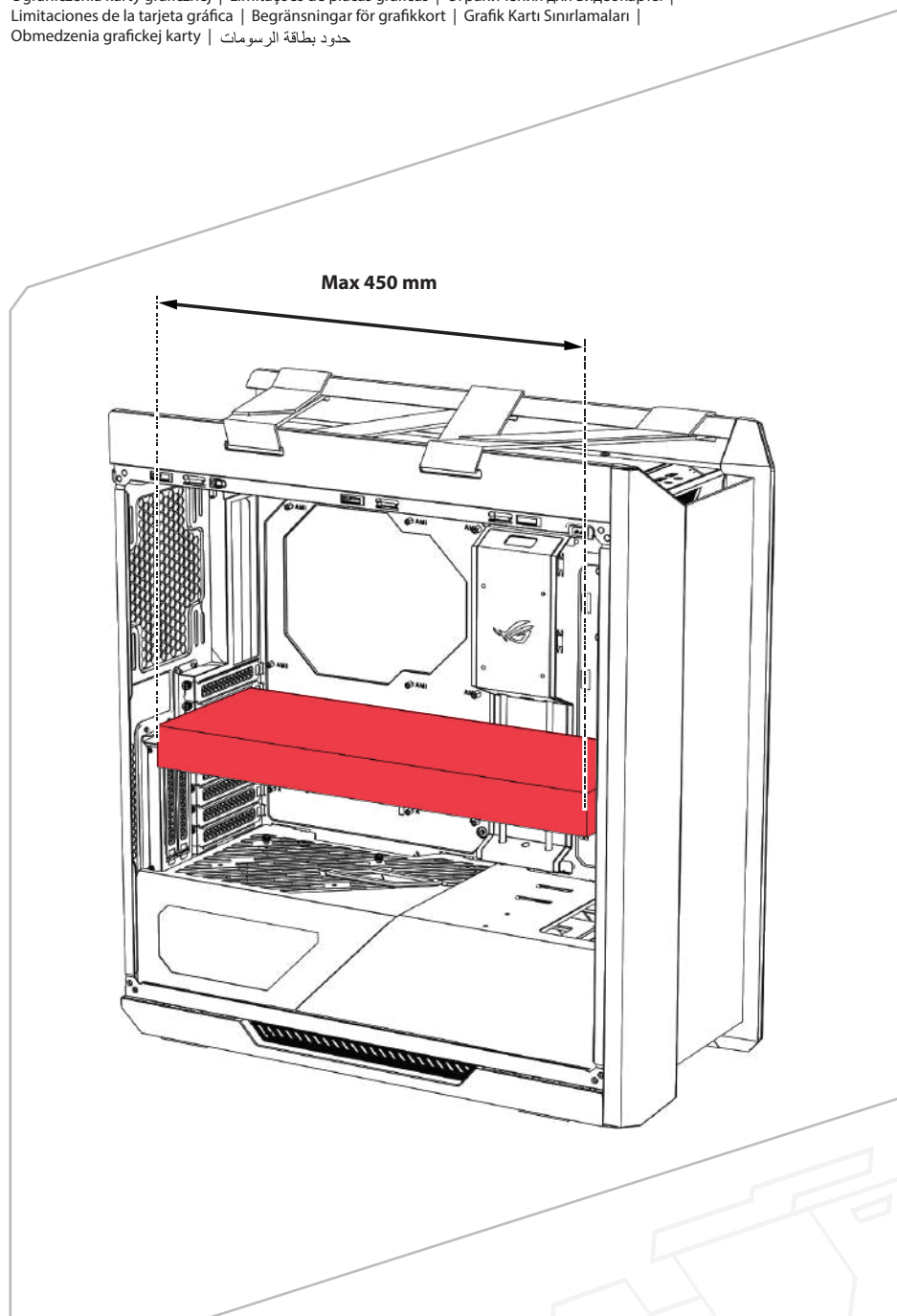

GRAPHICS CARD PLACEMENT OPTIONS

顯示卡替代放置 | 显卡放置位置 | Možnosti umístění grafické karty | Options de positionnement de la carte graphique | Platzierungsoptionen für Grafikkarten | Opzioni di installazione della scheda grafica | グラフィックスカードの設置方法 | 그래픽 카드 배치 옵션 | Opcje montażu karty graficznej | Opções de colocação da placa gráfica | Варианты размещения видеокарты | Opciones de ubicación de la tarjeta gráfica | Placeringsalternativ för grafikkort | Grafik Kartı Yerleştirme Seçenekleri | Možnosti umiestnenia grafickej karty | خيارات وضع بطاقة الرسومات



1
Install a GPU in vertical position

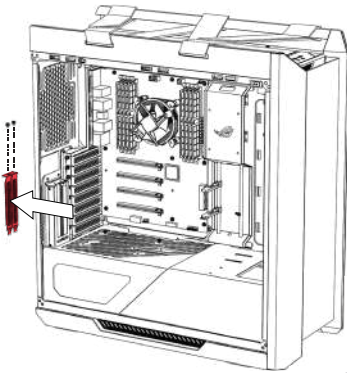

2

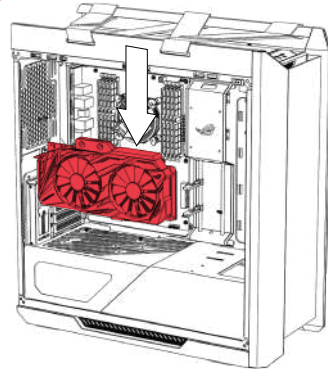

*Requires riser cable (not included)

1
Install Dual Vertical GPUs

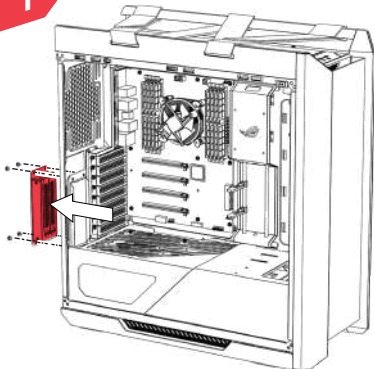

2

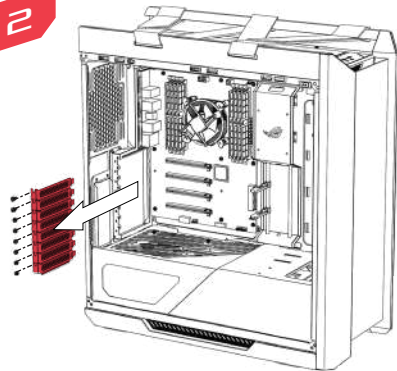

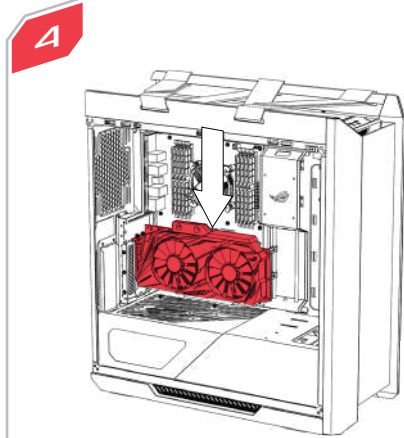
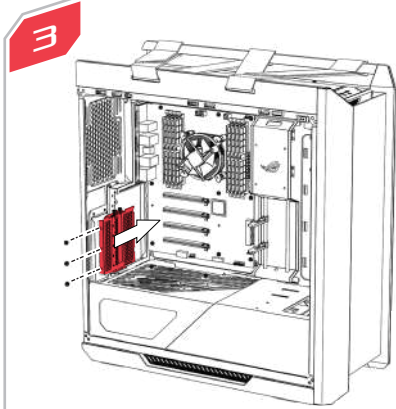

**Requires riser cable (not included)*

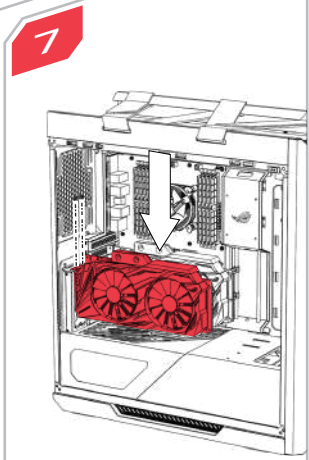
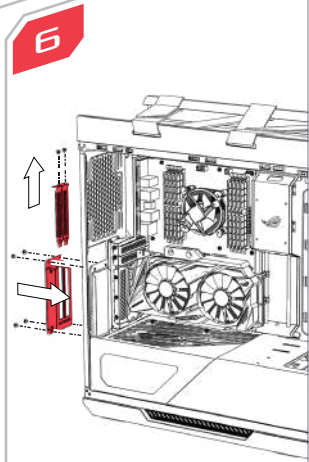
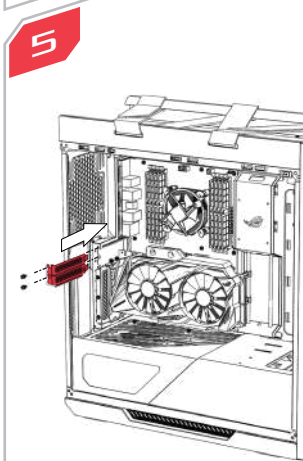

**Requires riser cable (not included)*

FAN SETUP COMPATIBILITY

風扇設定相容性 | 風扇設置兼容性 | Kompatibilita nastavení ventilátoru | Compatibilité de configuration du ventilateur
| Kompatibilität der Lüftereinrichtung | Specifiche di installazione per le ventole | ファンの取り付け例 |
팬 설치 호환성 | Zgodność instalacji wentylatora | Compatibilidade de ventiladores |
Совместимость устанавливаемого вентилятора | Compatibilidad de la configuración del
ventilador | Kompatibilitet för fläktinstallation | Fan Kurulumu Uyumluluğu |
Kompatibilita nainštalovania ventilátora | توافق إعداد المروحة



120 mm

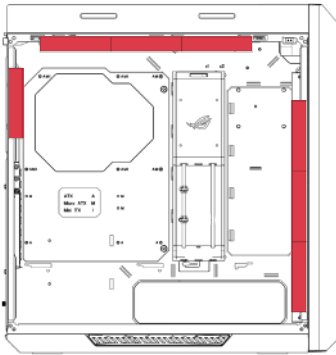

140 mm

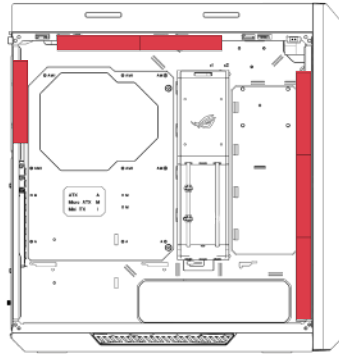

Top

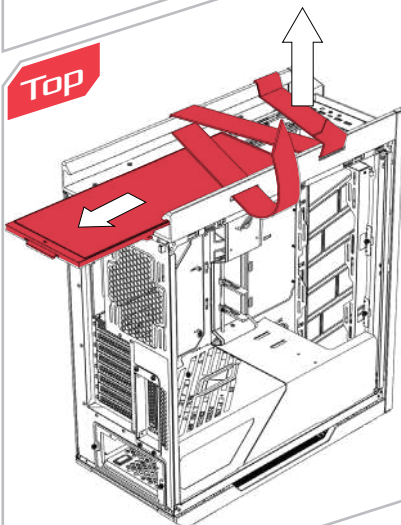

Top

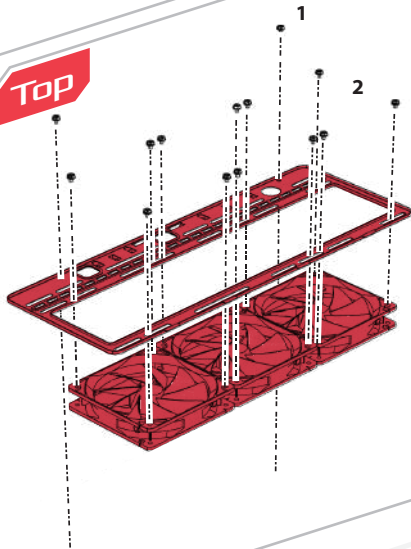

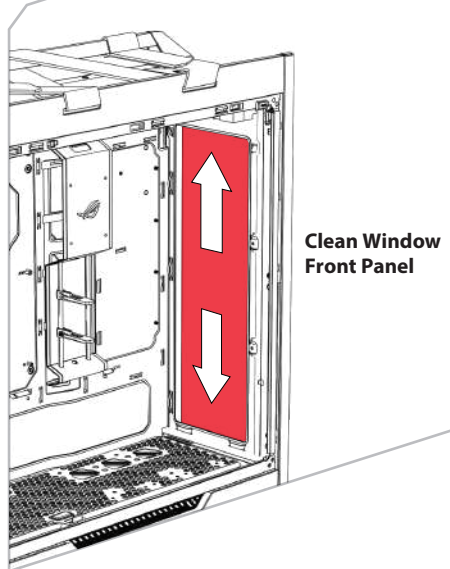
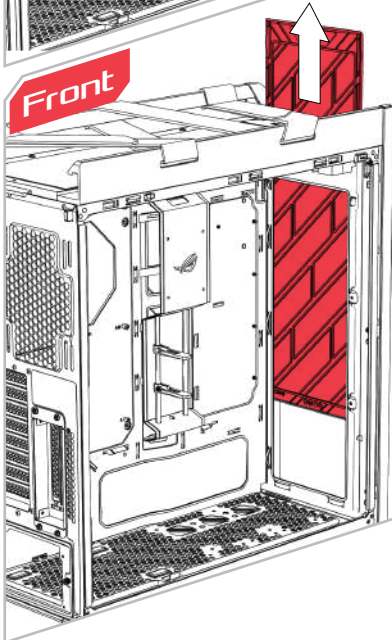
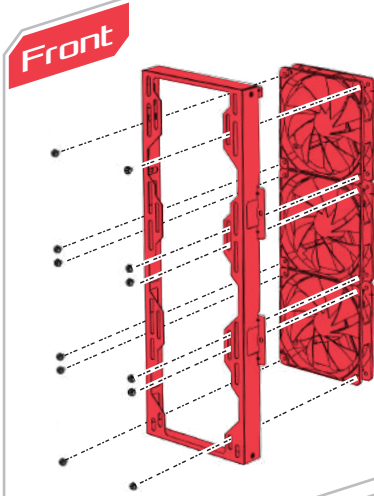
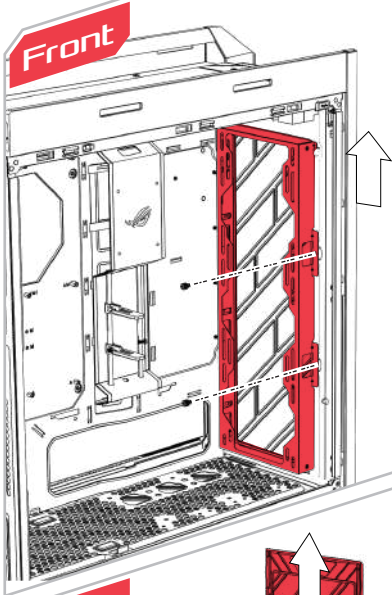

WATER-COOLING RADIATOR OPTIONS

水冷散熱系統選項 | 水冷散熱系統選項 | Možnosti chladiče vodního chlazení | Options de radiateur à refroidissement par eau | Optionen der Wasserkühlung | Opzioni per radiatore raffreddamento a liquido | 水冷ラジエーターの制限 | 수냉식 라디에이터 옵션 | Opcje instalacji radiatora chłodzonego wodą | Opções de radiadores de refrigeração a água | Варианты радиатора для водяного охлаждения | Opciones del radiador de refrigeración por agua | Alternativ för vattenkylningselement | Su Soğutma Radyatörü Seçenekleri | Možnosti chladiča na chladienie vodou | خيارات مشع تبريد المياه

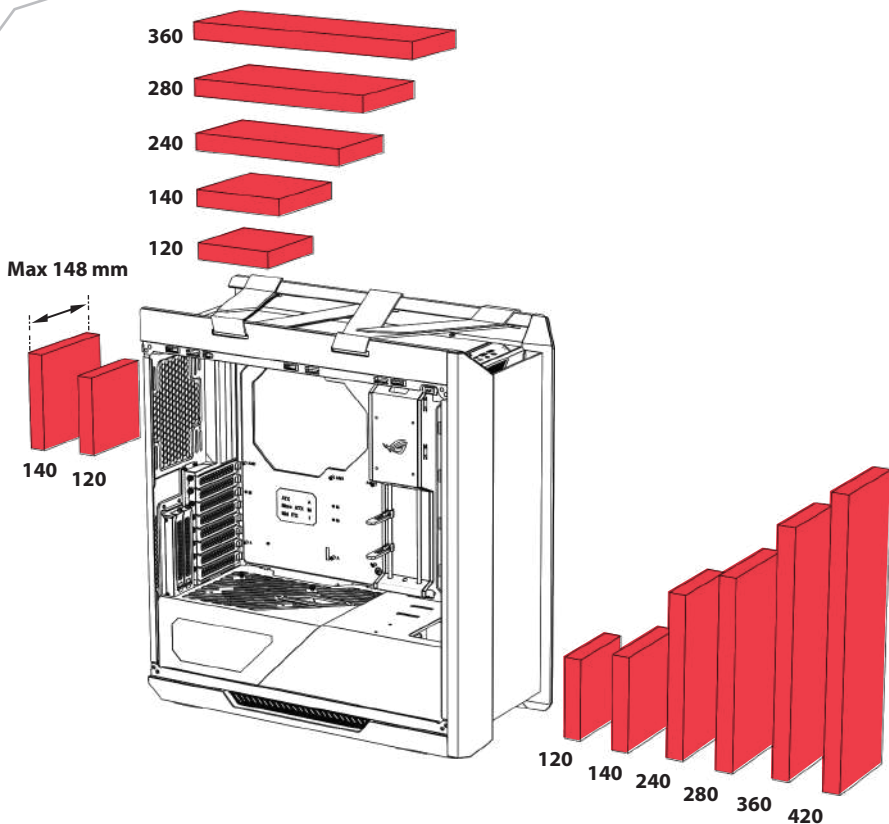

WATER-COOLING SETUP COMPATIBILITY

水冷散熱系統設定相容性 | 水冷散熱系統設置相容性 | Kompatibilita nastavení vodního chlazení | Compatibilité de configuration du refroidissement par eau | Kompatibilität der Wasserkühlungseinrichtung | Specifiche di installazione raffreddamento a liquido | ラジエーターとファンの制限 | 수냉식 설치 호환성 | Zgodność instalacji chłodzenia wodą | Compatibilidade de radiadores de refrigeração a água | Совместимость с водяным охлаждением | Compatibilidad de la configuración de refrigeración por agua | Kompatibilitet för vattenkylningsinstallation | Su Soğutma Kurulumu Uyumluluğu | Kompatibilita inštalácie chladenia vodou | توافق إعداد تبريد المياه

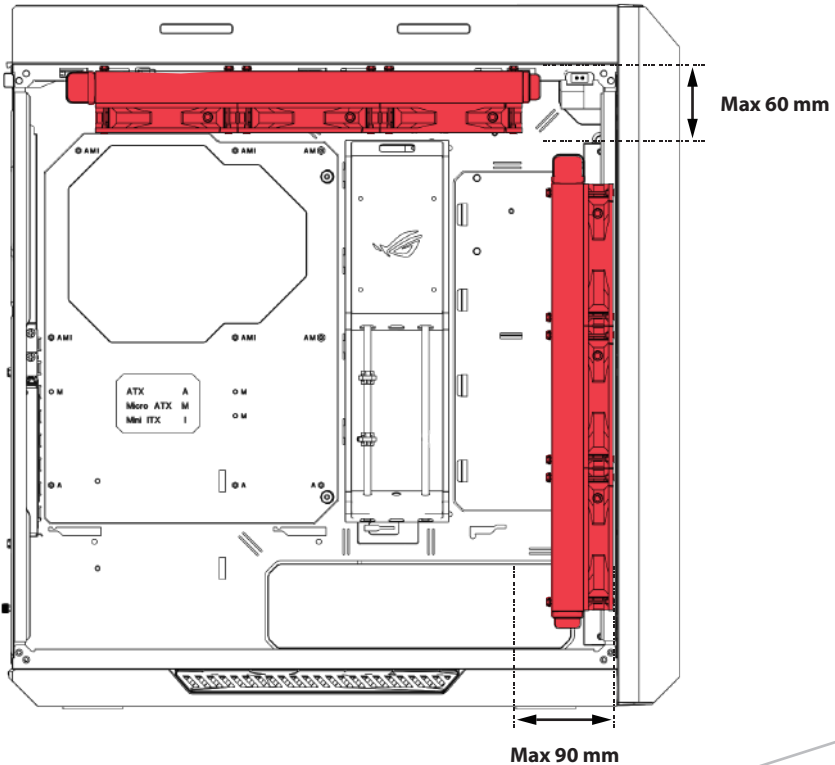

RECOMMENDED HANDLE CONFIGURATION

提把建議使用方式 | 提把建議使用方式 | Doporučená ruční konfigurace | Configuration de poignée recommandée | Empfohlene Griffeneinrichtung | Configurazione raccomandata per i manici | ハンドルの使用方法 | 권장 핸들 구성 | Zalecana konfiguracja uchwytu | Configuração recomendada para pegas | Рекомендуемое использование ручек | Configuración recomendada del asa | Rekomenderad hanteringskonfiguration | Önerilen Kol Konfigurasyonu | Odporučaná konfigurácia rúčky | التهيئة الموصى بها للمقبض

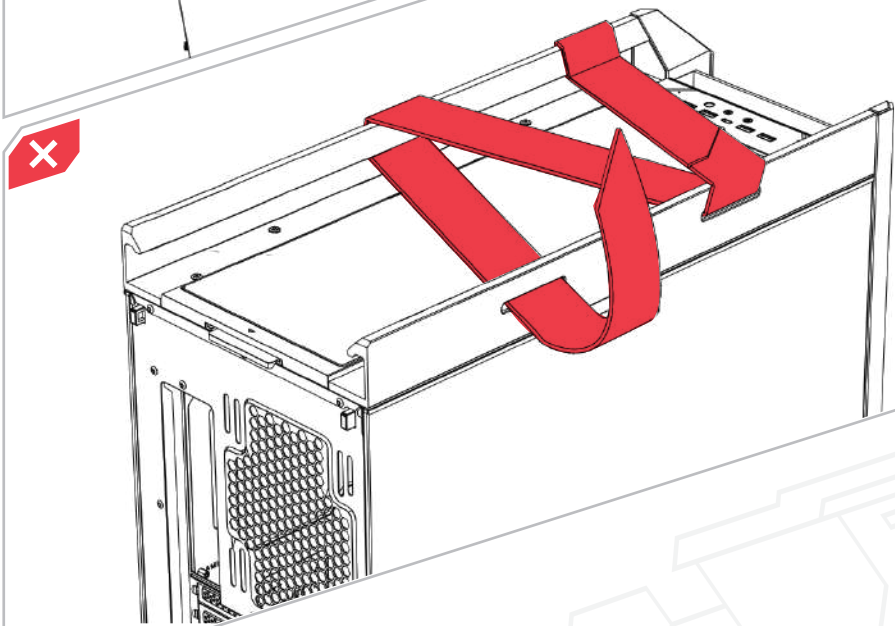
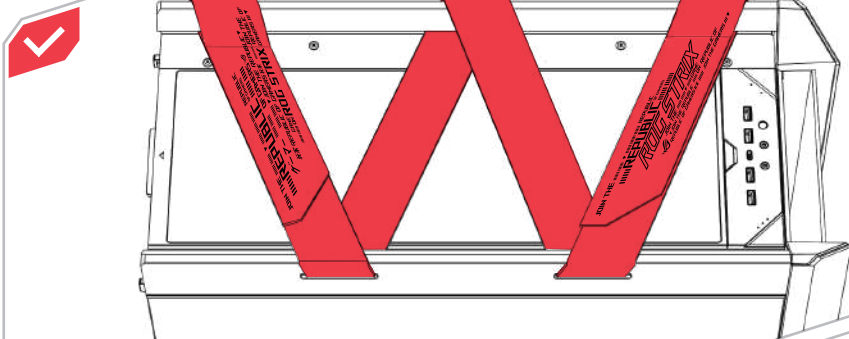

OPTIONAL UPGRADES



選配 | 選配 | Voliteľné aktualizace | Mises à niveau facultatives | Optionale Upgrades | Espansioni opzionali | アップグレードオプション | 옵션 업그레이드 | Opcjonalne elementy rozbudowy | Atualizações opcionais | Дополнительная модернизация | Actualizaciones opcionales | Valfría uppgraderingar | İsteğe Bağlı Yükseltmeler | Voliteľné inovácie |

ترقيات اختيارية

ROG AURA TERMINAL

ASUS ROG Aura Terminal Addressable RGB Controller with four-ports, three magnetic LED strips, Halo and AURA Sync RGB software

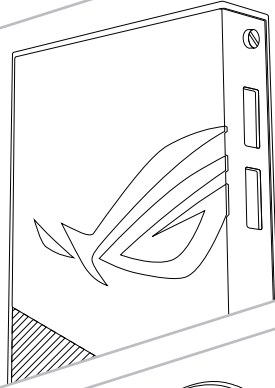

*Compatible with ARUA Sync

ROG ADDRESSABLE LED STRIP

ASUS ROG Addressable RGB 5050 LED Lighting Strip with Magnetic Backing and Adhesive Strips for use with AURA Sync RGB Lighting Software

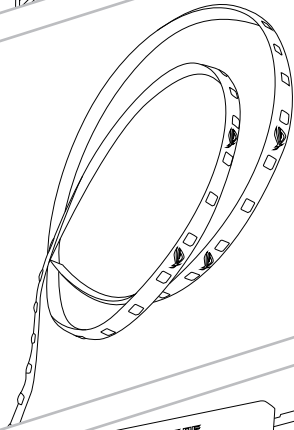

*Compatible with ARUA Sync

ROG RISER CABLE

A GPU In Vertical Position

Riser Cable above 200mm in length is required

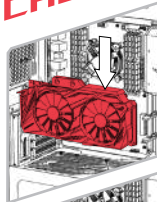

Dual-Vertical GPUs

1st place Riser Cable
Length: 163 ± 5mm

2nd place Riser Cable
Length: 135 ± 5mm

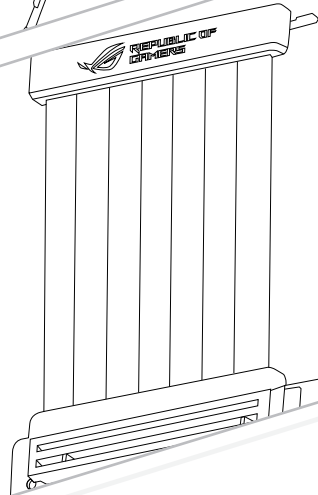
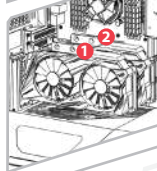

SAFETY INFORMATION



安規資訊 | 安規信息 | Bezpečnostní informace | Informations relatives à la sécurité | Sicherheitsinformationen | Informazioni sulla sicurezza | 製品の安全性に関する情報 | 안전 정보 | Informacje dotyczące bezpieczeństwa | Informações de segurança | Информация о правилах безопасности | Información de seguridad | Säkerhetsinformation | Güvenlik Bilgileri | Bezpečnostné informácie | معلومات السلامة

ASUS Recycling / Takeback Services

ASUS recycling and takeback programs come from our commitment to the highest standards for protecting our environment. We believe in providing solutions for our customers to be able to responsibly recycle our products, batteries and other components as well as the packaging materials. Please go to <http://csr.asus.com/english/Takeback.htm> for detail recycling information in different region.

Australia Statement Notice

From 1 January 2012 updated warranties apply to all ASUS products, consistent with the Australian Consumer Law. For the latest product warranty details please visit <http://support.asus.com>. Our goods come with guarantees that cannot be excluded under the Australian Consumer Law. You are entitled to a replacement or refund for a major failure and compensation for any other reasonably foreseeable loss or damage. You are also entitled to have the goods repaired or replaced if the goods fail to be of acceptable quality and the failure does not amount to a major failure. If you require assistance please call ASUS Customer Service 1300 2787 88 or visit us at <http://support.asus.com>.

India RoHS

This product complies with the "India E-Waste (Management) Rules, 2016" and prohibits use of lead, mercury, hexavalent chromium, polybrominated biphenyls (PBBs) and polybrominated diphenyl ethers (PBDEs) in concentrations exceeding 0.1% by weight in homogenous materials and 0.01% by weight in homogenous materials for cadmium, except for the exemptions listed in Schedule II of the Rule.

REACH

Complying with the REACH (Registration, Evaluation, Authorisation, and Restriction of Chemicals) regulatory framework, we published the chemical substances in our products at ASUS REACH website at <http://csr.asus.com/english/REACH.htm>. (English)

謹遵守REACH(Registration, Evaluation, Authorisation, and Restriction of Chemicals)管理規範。我們會將產品中的化學物質公告在華碩REACH網站。詳細請參考<http://csr.asus.com/english/REACH.htm>。(繁體中文)

謹遵守REACH(Registration, Evaluation, Authorisation, and Restriction of Chemicals)管理規範。我們將會將產品中的化學物質公告在華碩REACH網站。詳細請參考<http://csr.asus.com/english/REACH.htm>。(簡體中文)

V rámci shody s regulační platformou REACH (Registration, Evaluation, Authorisation, and Restriction of Chemicals (registrace, hodnocení, povolování a omezování chemických látek)) byl zveřejněn seznam chemických látek přítomných v našich produktech na webu ASUS REACH na adrese <http://csr.asus.com/english/REACH.htm>. (Čeština)

Conforme avec le Règlement REACH (Enregistrement, Évaluation, Autorisation et Restriction des produits chimiques), nous avons publié la liste des substances chimiques utilisées dans nos produits sur le site Web ASUS REACH à l'adresse <http://csr.asus.com/english/REACH.htm>. (Français)

Die rechtliche Rahmenbedingungen für REACH (Registration, Evaluation, Authorisation, and Restriction of Chemicals) erfüllend, veröffentlichen wir die chemischen Substanzen in unseren Produkten auf unserer ASUS REACH-Webseite unter <http://csr.asus.com/english/REACH.htm>. (Deutsch)

Nel rispetto del regolamento REACH (Registration, Evaluation, Authorisation, and Restriction of Chemicals), le sostanze chimiche contenute nei prodotti ASUS sono state pubblicate nel sito web ASUS, alla pagina: <http://csr.asus.com/english/REACH.htm>. (Italiano)

REACH (Registration, Evaluation, Authorisation, and Restriction of Chemicals) 規則の基準を満たすため、ASUSはREACH専用サイトで弊社製品に含まれる化学物質を公開しております。 <http://csr.asus.com/english/REACH.htm>. (日本語)

REACH (Registration, Evaluation, Authorisation, and Restriction of Chemicals) 등록, 평가, 승인 및 화학물질규제) 규제 기준을 준수하여 ASUS REACH 웹사이트 <http://csr.asus.com/english/REACH.htm> 에 당사 제품에 사용된 화학 물질을 게시했습니다. (한국어)

Zgodnie z rozporządzeniem REACH (Rejestracja, ocena, autoryzacja i ograniczenie środków chemicznych), publikujemy informacje o środkach chemicznych w naszych produktach, na stronie internetowej ASUS REACH pod adresem <http://csr.asus.com/english/REACH.htm> (Polski)

Cumprindo o quadro regulamentar REACH (Registo, Avaliação, Autorização e Restrição dos Produtos Químicos), divulgamos as substâncias químicas incluídas nos nossos produtos no Web site ASUS REACH em <http://csr.asus.com/english/REACH.htm>. (Português)

Согласно регламенту ЕС REACH (Registration, Evaluation, Authorization, and Restriction of Chemicals – Регистрация, Оценка, Разрешения и Ограничения на использование Химических веществ), на сайте ASUS REACH размещен список химических веществ содержащихся в наших продуктах: <http://csr.asus.com/english/REACH.htm>. (Русский)

En cumplimiento del marco reglamentario REACH (registro, evaluación, autorización y restricción de productos químicos), hemos publicado las sustancias que contienen nuestros productos a través del sitio web ASUS REACH, al que puede acceder a través de la dirección <http://csr.asus.com/english/REACH.htm>. (Español)

Uppfyller REACH (Registration, Evaluation, Authorization, and Restriction of Chemicals (Registrering, Värdering, Behörighet och Begränsning)) reglerande regelverk, vi publicerar de kemiska substanserna i våra produkter på ASUS REACH webbsida på <http://csr.asus.com/english/REACH.htm>. (Svenska)

REACH (Kimyasalların Kayıt Altına Alınması, Değerlendirilmesi, Ruhsatlandırılması ve Sınırlandırılması) düzenleyici çerçevesine uygun olarak, ürünlerimizdeki kimyasal maddeleri <http://csr.asus.com/english/REACH.htm> adresindeki ASUS REACH websitesinde yayınlamaktayız.. (Türkçe)

امتثالاً لأطار العمل التنظيمي الخاص بتسجيل المواد الكيميائية وتقييمها والتحقق عليها وتقييد استخدامها (REACH)، قمنا بنشر المواد الكيميائية المستخدمة في منتجاتنا على موقع ASUS REACH على العنوان <http://csr.asus.com/english/REACH.htm> (عربي)



电子电器产品有害物质限制使用标识要求：图中之数字为产品之环保使用期限。仅指电子电器产品中含有的有害物质不致发生外泄或突变从而对环境造成污染或对人身、财产造成严重损害的期限。

有害物质名称及含量说明标示：

| 部件名称 | 有害物质 | | | | | |
|-------|--------|--------|--------|--------------|------------|--------------|
| | 铅 (Pb) | 汞 (Hg) | 镉 (Cd) | 六价铬 (Cr(VI)) | 多溴联苯 (PBB) | 多溴二苯醚 (PBDE) |
| 机箱组 | ○ | ○ | ○ | ○ | ○ | ○ |
| 面板右组 | ○ | ○ | ○ | ○ | ○ | ○ |
| 面板左组 | ○ | ○ | ○ | ○ | ○ | ○ |
| I/O模组 | × | ○ | ○ | ○ | ○ | ○ |
| 风扇 | ○ | ○ | ○ | ○ | ○ | ○ |
| 零件包 | × | ○ | ○ | ○ | ○ | ○ |

本表格依据 SJ/T 11364 的规定编制。

○：表示该有害物质在该部件所有均质材料中的含量均在 GB/T 26572 规定的限量要求以下。

×：表示该有害物质至少在该部件的某一均质材料中的含量超出 GB/T 26572 规定的限量要求，然该部件仍符合欧盟指令 2011/65/EU 的规范。

备注：此产品所标示之环保使用期限，系指在一般正常使用状况下。

AEEE Yönetmeliğine Uygundur.



REPUBLIC OF
GAMERS