



GBH 2-28 Professional HEAVY DUTY

D | DV | DFV



Robert Bosch Power Tools GmbH
70538 Stuttgart
GERMANY

www.bosch-pt.com

1 609 92A 5N7 (2020.03) PS / 55



1 609 92A 5N7

- en Original instructions
- zh 正本使用说明书
- zh 原始使用說明書
- ko 사용 설명서 원본
- th หนังสือคู่มือการใช้งานฉบับต้นแบบ
- id Petunjuk-Petunjuk untuk Penggunaan Orisinal
- vi Bản gốc hướng dẫn sử dụng



English	Page	6
中文	页	14
繁體中文	頁	20
한국어	페이지	26
ไทย	หน้า	33
Bahasa Indonesia	Halaman	41
Tiếng Việt	Trang	47

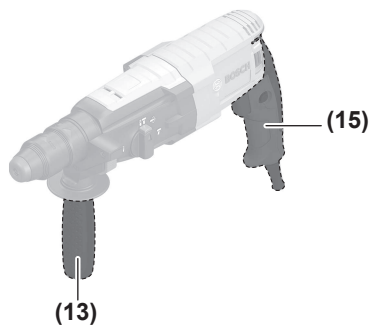
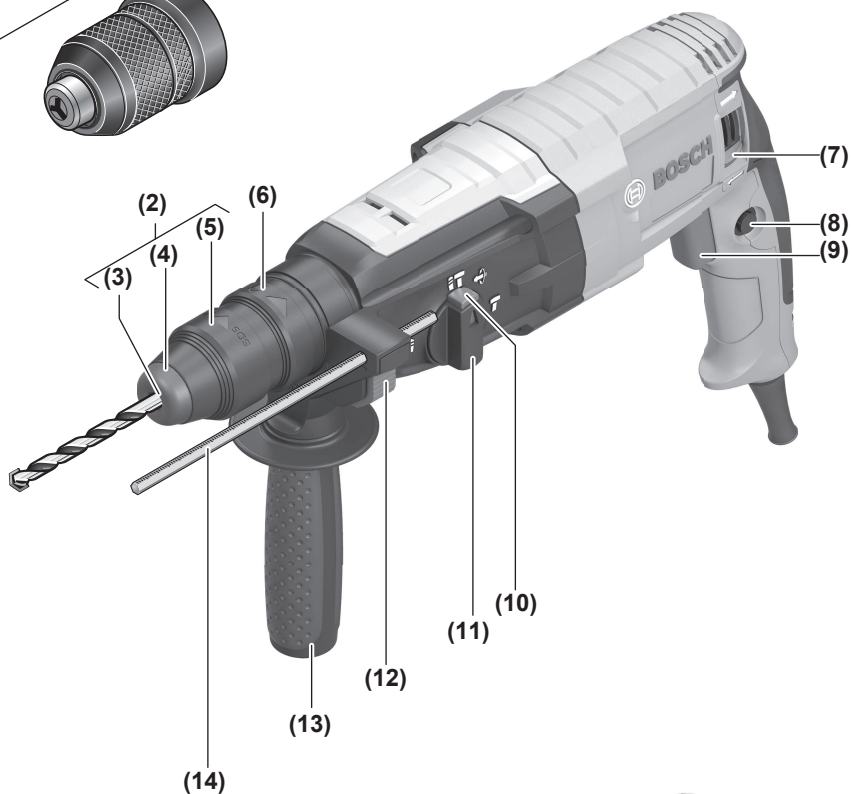
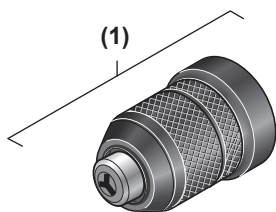

GBH 2-28 DFV

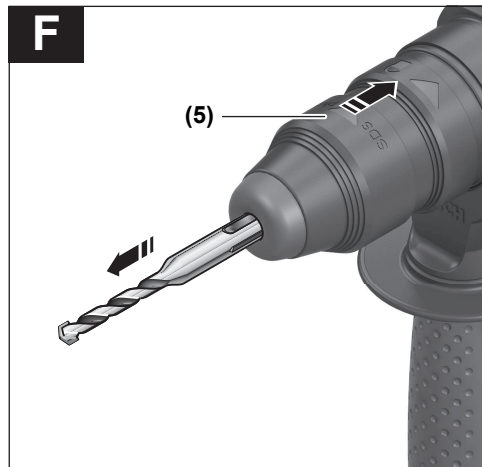
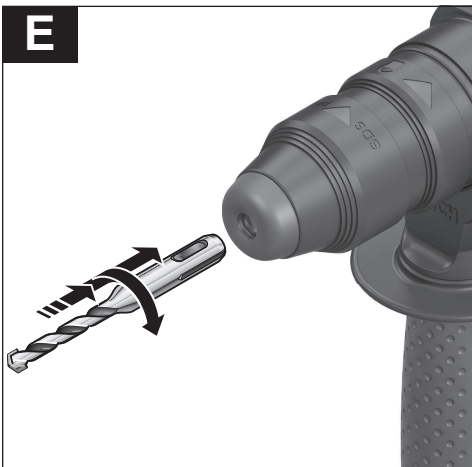
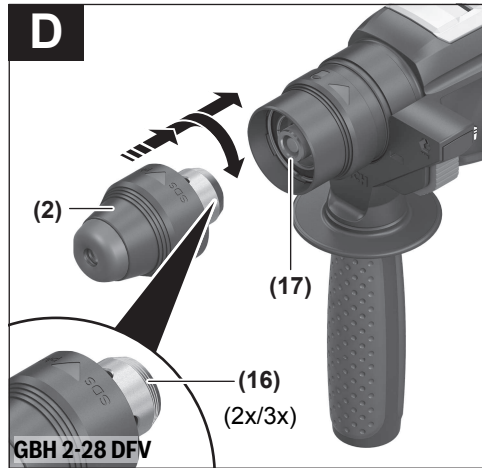
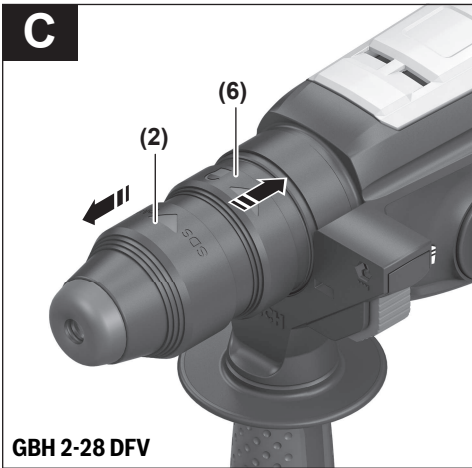
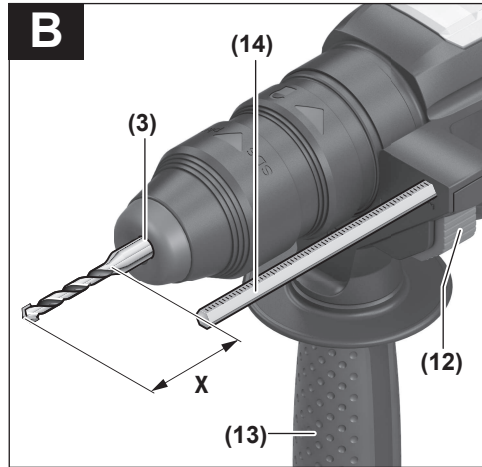
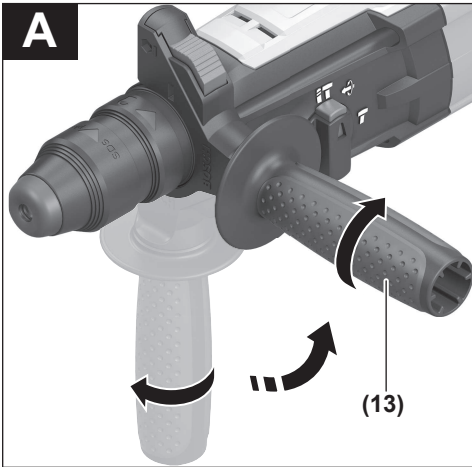

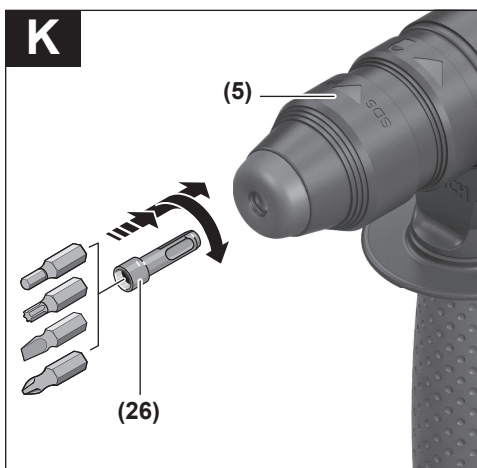
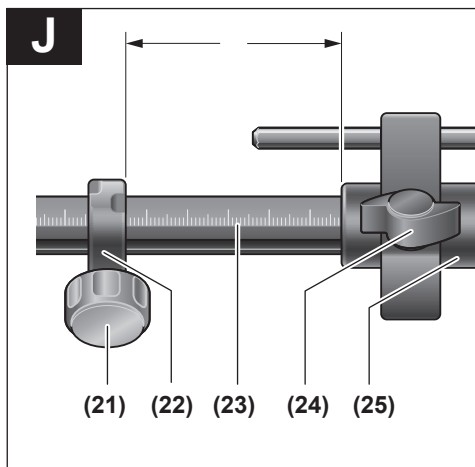
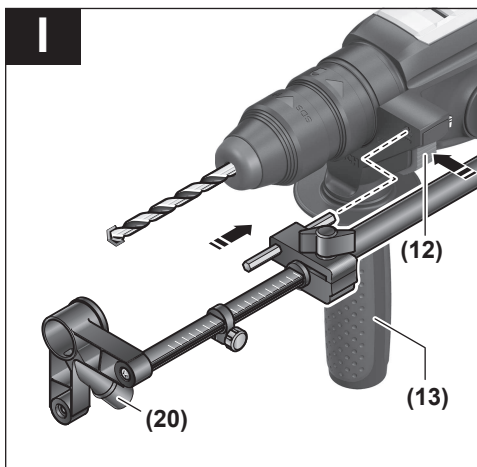
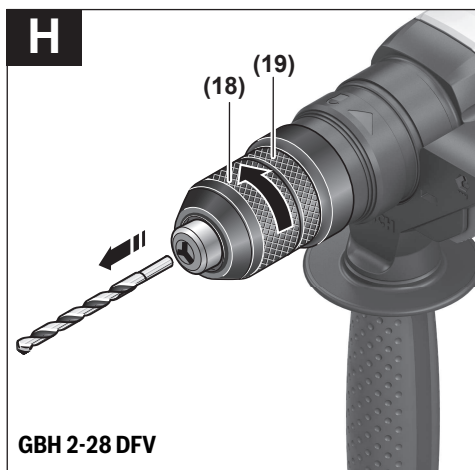
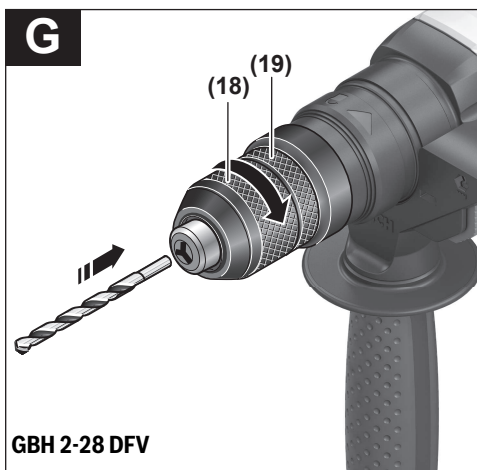

English

Safety instructions

General Power Tool Safety Warnings

⚠ WARNING **Read all safety warnings and all instructions.** Failure to follow the warnings and instructions may result in electric shock, fire and/or serious injury.

Save all warnings and instructions for future reference.

The term "power tool" in the warnings refers to your mains-operated (corded) power tool or battery-operated (cordless) power tool.

Work area safety

- ▶ **Keep work area clean and well lit.** Cluttered or dark areas invite accidents.
- ▶ **Do not operate power tools in explosive atmospheres, such as in the presence of flammable liquids, gases or dust.** Power tools create sparks which may ignite the dust or fumes.
- ▶ **Keep children and bystanders away while operating a power tool.** Distractions can cause you to lose control.

Electrical safety

- ▶ **Power tool plugs must match the outlet. Never modify the plug in any way. Do not use any adapter plugs with earthed (grounded) power tools.** Unmodified plugs and matching outlets will reduce risk of electric shock.
- ▶ **Avoid body contact with earthed or grounded surfaces, such as pipes, radiators, ranges and refrigerators.** There is an increased risk of electric shock if your body is earthed or grounded.
- ▶ **Do not expose power tools to rain or wet conditions.** Water entering a power tool will increase the risk of electric shock.
- ▶ **Do not abuse the cord. Never use the cord for carrying, pulling or unplugging the power tool. Keep cord away from heat, oil, sharp edges or moving parts.** Damaged or entangled cords increase the risk of electric shock.
- ▶ **When operating a power tool outdoors, use an extension cord suitable for outdoor use.** Use of a cord suitable for outdoor use reduces the risk of electric shock..
- ▶ **If operating a power tool in a damp location is unavoidable, use a residual current device (RCD) protected supply.** Use of an RCD reduces the risk of electric shock.

Personal safety

- ▶ **Stay alert, watch what you are doing and use common sense when operating a power tool. Do not use a power tool while you are tired or under the influence of drugs, alcohol or medication.** A moment of inattention while operating power tools may result in serious personal injury.

- ▶ **Use personal protective equipment. Always wear eye protection.** Protective equipment such as dust mask, non-skid safety shoes, hard hat, or hearing protection used for appropriate conditions will reduce personal injuries.
- ▶ **Prevent unintentional starting. Ensure the switch is in the off-position before connecting to power source and/or battery pack, picking up or carrying the tool.** Carrying power tools with your finger on the switch or energising power tools that have the switch on invites accidents.
- ▶ **Remove any adjusting key or wrench before turning the power tool on.** A wrench or a key left attached to a rotating part of the power tool may result in personal injury.
- ▶ **Do not overreach. Keep proper footing and balance at all times.** This enables better control of the power tool in unexpected situations.
- ▶ **Dress properly. Do not wear loose clothing or jewellery. Keep your hair, clothing and gloves away from moving parts.** Loose clothes, jewellery or long hair can be caught in moving parts.
- ▶ **If devices are provided for the connection of dust extraction and collection facilities, ensure these are connected and properly used.** Use of dust collection can reduce dust-related hazards.

Power tool use and care

- ▶ **Do not force the power tool. Use the correct power tool for your application.** The correct power tool will do the job better and safer at the rate for which it was designed.
- ▶ **Do not use the power tool if the switch does not turn it on and off.** Any power tool that cannot be controlled with the switch is dangerous and must be repaired.
- ▶ **Disconnect the plug from the power source and/or the battery pack from the power tool before making any adjustments, changing accessories, or storing power tools.** Such preventive safety measures reduce the risk of starting the power tool accidentally.
- ▶ **Store idle power tools out of the reach of children and do not allow persons unfamiliar with the power tool or these instructions to operate the power tool.** Power tools are dangerous in the hands of untrained users.
- ▶ **Maintain power tools. Check for misalignment or binding of moving parts, breakage of parts and any other condition that may affect the power tool's operation. If damaged, have the power tool repaired before use.** Many accidents are caused by poorly maintained power tools.
- ▶ **Keep cutting tools sharp and clean.** Properly maintained cutting tools with sharp cutting edges are less likely to bind and are easier to control.
- ▶ **Use the power tool, accessories and tool bits etc. in accordance with these instructions, taking into account the working conditions and the work to be performed.**

formed. Use of the power tool for operations different from those intended could result in a hazardous situation.

Service

- ▶ **Have your power tool serviced by a qualified repair person using only identical replacement parts.** This will ensure that the safety of the power tool is maintained.

Hammer and Drill Safety Warnings

Safety instructions for all operations

- ▶ **Wear ear protectors.** Exposure to noise can cause hearing loss.
- ▶ **Use the auxiliary handle(s).** Loss of control can cause personal injury.
- ▶ **Brace the tool properly before use.** This tool produces a high output torque and without properly bracing the tool during operation, loss of control may occur resulting in personal injury.
- ▶ **Hold the power tool by insulated gripping surfaces, when performing an operation where the cutting accessory or fasteners may contact hidden wiring or its own cord.** Cutting accessory or fasteners contacting a "live" wire may make exposed metal parts of the power tool "live" and could give the operator an electric shock.

Safety instructions when using long drill bits

- ▶ **Never operate at higher speed than the maximum speed rating of the drill bit.** At higher speeds, the bit is likely to bend if allowed to rotate freely without contacting the workpiece, resulting in personal injury.
- ▶ **Always start drilling at low speed and with the bit tip in contact with the workpiece.** At higher speeds, the bit is likely to bend if allowed to rotate freely without contacting the workpiece, resulting in personal injury.
- ▶ **Apply pressure only in direct line with the bit and do not apply excessive pressure.** Bits can bend causing breakage or loss of control, resulting in personal injury.

Additional safety information

- ▶ **Use auxiliary handle(s), if supplied with the tool.** Loss of control can cause personal injury.
- ▶ **Hold the power tool firmly with both hands and make sure you have a stable footing.** The power tool can be more securely guided with both hands.
- ▶ **Switch the power tool off immediately if the application tool becomes blocked. Be prepared for high torque reactions which cause kickback.** The application tool becomes blocked when it becomes jammed in the workpiece or when the power tool becomes overloaded.
- ▶ **Secure the workpiece.** A workpiece clamped with clamping devices or in a vice is held more secure than by hand.
- ▶ **Use suitable detectors to determine if utility lines are hidden in the work area or call the local utility company for assistance.** Contact with electric lines can lead to fire and electric shock. Damaging a gas line can lead to

explosion. Penetrating a water line causes property damage or may cause an electric shock.

- ▶ **Always wait until the power tool has come to a complete stop before placing it down.** The application tool can jam and cause you to lose control of the power tool.

Products sold in GB only:

Your product is fitted with an BS 1363/A approved electric plug with internal fuse (ASTA approved to BS 1362).

If the plug is not suitable for your socket outlets, it should be cut off and an appropriate plug fitted in its place by an authorised customer service agent. The replacement plug should have the same fuse rating as the original plug.

The severed plug must be disposed of to avoid a possible shock hazard and should never be inserted into a mains socket elsewhere.

Product Description and Specifications



Read all the safety and general instructions.

Failure to observe the safety and general instructions may result in electric shock, fire and/or serious injury.

Please observe the illustrations at the beginning of this operating manual.

Intended Use

The power tool is intended for hammer drilling in concrete, brick and stone, as well as for light chiselling work. It is also suitable for drilling without impact in wood, metal, ceramic and plastic. Power tools with electronic control and right/left rotation are also suitable for screwdriving.

Product Features

The numbering of the product features refers to the diagram of the power tool on the graphics page.

- (1) Keyless quick-change chuck (**GBH 2-28 DFV**)
- (2) SDS plus quick-change chuck (**GBH 2-28 DFV**)
- (3) SDS plus tool holder
- (4) Dust protection cap
- (5) Locking sleeve
- (6) Locking ring for quick-change chuck (**GBH 2-28 DFV**)
- (7) Rotational direction switch
- (8) Lock-on button for on/off switch
- (9) On/off switch
- (10) Release button for impact/mode selector switch
- (11) Impact/mode selector switch
- (12) Button for depth stop adjustment
- (13) Auxiliary handle (insulated gripping surface)
- (14) Depth stop
- (15) Handle (insulated gripping surface)
- (16) Identification grooves

- (17) Drill chuck holder (GBH 2-28 DFV)
 (18) Front sleeve of the keyless quick-change chuck (GBH 2-28 DFV)
 (19) Retaining ring of the keyless quick-change chuck (GBH 2-28 DFV)
 (20) Saugfix suction opening^{A)}
 (21) Saugfix clamping screw^{A)}
 (22) Saugfix depth stop^{A)}
 (23) Saugfix telescopic tube^{A)}
 (24) Saugfix wing bolt^{A)}
 (25) Saugfix guide tube^{A)}
 (26) Universal holder with SDS plus shank^{A)}
- A) Accessories shown or described are not included with the product as standard. You can find the complete selection of accessories in our accessories range.

Technical Data

Rotary hammer		GBH 2-28 D			GBH 2-28 DV
Article number		3 611 B67 OC. 3 611 B67 OL.	3 611 B67 OK. 3 611 B67 OS.	3 611 B67 1F.	3 611 B67 10.
Quick-change chuck		-	-	-	-
Rated power input	W	850	820	850	820
Impact rate	min ⁻¹	0-5100	0-5100	0-5100	0-5100
Impact energy per stroke according to EPTA-Procedure 05:2016	J	3.2	3.2	3.2	3.2
Rated speed	min ⁻¹	0-1300	0-1300	0-1300	0-1300
Tool holder		SDS plus	SDS plus	SDS plus	SDS plus
Spindle collar diameter	mm	50	50	50	50
Max. drilling diameter					
- Concrete	mm	28	28	28	28
- Masonry (with hollow core bit)	mm	68	68	68	68
- Steel	mm	13	13	13	13
- Wood	mm	30	30	30	30
Weight according to EPTA-Procedure 01:2014	kg	2.9	2.9	2.9	2.9
Protection class		□/II	□/II	□/II	□/II

Rotary hammer		GBH 2-28 DFV	
Article number		3 611 B67 2C. 3 611 B67 2L.	3 611 B67 2K. 3 611 B67 28.
Quick-change chuck		●	●
Rated power input	W	850	820
Impact rate	min ⁻¹	0-5100	0-5100
Impact energy per stroke according to EPTA-Procedure 05:2016	J	3.2	3.2
Rated speed	min ⁻¹	0-1300	0-1300
Tool holder		SDS plus	SDS plus
Spindle collar diameter	mm	50	50
Max. drilling diameter			
- Concrete	mm	28	28

Rotary hammer		GBH 2-28 DFV	
– Masonry (with hollow core bit)	mm	68	68
– Steel	mm	13	13
– Wood	mm	30	30
Weight according to EPTA-Procedure 01:2014	kg	3.1	3.1
Protection class		□ / II	□ / II

The specifications apply to a rated voltage [U] of 230 V. These specifications may vary at different voltages and in country-specific models.

Assembly

- ▶ **Pull the plug out of the socket before carrying out any work on the power tool.**

Auxiliary handle

- ▶ **Do not operate your power tool without the auxiliary handle (13).**

Swivelling the auxiliary handle (see figure A)

You can swivel the auxiliary handle (13) to any angle for a safe work posture that minimises fatigue.

- Turn the lower gripping end of the auxiliary handle (13) anticlockwise and swivel the auxiliary handle (13) into the required position. Then turn the lower gripping end of the auxiliary handle (13) clockwise to retighten it. Make sure that the retaining strap of the auxiliary handle slots into the corresponding groove of the housing.

Setting the drilling depth (see figure B)

You can use the depth stop (14) to set the required drilling depth X.

- Press the button for depth stop adjustment (12) and insert the depth stop into the auxiliary handle (13). The fluting on the depth stop (14) must face downwards.
- Insert the SDS-plus application tool into the SDS-plus tool holder (3) to the stop. Otherwise, the movability of the SDS-plus drilling tool can lead to incorrect adjustment of the drilling depth.
- Pull the depth stop far enough out that the distance between the drill bit tip and the edge of the depth stop corresponds to the required drilling depth X.

Selecting Drill Chucks and Tools

For hammer drilling and chiselling, you will need SDS plus tools, which insert into the SDS plus drill chuck.

For drilling without impact in wood, metal, ceramic and plastic as well as for screwdriving, tools without SDS plus are used (e.g. cylindrical shank drill bits). A keyless chuck is required for such drilling tools.

Removing/inserting the quick-change chuck (GBH 2-28 DFV)

Removing the Quick-Change Chuck (see figure C)

- Pull back on the quick-change chuck locking ring (6), hold it in this position and pull the SDS plus quick-change chuck (2) or the keyless quick-change chuck (1) out from the front.
- Once the quick-change chuck is removed, protect it from dirt.

Inserting the quick-change chuck (see figure D)

- ▶ **Use only model-specific original equipment and pay attention to the number of identification grooves (16). Only quick-change chucks with two or three identification grooves are permitted.** If an unsuitable quick-change chuck is used, the application tool can fall out during operation.
- Before insertion, clean the quick-change chuck and lightly grease the shank.
- Wrap your whole hand around the SDS-plus quick-change chuck (2) or the keyless quick-change chuck (1). Use a turning motion to push the quick-change chuck into the drill chuck holder (17) until you hear it click into place.
- The quick-change chuck is automatically locked. Check that it is locked by pulling on the quick-change chuck.

Changing the Tool

The dust protection cap (4) largely prevents the penetration of drilling dust into the tool holder during operation. When inserting the tool, make sure that the dust protection cap (4) does not become damaged.

- ▶ **Replace a damaged dust protection cap immediately. It is recommended that you have use an after-sales service for this.**

Changing the tool (SDS plus)

Inserting the SDS plus application tool (see figure E)

The SDS-plus drill chuck enables you to change the application tool easily and conveniently without needing to use additional tools.

As a requirement of the system, the SDS-plus application tool can move freely. This causes a certain radial run-out at no-load, which has no effect on the accuracy of the drill hole, as the drill bit centres itself upon drilling.

- **GBH 2-28 DFV:** Insert the SDS plus quick-change chuck (2).
- Clean and lightly grease the shank of the application tool.
- Insert the application tool into the tool holder while turning it until it locks automatically.
- Check that it is locked by pulling on the tool.

Removing SDS-plus application tools (see figure F)

- Push the locking sleeve (5) back and remove the application tool.

Changing the tool (without SDS plus)

(GBH 2-28 DFV)

Inserting the application tool (see figure G)

Note: Application tools that do not have SDS plus must not be used for hammer drilling or chiselling. Tools without SDS plus and their drill chucks are damaged by hammer drilling or chiselling.

- Insert the keyless quick-change chuck (1).
- Hold the retaining ring (19) of the keyless quick-change chuck firmly in place. Open the tool holder by turning the front sleeve (18) until the tool can be inserted. Hold the retaining ring (19) in place and firmly tighten the front sleeve (18) by turning it in the direction of the arrow until you hear it click into place.
- Check that it is seated securely by pulling on the tool.

Note: If the tool holder was unscrewed all the way, a scraping sound may be heard while retightening the tool holder and it may not fully tighten.

In this case, turn the front sleeve (18) in the opposite direction to the arrow by one full turn. This will allow the tool holder to be fully tightened.

- Turn the impact/mode selector switch (11) to the "drilling" position.

Removing the application tool (see figure H)

- Hold the retaining ring (19) of the keyless quick-change chuck firmly in place. Open the tool holder by turning the front sleeve (18) in the direction of the arrow until the tool can be removed.

Dust extraction with the dust extraction attachment (accessory)

Dust/Chip Extraction

The dust from materials such as lead paint, some types of wood, minerals and metal can be harmful to human health. Touching or breathing in this dust can trigger allergic reactions and/or cause respiratory illnesses in the user or in people in the near vicinity.

Certain dusts, such as oak or beech dust, are classified as carcinogenic, especially in conjunction with wood treatment additives (chromate, wood preservative). Materials containing asbestos may only be machined by specialists.

- Use a dust extraction system that is suitable for the material wherever possible.
- Provide good ventilation at the workplace.

- It is advisable to wear a P2 filter class breathing mask. The regulations on the material being machined that apply in the country of use must be observed.

► **Avoid dust accumulation at the workplace.** Dust can easily ignite.

Fitting the dust extraction attachment (see figure I)

For dust extraction, the dust extraction attachment (accessory) is required. When drilling, the dust extraction attachment retracts so that the attachment head is always close to the surface at the drill hole.

- Press the button for depth stop adjustment (12) and remove the depth stop (14). Press the button (12) again and insert the dust extraction attachment into the auxiliary handle (13) from the front.
- Connect an extraction hose (diameter 19 mm, accessory) to the suction opening (20) of the dust extraction attachment.

The dust extractor must be suitable for the material being worked.

When extracting dust that is dry, especially detrimental to health or carcinogenic, use a special dust extractor.

Setting the drilling depth on the dust extraction attachment (see figure J)

You can also set the required drilling depth **X** when the dust extraction attachment is fitted.

- Push the SDS-plus application tool into the SDS-plus tool holder (3) as far as it will go. Otherwise, the movability of the SDS-plus drilling tool can lead to incorrect adjustment of the drilling depth.
- Loosen the wing bolt (24) on the dust extraction attachment.
- Without switching it on, press the power tool firmly against the surface you wish to drill. The SDS-plus application tool must be touching the surface.
- Position the guide tube (25) of the dust extraction attachment in its holder such that the head of the dust extraction attachment rests on the surface to be drilled. Do not slide the guide tube (25) further than necessary over the telescopic tube (23), so that as much as possible of the scale remains visible on the telescopic tube (23).
- Retighten the wing bolt (24). Loosen the clamping screw (21) on the depth stop of the dust extraction attachment.
- Slide the depth stop (22) onto the telescopic tube (23) so that the distance **X** shown in the illustration matches your required drilling depth.
- Tighten the clamping screw (21) in this position.

Operation

- **Products that are only sold in AUS and NZ:** Use a residual current device (RCD) with a nominal residual current of 30 mA or less.

Start-up

- ▶ **Pay attention to the mains voltage. The voltage of the power source must match the voltage specified on the rating plate of the power tool. Power tools marked with 230 V can also be operated with 220 V.**

Setting the Operating Mode

The operating mode of the power tool is selected using the impact/mode selector switch (11).

- To change the operating mode, press the release button (10) and turn the impact/mode selector switch (11) until it clicks into the required position.

Note: Only change the operating mode when the power tool is switched off. Otherwise, the power tool may become damaged.

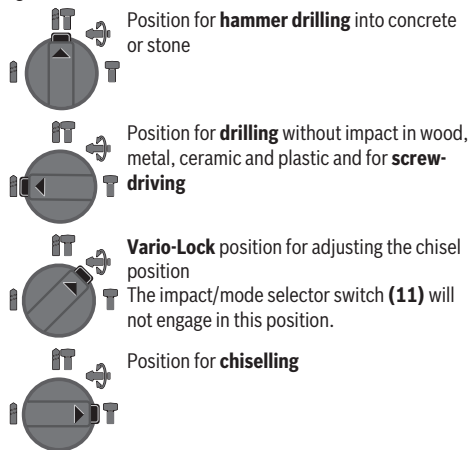

Setting the Rotational Direction

The rotational direction switch (7) is used to change the rotational direction of the power tool. However, this is not possible while the on/off switch (9) is being pressed.

- ▶ **Only operate the rotational direction switch (7) when the power tool is not in use.**

Always set the rotational direction to clockwise rotation for hammer drilling, drilling and chiselling.

- **Rotate clockwise:** Turn the rotational direction switch (7) on both sides until it stops in the ◀ position.
- **Rotate anticlockwise:** Turn the rotational direction switch (7) on both sides until it stops in the ▶ position.

Switching On/Off

- To **switch on** the power tool, press the on/off switch (9).
- To **lock** the on/off switch (9), press and hold it while also pushing the lock-on button (8).
- To **switch off** the power tool, release the on/off switch (9). If the on/off switch (9) is locked, press the switch first and then release it.

Adjusting the Speed/Impact Rate

- Adjust the speed/impact rate of the power tool when it is on by pressing in the on/off switch (9) to varying extents.

Applying light pressure to the on/off switch (9) results in a low rotational speed/impact rate. Applying increasing pressure to the switch increases the speed/impact rate.

Practical Advice

- ▶ **Only apply the power tool to the screw/nut when the tool is switched off.** Rotating tool inserts can slip off.

Changing the chiselling position (Vario-Lock)

You can lock the chisel in 40 different positions, so you can select the optimum working position for each task.

- Insert the chisel into the tool holder.
- Turn the impact/mode selector switch (11) to the "Vario-Lock" position.
- Turn the application tool to the required chisel position.
- Turn the impact/mode selector switch (11) to the "chiselling" position. With this, the tool holder is locked.
- Set the rotational direction for chiselling to clockwise.

Chiselling with lock function

To chisel for extended periods without pressing the on/off switch (9), lock the on/off switch in "chiselling" operating mode.

- To **lock** the power tool, press the on/off switch (9) down fully whilst simultaneously pressing the lock-on switch (8).
- To switch the lock off, press the lock-on button (8) again.

Note: If you switch to a different operating mode while the on/off switch is locked, the power tool will switch off.

Vibration damping

 **Vibration Control** The integrated vibration damping function reduces the generated vibration.

- ▶ **Do not continue to use the power tool if the damping element is damaged.**

Inserting screwdriver bits (see figure K)

- ▶ **Only apply the power tool to the screw/nut when the tool is switched off.** Rotating tool inserts can slip off.

A universal holder (26) with SDS-plus shank (accessory) is required to work with screwdriver bits.

- Clean and lightly grease the insertion end of the shank.
- Insert the universal holder into the tool holder while turning it until it locks automatically.
- Check that it is locked by pulling the universal holder.
- Insert a screwdriver bit in the universal holder. Only use screwdriver bits that fit the screw head.
- To remove the universal holder, slide the locking sleeve (5) backwards and remove the universal holder (26) from the tool holder.

Maintenance and Service

Maintenance and Cleaning

- ▶ **Pull the plug out of the socket before carrying out any work on the power tool.**
- ▶ **To ensure safe and efficient operation, always keep the power tool and the ventilation slots clean.**

In order to avoid safety hazards, if the power supply cord needs to be replaced, this must be done by **Bosch** or by an after-sales service centre that is authorised to repair **Bosch** power tools.

- ▶ **Replace a damaged dust protection cap immediately. It is recommended that you have use an after-sales service for this.**

– Clean the tool holder (3) after each use.

After-Sales Service and Application Service

Our after-sales service responds to your questions concerning maintenance and repair of your product as well as spare parts. You can find explosion drawings and information on spare parts at: **www.bosch-pt.com**

The Bosch product use advice team will be happy to help you with any questions about our products and their accessories.

In all correspondence and spare parts orders, please always include the 10-digit article number given on the nameplate of the product.

Cambodia

Robert Bosch (Cambodia) Co., Ltd
Unit 8BC, GT Tower, 08th Floor, Street 169,
Czechoslovakia Blvd, Sangkat Veal Vong
Khan 7 Makara, Phnom Penh
VAT TIN: 100 169 511
Tel.: +855 23 900 685
Tel.: +855 23 900 660
www.bosch.com.kh

People's Republic of China

China Mainland

Bosch Power Tool (China) Co. Ltd.
Bosch Service Center
567, Bin Kang Road
Bin Kang District
Hangzhou, Zhejiang Province
China 310052
Tel.: (0571) 8887 5566 / 5588
Fax: (0571) 8887 6688 x 5566# / 5588#
E-Mail: bsc.hz@cn.bosch.com
www.bosch-pt.com.cn

HK and Macau Special Administrative Regions

Robert Bosch Co. Ltd.
21st Floor, 625 King's Road
North Point, Hong Kong
Customer Service Hotline: +852 2101 0235
Fax: +852 2590 9762
E-Mail: info@hk.bosch.com
www.bosch-pt.com.hk

India

Bosch Service Center
69, Habibullah Road, (Next to PSBB School), T. Nagar
Chennai-600077
Phone: (044) 64561816

Bosch Service Center
18, Community Center
Phase 1, Mayapuri
New Delhi-110064
Phone: (011) 43166190

Indonesia

PT Robert Bosch
Palma Tower 10th Floor
Jalan RA Kartini II-S Kaveling 6
Pondok Pinang, Kebayoran Lama
Jakarta Selatan 12310
Tel.: (21) 3005-5800
www.bosch-pt.co.id

Malaysia

Robert Bosch Sdn. Bhd.(220975-V) PT/SMY
No. 8A, Jalan 13/6
46200 Petaling Jaya
Selangor
Tel.: (03) 79663194
Toll-Free: 1800 880188
Fax: (03) 79583838
E-Mail: kiathoe.chong@my.bosch.com
www.bosch-pt.com.my

Pakistan

Robert Bosch Middle East FZE – Pakistan Liaison Office
2nd Floor Plaza # 10, CCA Block, DHA Phase 5
Lahore, 54810
Phone: +92(303)4444311
Email: Faisal.Khan@bosch.com

Philippines

Robert Bosch, Inc.
28th Floor Fort Legend Towers,
3rd Avenue corner 31st Street,
Fort Bonifacio, Global City,
1634 Taguig City
Tel.: (632) 8703871
Fax: (632) 8703870
www.bosch-pt.com.ph

Singapore

Powerwell Service Centre Ptd Ltd
Bosch Authorised Service Centre (Power Tools)
4012 Ang Mo Kio Ave 10, #01-02 TECHplace
Singapore 569628
Tel.: 6452 1770
Fax: 6452 1760
E-Mail: ask@powerwellsc.com
www.powerwellsc.com
www.bosch-pt.com.sg

Thailand

Robert Bosch Ltd.
FYI Center Tower 1, 5th Floor,

2525 Rama IV Road, Klongtoei,
Bangkok 10110
Tel.: 02 0128888
Fax: 02 0645802
www.bosch.co.th
Bosch Service – Training Centre
La Salle Tower Ground Floor Unit No.2
10/11 La Salle Moo 16
Srinakharin Road
Bangkaew, Bang Plee
Samutprakarn 10540
Tel.: 02 7587555
Fax: 02 7587525

Vietnam

Branch of Bosch Vietnam Co., Ltd in HCMC
14th floor, Deutsches Haus, 33 Le Duan
Ben Nghe Ward, District 1, Ho Chi Minh City
Tel.: (028) 6258 3690
Fax: (028) 6258 3692 - 6258 3694
Hotline: (028) 6250 8555
Email: tuvankhachhang-pt@vn.bosch.com
www.bosch-pt.com.vn

Bahrain

EA Juffali and Brothers for Technical Equipment Company.
Kingdom of Bahrain, Al Aker - Block 0624 - Road 2403 -
Building 0055D
Phone: +97317704537
Fax: +973177045257
Email: h.berjas@ejb.com.sa

Egypt

RBEG-LLC
22 Kamal Eldin Hussein
Sheraton Heliopolis
11799 Cairo
E-mail: boschegypt.powertools@eg.bosch.com

Iran

Robert Bosch Iran
3rd Floor, No 3, Maadiran Building
Aftab St., Khodami St., Vanak Sq.
Tehran 1994834571
Phone: +9821- 86092057

Iraq

Sahba Technology Group
Al Muthana airport road
Baghdad
Phone Bagdad: +964 (0) 7 901 930366
Phone Dubai: +971 (0) 4 422 1898
Email: duraid@sahbatechnology.com

Jordan

Roots Arabia – Jordan
Al-Hurriyah Street, Al-Muqabalein
Amman 11623, Jordan
P.O. Box: 110068
Tel. : +962 6 4398990
E-mail: bosch@rootsjordan.com

Kuwait

Shuwaikh Industrial Area, Block 1, Plot 16, Street 3rd
P.O. Box 164 – Safat 13002
Phone: +965 - 2496 88 88
Fax: +965 - 2481 08 79
E-mail: josephkr@aaalmutawa.com

Lebanon

Tehini Hana & Co. S.A.R.L.
P.O. Box 90-449
Jdeideh 1202 2040
Dora-Beirut
Phone: +9611255211
Email: service-pt@tehini-hana.com

Libya

El Naser for Workshop Tools
Swanee Road, Alfalah Area
Tripoli
Phone: +218 21 4811184

Oman

Malatan Trading & Contracting LLC
P.O. Box 131, Ruwi, Muscat
Postal Code: 112, Sultanate of Oman
Phone: +968 2479 4035/4089/4901
Mob: +968-91315465
Fax: +968 2479 4058
E-Mail: sudhirkumar@malatan.net

Qatar

International Construction Solutions W L L
P. O. Box 51, Doha
Phone: +974 40065458
Fax: +974 4453 8585
Email: csd@icsdoha.com

Saudi Arabia

Juffali Technical Equipment Co. (JTECO)
P.O.Box: 1049 – Jeddah 21431 – KSA
Jeddah: 00966 (0) 12 692 0770 – Ext 433
Riyadh: 00966 (0) 11 409 3976 – Ext-30/34/39
Dammam: 00966 (0) 13 833 9565
E-mail: M.Zreik@ejb.com.sa

Syria

Dallal Establishment for Power Tools
Damascus. Baramkeh street - lbn Amer street,
Phone: +963112241006 or 009631122414009
Mobile: 00963991141005
Email: rita.dallal@hotmail.com

United Arab Emirates

Central Motors & Equipment,
P.O. Box 26255, Dubai
Dubai: 00971 (0) 4 3090920/3090930
Abu Dhabi: 00971 (0) 2 4017745
Sharjah: 00971 (0) 6 5932777
Al Ain: 00971 (0) 3 7157419
E-Mail: Mallappa.Madari@centralmotors.ae

Yemen

Abu Alrejal Trading Corporation
P.O. Box : 17024 , Zubeiry St.

Sana'a, Yemen
 Tel.: +967-1-20 20 10
 Fax: +967-1-47 19 17
 E-mail: tech-tools@abualrejal.com/yahya@abualrejal.com

Ethiopia

Forever plc
 Kebele 2,754, BP 4806,
 Addis Ababa
 Phone: +251 111 560 600
 Email: foreverplc@ethionet.et

Ghana

Robert Bosch Ghana Limited
 21 Kofi Annan Road Airport Residential Area Accra
 Tel. +233 (0)3027 94616

Kenya

Robert Bosch East Africa Ltd
 Mpaka Road P.O. Box 856
 00606 Nairobi

Nigeria

Robert Bosch Nigeria Ltd.
 52-54 Isaac John Street P.O. Box
 GRA Ikeja – Lagos

Tanzania

Diesel & Autoelectric Service Ltd.
 117 Nyerere Rd., P.O. Box 70839
 Vingunguti 12109, Dar Es Salaam
 Phone: +255 222 861 793/794

Australia, New Zealand and Pacific Islands

Robert Bosch Australia Pty. Ltd.
 Power Tools
 Locked Bag 66
 Clayton South VIC 3169
 Customer Contact Center
 Inside Australia:
 Phone: (01300) 307044
 Fax: (01300) 307045
 Inside New Zealand:
 Phone: (0800) 543353
 Fax: (0800) 428570
 Outside AU and NZ:
 Phone: +61 3 95415555
 www.bosch-pt.com.au
 www.bosch-pt.co.nz

Republic of South Africa Customer service

Hotline: (011) 6519600

Gauteng – BSC Service Centre

35 Roper Street, New Centre
 Johannesburg
 Tel.: (011) 4939375
 Fax: (011) 4930126
 E-Mail: bsctools@icon.co.za

KZN – BSC Service Centre

Unit E, Almar Centre
 143 Crompton Street

Pinetown
 Tel.: (031) 7012120
 Fax: (031) 7012446
 E-Mail: bsc.dur@za.bosch.com

Western Cape – BSC Service Centre

Democracy Way, Prosperity Park
 Milnerton
 Tel.: (021) 5512577
 Fax: (021) 5513223
 E-Mail: bsc@zsd.co.za

Bosch Headquarters

Midrand, Gauteng
 Tel.: (011) 6519600
 Fax: (011) 6519880
 E-Mail: rbsa-hq.pts@za.bosch.com

Armenia, Azerbaijan, Georgia

Robert Bosch Ltd.
 David Agmashenebeli ave. 61
 0102 Tbilisi, Georgia
 Tel. +995322510073
 www.bosch.com

Kyrgyzstan, Mongolia, Tajikistan, Turkmenistan, Uzbekistan

TOO "Robert Bosch" Power Tools, After Sales Service
 Muratbaev Ave., 180
 050012, Almaty, Kazakhstan
 Service Email: service.pt.ka@bosch.com
 Official Website: www.bosch.com, www.bosch-pt.com

Disposal

The power tool, accessories and packaging should be recycled in an environmentally friendly manner.



Do not dispose of power tools along with household waste.

中文

安全规章

电动工具通用安全警告

警告！ 阅读所有警告和所有说明！不遵照以下警告和说明会导致电

击、着火和 / 或严重伤害。

保存所有警告和说明书以备查阅。

在所有下列的警告中术语“电动工具”指市电驱动（有线）电动工具或电池驱动（无线）电动工具。

工作场地的安全

► 保持工作场地清洁和明亮。混乱和黑暗的场地会引发事故。

- ▶ 不要在易爆环境，如有易燃液体、气体或粉尘的环境下操作电动工具。电动工具产生的火花会点燃粉尘或气体。
- ▶ 让儿童和旁观者离开后操作电动工具。注意力不集中会使操作者失去对工具的控制。

电气安全

- ▶ 电动工具插头必须与插座相配。绝不能以任何方式改装插头。需接地的电动工具不能使用任何转换插头。未经改装的插头和相配的插座将减少电击危险。
- ▶ 避免人体接触接地表面，如管道、散热片和冰箱。如果你身体接地会增加电击危险。
- ▶ 不得将电动工具暴露在雨中或潮湿环境中。水进入电动工具将增加电击危险。
- ▶ 不得滥用电线。绝不能用电线搬运、拉动电动工具或拔出其插头。使电线远离热源、油、锐边或运动部件。受损或缠绕的软线会增加电击危险。
- ▶ 当在户外使用电动工具时，使用适合户外使用的外接软线。适合户外使用的软线将减少电击危险。
- ▶ 如果在潮湿环境下操作电动工具是不可避免的，应使用剩余电流动作保护器（RCD）。使用RCD可减小电击危险。

人身安全

- ▶ 保持警觉，当操作电动工具时关注所从事的操作并保持清醒。当你感到疲倦，或在有药物、酒精或治疗反应时，不要操作电动工具。在操作电动工具时瞬间的疏忽会导致严重人身伤害。
- ▶ 使用个人防护装置。始终佩戴护目镜。安全装置，诸如适当条件下使用防尘面具、防滑安全鞋、安全帽、听力防护等装置能减少人身伤害。
- ▶ 防止意外启动。确保开关在连接电源和/或电池盒、拿起或搬运工具时处于关断位置。手指放在已接通电源的开关上或开关处于接通时插入插头可能会导致危险。
- ▶ 在电动工具接通之前，拿掉所有调节钥匙或扳手。遗留在电动工具旋转零件上的扳手或钥匙会导致人身伤害。
- ▶ 手不要伸展得太长。时刻注意立足点和身体平衡。这样在意外情况下能很好地控制电动工具。
- ▶ 着装适当。不要穿宽松衣服或佩戴饰品。让衣服、手套和头发远离运动部件。宽松衣服、配饰或长发可能会卷入运动部件中。
- ▶ 如果提供了与排屑、集尘设备连接用的装置，要确保他们连接完好且使用得当。使用这些装置可减少尘屑引起的危险。

电动工具使用和注意事项

- ▶ 不要滥用电动工具，根据用途使用适当的电动工具。选用适当设计的电动工具会使你工作更有效、更安全。
- ▶ 如果开关不能接通或关断工具电源，则不能使用该电动工具。如果开关不能接通或关断工具电源，则不能使用该电动工具。
- ▶ 在进行任何调节、更换附件或贮存电动工具之前，必须从电源上拔掉插头和/或使电池盒与工具

脱开。这种防护性措施将减少工具意外起动的危险。

- ▶ 将闲置不用的电动工具贮存在儿童所及范围之外，并且不要让不熟悉电动工具或对这些说明不了解的人操作电动工具。电动工具在未经培训的用户手中是危险的。
- ▶ 保养电动工具。检查运动件是否调整到位或卡住，检查零件破损情况和影响电动工具运行的其他状况。如有损坏，电动工具应在使用前修理好。许多事故由维护不良的电动工具引发。
- ▶ 保持切削刀具锋利和清洁。保养良好的有锋利切削刃的刀具不易卡住而且容易控制。
- ▶ 按照使用说明书，考虑作业条件和进行的作业来使用电动工具、附件和工具的刀头等。将电动工具用于那些与其用途不符的操作可能会导致危险。

维修

- ▶ 将你的电动工具送交专业维修人员，使用同样的备件进行修理。这样将确保所维修的电动工具的安全性。

锤类工具的安全警告

适用于全部操作的安全说明

- ▶ 戴好耳罩。暴露在噪声中会引起听力损伤。
- ▶ 使用辅助手柄。失控会造成人身伤害。
- ▶ 工具使用前应得到适当支撑。由于工具输出转矩大，运行时没有适当支撑会失控导致人身伤害。
- ▶ 当在钻削附件可能触及暗线或其自身导线的场合进行操作时，要通过绝缘握持面握持工具。钻削附件碰到带电导线会使工具外露的金属零件带电从而使操作者受到电击。

当使用长钻头时的安全说明

- ▶ 操作时切勿超出钻头的最大额定转速。在较高转速下，如果让钻头在不接触工件的情况下随意旋转，很可能导致其弯折，从而引发人身伤害。
- ▶ 务必以低转速开始钻孔，并让钻头尖端与工件接触。在较高转速下，如果让钻头在不接触工件的情况下随意旋转，很可能导致其弯折，从而引发人身伤害。
- ▶ 施压时务必与钻头成一直线，且不得施加过大压力。若钻头弯折会导致其损坏或失控，从而引发人身伤害。

其它安全规章

- ▶ 使用随工具提供的辅助手柄。操作失手会引起人身伤害。
- ▶ 工作时要使用双手握紧电动工具并确保站稳。使用双手才能够稳定地操作电动工具。
- ▶ 当工具刀头被夹住时，请立即关闭电动工具。以防反作用力矩导致反弹。当电动工具过载或向待加工工件倾斜时，工具刀头就会卡住。
- ▶ 固定好工件。使用固定装置或老虎钳固定工件，会比用手持握工件更牢固。
- ▶ 使用合适的侦测装置侦察隐藏的电线，或者向当地的相关单位寻求支援。接触电线可能引起火灾并让操作者触电。损坏了瓦斯管会引起爆炸。凿

穿水管不仅会造成严重的财物损失，也可能导致触电。

- **等待电动工具完全静止后才能够放下机器。** 机器上的工具可能在工作中被夹住，而令您无法控制电动工具。

产品和性能说明



请阅读所有安全规章和指示。 不遵照以下警告和说明可能导致电击、着火和/或严重伤害。

请注意本使用说明书开头部分的图示。

按照规定使用

本电动工具可以在混凝土、砖墙、和石材上进行震动钻，而且也具备了简单的凿削功能。另外也适合在木材、金属、陶材和塑料上进行无冲击钻孔。有电子调节装置和正反转功能的电动工具也能够拧转螺丝。

插图上的机件

机件的编号和电动工具详解图上的编号一致。

- (1) 快速可换式钻夹头 (GBH 2-28 DFV)
- (2) SDS-plus可换式钻夹头 (GBH 2-28 DFV)
- (3) SDS-plus工具夹头
- (4) 防尘盖
- (5) 锁定套筒

- (6) 可换式钻夹头锁环 (GBH 2-28 DFV)
- (7) 正逆转开关
- (8) 电源开关的锁定按钮
- (9) 电源开关
- (10) 冲击/转动停止开关的解锁按键
- (11) 冲击/转动停止开关
- (12) 深度尺调节键
- (13) 辅助手柄 (绝缘握柄)
- (14) 深度尺
- (15) 手柄 (绝缘握柄)
- (16) 辨识槽线
- (17) 钻夹头刀柄 (GBH 2-28 DFV)
- (18) 快速可换式钻夹头的前套筒 (GBH 2-28 DFV)
- (19) 快速可换式钻夹头的止动环 (GBH 2-28 DFV)
- (20) Saugfix集尘口^{A)}
- (21) Saugfix夹紧螺栓^{A)}
- (22) Saugfix深度尺^{A)}
- (23) Saugfix伸缩管^{A)}
- (24) Saugfix翼形螺栓^{A)}
- (25) Saugfix导管^{A)}
- (26) 带SDS-plus接头柄的通用杆^{A)}

A) 图表或说明上提到的附件，并不包含在基本的供货范围中。本公司的附件清单中有完整的附件供应项目。

技术参数

锤钻		GBH 2-28 D			GBH 2-28 DV
物品代码		3 611 B67 0C. 3 611 B67 0L.	3 611 B67 0K. 3 611 B67 08.	3 611 B67 1F.	3 611 B67 10.
可换式钻夹头		-	-	-	-
额定输入功率	瓦	850	820	850	820
冲击次数	次/分钟	0-5100	0-5100	0-5100	0-5100
单一冲击强度符合EPTA-Procedure 05:2016的规定	J	3.2	3.2	3.2	3.2
额定转速	转/分钟	0-1300	0-1300	0-1300	0-1300
工具夹头		SDS-plus	SDS-plus	SDS-plus	SDS-plus
主轴颈直径	毫米	50	50	50	50
最大钻孔直径					
- 混凝土	毫米	28	28	28	28
- 砖墙 (使用空心钻头)	毫米	68	68	68	68
- 钢	毫米	13	13	13	13
- 木材	毫米	30	30	30	30
重量符合EPTA-Procedure 01:2014	公斤	2.9	2.9	2.9	2.9
保护等级		□/	□/	□/	□/

锤钻		GBH 2-28 DFV	
物品代码		3 611 B67 2C. 3 611 B67 2L.	3 611 B67 2K. 3 611 B67 28.
可换式钻夹头		●	●
额定输入功率	瓦	850	820
冲击次数	次/分钟	0-5100	0-5100
单一冲击强度符合EPTA-Procedure 05:2016的规定	J	3.2	3.2
额定转速	转/分钟	0-1300	0-1300
工具夹头		SDS-plus	SDS-plus
主轴颈直径	毫米	50	50
最大钻孔直径			
- 混凝土	毫米	28	28
- 砖墙 (使用空心钻头)	毫米	68	68
- 钢	毫米	13	13
- 木材	毫米	30	30
重量符合EPTA-Procedure 01:2014	公斤	3.1	3.1
保护等级		□/	□/

本说明书提供的参数是以230 V为依据，于低电压地区，此数据有可能不同。

安装

- ▶ 在电动工具上进行所有操作之前都必须从插座上拔出电源插头。

辅助手柄

- ▶ 操作电动工具时务必使用辅助手柄 (13)。

摆动辅助手柄 (见图片A)

可以任意翻转辅助手柄(13)，由此可在工作中采用安全且不易疲劳的姿势。

- 逆时针旋转辅助手柄(13)的下半部，并将辅助手柄(13)转到需要的位置。然后顺时针重新拧紧辅助手柄(13)的下半部。
注意，辅助手柄的固定套圈必须位于机壳上的固定套圈专属凹槽中。

调整钻孔深度 (参见插图B)

利用限深器(14)可以确定所需的钻深X。

- 按压限深器调节键(12)，并将限深器装入辅助手柄(13)。
限深器(14)的槽纹必须朝下。
- 将SDS-plus工具刀头推入SDS-plus工具夹头(3)，直至极限位置。如果未安装好SDS-plus工具，会影响设定深度的准确性。
- 尽可能地拉出限深器，使钻尖与限深器尖端之间的距离等于所需的钻孔深度X。

选择钻夹头和刀具

在进行锤钻和凿削时，需要已插有SDS-plus钻夹头的SDS-plus刀具。

在木材、金属、陶材和塑料上以及拧转螺丝进行无冲击式钻孔时，可使用不带SDS-plus的刀具（例如圆柱柄钻头）。上述工具必须配合快速夹头一起使用。

拆卸/安装可换式钻夹头

(GBH 2-28 DFV)

取出可换式钻夹头 (参见插图C)

- 向后拉出可换式钻夹头锁环(6)，将其保持在这个位置，然后向前拉下SDS-plus可换式钻夹头(2)或快速可换式钻夹头(1)。
- 保护被拆下的可换式钻夹头，不要弄脏。

插入可换式钻夹头 (参见插图D)

- ▶ 请只使用型号专用的原厂装备，同时注意识别槽的数量(16)。只允许使用带两个或三个识别槽的可换式钻夹头。如果使用与该电动工具不匹配的可换式钻夹头，则工具刀头在运行过程中可能掉落。
- 先清洁夹头然后再安装，必须在接头柄的末端涂抹少许油脂。
- 用整只手握住SDS-plus可换式钻夹头(2)和快速可换式钻夹头(1)。将可换式钻夹头拧入钻夹头刀柄(17)，直至听到清晰的卡止声。
- 此时可换式钻夹头已经自动锁定。拖拉可换式钻夹头检查其是否已经锁定。

更换刀具

防尘盖(4)可以防止工作时钻屑进入工具夹头中。插入刀具时请注意不要损坏防尘盖(4)。

► **损坏的防尘盖必须立即更换。推荐由本公司的售后服务部门进行操作。**

更换刀具 (SDS-plus)

安装SDS-plus工具刀头 (参见插图E)

使用SDS-plus钻夹头可以简单方便地更换工具刀头，无需使用辅助工具。

SDS-plus系统的工具刀头是活动的。因此在空转时会产生径向跳动偏差。该偏差对钻孔的精度没影响，因为钻孔时钻头自定心。

- **GBH 2-28 DFV**: 安装SDS-plus可换式钻夹头(2)。
- 清洁工具刀头的末端并涂抹少许油脂。
- 把工具刀头拧入工具夹头中，必须拧转至工具自动锁定为止。
- 抽拉工具以确定它是否正确锁紧了。

拆卸SDS-plus工具刀头 (见图片F)

- 向后推动锁定套筒(5)，取下工具刀头。

更换刀具 (无SDS-plus)

(GBH 2-28 DFV)

插入工具刀头 (参见插图G)

提示: 切勿使用不带SDS-plus的工具来锤钻或凿削! 没有SDS-plus的工具和夹头会在进行锤钻和凿削时受损。

- 安装快速可换式钻夹头(1)。
- 固定快速可换式钻夹头的止动环(19)。通过转动前套筒(18)打开工具夹头，直至可以插入刀具。固定止动环(19)，然后沿箭头方向用力转动前套筒(18)，直至听到清晰的咔嗒声。
- 以抽拉的方式检查刀具是否装牢。

提示: 如果工具夹头被打开到极限位置，那么在拧紧工具夹头时，就能听见咔嗒声，且工具夹头不能关闭。

在这种情况下逆箭头方向转动前套筒(18)一次。然后，工具夹头才能关闭。

- 将冲击转动停止开关(11)旋转至“钻孔”位置。

取出工具刀头 (参见插图H)

- 固定快速可换式钻夹头的止动环(19)。通过沿箭头方向转动前套筒(18)打开工具夹头，直至能够取出刀具。

带Saugfix (附件) 的集尘装置

吸锯尘/吸锯屑

含铅的颜料以及某些木材、矿物和金属的加工废尘有害健康。机器操作者或者工地附近的人如果接触、吸入这些废尘，可能会有过敏反应或者感染呼吸道疾病。

某些尘埃(例如加工橡木或山毛榉的废尘)可能致癌，特别是和处理木材的添加剂(例如木材的防腐

剂等)结合之后。只有经过专业训练的人才能够加工含石棉的物料。

- 尽可能使用适合物料的吸尘装置。
- 工作场所要保持空气流通。
- 最好佩戴P2滤网等级的口罩。

请留心并遵守贵国和加工物料有关的法规。

► **避免让工作场所堆积过多的尘垢。** 尘垢容易被点燃。

安装集尘装置 (见图片I)

集尘装备需要一个Saugfix (附件) 钻孔时Saugfix会回弹，这样可以确保Saugfix头能够紧贴着表面。

- 按压限深器调节键(12)并拆下限深器(14)。重新按压按钮(12)，并将Saugfix从前面装入辅助手柄(13)。
- 将吸尘管(直径19 mm, 附件) 连接到Saugfix的排气口(20)上。

根据工件的物料选择合适的集尘装置。

抽吸可能危害健康、可能导致癌症或干燥的废尘时，务必使用特殊的集尘装置。

在Saugfix上调整钻孔深度 (见图片J)

也可以在已安装的Saugfix上设定所需的钻孔深度X。

- 将SDS-plus工具刀头推入SDS-plus工具夹头(3)，直至极限位置。如果未安装好SDS-plus工具，会影响设定深度的准确性。
- 松开Saugfix上的翼形螺栓(24)。
- 把尚未开动的电动工具紧紧地顶在待钻孔的位置上。SDS-plus工具刀头必须安装在平面上。
- 将Saugfix导管(25)推入它的支架中，以便让Saugfix头可以保持在待钻孔的平面。推入导管(25)时，尽量不要将它超出伸缩管(23)太多，以此保证伸缩管(23)上的绝大部分刻度能够清晰可见。
- 重新拧紧翼形螺栓(24)。松开Saugfix限深器上的夹紧螺栓(21)。
- 将限深器(22)尽量套到伸缩管(23)上，直至符合图中所示您的所需钻孔深度距离X。
- 在这个位置上拧紧夹紧螺栓(21)。

操作

操作机器

► **注意电源电压!** 电源的电压必须和电动工具铭牌上标示的电压一致。标记为230伏电动工具用220伏的电压可以驱动。

设置运行模式

通过冲击 / 转动停止开关(11)选择电动工具的运行模式。

- 按压用于转换运行模式的解锁按钮(10)，然后转动冲击 / 转动停止开关(11)到所需位置，直至听到卡止声。

提示: 仅可在电动工具关闭的情况下更改运行模式! 否则可能会损坏电动工具。

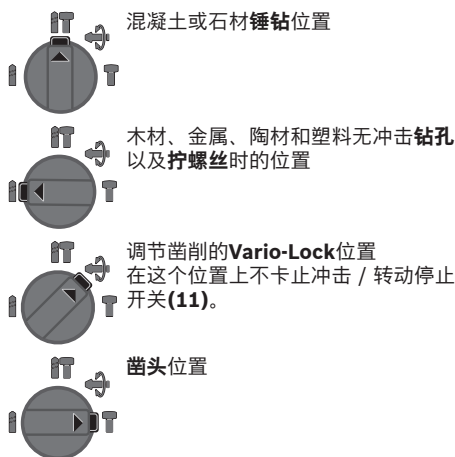

调整旋转方向

通过正逆转开关**(7)**可以更改电动工具的旋转方向。按下起停开关**(9)**后无法更改。

▶ **只能在电动工具静止时操纵正逆转开关**(7)**。**

进行锤钻、正常钻和凿削时，都必须把旋转方向设定为正转。

- **正转**：转动两面正逆转开关**(7)**直至极限位置←

- **逆转**：转动两面正逆转开关**(7)**直至极限位置→

接通/关闭

- 如要**接通**电动工具，按压电源开关**(9)**。

- 如要**锁定**电源开关**(9)**，请按住该开关并另外按压锁定按钮**(8)**。

- 如要**关闭**电动工具，松开电源开关**(9)**。电源开关**(9)**锁住时，先按压，然后再松开。

调整转速 / 冲击次数

- 可无级调节已接通电动工具的转速/冲击次数，视按压电源开关**(9)**的力道程度决定。

以较小的力按压电源开关**(9)**时，转速/冲击次数较低。增强施加在起停开关上的压力，可以提高机器的转速 / 冲击次数。

工作提示

▶ **先关闭电动工具，然后再放置在螺母/螺栓上。**旋转的工具刀头可能会滑开。

改变钻头位置 (Vario-Lock)

您可以将钻头锁定在**40°**的位置。如此可确保最佳的工作姿势。

- 把钻头装入工具夹头中。

- 将冲击 / 转动停止开关**(11)**旋转至“Vario-Lock”位置。

- 把钻头旋转到需要的工作位置上。

- 将冲击 / 转动停止开关**(11)**旋转至“凿削”位置。这样就能锁定工具夹头。

- 进行凿削时必须把旋转方向设定为正转。

带锁定功能的钻头

为了较长时间凿切而不必始终按着电源开关**(9)**，将电源开关锁定在运行模式“凿切”中。

- **锁定时**将电源开关**(9)**按压至极限位置，同时按压锁定键**(8)**。

- 关闭时再次按压锁定键**(8)**。

提示：如果在电源开关已锁定期间切换到另一种运行模式，则电动工具会自动关闭。

减震装置

MW Vibration Control 内置减震装置可减轻出现的振动。

▶ **如果减震装置损坏了，勿继续使用电动工具。**

安装螺丝批嘴 (见图片K)

▶ **先关闭电动工具，然后再放置在螺母/螺栓上。**旋转的工具刀头可能会滑开。

使用螺丝批嘴时，您需要一个带SDS-plus接头柄（附件）的通用连杆**(26)**。

- 清洁接头柄的末端并在接头柄末端涂抹少许油脂。

- 把通用连杆拧入工具夹头中，并让连杆自动锁定。

- 抽拉连杆，检查连杆是否已经正确锁牢。

- 把螺丝批嘴插入通用连杆中。必须使用与螺丝头大小相符的螺丝批嘴。

- 拆卸通用连杆时，向后推锁定套筒**(5)**，然后从工具夹头中拆下通用连杆**(26)**。

维修和服务

保养和清洁

▶ **在电动工具上进行所有操作之前都必须从插座上拔出电源插头。**

▶ **电动工具和通气孔必须随时保持清洁，以确保工作效率和工作安全。**

如果必须更换连接线，务必把这项工作交给**Bosch**或者经授权的**Bosch**电动工具顾客服务执行，以避免危害机器的安全性能。

▶ **必须立即更换损坏的防尘盖。最好委托本公司的顾客服务处换装。**

- 每次使用后请清洁工具夹头**(3)**。

客户服务和应用咨询

本公司顾客服务处负责回答有关本公司产品的修理、维护和备件的问题。备件的展开图纸和信息也可查看：www.bosch-pt.com

博世应用咨询团队乐于就我们的产品及其附件问题提供帮助。

询问和订购备件时，务必提供机器铭牌上标示的10位数物品代码。

香港和澳门特别行政区

罗伯特博世有限公司

香港北角英皇道625号，21楼

客户服务热线：+852 2101 0235

20 | 繁體中文

传真: +852 2590 9762
电子邮件: info@hk.bosch.com
www.bosch-pt.com.hk

中国大陆

博世电动工具(中国)有限公司
中国 浙江省 杭州市
滨江区 滨康路567号
102/1F 服务中心
邮政编码: 310052
电话: (0571)8887 5566 / 5588
传真: (0571)8887 6688 x 5566# / 5588#
电邮: bsc.hz@cn.bosch.com
www.bosch-pt.com.cn

制造商地址:

Robert Bosch Power Tools GmbH
罗伯特·博世电动工具有限公司
70538 Stuttgart / GERMANY
70538 斯图加特 / 德国

处理废弃物

必须以符合环保要求的方式回收再利用电动工具、附件和包装材料。



请勿将电动工具扔到生活垃圾中!

产品中有害物质的名称及含量

部件名称	有害物质					
	铅 (Pb)	汞 (Hg)	镉 (Cd)	六价铬 (Cr ⁺⁶)	多溴联苯 (PBB)	多溴二苯醚 (PBDE)
外壳的金属部分	○	○	○	○	○	○
外壳的非金属部分	○	○	○	○	○	○
机械传动机构	X	○	○	○	○	○
电机组件	X	○	○	○	○	○
控制组件	X	○	○	○	○	○
附件	○	○	○	○	○	○
配件	○	○	○	○	○	○
连接件	X	○	○	○	○	○
电源线* ①	○	○	○	○	○	○
电池系统* ②	X	○	○	○	○	○

本表格依据SJ/T11364 的规定编制。

O: 表示该有害物质在该部件所有均质材料中的含量均在GB/T 26572 规定的限量要求以下。

X: 表示该有害物质至少在该部件的某一均质材料中的含量超出GB/T 26572 规定的限量要求。且目前业界没有成熟的替代方案, 符合欧盟RoHS 指令环保要求。

① 适用于采用电源线连接供电的产品。

② 适用于采用充电电池供电的产品。

产品环保使用期限内的使用条件参见产品说明书。

繁體中文

安全注意事項

電動工具通用安全警告

⚠ 警告

閱讀所有警告和所有說明。不遵照以下警告和說明會導致電

擊、著火和/或嚴重傷害。

保存所有警告和說明書以備查閱。

在所有警告中,「電動工具」此一名詞泛指:以市電驅動的(有線)電動工具或是以電池驅動的(無線)電動工具。

工作場地的安全

- ▶ 保持工作場地清潔和明亮。雜亂和黑暗的場地會引發事故。
- ▶ 不要在易爆環境, 如有易燃液體、氣體或粉塵的環境下操作電動工具。電動工具產生的火花會點燃粉塵或氣體。
- ▶ 讓兒童和旁觀者離開後操作電動工具。注意力不集中會使您失去對工具的控制。

電氣安全

- ▶ **電動工具插頭必須與插座相配。** 絕不能以任何方式改裝插頭。需接地的電動工具不能使用任何轉換插頭。未經改裝的插頭和相配的插座將減少電擊危險。
- ▶ **避免人體接觸接地表面，如管道、散熱片和冰箱。** 如果您身體接地會增加電擊危險。
- ▶ **不得將電動工具暴露在雨中或潮濕環境中。** 水進入電動工具將增加電擊危險。
- ▶ **不得濫用電線。** 絕不能用電線搬運、拉動電動工具或拔出其插頭。將電線遠離熱源、油、銳利邊緣或移動零件。受損或纏繞的軟線會增加電擊危險。
- ▶ **當在戶外使用電動工具時，使用適合戶外使用的延長線。** 適合戶外使用的軟線，將減少電擊危險。
- ▶ **如果在潮濕環境下操作電動工具是不可避免的，應使用剩餘電流動作保護器 (RCD)。** 使用RCD可降低電擊危險。

人身安全

- ▶ **保持警覺，當操作電動工具時關注所從事的操作並保持清醒。** 當您感到疲倦，或在有藥物、酒精或治療反應時，不要操作電動工具。在操作電動工具時瞬間的疏忽會導致嚴重人身傷害。
- ▶ **使用個人防護裝置。** 務必佩戴護目鏡。安全裝置，諸如適當條件下使用防塵面具、防滑安全鞋、安全帽、聽力防護等裝置能減少人身傷害。
- ▶ **防止意外起動。** 確保開關在連接電源和/或電池組、拿起或搬運工具時處於關閉位置。手指放在已接通電源的開關上或開關處於接通時插入插頭可能會導致危險。
- ▶ **在電動工具接通之前，拿掉所有調節鑰匙或扳手。** 遺留在電動工具旋轉零件上的扳手或鑰匙會導致人身傷害。
- ▶ **手不要伸展得太長。** 時刻注意立足點和身體平衡。這樣在意外情況下能很好地控制電動工具。
- ▶ **著裝適當。** 不要穿著寬鬆衣服或佩戴飾品。衣服、手套和頭髮請遠離移動零件。寬鬆衣服、佩飾或長髮可能會捲入移動零件中。
- ▶ **如果有排屑、集塵設備連接用的裝置，請確保其連接完好且使用得當。** 使用這些裝置可減少塵屑引起的危險。

電動工具使用和注意事項

- ▶ **請勿濫用電動工具，** 根據用途使用適當的電動工具。選用適當設計的電動工具會使您工作更有效、更安全。
- ▶ **如果開關不能開啟或關閉工具電源，則不能使用該電動工具。** 不能用開關來控制的電動工具是危險的且必須進行修理。
- ▶ **在進行任何調整、更換附件或貯存電動工具之前，必須從電源上拔掉插頭和/或將電池組拆下。** 這種防護性措施將減少工具意外起動的危險。
- ▶ **將閒置不用的電動工具貯存在兒童所及範圍之外，不得讓不熟悉電動工具或對這些說明不瞭解**

的人操作電動工具。由未經訓練的人員使用電動工具相當危險。

- ▶ **保養電動工具。** 檢查移動零件是否調整到位或卡住，檢查零件破損情況和影響電動工具運轉的其他狀況。如有損壞，電動工具應在使用前修理完成。許多事故由維護不良的電動工具引發。
- ▶ **保持切削刀具鋒利和清潔。** 保養良好的有鋒利切削刃的刀具不易卡住而且容易控制。
- ▶ **按照使用說明書，考慮作業條件和進行的作業來使用電動工具、配件和工具的尖端等。** 將電動工具用於那些與其用途不符的操作可能會導致危險。

檢修

- ▶ **將您的電動工具送交專業維修人員，必須使用同樣的備件進行更換。** 這樣將確保所維修的電動工具的安全性。

鎚鑽安全警告

所有作業的安全說明

- ▶ **請戴上耳罩。** 暴露在噪音下會造成聽力喪失。
- ▶ **使用輔助握把。** 失去控制可能會造成人員受傷。
- ▶ **使用前請確實支撐固定。** 此工具會產生高輸出扭力，操作時若未支撐固定可能會失控並導致人員受傷。
- ▶ **進行作業時，負責進行切割的配件或固定釘可能會碰觸到隱藏的配線或電動工具的電線，請從絕緣握把處拿持電動工具。** 負責進行切割的配件或固定釘若是觸及「導電」電線，可能導致電動工具外露的金屬部件「導電」，進而使操作人員遭受電擊。

使用長鑽頭的安全說明

- ▶ **切勿以超過鑽頭額定最高轉速的速度操作。** 若鑽頭未接觸工件且以超過最高轉速的速度無負載轉動，可能會讓鑽頭彎曲並導致人員受傷。
- ▶ **請務必以低速啟動並將鑽尖確實抵住工件。** 若鑽頭未接觸工件且以超過最高轉速的速度無負載轉動，可能會讓鑽頭彎曲並導致人員受傷。
- ▶ **請沿著鑽頭方向施加適當的壓力，切勿過度施壓。** 鑽頭可能會彎曲並造成斷裂、失控並導致人員受傷。

其他安全注意事項

- ▶ **請使用工具的輔助把手（若有配備）。** 失去控制可能會造成人員受傷。
- ▶ **作業期間請用雙手牢牢握緊電動工具並保持穩固。** 使用雙手才能夠更穩定地操作電動工具。
- ▶ **如果嵌件工具被夾住了，請立刻關閉電動工具的電源。** 請準備好承受反作用力所造成的反彈。電動工具過載時或當它在進行加工的工件內部歪斜時，都會造成嵌件工具被夾住不動。
- ▶ **固定好工件。** 使用固定裝置或老虎鉗固定工件，會比用手持握工件更牢固。
- ▶ **使用合適的偵測裝置偵察隱藏的電線，或者向當地的相關單位尋求支援。** 接觸電線可能引起火災並讓操作者觸電。若損壞瓦斯管會引起爆炸。擊

穿水管不僅會造成嚴重的財物損失，也可能導致觸電。

- ▶ **必須等待電動工具完全靜止後才能將它放下。** 嵌件工具可能卡住而使電動工具失控。

產品和功率描述



請詳讀所有安全注意事項和指示。 如未遵守安全注意事項與指示，可能導致火災、人員遭受電擊及/或重傷。

請留意操作說明書中最前面的圖示。

依規定使用機器

本電動工具適合在混凝土、磚塊及石材進行鎚擊鑽孔，亦適用於簡易型鑿削作業。此外，它同樣也可以用無震動之方式在木材、金屬、陶瓷或塑膠等材質上進行鑽孔加工。具備電子調速和正逆轉功能的電動工具亦可用於拆裝螺栓。

插圖上的機件

機件的編號和電動工具詳解圖上的編號一致。

- (1) 快換夾頭 (GBH 2-28 DFV)
- (2) SDS-plus (四坑系統) 夾頭 (GBH 2-28 DFV)
- (3) SDS-plus (四坑系統) 工具夾座
- (4) 防塵蓋
- (5) 鎖定套筒
- (6) 夾頭鎖止環 (GBH 2-28 DFV)
- (7) 正逆轉開關
- (8) 起停開關鎖止按鈕
- (9) 起停開關
- (10) 鎚擊/旋轉停止開關的解鎖按鈕
- (11) 鎚擊/旋轉停止開關
- (12) 限深擋塊調整按鈕
- (13) 輔助手柄 (絕緣握柄)
- (14) 限深擋塊
- (15) 把手 (絕緣握柄)
- (16) 識別槽
- (17) 夾頭轉接頭 (GBH 2-28 DFV)
- (18) 快換夾頭的前端套筒 (GBH 2-28 DFV)
- (19) 快換夾頭的固定環 (GBH 2-28 DFV)
- (20) Saugfix 裝置的抽吸口^{A)}
- (21) Saugfix 裝置的止付螺栓^{A)}
- (22) Saugfix 裝置的限深擋塊^{A)}
- (23) Saugfix 裝置的伸縮管^{A)}
- (24) Saugfix 裝置的蝶翼螺栓^{A)}
- (25) Saugfix 裝置的導管^{A)}
- (26) 具有 SDS-plus 接頭柄的萬用接桿^{A)}

A) 圖表或說明上提到的配件，並不包含在基本的供貨範圍中。本公司的配件清單中有完整的配件供應項目。

技術性數據

鎚鑽		GBH 2-28 D		GBH 2-28 DV	
產品機號		3 611 B67 0C. 3 611 B67 0L.	3 611 B67 0K. 3 611 B67 08.	3 611 B67 1F.	3 611 B67 10.
夾頭		-	-	-	-
額定輸入功率	W	850	820	850	820
衝擊次數	min ⁻¹	0-5100	0-5100	0-5100	0-5100
單次鎚擊強度符合 EPTA-Procedure 05:2016	J	3.2	3.2	3.2	3.2
額定轉速	次 / 分	0-1300	0-1300	0-1300	0-1300
工具夾座		SDS-plus	SDS-plus	SDS-plus	SDS-plus
軸頭直徑	mm	50	50	50	50
最大鑽孔直徑					
- 混凝土	mm	28	28	28	28
- 砌牆 (使用空心鑽頭)	mm	68	68	68	68
- 鋼材	mm	13	13	13	13
- 木材	mm	30	30	30	30
重量符合 EPTA-Procedure 01:2014	kg	2.9	2.9	2.9	2.9
絕緣等級		□/II	□/II	□/II	□/II

鏈鑽		GBH 2-28 DFV	
產品機號		3 611 B67 2C. 3 611 B67 2L.	3 611 B67 2K. 3 611 B67 28.
夾頭		●	●
額定輸入功率	W	850	820
衝擊次數	min ⁻¹	0-5100	0-5100
單次鏈擊強度符合 EPTA-Procedure 05:2016	J	3.2	3.2
額定轉速	次 / 分	0-1300	0-1300
工具夾座		SDS-plus	SDS-plus
軸頭直徑	mm	50	50
最大鑽孔直徑			
- 混凝土	mm	28	28
- 砌牆 (使用空心鑽頭)	mm	68	68
- 鋼材	mm	13	13
- 木材	mm	30	30
重量符合 EPTA-Procedure 01:2014	kg	3,1	3,1
絕緣等級		□/II	□/II

本說明書提供的數值是以 230 伏特為依據，於使用不同電壓的地區，此數據有可能不同。

安裝

- ▶ 維修電動工具或換裝零、配件之前，務必從插座上拔出插頭。

輔助手柄

- ▶ 操作電動工具時務必使用輔助手柄 (13)。

翻轉輔助手柄 (請參考圖 A)

輔助手柄 (13) 可隨意翻轉，以便採取一個穩固而不容易感到疲勞的工作姿勢。

- 逆時針旋轉輔助手柄 (13) 的下方握把處，以便將輔助手柄 (13) 轉至所需位置。然後再順時針旋轉輔助手柄 (13) 的下方握把處，將它重新鎖緊。注意，輔助手柄的固定套圈必須位於機殼上的固定套圈專屬凹槽中。

調整鑽孔深度 (請參考圖 B)

您可利用限深擋塊 (14) 設定所需鑽孔深度 X。

- 請按壓限深擋塊調整按鈕 (12) 然後將限深擋塊安裝到輔助手柄 (13) 上。限深擋塊 (14) 上的刻紋必須朝下。
- 將 SDS-plus 嵌件工具往 SDS-plus 工具夾座 (3) 推入到底。SDS-plus 工具若未確實裝好，會影響深度設定的準確性。
- 將限深擋塊拉出至，鑽頭尖端與限深擋塊尖端之間的距離等於所需的鑽孔深度 X。

選用夾頭和工具

進行鏈擊鑽孔和鑿削時，必須使用能夠安裝在 SDS-plus 夾頭上的 SDS-plus 工具。

若要以無震動之方式在木材、金屬、陶瓷及塑膠等材質上進行鑽孔，或是想要拆裝螺栓，請使用非 SDS-plus 系統的工具 (例如具有圓柱柄的鑽頭)。上述工具必須配合快速夾頭一起使用。

拆卸/安裝夾頭

(GBH 2-28 DFV)

卸下更換式夾頭 (請參考圖 C)

- 將更換式夾頭鎖止環 (6) 往後拉並讓它固定在這個位置上，然後將 SDS-plus 更換式夾頭 (2) 或快換夾頭 (1) 往前拔下。
- 更換式夾頭取下後需妥善保護，以免受污。

裝上更換式夾頭 (請參考圖 D)

- ▶ 僅可使用機型專用的原廠配件，並同時留意識別槽的數量 (16)。更換式夾頭僅可配有兩個或三個識別槽。若此電動工具未使用合適的更換式夾頭，則嵌件工具可能會在功能運轉期間掉落出來。
- 夾頭需先進行清潔然後才可安裝，必須在接頭柄的插入端塗上少許油脂。
- 用整個手掌環握住 SDS-plus 夾頭 (2) 或快換夾頭 (1)。將夾頭一邊旋轉一邊推至夾頭轉接頭 (17) 上，直到清楚聽見卡上的聲音。
- 此時夾頭已經自動鎖定。但是仍需拉動夾頭，以檢查是否已確實鎖止。

更換工具

防塵蓋 (4) 可阻止鑽孔時所產生的大部份粉塵侵入工具夾座。安裝工具時要小心，請勿損壞防塵蓋 (4)。

- ▶ 防塵蓋若有受損，應立即更換。最好委託本公司的顧客服務處換裝。

更換工具 (SDS-plus)

裝上 SDS-plus 嵌件工具 (請參考圖 E)

夾頭採 SDS-plus (四坑系統) 設計，能夠簡便地更換嵌件工具，無需借助其它輔助工具。

SDS-plus 嵌件工具是活動的，因此在無負載狀態下此類工具會偏心旋轉。開始鑽孔時此工具便會自動置中，因此上述現象並不會影響鑽孔準確度。

- **GBH 2-28 DFV**：直接將 SDS-plus 夾頭 (2) 裝入即可。
- 清潔嵌件工具的插入端並且塗上少許潤滑油脂。
- 把嵌件工具轉進工具夾座中，必須轉至嵌件工具自動鎖定為止。
- 拉動工具以確認它是否已正確鎖止。

取出 SDS-plus 嵌件工具 (請參考圖 F)

- 將鎖定套筒 (5) 往後推，然後便可取出嵌件工具。

更換工具 (非 SDS-plus 系統)

(GBH 2-28 DFV)

安裝嵌件工具 (請參考圖 G)

提示：請勿使用非 SDS-plus 系統的工具進行鎚擊鑽孔或鑿削！非 SDS-plus 系統的工具和夾頭會在進行鎚擊鑽孔和鑿削時受損。

- 請裝上快換夾頭 (1)。
- 必須握好快換夾頭的固定環 (19)，讓它留在原位不動。旋轉前端套筒 (18)，以便工具夾座打開至能夠裝入工具的程度。請將固定環 (19) 握住不動，然後沿箭頭方向用力轉緊前端套筒 (18)，此時必須清楚聽見輾軋聲。
- 透過拉動，確認工具是否已裝牢。

提示：如果工具夾座先前已完全開啟至極限位置，那麼旋轉工具夾座使之閉合時，即使聽見輾軋聲也不代表工具夾座已鎖上。

這時候請您再沿著箭頭的相反方向轉一下前端套筒 (18)。然後工具夾座便能確實閉合。

- 請將鎚擊/旋轉停止開關 (11) 轉至「鑽孔」位置。

取出嵌件工具 (請參考圖 H)

- 必須握好快換夾頭的固定環 (19)，讓它留在原位不動。沿著箭頭方向旋轉前端套筒 (18)，以便將工具夾座打開至能夠取下工具的程度。

搭配 Saugfix 的吸塵裝置 (配件)

吸除廢塵/料屑

含鉛顏料、部分木材種類、礦石和金屬的加工廢塵有害健康。機器操作者或施工現場附近的人員如果接觸、吸入這些廢塵，可能會引發過敏反應或感染呼吸道疾病。

某些塵埃 (例如加工橡木或山毛櫸的廢塵) 可能致癌，特別是與處理木材的添加劑 (例如木材的防腐

劑等) 結合之後。唯有受過專業訓練的人才能夠進行含石棉物料的加工。

- 儘可能使用適合物料的吸塵裝置。
- 工作場所要保持空氣流通。
- 建議佩戴 P2 過濾等級的口罩。

請留意並遵守貴國的物料加工相關法規。

- ▶ **避免讓工作場所堆積過多的塵埃。**塵埃容易被點燃。

安裝吸塵設備 (請參考圖 I)

吸塵設備須使用 Saugfix 裝置 (配件)。鑽孔時，Saugfix 裝置頂部會往後回彈，這樣的設計可以確保 Saugfix 裝置始終緊貼著工件表面。

- 請按壓限深擋塊調整按鈕 (12) 然後取出限深擋塊 (14)。請再次按壓按鈕 (12) 並將 Saugfix 裝置從前面裝入輔助手柄 (13) 中。
- 將吸塵管 (直徑 19 mm, 配件) 連接至 Saugfix 裝置的抽吸口 (20) 上。

根據工件材質選擇合適的吸塵器。

吸集可能危害健康、可能致癌或乾燥的廢塵時，務必使用特殊吸塵器。

在 Saugfix 裝置上調整鑽孔深度 (請參考圖 J)

即使 Saugfix 裝置已裝上，您仍可確認所需的鑽孔深度 X。

- 將 SDS-plus 嵌件工具往 SDS-plus 工具夾頭 (3) 推入到底。如果未裝好工具，會影響深度設定的準確性。
- 鬆開 Saugfix 裝置上的蝶翼螺栓 (24)。
- 把尚未啟動的電動工具緊緊地頂在工件的待鑽孔位置上。SDS-plus 嵌件工具也必須緊貼著工件表面。
- 挪動 Saugfix 裝置導管 (25) 在托架中的位置，使 Saugfix 裝置頂部能完全貼合在待鑽孔的表面上。導管 (25) 推至伸縮管 (23) 之上後，請勿繼續推至超過必要距離，您應要能夠看見伸縮管 (23) 上的大部份刻度。
- 重新鎖緊蝶翼螺栓 (24)。鬆開 Saugfix 裝置限深擋塊上的止付螺栓 (21)。
- 如圖所示，將限深擋塊 (22) 推至伸縮管 (23) 上，使距離 X 等於所需的鑽孔深度。
- 將止付螺栓 (21) 鎖緊在這個位置上。

操作

操作機器

- ▶ **請注意電源電壓！**電源的電壓必須和電動工具銘牌上標示的電壓一致。標示為 230 V 的電動工具亦可接上 220 V 電源。

設定操作模式

您可利用鎚擊/旋轉停止開關 (11) 選擇電動工具的操作模式。

- 若要切換操作模式，請按壓解鎖按鈕 (10) 並將鎚擊/旋轉停止開關 (11) 轉至所需位置，此時應要聽見卡上的聲音。

提示：請務必在電動工具關閉電源時才變更操作模式！否則可能造成電動工具損壞。

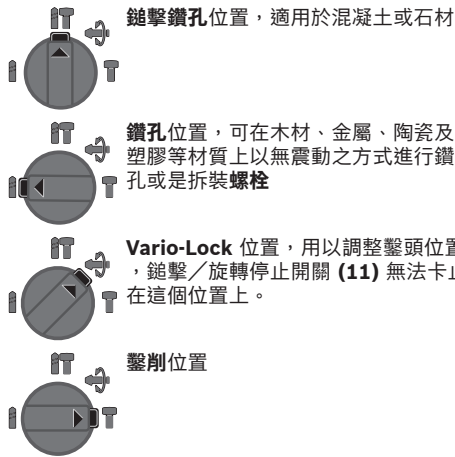

鎚擊鑽孔位置，適用於混凝土或石材

鑽孔位置，可在木材、金屬、陶瓷及塑膠等材質上以無震動之方式進行鑽孔或是拆裝**螺栓**

Vario-Lock 位置，用以調整鑿頭位置，鎚擊／旋轉停止開關 (11) 無法卡止在這個位置上。

鑿削位置

設定旋轉方向

透過正逆轉開關 (7) 即可變更電動工具的旋轉方向。但按下起停開關 (9) 時，將無法這樣做。

▶ **電動工具靜止時，才能操作正逆轉開關 (7)。**

進行鎚擊鑽孔、一般鑽孔及鑿削時，都必須設為正轉。

- **正轉：**將兩邊的正逆轉開關 (7) 都轉到最底位置，對準位置 ←。
- **逆轉：**將兩邊的正逆轉開關 (7) 都轉到最底位置，對準位置 →。

啟動／關閉

- 若要**啟動**電動工具：按下起停開關 (9)。
- 若要**固定**起停開關 (9) 的位置，請將它按住不放並同時按壓鎖止按鈕 (8)。
- 若要**關閉**電動工具，放回起停開關 (9) 即可。起停開關 (9) 的位置若是已被鎖定，請按一下該開關然後放開。

調整轉速／鎚擊次數

- 您可為已啟動的電動工具無段調控轉速／衝擊次數，轉速是由按壓電源開關 (9) 的深度決定。輕按起停開關 (9) 時，轉速／衝擊次數較低。逐漸在開關上加壓，轉速／衝擊次數也會跟著提高。

作業注意事項

- ▶ **電動工具應先停止運轉，然後才放到螺母／螺栓上。**轉動中的嵌件工具可能會滑開。

改變鑿頭位置 (Vario-Lock)

鑿頭可固定在 40 個不同的位置上。藉此，您可採取最佳的工作姿勢。

- 把鑿頭插進工具夾座中。
- 請將鎚擊／旋轉停止開關 (11) 轉至「Vario-Lock」位置。
- 把鑿頭旋轉到所需的工作位置上。

- 請將鎚擊／旋轉停止開關 (11) 轉至「鑿削」位置。工具夾座隨之鎖定。
- 進行鑿削時必須設為正轉。

挖鑿時使用鎖定功能

長時間挖鑿時，可將起停開關的位置鎖定在「挖鑿」操作模式上，於是您就不必一直按著起停開關 (9)。

- 若要**鎖定**起停開關 (9) 的位置，請將它完全按壓到底，然後同時按壓鎖止按鈕 (8)。
- 再按一次鎖止按鈕 (8) 即可關閉此項功能。

提示：如果您在起停開關處於鎖定狀態下時切換至其他操作模式，電動工具將因此關機。

減震裝置

MW Vibration control 內建減震裝置，可減緩震動。

- ▶ **如果減震裝置損壞了，勿繼續使用電動工具。**

裝上螺絲起子工具頭 (請參考圖K)

- ▶ **電動工具應先停止運轉，然後才放到螺母／螺栓上。**轉動中的嵌件工具可能會滑開。

若使用螺絲起子工具頭，須備妥一個具有 SDS-plus 接頭柄的萬用接桿 (26) (配件)。

- 清潔接頭柄的末端並且塗上少許潤滑油脂。
- 把萬用接桿轉進工具夾座中，必須轉至萬用接桿自動鎖定為止。
- 拉動萬用接桿，以確認萬用接桿是否已確實鎖止。
- 把螺絲起子工具頭插入萬用接桿中。必須使用與螺絲頭大小相符的螺絲起子工具頭。
- 若要取下萬用接桿，請將鎖定套筒 (5) 往後推，然後將萬用接桿 (26) 從工具夾座中取出即可。

維修和服務

保養與清潔

- ▶ **維修電動工具或換裝零、配件之前，務必從插座上拔出插頭。**
- ▶ **電動工具和通風口都必須保持清潔，這樣才能夠提高工作品質和安全性。**

如果必須更換連接線，請務必交由 **Bosch** 或者經授權的 **Bosch** 電動工具顧客服務執行，以避免危害機器的安全性能。

- ▶ **防塵蓋若有受損，應立即更換。最好委託本公司的顧客服務處換裝。**

- 每次使用後，請清潔工具夾座 (3)。

顧客服務處和顧客諮詢中心

本公司顧客服務處負責回答有關本公司產品的維修、維護和備用零件的問題。以下的網頁中有分解圖和備用零件相關資料：www.bosch-pt.com 如果對本公司產品及其配件有任何疑問，博世應用諮詢小組很樂意為您提供協助。

當您需要諮詢或訂購備用零件時，請務必提供本產品型號銘牌上 10 位數的產品機號。

中國香港和澳門特別行政區
 羅伯特·博世有限公司
 香港北角英皇道625號21樓
 客戶服務熱線：+852 2101 0235
 傳真：+852 2590 9762
 電子郵件：info@hk.bosch.com
 www.bosch-pt.com.hk

台灣
 台灣羅伯特博世股份有限公司
 建國北路一段90號6樓
 台北市10491
 電話：(02) 7734 2588
 傳真：(02) 2516 1176
 www.bosch-pt.com.tw

製造商地址：
 Robert Bosch Power Tools GmbH
 羅伯特·博世電動工具有限公司
 70538 Stuttgart / GERMANY
 70538 斯圖加特/德國

廢棄物處理

必須以符合環保的方式，回收再利用損壞的機器、配件和廢棄的包裝材料。



不可以把電動工具丟入一般的家庭垃圾中。

設備名稱：鏈鑽，型號：GBH 2-28 D/GBH 2-28 DFV

限用物質及其符號

單元	鉛 (Pb)	汞 (Hg)	鎘 (Cd)	六價鉻 (Cr ⁺⁶)	多溴聯苯 (PBB)	多溴二苯醚 (PBDE)
開關	-	○	○	○	○	○
電容器	○	○	○	○	○	○
馬達	○	○	○	○	○	○
電源線	○	○	○	○	○	○
外殼(塑料)	○	○	○	○	○	○

備考 1. "超出 0.1 wt %" 及 "超出 0.01 wt %" 係指限用物質之百分比含量超出百分比含量基準值。

備考 2. "○" 係指該項限用物質之百分比含量未超出百分比含量基準值。

備考 3. "-" 係指該項限用物質為排除項目。

한국어

안전 수칙

전동공구용 일반 안전수칙

경고

모든 안전수칙과 지시 사항을 상세히 읽고 지켜야 합니다. 다 음의 안전수칙과 지시 사항을 준수하지 않으면 화재 위험이 있으며 감전 혹은 중상을 입을 수 있습니다. **앞으로 참고할 수 있도록 이 안전수칙과 사용 설명서를 잘 보관하십시오.**

다음에서 사용되는 "전동공구"라는 개념은 전원에 연결하여 사용하는 (전선이 있는) 전동 기기나 배터 리를 사용하는 (전선이 없는) 전동 기기를 의미합니 다.

작업장 안전

- ▶ **작업장을 항상 깨끗이 하고 조명을 밝게 하십시오.** 작업장 환경이 어수선하거나 어두우면 사고 를 초래할 수 있습니다.
- ▶ **가연성 유체, 가스 또는 분진이 있어 폭발 위험이 있는 환경에서 전동공구를 사용하지 마십시오.**

전동공구는 분진이나 증기에 점화하는 스파크를 일으킬 수 있습니다.

- ▶ **전동공구를 사용할 때 구경꾼이나 어린이 혹은 다른 사람이 작업장에 접근하지 못하게 하십시오.** 다른 사람이 주의를 산만하게 하면 기기에 대 한 통제력을 잃기 쉽습니다.

전기에 관한 안전

- ▶ **전동공구의 전원 플러그가 전원 콘센트에 잘 맞아야 합니다.** 플러그를 절대 변경시켜서는 안 됩니다. (접지된) 전동공구를 사용할 때 어댑터 플 러그를 사용하지 마십시오. 변형되지 않은 플러 그와 잘 맞는 콘센트를 사용하면 감전의 위험을 줄일 수 있습니다.
- ▶ **파이프 관, 라디에이터, 레인지, 냉장과와 같은 접 지 표면에 몸이 닿지 않도록 하십시오.** 몸에 닿을 경우 감전될 위험이 높습니다.
- ▶ **전동공구를 비에 맞지 않게 하고 습기 있는 곳에 두지 마십시오.** 전동공구에 물이 들어가면 감전 될 위험이 높습니다.
- ▶ **전원 코드를 잘못 사용하는 일이 없도록 하십시오.** 전원 코드를 잡고 전동공구를 운반해서는 안 되며, 콘센트에서 전원 플러그를 뽑을 때 전원 코 드를 잡아 당겨서는 절대로 안 됩니다. 전원 코드 가 열과 오일에 접촉하는 것을 피하고, 날카로운

모서리나 기기의 가동 부위에 닿지 않도록 주의하십시오. 손상되거나 영긴 전원 코드는 감전을 유발할 수 있습니다.

- ▶ 실외에서 전동공구로 작업할 때는 실외용으로 적당한 연장 전원 코드만을 사용하십시오. 실외용 연장 전원 코드를 사용하면 감전의 위험을 줄일 수 있습니다.
- ▶ 전동공구를 습기 찬 곳에서 사용해야 할 경우에는 누전 차단기를 사용하십시오. 누전 차단기를 사용하면 감전 위험을 줄일 수 있습니다.

사용자 안전

- ▶ 신중하게 작업하며, 전동공구를 사용할 때 경솔하게 행동하지 마십시오. 피로한 상태이거나 약물 복용 및 음주한 후에는 전동공구를 사용하지 마십시오. 전동공구를 사용할 때 잠시라도 주의가 산만해지면 충상을 입을 수 있습니다.
- ▶ 작업자 안전을 위한 장치를 사용하십시오. 항상 보안경을 착용하십시오. 전동공구의 종류와 사용에 따라 먼지 보호 마스크, 미끄러지지 않는 안전한 신발, 안전모 또는 귀마개 등의 안전한 복장을 하면 상해의 위험을 줄일 수 있습니다.
- ▶ 실수로 기기가 작동되지 않도록 주의하십시오. 전동공구를 전원에 연결하거나 배터리를 끼우기 전에, 혹은 기기를 들거나 운반하기 전에, 전원 스위치가 꺼져 있는지 다시 확인하십시오. 전동공구를 운반할 때 전원 스위치가 손가락을 대거나 전원 스위치가 켜진 상태에서 전원을 연결하면 사고 위험이 높습니다.
- ▶ 전동공구를 사용하기 전에 조절하는 톨이나 키등을 빼 놓으십시오. 회전하는 부위에 있는 톨이나 키로 인해 상처를 입을 수 있습니다.
- ▶ 자신을 과신하지 마십시오. 불안정한 자세를 피하고 항상 평형을 이룬 상태로 작업하십시오. 안정된 자세와 평형한 상태로 작업해야만 의외의 상황에서도 전동공구를 안전하게 사용할 수 있습니다.
- ▶ 알맞은 작업복을 입으십시오. 헐렁한 복장을 하거나 장신구를 착용하지 마십시오. 머리카락 또는 장갑이 가동하는 기기 부위에 가까이 닿지 않도록 주의하십시오. 헐렁한 복장, 장신구 혹은 긴 머리카락은 가동 부위에 말려 사고를 초래할 수 있습니다.
- ▶ 분진 추출장치나 수거장치의 조립이 가능한 경우, 이 장치가 연결되어 있는지, 제대로 작동이 되는지 확인하십시오. 이러한 분진 추출장치를 사용하면 분진으로 인한 사고 위험을 줄일 수 있습니다.

전동공구의 올바른 사용과 취급

- ▶ 기기를 과부하 상태에서 사용하지 마십시오. 작업할 때 이에 적당한 전동공구를 사용하십시오. 알맞은 전동공구를 사용하면 지정된 성능 한도 내에서 더 효율적으로 안전하게 작업할 수 있습니다.
- ▶ 전원 스위치가 고장 난 전동공구를 사용하지 마십시오. 전원 스위치가 작동되지 않는 전동공구는 위험하므로, 반드시 수리를 해야 합니다.

- ▶ 기기에 세팅을 하거나 액세서리 부품을 교환하거나 혹은 기기를 보관할 때, 항상 전원 콘센트에서 플러그를 미리 빼어 놓으십시오. 이러한 조치는 실수로 전동공구가 작동하게 되는 것을 예방합니다.
- ▶ 사용하지 않는 전동공구는 어린이 손이 닿지 않는 곳에 보관하고, 전동공구 사용에 익숙하지 않거나 이 사용 설명서를 읽지 않은 사람은 기기를 사용해서는 안됩니다. 경험이 없는 사람이 전동공구를 사용하면 위험합니다.
- ▶ 전동공구를 조심스럽게 관리하십시오. 가동 부위가 하자 없이 정상적인 기능을 하는지, 걸리는 부위가 있는지, 혹은 전동공구의 기능에 중요한 부품이 손상되지 않았는지 확인하십시오. 손상된 기기의 부품은 전동공구를 다시 사용하기 전에 반드시 수리를 맡기십시오. 제대로 관리하지 않은 전동공구의 경우 많은 사고를 유발합니다.
- ▶ 절단 공구를 날카롭고 깨끗하게 관리하십시오. 날카로운 절단면이 있고 잘 관리된 절단공구는 걸리는 경우가 드물고 조절하기도 쉽습니다.
- ▶ 전동공구, 액세서리, 장착하는 공구 등을 사용할 때, 이 지시 사항과 특별히 기종 별로 나와있는 사용 방법을 준수하십시오. 이때 작업 조건과 실시하려는 작업 내용을 고려하십시오. 원래 사용 분야가 아닌 다른 작업에 전동공구를 사용할 경우 위험한 상황을 초래할 수 있습니다.

서비스

- ▶ 전동공구 수리는 반드시 전문 인력에게 맡기고, 수리 정비 시 보쉬 순정 부품만을 사용하십시오. 그렇게 함으로써 기기의 안전성을 오래 유지할 수 있습니다.

해머에 대한 안전 경고사항

모든 작업에 대한 안전 수칙

- ▶ 방음 보호구를 착용하십시오. 소음에 노출되면 청력을 상실할 수 있습니다.
- ▶ 보조 손잡이를 사용하십시오. 통제력을 상실하면 부상을 입을 수 있습니다.
- ▶ 사용하기 전에 공구를 잘 받쳐주십시오. 본 공구는 출력 토크가 높기 때문에 작동 중 제대로 받쳐주지 않을 경우 통제력을 잃고 부상을 입을 수 있습니다.
- ▶ 절단용 액세서리 또는 파스너가 숨겨진 배선에 접촉할 가능성이 있는 작업을 수행할 경우, 전동공구의 절단된 손잡이 면만 잡으십시오. 절단용 액세서리 또는 파스너가 "전류가 흐르는" 전선에 접촉되면, 전동공구의 노출된 금속 부품에 "전류가 흐르는" 상태로 만들어 작업자가 감전될 수 있습니다.

긴 드릴 비트를 사용할 경우 안전 수칙

- ▶ 절대 드릴 비트의 최대 정격 속도를 초과한 고속에서 작업하지 마십시오. 고속으로 작업할 경우, 비트가 구부러져 가공물에 닿지 않은 상태에서도 회전하면서 부상을 입을 수 있습니다.
- ▶ 드릴링 시에는 항상 낮은 속도에서 작업을 시작하여 비트의 끝이 가공물에 닿도록 하십시오. 고

속으로 작업할 경우, 비트가 구부러져 가공물에 닿지 않은 상태에서 회전하면서 부상을 입을 수 있습니다.

- ▶ **비트가 작동하는 부분에만 압력을 가하고 과도한 압력을 주지 마십시오.** 비트가 구부러져 파손되거나 통제력을 잃어 부상을 입을 수 있습니다.

추가 안전 경고사항

- ▶ **공구에 보조 손잡이가 함께 공급된 경우, 보조 손잡이를 사용하십시오.** 통제력을 상실하면 부상을 입을 수 있습니다.
- ▶ **전동 공구를 양손으로 꼭 잡고 안전한 자세로 작업하십시오.** 전동공구를 양손으로 잡고 움직이면 더 안전합니다.
- ▶ **툴 홀더에 끼워진 비트가 물리면 즉시 전동공구 스위치를 끄십시오.** 반동을 유발할 수 있는 강한 반동력이 생길 수 있습니다. 전동공구가 과부하된 상태이거나 또는 작업하려는 소재에 걸렸을 경우 비트가 물립니다.
- ▶ **작업물을 잘 고정하십시오.** 고정장치나 기계 바이스에 끼워서 작업하면 손으로 잡는 것보다 더 안전합니다.
- ▶ **보이지 않는 부위에 에너지 배선 및 배관 여부를 확인하려면 적당한 탐지기를 사용하거나 담당 전력 공급회사에 문의하십시오.** 전선에 접하게 되면 화재나 전기 충격을 야기할 수 있습니다. 가스관을 손상시키면 폭발 위험이 있습니다. 수도관을 파손하게 되면 재산 피해를 유발하거나 전기 충격을 야기할 수 있습니다.
- ▶ **전동공구를 내려놓기 전에 기기가 완전히 멈추었는지 확인하십시오.** 삽입공구가 걸리거나 전동공구에 대한 통제가 어려워질 수 있습니다.

제품 및 성능 설명



모든 안전 수칙과 지침을 숙지하십시오. 다음의 안전 수칙과 지침을 준수하지 않으면 화재 위험이 있으며 감전 혹은 중상을 입을 수 있습니다.

사용 설명서 앞 부분에 제시된 그림을 확인하십시오.

규정에 따른 사용

본 전동공구는 콘크리트, 벽돌 및 석재에 임팩트 드릴 작업을 하고 간단한 치출 작업을 하는 데 사용해

제품 사양

해머 드릴	GBH 2-28 D			GBH 2-28 DV
제품 번호	3 611 B67 0C. 3 611 B67 0L.	3 611 B67 0K. 3 611 B67 08.	3 611 B67 1F.	3 611 B67 10.
키레스 척	-	-	-	-
소비 전력	W 850	820	850	820
타격률	min ⁻¹ 0-5100	0-5100	0-5100	0-5100
EPTA-Procedure 05:2016에 따른 스	J 3.2	3.2	3.2	3.2

야 합니다. 또한 목재, 금속, 세라믹 및 플라스틱에서의 타격 없는 드릴 작업에도 적합합니다. 전자 제어 장치와 좌우 회전 기능이 있는 전동공구는 또한 스크류 작업을 하는 데에도 사용이 가능합니다.

제품의 주요 명칭

제품의 주요 명칭에 표기되어 있는 번호는 기기 그림이 나와있는 면을 참고하십시오.

- (1) 순간 교환 키레스 척 (GBH 2-28 DFV)
- (2) SDS-plus 키레스 척 (GBH 2-28 DFV)
- (3) SDS-plus 툴 홀더
- (4) 먼지 보호 캡
- (5) 잠금 슬라이브
- (6) 키레스 척 잠금 링 (GBH 2-28 DFV)
- (7) 회전방향 선택 스위치
- (8) 전원 스위치 잠금 버튼
- (9) 전원 스위치
- (10) 모드 선택 스위치 해제 버튼
- (11) 모드 선택 스위치
- (12) 깊이 조절자 조절용 버튼
- (13) 보조 손잡이 (절연된 손잡이 부위)
- (14) 깊이 조절자
- (15) 손잡이 (절연된 손잡이 부위)
- (16) 식별 홈
- (17) 드릴 척 서포트 (GBH 2-28 DFV)
- (18) 키레스 척 앞쪽 슬라이브 (GBH 2-28 DFV)
- (19) 순간 교환 키레스 척 고정 링 (GBH 2-28 DFV)
- (20) 분진 추출 장치의 흡입 부위 ^{A)}
- (21) 분진 추출 장치의 고정 나사 ^{A)}
- (22) 분진 추출 장치의 깊이 조절자 ^{A)}
- (23) 분진 추출 장치의 텔레스코프 튜브 ^{A)}
- (24) 분진 추출 장치의 날개 나사 ^{A)}
- (25) 분진 추출 장치의 가이드 튜브 ^{A)}
- (26) SDS-plus 어댑터 축이 있는 유니버설 홀더 ^{A)}

A) 도면이나 설명서에 나와있는 액세스리는 표준 공급부품에 속하지 않습니다. 전체 액세스리는 저희 액세스리 프로그램을 참고하십시오.

해머 드릴	GBH 2-28 D			GBH 2-28 DV	
트로크당 타격 에너지					
정격 속도	min ⁻¹	0-1300	0-1300	0-1300	0-1300
툴 홀더		SDS-plus	SDS-plus	SDS-plus	SDS-plus
스핀들 넥 직경	mm	50	50	50	50
최대 드릴 직경					
- 콘크리트	mm	28	28	28	28
- 벽돌(코어 비트 사용 시)	mm	68	68	68	68
- 철재	mm	13	13	13	13
- 목재	mm	30	30	30	30
EPTA-Procedure 01:2014에 따른 중량	kg	2.9	2.9	2.9	2.9
보호 등급		□/II	□/II	□/II	□/II

해머 드릴	GBH 2-28 DFV		
제품 번호		3 611 B67 2C. 3 611 B67 2L.	3 611 B67 2K. 3 611 B67 28.
키레스 척		●	●
소비 전력	W	850	820
타격률	min ⁻¹	0-5100	0-5100
EPTA-Procedure 05:2016에 따른 스트로크당 타격 에너지	J	3.2	3.2
정격 속도	min ⁻¹	0-1300	0-1300
툴 홀더		SDS-plus	SDS-plus
스핀들 넥 직경	mm	50	50
최대 드릴 직경			
- 콘크리트	mm	28	28
- 벽돌(코어 비트 사용 시)	mm	68	68
- 철재	mm	13	13
- 목재	mm	30	30
EPTA-Procedure 01:2014에 따른 중량	kg	3,1	3,1
보호 등급		□/II	□/II

자료는 정격 전압 [U] 230 V를 기준으로 한 것입니다. 전압이 다른 경우 및 국가별 사양에 따라 변동이 있을 수 있습니다.

조립

- ▶ 전동공구를 보수 정비하기 전에 반드시 콘센트에 서 전원 플러그를 빼십시오.

보조 손잡이

- ▶ 반드시 보조 손잡이 (13) 를 장착하여 전동공구를 사용하십시오.

보조 손잡이 조절하기(그림 A 참조)

보조 손잡이 (13) 를 알맞게 젖혀서 안전하고 편안한 작업 자세를 취하십시오.

- 보조 손잡이 (13) 의 아래쪽을 시계 반대 방향으로 돌려 보조 손잡이 (13) 의 방향을 원하는 위치로 전환하십시오. 보조 손잡이 (13) 의 아래쪽을 시계 방향으로 다시 돌려 끼우십시오.

이때 보조 손잡이의 고정 밴드가 하우징에 있는 홈에 제대로 끼여 있는지 확인해야 합니다.

드릴 깊이 조절하기(그림 B 참조)

원하는 천공 깊이 **X**는 깊이 조절자 (14) 로 조절할 수 있습니다.

- 깊이 조절자 조절용 버튼 (12) 을 눌러 깊이 조절자를 보조 손잡이 (13) 에 끼우십시오.
- 깊이 조절자 (14) 에 있는 우툴두툼한 표면이 항상 아래쪽으로 향해 있어야 합니다.
- SDS-plus 비트를 SDS-plus 툴 홀더 (3) 안으로 끝까지 밀어 넣습니다. SDS-plus 비트가 움직이게 되면 천공 깊이를 정확하게 세팅할 수 없게 됩니다.
- 드릴 비트의 끝과 깊이 조절자의 끝 부위의 간격이 원하는 천공 깊이 **X**가 될 때까지 깊이 조절자를 잡아 당깁니다.

드릴 척과 비트 선택하기

해머 드릴 작업이나 치출 작업을 하려면 기기의 SDS-plus 드릴 척에 삽입되는 SDS-plus 비트를 사용해야 합니다.

목재, 금속, 세라믹 그리고 플라스틱에 타격없이 드릴 작업을 하거나 스크류 작업을 하려면 SDS-plus 가 아닌 비트를 사용해야 합니다(예: 실린더 생크 타입 드릴 비트). 이러한 비트를 사용하려면 순간 교환 키레스 척이 필요합니다.

키레스 척 탈착하기/장착하기

(GBH 2-28 DFV)

키레스 척 탈착하기(그림 C 참조)

- 키레스 척 잠금 링 (6) 을 뒤로 당기고, 이 위치를 유지한 상태에서 SDS-plus 키레스 척 (2) 또는 교환 가능한 키레스 척 (1) 을 앞으로 당겨 빼냅니다.
- 키레스 척을 탈착한 후 더러워지지 않도록 하십시오.

키레스 척 장착하기(그림 D 참조)

- ▶ 반드시 기기 모델 고유의 순정품만 사용하고 이때 식별 홈 (16) 의 개수를 확인해 보십시오. 식별 홈이 두 개 또는 세 개가 있는 키레스 척만 사용해야 합니다. 본 전동공구에 적합하지 않은 키레스 척을 사용한 경우, 비트가 작동 중에 빠질 수 있습니다.
- 키레스 척을 끼우기 전에 깨끗이 닦고 끼워지는 부분에 약간 그리스를 바릅니다.
- SDS-plus 키레스 척 (2) 또는 순간 교환 키레스 척 (1) 을 양손으로 붙잡으십시오. 확실하게 잠기는 소리가 들릴 때까지 키레스 척을 돌리면서 드릴 척 서포트 (17) 쪽으로 미십시오.
- 키레스 척은 자동으로 잠깁니다. 키레스 척을 당겨보아 제대로 잠겼는지 확인해 보십시오.

툴 교환

먼지 보호 캡 (4) 은 작업하는 동안 먼지가 툴 홀더 안으로 들어가는 것을 방지해 줍니다. 비트 장착 시,

먼지 보호 캡 (4) 이 손상되지 않도록 주의하십시오.

▶ 손상된 먼지 보호 캡은 즉시 교환하십시오. 고객 서비스 센터에서 교환하는 것을 권장합니다.

툴 교환(SDS-plus)

SDS-plus 비트 장착하기(그림 E 참조)

SDS-plus 드릴 척을 사용하면 별도의 공구를 사용하지 않고도 간단하고 쉽게 비트를 교환할 수 있습니다.

SDS-plus 비트는 시스템상 충분히 움직이게 되어 있습니다. 그래서 공전 상태에서 편심 현상이 생기지만 드릴작업 시에는 다시 저절로 중심을 잡습니다. 이는 작업의 정확성에 어떠한 영향도 미치지 않습니다.

- GBH 2-28 DFV: SDS-plus 키레스 척 (2) 을 끼우십시오.
- 끼우려는 비트의 끝 부분을 깨끗이 닦고 그리스를 바릅니다.
- 비트가 자동으로 잠길 때까지 툴 홀더 안으로 돌려 끼우십시오.
- 비트를 잡아당겨 보면서 제대로 끼워졌는지 확인해 보십시오.

SDS-plus 비트 탈착하기(그림 F 참조)

- 잠금 슬리브 (5) 를 뒤쪽으로 민 후, 비트를 분리합니다.

(SDS-plus가 아닌) 툴 교환

(GBH 2-28 DFV)

비트 장착하기(그림 G 참조)

지침: 해머 드릴 작업이나 치출 작업을 할 때 SDS-plus가 아닌 비트를 사용하지 마십시오! SDS-plus가 아닌 비트와 그 드릴 척이 해머 드릴 작업과 치출 작업으로 인해 손상됩니다.

- 순간 교환 키레스 척 (1) 을 삽입하십시오.
- 교환 가능한 키레스 척의 고정 링 (19) 을 꼭 잡으십시오. 공구가 장착될 때까지 앞쪽 슬리브 (18) 를 돌려 공구 어댑터를 푸십시오. 고정 링 (19) 을 꼭 붙잡고 잠기는 소리가 확실하게 들릴 때까지 앞쪽 슬리브 (18) 를 세게 화살표 방향으로 돌리십시오.
- 비트를 당겨보면서 제대로 끼워졌는지 확인해 보십시오.

지침: 툴 홀더가 스톱 위치까지 열렸으면, 툴 홀더를 돌려 잠글 때 끼워지는 소리가 들리며 툴 홀더는 잠기지 않을 수 있습니다.

이 경우 앞쪽 슬리브 (18) 를 화살표 방향으로 돌리십시오. 그 이후 툴 홀더를 잠글 수 있습니다.

- 모드 선택 스위치 (11) 를 “드릴 작업” 위치로 돌리십시오.

비트 분리하기(그림 H 참조)

- 교환 가능한 키레스 척의 고정 링 (19) 을 꼭 잡으십시오. 공구가 분리 때까지 앞쪽 슬리브 (18) 를 화살표 방향으로 돌려 공구 어댑터를 푸십시오.

분진 추출장치(엑세서리)를 사용한 분진 처리

분진 및 톱밥 추출장치

납 성분을 포함한 페인트나 몇몇 나무 종류, 또는 광물 성분 그리고 철과 같은 재료의 분진은 건강을 해칠 수 있습니다. 이 분진을 만지거나 호흡할 경우, 사용자나 주변 사람들이 알레르기 반응이나 호흡기 장애를 일으킬 수 있습니다.

떡갈나무나 너도밤나무와 같은 특정한 분진은 암을 유발시키며, 특히 목재 처리용으로 사용되는 부가 원료 (크로마트, 목재 보호제)와 혼합되면 암을 유발시키게 됩니다. 석면 성분을 포함한 재료는 전문가만 작업할 수 있습니다.

- 가능하면 작업을 소재에 적당한 분진 추출장치를 사용하십시오.

- 작업장의 통풍이 잘 되도록 하십시오.

- 필터등급 P2가 장착된 호흡 마스크를 사용하십시오.

작업용 재료에 관해 국가가 지정한 규정을 고려하십시오.

▶ **작업장에 분진이 쌓이지 않도록 하십시오.** 분진이 쉽게 발화할 수 있습니다.

분진 추출장치 조립하기(그림 I 참조)

분진 추출을 위해 분진 추출장치(엑세서리)가 필요합니다. 드릴 작업 시 분진 추출장치는 수축되어 분진 추출장치 헤드가 항상 모재에 바짝 붙어 있게 합니다.

- 깊이 조절자 조절용 버튼 (12) 을 눌러 깊이 조절자 (14) 를 빼내십시오. 버튼 (12) 을 다시 눌러 분진 추출장치를 앞쪽부터 보조 손잡이 (13) 에 끼우십시오.

- 흡입 호스(직경 19 mm, 엑세서리)를 분진 추출 장치의 흡입 부위 (20) 에 연결하십시오.

진공 청소기는 작업하는 소재에 적당한 것이어야 합니다.

특히 건강에 유해한 발암성 혹은 건조한 분진을 처리해야 할 경우에는 특수한 청소기를 사용해야 합니다.

분진 추출장치의 드릴 깊이를 조절하기(그림 J 참조)

분진 추출장치가 장착된 상태에서도 원하는 드릴 깊이를 X 를 정할 수 있습니다.

- SDS-plus 비트를 SDS-plus 톱 홀더 (3) 안으로 끝까지 밀어 넣습니다. SDS-plus 비트가 움직이게 되면 천공 깊이를 정확하게 세팅할 수 없게 됩니다.

- 분진 추출장치에서 날개 나사 (24) 를 푸십시오.

- 전동공구의 스위치를 켜지 않은 상태로 드릴작업을 하려는 부위에 바짝 닿습니다. 이때 SDS-plus 비트가 표면에 닿아야 합니다.

- 분진 추출장치의 가이드 튜브 (25) 를 분진 추출 장치 헤드가 드릴 작업해야 할 표면에 놓이도록 고정부에서 미십시오. 가이드 튜브 (25) 를 필요한 만큼만 텔레스코프 튜브 (23) 위쪽으로 밀어 텔레스코프 튜브 (23) 에 있는 눈금이 최대한 많이 보이도록 하십시오.

- 날개 나사 (24) 를 다시 체결하십시오. 분진 추출 장치의 깊이 조절자에서 고정 나사 (21) 를 푸십시오.

- 깊이 조절자 (22) 를 텔레스코프 튜브 (23) 에서 밀어 그림에 표시된 간격 X 가 원하는 드릴 깊이와 일치되게 하십시오.

- 이 위치에서 고정 나사 (21) 를 조이십시오.

작동

기계 시동

▶ **전원의 전압에 유의하십시오! 공급되는 전원의 전압은 전동공구의 명판에 표기된 전압과 동일해야 합니다. 230 V 로 표시된 전동공구는 220 V 에서도 작동이 가능합니다.**

작동 모드 설정하기

모드 선택 스위치 (11) 를 이용하여 전동공구의 작동 모드를 선택하십시오.

- 작동 모드를 변경하려면 해제 버튼 (10) 을 누른 상태에서 모드 선택 스위치 (11) 가 맞물려 잠기는 소리가 날 때까지 원하는 위치로 돌립니다.

지침: 작동 모드는 전동공구가 꺼진 상태에서만 변경하십시오! 그렇게 하지 않으면 전동공구가 손상될 수 있습니다.

콘크리트 또는 석재에서의 **해머 드릴** 작업 위치



목재, 금속, 세라믹, 플라스틱에서 타격이 없는 단순 **드릴 작업 및 스크류** 작업 위치



치출 위치 조절을 위한 **Vario-Lock** 위치



모드 선택 스위치 (11) 는 이 위치에서 잠기지 않습니다.



치출 작업 위치

회전방향 설정하기

회전방향 선택 스위치 (7) 를 이용해 전동공구의 회전 방향을 변경할 수 있습니다. 전원 스위치 (9) 가 눌린 상태에서는 변경할 수 없습니다.

▶ **전동공구가 정지된 상태에서만 회전방향 선택 스위치 (7) 를 작동하십시오.**

해머 드릴작업, 드릴작업 혹은 치출작업을 하려면 회전방향이 반드시 우회전에 있어야 합니다.

- **우회전:** 회전방향 선택 스위치 (7) 를 양쪽에 있는 스톱퍼까지 ◀ 위치로 미십시오.

- **좌회전:** 회전방향 선택 스위치 (7) 를 양쪽에 있는 스톱퍼까지 ▶ 위치로 미십시오.

전원 스위치 작동

- 전동공구의 전원을 끄려면 전원 스위치를 (9) 누르십시오.
- 전원 스위치 (9) 를 누른 상태로 고정하려면 잠금 버튼 (8) 을 위로 누릅니다.
- 전동공구의 전원을 끄려면 전원 스위치 (9) 에서 손을 떼십시오. 전원 스위치 (9) 가 잠긴 상태에서는 먼저 전원 스위치를 눌렀다가 손을 떼십시오.

속도/타격을 조절하기

- 전원이 켜진 전동공구의 속도/타격률은 전원 스위치 (9) 를 움직이는 정도에 따라 자유롭게 조절하십시오.
- 전원 스위치 (9) 쪽으로 약간만 밀면 낮은 속도/타격률이 설정됩니다. 좀 더 세게 누르면 속도/타격률이 증가합니다.

사용 방법

- ▶ 전동공구의 스위치가 꺼진 상태에서만 볼트/너트에 대십시오. 회전하는 드릴 비트가 미끄러질 수 있습니다.

치출 위치 바꾸기(Vario-Lock)

- 40 위치에서 치출을 고정시킬 수 있습니다. 이를 통해 각각 적의 작업 위치를 선정할 수 있습니다.
- 치출을 톨 홀더에 끼웁니다.
 - 모드 선택 스위치 (11) 를 “Vario-Lock” 위치로 돌리십시오.
 - 원하는 치출 위치로 비트를 돌리십시오.
 - 타격/회전 모드 스위치 (11) 을 “치출 작업” 위치로 돌리십시오. 그러면 톨 홀더가 고정됩니다.
 - 치출작업을 하려면 회전방향은 오른쪽으로 맞추십시오.

잠금 기능을 이용한 치출 작업

- 전원 스위치 (9) 를 계속 누르지 않고 더 오랜 시간 치출 작업을 하려면, 전원 스위치를 “치출 작업” 작동 모드에서 전원 스위치를 잠긴 상태로 고정하십시오.
- 전원 스위치 (9) 를 고정하려면 전원 스위치를 끝까지 누른 상태에서 잠금 버튼 (8) 을 누르십시오.
 - 전원을 끄려면 잠금 버튼 (8) 을 다시 누르십시오.

지침: 전원 스위치가 잠겨 있는 동안 작동 모드를 전환하면, 전동공구가 꺼집니다.

진동 감소장치

 진동 감소장치가 내장되어 있어 진동 발생이 줄어듭니다.

- ▶ 진동 감소장치가 손상된 경우 전동공구를 계속 사용하지 마십시오.

스크류 드라이버 비트 장착하기(그림 K 참조)

- ▶ 전동공구의 스위치가 꺼진 상태에서만 볼트/너트에 대십시오. 회전하는 드릴 비트가 미끄러질 수 있습니다.

스크류 드라이버 비트를 사용하려면 SDS-plus 어댑터 축이 있는 유니버설 홀더 (26) (액세서리)가 필요합니다.

- 어댑터 축의 끼워지는 부분을 깨끗이 닦고 약간 그리스를 바릅니다.
- 유니버설 홀더가 저절로 잠길 때까지 톨 홀더 안으로 돌리면서 끼웁니다.
- 유니버설 홀더를 당겨보아 제대로 잠겼는지 확인하십시오.
- 스크류 드라이버 비트 한 개를 유니버설 홀더에 끼웁니다. 스크류 헤드에 맞는 스크류 드라이버 비트만을 사용하십시오.
- 유니버설 홀더를 분리하려면 잠금 슬리브 (5) 를 뒤쪽으로 밀고 유니버설 홀더 (26) 를 톨 홀더에서 분리하십시오.

보수 정비 및 서비스

보수 정비 및 유지

- ▶ 전동공구를 보수 정비하기 전에 반드시 콘센트에서 전원 플러그를 빼십시오.
- ▶ 안전하고 올바른 작동을 위하여 전동공구와 전동공구의 통풍구를 항상 깨끗이 하십시오.

연결 코드를 교환해야 할 경우 안전을 기하기 위해 Bosch 또는 Bosch 지정 전동공구 서비스 센터에 맡겨야 합니다.

- ▶ 손상된 먼지 보호 캡은 즉시 교환하십시오. 고객 서비스 센터에서 교환하는 것을 권장합니다.
- 톨 홀더 (3) 를 사용한 후에는 항상 깨끗이 닦아 주십시오.

AS 센터 및 사용 문의

AS 센터에서는 귀하 제품의 수리 및 보수정비, 그리고 부품에 관한 문의를 받고 있습니다. 대체 부품에 관한 분해 조립도 및 정보는 인터넷에서도 찾아볼 수 있습니다 - www.bosch-pt.com

보쉬 사용 문의 팀에서는 보쉬의 제품 및 해당 액세서리에 관한 질문에 기꺼이 답변 드릴 것입니다.

문의나 대체 부품 주문 시에는 반드시 제품 네임 플레이트에 있는 10자리의 부품번호를 알려 주십시오.

콜센터
080-955-0909

처리

기기와 액세서리 및 포장 등은 환경 친화적인 방법으로 재활용 수 있도록 분류하십시오.



전동공구를 가정용 쓰레기로 처리하지 마십시오!

ไทย

คำเตือนเพื่อความปลอดภัย

คำเตือนเพื่อความปลอดภัยทั่วไปในการใช้เครื่องมือไฟฟ้า

คำเตือน อ่านคำเตือนเพื่อความปลอดภัยและคำสั่งทั้งหมด การไม่ปฏิบัติตามคำเตือนและคำสั่งอาจเป็นสาเหตุให้ถูกไฟฟ้าดูด เกิดไฟไหม้ และ/หรือได้รับบาดเจ็บอย่างร้ายแรง

เก็บรักษาคำเตือนและคำสั่งทั้งหมดสำหรับเปิดอ่านในภายหลัง

คำว่า "เครื่องมือไฟฟ้า" ในคำเตือนหมายถึง เครื่องมือไฟฟ้าของท่านที่ทำงานด้วยพลังงานไฟฟ้าจากแหล่งจ่ายไฟหลัก (มีสายไฟฟ้า) และเครื่องมือไฟฟ้าที่ทำงานด้วยพลังงานไฟฟ้าจากแบตเตอรี่ (ไร้สาย)

ความปลอดภัยในสถานที่ทำงาน

- ▶ **รักษาสถานที่ทำงานให้สะอาดและมีไฟส่องสว่างดี** สถานที่ที่มีมืดหรือรกรุงรังนำมาซึ่งอุบัติเหตุ
- ▶ **อย่าใช้เครื่องมือไฟฟ้าทำงานในสภาพบรรยากาศที่จุดติดไฟได้** เช่น ในที่มีมีของเหลวไวไฟ ก๊าซ หรือฝุ่น เมื่อใช้เครื่องมือไฟฟ้าจะเกิดประกายไฟซึ่งอาจจุดฝุ่นหรือไอให้ลุกเป็นไฟได้
- ▶ **ขณะใช้เครื่องมือไฟฟ้าทำงาน ต้องกันเด็กและผู้ยืนดูให้ออกห่าง**
การหันเหความสนใจอาจทำให้ท่านขาดการควบคุมเครื่องได้

ความปลอดภัยเกี่ยวกับไฟฟ้า

- ▶ **ปลั๊กของเครื่องมือไฟฟ้าต้องเหมาะสมพอดีกับเต้าเสียบ** อย่าตัดแปลงปลั๊กไม่ว่าในลักษณะใดๆ อย่างเด็ดขาด อย่าใช้ปลั๊กพ่วงต่อใดๆ กับเครื่องมือไฟฟ้าที่มีสายดิน ปลั๊กที่ไม่ตัดแปลงและเต้าเสียบที่เข้ากันช่วยลดความเสี่ยงจากการถูกไฟฟ้าดูด
- ▶ **หลีกเลี่ยงอย่าให้ร่างกายสัมผัสกับพื้นผิวที่ต่อสายดินหรือลงกราวด์ไว้** เช่น ท่อ เครื่องทำความร้อน เตา และตู้เย็น จะเสี่ยงอันตรายจากการถูกไฟฟ้าดูดมากขึ้นหากกระแสไฟฟ้าวิ่งผ่านร่างกายของท่านลงดิน
- ▶ **อย่าให้เครื่องมือไฟฟ้าถูกฝนหรืออยู่ในสภาพเปียกชื้น** หากน้ำเข้าในเครื่องมือไฟฟ้า จะเพิ่มความเสี่ยงจากการถูกไฟฟ้าดูด

- ▶ **อย่าใช้สายไฟฟ้าในทางที่ผิด อย่าใช้สายไฟฟ้าเพื่อยก ดึง หรือถอดปลั๊กเครื่องมือไฟฟ้า** กันสายไฟฟ้าออกห่างจากความร้อน น้ำมัน ขอบแหลมคม หรือชิ้นส่วนที่เคลื่อนที่ สายไฟฟ้าที่ชำรุดหรือพันกันยุ่งเพิ่มความเสี่ยงจากการถูกไฟฟ้าดูด
- ▶ **เมื่อใช้เครื่องมือไฟฟ้าทำงานกลางแจ้ง ให้ใช้สายไฟต่อที่เหมาะสมสำหรับการใช้งานกลางแจ้ง** การใช้สายไฟต่อที่เหมาะสมสำหรับงานกลางแจ้งช่วยลดอันตรายจากการถูกไฟฟ้าดูด
- ▶ **หากไม่สามารถหลีกเลี่ยงการใช้เครื่องมือไฟฟ้าทำงานในสถานที่เปียกชื้นได้ ให้ใช้สวิตช์ตัดวงจรเมื่อเกิดการรั่วไหลของไฟฟ้าจากสายดิน (RCD)** การใช้สวิตช์ตัดวงจรเมื่อเกิดการรั่วไหลของไฟฟ้าจากสายดินช่วยลดความเสี่ยงต่อการถูกไฟฟ้าดูด

ความปลอดภัยของบุคคล

- ▶ **ท่านต้องอยู่ในสภาพเตรียมพร้อม ระมัดระวังในสิ่งที่ท่านกำลังทำอยู่ และมีสติขณะใช้เครื่องมือไฟฟ้าทำงาน** อย่าใช้เครื่องมือไฟฟ้าขณะที่ท่านกำลังเหนื่อยหรืออยู่ภายใต้การครอบงำของฤทธิ์ของยาเสพติด แอลกอฮอล์ และยา เมื่อใช้เครื่องมือไฟฟ้าทำงานในชั่วโมงที่ท่านขาดความเอาใจใส่อาจทำให้บุคคลมาดเจ็บอย่างรุนแรงได้
- ▶ **ใช้อุปกรณ์ปกป้องร่างกาย สวมแว่นตาป้องกันเสมอ** อุปกรณ์ปกป้อง เช่น หนวดกากันฝุ่น รองเท้ากันลื่น หมวกแข็ง หรือประคบหูกันเสียงดัง ที่เลือกใช้ตามความเหมาะสมกับสภาพการทำงาน สามารถลดอันตรายต่อบุคคลได้
- ▶ **ป้องกันการติดเครื่องโดยไม่ตั้งใจ ตรวจสอบให้แน่ใจว่าสวิตช์ขอยุ่ในตำแหน่งปิดก่อนเชื่อมต่อเข้ากับแหล่งจ่ายไฟ และ/หรือเบตเตอรี่แคช** ยกหรือถือเครื่องมือถือเครื่องโดยใช้นิ้วหัวที่สวิตช์ หรือเสียบปลั๊กไฟฟ้าขณะสวิตช์เปิดอยู่ อาจนำไปสู่อุบัติเหตุที่ร้ายแรงได้
- ▶ **นำเครื่องมือปรับแต่งหรือประแจปากดาบออกก่อนเปิดสวิตช์เครื่องมือไฟฟ้า** เครื่องมือหรือประแจปากดาบที่วางอยู่กับส่วนหนึ่งของเครื่องที่กำลังหมุนจะทำให้บุคคลมาดเจ็บได้
- ▶ **อย่าเอื้อมไกลเกินไป** ตั้งทำยีนที่มั่นคงและวางน้ำหนักให้สมดุลตลอดเวลา
ในลักษณะนี้ท่านสามารถควบคุมเครื่องมือไฟฟ้าในสถานการณ์ที่ไม่คาดคิดได้ดีกว่า
- ▶ **แต่งกายอย่างเหมาะสม** อย่าใส่เสื้อผ้าหลวมหรือสวมเครื่องประดับ เอาหมวก เสื้อผ้า และถุงมือ ออกห่างจากชิ้นส่วนที่กำลังหมุน เสื้อผ้าหลวม เครื่องประดับ และผมยาวอาจเข้าไปติดในส่วนของเครื่องที่กำลังหมุนได้

- ▶ หากเครื่องมือไฟฟ้ามีข้อเชื่อมต่อกับเครื่องดูดฝุ่นหรือเครื่องเก็บผง ให้ตรวจสอบให้แน่ใจว่าได้เชื่อมต่อและใช้งานอย่างถูกต้อง การใช้อุปกรณ์ดูดฝุ่นช่วยลดอันตรายที่เกิดจากฝุ่นได้

การใช้และการดูแลรักษาเครื่องมือไฟฟ้า

- ▶ อย่างผืนกำลังเครื่องมือไฟฟ้า ใช้เครื่องมือไฟฟ้าที่ถูกต้องตรงตามลักษณะงานของท่าน เครื่องมือไฟฟ้าที่ถูกต้องจะทำงานได้ดีกว่าและปลอดภัยกว่าในระดับสมรรถภาพที่ออกแบบไว้
- ▶ อย่าใช้เครื่องมือไฟฟ้าถ้าสวิทช์ไม่สามารถเปิดปิดได้ เครื่องมือไฟฟ้าที่ไม่สามารถควบคุมการเปิดปิดด้วยสวิทช์ได้ เป็นเครื่องมือไฟฟ้าที่ไม่ปลอดภัยและต้องส่งซ่อมแซม
- ▶ ก่อนปรับแต่งเครื่อง เปลี่ยนอุปกรณ์ประกอบ หรือเก็บเครื่องมือไฟฟ้าเข้าที่ ต้องถอดปลั๊กไฟออกจากแหล่งจ่ายไฟ และ/หรือถอดแบตเตอรี่ที่คอกออกจากเครื่องมือไฟฟ้า มาตรการป้องกันเพื่อความปลอดภัยนี้ช่วยลดความเสี่ยงจากการติดเครื่องโดยไม่ตั้งใจ
- ▶ เมื่อเลิกใช้งานเครื่องมือไฟฟ้า ให้เก็บเครื่องไว้ในที่เด็กหยิบไม่ถึง และไมอนุญาตให้บุคคลที่ไม่คุ้นเคยกับเครื่องหรือบุคคลที่ไม่ได้อ่านคำแนะนำเหล่านี้ใช้เครื่องมือไฟฟ้าเป็นของอันตรายหากตกอยู่ในมือของผู้ใช้ที่ไม่ได้รับการฝึกฝน
- ▶ บำรุงรักษาเครื่องมือไฟฟ้า ตรวจสอบชิ้นส่วนที่เคลื่อนที่ว่าวางไม่ตรงแนวหรือติดขัดหรือไม่ ตรวจสอบการแตกหักของชิ้นส่วนและสภาพอื่นใดที่อาจมีผลต่อการทำงานของเครื่องมือไฟฟ้า หากชำรุดต้องส่งเครื่องมือไฟฟ้าไปซ่อมแซมก่อนใช้งาน อุบัติเหตุหลายอย่างเกิดขึ้นเนื่องจากดูแลรักษาเครื่องไม่ดีพอ
- ▶ รักษาเครื่องมือตัดให้คมและสะอาด หากบำรุงรักษาเครื่องมือที่มีขอบตัดแหลมคมอย่างถูกต้อง จะสามารถตัดได้ลื่นไม่ติดขัดและควบคุมได้ง่ายกว่า
- ▶ ใช้เครื่องมือไฟฟ้า อุปกรณ์ประกอบ เครื่องมือ และอุปกรณ์อื่น ๆ ตรงตามคำแนะนำเหล่านี้ โดยคำนึงถึงเงื่อนไขการทำงานและงานที่จะทำ การใช้เครื่องมือไฟฟ้าทำงานที่ต่างไปจากวัตถุประสงค์การใช้งานของเครื่อง อาจนำไปสู่สถานการณ์ที่เป็นอันตรายได้

การบริการ

- ▶ ส่งเครื่องมือไฟฟ้าของท่านเข้ารับบริการจากช่างซ่อมที่มีคุณสมบัติเหมาะสม โดยใช้อะไหล่ที่เหมือนกับเท่านั้น ในลักษณะนี้ท่านจะแน่ใจได้ว่าเครื่องมือไฟฟ้าอยู่ในสภาพที่ปลอดภัย

คำเตือนเพื่อความปลอดภัยสำหรับส่วนกระแทก

คำเตือนเพื่อความปลอดภัยสำหรับการทำงานทั้งหมด

- ▶ **สวมประภหุ่ป้องกันเสียงดัง** การรับฟังเสียงดังอาจทำให้สูญเสียการได้ยิน
- ▶ **ใช้ตามจับเพิ่ม** การสูญเสียการควบคุมอาจทำให้บุคคลได้รับบาดเจ็บ
- ▶ **ยึดเครื่องมืออย่างถูกต้องก่อนใช้งาน** เครื่องมือนี้ที่แรงบิดสูง และหากไม่ยึดเครื่องมืออย่างถูกต้องระหว่างการทำงาน อาจสูญเสียการควบคุมซึ่งจะส่งผลกระทบต่อขนาดเจ็บ
- ▶ **เมื่อทำงานในบริเวณที่อุปกรณ์ตัดหรือสกรูอาจสัมผัสสายไฟฟ้าที่ซ่อนอยู่หรือสายไฟฟ้าของตัวเครื่องเอง ต้องจับเครื่องมือไฟฟ้าตรงพื้นผิวจับที่หุ้มฉนวน** หากอุปกรณ์ตัดหรือสกรูสัมผัสสายที่ "มีกระแสไฟฟ้า" ไหลผ่าน จะทำให้ชิ้นส่วนโลหะที่ไม่มีกำบังของเครื่องมือไฟฟ้าเกิด "มีกระแสไฟฟ้า" ด้วย และส่งผลให้ผู้ใช้งานเครื่องมือไฟฟ้าดูดได้

คำเตือนเพื่อความปลอดภัยเมื่อใช้ดอกสว่านยาว

- ▶ **อย่าทำงานด้วยความเร็วที่สูงกว่าอัตราความเร็วสูงสุดของดอกสว่าน** ที่ความเร็วที่สูงกว่า ดอกสว่านอาจโค้งงอเมื่อปล่อยให้หมุนอย่างอิสระโดยไม่สัมผัสชิ้นงาน และส่งผลให้ได้รับบาดเจ็บทางร่างกาย
- ▶ **เริ่มต้นเจาะด้วยความเร็วต่ำและให้ปลายดอกสว่านสัมผัสชิ้นงานเสมอ** ที่ความเร็วที่สูงกว่า ดอกสว่านอาจโค้งงอเมื่อปล่อยให้หมุนอย่างอิสระโดยไม่สัมผัสชิ้นงาน และส่งผลให้ได้รับบาดเจ็บทางร่างกาย
- ▶ **ใช้แรงกดให้ตรงกับแนวดอกสว่านเท่านั้นและอย่าใช้แรงกดมากเกินไป** ดอกสว่านอาจโค้งงอทำให้แตกหักหรือสูญเสียการควบคุม และส่งผลให้ได้รับบาดเจ็บทางร่างกาย

คำแนะนำเพื่อความปลอดภัยเพิ่มเติม

- ▶ **ใช้ตามจับเพิ่มหากจัดส่งมาพร้อมกับเครื่องการสูญเสียการควบคุมอาจทำให้บุคคลได้รับบาดเจ็บ**
- ▶ **จับเครื่องมือไฟฟ้าให้แน่นด้วยมือทั้งสองข้างและตั้งท่ายืนให้มั่นคงขณะทำงาน** ท่านจะสามารถนำทางเครื่องมือไฟฟ้าได้ปลอดภัยกว่าเมื่อจับเครื่องมือด้วยมือทั้งสองข้าง
- ▶ **ปิดสวิทช์เครื่องมือไฟฟ้าทันทีหากเครื่องมือติดขัด** ให้เตรียมพร้อมสำหรับปฏิกิริยาแรงบิดสูงซึ่งเป็นเหตุให้เกิดการตีกลับ เครื่องมือจะติดขัดเมื่อเครื่องมือไฟฟ้าถูกใช้งานเกินกำลังหรือเครื่องมือถูกบีบอัดอยู่ในชิ้นงาน
- ▶ **ยึดชิ้นงานให้แน่น** การยึดชิ้นงานด้วยเครื่องมือหนีบหรือแท่นจับจะมั่นคงกว่าการยึดด้วยมือ
- ▶ **ใช้เครื่องตรวจจับที่เหมาะสมเพื่อตรวจสอบหาสายไฟฟ้าหรือท่อสาธารณูปโภคที่อาจซ่อนอยู่ในบริเวณทำงาน**

หรือติดต่อบริษัทสารานุกรมโลกในพื้นที่เพื่อขอความช่วยเหลือ การสัมผัสกับสายไฟฟ้าอาจทำให้เกิดไฟไหม้หรือถูกไฟฟ้าดูด การทำให้ท่อแก๊ซเสียหายอาจทำให้เกิดระเบิด การเจาะเข้าไปในท่อน้ำทำให้ทรัพย์สินเสียหาย หรืออาจเป็นเหตุให้ถูกไฟฟ้าดูดได้

- **ขอให้เครื่องมือไฟฟ้าหยุดสนิทก่อนวางเครื่องลงบนพื้น**
เครื่องมือที่ปล่อยอาจติดขัดและทำให้สูญเสียการควบคุมเครื่องมือไฟฟ้า

รายละเอียดผลิตภัณฑ์และข้อมูล

จำเพาะ



อ่านคำเตือนเพื่อความปลอดภัยและคำแนะนำทั้งหมด การไม่ปฏิบัติตามคำเตือนและคำสั่งอาจเป็นสาเหตุให้ถูกไฟฟ้าดูด เกิดไฟไหม้และ/หรือได้รับบาดเจ็บอย่างร้ายแรง

กรุณาดูภาพประกอบในส่วนหน้าของคู่มือการใช้งาน

ประโยชน์การใช้งานของเครื่อง

เครื่องนี้ใช้สำหรับเจาะตอกในคอนกรีต อิฐ และหิน และยังใช้สำหรับงานสกัดเบาๆ เครื่องนี้ยังเหมาะสำหรับเจาะโดยไม่กระทบแก๊ซในไม้ โลหะ เซรามิก และพลาสติกอีกด้วย เครื่องมือไฟฟ้าที่มีระบบควบคุมอิเล็กทรอนิกส์และการหมุนซ้าย/ขวาสามารถใช้งานสกู๊ดได้ด้วย

ส่วนประกอบที่แสดงภาพ

ลำดับเลขของส่วนประกอบผลิตภัณฑ์อ้างอิงถึงส่วนประกอบของเครื่องที่แสดงในหน้าภาพประกอบ

- (1) หัวจับตอกชนิดเปลี่ยนเร็ว (GBH 2-28 DFV)
- (2) หัวจับตอก SDS-plus (GBH 2-28 DFV)
- (3) ตามจับเครื่องมือ SDS-plus

ข้อมูลทางเทคนิค

ส่วนโรตารี		GBH 2-28 D		GBH 2-28 DV	
หมายเลขสินค้า		3 611 B67 0C. 3 611 B67 0L.	3 611 B67 0K. 3 611 B67 08.	3 611 B67 1F.	3 611 B67 10.
หัวจับตอก		-	-	-	-
กำลังไฟฟ้าที่กัดตัดันเข้า	วัตต์	850	820	850	820
อัตรากระแทก	min ⁻¹	0-5100	0-5100	0-5100	0-5100
พลังงานกระแทกต่อครั้งตามระเบียบการ	จูล	3.2	3.2	3.2	3.2

- (4) ผาครอบกันฝุ่น
- (5) ปลอกสำหรับล๊อค
- (6) แหวนล๊อคสำหรับหัวจับตอก (GBH 2-28 DFV)
- (7) สวิตช์เปลี่ยนทิศทางการหมุน
- (8) ปุ่มล๊อคสวิตช์เปิด-ปิด
- (9) สวิตช์เปิด-ปิด
- (10) ปุ่มปลดล๊อคสวิตช์หยุดกระแทก/หยุดหมุน
- (11) สวิตช์หยุดกระแทก/หยุดหมุน
- (12) ปุ่มสำหรับปรับก้านวัดความลึก
- (13) ตามจับเพิ่ม (พื้นผิวจับหุ้มฉนวน)
- (14) ก้านวัดความลึก
- (15) ตามจับ (พื้นผิวจับหุ้มฉนวน)
- (16) ร่องเอกลักษณ์
- (17) หัวจับตอก (GBH 2-28 DFV)
- (18) ปลอกหน้าของหัวจับตอกชนิดเปลี่ยนเร็ว (GBH 2-28 DFV)
- (19) แหวนกั้นของหัวจับชนิดเปลี่ยนเร็ว (GBH 2-28 DFV)
- (20) ช่องดูดออกของ Saugfix^{A)}
- (21) น็อตหนีบสำหรับ Saugfix^{A)}
- (22) ก้านวัดความลึกของ Saugfix^{A)}
- (23) ท่อซึ้นลมร่วมกันของ Saugfix^{A)}
- (24) น็อตปีกของ Saugfix^{A)}
- (25) น็อตปีกของ Saugfix^{A)}
- (26) ตามจับตอกทั่วไปที่มีก้าน SDS-plus^{A)}

A) อุปกรณ์ประกอบที่แสดงภาพหรืออธิบายไม่รวมอยู่ในการจัดส่งมาตรฐาน
กรุณาดูอุปกรณ์ประกอบทั้งหมดในรายการแสดงอุปกรณ์ประกอบของเรา

ส่วนโรตารี		GBH 2-28 D			GBH 2-28 DV
EPTA-Procedure 05:2016					
อัตราความเร็วพิกัด	นาที ⁻¹	0-1300	0-1300	0-1300	0-1300
ด้ามจับเครื่องมือ		SDS-plus	SDS-plus	SDS-plus	SDS-plus
เส้นผ่าศูนย์กลางปลอก แกน	มม.	50	50	50	50
เส้นผ่าศูนย์กลางการเจาะ สูงสุด					
- คอนกรีต	มม.	28	28	28	28
- งานก่ออิฐ (ด้วย ดอกเจาะคว้าน)	มม.	68	68	68	68
- เหล็กกล้า	มม.	13	13	13	13
- ไม้	มม.	30	30	30	30
น้ำหนักตามระเบียบ การ EPTA- Procedure 01:2014	กก.	2.9	2.9	2.9	2.9
ระดับความปลอดภัย		☐/	☐/	☐/	☐/

ส่วนโรตารี		GBH 2-28 DFV	
หมายเลขสินค้า		3 611 B67 2C. 3 611 B67 2L.	3 611 B67 2K. 3 611 B67 28.
หัวจับดอก		●	●
กำลังไฟฟ้าพิกัดด้านเข้า	วัตต์	850	820
อัตรากระแทก	min ⁻¹	0-5100	0-5100
พลังงานกระแทกต่อครั้งตาม ระเบียบการ EPTA- Procedure 05:2016	จูล	3.2	3.2
อัตราความเร็วพิกัด	นาที ⁻¹	0-1300	0-1300
ด้ามจับเครื่องมือ		SDS-plus	SDS-plus
เส้นผ่าศูนย์กลางปลอกแกน	มม.	50	50
เส้นผ่าศูนย์กลางการเจาะ สูงสุด			
- คอนกรีต	มม.	28	28
- งานก่ออิฐ (ด้วยดอกเจาะ คว้าน)	มม.	68	68
- เหล็กกล้า	มม.	13	13
- ไม้	มม.	30	30

ส่วนโรตารี

GBH 2-28 DFV

น้ำหนักตามระเบียบการ EPTA-Procedure 01:2014	กก.	3,1	3,1
ระดับความปลอดภัย		□/	□/

ค่าที่แก้ไขได้กับแรงดันไฟฟ้าอโนมอล [U] 230 โวลท์ ค่าเหล่านี้อาจเปลี่ยนแปลงไปสำหรับแรงดันไฟฟ้าที่แตกต่างกัน และโมเดลที่ผลิตสำหรับเฉพาะประเทศ

การติดตั้ง

▶ ดึงปลั๊กไฟออกจากเต้าเสียบก่อนปรับแต่งเครื่อง

ด้ามจับเพิ่ม

▶ ใช้เครื่องมือไฟฟ้าร่วมกับด้ามจับเพิ่ม (13) เสมอ

การหมุนด้ามจับเพิ่ม (ดูภาพประกอบ A)

ท่านสามารถจับด้ามจับเพิ่ม (13) หนีไปยังตำแหน่งใดก็ได้ เพื่อให้ได้ท่าทำงานที่มั่นคงและเหนียวแน่น

- หมุนก้านจับด้านล่างของด้ามจับเพิ่ม (13) ทวนเข็มนาฬิกา และหันด้ามจับเพิ่ม (13) ไปยังตำแหน่งที่ต้องการ จากนั้นจึงหมุนก้านจับด้านล่างของด้ามจับเพิ่ม (13) ในทิศตามเข็มนาฬิกากลับเข้าที่ให้แน่น ตรวจสอบให้แน่ใจว่าสายรัดปรับความตึงของด้ามจับเพิ่ม อยู่ในร่องที่ตัวเครื่อง

การปรับความลึกการเจาะ (ดูภาพประกอบ B)

ท่านสามารถใช้ก้านวัดความลึก (14) เพื่อตั้งความลึกการเจาะ X ที่ต้องการ

- กดปุ่มสำหรับปรับก้านวัดความลึก (12) และใส่ก้านวัดความลึกเข้าไปในด้ามจับเพิ่ม (13) ต้องหันพื้นผิวที่เป็นร่องบนก้านวัดความลึก (14) ลงด้านล่าง
- ดันเครื่องมือ SDS-plus เข้าในด้ามจับเครื่องมือ SDS-plus (3) จนสุด หากเครื่องมือ SDS-plus เคลื่อนไหว อาจทำให้ปรับความลึกการเจาะได้ไม่ถูกต้อง
- ดึงก้านวัดความลึกออกมาจนระยะห่างระหว่างปลายดอกร ส่วนและปลายก้านวัดความลึกเท่ากับความลึกการเจาะที่ต้องการ X

การเลือกหัวจับดอกและเครื่องมือ

สำหรับการเจาะดอกและการสกัดต้องใช้เครื่องมือ SDS-plus ที่ใส่ในหัวจับดอก SDS-plus

สำหรับการเจาะโดยไม่กระแทกในไม้ โลหะ เซรามิก และพลาสติก รวมทั้งการขันสกรู ต้องใช้เครื่องมือที่ไม่มี SDS-

plus (ด. ย. เช่น ดอกส่วนที่มีก้านทรงกระบอก) ต้องใช้หัวจับดอกไร้เฟืองในสำหรับเครื่องมือเจาะประเภทนี้

การถอด/การใส่หัวจับดอกชนิดเปลี่ยนเร็ว

(GBH 2-28 DFV)

การถอดหัวจับดอกแบบเปลี่ยนเร็ว (ดูภาพประกอบ C)

- ดึงแหวนล็อกสำหรับหัวจับดอกแบบเปลี่ยนเร็ว (6) ไปด้านหลัง จับแหวนล็อกให้อยู่ในตำแหน่งนี้ และดึงหัวจับดอกแบบเปลี่ยนเร็ว SDS-plus (2) หรือหัวจับดอกแบบเปลี่ยนเร็วหนีบเร็ว (1) ออกจากด้านหน้า
- เมื่อถอดดอกแล้ว ต้องป้องกันหัวจับดอกไม่ให้เอนสกปรก

การใส่หัวจับดอกแบบเปลี่ยนเร็ว (ดูภาพประกอบ D)

- ▶ ใช้เฉพาะอุปกรณ์ที่เป็นของแท้เท่านั้น และตรวจสอบจำนวนร่องเอกลักษณ์ (16) อนุญาตให้เปลี่ยนเฉพาะหัวจับดอกที่มีสองหรือสามร่องเอกลักษณ์เท่านั้น หากไม่สามารถเปลี่ยนหัวจับดอกที่เหมาะสมได้สำหรับเครื่องมือไฟฟ้านี้ เครื่องมือที่ใช้อาจล้มเหลวในระหว่างการดำเนินการ
- ทำความสะอาดหัวจับดอกก่อนใส่ และเคลือบจาระบีบางๆ ที่ปลายก้าน
- จับหัวจับดอก SDS-plus (2) หรือหัวจับดอกชนิดเปลี่ยนเร็ว (1) เต็มๆ มือ ดันหัวจับดอกหมุนใส่บนข้อรับหัวจับดอก (17) จนได้ยินเสียงขบเข้าล็อกอย่างชัดเจน
- หัวจับดอกจะล็อกโดยอัตโนมัติ ดึงหัวจับดอกเพื่อตรวจสอบการล็อก

การเปลี่ยนเครื่องมือ

ฝาครอบกันฝุ่น (4) ส่วนใหญ่จะป้องกันไม่ให้อันที่เกิดจากการเจาะลอดเข้าไปในด้ามจับเครื่องมือในระหว่างการใช้งาน เมื่อใส่เครื่องมือต้องระวังอย่าให้ฝาครอบกันฝุ่น (4) เสียหาย

- ▶ ต้องเปลี่ยนฝาครอบกันฝุ่นที่ชำรุดโดยทันที เราขอแนะนำ ควรส่งให้ศูนย์บริการหลังการขายเปลี่ยนให้

การเปลี่ยนเครื่องมือ (SDS-plus)

การใส่เครื่องมือ SDS-plus (ดูภาพประกอบ E)

หัวจับดอก SDS-plus ทำให้เปลี่ยนเครื่องมือเจาะได้ง่ายและสะดวกโดยไม่ต้องใช้เครื่องมืออื่นๆ ช่วย

ตามเงื่อนไขของระบบ เครื่องมือ SDS-plus สามารถเคลื่อนไหวได้อย่างอิสระ ดังนั้นเมื่อเดินตัวเปล่า เครื่องมือจะวิ่งส่ายจากแนวรัศมี ซึ่งจะไม่มีผลต่อความเที่ยงตรงของรูเจาะ ดอกสว่านจะตั้งตัวให้อยู่ตรงกลางเองระหว่างการเจาะ

- GBH 2-28 DFV: ใส่หัวจับดอก SDS-plus (2)
- ทำความสะอาดและทาสีจาระบีบางๆ ที่ปลายก้านเครื่องมือ
- จับเครื่องมือหมุนใส่ในด้ามจับเครื่องมือจนเข้าล็อกโดยอัตโนมัติ
- ดึงเครื่องมือเพื่อตรวจสอบการล็อก

การถอดเครื่องมือ SDS-plus (ดูภาพประกอบ F)

- ดันปลอกสำหรับล็อก (5) ไปด้วยหลังและถอดเครื่องมือออก

การเปลี่ยนเครื่องมือ (ไม่มี SDS-plus)

(GBH 2-28 DFV)

การใส่เครื่องมือ (ดูภาพประกอบ G)

หมายเหตุ: อย่าใช้เครื่องมือที่ไม่มี SDS-plus สำหรับเจาะดอกหรือสกัด! เครื่องมือที่ไม่มี SDS-plus และหัวจับดอกของเครื่องมืออาจชำรุดจากการเจาะดอกหรือสกัด

- ใส่หัวจับดอกชนิดเปลี่ยนเร็ว (1)
- จับแหวนยึด (19) ของหัวจับดอกแบบเปลี่ยนเร็วหนีบเร็วให้แน่น เปิดตามจับเครื่องมือโดยหมุนปลอกหน้า (18) จนสามารถใส่เครื่องมือเข้าไปได้ จับแหวนยึด (19) ให้แน่น และหมุนปลอกหน้า (18) ไปในทิศทางลูกศรจนได้ยินเสียงขบเข้าล็อกอย่างชัดเจน
- ดึงเครื่องมือเพื่อตรวจสอบการเข้าในตำแหน่งอย่างแน่นหนา

หมายเหตุ: หากตามจับเครื่องมือถูกเปิดออกจนสุด อาจได้ยินเสียงขบเข้าล็อกขณะหมุนด้ามจับเครื่องมือให้ปิด และตามจับเครื่องมือไม่มีติลง

ในกรณีนี้ให้หมุนปลอกหน้า (18) ไปในทิศทางข้ามกับทิศทางลูกศรหนึ่งครั้ง จากนั้นตามจับเครื่องมือจะสามารถเปิดได้

- หมุนสวิตช์หยุดกระแทก/หยุดหมุน (11) ไปที่ตำแหน่ง "การเจาะ"

การถอดเครื่องมือ (ดูภาพประกอบ H)

- จับแหวนยึด (19) ของหัวจับดอกแบบเปลี่ยนเร็วหนีบเร็วให้แน่น เปิดตามจับเครื่องมือโดยหมุนปลอกหน้า (18) ไปตามทิศทางลูกศรจนสามารถถอดเครื่องมือออกมาได้

การดูแลผู้ด้วย Saugfix (อุปกรณ์ประกอบ)

การดูดฝุ่น/ซีลื้อย

ฝุ่นที่ได้จากวัสดุ เช่น เคลือบผิวที่มีสารตะกั่ว ไม้ยางประเภทเรซาดู และโลหะ อาจเป็นอันตรายต่อสุขภาพ การสัมผัสหรือการหายใจเอาฝุ่นเข้าไปอาจทำให้เกิดปฏิกิริยาแพ้ฝุ่น และ/หรือนำมาซึ่งโรคติดเชื้อระบบหายใจแก่ผู้ใช้เครื่องมือหรือผู้ที่ยืนอยู่ใกล้เคียง

- ฝุ่นบางประเภท เช่น ฝุ่นไม้โอ๊ก หรือไม้บีช นับเป็นสารที่ทำให้เกิดมะเร็ง โดยเฉพาะอย่างยิ่งเมื่อผสมกับสารเติมแต่งเพื่อบำบัดไม้ (โครเมต ผลิตภัณฑ์รักษาเนื้อไม้) สำหรับวัสดุที่มีแอสเบสทอสถองให้ผู้ใช้เชี่ยวชาญทำงานเท่านั้น
- ใช้ระบบดูดฝุ่นออกที่เหมาะสมกับประเภทวัสดุ มากเท่าที่จะทำได้
- จัดสถานที่ทำงานให้มีการระบายอากาศที่ดี
- ขอแนะนำให้สวมหน้ากากป้องกันการติดเชื้อที่มีระดับ-ใส่กรอง P2

ปฏิบัติตามกฎข้อบังคับสำคัญอื่นๆ ที่เกี่ยวกับวัสดุชิ้นงานที่ยังคงใช้ในประเทศของท่าน

▶ ป้องกันการสะสมของฝุ่นในสถานที่ทำงาน

ฝุ่นสามารถถูกใหม่อย่างง่ายดาย

การติดตั้ง Saugfix (ดูภาพประกอบ I)

สำหรับการดูดฝุ่นออก ต้องใช้ Saugfix (อุปกรณ์ประกอบ) ขณะเจาะรู Saugfix จะร่นกลับเพื่อให้ส่วนหัวของ Saugfix อยู่ชิดกับพื้นผิวรูเจาะเสมอ

- กดปุ่มปรับก้านวัดความลึก (12) และถอดก้านวัดความลึก (14) ออกกดปุ่ม (12) อีกครั้งและใส่ Saugfix เข้าในด้ามจับเพิ่ม (13) จากด้านบน
 - ต่อท่อดูดฝุ่น (เส้นผ่าศูนย์กลาง 19 มม. อุปกรณ์ประกอบ) เข้ากับช่องดูดออก (20) ของ Saugfix
- เครื่องดูดฝุ่นต้องมีลักษณะการใช้งานที่เหมาะสมกับประเภทวัสดุชิ้นงาน

ในกรณีดูดฝุ่นแห้งที่เป็นอันตรายต่อสุขภาพอย่างยิ่งหรืออาจก่อให้เกิดมะเร็งได้ ให้ใช้เครื่องดูดฝุ่นพิเศษ

การปรับความลึกการเจาะบน Saugfix (ดูภาพประกอบ J)

ท่านสามารถปรับความลึกการเจาะที่ต้องการ X ได้แม้ Saugfix ติดตั้งอยู่

- ดันเครื่องมือ SDS-plus เข้าในด้ามจับเครื่องมือ SDS-plus (3) จนสุดการเคลื่อนที่ของเครื่องมือ SDS-plus อาจทำให้ปรับความลึกการเจาะได้ไม่ถูกต้อง
- คลายนอตปิก (24) บน Saugfix

- จับเครื่องมือไฟฟ้าเข้าหาจุดที่จะเจาะอย่างมั่นคงโดยไม่ต้องเปิดสวิตช์ เครื่องมือ SDS-plus ต้องวางบนพื้นผิวที่จะเจาะ
- เลื่อนท่อนำ (25) ของ Saugfix ในที่ยึดเพื่อให้หัวของ Saugfix วางอยู่บนพื้นผิวที่จะเจาะ อย่าเลื่อนท่อนำ (25) ครอบเหนือท่อข้อต่อสวมกัน (23) มากเกินจำเป็น ทั้งนี้เพื่อจะสามารถมองเห็นมาตราส่วน (23) บนท่อข้อต่อสวมกันได้มากที่สุด
- ชันน็อตปิก (24) กลับเข้าให้แน่น คลายน็อตหนีบ (21) บนก้านวัดความลึกของ Saugfix
- เลื่อนก้านวัดความลึก (22) บนท่อข้อต่อสวมกัน (23) ในลักษณะให้ระยะทาง X ดังแสดงในภาพประกอบเท่ากับ ความลึกการเจาะที่ต้องการ
- ชันน็อตหนีบ (21) ในตำแหน่งนี้เข้าให้แน่น

การปฏิบัติงาน

การเริ่มต้นปฏิบัติงาน

- ▶ ให้สังเกตแรงดันไฟฟ้า! แรงดันไฟฟ้าจากแหล่งจ่ายไฟฟ้าต้องมีค่าตรงกับค่าแรงดันไฟฟ้าที่ระบุไว้บนแผ่นป้ายยึดติดเครื่อง เครื่องมือไฟฟ้าที่มีเครื่องหมาย 230 โวลต์ สามารถใช้งานกับ 220 โวลต์ ได้ด้วย

การตั้งโหมดทำงาน

ท่านสามารถเลือกโหมดทำงานของเครื่องมือไฟฟ้าด้วยสวิตช์หยุดกระแทก/หยุดหมุน (11)

- เมื่อต้องการเปลี่ยนโหมดทำงาน ให้กดปุ่มปลดล็อก (10) และหมุนสวิตช์หยุดกระแทก/หยุดหมุน (11) ไปยังตำแหน่งที่ต้องการจนได้ยินเสียงเขาล็อค

หมายเหตุ: เปลี่ยนโหมดทำงานเฉพาะเมื่อเครื่องมือไฟฟ้าปิดสวิตช์อยู่เท่านั้น! มิฉะนั้นเครื่องมือไฟฟ้าอาจชำรุดได้



ตำแหน่งสำหรับการเจาะตอกในคอนกรีตหรือหิน



ตำแหน่งสำหรับการเจาะ โดยไม่กระแทกในไม้ โลหะ เซรามิก และพลาสติก รวมทั้งการขันการขันสกรู



ตำแหน่ง Vario-Lock สำหรับปรับตำแหน่งสกรู
สวิตช์หยุดกระแทก/หยุดหมุน (11) จะไม่ล็อคในตำแหน่งนี้



ตำแหน่งสำหรับการสกัด

การกลับทิศทางการหมุน

ท่านสามารถใช้สวิตช์เปลี่ยนทิศทางการหมุน (7) เพื่อเปลี่ยนทิศทางการหมุนของเครื่องมือไฟฟ้า อย่างไรก็ตาม หากสวิตช์เปิด-ปิด (9) ถูกกดอยู่ จะไม่สามารถเปลี่ยนทิศทางการหมุน

- ▶ หมุนสวิตช์เปลี่ยนทิศทางการหมุน (7) เมื่อเครื่องหยุดนิ่งอยู่กับที่เท่านั้น

ตั้งทิศทางการหมุนสำหรับการเจาะตอก การเจาะ และการสกัด ไว้ที่การหมุนทางขวาเสมอ

- การหมุนทางขวา: หมุนสวิตช์เปลี่ยนทิศทางการหมุน (7) ทั้งสองข้างจนสุดไปที่ตำแหน่ง ←
- การหมุนทางซ้าย: หมุนสวิตช์เปลี่ยนทิศทางการหมุน (7) ทั้งสองข้างจนสุดไปที่ตำแหน่ง →

การเปิด-ปิดเครื่อง

- เปิดสวิตช์เครื่องมือไฟฟ้าโดยกดสวิตช์เปิด-ปิด (9)
- ล็อคสวิตช์เปิด-ปิดโดยกดสวิตช์เปิด-ปิด (9) ค้างไว้และดันปุ่มล็อค (8) เพิ่ม
- ปิดสวิตช์เครื่องมือไฟฟ้าโดยปล่อยนิ้วจากสวิตช์เปิด-ปิด (9) หากสวิตช์เปิด-ปิด (9) ถูกล็อค ให้กดสวิตช์เปิด-ปิดก่อน แล้วจึงปล่อยนิ้ว

การตั้งอัตราความเร็ว/อัตรากระแทก

- สามารถปรับอัตราความเร็ว/อัตรากระแทกของเครื่องมือไฟฟ้าที่เปิดสวิตช์ทำงานได้อย่างต่อเนื่อง ทั้งนี้ขึ้นอยู่กับแรงที่กดลงบนสวิตช์เปิด-ปิด (9)

กดสวิตช์เปิด-ปิด (9) เมาจะได้อัตราความเร็ว/อัตรากระแทกต่ำ กดสวิตช์แรงยิ่งขึ้นจะได้อัตราความเร็ว/อัตรากระแทกเพิ่มขึ้น

ข้อแนะนำในการทำงาน

- ▶ จับเครื่องมือไฟฟ้าข้ามหน้าสกรู/นอตเมื่อเครื่องปิดอยู่กับที่ เครื่องมือที่หมุนอยู่อาจลื่นไถล

การเปลี่ยนตำแหน่งสกัด (Vario-Lock)

ท่านสามารถล็อคคอกสกัดได้ 40 ตำแหน่ง ในลักษณะนี้ท่านสามารถตั้งทำงานได้เหมาะสมที่สุดสำหรับแต่ละรูปแบบการทำงาน

- ใส่คอกสกัดเข้าในด้ามจับเครื่องมือ
- หมุนสวิตช์หยุดกระแทก/หยุดหมุน (11) ไปที่ตำแหน่ง "Vario-Lock"
- หมุนเครื่องมือไปยังตำแหน่งการสกัดที่ต้องการ

- หมุนสวิตช์หยุดกระแทก/หยุดหมุน (11) ไปที่ตำแหน่ง "การสกัด" ด้วยวิธีนี้ด้ามจับเครื่องมือจะถูกล็อคไว้
- ดึงที่ค้ำขาการหมุนสำหรับการสกัดไว้ที่การหมุนทางขวา

การสกัดด้วยฟังก์ชันล็อค

เมื่อต้องการสกัดเป็นเวลานานโดยไม่ต้องกดสวิตช์เปิด-ปิด (9) อย่างต่อเนื่องให้ล็อคสวิตช์เปิด-ปิดในโหมดทำงาน "การสกัด"

- เมื่อต้องการล็อคให้กดสวิตช์เปิด-ปิด (9) ไปจนสุดและในขณะที่เดียวกันให้กดปุ่มล็อค (8)
- เมื่อต้องการปิดสวิตช์ให้กดปุ่มล็อค (8) อีกครั้ง

หมายเหตุ: หากท่านกลับสวิตช์ไปที่โหมดทำงานอื่นในขณะที่สวิตช์เปิด-ปิดล็อคอยู่ เครื่องมือไฟฟ้าจะปิดสวิตช์

ตัวหน่วงการสั่นสะเทือน

 ตัวหน่วงการสั่นสะเทือนเม็ดเสิร์จช่วยลดการสั่นสะเทือนที่เกิดขึ้น

- ▶ หากองค์กรประกอบตัวหน่วงการสั่นสะเทือนชำรุด อยาใช้เครื่องมือไฟฟ้าทำงานต่อไป

การใส่ดอกไขควง (ดูภาพประกอบ K)

- ▶ จับเครื่องมือไฟฟ้าเข้าบนหัวสกรู/นอตเมื่อเครื่องปิดอยู่เท่านั้น เครื่องมือที่หมุนอยู่อาจลื่นไถล

เมื่อใช้ดอกไขควงทำงานต้องใช้ด้ามจับดอกทั่วไป (26) ที่มีก้านติดตั้ง SDS-plus (อุปกรณ์ประกอบ) รวมด้วย

- ทำความสะอาดปลายก้านติดตั้ง และเคลือบจาระบีบางส่วน
- จับด้ามจับดอกทั่วไปหมุนใส่ในด้ามจับเครื่องมือจนเข้าล็อคโดยอัตโนมัติ
- ดึงด้ามจับดอกทั่วไปเพื่อตรวจสอบการล็อค
- ใส่ดอกไขควงเข้าไปในด้ามจับดอกทั่วไป ใช้ดอกไขควงที่มีขนาดพอดีกับหัวสกรูเท่านั้น
- เมื่อต้องการถอดด้ามจับดอกทั่วไปออกให้ดึงปลอกสำหรับล็อค (5) ไปด้านหลัง และถอดด้ามจับดอกทั่วไป (26) ออกจากด้ามจับเครื่องมือ

การบำรุงรักษาและการบริการ

การบำรุงรักษาและการทำความสะอาด

- ▶ ดึงปลั๊กไฟออกจากเต้าเสียบก่อนปรับแต่งเครื่อง
- ▶ เพื่อให้ทำงานได้อย่างถูกต้องและปลอดภัย ต้องรักษาเครื่องและช่องระบายอากาศให้สะอาดอยู่เสมอ

หากจำเป็นต้องเปลี่ยนสายไฟฟ้า ต้องส่งเครื่องให้ **Bosch** หรือศูนย์บริการหลังการขายที่ได้รับมอบหมายสำหรับเครื่องมือไฟฟ้า **Bosch** เปลี่ยนให้ ทั้งนี้เพื่อหลีกเลี่ยงอันตราย

- ▶ **ต้องเปลี่ยนฝาครอบกันฝุ่นที่ชำรุดโดยทันที เราขอแนะนำว่าควรส่งให้ศูนย์บริการหลังการขายเปลี่ยนให้**

- ทำความสะอาดด้ามจับเครื่องมือ (3) ทุกครั้งหลังใช้งาน

การบริการหลังการขายและการให้คำปรึกษาการใช้งาน

ศูนย์บริการหลังการขายของเรายินดีตอบคำถามของท่านที่เกี่ยวกับการบำรุงรักษาและการซ่อมแซมผลิตภัณฑ์รวมทั้งเรื่องอะไหล่ ภาพเขียนแบบการประกอบและข้อมูลเกี่ยวกับอะไหล่ กรุณาดูใน: www.bosch-pt.com ที่งานที่ปรึกษาของ บ็อบซ์ อินดี ให้ข้อมูลเกี่ยวกับผลิตภัณฑ์ของเราและอุปกรณ์ประกอบต่างๆ

เมื่อต้องการสอบถามและสั่งซื้ออะไหล่ กรุณาแจ้งหมายเลขสินค้า 10 หลักบนแผ่นป้ายรุ่นของผลิตภัณฑ์ทุกครั้ง

ไทย

ไทย บริษัท โรเบิร์ต บ็อบซ์ จำกัด
 เอฟวายไอ เซ็นเตอร์ อาคาร 1 ชั้น 5
 เลขที่ 2525 ถนนพระราม 4

แขวงคลองเตย เขตคลองเตย กรุงเทพฯ 10110

โทร: +66 2012 8888

แฟกซ์: +66 2064 5800

www.bosch.co.th

ศูนย์บริการซ่อมและฝึกอบรม บ็อบซ์
 อาคาร ลาซาลทาวเวอร์ ชั้น G ห้องเลขที่ 2
 บ้านเลขที่ 10/11 หมู่ 16
 ถนนศรีนครินทร์ ตำบลบางแก้ว อำเภอบางพลี
 จังหวัดสมุทรปราการ 10540
 ประเทศไทย
 โทรศัพท์ 02 7587555
 โทรสาร 02 7587525

การกำจัดขยะ

เครื่องมือไฟฟ้า อุปกรณ์ประกอบ และหีบห่อ ต้องนำไปแยกประเภทวัสดุเพื่อการรีไซเคิลที่เป็นมิตรต่อสิ่งแวดล้อม



อย่าทิ้งเครื่องมือไฟฟ้าลงในขยะครัวเรือน!

Bahasa Indonesia

Petunjuk Keselamatan

Petunjuk Keselamatan Umum Perkakas Listrik

⚠ PERINGATAN Bacalah semua petunjuk keselamatan dan semua petunjuk penggunaan. Kesalahan dalam menjalankan petunjuk keselamatan dan petunjuk penggunaan dapat mengakibatkan sengatan listrik, kebakaran, dan/atau cedera serius.

Simpanlah semua petunjuk keselamatan dan petunjuk penggunaan untuk acuan di masa mendatang.

Istilah "perkakas listrik" dalam petunjuk keselamatan mengacu pada perkakas listrik yang dioperasikan dengan listrik (mengggunakan kabel) atau perkakas listrik yang dioperasikan dengan baterai (tanpa kabel).

Keamanan tempat kerja

- ▶ **Jaga kebersihan dan pencahayaan area kerja.** Area yang berantakan atau gelap dapat memicu kecelakaan.
- ▶ **Jangan mengoperasikan perkakas listrik di lingkungan yang dapat memicu ledakan, seperti adanya cairan, gas, atau debu yang mudah terbakar.** Perkakas listrik dapat memancarkan bunga api yang kemudian mengakibatkan debu atau uap terbakar.
- ▶ **Jauhkan dari jangkauan anak-anak dan pengamat saat mengoperasikan perkakas listrik.** Gangguan dapat menyebabkan hilangnya kendali.

Keamanan listrik

- ▶ **Steker perkakas listrik harus sesuai dengan stopkontak. Jangan pernah memodifikasi steker. Jangan menggunakan steker adaptor bersama dengan perkakas listrik yang terhubung dengan sistem grounding.** Steker yang tidak dimodifikasi dan stopkontak yang cocok akan mengurangi risiko sengatan listrik.
- ▶ **Hindari kontak badan dengan permukaan yang terhubung dengan sistem grounding, seperti pipa, radiator, kompor, dan lemari es.** Terdapat peningkatan risiko terjadinya sengatan listrik jika badan Anda terhubung dengan sistem grounding.
- ▶ **Perkakas listrik tidak boleh terpapar hujan atau basah.** Air yang masuk ke dalam perkakas listrik menambah risiko terjadinya sengatan listrik.
- ▶ **Jangan menyalahgunakan kabel. Jangan gunakan kabel untuk membawa, menarik, atau melepas steker perkakas listrik. Jauhkan kabel dari panas, minyak, tepi yang tajam, atau komponen yang bergerak.** Kabel listrik yang rusak atau tersangkut menambah risiko terjadinya sengatan listrik.
- ▶ **Saat mengoperasikan perkakas listrik di luar ruangan, gunakan kabel ekstensi yang sesuai untuk penggunaan di luar ruangan.** Penggunaan kabel yang

cocok untuk pemakaian di luar ruangan mengurangi risiko terjadinya sengatan listrik.

- ▶ **Jika perkakas listrik memang harus dioperasikan di tempat yang lembap, gunakan pemutus arus listrik residu (RCD).** Penggunaan RCD akan mengurangi risiko terjadinya sengatan listrik.

Keselamatan personel

- ▶ **Tetap waspada, perhatikan aktivitas yang sedang dikerjakan, dan gunakan akal sehat saat mengoperasikan perkakas listrik. Jangan gunakan perkakas listrik saat mengalami kelelahan atau di bawah pengaruh narkoba, alkohol, atau obat-obatan.** Jika perkakas listrik dioperasikan dengan daya konsentrasi yang rendah, hal tersebut dapat menyebabkan cedera serius.
- ▶ **Gunakan peralatan pelindung diri. Selalu kenakan pelindung mata.** Dengan memakai pakaian dan sarana pelindung, misalnya masker anti debu, sepatu tertutup yang tidak licin, helm pelindung, atau pemalut telinga sesuai dengan pekerjaan yang dilakukan, hal tersebut dapat mengurangi risiko cedera.
- ▶ **Hindari start yang tidak disengaja. Pastikan switch berada di posisi off sebelum perkakas listrik dihubungkan ke sumber daya listrik dan/atau baterai, diangkat, atau dibawa.** Membawa perkakas listrik dengan jari menempel pada tombol atau perkakas listrik dalam keadaan hidup dapat memicu kecelakaan.
- ▶ **Singkirkan kunci penyetel atau kunci pas sebelum menghidupkan perkakas listrik.** Perkakas atau kunci pas yang masih menempel pada komponen perkakas listrik yang berputar dapat menyebabkan cedera.
- ▶ **Jangan melampaui batas. Berdirilah secara mantap dan selalu jaga keseimbangan.** Hal ini akan memberikan kontrol yang lebih baik terhadap perkakas listrik pada situasi yang tak terduga.
- ▶ **Kenakan pakaian dengan wajar. Jangan mengenakan perhiasan atau pakaian yang longgar. Jauhkan rambut, pakaian, dan sarung tangan dari bagian-bagian perkakas yang bergerak.** Pakaian yang longgar, rambut panjang atau perhiasan dapat tersangkut dalam bagian perkakas yang bergerak.
- ▶ **Jika disediakan perangkat untuk sambungan pengisapan debu dan alat pengumpulan, pastikan perangkat tersebut terhubung dan digunakan dengan benar.** Penggunaan alat pengumpulan dapat mengurangi bahaya yang disebabkan oleh debu.

Penggunaan dan pemeliharaan perkakas listrik

- ▶ **Jangan memaksakan perkakas listrik. Gunakan perkakas listrik yang sesuai untuk pekerjaan yang dilakukan.** Perkakas listrik yang sesuai akan bekerja dengan lebih baik dan aman sesuai tujuan penggunaan.
- ▶ **Jangan gunakan perkakas listrik dengan switch yang tidak dapat dioperasikan.** Perkakas listrik yang switchnya tidak berfungsi dapat menimbulkan bahaya dan harus diperbaiki.

- ▶ **Tariklah steker dari stopkontak dan/atau keluarkan baterai sebelum melakukan penyetelan pada perkakas listrik, penggantian aksesoris atau sebelum menyimpan perkakas listrik.** Tindakan keselamatan kerja ini mengurangi risiko perkakas listrik beroperasi secara tiba-tiba.
- ▶ **Jauhkan dan simpan perkakas listrik dari jangkauan anak-anak dan jangan biarkan orang-orang yang tidak mengetahui cara menggunakan perkakas listrik, mengoperasikan perkakas listrik.** Perkakas listrik dapat membahayakan jika digunakan oleh orang-orang yang tidak terlatih.
- ▶ **Rawatlah perkakas listrik. Periksa komponen yang bergerak apabila tidak lurus atau terikat, kerusakan komponen, dan kondisi lain yang dapat mengganggu pengoperasian perkakas listrik. Apabila rusak, perbaiki perkakas listrik sebelum digunakan.** Banyak kecelakaan terjadi karena perkakas listrik tidak dirawat dengan seksama.
- ▶ **Jaga ketajaman dan kebersihan alat.** Alat pemotong dengan pisau pemotong yang tajam dan dirawat dengan baik tidak akan mudah tersangkut dan lebih mudah dikendalikan.
- ▶ **Gunakan perkakas listrik, aksesoris, dan komponen perkakas dll sesuai dengan petunjuk ini, dengan mempertimbangkan kondisi kerja dan pekerjaan yang akan dilakukan.** Penggunaan perkakas listrik untuk tujuan berbeda dari fungsinya dapat menyebabkan situasi yang berbahaya.

Servis

- ▶ **Minta teknisi berkualifikasi untuk menyervis perkakas listrik dengan hanya menggunakan suku cadang yang identik.** Dengan demikian, hal ini akan memastikan keamanan perkakas listrik.

Peringatan Keselamatan Hammer

Petunjuk keselamatan untuk semua pengoperasian

- ▶ **Kenakan sumbat telinga.** Suara bising alat dapat menyebabkan berkurangnya pendengaran.
- ▶ **Gunakan gagang tambahan.** Kehilangan kendali dapat menyebabkan cedera pribadi.
- ▶ **Kencangkan alat dengan benar sebelum digunakan.** Alat ini menghasilkan torsi output yang tinggi dan dapat terjadi kehilangan kendali yang mengakibatkan cedera jika alat tidak dikencangkan dengan benar selama pengoperasian.
- ▶ **Pegang perkakas listrik pada permukaan gagang berisolator saat mengoperasikannya, aksesoris pemotong atau pengunci dapat bersentuhan dengan kabel yang tidak terlihat atau kabelnya sendiri.** Aksesoris pemotong atau pengunci yang bersentuhan dengan kabel yang dialiri listrik dapat menyebabkan bagian logam perkakas listrik yang terbuka dialiri listrik sehingga pengguna dapat tersengat listrik.

Petunjuk keselamatan saat menggunakan mata bor panjang

- ▶ **Jangan pernah mengoperasikan alat dengan kecepatan yang lebih tinggi dari nilai kecepatan maksimal mata bor.** Pada kecepatan yang tinggi, mata bor akan membengkok jika berputar secara bebas tanpa menyentuh benda kerja dan dapat menyebabkan cedera terhadap pengguna.
- ▶ **Selalu hidupkan alat bor pada kecepatan rendah dengan ujung mata bor menyentuh benda kerja.** Pada kecepatan yang tinggi, mata bor akan membengkok jika berputar secara bebas tanpa menyentuh benda kerja dan dapat menyebabkan cedera terhadap pengguna.
- ▶ **Tekan hanya pada garis langsung dengan mata bor dan jangan tekan secara berlebihan.** Mata bor dapat membengkok dan menyebabkan kerusakan atau hilang kendali sehingga menyebabkan cedera terhadap pengguna.

Petunjuk Keselamatan tambahan

- ▶ **Gunakan handle tambahan, jika tersedia.** Kehilangan kendali dapat menyebabkan cedera.
- ▶ **Pegang erat perkakas listrik dengan kedua tangan selama mengoperasikannya dan pastikan Anda berdiri di posisi aman.** Gunakan perkakas listrik dengan kedua tangan secara hati-hati.
- ▶ **Segera matikan perkakas listrik jika alat tambahan terkunci. Bersiaplah dengan reaksi tinggi yang menyebabkan sentakan.** Alat tambahan akan terkunci jika perkakas listrik mengalami kelebihan beban atau perkakas bergerak miring pada benda kerja.
- ▶ **Gunakan alat kerja dengan aman.** Benda yang ditahan dalam alat pemegang atau baus lebih aman daripada benda yang dipegang dengan tangan.
- ▶ **Gunakanlah alat detektor logam yang cocok untuk mencari kabel dan pipa yang tidak terlihat atau hubungi perusahaan pengadaan setempat.** Sentuhan dengan kabel-kabel listrik dapat mengakibatkan api dan kontak listrik. Pipa gas yang dirusak dapat mengakibatkan ledakan. Pipa air yang dirusak mengakibatkan kerusakan barang-barang atau dapat mengakibatkan kontak listrik.
- ▶ **Sebelum meletakkan perkakas listrik, tunggulah hingga perkakas berhenti berputar.** Alat kerja dapat tersangkut dan menyebabkan perkakas listrik tidak dapat dikendalikan.

Spesifikasi produk dan performa



Bacalah semua petunjuk keselamatan dan petunjuk penggunaan. Kesalahan dalam menjalankan petunjuk keselamatan dan petunjuk penggunaan dapat mengakibatkan kontak listrik, kebakaran, dan/atau luka-luka

yang berat.

Perhatikan ilustrasi yang terdapat pada sisi sampul panduan pengoperasian.

Tujuan penggunaan

Perkakas listrik ini cocok untuk pengeboran benda keras pada beton, batu bata dan batu-batuan serta untuk pekerjaan memahat yang ringan. Perkakas listrik juga cocok untuk mengebor tanpa getaran pada kayu, logam, keramik dan bahan sintetis. Perkakas listrik dengan penyetelan elektronik dan arah putaran ke kanan/kiri juga cocok untuk menyekrup.

Ilustrasi komponen

Nomor-nomor dari bagian-bagian perkakas pada gambar sesuai dengan gambar perkakas listrik pada halaman bergambar.

- (1) Chuck bor penggantian cepat (GBH 2-28 DFV)
- (2) Chuck bor penggantian SDS plus (GBH 2-28 DFV)
- (3) Dudukan alat kerja SDS plus
- (4) Kap pelindung debu
- (5) Selongsong pengunci
- (6) Ring pengunci chuck bor penggantian (GBH 2-28 DFV)
- (7) Switch arah putaran
- (8) Tombol pengunci untuk tombol on/off
- (9) Tombol on / off
- (10) Tombol pelepas kunci switch getaran/penghenti putaran
- (11) Switch getaran/penghenti putaran
- (12) Tombol untuk pengaturan pembatas kedalaman
- (13) Gagang tambahan (permukaan genggam berisolator)
- (14) Pembatas kedalaman
- (15) Gagang (permukaan genggam berisolator)
- (16) Alur-alur pengenalan
- (17) Dudukan chuck bor (GBH 2-28 DFV)
- (18) Selongsong depan chuck bor penggantian cepat (GBH 2-28 DFV)
- (19) Ring penahan chuck bor penggantian cepat (GBH 2-28 DFV)
- (20) Lubang pengisian Saugfix^{A)}
- (21) Baut penjepit Saugfix^{A)}
- (22) Pembatas kedalaman Saugfix^{A)}
- (23) Pipa teleskopik Saugfix^{A)}
- (24) Baut kupu-kupu Saugfix^{A)}
- (25) Pipa pemandu Saugfix^{A)}
- (26) Holder universal dengan batang pemasang SDS plus^{A)}

A) Aksesori yang ada pada gambar atau yang dijelaskan tidak termasuk dalam lingkup pengiriman standar. Semua aksesori yang ada dapat Anda lihat dalam program aksesori kami.

Data teknis

Bor hammer		GBH 2-28 D		GBH 2-28 DV	
Nomor seri		3 611 B67 0C. 3 611 B67 0L.	3 611 B67 0K. 3 611 B67 08.	3 611 B67 1F.	3 611 B67 10.
Chuck bor penggantian		-	-	-	-
Input daya nominal	W	850	820	850	820
Tingkat getaran	min ⁻¹	0-5100	0-5100	0-5100	0-5100
Daya tiap getaran sesuai dengan EPTA-Procedure 05:2016	J	3,2	3,2	3,2	3,2
Kecepatan nominal	min ⁻¹	0-1300	0-1300	0-1300	0-1300
Dudukan alat kerja		SDS plus	SDS plus	SDS plus	SDS plus
Diameter leher spindel	mm	50	50	50	50
Diameter pengeboran maks.					
- Beton	mm	28	28	28	28
- Tembok (dengan mata bor pipa)	mm	68	68	68	68
- Baja	mm	13	13	13	13
- Kayu	mm	30	30	30	30
Berat sesuai dengan EPTA-Procedure 01:2014	kg	2,9	2,9	2,9	2,9
Tingkat perlindungan		□ / II	□ / II	□ / II	□ / II

Bor hammer		GBH 2-28 DFV	
Nomor seri		3 611 B67 2C. 3 611 B67 2L.	3 611 B67 2K. 3 611 B67 28.
Chuck bor penggantian		●	●
Input daya nominal	W	850	820
Tingkat getaran	min ⁻¹	0-5100	0-5100
Daya tiap getaran sesuai dengan EPTA-Procedure 05:2016	J	3,2	3,2
Kecepatan nominal	min ⁻¹	0-1300	0-1300
Dudukan alat kerja		SDS plus	SDS plus
Diameter leher spindel	mm	50	50
Diameter pengeboran maks.			
- Beton	mm	28	28
- Tembok (dengan mata bor pipa)	mm	68	68
- Baja	mm	13	13
- Kayu	mm	30	30
Berat sesuai dengan EPTA-Procedure 01:2014	kg	3,1	3,1
Tingkat perlindungan		□/II	□/II

Data-data berlaku untuk tegangan nominal [U] 230 V. Pada tegangan yang berbeda dan pada model khusus tiap negara data-data ini dapat bervariasi.

Pemasangan

- ▶ **Sebelum mulai dengan pekerjaan pada perkakas listrik, tariklah steker dari stopkontak.**

Gagang tambahan

- ▶ **Hanya gunakan perkakas listrik dengan gagang tambahan (13).**

Memutar gagang tambahan (lihat gambar A)

Gagang tambahan (13) dapat digerakkan ke arah mana pun untuk memungkinkan posisi kerja yang aman dan tidak melelahkan.

- Putar bagian bawah gagang tambahan (13) berlawanan arah jarum jam dan gerakan gagang tambahan (13) ke posisi yang diinginkan. Setelah itu, putar dan kencangkan kembali bagian bawah gagang tambahan (13) searah jarum jam.
Pastikan tali pengencang gagang tambahan berada dalam alur yang tersedia di housing.

Mengatur kedalaman pengeboran (lihat gambar B)

Dengan pembatas kedalaman (14), kedalaman lubang X yang diinginkan dapat ditetapkan.

- Tekan tombol untuk mengatur pembatas kedalaman (12) dan pasang pembatas kedalaman ke gagang tambahan (13).

Permukaan yang menonjol pada pembatas kedalaman (14) harus menghadap ke bawah.

- Dorong alat sisipan SDS plus ke dalam dudukan alat kerja SDS plus (3) hingga maksimal. Alat kerja SDS plus yang goyah dapat menyebabkan kesalahan dalam penyetelan kedalaman bor.
- Tarik pembatas kedalaman hingga jarak antara ujung mata bor dan ujung pembatas kedalaman sesuai dengan kedalaman pengeboran X yang diinginkan.

Memilih chuck bor dan alat kerja

Untuk mengebor benda keras dan memahat, diperlukan alat kerja SDS plus yang dipasang ke dalam chuck bor SDS plus. Alat kerja tanpa SDS plus (misalnya bor dengan batang berbentuk silinder) digunakan untuk pengeboran tanpa getaran pada kayu, logam, keramik dan bahan sintetis serta untuk penyekrupan. Untuk alat kerja tersebut diperlukan chuck bor pengencangan cepat.

Melepaskan/memasang chuck bor penggantian (GBH 2-28 DFV)

Melepaskan chuck bor penggantian (lihat gambar C)

- Tarik ring pengunci chuck bor penggantian (6) ke belakang, tahan ring pengunci pada posisi ini dan tarik chuck bor penggantian SDS plus (2) atau chuck bor penggantian pengencangan cepat (1) ke depan hingga terlepas.

- Jaga kebersihan chuck bor penggantian setelah dilepaskan.

Memasang chuck bor penggantian (lihat gambar D)

- ▶ **Hanya gunakan peralatan original khusus dan perhatikan jumlah alur-alur pengenal (16). Hanya chuck bor penggantian dengan dua atau tiga alur-alur pengenal yang diperbolehkan.** Jika chuck bor penggantian tidak cocok untuk perkakas listrik yang digunakan, alat sisipan dapat terlepas saat perkakas dioperasikan.
- Bersihkan chuck bor penggantian sebelum dipasang dan lumasi ujungnya dengan sedikit minyak.
- Pegang chuck bor penggantian SDS-plus (2) atau chuck bor pengencangan cepat (1) dengan seluruh tangan. Dorong chuck bor penggantian dengan diputar ke dudukan chuck bor (17) hingga terdengar bunyi mengunci yang jelas.
- Chuck bor penggantian mengunci secara otomatis. Periksa penguncian dengan menarik chuck bor.

Mengganti perkakas

Tutup pelindung debu (4) mencegah masuknya debu pengeboran ke dalam dudukan alat kerja selama pengoperasian. Saat menggunakan perkakas, pastikan tutup pelindung debu (4) tidak rusak.

- ▶ **Tutup pelindung debu yang rusak harus segera diganti. Disarankan untuk melakukannya di layanan pelanggan Bosch.**

Mengganti perkakas (SDS plus)

Memasang alat sisipan SDS-plus (lihat gambar E)

Dengan chuck bor SDS-plus, alat sisipan dapat diganti dengan mudah dan cepat tanpa menggunakan alat bantu. Alat sisipan SDS-plus harus dapat bergerak dengan bebas. Hal ini menimbulkan penyimpangan putaran sewaktu perkakas listrik berjalan pada kecepatan idle. Hal ini tidak memengaruhi ketepatan lubang bor karena mata bor memusatkan dengan sendirinya saat mengebor.

- **GBH 2-28 DFV:** Pasang chuck bor penggantian SDS plus (2).
- Bersihkan ujung alat sisipan dan lumasi dengan sedikit minyak.
- Pasang alat sisipan ke dalam dudukan alat kerja dengan diputar hingga terkunci dengan sendirinya.
- Periksa penguncian dengan menarik alat kerja.

Melepaskan alat sisipan SDS plus (lihat gambar F)

- Dorong selongsong pengunci (5) ke belakang dan lepaskan alat sisipan.

Mengganti perkakas (tanpa SDS plus)

(GBH 2-28 DFV)

Memasang alat sisipan (lihat gambar G)

Catatan: Jangan menggunakan perkakas tanpa SDS plus untuk mengebor benda keras atau memahat! Perkakas tanpa

SDS plus dan chuck bor akan menjadi rusak jika digunakan untuk mengebor benda keras dan memahat.

- Pasang chuck bor penggantian cepat (1).
- Pegang ring penahan (19) chuck bor penggantian pengencangan cepat dengan kuat. Buka dudukan alat kerja dengan memutar selongsong depan (18) hingga alat kerja dapat dimasukkan. Pegang ring penahan (19) dengan kuat dan putar selongsong depan (18) dengan kuat sesuai arah panah hingga terdengar bunyi klik dengan jelas.

- Periksa kedudukannya dengan menarik alat.

Catatan: Jika dudukan alat kerja dibuka hingga maksimal, bunyi klik dapat terdengar saat menutup dudukan alat kerja dan dudukan alat kerja tidak akan menutup.

Pada situasi ini, putar selongsong depan (18) satu kali berlawanan dengan arah panah. Lalu, dudukan alat kerja akan dapat ditutup.

- Putar switch getaran/penghenti putaran (11) ke posisi, "Pengeboran".

Melepaskan alat sisipan (lihat gambar H)

- Pegang ring penahan (19) chuck bor penggantian pengencangan cepat dengan kuat. Buka dudukan alat kerja dengan memutar selongsong depan (18) sesuai arah panah hingga alat kerja dapat dilepaskan.

Pengisapan debu dengan Saugfix (aksesori)

Pengisapan debu/serbuk

Debu dari bahan-bahan seperti cat yang mengandung timbal, beberapa jenis kayu, bahan mineral dan logam dapat berbahaya bagi kesehatan. Menyentuh atau menghirup debu tersebut dapat mengakibatkan reaksi alergi dan/atau penyakit saluran pernapasan bagi pengguna atau orang yang berada di dekatnya.

Beberapa debu tertentu seperti misalnya debu kayu pohon ek atau pohon fagus silvatica dianggap dapat mengakibatkan penyakit kanker, terutama dalam campuran dengan bahan-bahan tambahan untuk pengolahan kayu (kromat, obat pengawet kayu). Bahan-bahan yang mengandung asbes hanya boleh dikerjakan oleh orang-orang yang ahli.

- Gunakanlah hanya pengisap debu yang cocok untuk mengisap bahan yang dikerjakan.
- Pastikan terdapat ventilasi udara yang baik di tempat kerja.
- Dianjurkan untuk memakai masker anti debu dengan filter kelas P2.

Taatilah peraturan-peraturan untuk bahan-bahan yang dikerjakan yang berlaku di negara Anda.

- ▶ **Hindari debu yang banyak terkumpul di tempat kerja.**

Debu dapat tersulut dengan mudah.

Memasang alat pengisap (lihat gambar I)

Untuk pengisapan debu diperlukan Saugfix (aksesori). Saat mengebor, Saugfix akan bergerak ke tempat semula sehingga ujung Saugfix selalu ditahan rapat dengan permukaan benda kerja.

- Tekan tombol untuk mengatur pembatas kedalaman (12) dan lepaskan pembatas kedalaman (14). Tekan kembali tombol (12) dan pasang Saugfix dari depan ke dalam gagang tambahan (13).
- Sambungkan slang pengisap (diameter 19 mm, aksesoris) ke lubang pengisap (20).

Mesin pengisap debu harus sesuai dengan bahan yang dikerjakan.

Gunakan mesin pengisap khusus saat mengisap debu yang sangat berbahaya bagi kesehatan, pemicu kanker atau debu kering.

Mengatur kedalaman pengeboran pada Saugfix (lihat gambar J)

Kedalaman pengeboran yang diinginkan **X** juga dapat diatur pada Saugfix yang terpasang.

- Dorong alat sisipan SDS-plus ke dalam dudukan alat kerja SDS-plus (3) hingga maksimal. Alat kerja SDS-plus yang goyah dapat menyebabkan kesalahan dalam penyetelan kedalaman bor.
- Kendurkan baut kupu-kupu (24) pada Saugfix.
- Pasang perkakas listrik dengan kuat tanpa menghidupkannya pada permukaan yang akan dibor. Alat kerja SDS-plus harus mengenai permukaan yang dibor.
- Posisikan pipa pemandu (25) Saugfix pada penahannya sedemikian rupa hingga ujung Saugfix berada pada permukaan yang akan dibor. Jangan terus mendorong pipa pemandu (25) pada pipa teleskopik (23) dari yang diperlukan agar sebagian besar skala pada pipa teleskopik (23) tetap terlihat.
- Kencangkan kembali baut kupu-kupu (24). Kendurkan baut penjepit (21) pada pembatas kedalaman Saugfix.
- Geser pembatas kedalaman (22) pada pipa teleskopik (23) sedemikian rupa hingga jarak **X** yang ditunjukkan pada gambar sesuai dengan kedalaman pengeboran yang diinginkan.
- Kencangkan baut penjepit (21) di posisi ini.

Penggunaan

Pengoperasian pertama kali

- **Perhatikan tegangan listrik! Tegangan jaringan listrik harus sesuai dengan tegangan listrik yang tercantum pada label tipe perkakas listrik. Perkakas listrik dengan daya sebesar 230 V seperti yang diindikasikan pada label dapat juga dioperasikan pada daya 220 V.**

Mengatur mode pengoperasian

Pilih mode pengoperasian perkakas listrik menggunakan switch getaran/penghenti putaran (11).

- Untuk mengganti mode pengoperasian, tekan tombol rilis (10) dan putar switch getaran/penghenti putaran (11) ke posisi yang diinginkan hingga switch terdengar mengunci.

Catatan: Hanya ubah mode pengoperasian saat perkakas listrik dimatikan! Jika tidak, perkakas listrik dapat rusak.

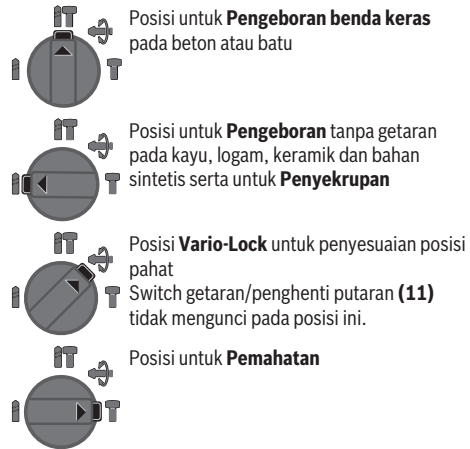

Menyetel arah putaran

Arah putaran perkakas listrik dapat diubah menggunakan switch arah putaran (7). Namun, hal ini tidak dapat dilakukan jika tombol on/off (9) ditekan.

- **Tekan switch arah putaran (7) hanya saat perkakas listrik sedang tidak beroperasi.**

Selalu atur arah putaran ke kanan untuk mengebor benda keras, mengebor biasa dan memahat.

- **Putaran ke kanan:** Putar switch arah putaran (7) pada kedua sisi ke posisi hingga maksimal.
- **Putaran ke kiri:** Putar switch arah putaran (7) pada kedua sisi ke posisi hingga maksimal.

Menyalakan/mematikan

- Untuk **menyalakan** perkakas listrik, tekan tombol on/off (9).
- Untuk **mengunci** tombol on/off (9), tekan dan tahan tombol serta tekan tombol pengunci (8).
- Untuk **mematikan** perkakas listrik, lepaskan tombol on/off (9). Jika tombol on/off (9) terkunci, tekan tombol terlebih dulu kemudian lepaskan.

Mengatur kecepatan putaran/tingkat getaran

- Atur kecepatan putaran/tingkat getaran dari perkakas listrik yang dinyalakan terus menerus bergantung pada seberapa kuat tombol on/off (9) ditekan.

Jika tombol on/off (9) ditekan lebih ringan, kecepatan putaran/tingkat getaran akan menjadi rendah. Jika tombol ditekan kuat, kecepatan putaran/tingkat getaran akan bertambah.

Petunjuk pengoperasian

- **Pasang perkakas listrik pada mur/sekrup hanya saat dalam keadaan mati.** Alat sisipan yang berputar dapat tergelincir.

Mengubah posisi pahat (Vario Lock)

Pahat dapat dikunci pada 40 posisi. Dengan demikian, posisi kerja yang optimal dapat diperoleh.

- Masukkan pahat ke dalam dudukan alat kerja.
- Putar switch getaran/penghenti putaran **(11)** ke posisi "Vario-Lock".
- Putar alat sisipan ke posisi pahat yang diinginkan.
- Putar switch getaran/penghenti putaran **(11)** ke posisi "Pemahatan". Dudukan alat kerja kemudian akan terkunci.
- Untuk memahat, atur arah putaran ke kanan.

Pemahatan dengan fungsi penguncian

Untuk memahat dalam waktu lama tanpa selalu menekan tombol on/off **(9)**, kunci tombol on/off pada mode pengoperasian "Pemahatan".

- Untuk **mengunci**, tekan tombol on/off **(9)** hingga maksimal dan tekan tombol pengunci **(8)** secara bersamaan.
- Untuk mematikan perkakas, tekan kembali tombol pengunci **(8)**.

Catatan: Jika mode pengoperasian diubah selama tombol on/off terkunci, perkakas listrik akan mati dengan sendirinya.

Peredaman getaran

 Peredaman getaran yang terintegrasi akan mengurangi getaran yang muncul.

- ▶ **Hentikan penggunaan perkakas listrik jika elemen peredaman rusak.**

Memasang mata obeng (lihat gambar K)

- ▶ **Pasang perkakas listrik pada mur/sekrup hanya saat dalam keadaan mati.** Alat sisipan yang berputar dapat tergelincir.

Untuk menggunakan mata obeng diperlukan holder universal **(26)** dengan batang pemasang SDS plus (aksesori).

- Bersihkan ujung batang pemasang dan lumasi dengan sedikit minyak.
- Pasang holder universal dengan cara diputar ke dalam dudukan alat kerja hingga terkunci dengan sendirinya.
- Periksa penguncian dengan menarik holder universal.
- Pasang mata obeng ke dalam holder universal. Hanya gunakan mata obeng yang sesuai dengan kepala sekrup.
- Untuk melepaskan holder universal, dorong selongsong pengunci **(5)** ke belakang dan lepaskan holder universal **(26)** dari dudukan alat kerja.

Perawatan dan servis

Perawatan dan pembersihan

- ▶ **Sebelum mulai dengan pekerjaan pada perkakas listrik, tariklah steker dari stopkontak.**
- ▶ **Perkakas listrik dan lubang ventilasi harus selalu dibersihkan agar perkakas dapat digunakan dengan baik dan aman.**

Jika kabel listrik harus diganti, pekerjaan ini harus dilakukan oleh **Bosch** atau Service Center untuk perkakas listrik **Bosch** resmi agar keselamatan kerja selalu terjamin.

- ▶ **Tutup pelindung debu yang rusak harus segera diganti. Direkomendasikan untuk melakukannya di layanan pelanggan Bosch.**

- Bersihkan dudukan alat kerja **(3)** setiap kali selesai digunakan.

Layanan pelanggan dan konsultasi penggunaan

Layanan pelanggan Bosch menjawab semua pertanyaan Anda tentang reparasi dan perawatan serta tentang suku cadang produk ini. Gambaran teknis (exploded view) dan informasi mengenai suku cadang dapat ditemukan di:

www.bosch-pt.com

Tim konsultasi penggunaan Bosch akan membantu Anda menjawab pertanyaan seputar produk kami beserta aksesorinya.

Jika Anda hendak menanyakan sesuatu atau memesan suku cadang, selalu sebutkan nomor model yang terdiri dari 10 angka dan tercantum pada label tipe produk.

Indonesia

PT Robert Bosch
Palma Tower 10th Floor
Jalan RA Kartini II-S Kaveling 6
Pondok Pinang, Kebayoran Lama
Jakarta Selatan 12310
Tel.: (021) 3005 5800
Fax: (021) 3005 5801
E-Mail: boschpowertools@id.bosch.com
www.bosch-pt.co.id

Cara membuang

Perkakas listrik, aksesoris, dan kemasan sebaiknya didaur ulang secara ramah lingkungan.



Jangan membuang perkakas listrik ke dalam sampah rumah tangga!

Tiếng Việt

Hướng dẫn an toàn

Cảnh báo Tổng quát Cách sử dụng An toàn Dụng cụ điện Cẩm tay

⚠ CẢNH BÁO **Đọc kỹ mọi cảnh báo an toàn và hướng dẫn.** Không tuân

thủ mọi cảnh báo và hướng dẫn được liệt kê dưới đây có thể bị điện giật, gây cháy và / hay bị thương tật nghiêm trọng.

Hãy giữ tất cả tài liệu về cảnh báo và hướng dẫn để tham khảo về sau.

Thuật ngữ "dụng cụ điện cầm tay" trong phần cảnh báo là để cập đến sự sử dụng dụng cụ điện cầm tay của bạn, loại sử dụng điện nguồn (có dây cắm điện) hay vận hành bằng pin (không dây cắm điện).

Khu vực làm việc an toàn

- ▶ **Giữ nơi làm việc sạch và đủ ánh sáng.** Nơi làm việc bừa bộn và tối tăm dễ gây ra tai nạn.
- ▶ **Không vận hành dụng cụ điện cầm tay trong môi trường dễ gây nổ, chẳng hạn như nơi có chất lỏng dễ cháy, khí đốt hay rác.** Dụng cụ điện cầm tay tạo ra các tia lửa nên có thể làm rác bén cháy hay bốc khói.
- ▶ **Không để trẻ em hay người đến xem đứng gần khi vận hành dụng cụ điện cầm tay.** Sự phân tâm có thể gây ra sự mất điều khiển.

An toàn về điện

- ▶ **Phích cắm của dụng cụ điện cầm tay phải thích hợp với ổ cắm.** Không bao giờ được cải biến lại phích cắm dưới mọi hình thức. Không được sử dụng phích tiếp hợp nối tiếp đất (dây mát). Phích cắm nguyên bản và ổ cắm đúng loại sẽ làm giảm nguy cơ bị điện giật.
- ▶ **Tránh không để thân thể tiếp xúc với đất hay các vật có bề mặt tiếp đất như đường ống, lò sưởi, hàng rào và tủ lạnh.** Có nhiều nguy cơ bị điện giật hơn nếu cơ thể bạn bị tiếp hay nối đất.
- ▶ **Không được để dụng cụ điện cầm tay ngoài mưa hay ở tình trạng ẩm ướt.** Nước vào máy sẽ làm tăng nguy cơ bị điện giật.
- ▶ **Không được làm dụng dây dẫn điện.** Không bao giờ được nắm dây dẫn để xách, kéo hay rút phích cắm dụng cụ điện cầm tay. Không để dây gần nơi có nhiệt độ cao, dầu nhớt, vật nhọn bén và bộ phận chuyển động. Làm hỏng hay cuộn rối dây dẫn làm tăng nguy cơ bị điện giật.
- ▶ **Khi sử dụng dụng cụ điện cầm tay ngoài trời, dùng dây nối thích hợp cho việc sử dụng ngoài trời.** Sử dụng dây nối thích hợp cho việc sử dụng ngoài trời làm giảm nguy cơ bị điện giật.
- ▶ **Nếu việc sử dụng dụng cụ điện cầm tay ở nơi ẩm ướt là không thể tránh được, dùng thiết bị ngắt mạch tự động (RCD) bảo vệ nguồn.** Sử dụng thiết bị ngắt mạch tự động RCD làm giảm nguy cơ bị điện giật.

An toàn cá nhân

- ▶ **Hãy tỉnh táo, biết rõ mình đang làm gì và hãy sử dụng ý thức khi vận hành dụng cụ điện cầm tay.** Không sử dụng dụng cụ điện cầm tay khi đang mệt mỏi hay đang bị tác động do chất gây nghiện, rượu hay dược phẩm gây ra. Một thoáng mất tập trung khi đang vận hành dụng cụ điện cầm tay có thể gây thương tích nghiêm trọng cho bản thân.
- ▶ **Sử dụng trang bị bảo hộ cá nhân.** Luôn luôn đeo kính bảo vệ mắt. Trang bị bảo hộ như khẩu trang, giày chống trượt, nón bảo hộ, hay dụng cụ bảo vệ tai khi được sử dụng đúng nơi đúng chỗ sẽ làm giảm nguy cơ thương tật cho bản thân.

- ▶ **Phòng tránh máy khởi động bất ngờ.** Bảo đảm công tắc máy ở vị trí tắt trước khi cắm vào nguồn điện và/hay lắp pin vào, khi nhắc máy lên hay khi mang xách máy. Ngáng ngón tay vào công tắc máy để xách hay kích hoạt dụng cụ điện cầm tay khi công tắc ở vị trí mở dễ dẫn đến tai nạn.
- ▶ **Lấy mọi chìa hay khóa điều chỉnh ra trước khi mở điện dụng cụ điện cầm tay.** Khóa hay chìa còn gắn dính vào bộ phận quay của dụng cụ điện cầm tay có thể gây thương tích cho bản thân.
- ▶ **Không rướn người.** Luôn luôn giữ tư thế đứng thích hợp và thăng bằng. Điều này tạo cho việc điều khiển dụng cụ điện cầm tay tốt hơn trong mọi tình huống bất ngờ.
- ▶ **Trang phục thích hợp.** Không mặc quần áo rộng lủng thùng hay mang trang sức. Giữ tóc, quần áo và găng tay xa khỏi các bộ phận chuyển động. Quần áo rộng lủng thùng, đồ trang sức hay tóc dài có thể bị cuốn vào các bộ phận chuyển động.
- ▶ **Nếu có các thiết bị đi kèm để nối máy hút bụi và các phụ kiện khác, bảo đảm các thiết bị này được nối và sử dụng tốt.** Việc sử dụng các thiết bị gom hút bụi có thể làm giảm các độc hại liên quan đến bụi gây ra.

Sử dụng và bảo dưỡng dụng cụ điện cầm tay

- ▶ **Không được ép máy.** Sử dụng dụng cụ điện cầm tay đúng loại theo đúng ứng dụng của bạn. Dụng cụ điện cầm tay đúng chức năng sẽ làm việc tốt và an toàn hơn theo đúng tiến độ mà máy được thiết kế.
- ▶ **Không sử dụng dụng cụ điện cầm tay nếu như công tắc không tắt và mở được.** Bất kỳ dụng cụ điện cầm tay nào mà không thể điều khiển được bằng công tắc là nguy hiểm và phải được sửa chữa.
- ▶ **Rút phích cắm ra khỏi nguồn điện và/hay pin ra khỏi dụng cụ điện cầm tay trước khi tiến hành bất kỳ điều chỉnh nào, thay phụ kiện, hay cất dụng cụ điện cầm tay.** Các biện pháp ngăn ngừa như vậy làm giảm nguy cơ dụng cụ điện cầm tay khởi động bất ngờ.
- ▶ **Cất giữ dụng cụ điện cầm tay không dùng tới nơi trẻ em không lấy được và không cho người chưa từng biết dụng cụ điện cầm tay hay các hướng dẫn này sử dụng dụng cụ điện cầm tay.** Dụng cụ điện cầm tay nguy hiểm khi ở trong tay người chưa được chỉ cách sử dụng.
- ▶ **Bảo quản dụng cụ điện cầm tay.** Kiểm tra xem các bộ phận chuyển động có bị sai lệch hay kẹt, các bộ phận bị rạn nứt và các tình trạng khác có thể ảnh hưởng đến sự vận hành của máy. Nếu bị hư hỏng, phải sửa

chữa máy trước khi sử dụng. Nhiều tai nạn xảy ra do bảo quản dụng cụ điện cầm tay tối.

- ▶ **Giữ các dụng cụ cất bên và sạch.** Bảo quản đúng cách các dụng cụ cất có cạnh cắt bén làm giảm khả năng bị kẹt và dễ điều khiển hơn.
- ▶ **Sử dụng dụng cụ điện cầm tay, phụ kiện, đầu cài v. v., đúng theo các chỉ dẫn này, hãy lưu ý đến điều kiện làm việc và công việc phải thực hiện.** Sự sử dụng dụng cụ điện cầm tay khác với mục đích thiết kế có thể tạo nên tình huống nguy hiểm.

Bảo dưỡng

- ▶ **Đưa dụng cụ điện cầm tay của bạn đến thợ chuyên môn để bảo dưỡng, chỉ sử dụng phụ tùng đúng chủng loại để thay.** Điều này sẽ đảm bảo sự an toàn của máy được giữ nguyên.

Cảnh báo An toàn Khoan búa

Hướng dẫn an toàn cho mọi hoạt động

- ▶ **Đeo bảo vệ tai.** Tiếp xúc với tiếng ồn có thể làm mất khả năng nghe.
- ▶ **Sử dụng tay nắm phụ.** Mất điều khiển có thể gây ra thương tích cho người.
- ▶ **Chàng dụng cụ đúng cách trước khi sử dụng.** Công cụ này tạo ra mô-men xoắn đầu ra cao và nếu không chàng dụng cụ đúng cách trong lúc vận hành, thì việc mất kiểm soát có thể dẫn đến thương tích cho người.
- ▶ **Cắm vào bề mặt cầm nắm cách điện của dụng cụ điện cầm tay khi thực hiện một thao tác tại vị trí phụ kiện cắt hoặc dụng cụ kẹp có thể tiếp xúc với dây điện ngầm hoặc dây nguồn của chính nó.** Phụ kiện cắt hoặc dụng cụ kẹp tiếp xúc với dây "có điện" có thể làm cho các phần kim loại hở của dụng cụ điện cầm tay "có điện" và có thể gây ra điện giật cho người vận hành.

Hướng dẫn an toàn khi sử dụng các mũi khoan dài

- ▶ **Không vận hành ở tốc độ cao hơn tốc độ tối đa cho phép của mũi khoan.** Ở tốc độ cao hơn, mũi khoan có thể bị cong nếu cho phép xoay tự do mà không cho tiếp xúc với phôi gia công, dẫn đến thương tích cho người.
- ▶ **Luôn khởi động khoan ở tốc độ thấp và với đầu mũi khoan tiếp xúc với phôi gia công.** Ở tốc độ cao hơn, mũi khoan có thể bị cong nếu cho phép xoay tự do mà không cho tiếp xúc với phôi gia công, dẫn đến thương tích cho người.
- ▶ **Chỉ dùng áp lực vào đường trực tiếp bằng mũi khoan và không dùng áp lực dư.** Các mũi khoan có thể cong, gây ngắt hoặc mất kiểm soát, dẫn đến thương tích cho người.

Các cảnh báo phụ thêm

- ▶ **Sử dụng (các) tay cầm phụ, nếu được cung cấp kèm theo dụng cụ.** Mất điều khiển có thể gây ra thương tích cho người.
- ▶ **Giữ máy thật chắc bằng cả hai tay trong khi làm việc và luôn luôn giữ tư thế đứng cho thích hợp và cân bằng.** Dùng hai tay để điều khiển máy thì an toàn hơn.
- ▶ **Tắt dụng cụ điện ngay nếu phụ tùng bị chặn.** Hãy chuẩn bị cho những mô-men phản ứng cao, mà gây ra sự dội ngược. Phụ tùng bị chặn, nếu dụng cụ điện bị quá tải hoặc bị kẹt trong phôi gia công cần gia công.
- ▶ **Kẹp chặt vật gia công.** Vật gia công được kẹp bằng một thiết bị kẹp hay bằng ê-tô thì vững chắc hơn giữ bằng tay.
- ▶ **Dùng thiết bị dò tìm thích hợp để xác định nếu có các công trình công cộng lắp đặt ngầm trong khu vực làm việc hay liên hệ với Cty công trình công cộng địa phương để nhờ hỗ trợ.** Dụng cụ dò tìm đường dẫn điện có thể gây ra hỏa hoạn và điện giật. Làm hư hại đường dẫn khí ga có thể gây nổ. Làm thủng đường dẫn nước gây hư hỏng tài sản hay có khả năng gây ra điện giật.
- ▶ **Luôn luôn đợi cho máy hoàn toàn ngừng hẳn trước khi đặt xuống.** Dụng cụ lắp vào máy có thể bị kẹp chặt dẫn đến việc dụng cụ điện cầm tay bị mất điều khiển.

Mô Tả Sản Phẩm và Đặc Tính Kỹ Thuật



Đọc kỹ mọi cảnh báo an toàn và mọi hướng dẫn. Không tuân thủ mọi cảnh báo và hướng dẫn được liệt kê dưới đây có thể bị điện giật, gây cháy và / hay bị thương tật nghiêm trọng.

Xin lưu ý các hình minh họa trong phần trước của hướng dẫn vận hành.

Sử dụng đúng cách

Máy được thiết kế để khoan có động tác búa vào bê-tông, gạch và công trình nề, cũng như dành cho công việc đục không nhiều. Cũng tương tự phù hợp để khoan mà không cần va đập vào gỗ, kim loại, sứ và chất dẻo. Máy có bộ phận điều khiển điện tử và quay được chiều phải/trái cũng thích hợp cho việc bắt vít.

Các bộ phận được minh họa

Sự đánh số các biểu trưng của sản phẩm là để tham khảo hình minh họa của máy trên trang hình ảnh.

- (1) Mâm cặp thay nhanh không chia (GBH 2-28 DFW)

- | | |
|---|---|
| <p>(2) Mâm cặp thay nhanh SDS-plus
(GBH 2-28 DFV)</p> <p>(3) Phần lắp dụng cụ SDS-plus</p> <p>(4) Chụp ngăn bụi</p> <p>(5) Vòng khóa</p> <p>(6) Vòng khóa mâm cặp thay nhanh
(GBH 2-28 DFV)</p> <p>(7) Gạc vận chuyển đổi chiều quay</p> <p>(8) Nút khoá giữ chế độ tự-chạy của công tắc bật / tắt</p> <p>(9) Công tắc bật/tắt</p> <p>(10) Nút nhả khóa để sử dụng gạc chọn phương thức hoạt động</p> <p>(11) Gạc Chọn Chế Độ Hoạt Động</p> <p>(12) Nút điều chỉnh cho cỡ định độ sâu</p> <p>(13) Tay nắm phụ (có bề mặt nắm cách điện)</p> <p>(14) Cỡ định độ sâu</p> <p>(15) Tay nắm (bề mặt nắm cách điện)</p> | <p>(16) Rãnh Khóa Nhận Dạng</p> <p>(17) Thiết bị tiếp hợp đầu cặp mũi khoan
(GBH 2-28 DFV)</p> <p>(18) Khớp vòng ngoài của mâm cặp thay nhanh không chia (GBH 2-28 DFV)</p> <p>(19) Vòng giữ của mâm cặp thay nhanh không chia (GBH 2-28 DFV)</p> <p>(20) Lỗ hút phụ kiện gá lắp hút bụi ^{A)}</p> <p>(21) Vít kẹp phụ kiện gá lắp hút bụi ^{A)}</p> <p>(22) Cỡ định độ sâu phụ kiện gá lắp hút bụi ^{A)}</p> <p>(23) Ống lồng phụ kiện gá lắp hút bụi ^{A)}</p> <p>(24) Vít tai hồng phụ kiện gá lắp hút bụi ^{A)}</p> <p>(25) Ống dẫn phụ kiện gá lắp hút bụi ^{A)}</p> <p>(26) Phần lắp đầu gài phổ thông với chuỗi SDS-plus^{A)}</p> |
|---|---|
- A) Phụ tùng được trình bày hay mô tả không phải là một phần của tiêu chuẩn hàng hóa được giao kèm theo sản phẩm. Bạn có thể tham khảo tổng thể các loại phụ tùng, phụ kiện trong chương trình phụ tùng của chúng tôi.

Thông số kỹ thuật

Khoan Búa		GBH 2-28 D		GBH 2-28 DV	
Mã số máy		3 611 B67 0C. 3 611 B67 0L.	3 611 B67 0K. 3 611 B67 08.	3 611 B67 1F.	3 611 B67 10.
Mâm cặp thay nhanh		-	-	-	-
Công suất vào danh định	W	850	820	850	820
Tần suất đập	min ⁻¹	0-5100	0-5100	0-5100	0-5100
Năng lượng va đập của từng hành trình dựa theo EPTA-Procedure 05:2016	J	3,2	3,2	3,2	3,2
Tốc độ danh định	min ⁻¹	0-1300	0-1300	0-1300	0-1300
Phần lắp dụng cụ		SDS-plus	SDS-plus	SDS-plus	SDS-plus
Đường kính cổ trục	mm	50	50	50	50
đường kính mũi khoan tối đa					
- Bê-tông	mm	28	28	28	28
- Công trình nề (với mũi khoan lõi)	mm	68	68	68	68
- Thép	mm	13	13	13	13
- Gỗ	mm	30	30	30	30
Trọng lượng theo Quy trình EPTA-Procedure 01:2014	kg	2,9	2,9	2,9	2,9
Cấp độ bảo vệ		□/II	□/II	□/II	□/II

Khoan Búa		GBH 2-28 DVF	
Mã số máy		3 611 B67 2C. 3 611 B67 2L.	3 611 B67 2K. 3 611 B67 28.
Mâm cặp thay nhanh		●	●
Công suất vào danh định	W	850	820
Tần suất đập	min ⁻¹	0-5100	0-5100
Năng lượng va đập của từng hành trình dựa theo EPTA-Procedure 05:2016	J	3,2	3,2
Tốc độ danh định	min ⁻¹	0-1300	0-1300
Phần lắp dụng cụ		SDS-plus	SDS-plus
Đường kính cổ trục	mm	50	50
đường kính mũi khoan tối đa			
– Bê-tông	mm	28	28
– Công trình nề (với mũi khoan lõi)	mm	68	68
– Thép	mm	13	13
– Gỗ	mm	30	30
Trọng lượng theo Qui trình EPTA-Procedure 01:2014	kg	3,1	3,1
Cấp độ bảo vệ		□ / II	□ / II

Các giá trị đã cho có hiệu lực cho điện thế danh định [U] 230 V. Đối với điện thế thấp hơn và các loại máy dành riêng cho một số quốc gia, các giá trị này có thể thay đổi.

Sự lắp vào

- ▶ Trước khi tiến hành bất cứ việc gì trên máy, kéo phích cắm điện nguồn ra.

Tay nắm phụ

- ▶ Chỉ vận hành máy của bạn khi đã gắn tay nắm phụ (13).

Xoay tay nắm phụ (xem hình A)

Bạn có thể xoay tay nắm phụ (13) tùy ý, để có tư thế làm việc an toàn và ít mỏi.

- Xoay phần tay cầm dưới của tay nắm phụ (13) ngược chiều kim đồng hồ và xoay tay nắm phụ (13) vào vị trí mong muốn. Sau đó xoay mẫu tay cầm dưới của tay cầm phụ (13) theo chiều kim đồng hồ để siết chặt.

Hãy lưu ý rằng nẹp định vị của tay nắm phụ được đặt trong rãnh nằm trên vỏ máy đúng như chủ định.

Điều chỉnh độ sâu lỗ khoan (xem Hình B)

Nhờ chốt chặn độ sâu (14), bạn có thể xác định được độ sâu lỗ khoan X mong muốn.

- Bấm nút điều chỉnh cỡ định độ sâu (12) và điều chỉnh cỡ định độ sâu trên tay nắm phụ (13). Rãnh trên cỡ định độ sâu (14) phải hướng lên trên.

- Hãy đẩy dụng cụ gài SDS-plus vào khe cắm dụng cụ cho tới cỡ chặn (3). Nếu không, sự chuyển dịch của dụng cụ khoan SDS-plus có thể dẫn đến sự điều chỉnh sai độ sâu khoan.
- Kéo chốt chặn độ sâu ra xa sao cho khoảng cách giữa mũi khoan và đầu chốt chặn độ sâu phù hợp với độ sâu lỗ khoan mong muốn X.

Chọn Lựa Mâm Cặp Khoan và Dụng Cụ

Để đục hay khoan búa, cần phải sử dụng loại dụng cụ SDS-plus để lắp vào mâm cặp khoan SDS-plus.

Để khoan không đập trên gỗ, kim loại, sứ và nhựa cũng như để bắt vít, cần dùng các dụng cụ không SDS-plus (ví dụ khoan có trục hình trụ). Cần sử dụng mâm cặp không dùng chìa cho các dụng cụ khoan nói trên.

Tháo/Lắp Mâm Cặp Thay Nhanh

(GBH 2-28 DVF)

Tháo đầu cặp mũi khoan vành răng (xem Hình C)

- Kéo vòng khóa mâm cặp thay nhanh (6) ra phía sau, giữ chặt tại vị trí và tháo mâm cặp thay nhanh SDS-plus (2) hoặc mâm cặp thay nhanh không chìa (1) hướng về phía trước.
- Sau khi tháo ra, hãy bảo vệ cho mâm cặp thay ra không bị bẩn.

Lắp mâm cặp thay nhanh (xem hình D)

- ▶ **Chỉ sử dụng trang thiết bị gốc và tuân thủ số lượng rãnh Khía nhận Dạng (16). Chỉ cho phép dùng mâm cặp thay nhanh với hai rãnh khía nhận dạng.** Nếu sử dụng mâm cặp thay nhanh không phù hợp với dụng cụ điện này, dụng cụ gài có thể bị rơi khi vận hành.
- Trước khi lắp vào, lau sạch mâm cặp thay nhanh và bôi một lớp mỏng dầu bôi trơn lên cán chuỗi.
- Cắm mâm cặp thay nhanh không chia (1) hoặc mâm cặp thay nhanh không chia (1) bằng cả bàn tay. Hãy đẩy mâm cặp thay nhanh lên thiết bị tiếp hợp đầu cặp mũi khoan (17), cho đến khi bạn nghe thấy tiếng khớp vào.
- Mâm cặp thay nhanh tự động khóa lại. Kiểm tra hiệu quả khóa bằng cách kéo thử mâm cặp thay nhanh.

Thay Dụng Cụ

Chụp bảo vệ ngăn bụi (4) giúp ngăn cản phần lớn sự xâm nhập của bụi khoan vào dụng cụ trong thời gian hoạt động. Khi lắp dụng cụ vào, hãy lưu ý rằng chụp bảo vệ ngăn bụi (4) không bị làm hư hỏng.

- ▶ **Thay chụp ngăn bụi bị hỏng ngay lập tức. Chúng tôi khuyến nghị việc thay thế này do một đại lý phục vụ hậu mãi thực hiện.**

Thay đổi dụng cụ (SDS-plus)**Thay dụng cụ gài SDS-plus (xem hình E)**

Mâm cặp khoan SDS-plus cho phép thay đổi dụng cụ khoan được đơn giản và tiện lợi mà không cần tới các dụng cụ phụ trợ khác.

Theo như yêu cầu của hệ thống, dụng cụ khoan SDS-plus có thể chuyển động tự do. Điều này tạo ra sự đảo tảo tròn khi chạy không tải ở một mức nào đó. Việc này không làm ảnh hưởng đến độ chính xác của lỗ khoan, vì mũi khoan định tâm của chính nó trong khi khoan.

- **GBH 2-28 DFV:** Lắp mâm cặp thay nhanh SDS-plus (2) vào.
- Làm sạch và thoa một lớp mỏng dầu bôi trơn lên chuỗi của dụng cụ.
- Lắp dụng cụ vào bằng cách xoay vận dụng cụ vào ổ lắp dụng cụ cho đến khi tự ăn vào khớp.
- Kiểm tra xem đã cài chắc chưa bằng cách kéo thử dụng cụ ra.

Tháo dụng cụ gài SDS-plus (xem Hình F)

- Đẩy vòng khóa (5) về phía sau và tháo phụ tùng.

Thay đổi dụng cụ (không SDS-plus)

(GBH 2-28 DFV)

Thay phụ tùng (xem hình G)

Hướng dẫn: Không sử dụng các dụng cụ không SDS-plus để khoan búa hoặc đục! Khoan hay đục

có động tác búa làm hỏng dụng cụ không phải loại SDS-plus và mâm cặp của chúng.

- Lắp mâm cặp thay nhanh không chia (1).
- Hãy giữ chặt vòng giữ (19) của mâm cặp thay nhanh không chia. Hãy mở phần lắp dụng cụ bằng cách xoay bạc lót trước (18) cho đến khi dụng cụ có thể được lắp. Giữ chặt vòng giữ (19) và xoay bạc lót phía trước (18) bằng lực mạnh theo hướng mũi tên, cho đến khi nghe thấy tiếng khớp.
- Kiểm tra xem đã vào chắc chưa bằng cách kéo thử dụng cụ ra.

Hướng dẫn: Nếu bộ gá dụng cụ đã được mở ra cho đến khi dừng lại, thì khi xoay bộ gá dụng cụ có thể nghe thấy tiếng kêu rắc và bộ gá dụng cụ không tự đóng lại.

Trong trường hợp này, hãy xoay (18) một lần ống bọc ngoài phía trước ngược hướng mũi tên. Sau đó, bộ gá dụng cụ có thể được đóng lại.

- Vận công tắc dừng xoay/dừng đập (11) vào vị trí „Khoan“.

Thay (xem Hình H)

- Hãy giữ chặt vòng giữ (19) của mâm cặp thay nhanh không chia. Hãy mở phần lắp dụng cụ bằng cách xoay bạc lót trước (18) theo hướng mũi tên cho đến khi dụng cụ có thể được tháo.

Hệ thống hút bụi có phụ kiện gá lắp hút bụi (Phụ kiện)**Hút Dăm/Bụi**

Mạt bụi từ các vật liệu được sơn phủ ngoài có chứa chì trên một số loại gỗ, khoáng vật và kim loại có thể gây nguy hại đến sức khoẻ con người. Dụng cụ chạm hay hít thở các bụi này có thể làm người sử dụng hay đứng gần bị dị ứng và/hoặc gây nhiễm trùng hệ hô hấp.

Một số hạt bụi có thể, ví dụ như bụi gỗ sồi hay đậu, được xem là chất gây ung thư, đặc biệt là có liên quan đến các chất phụ gia dùng xử lý gỗ (chất cromat, chất bảo quản gỗ). Có thể chỉ nên để thợ chuyên môn gia công các loại vật liệu có chứa amiăng.

- Cách xa ở mức có thể được, sử dụng hệ thống hút thích hợp cho loại vật liệu.
- Tạo không khí thông thoáng nơi làm việc.
- Khuyến nghị nên mang mặt nạ phòng độc có bộ lọc cấp P2.

Tuân thủ các qui định của quốc gia bạn liên quan đến loại vật liệu gia công.

▶ Tránh không để rác tích tụ tại nơi làm việc.

Rác có thể dễ dàng bắt lửa.

Lắp thiết bị hút (xem hình I)

Để hút bụi, cần phải có phụ kiện gá lắp hút bụi (phụ kiện). Khi khoan, phụ kiện gá lắp hút bụi thu lại vì thế đầu của phần gá lắp luôn luôn kề sát với bề mặt lỗ khoan.

- Bấm nút điều chỉnh cỡ định độ sâu (12) và tháo cỡ định độ sâu (14). Bấm lại nút (12) và lắp phụ kiện gá lắp hút bụi từ phía trước vào tay nắm phụ (13).
 - Hãy nối ống hút (Đường kính 19 mm, phụ kiện) với lỗ hút (20) của phụ kiện gá lắp hút bụi.
- Máy hút bụi phải thích hợp dành cho loại vật liệu đang gia công.

Khi hút bụi khô loại đặc biệt gây nguy hại đến sức khỏe hoặc gây ra ung thư, hãy sử dụng máy hút bụi loại chuyên dụng.

Điều chỉnh độ sâu lỗ khoan ở phụ kiện gá lắp hút bụi (xem hình J)

Bạn có thể cố định độ sâu lỗ khoan mong muốn X khi lắp phụ kiện gá lắp hút bụi.

- Hãy đẩy dụng cụ gài SDS-plus vào khe cắm dụng cụ cho tới cỡ chặn (3). Nếu không, sự chuyển dịch của dụng cụ khoan SDS-plus có thể dẫn đến sự điều chỉnh sai độ sâu khoan.
- Hãy nhả vít tai hồng (24) ở phụ kiện gá lắp hút bụi.
- Không mở máy dụng cụ điện lên, ấn mạnh xuống ngay vị trí khoan. Dụng cụ khoan SDS-plus phải áp mặt lên trên bề mặt.
- Hãy di chuyển ống dẫn (25) của phụ kiện gá lắp hút bụi vào giá đỡ sao cho đầu phụ kiện gá lắp hút bụi nằm trên bề mặt cần khoan. Không đẩy ống dẫn (25) qua ống lồng (23) như mức cần thiết, để một phần lớn hết mức có thể của thước nằm trên ống lồng (23).
- Siết chặt lại vít tai hồng (24). Hãy nhả vít kẹp (21) ở cỡ định độ sâu của phụ kiện gá lắp hút bụi.
- Hãy di chuyển cỡ định độ sâu (22) trên ống lồng (23), sao cho khoảng cách đã hiển thị trong hình ảnh X tương ứng với độ sâu lỗ khoan mong muốn.
- Hãy siết chặt vít kẹp (21) tại vị trí này.

Vận Hành

Bắt Đầu Vận Hành

- ▶ **Hãy cẩn thận với nguồn điện! Điện thế nguồn phải đúng với điện thế đã ghi rõ trên nhãn máy. Dụng cụ điện được ghi 230 V cũng có thể được vận hành ở 220 V.**

Điều chỉnh chế độ vận hành

Bằng công tắc dừng xoay/dừng đập (11) hãy chọn chế độ vận hành của dụng cụ điện.

- Hãy nhấn nút mở khóa (10) để thay đổi chế độ vận hành và xoay công tắc dừng xoay/dừng đập (11) vào vị trí mong muốn, đến khi vào khớp.

Hướng dẫn: Chỉ thay đổi chế độ vận hành khi dụng cụ điện tắt! Nếu không, máy có thể bị làm hỏng.

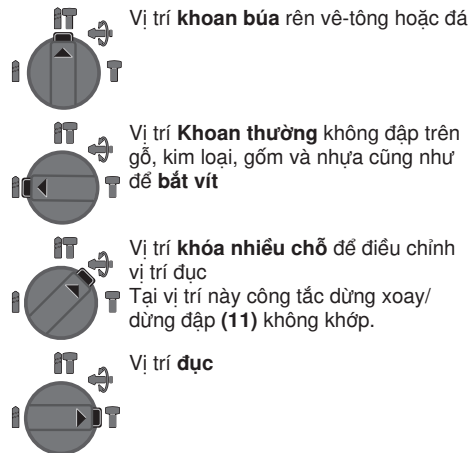

Đảo Chiều Quay

Với gạt vận chuyển đổi chiều quay (7) bạn có thể thay đổi hướng xoay của dụng cụ điện. Tuy nhiên, việc này không thực hiện được khi công tắc Tắt/Mở được nhấn (9).

- ▶ **Chỉ kích hoạt gạt vận chuyển đổi chiều quay (7) khi dụng cụ điện đã ngừng chạy.**

Luôn luôn chỉnh đặt chiều quay để khoan búa, khoan thường và đục về chiều quay phải.

- **Xoay theo chiều kim đồng hồ:** Xoay gạt vận chuyển đổi chiều quay (7) ở hai bên vào vị trí ← cho đến cỡ chặn.
- **Xoay ngược chiều kim đồng hồ:** Xoay gạt vận chuyển đổi chiều quay (7) ở hai bên vào vị trí → cho đến cỡ chặn.

Bật/tắt

- Để **bật** dụng cụ điện cầm tay, bạn hãy nhấn công tắc bật/tắt (9).
- Để **khóa** công tắc bật/tắt (9), hãy bấm giữ công tắc và ấn thêm nút khóa giữ (8).
- Để **tắt** dụng cụ điện cầm tay hãy nhả công tắc bật/tắt (9). Khi công tắc bật/tắt bị khóa (9) hãy nhấn nó và sau đó nhả ra.

Chỉnh đặt Tốc độ/Tần suất Đập

- Hãy liên tục điều chỉnh tốc độ/tần suất đập của dụng cụ điện đang bật tùy theo mức độ bấm công tắc Tắt/Mở mạnh hay nhẹ (9).

Bấm nhẹ công tắc Tắt/Mở (9) sẽ cho tốc độ/tần suất đập thấp. Lực áp mạnh hơn lên công tắc làm tăng tốc độ và tần suất đập.

Hướng Dẫn Sử Dụng

- ▶ **Chỉ đặt dụng cụ điện đã tắt lên đai ốc/vít.**
Dụng cụ đang quay có thể bị tuột ra.

Thay Đổi Vị Trí Đục (Khóa nhiều vị trí)

Bạn có thể khóa mũi đục vào **40** các vị trí. Nhờ như vậy, ta có thể tạo tư thế thao tác tốt nhất cho từng ứng dụng.

- Lắp mũi đục vào trong ổ lắp dụng cụ.
- Vận công tắc dừng xoay/dừng đập **(11)** vào vị trí „Khóa nhiều vị trí“.
- Xoay phần lắp dụng cụ về vị trí đục theo yêu cầu.
- Vận công tắc dừng xoay/dừng đập **(11)** vào vị trí „Đục“. Giá đỡ dụng cụ được khóa.
- Để đục, chỉnh đặt chiều quay về chiều quay phải.

Đục với chức năng khóa giữ

Để đục lâu hơn mà không cần liên tục nhấn công tắc bật/tắt **(9)**, hãy khóa giữ công tắc bật/tắt trong chế độ vận hành „Đục“.

– Để **khóa** hãy nhấn công tắc bật/tắt **(9)** cho đến cứ chặn và đồng thời nhấn nút khóa giữ **(8)**.

– Để **tắt**, bạn hãy nhấn lại nút khóa giữ **(8)**.

Lưu ý: Hãy chuyển sang chế độ vận hành khác, trong khi công tắc bật/tắt được khóa, dụng cụ điện được tắt.

Bộ phận giảm chấn

 Bộ phận giảm chấn tích hợp sẽ giảm các rung động xuất hiện.

- ▶ **Không được tiếp tục sử dụng dụng cụ điện khi bộ phận giảm chấn đã bị hỏng.**

Lắp đầu chia vận vít (xem Hình K)

- ▶ **Chỉ đặt dụng cụ điện đã tắt lên đai ốc/vít.**

Dụng cụ đang quay có thể bị tuột ra.

Để sử dụng đầu chia vận vít bạn cần có phần lắp đầu gài phổ thông **(26)** với chuỗi tiếp hợp SDS-plus (Phụ kiện).

- Làm sạch cán chuỗi của chuỗi tiếp hợp và bôi một lớp mỏng dầu bôi trơn lên.
- Lắp phần lắp đầu chia vận vít phổ thông bằng động tác xoay vào trong phần lắp dụng cụ cho đến khi được tự động khóa lại.
- Kiểm tra hiệu quả khóa bằng cách kéo thử phần lắp đầu gài phổ thông ra.
- Lắp đầu gài vận vít vào trong phần lắp đầu gài phổ thông. Chỉ sử dụng đầu gài vận vít vừa với đầu vít.
- Để tháo phần lắp đầu gài phổ thông hãy đẩy vòng Khóa **(5)** ra phía sau và tháo phần lắp đầu gài phổ thông **(26)** ra khỏi phần lắp dụng cụ.

Bảo Dưỡng và Bảo Quản

Bảo Dưỡng Và Làm Sạch

- ▶ **Trước khi tiến hành bất cứ việc gì trên máy, kéo phích cắm điện nguồn ra.**

- ▶ **Để được an toàn và máy hoạt động đúng chức năng, luôn luôn giữ máy và các khe thông gió được sạch.**

Nếu như cần phải thay dây dẫn điện thì công việc này phải do hãng **Bosch**, hay một đại lý được **Bosch** ủy nhiệm thực hiện để tránh gặp sự nguy hiểm do mất an toàn.

- ▶ **Thay chụp ngăn bụi bị hỏng ngay lập tức. Chúng tôi khuyến nghị việc thay thế này do một đại lý phục vụ hậu mãi thực hiện.**

– Hãy làm sạch phần lắp dụng cụ **(3)** sau khi dùng.

Dịch vụ hỗ trợ khách hàng và tư vấn sử dụng

Bộ phận phục vụ hàng sau khi bán của chúng tôi trả lời các câu hỏi liên quan đến việc bảo dưỡng và sửa chữa các sản phẩm cũng như phụ tùng thay thế của bạn. Sơ đồ mô tả và thông tin về phụ tùng thay thế cũng có thể tra cứu theo dưới đây:

www.bosch-pt.com

Đội ngũ tư vấn sử dụng của Bosch sẽ giúp bạn giải đáp các thắc mắc về sản phẩm và phụ kiện.

Trong tất cả các phản hồi và đơn đặt phụ tùng, xin vui lòng luôn luôn nhập số hàng hóa 10 chữ số theo nhãn của hàng hóa.

Việt Nam

CN CÔNG TY TNHH BOSCH VIỆT NAM TẠI TP.HCM

Tầng 14, Ngôi Nhà Đức, 33 Lê Duẩn
Phường Bến Nghé, Quận 1, Thành Phố Hồ Chí Minh

Tel.: (028) 6258 3690

Fax: (028) 6258 3692 - 6258 3694

Hotline: (028) 6250 8555

Email: tuvankhachhang-pt@vn.bosch.com

www.bosch-pt.com.vn

www.baohanhbosch-pt.com.vn

Campuchia

Công ty TNHH Robert Bosch (Campuchia)

Đơn nguyên 8BC, GT Tower, Tầng 08, Đường 169,

Tiếp Khắc Blvd, Sangkat Veal Vong,

Khan 7 Makara, Phnom Penh

VAT TIN: 100 169 511

Tel.: +855 23 900 685

Tel.: +855 23 900 660

www.bosch.com.kh

Sự thải bỏ

Máy, linh kiện và bao bì phải được phân loại để tái chế theo hướng thân thiện với môi trường.



Không được thải bỏ dụng cụ điện vào chung với rác sinh hoạt!

