



Cisco Catalyst 9300 Series Switches Hardware Installation Guide

First Published: 2017-06-20

Last Modified: 2023-02-14

Americas Headquarters

Cisco Systems, Inc.
170 West Tasman Drive
San Jose, CA 95134-1706
USA
<http://www.cisco.com>
Tel: 408 526-4000
800 553-NETS (6387)
Fax: 408 527-0883



CONTENTS

PREFACE

Preface ix

- Document Conventions ix
- Related Documentation xi
- Obtaining Documentation and Submitting a Service Request xi

CHAPTER 1

Product Overview 1

- Switch Models 2
- Front Panel Components 5
 - 10/100/1000 Ports 11
 - PoE, PoE+, Cisco UPOE and Cisco UPOE+ Ports 11
 - Multigigabit Ethernet Ports 11
 - Management Ports 12
 - USB Type A and Type C Ports 13
 - Uplink Ports 13
 - LEDs 14
 - USB Console LED 15
 - System LED 15
 - Active LED 15
 - STACK LED 16
 - PoE LED 16
 - XPS LED 17
 - S-PWR LED 17
 - Port LEDs and Modes 18
 - Beacon LED 20
 - Network Module LEDs 21

Rear Panel	21
RFID Tag	25
RJ-45 Console Port LED	25
StackWise Ports	25
Power Supply Modules	25
Fan Module	28
StackPower Connector	29
USB 3.0 SSD Port	29
Ethernet Management Port	30
RJ-45 Console Port	30
Network Configurations	30

CHAPTER 2**Preparing for Installation** 31

Safety Warnings	31
Installation Guidelines	33
Site Requirements	34
Temperature	35
Air Flow	35
Humidity	36
Altitude	36
Dust and Particles	36
Air Quality	37
Corrosion	37
EMI and Radio Frequency Interference	38
Shock and Vibration	39
Power Source Interruptions	39
System Grounding	40
Maintaining Safety with Electricity	42
Preventing ESD Damage	43

CHAPTER 3**Installing a Switch** 45

Shipping Box Contents	45
Tools and Equipment	47
Verifying Switch Operation	47

Planning a Switch Data Stack	47
Switch Stacking and Power Stacking Guidelines	48
Data Stack Cabling Configurations	48
Data Stack Bandwidth and Partitioning Examples	49
Power-On Sequence for Switch Stacks	50
Planning a StackPower Stack	51
StackPower Stacking Guidelines	51
StackPower Cabling Configurations	52
StackPower Partitioning Examples	53
Installing the Switch	54
Rack-Mounting	54
Attaching the Rack-Mount Brackets	56
Mounting the Switch in a Rack	58
Installing the Switch on a Table or Shelf	59
After Switch Installation	60
Connecting the StackWise Cables	60
Connecting a StackWise-320 Cable	60
Connecting a StackWise-480/1T Cable	62
Connecting to the StackPower Ports	64
Installing a Network Module in the Switch	64
Installing and Removing Cisco Pluggable Transceiver Modules	64
Connecting Devices to the Ethernet Ports	64
10/100/1000/Multigigabit Ethernet Port Connections	65
Auto-MDIX Connections	65
PoE+ and Cisco UPOE/UPOE+ Port Connections	65

CHAPTER 4
Installing a Network Module 67

Network Modules Overview	67
Installing a Network Module in the Switch	68
Safety Warnings	68
Installing a Network Module	68
Network Module Port Configurations	72
C9300-NM-2Q Module	72
C9300-NM-4G Module	73

C9300-NM-4M Module	73
C9300-NM-2Y Module	74
C9300-NM-8X Module	74
C9300X-NM-2C Module	74
C9300X-NM-4C Module	74
C9300X-NM-8M Module	75
C9300X-NM-8Y Module	75
Removing a Network Module	76
Installing and Removing Cisco Transceiver Modules	77
Installing a Cisco Pluggable Transceiver Module	77
Removing Cisco Pluggable Transceiver Modules	78
Finding the Network Module Serial Number	79

CHAPTER 5
Installing a Power Supply 81

Power Supply Modules Overview	81
Installation Guidelines	86
Installing or Replacing an AC Power Supply	87
Installing a DC Power Supply	89
Equipment That You Need	89
Grounding the Switch	90
Installing the DC Power Supply in the Switch	92
Wiring the DC Input Power Source	93
Finding the Power Supply Module Serial Number	94

CHAPTER 6
Installing a Fan Module 97

Fan Modules Overview	97
Installation Guidelines	98
Installing a Fan Module	98
Finding the Fan Module Serial Number	99

CHAPTER 7
Installing a USB 3.0 SSD 101

USB 3.0 SSD Overview	101
Installing an SSD Module on C9300, C9300X and C9300L Switches	102
Installing an SSD Module on C9300LM Switches	104

CHAPTER 8

Configuring the Switch 107

- Configuring the Switch Using the Web User Interface 107
- Configuring the Switch Using the CLI 107
 - Accessing the CLI Through the Console Port 107
 - Connecting the RJ45 Console Port 107
 - Connecting the USB Console Port 108
 - Installing the Microsoft Windows USB Device Driver 109
 - Installing the Cisco Microsoft Windows USB Driver 109
 - Installing the Silicon Labs Windows USB Device Driver 110
 - Uninstalling the Cisco Microsoft Windows USB Driver 110
 - Uninstalling the Cisco Microsoft Windows USB Driver 110

APPENDIX A

Technical Specifications 111

- Environmental and Physical Specifications 111
- Specifications for the Power Supplies, Switches, and Fan 116
- AC Power Cord Specifications 118

APPENDIX B

Connector and Cable Specifications 121

- Connector Specifications 121
 - 10/100/1000 Ports (Including PoE) 121
 - Module Connectors 121
 - MPO-12 Connectors 122
- Console Port 123
- Cables and Adapters 123
 - StackWise Accessories 123
 - Transceiver Module Network Cables 125
 - Cable Pinouts 126
 - Console Port Adapter Pinouts 127

THE SPECIFICATIONS AND INFORMATION REGARDING THE PRODUCTS IN THIS MANUAL ARE SUBJECT TO CHANGE WITHOUT NOTICE. ALL STATEMENTS, INFORMATION, AND RECOMMENDATIONS IN THIS MANUAL ARE BELIEVED TO BE ACCURATE BUT ARE PRESENTED WITHOUT WARRANTY OF ANY KIND, EXPRESS OR IMPLIED. USERS MUST TAKE FULL RESPONSIBILITY FOR THEIR APPLICATION OF ANY PRODUCTS.

THE SOFTWARE LICENSE AND LIMITED WARRANTY FOR THE ACCOMPANYING PRODUCT ARE SET FORTH IN THE INFORMATION PACKET THAT SHIPPED WITH THE PRODUCT AND ARE INCORPORATED HEREIN BY THIS REFERENCE. IF YOU ARE UNABLE TO LOCATE THE SOFTWARE LICENSE OR LIMITED WARRANTY, CONTACT YOUR CISCO REPRESENTATIVE FOR A COPY.

The following information is for FCC compliance of Class A devices: This equipment has been tested and found to comply with the limits for a Class A digital device, pursuant to part 15 of the FCC rules. These limits are designed to provide reasonable protection against harmful interference when the equipment is operated in a commercial environment. This equipment generates, uses, and can radiate radio-frequency energy and, if not installed and used in accordance with the instruction manual, may cause harmful interference to radio communications. Operation of this equipment in a residential area is likely to cause harmful interference, in which case users will be required to correct the interference at their own expense.

The following information is for FCC compliance of Class B devices: This equipment has been tested and found to comply with the limits for a Class B digital device, pursuant to part 15 of the FCC rules. These limits are designed to provide reasonable protection against harmful interference in a residential installation. This equipment generates, uses and can radiate radio frequency energy and, if not installed and used in accordance with the instructions, may cause harmful interference to radio communications. However, there is no guarantee that interference will not occur in a particular installation. If the equipment causes interference to radio or television reception, which can be determined by turning the equipment off and on, users are encouraged to try to correct the interference by using one or more of the following measures:

- Reorient or relocate the receiving antenna.
- Increase the separation between the equipment and receiver.
- Connect the equipment into an outlet on a circuit different from that to which the receiver is connected.
- Consult the dealer or an experienced radio/TV technician for help.

Modifications to this product not authorized by Cisco could void the FCC approval and negate your authority to operate the product.

The Cisco implementation of TCP header compression is an adaptation of a program developed by the University of California, Berkeley (UCB) as part of UCB's public domain version of the UNIX operating system. All rights reserved. Copyright © 1981, Regents of the University of California.

NOTWITHSTANDING ANY OTHER WARRANTY HEREIN, ALL DOCUMENT FILES AND SOFTWARE OF THESE SUPPLIERS ARE PROVIDED "AS IS" WITH ALL FAULTS. CISCO AND THE ABOVE-NAMED SUPPLIERS DISCLAIM ALL WARRANTIES, EXPRESSED OR IMPLIED, INCLUDING, WITHOUT LIMITATION, THOSE OF MERCHANTABILITY, FITNESS FOR A PARTICULAR PURPOSE AND NONINFRINGEMENT OR ARISING FROM A COURSE OF DEALING, USAGE, OR TRADE PRACTICE.

IN NO EVENT SHALL CISCO OR ITS SUPPLIERS BE LIABLE FOR ANY INDIRECT, SPECIAL, CONSEQUENTIAL, OR INCIDENTAL DAMAGES, INCLUDING, WITHOUT LIMITATION, LOST PROFITS OR LOSS OR DAMAGE TO DATA ARISING OUT OF THE USE OR INABILITY TO USE THIS MANUAL, EVEN IF CISCO OR ITS SUPPLIERS HAVE BEEN ADVISED OF THE POSSIBILITY OF SUCH DAMAGES.

Any Internet Protocol (IP) addresses and phone numbers used in this document are not intended to be actual addresses and phone numbers. Any examples, command display output, network topology diagrams, and other figures included in the document are shown for illustrative purposes only. Any use of actual IP addresses or phone numbers in illustrative content is unintentional and coincidental.

All printed copies and duplicate soft copies of this document are considered uncontrolled. See the current online version for the latest version.

Cisco has more than 200 offices worldwide. Addresses and phone numbers are listed on the Cisco website at www.cisco.com/go/offices.

Cisco and the Cisco logo are trademarks or registered trademarks of Cisco and/or its affiliates in the U.S. and other countries. To view a list of Cisco trademarks, go to this URL: <https://www.cisco.com/c/en/us/about/legal/trademarks.html>. Third-party trademarks mentioned are the property of their respective owners. The use of the word partner does not imply a partnership relationship between Cisco and any other company. (1721R)

© 2017–2023 Cisco Systems, Inc. All rights reserved.



Preface

This preface describes the conventions of this document and information on how to obtain other documentation. It also provides information on what's new in Cisco product documentation.

- [Document Conventions](#) , on page ix
- [Related Documentation](#), on page xi
- [Obtaining Documentation and Submitting a Service Request](#), on page xi

Document Conventions

This document uses the following conventions:

Convention	Description
^ or Ctrl	Both the ^ symbol and Ctrl represent the Control (Ctrl) key on a keyboard. For example, the key combination ^D or Ctrl-D means that you hold down the Control key while you press the D key. (Keys are indicated in capital letters but are not case sensitive.)
bold font	Commands and keywords and user-entered text appear in bold font .
<i>Italic font</i>	Document titles, new or emphasized terms, and arguments for which you supply values are in <i>italic font</i> .
Courier font	Terminal sessions and information the system displays appear in <code>courier font</code> .
Bold Courier font	Bold Courier font indicates text that the user must enter.
[x]	Elements in square brackets are optional.
...	An ellipsis (three consecutive nonbolded periods without spaces) after a syntax element indicates that the element can be repeated.
	A vertical line, called a pipe, indicates a choice within a set of keywords or arguments.
[x y]	Optional alternative keywords are grouped in brackets and separated by vertical bars.

Convention	Description
{x y}	Required alternative keywords are grouped in braces and separated by vertical bars.
[x {y z}]	Nested set of square brackets or braces indicate optional or required choices within optional or required elements. Braces and a vertical bar within square brackets indicate a required choice within an optional element.
string	A nonquoted set of characters. Do not use quotation marks around the string or the string will include the quotation marks.
<>	Nonprinting characters such as passwords are in angle brackets.
[]	Default responses to system prompts are in square brackets.
!, #	An exclamation point (!) or a pound sign (#) at the beginning of a line of code indicates a comment line.

Reader Alert Conventions

This document may use the following conventions for reader alerts:



Note Means *reader take note*. Notes contain helpful suggestions or references to material not covered in the manual.



Tip Means *the following information will help you solve a problem*.



Caution Means *reader be careful*. In this situation, you might do something that could result in equipment damage or loss of data.



Timesaver Means *the described action saves time*. You can save time by performing the action described in the paragraph.



Warning IMPORTANT SAFETY INSTRUCTIONS

Before you work on any equipment, be aware of the hazards involved with electrical circuitry and be familiar with standard practices for preventing accidents. Read the installation instructions before using, installing, or connecting the system to the power source. Use the statement number provided at the end of each warning statement to locate its translation in the translated safety warnings for this device. Statement 1071

SAVE THESE INSTRUCTIONS

Related Documentation



Note Before installing or upgrading the switch, refer to the switch Release Notes.

- Cisco Catalyst 9300 Series Switches documentation, located at: <http://www.cisco.com/go/c9300>
- Cisco Transceiver Modules documentation, including compatibility matrixes, located at:
http://www.cisco.com/en/US/products/hw/modules/ps5455/tsd_products_support_series_home.html
- Cisco Validated Designs documents, located at:
<http://www.cisco.com/go/designzone>

Obtaining Documentation and Submitting a Service Request

For information on obtaining documentation, submitting a service request, and gathering additional information, see the monthly *What's New in Cisco Product Documentation*, which also lists all new and revised Cisco technical documentation, at:

<http://www.cisco.com/c/en/us/td/docs/general/whatsnew/whatsnew.html>

Subscribe to the *What's New in Cisco Product Documentation* as a Really Simple Syndication (RSS) feed and set content to be delivered directly to your desktop using a reader application. The RSS feeds are a free service and Cisco currently supports RSS version 2.0.



CHAPTER 1

Product Overview

Cisco Catalyst 9300 Series Switches family is the stackable enterprise switching platform built for Security, IoT, Mobility, and Cloud. It has the most flexible uplink architecture with support for 1 GE, 10 GE, 25 GE, 40 GE and 100 GE.

Cisco Catalyst 9300 Series Switches provide support for the following features:

- 24 and 48 10/100/1000 M downlink ports with data, PoE+, Cisco UPOE and Cisco UPOE+ support
- 24 and 48 100 Mbps/1/2.5/5/10 Gbps ports with Cisco UPOE support
- Fixed 1G or 10G uplinks or modular 1 GE, 10 GE, 25 GE, 40 GE, 100 GE and Multigigabit uplinks
- Advanced security capabilities like Encrypted Traffic Analytics (ETA), AES-256 MACSEC encryption, and TrustWorthy systems
- High speed back-panel data stacking solution with StackWise-320 (C9300L and C9300LM), StackWise-480 (C9300), and StackWise-1T (C9300X)
- Intelligent Power Management with StackPower technology that provides power stacking among members for power redundancy
- IoT integration and policy-based automation from the edge to the cloud with SD-Access solution
- RJ-45 and USB Mini-Type B console ports
- USB Type A and USB Type C ports that support USB 3.0 and source 900 mA at 5 V
- External USB 3.0 SSD pluggable storage support
- [Switch Models, on page 2](#)
- [Front Panel Components, on page 5](#)
- [Rear Panel, on page 21](#)
- [Network Configurations, on page 30](#)

Switch Models

Table 1: Cisco Catalyst 9300 Series Switches Models and Descriptions

Switch Model	Description
C9300-24H	Stackable 24 10/100/1000 Mbps UPOE+ ports; PoE budget of 830 W with 1100 WAC power supply; supports StackWise-480 and StackPower.
C9300-24P	Stackable 24 10/100/1000 Mbps PoE+ ports; PoE budget of 445 W with 715 WAC power supply; supports StackWise-480 and StackPower.
C9300-24S	Stackable 24 10/100/1000 Mbps SFP ports; two power supply slots with 715 WAC power supply installed by default; supports StackWise-480 and StackPower.
C9300-24T	Stackable 24 10/100/1000 Mbps Ethernet ports; 350 WAC power supply; supports StackWise-480 and StackPower.
C9300-24U	Stackable 24 10/100/1000 Mbps UPOE ports; PoE budget of 830 W with 1100 WAC power supply; supports StackWise-480 and StackPower.
C9300-24UB	Stackable 24 10/100/1000 Mbps UPOE ports that provide deep buffers and higher scale; PoE budget of 830 W with 1100 WAC power supply; supports StackWise-480 and StackPower.
C9300-24UX	Stackable 24 Multigigabit Ethernet (100 Mbps or 1/2.5/5/10 Gbps) UPOE ports; PoE budget of 560 W with 1100 WAC power supply; supports StackWise-480 and StackPower.
C9300-24UXB	Stackable 24 Multigigabit Ethernet (100 Mbps or 1/2.5/5/10 Gbps) UPOE ports that provide deep buffers and higher scale; PoE budget of 560 W with 1100 WAC power supply; supports StackWise-480 and StackPower.
C9300-48H	Stackable 48 10/100/1000 Mbps UPOE+ ports; PoE budget of 822 W with 1100 WAC power supply; supports StackWise-480 and StackPower.
C9300-48P	Stackable 48 10/100/1000 Mbps PoE+ ports; PoE budget of 437 W with 715 WAC power supply; supports StackWise-480 and StackPower.
C9300-48S	Stackable 48 10/100/1000 Mbps SFP ports; two power supply slots with 715 WAC power supply installed by default; supports StackWise-480 and StackPower.
C9300-48T	Stackable 48 10/100/1000 Mbps Ethernet ports; 350 WAC power supply; supports StackWise-480 and StackPower.
C9300-48U	Stackable 48 10/100/1000 Mbps UPOE ports; PoE budget of 822 W with 1100 WAC power supply; supports StackWise-480 and StackPower.
C9300-48UB	Stackable 48 10/100/1000 Mbps UPOE ports that provide deep buffers and higher scale; PoE budget of 822 W with 1100 WAC power supply; supports StackWise-480 and StackPower.

Switch Model	Description
C9300-48UN	Stackable 48 (12 Multigigabit Ethernet and 36 2.5 Gbps) UPOE ports; PoE budget of 490 W with 1100 WAC power supply; supports StackWise-480 and StackPower.
C9300-48UXM	Stackable 48 Multigigabit Ethernet (100 Mbps or 1/2.5/5 Gbps) UPOE ports; PoE budget of 610 W with 1100 WAC power supply; supports StackWise-480 and StackPower.

Table 2: Cisco Catalyst 9300L Series Switches Models and Descriptions

Switch Model	Description
C9300L-24T-4G	Stackable 24 10/100/1000 Mbps Ethernet ports; 4x1 GE SFP fixed uplink ports; 350 WAC power supply; supports StackWise-320.
C9300L-24P-4G	Stackable 24 10/100/1000 Mbps PoE+ ports; 4x1 GE SFP fixed uplink ports; PoE budget of 505 W with 715 WAC power supply; supports StackWise-320.
C9300L-24T-4X	Stackable 24 10/100/1000 Mbps Ethernet ports; 4x10 GE SFP+ fixed uplink ports; 350 WAC power supply; supports StackWise-320.
C9300L-24P-4X	Stackable 24 10/100/1000 Mbps PoE+ ports; 4x10 GE SFP+ fixed uplink ports; PoE budget of 505 W with 715 WAC power supply; supports StackWise-320.
C9300L-48T-4G	Stackable 48 10/100/1000 Mbps Ethernet ports; 4x1 GE SFP fixed uplink ports; 350 WAC power supply; supports StackWise-320.
C9300L-48P-4G	Stackable 48 10/100/1000 Mbps PoE+ ports; 4x1G SFP fixed uplink ports; PoE budget of 505 W with 715 WAC power supply; supports StackWise-320.
C9300L-48T-4X	Stackable 48 10/100/1000 Mbps Ethernet ports; 4x10 GE SFP+ fixed uplink ports; 350 WAC power supply; supports StackWise-320.
C9300L-48P-4X	Stackable 48 10/100/1000 Mbps PoE+ ports; 4x10 GE SFP+ fixed uplink ports; PoE budget of 505 W with 715 WAC power supply; supports StackWise-320.
C9300L-48PF-4G	Stackable 48 10/100/1000 Mbps PoE+ ports; 4x1 GE SFP+ fixed uplink ports; PoE budget of 890 W with 1100 WAC power supply; supports StackWise-320.
C9300L-48PF-4X	Stackable 48 10/100/1000 Mbps PoE+ ports; 4x10 GE SFP+ fixed uplink ports; PoE budget of 890 W with 1100 WAC power supply; supports StackWise-320.
C9300L-24UXG-4X	Stackable 16 10/100/1000 Mbps and 8 Multigigabit Ethernet (100 Mbps or 1/2.5/5/10 Gbps) UPOE ports; 4x10 GE SFP+ fixed uplink ports; PoE budget of 880 W with 1100 WAC power supply; supports StackWise-320.
C9300L-24UXG-2Q	Stackable 16 10/100/1000 Mbps and 8 Multigigabit Ethernet (100 Mbps or 1/2.5/5/10 Gbps) UPOE ports; 2x40 GE QSFP+ fixed uplink ports; PoE budget of 722 W with 1100 WAC power supply; supports StackWise-320.
C9300L-48UXG-4X	Stackable 36 10/100/1000 Mbps and 12 Multigigabit Ethernet (100 Mbps or 1/2.5/5/10 Gbps) UPOE ports; 4x10 GE SFP+ fixed uplink ports; PoE budget of 675 W with 1100 WAC power supply; supports StackWise-320.

Switch Model	Description
C9300L-48UXG-2Q	Stackable 36 10/100/1000 Mbps and 12 Multigigabit Ethernet (100 Mbps or 1/2.5/5/10 Gbps) UPOE ports; 2x40 GE QSFP+ fixed uplink ports; PoE budget of 675 W with 1100 WAC power supply; supports StackWise-320.

Table 3: Cisco Catalyst 9300LM Series Switches Models and Descriptions

Switch Model	Description
C9300LM-48T-4Y	Stackable 48 x 10/100/1000 M Ethernet ports; 4 x 25 GE SFP28 fixed uplink ports; 600 WAC power supply and fixed fans; supports StackWise-320.
C9300LM-24U-4Y	Stackable 24 x 10/100/1000 M UPOE ports; 4 x 25 GE SFP28 fixed uplink ports; PoE budget of 420 W with a single default 600 WAC power supply; supports StackWise-320.
C9300LM-48U-4Y	Stackable 48 x 10/100/1000 M UPOE ports; 4 x 25 GE SFP28 fixed uplink ports; PoE budget of 790 W with a single default 1000 WAC power supply; supports StackWise-320.
C9300LM-48UX-4Y	Stackable 40 x 10/100/1000 M and 8 Multigigabit Ethernet (100M/1000M/2.5GE/5GE/10GE) UPOE ports; 4 x 25 GE SFP28 fixed uplink ports; PoE budget of 790 W with a single default 1000 WAC power supply; supports StackWise-320.

Table 4: Cisco Catalyst 9300X Series Switches Models and Descriptions

Switch Model	Description
C9300X-12Y	Stackable 12 1/10/25 GE SFP28 downlink ports; 715 WAC power supply; supports StackPower+, StackWise-1T and C9300X-NM network modules.
C9300X-24Y	Stackable 24 1/10/25 GE SFP28 downlink ports; 715 WAC power supply; supports StackPower+, StackWise-1 and C9300X-NM network modules.
C9300X-48HX	Stackable 48 Multigigabit Ethernet (100 Mbps or 1/2.5/5/10 Gbps) UPOE+ ports; PoE budget of 590 W with 1100 WAC power supply; supports StackPower+, StackWise-1T and C9300X-NM network modules.
C9300X-48TX	Stackable 48 Multigigabit Ethernet (100 Mbps or 1/2.5/5/10 Gbps) ports; 715 WAC power supply; supports StackPower+, StackWise-1T and C9300X-NM network modules.
C9300X-24HX	Stackable 24 Multigigabit Ethernet (100 Mbps or 1/2.5/5/10 Gbps) UPOE+ ports; PoE budget of 735W with 1100WAC power supply; supports StackPower+, StackWise-1T and C9300X-NM network modules.
C9300X-48HXN	Stackable 40 x 100/1000 M or 2.5/5 GE Multigigabit Ethernet and 8 x 100/1000 M or 2.5/5/10 GE Multigigabit Ethernet UPOE+ ports; PoE budget of 690W with 1100WAC power supply; supports StackPower+, StackWise-1T and C9300X-NM network modules.

Front Panel Components

Front Panel Components of a Cisco Catalyst 9300 Series Switch

- 12, 24 or 48 downlink ports of one of these types:
 - 10 M/100 M/1000 M
 - 1 GE/10 GE/25 GE SFP28
 - 10 M/100 M/1000 M PoE+
 - 10 M/100 M/1000 M Cisco UPOE/UPOE+
 - Multigigabit Ethernet 100 M/1 GE/2.5 GE/5 GE/10 GE Cisco UPOE
- Uplink network module slots
- USB Type A connector
- USB mini-Type B (console) port
- LEDs
- Mode button
- Beacon LED (UID button)

All the switch models have similar components. See the following illustration for example.



Note The Catalyst 9300 switches might have slight cosmetic differences on the bezels.

Figure 1: C9300-48P Switch Front Panel

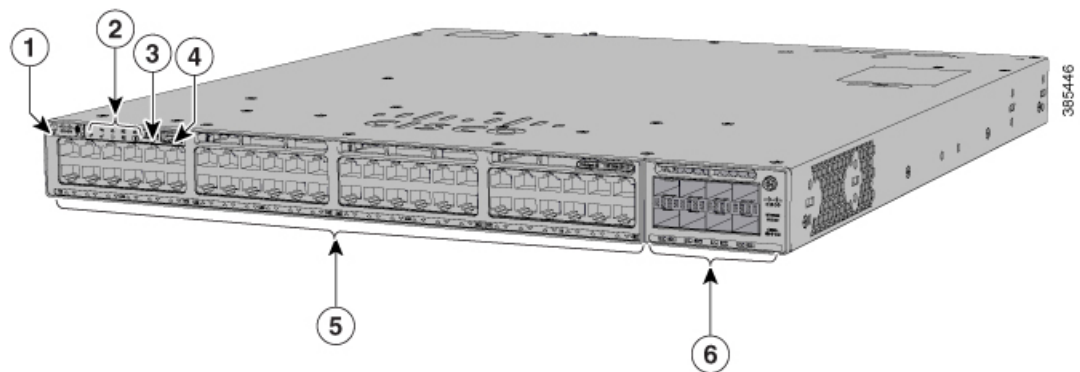

1	Beacon LED (UID button)	4	USB Type A storage port
2	Status LEDs	5	10 M/100 M/1000 M PoE+ ports
3	USB mini-Type B (console) port	6	Network module slots

Figure 2: C9300-48UXM Switch Front Panel

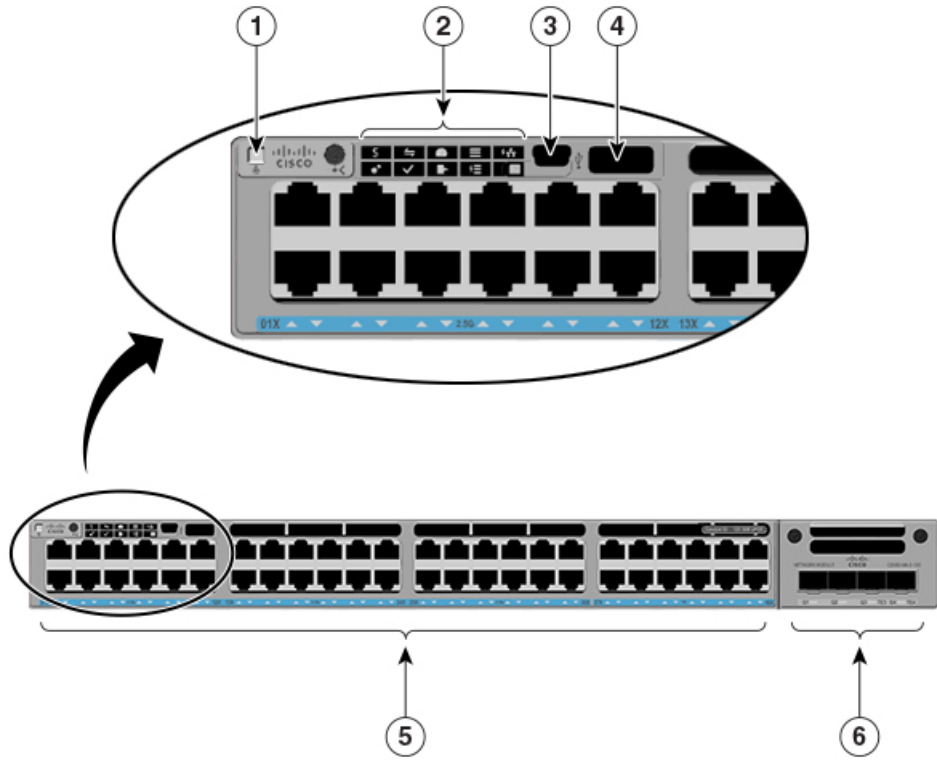

355373

1	Beacon LED (UID button)	4	USB Type A storage port
2	Status LEDs	5	Ports 1-36 of 100 M/1000 M/2.5 GE and ports 37-48 of 100 M/1000 M/2.5 GE/5 GE/10 GE
3	USB mini-Type B (console) port	6	Network module slots

Figure 3: Front panel components of C9300-48S

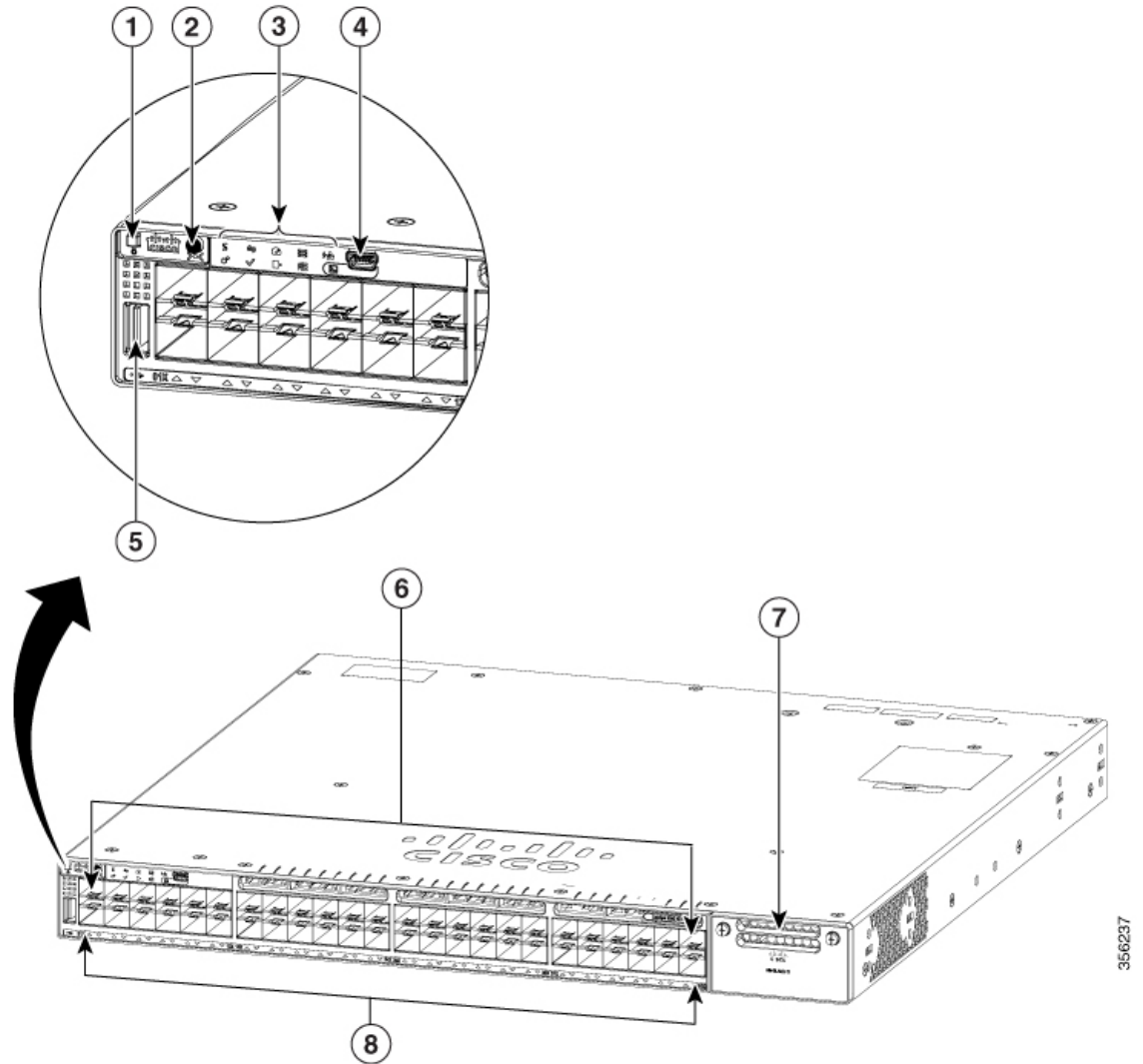

1	Beacon LED (UID button)	5	USB Type A storage port
2	Mode button	6	10 M/100 M/1000 M SFP ports
3	Status LEDs	7	Uplink network module slots
4	USB mini-Type B (console) port	8	Port LEDs

Front panel components of a Cisco Catalyst 9300L Series Switch

- 12, 24 or 48 downlink ports of one of these types:
 - 10 M/100 M/1000 M
 - 1 GE/10 GE/25 GE SFP28

- 10 M/100 M/1000 M PoE+
- 10 M/100 M/1000 M Cisco UPOE/UPOE+
- Multigigabit Ethernet 100 M/1 GE/2.5 GE/5 GE/10 GE Cisco UPOE

- SFP/SFP+/QSFP+ fixed uplink ports
- USB Type A connector
- USB mini-Type B (console) port
- LEDs
- Mode button
- Beacon LED (UID button)

Figure 4: C9300L-48P-4X Switch Front Panel

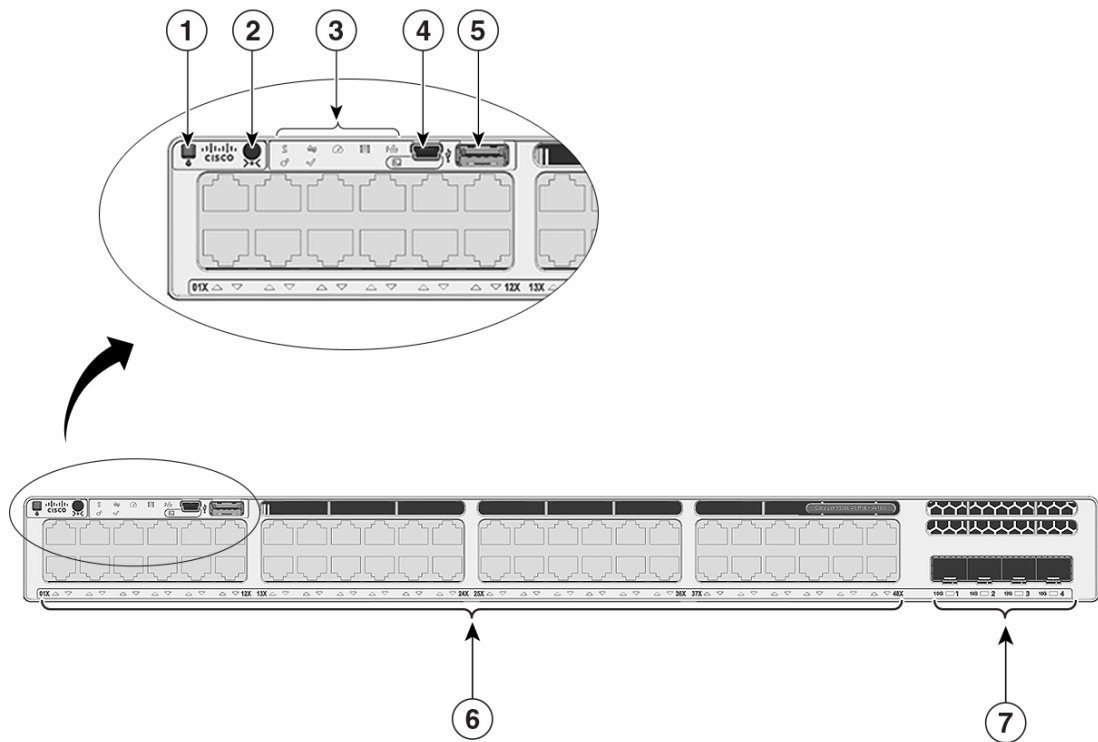

1	Beacon LED (UID button)	5	USB Type A storage port
2	Mode button	6	10 M/100 M/1000 M PoE+ ports
3	Status LEDs	7	Fixed uplink ports
4	USB mini-Type B (console) port	-	-

Front Panel Components of a Cisco Catalyst 9300LM Series Switch

- 24 or 48 downlink ports of one of these types:
 - 10 M/100 M/1000 M
 - 10 M/100 M/1000 M Cisco UPOE
 - Multigigabit Ethernet 100 M/1 GE/2.5 GE/5 GE/10 GE Cisco UPOE
- 1 GE/10 GE/25 GE fixed uplink ports
- USB mini-Type B (console) port
- USB 3.0 Type A connector
- USB Type C connector
- LEDs
- Mode button
- Beacon LED (UID button)

Figure 5: C9300LM-48UX-4Y Switch Front Panel

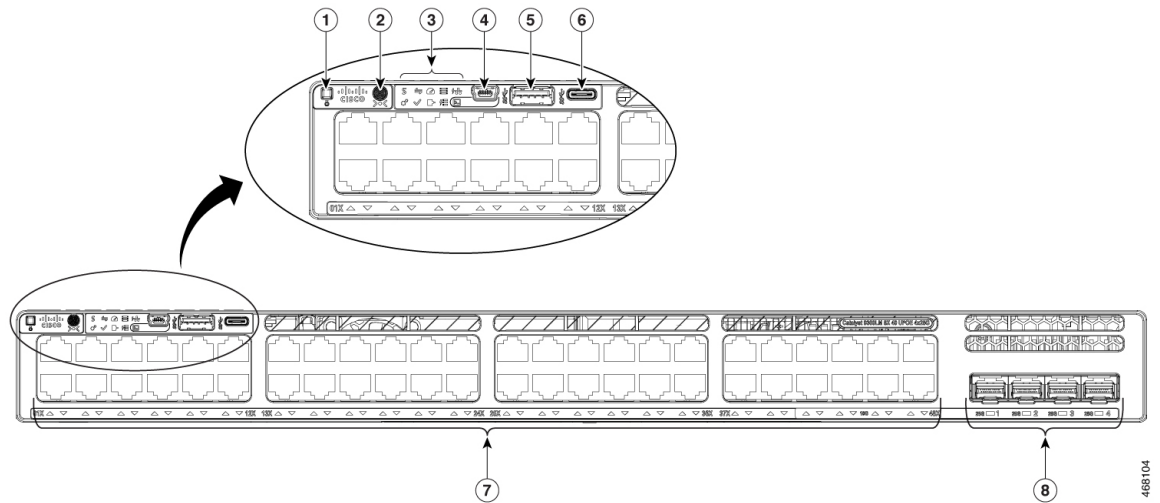

1	Beacon LED (UID button)	5	USB Type A storage port
2	Mode button	6	USB Type C port
3	Status LEDs	7	10/100/1000 M UPOE ports
4	USB mini-Type B (console) port	8	Fixed uplink ports

Front panel components of a Cisco Catalyst 9300X Series switch

- 12, 24 or 48 downlink ports of one of these types:
 - 10 M/100 M/1000 M

- 1 GE/10 GE/25 GE SFP28
- 10 M/100 M/1000 M PoE+
- 10 M/100 M/1000 M Cisco UPOE/UPOE+
- Multigigabit Ethernet 100 M/1 GE/2.5 GE/5 GE/10 GE Cisco UPOE
- Uplink network module slots
- USB Type A connector
- USB Type C connector
- USB mini-Type B (console) port
- LEDs
- Mode button
- Beacon LED (UID button)

Figure 6: C9300X-24Y Switch Front Panel

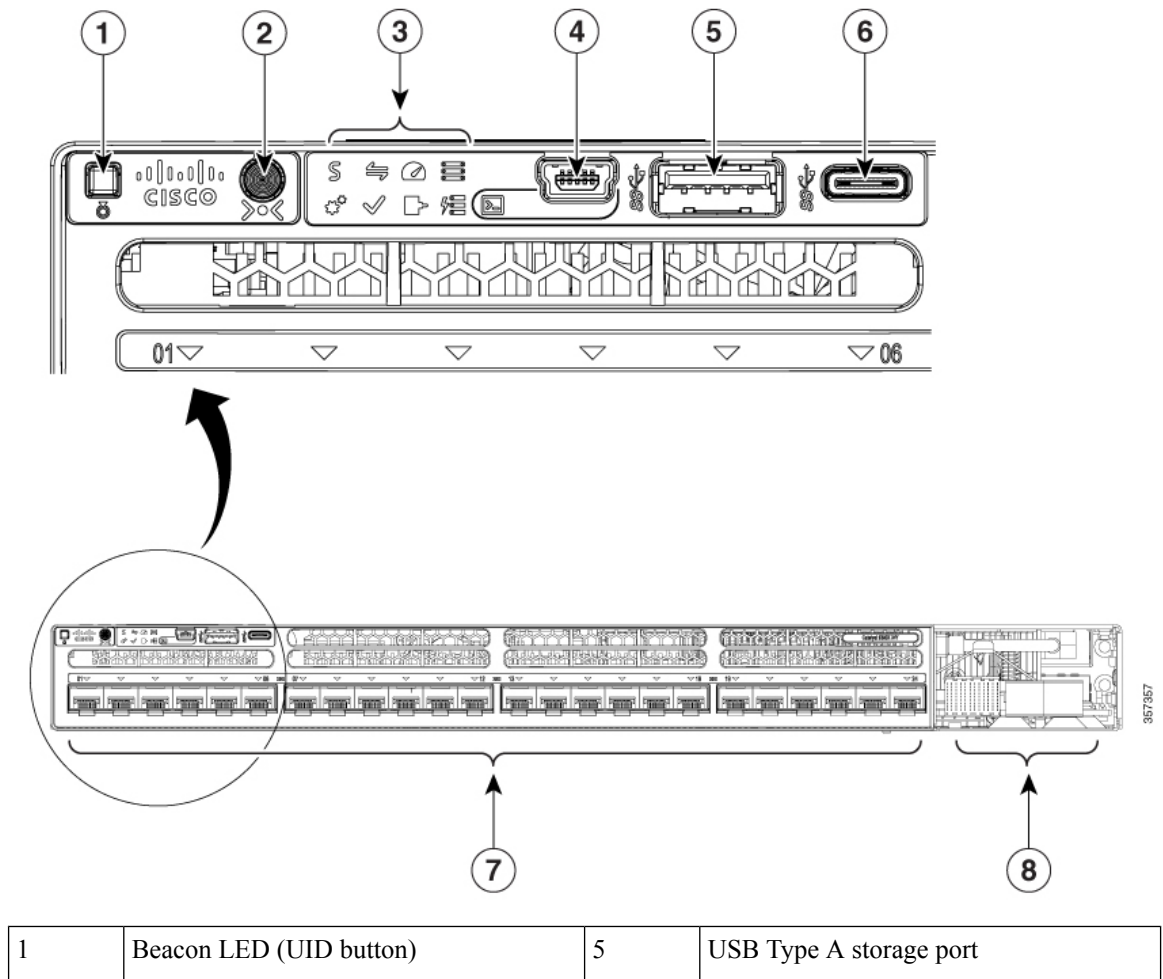

2	Mode button	6	USB Type C port
3	Status LEDs	7	1 GE/25 GE/25 GE SFP28 ports
4	USB mini-Type B (console) port	8	Uplink network module slots

10/100/1000 Ports

The 10/100/1000 ports use RJ-45 connectors with Ethernet pinouts. The maximum cable length is 328 feet (100 meters). The 100BASE-TX and 1000BASE-T traffic requires twisted pair (UTP) cable of Category 5 or higher. The 10BASE-T traffic can use Category 3 cable or higher.

PoE, PoE+, Cisco UPOE and Cisco UPOE+ Ports

The PoE+ and Cisco Universal Power Over Ethernet (Cisco UPOE and Cisco UPOE+) ports use the same connectors as described in [10/100/1000/Multigigabit Ethernet Port Connections, on page 65](#). They provide:

- PoE+ ports: Support for IEEE 802.3af-compliant powered devices (up to 15.4 W PoE per port) and support for IEEE 802.3at-compliant powered devices (up to 30 W PoE+ per port).
- Cisco UPOE ports: Support for Type 1 (IEEE 802.3af), Type 2 (IEEE 802.3at), Type 3 (IEEE 802.3bt), and Cisco UPOE powered devices delivering up to 60 W PoE per port. The maximum total PoE power in a 1RU switch is 1800 W.
- Cisco UPOE+ ports: Support for Type 1 (IEEE 802.3af), Type 2 (IEEE 802.3at), Type 3 (IEEE 802.3bt), Type 4 (IEEE 802.3bt), and Cisco UPOE powered devices delivering up to 90 W per port.
- Support for pre-standard Cisco powered devices.
- Configuration for StackPower. When the switch internal power supply module(s) cannot support the total load, StackPower configurations allow the switch to leverage power available from other switches.
- Configurable support for Cisco intelligent power management, including enhanced power negotiation, power reservation, and per-port power policing.

See the [Power Supply Modules, on page 25](#) for the power supply matrix that defines the available PoE, PoE+ and Cisco UPOE/UPOE+ power per port. The output of the PoE+ or Cisco UPOE/UPOE+ circuit has been evaluated as a Limited Power Source (LPS) per IEC 60950-1.

Multigigabit Ethernet Ports

The Multigigabit (mGig) Ethernet ports can be configured to auto-negotiate multiple speeds on switch ports. The ports support 100 Mbps, 1 Gbps, 2.5 Gbps, and 5 Gbps speeds on Category 5e (Cat5e) cables, and up to 10 Gbps over Category 6 (Cat6) and Category 6A (Cat6A) cables up to a maximum of 100 m. 10Gbps over Cat6 cable is limited for distances up to 55 m. For 10GBASE-T, Cat6a can support up to 100 m when transmitting 10Gbps. Due to the extra bandwidth requirements from the cable, additional limitations exist for best performance. These limitations include, but are not limited to cable reach, cable bundling parameters (tightness, frequency, number of cables, speed with respect to each cable) and cable termination quality.

The 802.3 channel requirements for interoperability typically limit the cable reach to 100 m, but other factors can shorten this reach. In addition, for both Cisco UPOE and Cisco UPOE+ and data integrity, the 100 m total should not include more than 10 m total stranded or patch cable. Therefore, it is assumed that a 100 m link

includes a maximum of two 5 m patch cables of the appropriate category, and 90 m of plenum or riser (i.e. solid copper core) cables. Ensure that you follow the TIA guidance on cable dressing.

It is recommended to test the complete link using an appropriate cable tester for 10 Gbps as well as 5 Gbps links. However, even if the link passes cable testing, it is still prone to occasional errors due to aggressors in the bundle, and physical disturbances of the cables. As an example of bundling limitations, for 5 Gbps with cat5e cable, only a total 45 m bundled length is supported; the remaining 55 m should be unbundled. For bundling, follow [Cisco Guidelines and Best Practices for the Installation and Maintenance of Data Networking Equipment](#) which recommends the use of Velcro ties every 1 to 2 m for bundled sections.

If you are upgrading the network gear but reusing the existing cable plant, note that at speeds above 2.5 Gbps traditional Cat5e channel specifications do not support full 100 m reach. To ensure 5 Gbps link speeds, we recommend using Cat6a cabling. For more information, see the Whitepaper from NBASE-T alliance, which has now merged with Ethernet Alliance, archived at <https://archive.nbaset.ethernetalliance.org/library/white-paper-2/>.



Note Multigigabit ports do not support half duplex mode. Use full duplex mode.

Management Ports

The management ports connect the switch to a PC running Microsoft Windows or to a terminal server.

- Ethernet management port. See [Ethernet Management Port, on page 30](#).
- RJ-45 console port (EIA/TIA-232). See [RJ-45 Console Port, on page 30](#).
- USB mini-Type B console port (5-pin connector).

The 10/100/1000 Ethernet management port connection uses a standard RJ-45 crossover or straight-through cable. The RJ-45 console port connection uses the supplied RJ-45-to-DB-9 female cable. The USB console port connection uses a USB Type A to 5-pin mini-Type B cable. The USB console interface speeds are the same as the RJ-45 console interface speeds.

If you use the USB mini-Type B console port, the Cisco Windows USB device driver must be installed on any PC connected to the console port (for operation with Microsoft Windows). Mac OS X or Linux do not require special drivers.

The 4-pin mini-Type B connector resembles the 5-pin mini-Type B connectors. They are not compatible. Use only the 5-pin mini-Type B.

Figure 7: USB Mini-Type B Port

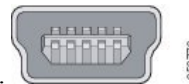

This illustration shows a 5-pin mini-Type B USB port.

With the Cisco Windows USB device driver, you can connect and disconnect the USB cable from the console port without affecting Windows HyperTerminal operations.

The console output always goes to both the RJ-45 and the USB console connectors, but the console input is active on only one of the console connectors at any one time. The USB console takes precedence over the RJ-45 console. When a cable is connected into the USB console port, the RJ-45 console port becomes inactive. Conversely, when the USB cable is disconnected from the USB console port, the RJ-45 port becomes active.

You can use the command-line interface (CLI) to configure an inactivity timeout which reactivates the RJ-45 console if the USB console has been activated and no input activity has occurred on the USB console for a specified time.

After the USB console deactivates due to inactivity, you cannot use the CLI to reactivate it. Disconnect and reconnect the USB cable to reactivate the USB console. For information on using the CLI to configure the USB console interface, see the Software Configuration Guide.

USB Type A and Type C Ports

The USB Type A and Type C ports provide access to external USB flash devices (also known as thumb drives or USB keys).

The USB Type A port supports Cisco USB flash drives with capacities from 128 MB to 8 GB (USB devices with port densities of 128 MB, 256 MB, 1 GB, 4 GB, and 8 GB are supported). Whereas, USB Type C port provides support for flash drives with capacities from 128 MB to 256 GB.

In a switch stack, you can upgrade all the switches in the stack with a USB key inserted in any switch member within the stack. Cisco IOS software enables the flash drive with standard file system access such as read, write, erase, and copy, as well as the ability to format the flash device with a FAT file system.

These ports enable you to automatically upgrade the internal flash with the USB drive's configuration and image for emergency switch recovery using USB auto-upgrade. This feature checks the internal flash for a bootable image and configuration and if either image or the configuration is not available, then the USB drive is checked for boot images and configuration. If the boot image and configuration are available, these are copied to the flash for a reboot.

Uplink Ports

The Cisco Catalyst 9300 Series switches support both fixed and modular uplinks. The C9300 and C9300X switch models support optional hot-swappable network modules that provide uplink ports to connect to other devices. The C9300L switches provide fixed uplink ports that support 10 GE and 1 GE SFP/SFP+ modules.

The switch generates logs when you insert or remove a network module with SFP/SFP+/SFP28 ports.

The following table lists the optional Cisco Catalyst 9300 uplink network modules. In addition, Cisco Catalyst 9300 Series switches also support 3850 uplink network modules.

Table 5: Network Modules

Network Module ¹	Description
C9300-NM-4G	This module has four 1 GE SFP module slots. Any combination of standard SFP modules are supported. SFP+ modules are not supported. If you insert an SFP+ module in the 1 GE network module, the SFP+ module does not operate, and the switch logs an error message.
C9300-NM-4M	This module has four Multigigabit (mGig) interfaces.
C9300-NM-2Q	This module has two 40 GE slots with a QSFP+ connector in each slot.

Network Module ¹	Description
C9300-NM-8X	This module has eight 10 GE slots with an SFP+ port in each slot. Each port supports a 1 GE or 10 GE connection. Any combination of SFP and SFP+ modules are supported.
C9300-NM-2Y	This module has two 25 GE SFP28 module slots. Any combination of SFP, SFP+ and SFP28 modules are supported.
C9300-NM-BLANK	Insert this blank module when the switch has no uplink ports (this is required for sufficient air flow).
C9300X Network Modules¹	
Note Note that C9300X network modules are supported only on C9300X switches.	
C9300X-NM-2C	This module has two 40 GE/100 GE slots with a QSFP+ connector in each slot.
C9300X-NM-4C	This module has four 40 GE/100 GE slots with a QSFP+ connector in each slot. This module is supported only on C9300X-24Y.
C9300X-NM-8M	This module has eight Multigigabit (mGig) module slots.
C9300X-NM-8Y	This module has eight 25 GE/10 GE/1 GE slots with an SFP28 port in each slot.
C9300X-NM-BLANK	Insert this blank module when the switch has no uplink ports (this is required for sufficient air flow).



Note 1. All network modules are hot-swappable.

For information about the network modules, see the [Installing a Network Module in the Switch, on page 68](#).
For cable specifications, see [Cables and Adapters, on page 123](#).

LEDs

You can use the switch LEDs to monitor switch activity and its performance.

Figure 8: Switch Front Panel LEDs

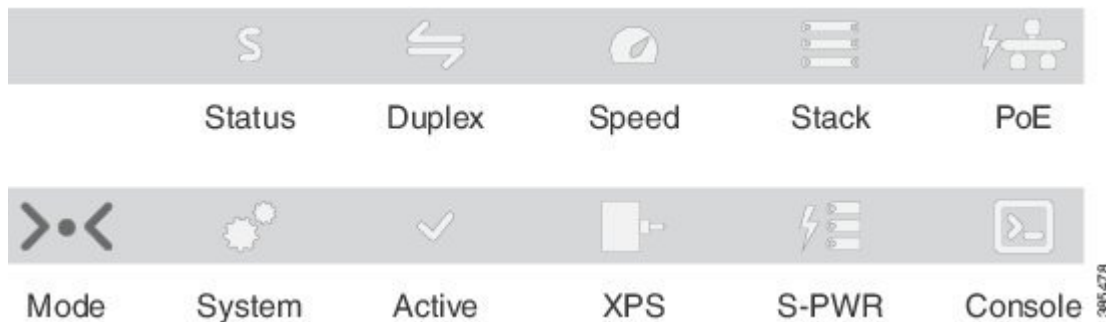



Note XPS and S-PWR LEDs are not applicable to C9300L switches.

USB Console LED

The USB console LED shows whether there is an active USB connection to the port.

Table 6: USB Console LED

LED	Color	Description
USB console port	Green	USB console port is active.
	Off	The USB is disabled.

System LED

Table 7: System LED

Color	System Status
Off	System is not powered on.
Green	System is operating normally.
Blinking green	System is loading the software.
Amber	System is receiving power but is not functioning properly.
Blinking amber	There is a fault with one of the following: <ul style="list-style-type: none"> • Network module (non traffic-related) • Power supply • Fan module

Active LED

Table 8: Active LED

Color	Description
Off	Switch is not the active switch.
Green	Switch is the active switch or a standalone switch.
Slow blinking green	Switch is in stack standby mode.
Amber	An error occurred when the switch was selecting the active switch, or another type of stack error occurred.

STACK LED

The STACK LED shows the sequence of member switches in a stack. Up to nine switches can be members of a stack. The first nine port LEDs show the member number of a switch in a stack.

Figure 9: STACK LED

This figure shows the LEDs on for each switch. When you press the Mode button to select the STACK LED, the corresponding port LEDs will blink green for each switch. For example, for switch 1, port 1 will blink green and the rest of the LEDs will be off. On switch 2, port 2 will blink green and the rest of the LEDs will be off. The same behavior will be seen with the remaining switches in the stack.

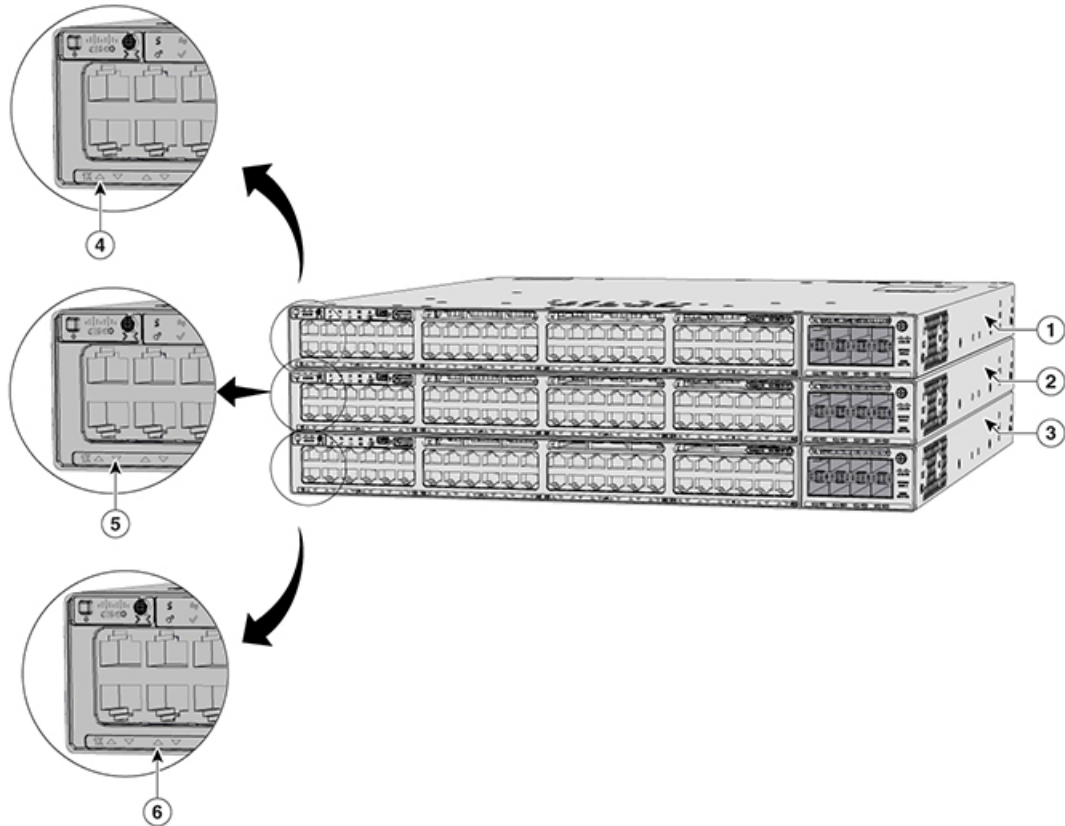

1	Stack member 1	4	LED blinks green to show that this is switch 1 in the stack.
2	Stack member 2	5	LED blinks green to show that this is switch 2 in the stack.
3	Stack member 3	6	LED blinks green to show that this is switch 3 in the stack.

PoE LED

The PoE LED indicates the status of the PoE mode: either PoE, PoE+, or Cisco UPOE.

Table 9: PoE LED

Color	Description
Off	PoE mode is not selected. None of the 10/100/1000 ports have been denied power or are in a fault condition.
Green	PoE mode is selected, and the port LEDs show the PoE mode status.
Blinking amber	PoE mode is not selected. At least one of the 10/100/1000 ports has been denied power, or at least one of the 10/100/1000 ports has a PoE mode fault.

XPS LED



Note This LED is not supported on Cisco Catalyst 9300L Series switches.

Table 10: XPS LED

Color	Description
Off	XPS cable is not installed. Switch is in StackPower mode.
Green	XPS is connected and ready to provide back-up power.
Blinking green	XPS is connected but is unavailable because it is providing power to another device (redundancy has been allocated to a neighboring device).
Amber	The XPS is in standby mode or in a fault condition. See the XPS 2200 documentation for information about the standby mode and fault conditions.
Blinking amber	The power supply in a switch has failed, and the XPS is providing power to that switch (redundancy has been allocated to this device).

For information about the XPS 2200, see the *Cisco eXpandable Power System 2200 Hardware Installation Guide* on Cisco.com:

http://www.cisco.com/go/xps2200_hw

S-PWR LED

Table 11: S-PWR LED

Color	Description
Off	StackPower cable is not connected, or the switch is in standalone mode.
Green	Each StackPower port is connected to another switch.
Blinking green	This appears on the switch in a StackPower ring configuration that detects an open ring or has only one StackPower cable connected.

Color	Description
Amber	There is a fault: load shedding is occurring, a StackPower cable is defective, or an administrative action is required. See the switch software configuration guide for information about configuring StackPower.
Blinking amber	The StackPower budget is not sufficient to meet current power demands.

Port LEDs and Modes

Each Ethernet port, 1-Gigabit Ethernet module slot, and 10-Gigabit Ethernet module slot has a port LED. These port LEDs, as a group or individually, display information about the switch and about the individual ports. The port mode determines the type of information shown by the port LEDs.

To select or change a mode, press the Mode button until the desired mode is highlighted. When you change port modes, the meanings of the port LED colors also change.

When you press the Mode button on any switch in the switch stack, all the stack switches change to show the same selected mode. For example, if you press the Mode button on the active switch to show the SPEED LED, all the other switches in the stack also show the SPEED LED.

Table 12: Port Mode LEDs

Mode LED	Port Mode	Description
STAT	Port status	The port status. This is the default mode.
SPEED	Port speed	The port operating speed: 10, 100, or 1000 Mb/s.
DUPLX	Port duplex mode	The port duplex mode: full duplex or half duplex.
ACTV	Active	The active switch status.
STACK	Stack member status	Stack member status.
	StackWise port status	The StackWise port status. See STACK LED , on page 16.
PoE ¹	The PoE+ port status.	The PoE+ port status.

¹ Only switches with PoE+ ports.

Table 13: Meaning of Switch LED Colors in Different Modes

Port Mode	Port LED Color	Meaning
STAT (port status)	Off	No link, or port was administratively shut down.
	Green	Link present, no activity.
	Blinking green	Activity. Port is sending or receiving data.
	Alternating green-amber	Link fault. Error frames can affect connectivity, and errors such as excessive collisions, CRC errors, and alignment and jabber errors are monitored for a link-fault indication.
	Amber	Port is blocked by Spanning Tree Protocol (STP) and is not forwarding data. After a port is reconfigured, the port LED can be amber for up to 30 seconds as STP checks the switch for possible loops.
	Blinking amber	Port is blocked by STP and is only receiving control frames.
SPEED	10/100/1000/SFP ports	
	Off	Port is operating at 10 Mb/s.
	Green	Port is operating at 100 Mb/s.
	Single green flash (on for 100 ms, off for 1900 ms)	Port is operating at 1000 Mb/s.
	Blinking twice	Port is operating at 2500, 5000 or 10000 Mb/s
	Network module slots	
	Off	Port is not operating.
	Blinking green	Port is operating at up to 10 Gb/s.
DUPLX (duplex)	Off	Port is operating in half duplex.
	Green	Port is operating in full duplex.
ACTV (data active switch)	Off	The switch is not the active switch. Note For a standalone switch, this LED is off.
	Green	The switch is the active switch.
	Amber	Error during active switch election.
	Blinking green	Switch is a standby member of a data stack and assumes active responsibilities if the current active switch fails.

Port Mode	Port LED Color	Meaning
STACK (stack member)	Off	No stack member corresponding to that member number.
	Blinking green	Stack member number.
	Green	Member numbers of other stack member switches.
PoE+ ²	Off	PoE+ is off. If the powered device is receiving power from an AC power source, the port LED is off even if the device is connected to the switch port.
	Green	PoE+ is on. The port LED is green when the switch port is providing power.
	Alternating green-amber	PoE+ is denied because providing power to the powered device will exceed the switch power capacity.
	Blinking amber	PoE+ is off due to a fault or because it has exceeded a limit set in the switch software. Caution PoE+ faults occur when noncompliant cabling or powered devices are connected to a PoE+ port. Use only standard-compliant cabling to connect Cisco prestandard IP Phones and wireless access points or IEEE 802.3af-compliant devices to PoE+ ports. You must remove from the network any cable or device that causes a PoE+ fault.
	Amber	PoE+ for the port has been disabled. Note PoE+ is enabled by default.

² Only switches with PoE or PoE+ ports.

Beacon LED

The UID and the Beacon LED can be turned on by the administrator to indicate that the switch needs attention. It helps the administrator identify the switch. The beacon can be turned on by either pressing the UID button on the switch front panel, or by using the CLI. There is a blue beacon on the front and rear panel of the switch. The blue beacon on the front panel is a button labeled UID, and on the back panel it is a LED labeled BEACON.

Color/State	Description
Solid blue	The operator has indicated that the system needs attention.

Network Module LEDs

Color	Network Module Link Status
Off	Link is off.
Green	Link is on; no activity.
Blinking green	Activity on a link; no faults. Note The LED will blink green even when there is very little control traffic.
Blinking amber	Link is off due to a fault or because it has exceeded a limit set in the switch software. Caution Link faults occur when noncompliant cabling is connected to an SFP/SFP+/SFP28 port. Use only standard-compliant cabling to connect to Cisco SFP/SFP+/SFP28 ports. You must remove from the network any cable or device that causes a link fault.
Amber	Link for the SFP/SFP+/SFP28 has been disabled.

Rear Panel

The switch rear panel includes StackWise connectors, StackPower or XPS connectors, ports, fan modules, and power supply modules.

Figure 10: Rear Panel of a Cisco Catalyst 9300 Series Switch

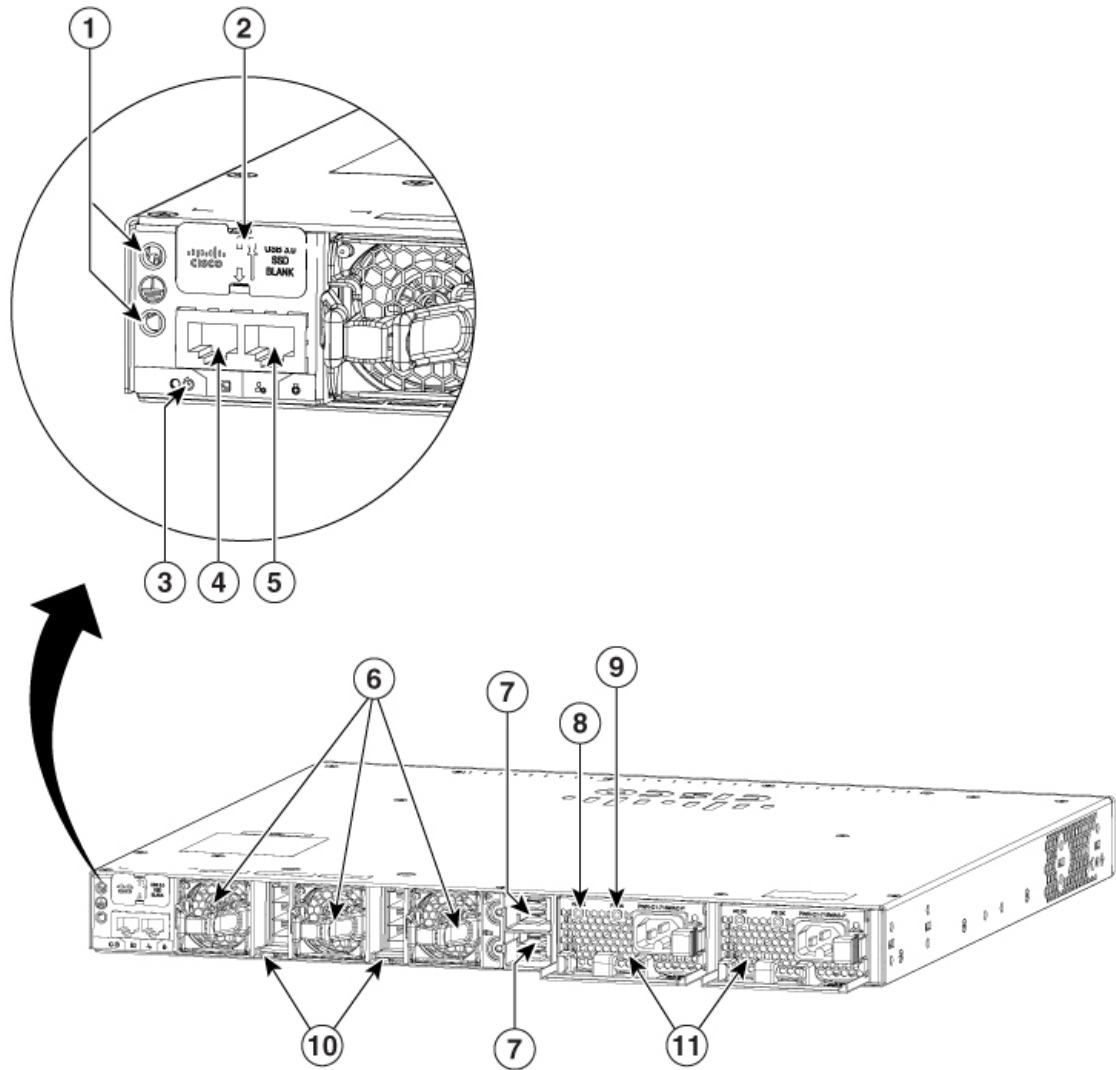

356238

1	Ground connectors	7	StackPower connectors
2	USB3.0-SSD port	8	AC OK (input) status LED
3	BEACON LED	9	PS OK (output) status LED
4	CONSOLE (RJ-45 console port)	10	StackWise-480 port connectors
5	MGMT (RJ-45 10/100/1000 management port)	11	Power supply modules
6	Fan modules	-	-

Figure 11: Rear Panel of a Cisco Catalyst 9300L Series Switch

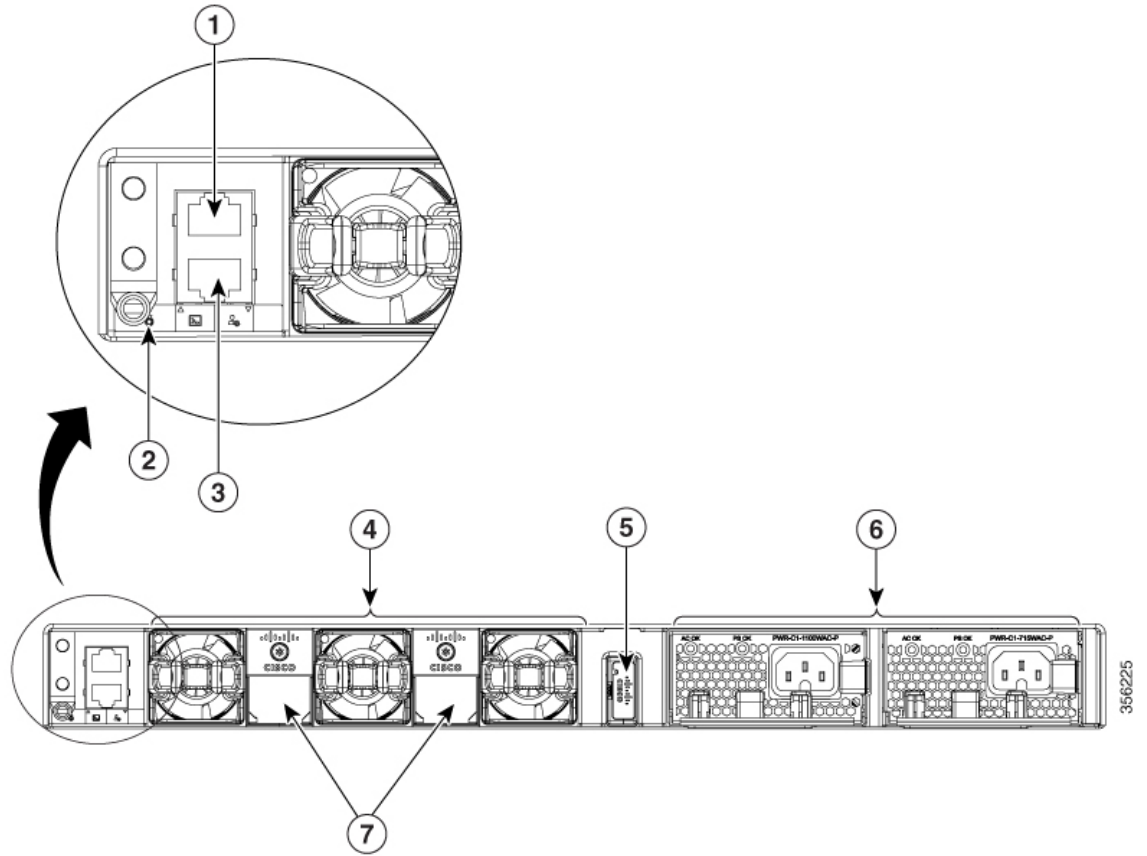

1	CONSOLE (RJ-45 console port)	5	USB3.0 SSD port
2	BEACON LED	6	Power supply modules
3	MGMT (RJ-45 10/100/1000 management port)	7	StackWise-320 port connectors
4	Fan modules	-	-

Figure 12: Rear Panel of a Cisco Catalyst 9300LM Series Switch

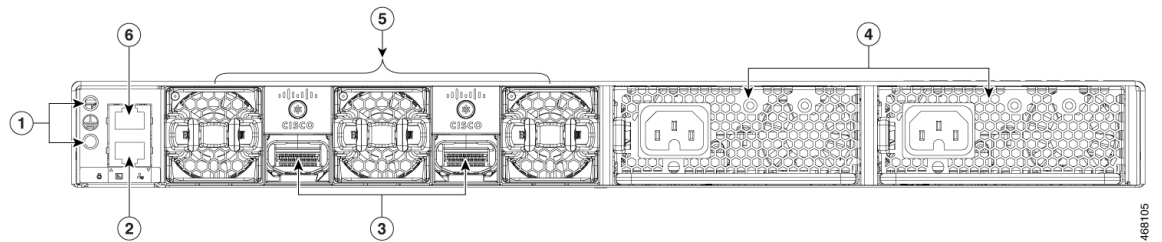

1	Ground connectors	4	Power supply modules
---	-------------------	---	----------------------

2	MGMT (RJ-45 10/100/1000 management port)	5	Fan modules
3	StackWise-320 port connectors	6	CONSOLE (RJ-45 console port)

Figure 13: Rear Panel of a C9300LM-48T-4Y

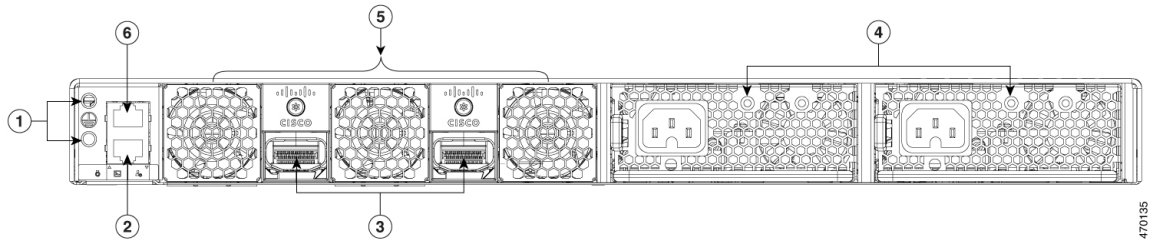

1	Ground connectors	4	Power supply modules
2	MGMT (RJ-45 10/100/1000 management port)	5	Fixed fans
3	StackWise-320 port connectors	6	CONSOLE (RJ-45 console port)

Figure 14: Rear Panel of a Cisco Catalyst 9300X Series Switch

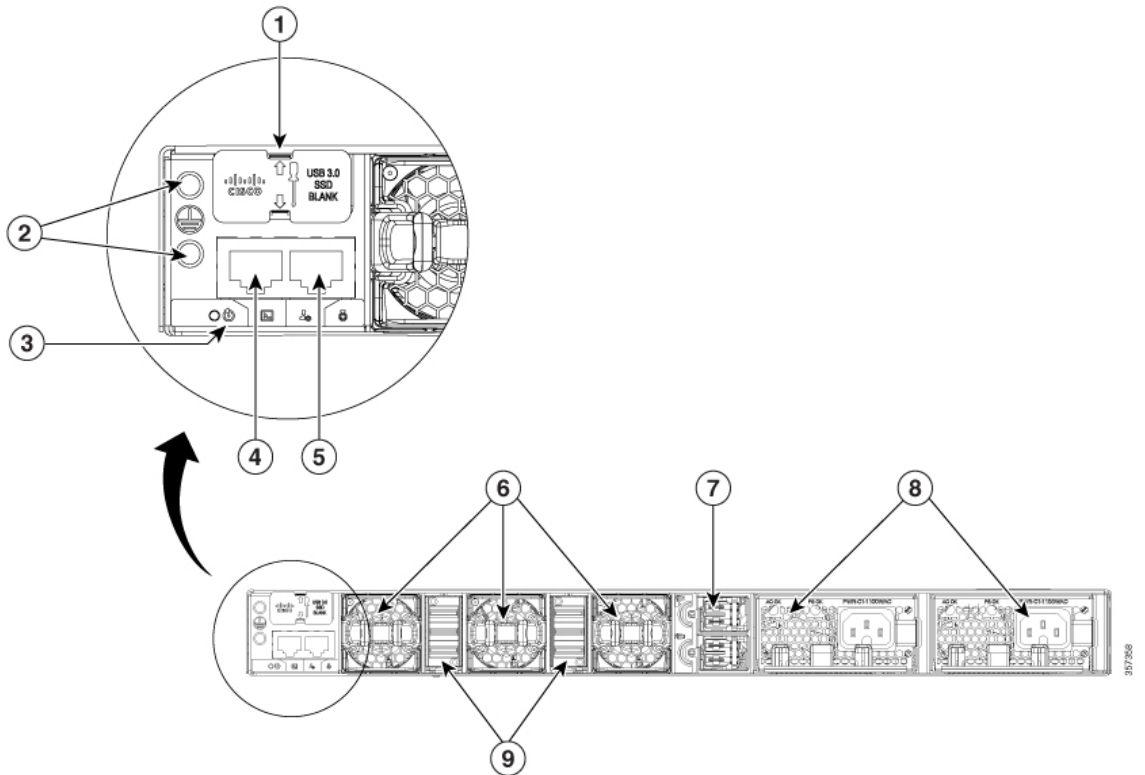

1	USB3.0-SSD port	6	Fan modules
---	-----------------	---	-------------

2	Ground connectors	7	StackPower+ connectors
3	BEACON LED	8	Power supply modules
4	CONSOLE (RJ-45 console port)	9	StackWise-1T port connectors
5	MGMT (RJ-45 management port)	-	-

RFID Tag

The chassis has a built-in, passive RFID tag that uses UHF RFID technology and requires an RFID reader with compatible software. It provides auto-identification capabilities for asset management and tracking. The RFID tags are compatible with the Generation 2 GS1 EPC Global Standard and are ISO 18000-6C compliant. They operate in the 860- to 960-MHz UHF band. For more information, see [Radio Frequency Identification \(RFID\) on Cisco Catalyst 9000 Family Switches White Paper](#).

RJ-45 Console Port LED

Table 14: RJ-45 Console Port LED

Color	RJ-45 Console Port Status
Off	RJ-45 console is disabled. USB console is active.
Green	RJ-45 console is enabled. USB console is disabled.

StackWise Ports

StackWise ports are used to connect switches in StackWise stacking configurations. The switch ships with a 0.5-meter StackWise cable for modular uplink switch models that you can use to connect the StackWise ports. For more information on StackWise cables, see [Connecting the StackWise Cables, on page 60](#).



Caution Use only approved cables, and connect only to similar Cisco equipment. Equipment might be damaged if connected to nonapproved Cisco cables or equipment.

Power Supply Modules

The switches are powered through one or two internal power supply modules. The switches ship with one power supply module by default, and the second power supply can be purchased when the switch is ordered or at a later time.

Following is the list of all the power supply modules supported on Cisco Catalyst 9300 Series Switches. For information about the modules supported on each switch model, see [Power Supply Modules Overview, on page 81](#).

- PWR-C1-350WAC
- PWR-C1-715WAC

- PWR-C1-1100WAC
- PWR-C1-715WDC
- PWR-C1-350WAC-P
- PWR-C1-715WAC-P
- PWR-C1-1100WAC-P
- PWR-C1-1900WAC-P
- PWR-C6-600WAC
- PWR-C6-1KWAC



Note The PWR-C6 power supplies are supported only with C9300LM switches. Also, you cannot use any of the other PWR-C1 power supplies listed here with C9300LM switches.

The switch has two internal power supply module slots. You can use two AC modules or one power supply module and a blank module.

The switch can operate with either one or two active power supply modules or with power supplied by a stack. A switch that is in a StackPower stack can operate with power supplied by other switches in the stack.

[Switch Models, on page 2](#) shows the default power supply module that ships with each switch model. All the power supply modules (except the blank modules) have internal fans. All switches ship with a blank power supply module in the second power supply slot.



Caution Do not operate the switch with one power supply module slot empty. Always install a blank module in the empty slot to keep the operating temperature and fan noise lower.

The following tables show the PoE available and PoE requirements for PoE switch models.

Table 15: Available PoE with Default Power Supply

Switch Model	Default Power Supply	Available PoE
C9300 Series Switches		
C9300-24T	PWR-C1-350WAC-P	-
C9300-48T		-
C9300-24S	PWR-C1-715WAC-P	-
C9300-48S		-
C9300-24P		445 W
C9300-48P		437 W

Switch Model	Default Power Supply	Available PoE
C9300-24H	PWR-C1-1100WAC-P	830 W (PWR-C1-1100WAC)
C9300-48H		822 W (PWR-C1-1100WAC)
C9300-24U		830 W
C9300-48U		822 W
C9300-24UB		830 W
C9300-48UB		822 W
C9300-24UX		560 W
C9300-24UXB		560 W
C9300-48UN		610 W
C9300-48UXM		490 W
C9300L Series Switches		
C9300L-24T-4G	PWR-C1-350WAC-P	-
C9300L-24T-4X		-
C9300L-48T-4G		-
C9300L-48T-4X		-
C9300L-24P-4G	PWR-C1-715WAC-P	505 W
C9300L-24P-4X		505 W
C9300L-48P-4G		505 W
C9300L-48P-4X		505 W
C9300L-48PF-4G	PWR-C1-1100WAC-P	890 W
C9300L-48PF-4X		890 W
C9300L-24UXG-4X		880 W
C9300L-24UXG-2Q		722 W
C9300L-48UXG-4X		675 W
C9300L-48UXG-2Q		675 W
C9300LM Series Switches		
C9300LM-48T-4Y	PWR-C6-600WAC	-
C9300LM-24U-4Y		420 W

Switch Model	Default Power Supply	Available PoE
C9300LM-48U-4Y	PWR-C6-1KWAC	790 W
C9300LM-48UX-4Y		790 W
C9300X Series Switches		
C9300X-12Y	PWR-C1-715WAC-P	-
C9300X-24Y		-
C9300X-48TX		-
C9300X-48HX	PWR-C1-1100WAC-P	590 W
C9300X-48HXN	PWR-C1-1100WAC-P	690 W
C9300X-24HX	PWR-C1-1100WAC-P	735 W



- Note** 1. PWR-C1-1900WAC-P provides 1900 W output power when the nominal input voltage is 230 V. If the nominal input voltage is 115 V, then the output power is limited to 1500 W. See [Table 47: AC Power Cords for PWR-C1-1900WAC-P, on page 119](#) for suitable power cord options.

For more information about power supplies, see [Specifications for the Power Supplies, Switches, and Fan, on page 116](#).

Depending on the power supplies configured, C9300-24H can provide a maximum of 2160 W and C9300-48H can provide a maximum of 2880 W of UPOE+ power.

The power supply modules have two status LEDs.

Table 16: Switch Power Supply Module LEDs

AC or DC OK	Description	PS OK	Description
Off	No AC or DC input power.	Off	Output is disabled, or input is outside operating range (LED is off).
Green	AC or DC input power present.	Green	Power output to switch active.
		Red	Output has failed.

Fan Module

The air circulation system consists of fan modules and power supply modules. All switches except C9300LM-48T-4Y support three internal hot-swappable 12-V fan modules (FAN-T2=). The C9300LM-48T-4Y switch has fixed fans.

When the fan modules are operating properly, a green LED at the top left corner of the fan assembly (viewed from the rear), is ON. If the fan fails, the LED turns to amber. The switch can operate with two operational

fans, but the failed fan should be replaced as soon as possible to avoid a service interruption due to a second fan fault.

The airflow direction is from front-to-rear and side-to-rear. The following illustration shows the airflow pattern for the switches. The blue arrow shows cool airflow, and the red arrow shows warm airflow.

Figure 15: Switch Airflow Pattern

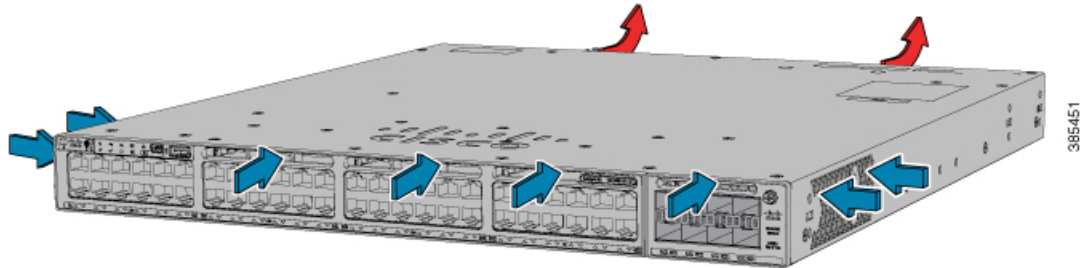

For information about installing a fan module and fan specifications, see [Installing a Fan Module, on page 98](#).

StackPower Connector

The C9300 switches have a StackPower connector for use with Cisco StackPower cables to configure a switch power stack that includes up to four switches. A switch power stack can be configured in redundant or power-sharing mode.

You can order these StackPower cables from your Cisco sales representative:

- CAB-SPWR-30CM (0.3-meter cable)
- CAB-SPWR-150CM (1.5-meter cable)

For details about connecting StackPower cables and StackPower guidelines, see [Planning a StackPower Stack, on page 51](#).

USB 3.0 SSD Port

To support the storage needs on the switch, the Cisco Catalyst 9300 Series Switches provide support for pluggable 120 GB and 240 GB USB 3.0 Solid State Drive (SSD) modules. The USB 3.0 SSD module slot is located at the rear panel of the switch. The storage drive can also be used to save packet captures and trace logs generated by the operating system. The USB 3.0 SSD device is field replaceable.



Note C9300LM switches that have a mount kit to install SSD-240G on the USB Type A port on the front panel. For more information, see [Installing an SSD Module on C9300LM Switches](#).

For information about installing a USB 3.0 SSD module, see [Installing a USB 3.0 SSD, on page 101](#).

Ethernet Management Port

You can connect the switch to a host such as a Windows workstation or a terminal server through the 10/100/1000 Ethernet management port or one of the console ports. The 10/100/1000 Ethernet management port is a VPN routing/forwarding (VRF) interface and uses a RJ-45 crossover or straight-through cable.



Note The 10/100/1000 Ethernet management port is an RJ-45 connector that should be connected to a Windows workstation or a terminal server. Do not connect this port to another port in the same switch or to any port within the same switch stack.

The following table shows the Ethernet management port LED colors and their meanings.

Table 17: Ethernet Management Port LED

Color	Description
Green	Link up but no activity.
Blinking green	Link up and activity.
Off	Link down.

RJ-45 Console Port

The RJ-45 console port connection uses the optional RJ-45-to-DB-9 female cable.

The following table shows the RJ-45 console port LED colors and their meanings.

Table 18: RJ-45 Console LED

Color	Description
Green	RJ-45 console port is active.
Off	The port is not active.

Network Configurations

See the switch software configuration guide for network configuration concepts and examples of using the switch to create dedicated network segments and interconnecting the segments through Fast Ethernet and Gigabit Ethernet connections.



CHAPTER 2

Preparing for Installation

- [Safety Warnings, on page 31](#)
- [Installation Guidelines, on page 33](#)
- [Site Requirements, on page 34](#)

Safety Warnings

This section includes the basic installation caution and warning statements. Read this section before you start the installation procedure. Translations of the warning statements appear in the Regulatory Compliance and Safety Information guide on Cisco.com.



Warning Before working on equipment that is connected to power lines, remove jewelry (including rings, necklaces, and watches). Metal objects will heat up when connected to power and ground and can cause serious burns or weld the metal object to the terminals. Statement 43



Warning Do not stack the chassis on any other equipment. If the chassis falls, it can cause severe bodily injury and equipment damage. Statement 48



Warning Ethernet cables must be shielded when used in a central office environment. Statement 171



Warning Read the wall-mounting instructions carefully before beginning installation. Failure to use the correct hardware or to follow the correct procedures could result in a hazardous situation to people and damage to the system. Statement 378



Warning Do not work on the system or connect or disconnect cables during periods of lightning activity. Statement 1001



Warning Read the installation instructions before connecting the system to the power source. Statement 1004



Warning To prevent bodily injury when mounting or servicing this unit in a rack, you must take special precautions to ensure that the system remains stable. The following guidelines are provided to ensure your safety:

- This unit should be mounted at the bottom of the rack if it is the only unit in the rack.
- When mounting this unit in a partially filled rack, load the rack from the bottom to the top with the heaviest component at the bottom of the rack.
- If the rack is provided with stabilizing devices, install the stabilizers before mounting or servicing the unit in the rack.

Statement 1006



Warning Class 1 laser product. Statement 1008



Warning This unit is intended for installation in restricted access areas. A restricted access area can be accessed only through the use of a special tool, lock and key, or other means of security. Statement 1017



Warning The plug-socket combination must be accessible at all times, because it serves as the main disconnecting device. Statement 1019



Warning Use copper conductors only. Statement 1025



Warning This unit might have more than one power supply connection. All connections must be removed to de-energize the unit. Statement 1028



Warning Only trained and qualified personnel should be allowed to install, replace, or service this equipment. Statement 1030



Warning Ultimate disposal of this product should be handled according to all national laws and regulations. Statement 1040

**Warning**

To prevent the system from overheating, do not operate it in an area that exceeds the maximum recommended ambient temperature of: <113°F (45°C). Statement 1047

**Warning**

This warning symbol means danger. You are in a situation that could cause bodily injury. Before you work on any equipment, be aware of the hazards involved with electrical circuitry and be familiar with standard practices for preventing accidents. Use the statement number provided at the end of each warning to locate its translation in the translated safety warnings that accompanied this device. Statement 1071

**Warning**

Voltages that present a shock hazard may exist on Power over Ethernet (PoE) circuits if interconnections are made using uninsulated exposed metal contacts, conductors, or terminals. Avoid using such interconnection methods, unless the exposed metal parts are located within a restricted access location and users and service people who are authorized within the restricted access location are made aware of the hazard. A restricted access area can be accessed only through the use of a special tool, lock and key or other means of security. Statement 1072

**Warning**

No user-serviceable parts inside. Do not open. Statement 1073

**Warning**

Installation of the equipment must comply with local and national electrical codes. Statement 1074

**Warning**

To prevent airflow restriction, allow clearance around the ventilation openings to be at least: 3 inches (7.6 cm). Statement 1076

**Warning**

Hot surface. Statement 1079

**Note**

The grounding architecture of this product is DC-isolated (DC-I).

Installation Guidelines

When determining where to install the switch, verify that these guidelines are met:

- Clearance to the switch front and rear panel meets these conditions:
 - Front-panel LEDs can be easily read.

- Access to ports is sufficient for unrestricted cabling.
- AC power cord can reach from the AC power outlet to the connector on the switch rear panel.
- The pluggable transceiver module minimum bend radius and connector length is met. See the Cisco pluggable transceiver module documentation for more information.
- Cabling is away from sources of electrical noise, such as radios, power lines, and fluorescent lighting fixtures. Make sure that the cabling is safely away from other devices that might damage the cables.
- For switches with the optional 1100 W or 1900 W power supply module, first rack-mount the switch before installing the power-supply module.
- Make sure that power supply modules and fan modules are securely inserted in the chassis before moving the switch.
- When connecting or disconnecting the power cord on a switch installed with a 350 W or a 715 W power supply that is installed above or below a 1100 W or 1900 W power supply equipped switch, you must remove the 1100 W power supply from the switch to access the power cord.
- Airflow around the switch and through the vents is unrestricted.
- For copper connections on Ethernet ports, cable lengths from the switch to connected devices can be up to 328 feet (100 meters).
- Temperature around the unit does not exceed 113°F (45°C). If the switch is installed in a closed or multirack assembly, the temperature around it might be greater than normal room temperature.
- Humidity around the switch does not exceed 95 percent.
- Altitude at the installation site is not greater than 10,000 feet.
- Cooling mechanisms, such as fans and blowers in the switch, can draw dust and other particles causing contaminant buildup inside the chassis, which can result in system malfunction. You must install this equipment in an environment free from dust and foreign conductive or corrosive materials. For more information, see [Air Quality](#) and [Corrosion](#).

Site Requirements

Planning a proper location for the switch and layout of the equipment rack or wiring closet is essential for successful system operation. These sections describe some of the basic site requirements that you should be aware of as you prepare to install your switch, including the following:

- Environmental factors can adversely affect the performance and longevity of your system.
- Install the switch in an enclosed, secure area, ensuring that only qualified personnel have access to the switch and control of the environment.
- Equipment that is placed too closely together or that is inadequately ventilated may cause system over-temperature conditions, leading to premature component failure.
- Poor equipment placement can make chassis panels inaccessible and difficult to maintain.
- The switch requires a dry, clean, well-ventilated, and air-conditioned environment.

- To ensure normal operation, maintain ambient airflow. If the airflow is blocked or restricted, or if the intake air is too warm, an over-temperature condition may occur. The switch environmental monitor may then shut down the system to protect the system components.
- Multiple switches can be rack mounted with little or no clearance above and below the chassis. However, when mounting a switch in a rack with other equipment, or when placing it on the floor near other equipment, ensure that the exhaust from other equipment does not blow into the air intake vent of the switch chassis.

Temperature

Temperature extremes may cause a system to operate at reduced efficiency and cause a variety of problems, including premature aging and failure of chips, and failure of mechanical devices. Extreme temperature fluctuations may also cause chips to become loose in their sockets. Observe the following guidelines:

- Ensure that the chassis has adequate ventilation.
- Do not place the chassis within a closed-in wall unit or on top of cloth, which can act as thermal insulation.
- Do not place the chassis where it will receive direct sunlight, particularly in the afternoon.
- Do not place the chassis next to a heat source of any kind, including heating vents.
- Adequate ventilation is particularly important at high altitudes. Make sure that all the slots and openings on the system remain unobstructed, especially the fan vent on the chassis.
- Clean the installation site at regular intervals to avoid buildup of dust and debris, which may cause a system to overheat.
- If system is exposed to abnormally low temperatures, allow a two hour warm up period, in ambient temperature no lower than 32°F (0 °C) before turning on.

Failure to observe these guidelines may damage the chassis' internal components.

Air Flow

The switch is designed to be installed in an environment where there is a sufficient volume of air available to cool the supervisor engines, modules, and power supplies. If there are any constraints with regard to the free flow of air through the chassis, or if the ambient air temperature is elevated, the switch environmental monitor may then shut down the system to protect the system components.

To maintain proper air circulation through the switch chassis, we recommend that you maintain a minimum space of 6 inches (15 cm) between a wall and the chassis and power supply unit air intakes or a wall and the chassis and power supply unit hot air exhausts. In situations where the switch chassis are installed in adjacent racks, you should allow a minimum space of 12 inches (30.5 cm) between the air intake of one chassis and the hot air exhaust of another chassis. Failure to maintain adequate spacing between chassis may cause the switch chassis that is drawing in the hot exhaust air to overheat and fail.

If you are installing your switch in an enclosed or partially enclosed rack, we strongly recommend that you verify that your site meets the following guidelines:

- Verify that the ambient air temperature within the enclosed or partially enclosed rack is within the chassis operating temperature limits. After installing the chassis in the rack, power up the chassis and allow the chassis temperature to stabilize (approximately 2 hours).

Measure the ambient air temperature at the chassis air intake grill by positioning an external temperature probe 1 inch (2.5 cm) away from the chassis left side, and centered on the chassis both horizontally and vertically.

Measure the ambient air temperature at the power supply unit air intake grill by positioning an external temperature probe 1 inch (2.5 cm) away from the chassis front, centered on the power supply unit section located above the card slots.

- If the ambient intake air temperature is less than 109°F (45°C) at altitudes of 6,000 feet and below, the rack meets the intake air temperature criterion. At altitudes above that threshold and up to 10,000 feet (3000 m), the air intake should not exceed 104°F (40°C).
- If the ambient intake air temperature exceeds this recommendation, the system may experience minor temperature alarms and increase fan speeds in response.
- If the ambient intake air temperature equals or is greater than 131°F (55°C), the system may experience a major temperature alarm with maximum fan speeds in response. If ambient temperature continues to increase, system will respond with protective shut down.
- Plan ahead. A switch that is currently installed in an enclosed or partially enclosed rack might meet ambient air temperature and air flow requirements at present. However, if you add more chassis to the rack or more modules to a chassis in the rack, the additional heat generated might cause the ambient air temperature at the chassis or power supply unit inlets to exceed recommended conditions which may trigger thermal alarms.

If installation conditions for inlet temperature and airflow are marginal or not fully met, activate the fan tray's NEBS mode, which has more aggressive programming to address restricted spacing and elevated ambient temperatures. This should result in reduced thermal alarms along with greater acoustic noise and increased power consumption associated with higher fan speeds.

Humidity

High-humidity conditions may cause moisture to enter the system, and cause corrosion of internal components and degradation of properties such as electrical resistance, thermal conductivity, physical strength, and size. Extreme moisture buildup inside the system may result in electrical short circuit, which may cause serious damage to the system. Each system is rated for storage and operation in 10 to 95 percent relative humidity, non-condensing with a humidity gradation of 10 percent per hour. Buildings in which climate is controlled by air-conditioning in the warmer months and by heat during the colder months usually maintain an acceptable level of humidity for system equipment. However, if a system is located in an unusually humid location, a dehumidifier should be used to maintain the humidity within an acceptable range.

Altitude

Operating a system at high altitude (low pressure) reduces the efficiency of forced and convection cooling and may result in electrical problems related to arcing and corona effects. This condition may also cause sealed components with internal pressure, such as electrolytic capacitors, to fail or perform at reduced efficiency.

Dust and Particles

Fans cool power supplies and system components by drawing in room-temperature air and exhausting heated air out through various openings in the chassis. However, fans also ingest dust and other particles, causing

contaminant buildup in the system and increased internal chassis temperature. A clean operating environment can greatly reduce the negative effects of dust and other particles, which act as insulators and interfere with the mechanical components in the system.

The standards listed below provide guidelines for acceptable working environments and acceptable levels of suspended particulate matter:

- National Electrical Manufacturers Association (NEMA) Type 1
- International Electrotechnical Commission (IEC) IP-20

Air Quality

Dust is everywhere and often invisible to the naked eye. It consists of fine particles in the air that originate from various sources, such as soil dust lifted by weather, from volcanic eruptions, or pollution. Dust at an installation site may contain small amounts of textile, paper fibers, or minerals from outdoor soil. It may also contain natural contaminants, such as chlorine from the marine environment and industrial contaminants such as sulfur. Ionized dust and debris are dangerous and get attracted to electronic equipment.

The accumulation of dust and debris on electronic equipment has the following adverse effects:

- It increases the operating temperature of the equipment. According to the Arrhenius effect, an increase in the operating temperature leads to a decrease in reliability and life of the equipment.
- The moisture and corrosive elements that are present in the dust can corrode the electronic or mechanical components and cause premature board failure.

These adverse effects are further accelerated by the presence of fans in the data networking equipment that ingest dust and other particles into the equipment. Higher the volume of air that is generated by the fans for cooling, the higher the quantity of dust and particulates that get deposited and trapped inside the equipment. Remove or minimize the presence of dust and particulates at the installation site by following the guidelines mentioned in ANSI 71-04-2013 regulations.



Note In addition to the guidelines mentioned in ANSI 71-04-2013 regulations, follow all applicable guidelines as per site conditions to remove or minimize other contaminants.

Corrosion

Corrosion is a chemical reaction that occurs between electronic components and gases which results in metal deterioration. Corrosion attacks edge connectors, pin connectors, IC plug-in sockets, wirewraps, and all other metal components. Depending on the type and concentration level of the corrosive gases, performance degradation of the components occurs either rapidly or over a period of time. It also leads to blocked currents, brittle connection points, and overheated electrical systems. Corrosion by-products form insulating layers on circuits and causes electronic failure, short circuits, pitting, and metal loss.

A type of corrosion known as creep corrosion, that primarily affects PCBA (Printed Circuit Board Assembly) occurs when the PCBA is subjected to a harsh, and sulfur-rich (hydrogen sulfide) end-use environment over a prolonged period of time. The corrosion begins on certain exposed metals, such as copper and silver, and then creeps along the remaining metal surface either causing electrical short circuits or creating holes. Creep corrosion also occurs on electronic components such as resistors and PCBs.

To prevent corrosion, remove or minimize the presence of dust and particulates at the installation site by following the guidelines mentioned in ANSI 71-04-2013 regulations.

Figure 16: A PCB with Corrosion on its Metal Contacts

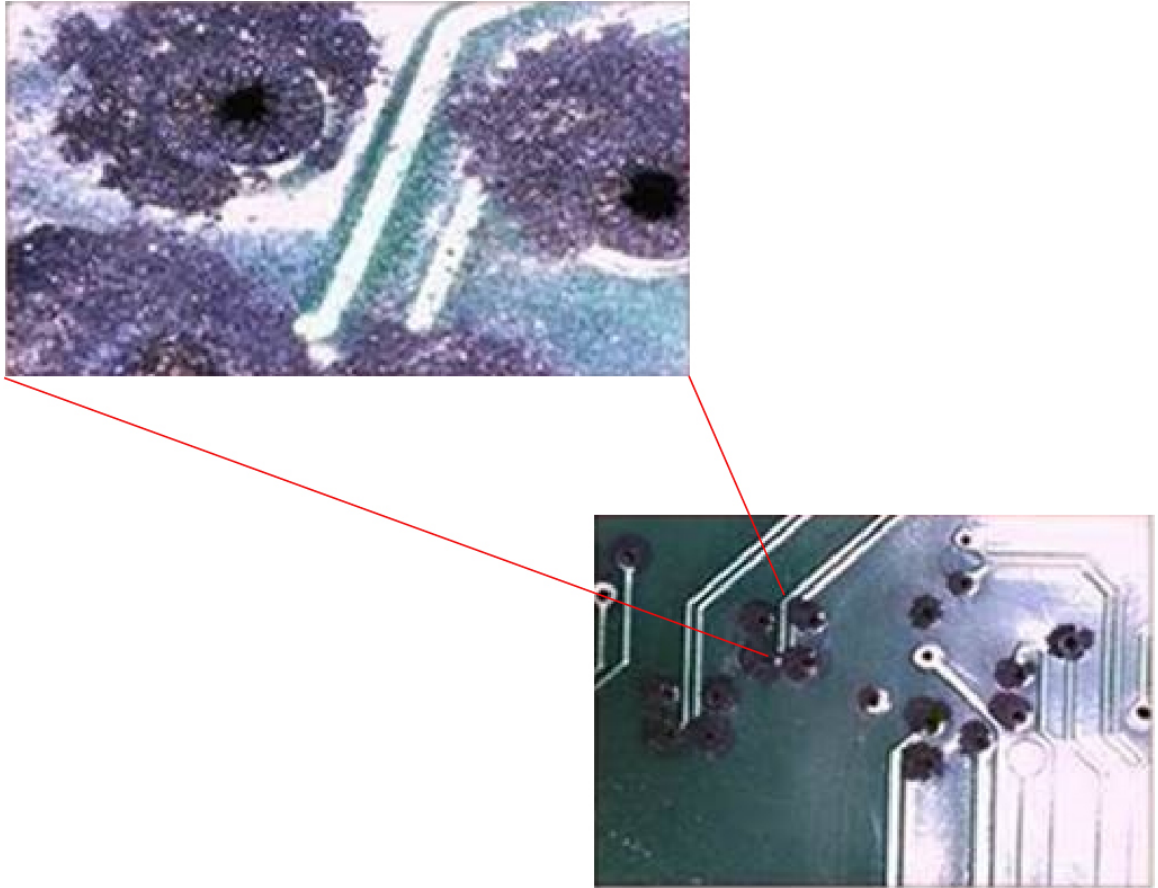

EMI and Radio Frequency Interference

Electro-Magnetic interference (EMI) and radio frequency interference (RFI) from a system can adversely affect devices such as radio and television (TV) receivers operating near the system. Radio frequencies emanating from a system can also interfere with cordless and low-power telephones. Conversely, RFI from high-power telephones can cause spurious characters to appear on the system monitor. RFI is defined as any EMI with a frequency above 10 kilohertz (kHz). This type of interference can travel from the system to other devices through the power cable and power source, or through the air in the form of transmitted radio waves. The Federal Communications Commission (FCC) publishes specific regulations to limit the amount of harmful interference emitted by computing equipment. Each system meets these FCC regulations. To reduce the possibility of EMI and RFI, follow these guidelines:

- Always operate the system with the chassis covers installed.
- Ensure that all chassis slots are covered by a metal filler bracket and that an unused power supply bay has a metal cover plate installed.
- Ensure that the screws on all peripheral cable connectors are securely fastened to their corresponding connectors on the back of the chassis.

- Always use shielded cables with metal connector shells for attaching peripherals to the system.

When wires are run for any significant distance in an electromagnetic field, interference can occur between the field and the signals on the wires. This fact has two implications for the construction of plant wiring:

- Bad wiring practice can result in radio interference emanating from the plant wiring.
- Strong EMI, especially when it is caused by lightning or radio transmitters, can destroy the signal drivers and receivers in the chassis, and even create an electrical hazard by conducting power surges through lines into equipment.



Note To predict and provide a remedy for strong EMI, consult experts in RFI.

If you use twisted-pair cable in your plant wiring, include a good distribution of grounding conductors to reduce EMI. If you exceed the recommended distances, use a high-quality twisted-pair cable with one ground conductor for each data signal when applicable.

If the wires exceed the recommended distances, or if wires pass between buildings, give special consideration to the effect of a lightning strike in your vicinity. The electromagnetic pulse caused by lightning or other high-energy phenomena can easily couple enough energy into unshielded conductors to destroy electronic devices. If you have had problems of this sort in the past, you may want to consult experts in electrical surge suppression and shielding.



Caution The intra-building ports (Copper Based Ethernet Ports) of the equipment or subassembly is suitable for connection to inside a building or unexposed wiring or cabling only. If the intra-building ports of the equipment or subassembly is metallically connected to interfaces that connect to the Out Side Plant (OSP) or its wiring, the metallic-connection **MUST NOT** be more than 6 meters (approximately 20 feet). These interfaces are designed for use as intra-building interfaces only (Type 2, 4, or 4a ports as described in GR-1089-CORE) and require isolation from the exposed OSP cabling. The addition of Primary Protectors is not sufficient protection in order to connect these interfaces metallically to an OSP wiring system.

Shock and Vibration

The equipment complies with the Earthquake, Office, and Transportation Vibration, and Equipment Handling Criteria of GR-63-CORE.

Power Source Interruptions

Systems are especially sensitive to variations in voltage supplied by the AC power source. Overvoltage, undervoltage, and transients (or spikes) can erase data from memory or even cause components to fail. To protect against these types of problems, power wiring ground conductors should always be properly grounded. Also, place the system on a dedicated power circuit (rather than sharing a circuit with other heavy electrical equipment). In general, do not allow the system to share a circuit with any of the following:

- Copy machines
- Air conditioners

- Vacuum cleaners
- Space heaters
- Power tools
- Teletype machines
- Laser printers
- Facsimile machines
- Any other motorized equipment

Besides these appliances, the greatest threats to a system's power supply are surges or blackouts that are caused by electrical storms. Whenever possible, turn off the system and peripherals, if any, and unplug them from their power sources during thunderstorms. If a blackout occurs—even a temporary one—while the system is turned on, turn off the system immediately and disconnect it from the electrical outlet. Leaving the system on may cause problems when the power is restored; all other appliances left on in the area may create large voltage spikes that may damage the system.

System Grounding



Warning To reduce risk of electric shock, when installing or replacing the unit, the ground connection must always be made first and disconnected last.

If your unit has modules, secure them with the provided screws.

You must install a NEBS-compliant system ground as part of the chassis installation process. Chassis installations that rely only on the AC third-prong ground are insufficient to properly and adequately ground the system

Proper grounding practices ensure that the buildings and the installed equipment within them have low-impedance connections and low-voltage differentials between chassis. When you install a system ground, you reduce or prevent shock hazards, chances of equipment damage due to transients, and the potential for data corruption.

Without proper and complete system grounding, you run the risk of increased component damage due to ESD. Additionally, you have a greatly increased chance of data corruption, system lockup, and frequent system reboot situations by not using a system ground.



Caution Installations that rely solely on system grounding that uses only an AC third-prong ground run a substantially greater risk of equipment problems and data corruption than those installations that use both the AC third-prong ground and a properly installed system ground.

The following table lists some general grounding practice guidelines.

Table 19: Grounding Practice Guidelines

Environment	Electromagnetic Noise Severity Level	Grounding Recommendations
<p>Commercial building is subjected to direct lightning strikes.</p> <p>For example, some places in the United States, such as Florida, are prone to more lightning strikes than other areas.</p>	High	<p>All lightning protection devices must be installed in strict accordance with manufacturer recommendations.</p> <p>Conductors carrying lightning current should be spaced away from power and data lines in accordance with applicable recommendations and building codes. Best grounding practices must be closely followed.</p>
<p>Commercial building is located in an area where lightning storms occur frequently, but is not prone to direct lightning strikes.</p>	High	<p>Best grounding practices must be closely followed.</p>
<p>Commercial building contains a mix of information technology equipment and industrial equipment, such as welding.</p>	Medium to High	<p>Best grounding practices must be closely followed.</p>
<p>Existing commercial building is not subject to natural environmental noise or man-made industrial noise. This building contains a standard office environment. This installation has a history of malfunction due to electromagnetic noise.</p>	Medium	<p>Best grounding practices must be closely followed. Determine source and cause of noise if possible, and mitigate as closely as possible at the noise source or reduce coupling from the noise source to the victim equipment.</p>
<p>New commercial building is not subject to natural environmental noise or man-made industrial noise. This building contains a standard office environment.</p>	Low	<p>Best grounding practices should be followed as closely as possible. Electromagnetic noise problems are not anticipated, but installing a best-practice grounding system in a new building is often the least expensive route, and the best way to plan for the future.</p>
<p>Existing commercial building is not subject to natural environmental noise or man-made industrial noise. This building contains a standard office environment.</p>	Low	<p>Best grounding practices should be followed as much as possible. Electromagnetic noise problems are not anticipated, but installing a best-practice grounding system is always recommended.</p>



Note In all situations, grounding practices must comply with Section 250 of the National Electric Code (NEC) requirements or local laws and regulations. A 6 AWG grounding wire is preferred from the chassis to the rack ground or directly to the common bonding network (CBN). The equipment rack should also be connected to the CBN with a 6 AWG grounding wire.



Note Grounding lugs must be installed on the location marked on the chassis only.



Note Always ensure that all of the modules are completely installed and that the captive installation screws are fully tightened. In addition, ensure that all the I/O cables and power cords are properly seated. These practices are normal installation practices and must be followed in all installations.

Maintaining Safety with Electricity

When working on electrical equipment, follow these guidelines:

- Do not work alone if potentially hazardous conditions exist anywhere in your work space.
- Never assume that power is disconnected from a circuit; always check the circuit before working on it.
- When the power is switched off, put a lock-box on the circuit, so that no one can accidentally switch it on.
- Look carefully for possible hazards in your work area, such as damp floors, ungrounded power extension cables, frayed or damaged power cords, and missing safety grounds.
- If an electrical accident occurs, proceed as follows:
 - Use extreme caution; do not become a victim yourself.
 - Disconnect power from the system.
 - Seek medical attention, if necessary.
- Use the product within its marked electrical ratings and product usage instructions.
- Install the product in compliance with local and national electrical codes.
- If any of the following conditions occur, contact the Cisco Technical Assistance Center:
 - The power cable or plug is damaged.
 - An object has fallen into the product.
 - The product has been exposed to water or other liquids.
 - The product has been dropped or shows signs of damage.
 - The product does not operate correctly when you follow the operating instructions.

- Use the correct external power source. Operate the product only from the type of power source indicated on the electrical ratings label. If you are not sure of the type of power source required, consult a local electrician.
- To help prevent electrical shock, plug all the power cables into properly grounded electrical outlets. These power cables are equipped with three-prong plugs to ensure proper grounding. Do not use adapter plugs or remove the grounding prong from a power cable.
- Observe power strip ratings. Make sure that the total current rating of all products that are plugged into the power strip does not exceed 80 percent of the power strip rating.
- Do not modify power cables or plugs yourself. Consult with a licensed electrician or your power company for site modifications. Always follow your local and national wiring codes.

Preventing ESD Damage

ESD damage might occur when modules or other FRUs are improperly handled, resulting in intermittent or complete failure of the modules or FRUs. Modules consist of printed circuit boards that are fixed in metal carriers. EMI shielding and connectors are integral components of a carrier. Although the metal carrier helps to protect the board from ESD, always use an ESD-grounding strap when handling modules. To prevent ESD damage, follow these guidelines:

- Always use an ESD wrist or ankle strap and ensure that it makes good skin contact.
- Connect the equipment end of the strap to an unfinished chassis surface.
- When installing a component, use an available ejector lever to properly seat the bus connectors in the backplane or midplane. These devices prevent accidental removal, provide proper grounding for the system, and help to ensure that bus connectors are properly seated.
- When removing a component, use an available ejector lever to release the bus connectors from the backplane or midplane.
- Handle carriers by available handles or edges only; avoid touching the printed circuit boards or connectors.
- Place a removed component board-side-up on an antistatic surface or in a static-shielding container. If you plan to return the component to the factory, immediately place it in a static-shielding container.
- Avoid contact between the printed circuit boards and clothing. The wrist strap only protects components from ESD voltages on the body; ESD voltages on clothing can still cause damage.
- Never attempt to remove the printed circuit board from the metal carrier.



CHAPTER 3

Installing a Switch

For initial switch setup, assigning the switch IP address, and powering on information, see the switch getting started guide on Cisco.com.

This chapter contains these topics:

- [Shipping Box Contents, on page 45](#)
- [Tools and Equipment, on page 47](#)
- [Verifying Switch Operation, on page 47](#)
- [Planning a Switch Data Stack, on page 47](#)
- [Data Stack Cabling Configurations, on page 48](#)
- [Planning a StackPower Stack, on page 51](#)
- [StackPower Cabling Configurations, on page 52](#)
- [Installing the Switch, on page 54](#)
- [Connecting the StackWise Cables, on page 60](#)
- [Connecting to the StackPower Ports, on page 64](#)
- [Installing a Network Module in the Switch, on page 64](#)
- [Installing and Removing Cisco Pluggable Transceiver Modules, on page 64](#)
- [Connecting Devices to the Ethernet Ports, on page 64](#)

Shipping Box Contents

The shipping box contains the model of the switch you ordered and other components needed for installation. Some components are optional, depending on your order.



Note Verify that you have received these items. If any item is missing or damaged, contact your Cisco representative or reseller for instructions.

Figure 17: Components Delivered in the Shipping Box

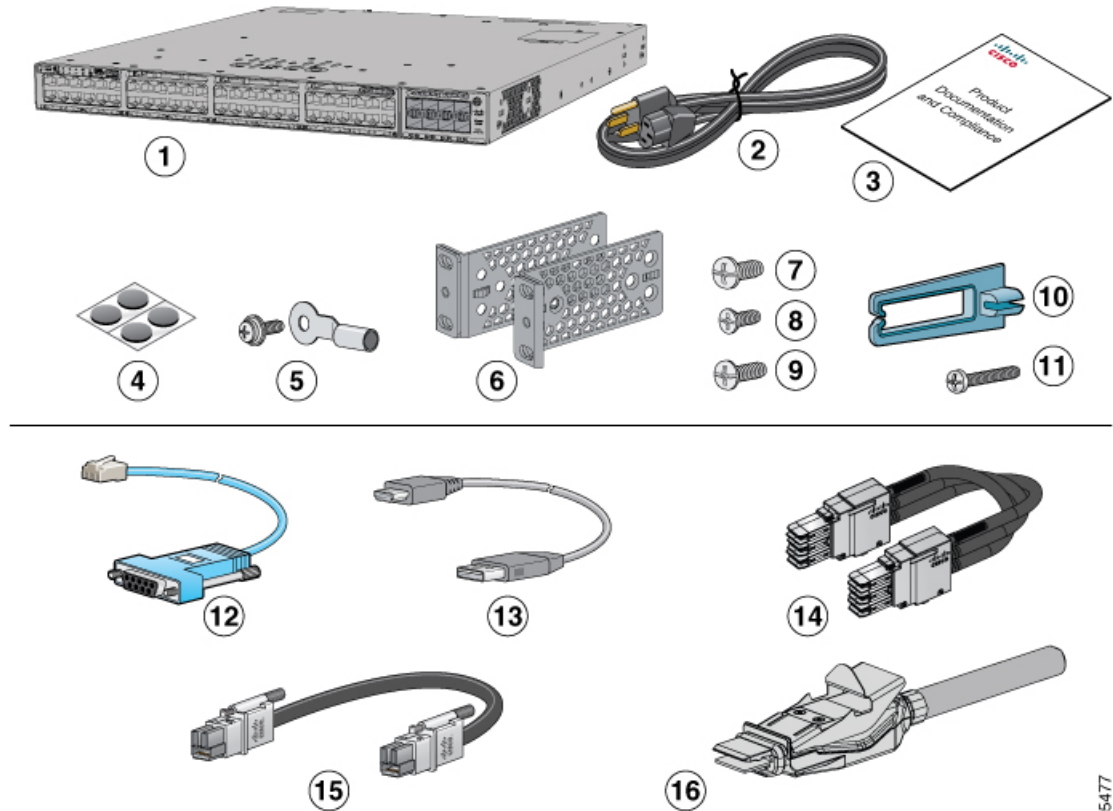

985477

1	Cisco Catalyst 9300 Series switch with optional network module ¹ (power supply and fan modules not shown)	9	Eight number-8 Phillips flat-head screws
2	AC power cord	10	Cable guide
3	Product documentation and compliance document	11	M4.0 x 20mm Phillips pan-head screw
4	Four rubber mounting feet	12	(Optional) RJ-45 console cable
5	Ground lug screw and ring terminal	13	(Optional) USB console cable
6	Two 19-inch mounting brackets	14	(Optional) StackWise-480/1T cable (0.5-meter, 1-meter, or 3-meter)
7	Four number-12 pan-head screws	15	(Optional) StackPower cable (0.3-meter or 1.5-meter)
8	Four number-10 pan-head screws	16	(Optional) StackWise-320 cable



Note 1. The item is orderable.

Tools and Equipment

Obtain these necessary tools:

- A Number-2 Phillips screwdriver.

Verifying Switch Operation

Before you install the switch in a rack, or on a table or shelf, power on the switch and verify that it passes POST.

To power on the switch, plug one end of the AC power cord into the switch AC power connector, and plug the other end into an AC power outlet.

As the switch powers on, it begins the POST, a series of tests that runs automatically to ensure that the switch functions properly. LEDs can blink during the test. The SYST LED blinks green, and the other LEDs remain solid green.

When the switch completes POST successfully, the SYST LED remains green. The other LEDs turn off and then reflect the switch operating status. If a switch fails POST, the SYST LED turns amber.

POST failures are usually fatal. Call Cisco technical support representative if your switch fails POST.

After a successful POST, unplug the power cord from the switch and install the switch in a rack, on a table, or on a shelf.



Warning Attach only the following Cisco external power system to the switch: Cisco XPS 2200 Statement 387

Planning a Switch Data Stack

Cisco Catalyst 9300 switches can share bandwidth by using data stacking. The following table lists the supported stacking options:

Table 20: Supported Stacking Options

Switch Model	Stacking Option	Supported Bandwidth
C9300X modular uplinks	StackWise-1T	1 Tbps
C9300 modular uplinks	StackWise-480	480 Gbps
C9300L fixed uplinks	StackWise-320	320 Gbps

Mixed stacking between C9300X and C9300 switches are supported at StackWise-480 speed. However, you cannot stack fixed uplink switches with modular uplink switches or other Cisco Catalyst switches.

Switch Stacking and Power Stacking Guidelines

Before connecting the switches in a stack, ensure that you read these stacking guidelines:

- Size of the switch and any optional power supply module. The 1100 W/1900 W power supply module is longer than the other modules. Stacking switches with the same power supply modules together makes it easier to cable the switches.
- Length of cable. Depending on the configurations that you have, you might need different sized cables. If you do not specify the length of the StackWise cable, the 0.5 meter cable is supplied. If you need the 1 meter cable or the 3 meter cable, you can order it from your Cisco supplier. For cable part numbers, see [StackWise Accessories, on page 123](#). The [Data Stack Cabling Configurations, on page 48](#) provides examples of recommended configurations.
- For rack mounted switch stacks that are members of a StackPower stack as well as a data stack, see [Planning a StackPower Stack, on page 51](#).
- Up to four switches can be configured in a StackPower stack using the StackPower connector at the rear of the switch. However, with XPS-2200, you can configure up to nine C9300 switches in a StackPower stack. Currently, C9300X switches do not support XPS-2200.

Data Stack Cabling Configurations

This is an example of a recommended configuration that uses the supplied 0.5-meter StackWise cable. In this example, the switches are stacked in a vertical rack or on a table. This configuration provides redundant connections. The configuration example uses the supplied 0.5-meter StackWise cable. The example shows the full-ring configuration that provides redundant connections.

Figure 18: Data Stacking the Switches in a Rack or on a Table Using the 0.5-meter StackWise Cables

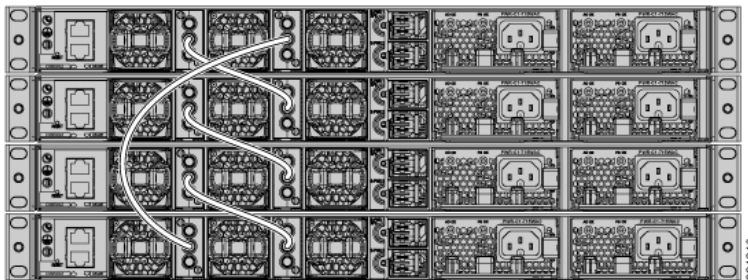

This example shows a recommended configuration when the switches are mounted side-by-side. Use the 1-meter and the 3-meter StackWise cables to connect the switches. This configuration provides redundant connections.

Figure 19: Data Stacking in a Side-by-Side Mounting



Data Stack Bandwidth and Partitioning Examples

This section provides examples of data stack bandwidth and possible data stack partitioning. The figure shows a data stack of switches that provides full bandwidth and redundant StackWise cable connections.

Figure 20: Example of a Data Stack with Full Bandwidth Connections

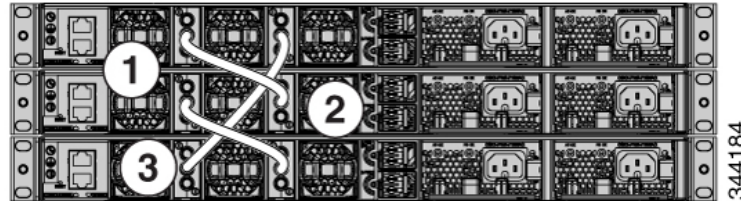

This figure shows an example of a stack of switches with incomplete StackWise cabling connections. This stack provides only half bandwidth and does not have redundant connections.

Figure 21: Example of a Data Stack with Half Bandwidth Connections

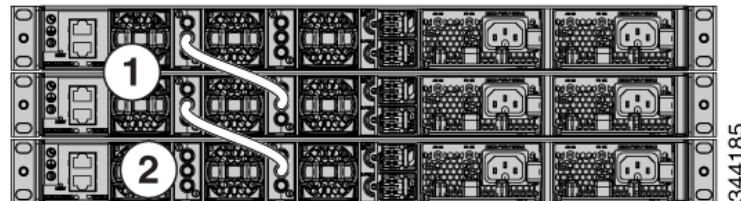

The figures below show data stacks of switches with failover conditions. In this figure, the StackWise cable is bad in link 2. Therefore, this stack provides only half bandwidth and does not have redundant connections.

Figure 22: Example of a Data Stack with a Failover Condition

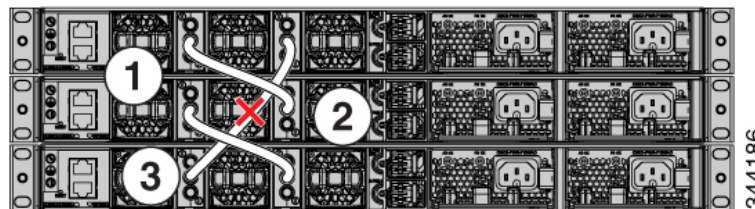

In this figure, link 2 is bad. Therefore, this stack partitions into two stacks, and the top and bottom switches become the active switch in the stack. If the bottom switch is a member (not active or standby switch), it reloads.

Figure 23: Example of a Partitioned Data Stack with a Failover Condition

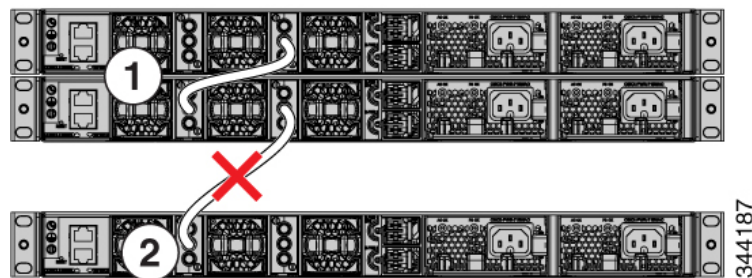

Power-On Sequence for Switch Stacks

Consider these guidelines before you power on the switches in a stack:

- The sequence in which the switches are first powered on might affect the switch that becomes the stack master.
- There are two ways to elect an active switch:
 - If you want a particular switch to become the active switch, configure it with the highest priority. Among switches with same priority, the switch with the lowest MAC address becomes the active switch.
 - If you want a particular switch to become the active switch, power on that switch first. This switch remains the active switch until a reelection is required. After 2 minutes, power on the other switches in the stack. If you have no preference as to which switch becomes the active switch, power on all the switches in the stack within 1 minute. These switches participate in the active switch election. Switches powered on after 2 minutes do not participate in the election.

If changes are made to the stack without powering down the switches, the following results can occur:

- If two operating partial ring stacks are connected together using a stack cable, a stack merge can take place. This situation reloads the whole stack (all switches in the stack).
- If some switches in the stack are completely separated from the stack, a stack split can occur.
- A stack split can occur on a full ring stack if:
 - More than one running switch is removed without powering down.
 - More than one stack cable is removed without powering down.
- A stack split can occur in a partial ring stack if:
 - A switch is removed without powering down.
 - A stack cable is removed without powering down.
- In a split stack, depending on where the active and standby switches are located, either two stacks might be formed (with the standby taking over as the new active switch in the newly formed stack) or all the members in the newly formed stack might reload.



Note These results depend on how the switches are connected. You can remove two or more switches from the stack without splitting the stack.

For conditions that can cause a stack reelection or to manually elect the active switch, see the stacking software configuration guide on Cisco.com at this URL: <http://www.cisco.com/go/c9300>.

Planning a StackPower Stack

StackPower Stacking Guidelines

You can configure a StackPower stack for either power sharing or redundancy. In power-sharing mode, the power of all the power supplies in the stack is aggregated and distributed among the stack members.

In redundant mode, when the total power budget of the stack is calculated, the wattage of the largest power supply is not included. That power is held in reserve and used to maintain power to switches and attached devices when one power supply fails. Following the failure of a power supply, the StackPower mode becomes power sharing.



Note Power-sharing mode is the recommended configuration for Cisco Catalyst 9300 Series Switches.

For general concepts and management procedures for switch power stacks, see the Software Configuration Guide on Cisco.com.

Before connecting the switches in a power stack, read the following guidelines:

- C9300 and C9300X switches support Cisco StackPower providing up to 1000 W of power in nominal conditions and 2400 W of power in failure conditions across a power stack. Cisco StackPower is not supported in C9300L switches.
- A switch power stack can include a maximum of four switches in a ring topology and nine switches in a star topology. Currently, C9300X switches do not provide support for XPS-2200.
- Size of the switch and any optional power supply module. The 1100 W/1900 W power supply module is 1.5 inches (3.81 cm) longer than the other modules, and with the attached cable retention clip, it extends 3 inches (7.62 cm) from the switch chassis. Stacking switches with the same power supply modules together makes it easier to cable the switches. For switch dimensions, see Appendix A, “Technical Specifications.”
- Length of cable. Depending on the configurations that you have, you might need different sized cables. If you do not specify the length of the StackPower cable, the 0.3 meter cable is supplied. If you need the 1.5 meter cable, you can order it from your Cisco supplier. For cable part numbers, see [StackPower Connector, on page 29](#). The [StackPower Cabling Configurations, on page 52](#) provides examples of recommended configurations.
- For rack mounted switch stacks that are members of a data stack and a StackPower stack, see [Switch Stacking and Power Stacking Guidelines, on page 48](#)

StackPower Cabling Configurations

This section describes the recommended cabling configurations for a StackPower stack. There are two types of StackPower cables.

The cable in the figure connects a switch to another switch in a power stack or with an XPS. StackPower cables have color bands on the cable ends:

- The cable end with the green band can connect only to a switch.
- The cable end with the yellow band can connect to a switch or an XPS.

The cable is available in two lengths.

Part Number	Cable Type	Length
CAB-SPWR-30CM	StackPower Cable	0.3 meter
CAB-SPWR-150CM	StackPower Cable	1.5 meter

Figure 24: StackPower Cable for Use with Cisco Catalyst 9300 Series Switches

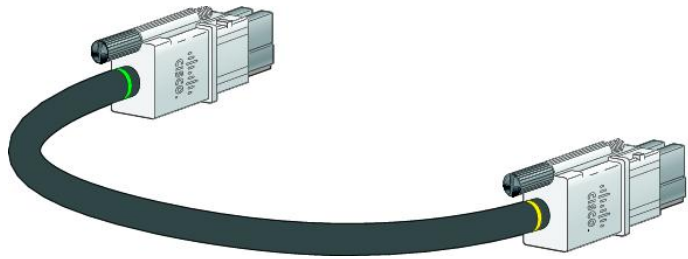

This figure shows a ring configuration using both of the supplied 0.3-meter StackPower cables and one 1.5-meter cable. In the examples that follow, the switches are stacked in a vertical rack or on a table.

Figure 25: StackPower Ring Topology

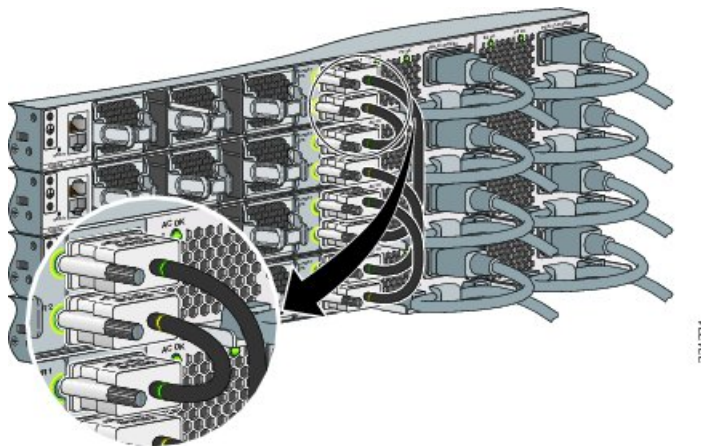

This figure shows 8 switches connected in a star topology.

Figure 26: StackPower Star Topology

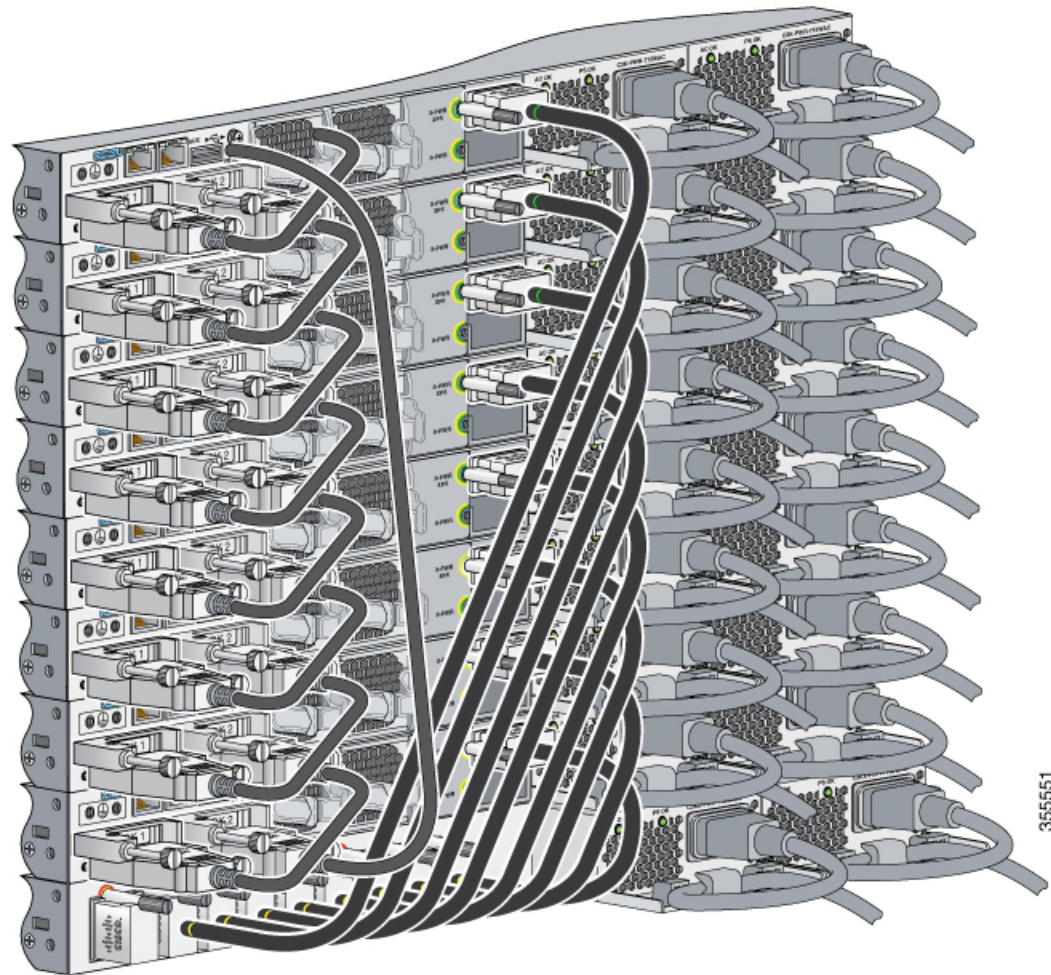

StackPower Partitioning Examples

These figures show StackPower stacks of switches with failover conditions.

In the following figure, the StackPower cable 2 is faulty. This is considered a broken ring and is a fault condition. Power is still shared across the stack, but this condition will place a limitation on power budgeting and the number of high priority ports it can protect in the case of any further failures such as failure of power supply, AC mains, StackPower port and so on. StackPower is not intended for secondary failures and hence restoration of the failed component or power should be done immediately.

Figure 27: Example of a StackPower Stack with a Failover Condition

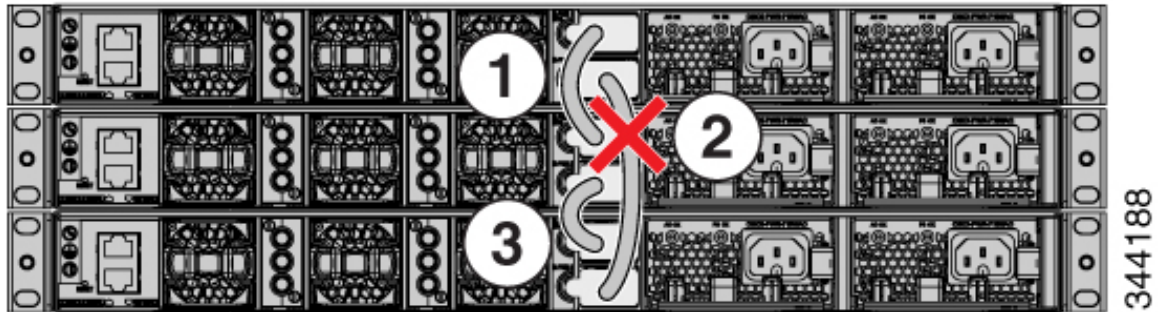

In the following figure, StackPower port B on the center switch has failed and the stack partitions into two stacks. The top two switches share power, and the bottom switch is now a separate stack. After initial failure of cable 2, any further failure of a port is considered a double fault, which a StackPower cannot handle. A double fault could result in unintended high priority ports being shut. If you are unable to physically restore a bad cable, adjust port priorities and restore any offline supplies, as available.

Figure 28: Example of a Partitioned StackPower Stack with a Failover Condition

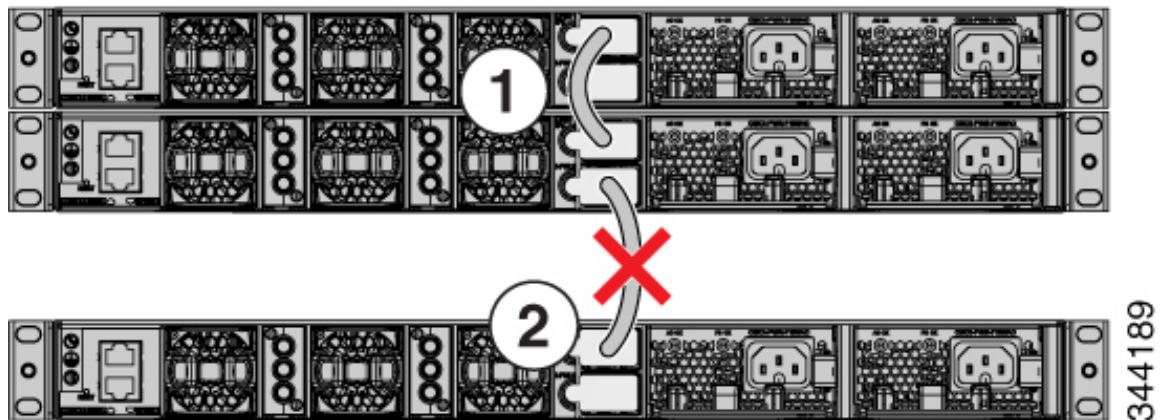

Installing the Switch

Rack-Mounting

Installation in racks other than 19-inch racks requires a bracket kit not included with the switch.

**Warning**

To prevent bodily injury when mounting or servicing this unit in a rack, you must take special precautions to ensure that the system remains stable. The following guidelines are provided to ensure your safety:

- This unit should be mounted at the bottom of the rack if it is the only unit in the rack.
- When mounting this unit in a partially filled rack, load the rack from the bottom to the top with the heaviest component at the bottom of the rack.
- If the rack is provided with stabilizing devices, install the stabilizers before mounting or servicing the unit in the rack.

Statement 1006

The following figure shows the standard 19-inch brackets and other optional mounting brackets. You can order the optional brackets from your Cisco sales representative.

Figure 29: Rack-Mounting Brackets

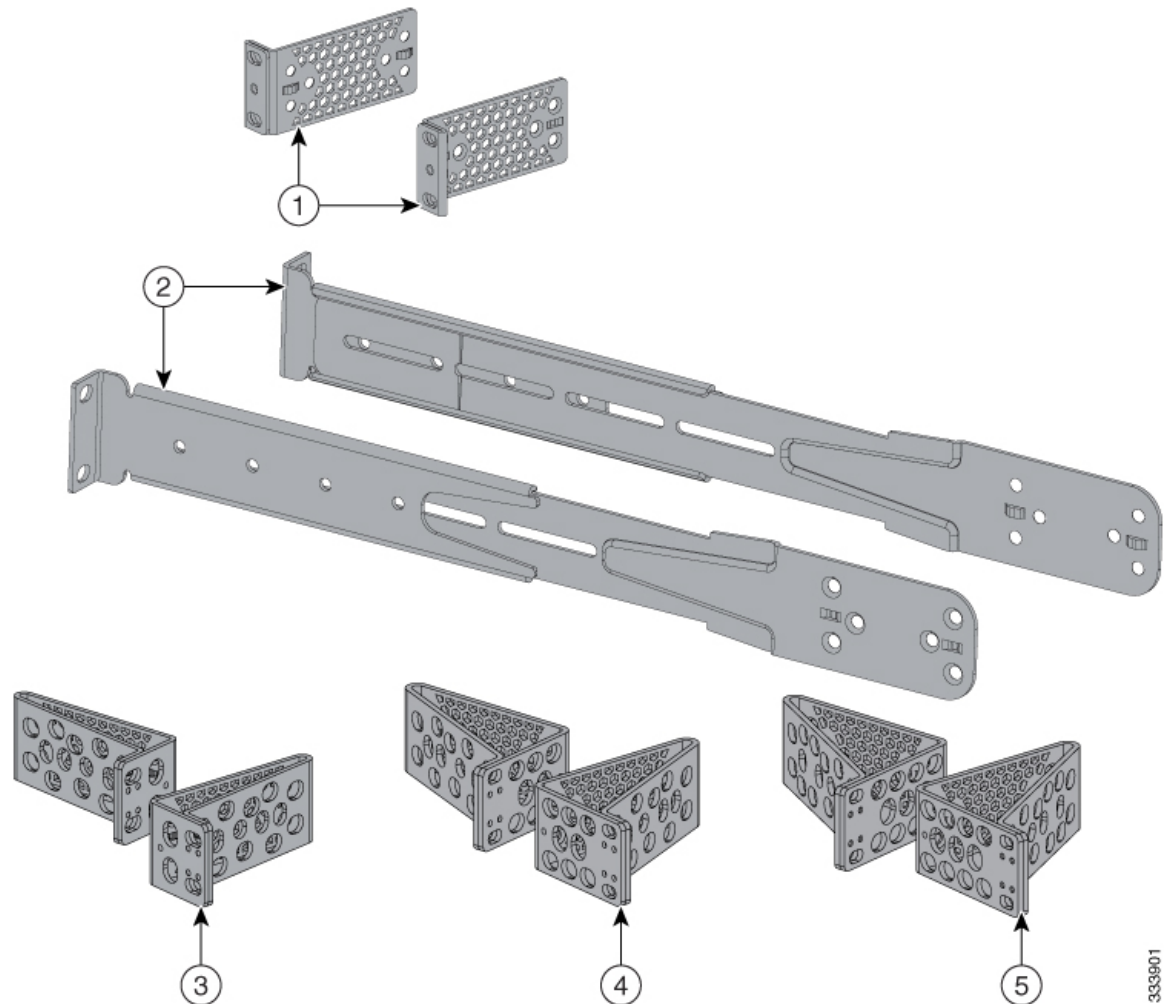

333901

1	19-inch brackets (ACC-KIT-T1=)	4	23-inch brackets (RACK-KIT-T1=)
2	Extension rails and 5 brackets for four-point mounting, includes 19-inch brackets (4PT-KIT-T2=)	5	24-inch brackets (RACK-KIT-T1=)
3	ETSI brackets (RACK-KIT-T1=)	-	-

Attaching the Rack-Mount Brackets

Before you begin

You can use the minimum recommended number of two screws for installing the rack-mount bracket to each side of the switch. If required, while mounting, you can use the additional four screws provided in the accessory kit.

Procedure

- Step 1** Use two Phillips flat-head screws to attach the long side of the bracket to each side of the switch for the front or rear mounting positions.

Figure 30: Attaching 19-inches Rack Mount Brackets and Extension Rails

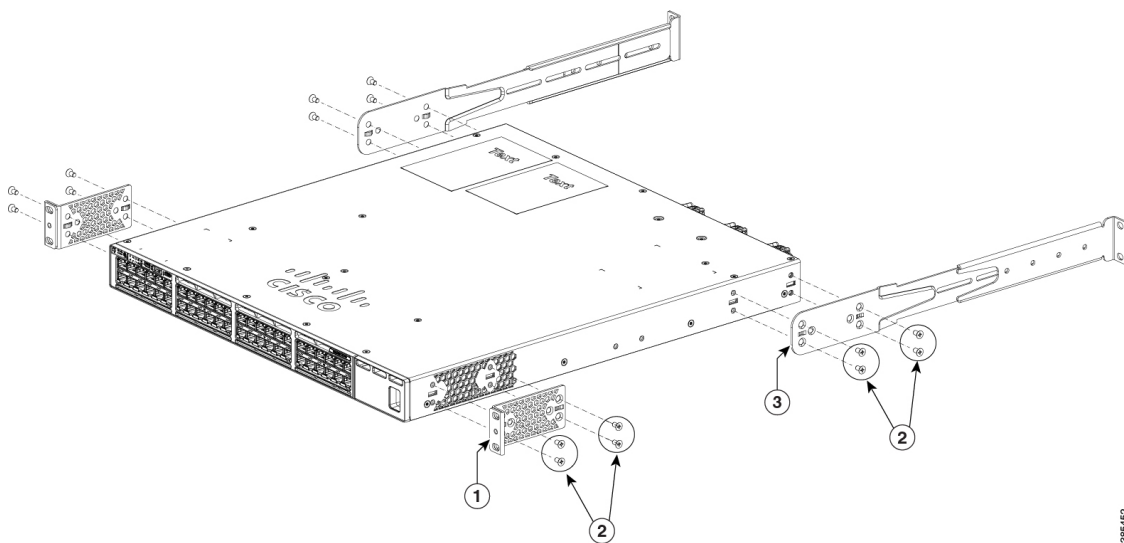

1	19-inch bracket	3	19-inch extension rail
2	Number-8 Phillips flat-head screws (48-2927-01)	-	-

- Step 2** For Network Equipment-Building Standards (NEBS) compliant installations, perform the following steps:

- a) Stick the labels available with CAT-A-AIRFLOW kit on to each side of the switch as shown in the following illustration. Make sure you align the holes in the labels with the screw holes in the chassis.
- b) Secure the brackets to the chassis using the flat head screws provided with the bracket.

Note NEBS is supported only with four-point mounting.

Figure 31: Attaching the NEBS-Compliant Air Vent Label to the Switch

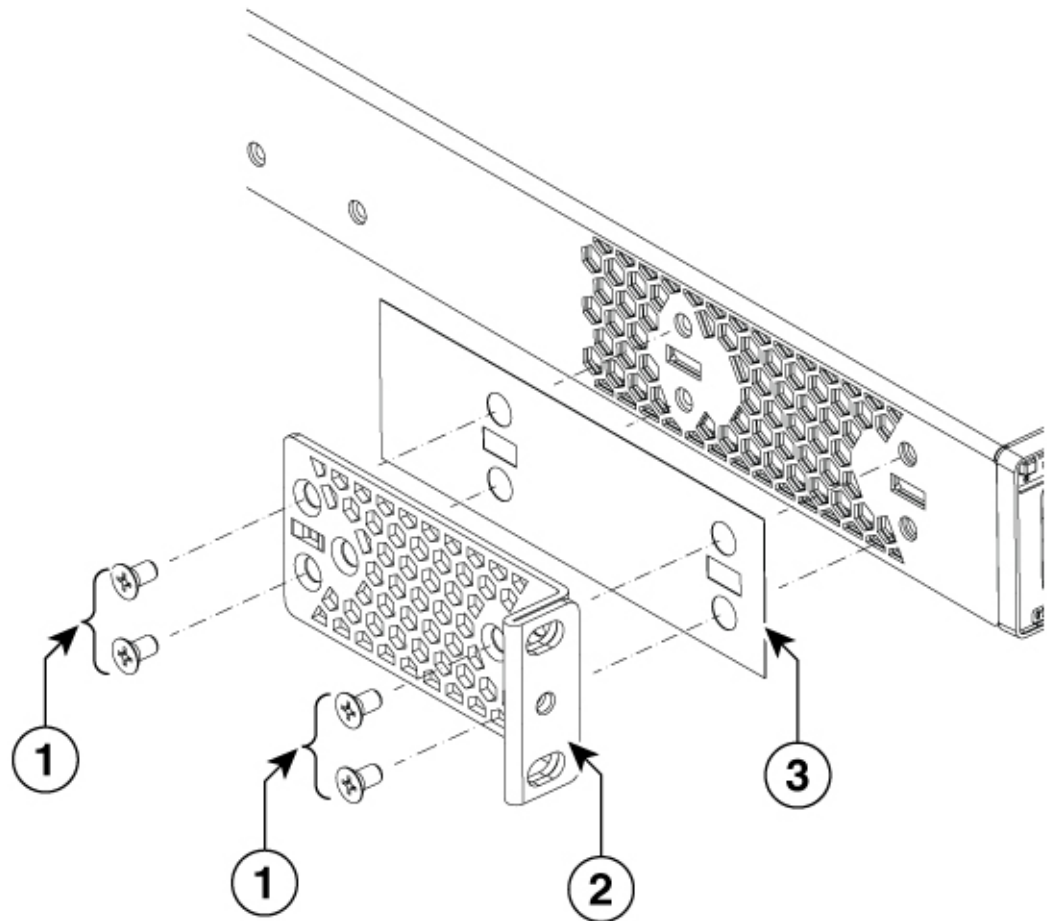

356131

1	Number-8 Phillips flat-head screws	3	NEBS-compliant CAT-A-AIRFLOW kit
2	19-inch bracket	-	-

Mounting the Switch in a Rack

Procedure

- Step 1** Use the four supplied Phillips machine screws to attach the brackets to the rack.
- Step 2** Use the black Phillips machine screw to attach the cable guide to the left or right bracket.

Figure 32: Front-Mounting Position

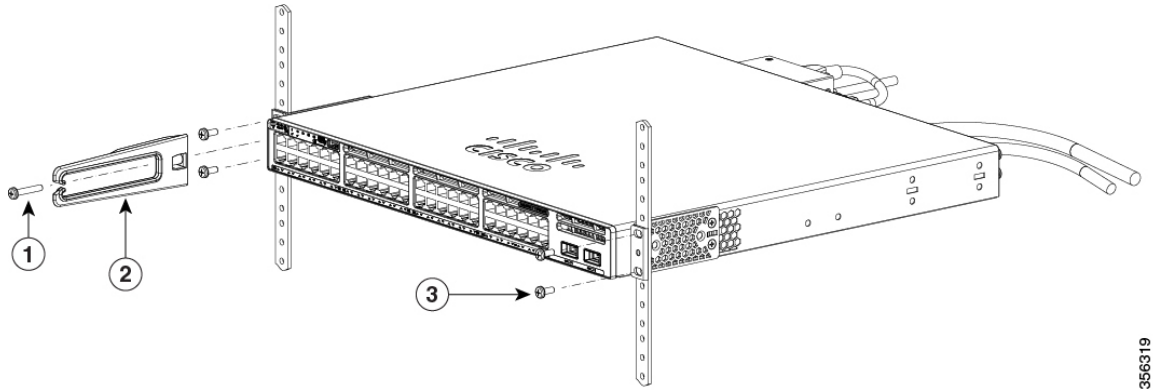

356319

1	Phillips machine screw, black	3	Number-12 or number-10 Phillips machine screws
2	Cable guide	-	-

Figure 33: Mid-Mounting Position

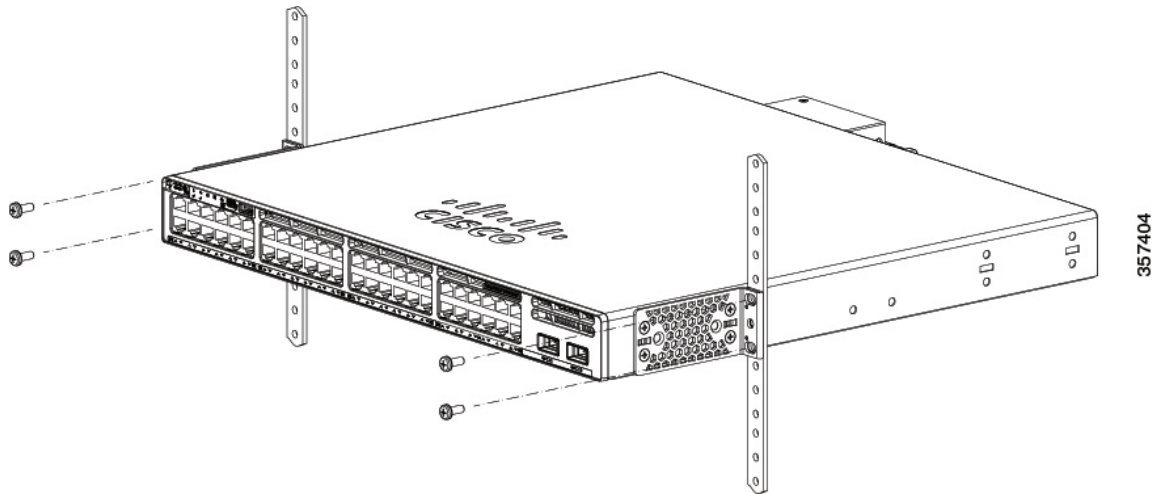

357404

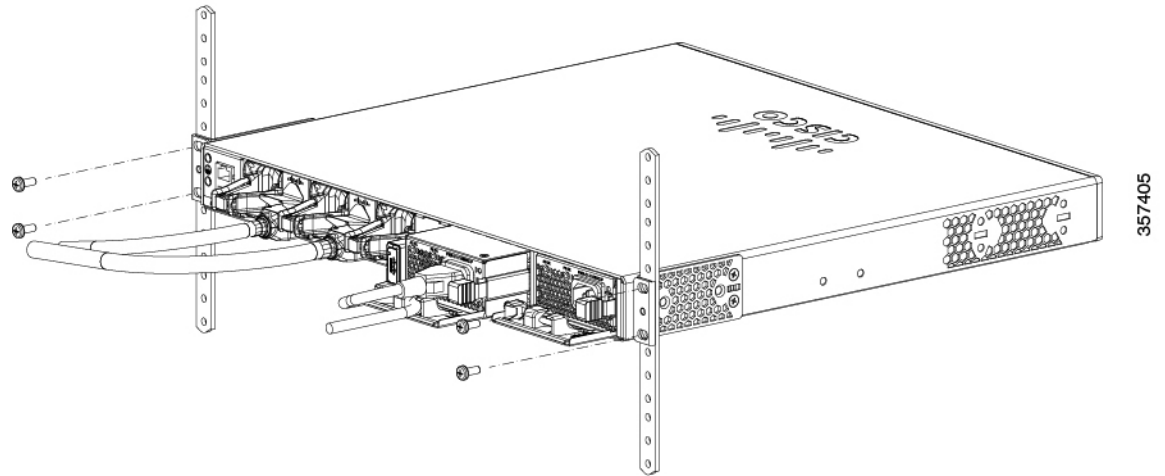
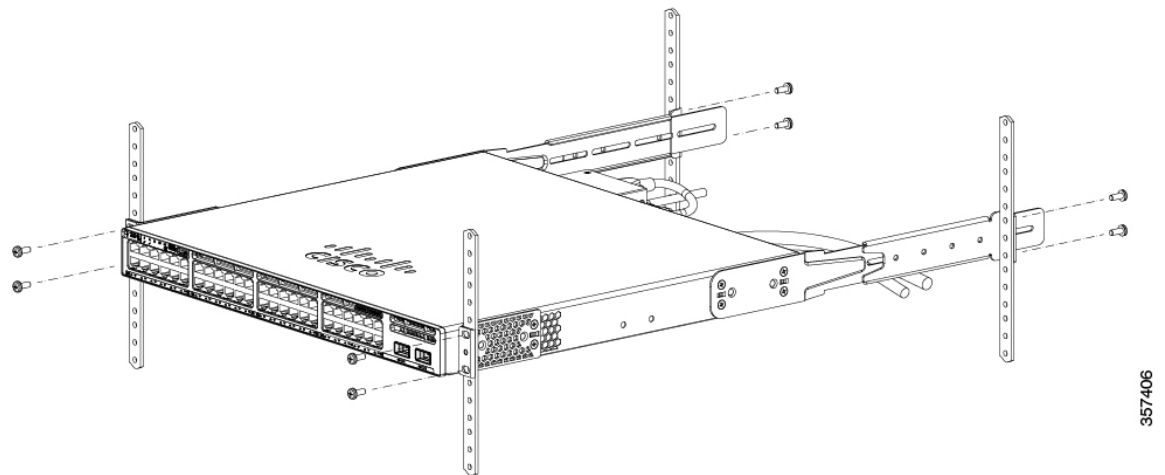
Figure 34: Rear-Mounting Position**Figure 35: Four-Point Mounting Position**

Installing the Switch on a Table or Shelf

Procedure

- Step 1** To install the switch on a table or shelf, locate the adhesive strip with the rubber feet in the mounting-kit envelope.
- Step 2** Attach the four rubber feet to the four circular etches on the bottom of the chassis.
- Step 3** Place the switch on the table or shelf near an AC power source.

- Step 4** When you complete the switch installation, see [After Switch Installation, on page 60](#) for information on switch configuration.
-

After Switch Installation

- Configure the switch using the Web User Interface. For more information, see "Configuring the Switch Using the Web User Interface" topic in the *Software Configuration Guide*.
- Connect the StackPower and StackWise ports.
- Install the power cord retainer (optional).
- Connect the required devices to the switch ports.
- Turn on the power supply switches to power up the system. While powering up, the switch performs a series of bootstrap diagnostic tests.



Note The switch is designed to boot up in less than 30 minutes, provided that the neighboring devices are in fully operational state.

- Verify port connectivity after connecting devices to the switch ports. The LED turns green when the switch and the attached device have a link.

Connecting the StackWise Cables

Before connecting the StackWise cables, review the [Planning a Switch Data Stack, on page 47](#). Always use a Cisco-approved StackWise cable to connect the switches.

Connecting a StackWise-320 Cable

Procedure

- Step 1** Remove the dust covers from the StackWise cables and store them for future use.
- A StackWise adapter must be installed in the StackWise port to enable stacking. In a default setup, the StackWise adapter blanks are installed in the StackWise ports. If StackWise is ordered with the switch, StackWise adapters are already installed in the StackWise ports, and you can proceed to step 4.
- Step 2** Remove the StackWise adapter blanks from each destination StackWise port using the Torx T15 Allen key provided in the stacking kit (or a Torx T15 screwdriver). Store them for future use.
- Step 3** Install the StackWise adapter in each destination StackWise port, and secure it in place using the supplied Torx T15 key, or a Torx T15 screwdriver.

Figure 36: Inserting the StackWise-320 Adapter

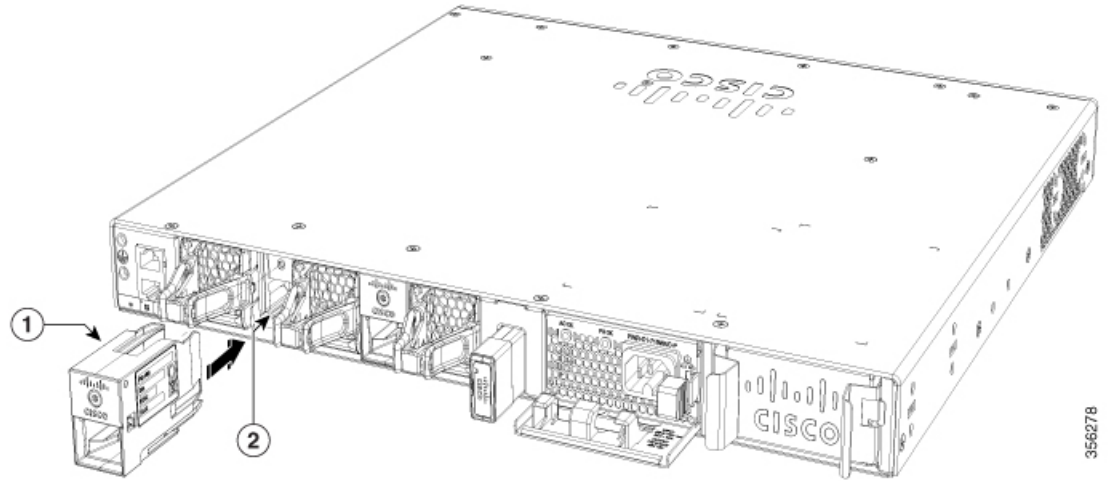

356278

1	StackWise-320 adapter	2	StackWise port
---	-----------------------	---	----------------

Step 4 Align and insert the StackWise cable connector into the StackWise adapter in the StackWise port. Push inwards until the spring latch locks into the slot.

Figure 37: Installing the StackWise-320 Cable in a StackWise Port

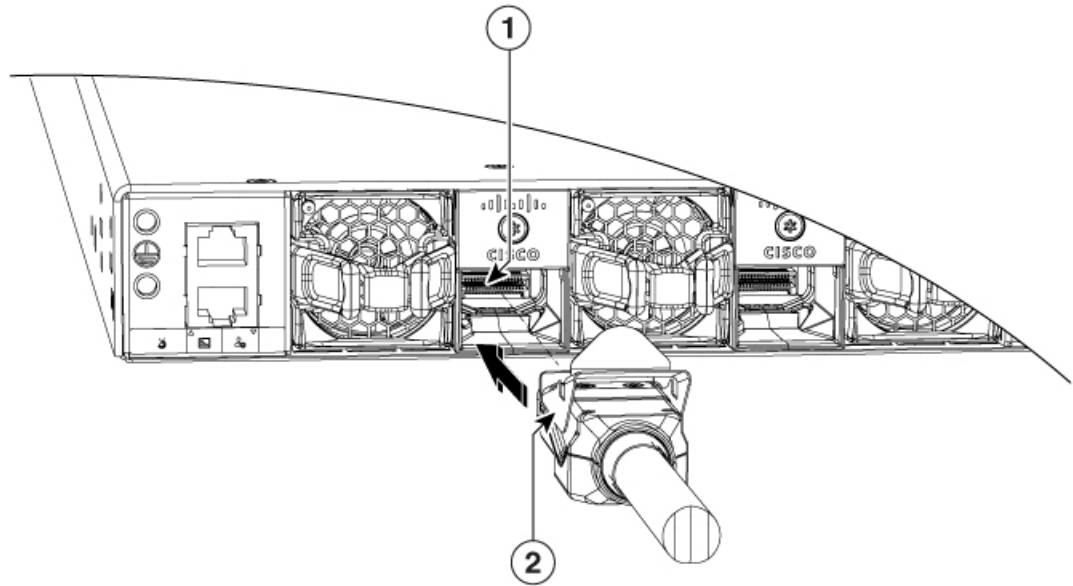

356272

1	StackWise-320 adapter	2	Stacking cable
---	-----------------------	---	----------------

To remove a StackWise-320 adapter from the connector, make sure you press down the spring latch to unlock it from the slot.

Removing and installing the StackWise cable can shorten its useful life. Do not remove and insert the cable more often than is absolutely necessary (installing and removing it up to 200 times is supported).

- Step 5** Connect the other end of the cable to the StackWise port on the other switch.
-

Connecting a StackWise-480/1T Cable

Procedure

- Step 1** Remove the dust covers from the StackWise cables and store them for future use.
- Step 2** Connect the cable to the StackWise port on the switch rear panel. Align the connector and connect the StackWise cable to the StackWise port on the switch rear panel and finger-tighten the screws (clockwise direction). Make sure the Cisco logo is on the top side of the connector as shown in the figure.

Figure 38: Connecting the StackWise-480/1T Cable in a StackWise Port

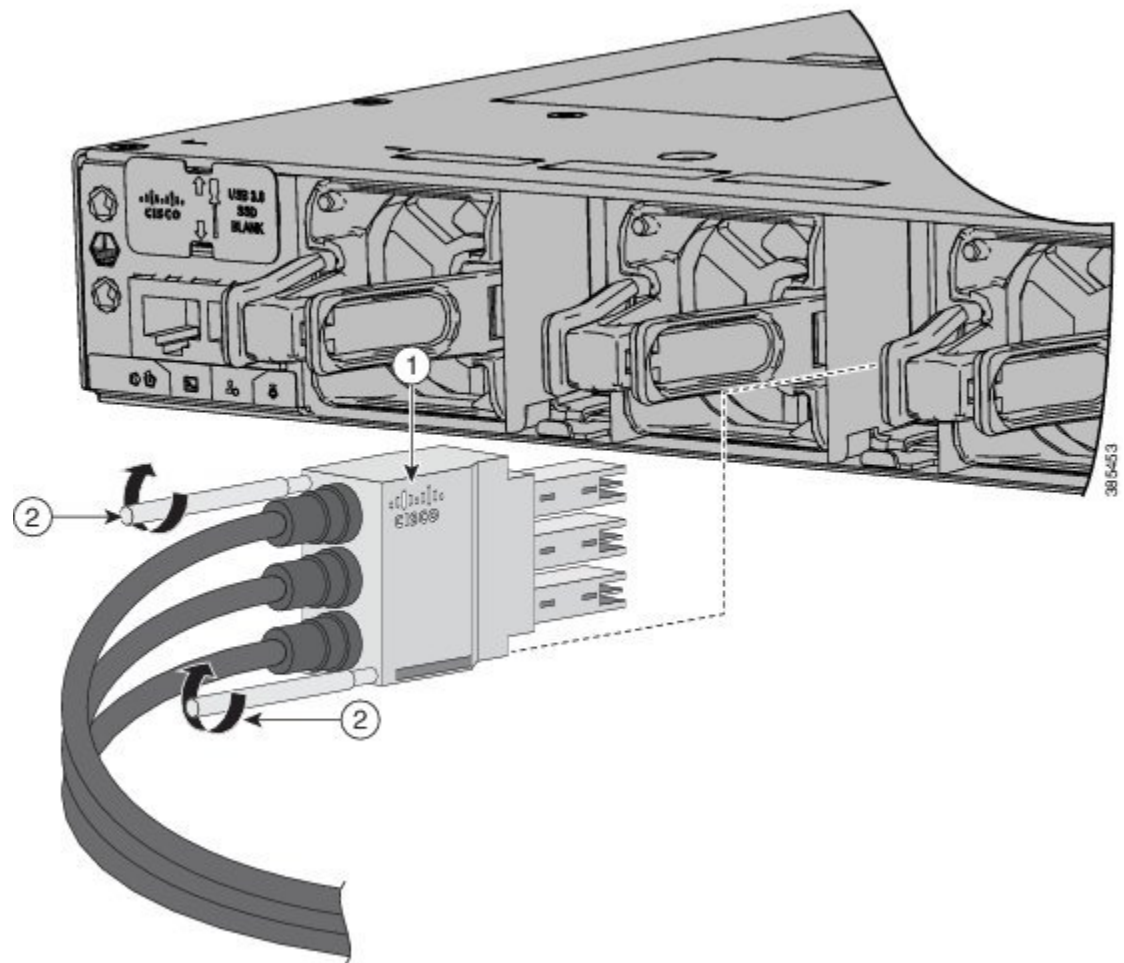

1	Cisco logo	2	Connector screws
---	------------	---	------------------

Step 3 Connect the other end of the cable to the port on the other switch and finger-tighten the screws. Avoid overtightening the screws.

To remove the StackWise-480/1T cable from the connector, make sure you fully unscrew the correct screws. When the connectors are not being used, replace the dust covers.

Caution Removing and installing the StackWise cable can shorten its useful life. Do not remove and insert the cable more often than is absolutely necessary (installing and removing it up to 200 times is supported).

Connecting to the StackPower Ports

Before you begin

Before connecting the StackPower cables, review [Planning a Switch Data Stack, on page 47](#). Always use a Cisco-approved StackPower cable to connect the switches. To prevent misconfiguration, the StackPower ports on the switch are keyed and have colored bands that match the keying and bands on the StackPower cable connectors.

Procedure

- Step 1** Remove the dust covers from the StackPower cable connectors.
- Step 2** Connect the end of the cable with a green band to either StackPower port on the first switch. Align the connector correctly, and insert it into a StackPower port on the switch rear panel.
- Step 3** Connect the end of the cable with the yellow band to another switch (to configure StackPower power sharing).
- Step 4** Hand-tighten the captive screws to secure the StackPower cable connectors in place.

Caution Removing and installing the StackPower cable can shorten its useful life. Do not remove and insert the cable more often than is absolutely necessary.

Installing a Network Module in the Switch

For information on network modules, see:

- [Installing a Network Module, on page 68](#)

Installing and Removing Cisco Pluggable Transceiver Modules

See these sections for information on Cisco pluggable transceiver modules (SFP, SFP, SFP28 and QSFP+ modules):

- [Installing a Cisco Pluggable Transceiver Module, on page 77](#)
- [Removing Cisco Pluggable Transceiver Modules, on page 78](#)
- [Cisco 40-Gigabit QSFP+ Transceiver Modules Installation Note](#)

Connecting Devices to the Ethernet Ports

- [10/100/1000/Multigigabit Ethernet Port Connections, on page 65](#)
- [PoE+ and Cisco UPOE/UPOE+ Port Connections, on page 65](#)

10/100/1000/Multigigabit Ethernet Port Connections

The switch 10/100/1000 and Multigigabit Ethernet port configuration changes to operate at the speed of the attached device. If the attached ports do not support autonegotiation, you can manually set the speed and duplex parameters. Connecting devices that do not autonegotiate or that have the speed and duplex parameters manually set can reduce performance or result in no linkage.

To maximize performance, choose one of these methods for configuring the Ethernet ports:

- Let the ports autonegotiate both speed and duplex.
- Set the interface speed and duplex parameters on both ends of the connection.

Auto-MDIX Connections

The autonegotiation and the auto-MDIX features are enabled by default on the switch.

With autonegotiation, the switch port configurations change to operate at the speed of the attached device. If the attached device does not support autonegotiation, you can manually set the switch interface speed and duplex parameters.

With auto-MDIX, the switch detects the required cable type for copper Ethernet connections and configures the interface accordingly.

If auto-MDIX is disabled, use the guidelines in this table to select the correct cable.

Table 21: Recommended Ethernet Cables (When Auto-MDIX is Disabled)

Device	Crossover Cable	Straight-Through Cable
Switch to switch	Yes	No
Switch to hub	Yes	No
Switch to computer or server	No	Yes
Switch to router	No	Yes
Switch to IP phone	No	Yes

³ 100BASE-TX and 1000BASE-T traffic requires twisted four-pair, Category 5 or higher. 10BASE-T traffic can use Category 3 cable or higher.

PoE+ and Cisco UPOE/UPOE+ Port Connections

The 10/100/1000/Multigigabit Ethernet PoE+ and Cisco UPOE/UPOE+ ports have the same autonegotiation settings and cabling requirements that are described in the [10/100/1000/Multigigabit Ethernet Port Connections, on page 65](#). These ports can provide PoE, PoE+, or Cisco UPOE/UPOE+ inline power.

PoE inline power supports devices compliant with the IEEE 802.3af standard, as well as prestandard Cisco IP Phones and Cisco Aironet Access Points. Each port can deliver up to 15.4 W of PoE. PoE+ inline power supports devices compliant with the IEEE 802.3at standard, by delivering up to 30 W of PoE+ power per port to all switch ports.

Cisco UPOE+/UPOE uses the same cabling standard as PoE. However, instead of transmitting power over two of the twisted pairs, it provides the capability to source up to 90 W of power by using all four twisted pairs of standard Ethernet cabling (Category 5e or higher). To achieve this, it uses two Power Sourcing Equipment (PSE) controllers to power both the signal pairs and the spare pairs. Cisco UPOE+ guarantees 71.3 W of power to a class 8 Powered Device (PD). The following figure shows the architectural difference between PoE/PoE+ and Cisco UPOE/UPOE+.

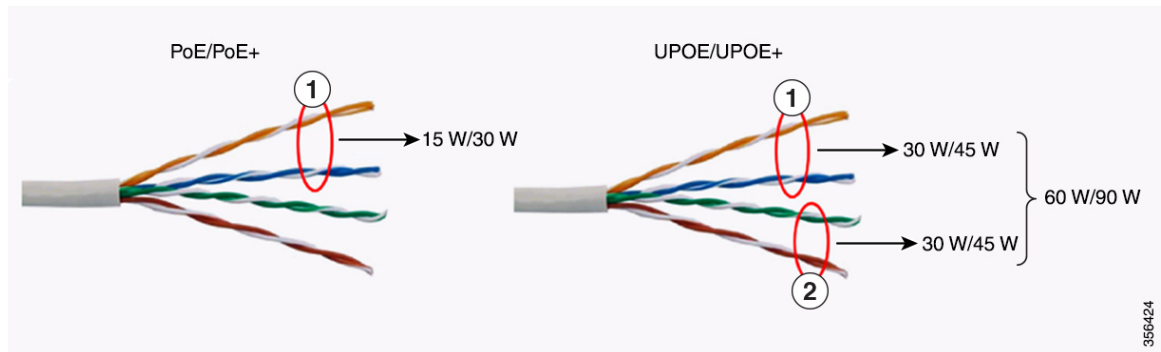

Table 22: PoE/PoE+ and Cisco UPOE/UPOE+ Differences

1	Signal pair	2	Spare pair
---	-------------	---	------------

See [Power Supply Modules](#), on page 25 for the power supply modules required to support PoE, PoE+, and Cisco UPOE/UPOE+ on 24- and 48-port switches.



Warning Voltages that present a shock hazard may exist on Power over Ethernet (PoE) circuits if interconnections are made using uninsulated exposed metal contacts, conductors, or terminals. Avoid using such interconnection methods, unless the exposed metal parts are located within a restricted access location and users and service people who are authorized within the restricted access location are made aware of the hazard. A restricted access area can be accessed only through the use of a special tool, lock and key or other means of security. Statement 1072



Warning Voice over IP (VoIP) service and the emergency calling service do not function if power fails or is disrupted. After power is restored, you might have to reset or reconfigure equipment to regain access to VoIP and the emergency calling service. In the USA, this emergency number is 911. You need to be aware of the emergency number in your country. Statement 371



Caution Ethernet twisted pair cables can store high levels of static electricity. Always ground the cables to a suitable and safe earth ground before connecting them to the switch or other devices.



Caution Noncompliant cabling or powered devices can cause a PoE port fault. Use only standard-compliant cabling to connect Cisco prestandard IP Phones and wireless access points, IEEE 802.3af, 802.3at (PoE+), or 802.3bt (UPOE/UPOE+)-compliant devices. You must remove any cable or device that causes a PoE fault.



CHAPTER 4

Installing a Network Module

- [Network Modules Overview, on page 67](#)
- [Installing a Network Module in the Switch, on page 68](#)
- [Removing a Network Module, on page 76](#)
- [Installing and Removing Cisco Transceiver Modules, on page 77](#)
- [Finding the Network Module Serial Number, on page 79](#)

Network Modules Overview

The Cisco Catalyst 9300 Series Switches support the following optional network modules for uplink ports.

Network Module	Description
C9300 Network Modules	
C9300-NM-4G ^{1, on page 68}	This module has four 1 GE SFP module slots. Any combination of standard SFP modules are supported.
C9300-NM-4M ^{1, on page 68}	This module has four Multigigabit Ethernet (mGig) interfaces.
C9300-NM-2Q ^{1, on page 68}	This module has two 40 GE QSFP+ module slots.
C9300-NM-8X ^{1, on page 68}	This module has eight 10 GE SFP+ module slots.
C9300-NM-2Y ^{1, on page 68}	This module has two 25 GE SFP28 module slots.
C9300-NM-BLANK	This is a blank module.
C9300X Network Modules	
C9300X-NM-2C ^{2, on page 68}	This module has two 40 GE/100 GE slots with a QSFP+ connector in each slot.
C9300X-NM-4C ³	This module has four 40 GE/100 GE slots with a QSFP+ connector in each slot.

Network Module	Description
C9300X-NM-8M ³	This module has eight Multigigabit Ethernet (mGig) module slots.
C9300X-NM-8Y ^{2, on page 68}	This module has eight 25 GE/10 GE/1 GE slots with an SFP28 port in each slot.
C9300X-NM-BLANK	This is a blank module.



- Note**
1. Supported only on Cisco Catalyst 9300 Series Switches.
 2. Supported only on Cisco Catalyst 9300X Series Switches.
 3. Supported only on C9300X-24Y.

Installing a Network Module in the Switch

Safety Warnings

This section includes the installation cautions and warnings. Translations of the safety warnings are available in the *Regulatory Compliance and Safety Information for Cisco Catalyst 9300 Series Switches*.

Read this section before you install a network module.



Caution Proper ESD protection is required whenever you handle equipment. Installation and maintenance personnel should be properly grounded by grounding straps to eliminate the risk of ESD damage to the equipment. Equipment is subject to ESD damage whenever you remove it.



Warning Only trained and qualified personnel should be allowed to install, replace, or service this equipment. Statement 1030



Warning Do not reach into a vacant slot or chassis while you install or remove a module. Exposed circuitry could constitute an energy hazard. Statement 206

Installing a Network Module



Note The switch can operate without a network module, but a blank module (with no ports or SFP slots) is available and should be installed when uplink ports are not required.



Note The switch generates logs when you insert or remove a network module with SFP/SFP+/SFP28/QSFP+ slots.

Use only supported network modules and Cisco pluggable transceivers. Each module has an internal serial EEPROM that is encoded with security information.

The network module is hot-swappable. If you remove a module, replace it with another network module or a blank module.



Note The switch complies with EMC, safety, and thermal specifications when a network module is present. If no uplink ports are required, install a blank network module.

Before you begin

When installing network modules, observe these precautions:

- Do not remove the blank module from the slot unless you are installing a network module. A module must be in the uplink slot at all times.
- Do not remove the dust plugs from the pluggable transceivers or the rubber caps from the fiber-optic cable until you connect the cable. The plugs and caps protect the module ports and cables from contamination and ambient light.
- Removing and installing a network module can shorten its useful life. Do not remove and insert a network module more often than is necessary.
- To prevent ESD damage, follow your normal board and component handling procedures when connecting cables to the switch and other devices.



Note Unlike other network modules, the C9300-NM-8X cannot be fully inserted and secured until the jackscrew is properly tightened.

1. Push the module into the uplink slot until the jackscrew connects with the rightmost tab.
 2. You will feel some light resistance, because a spring-loaded tab inside the slot will push back against the C9300-NM-8X module
 3. Continue to tighten the jackscrew while gently pushing the front panel of the network module into the slot.
-

Procedure

-
- Step 1** Attach an ESD-preventive wrist strap to your wrist and to an earth ground surface.
- Step 2** Remove the module from the protective packaging.
- Step 3** Remove the blank module from the switch and save it.

Figure 39: Removing the Blank Module

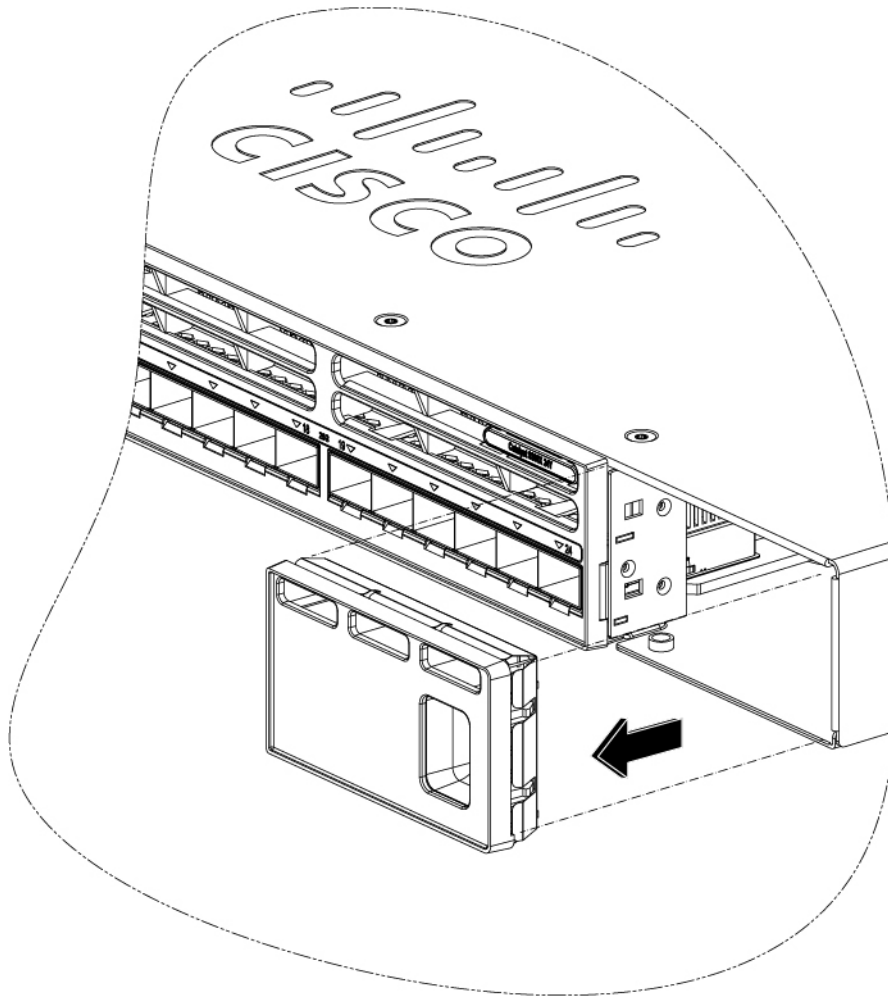

357395

Caution Verify the correct orientation of your module before installing it. Incorrect installation can damage the module.

Caution Do not install the network module with connected cables or installed pluggable transceivers. Always remove any cables and transceiver modules before you install the network module.

Caution A module interface might become error-disabled when a network module with connected fiber-optic cables is installed or removed. If an interface is error-disabled, you can reenble the interface by using the **shutdown** and **no shutdown** interface configuration commands.

Step 4 Position the module face up to install it in the module slot. Slide the module into the slot until the screw makes contact with the chassis. Fasten the captive screws to secure the network module in place.

Figure 40: Installing the Network Module in the Switch

Step 5 Do one of the following:

- While installing C9300 network modules, position the module face up to install it in the module slot. Slide the module into the slot until the screw makes contact with the chassis. Fasten the captive screws to secure the network module in place.

Figure 41: Installing the C9300 Network Module in the Switch

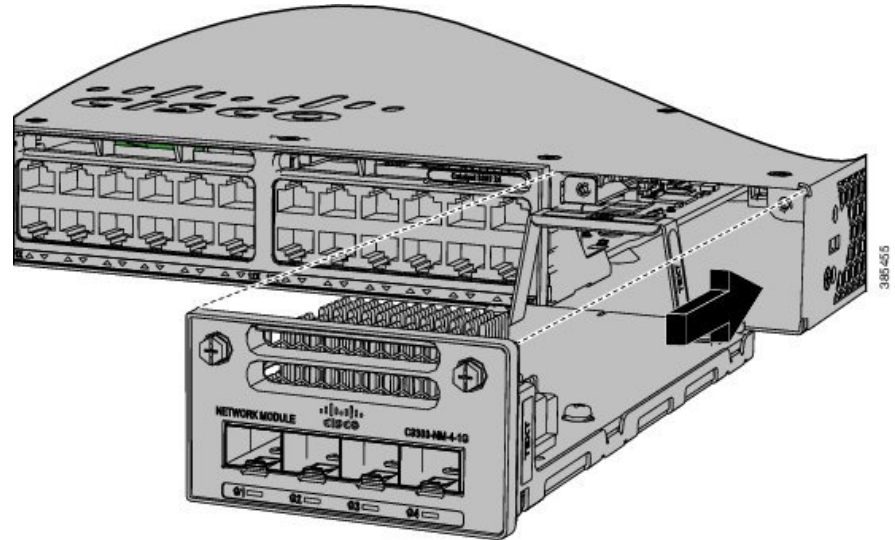

- While installing C9300X network modules, position the module face up to install it in the module slot. Slide the module into the slot until the back of the module faceplate is flush with the switch faceplate. Secure the network module in place by the ejector and the latch.

Figure 42: Installing the C9300X Network Module in the Switch

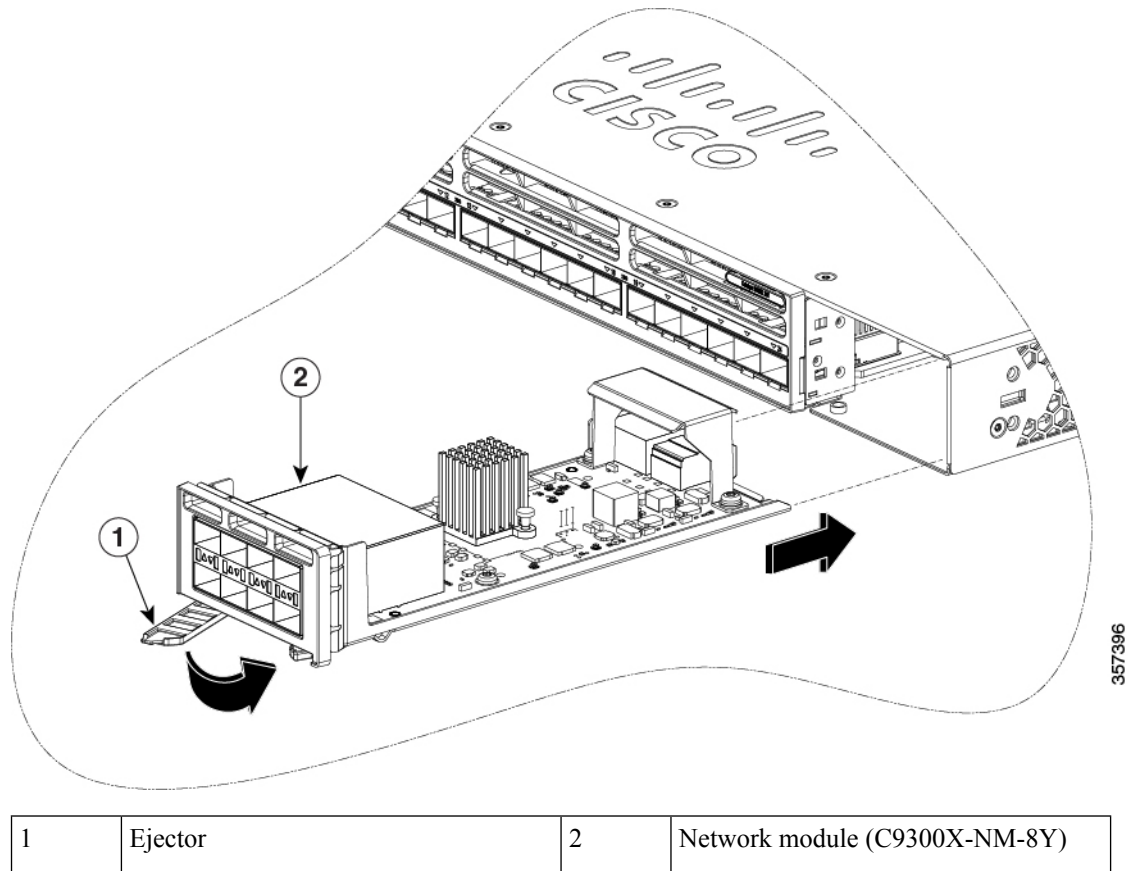

357396

Network Module Port Configurations

C9300-NM-2Q Module

If you use a 40G QSFP module, the ports default to 40G interfaces. In this case, the 10G interfaces are displayed but not used.

Table 23: C9300-NM-2Q Module with 40G QSFP Module

Interface	Action
FortyGigabitEthernet1/1/1	Configure this interface
FortyGigabitEthernet1/1/2	Configure this interface
TenGigabitEthernet1/1/1	Disregard
TenGigabitEthernet1/1/2	Disregard
TenGigabitEthernet1/1/3	Disregard

Interface	Action
TenGigabitEthernet1/1/4	Disregard
TenGigabitEthernet1/1/5	Disregard
TenGigabitEthernet1/1/6	Disregard
TenGigabitEthernet1/1/7	Disregard
TenGigabitEthernet1/1/8	Disregard

C9300-NM-4G Module

All ports in the C9300-NM-4G module are natively GigabitEthernet and are configured GigabitEthernet1/1/1 through GigabitEthernet1/1/4. There are only four interfaces that are valid, and the other four should not be used even though they are available in the CLI.

Table 24: C9300-NM-4G Module

Interface	Action
GigabitEthernet1/1/1	Configure this interface
GigabitEthernet1/1/2	Configure this interface
GigabitEthernet1/1/3	Configure this interface
GigabitEthernet1/1/4	Configure this interface
TenGigabitEthernet1/1/1	Disregard
TenGigabitEthernet1/1/2	Disregard
TenGigabitEthernet1/1/3	Disregard
TenGigabitEthernet1/1/4	Disregard

C9300-NM-4M Module

Table 25: C9300-NM-4M Module with 4 Multigigabit Ethernet (mGig) Module

Interface	Action
TenGigabitEthernet1/1/1	Configure this interface
TenGigabitEthernet1/1/2	Configure this interface
TenGigabitEthernet1/1/3	Configure this interface
TenGigabitEthernet1/1/4	Configure this interface

C9300-NM-2Y Module

Table 26: C9300-NM-2Y Module with 25G SFP28 Module

Interface	Action
TwentyFiveGigabitEthernet1/1/1	Configure this interface
TwentyFiveGigabitEthernet1/1/2	Configure this interface

C9300-NM-8X Module

All ports in the C9300-NM-8X module default to 10 G and should be configured as TenGigabitEthernet1/1/1 through TenGigabitEthernet1/1/8, even when you are operating them as 1 G using SFP.

Table 27: C9300-NM-8-10X Module

Interface	Action
TenGigabitEthernet1/1/1	Configure this interface
TenGigabitEthernet1/1/2	Configure this interface
TenGigabitEthernet1/1/3	Configure this interface
TenGigabitEthernet1/1/4	Configure this interface
TenGigabitEthernet1/1/5	Configure this interface
TenGigabitEthernet1/1/6	Configure this interface
TenGigabitEthernet1/1/7	Configure this interface
TenGigabitEthernet1/1/8	Configure this interface

C9300X-NM-2C Module

Table 28: C9300X-NM-2C Module

Interface	Action
HundredGigE1/1/1	Configure this interface
HundredGigE1/1/2	Configure this interface

C9300X-NM-4C Module

Table 29: C9300X-NM-4C Module

Interface	Action
HundredGigE1/1/1	Configure this interface
HundredGigE1/1/2	Configure this interface

Interface	Action
HundredGigE1/1/3	Configure this interface
HundredGigE1/1/4	Configure this interface

C9300X-NM-8M Module

Table 30: C9300X-NM-8M Module

Interface	Action
TenGigabitEthernet1/1/1	Configure this interface
TenGigabitEthernet1/1/2	Configure this interface
TenGigabitEthernet1/1/3	Configure this interface
TenGigabitEthernet1/1/4	Configure this interface
TenGigabitEthernet1/1/5	Configure this interface
TenGigabitEthernet1/1/6	Configure this interface
TenGigabitEthernet1/1/7	Configure this interface
TenGigabitEthernet1/1/8	Configure this interface

C9300X-NM-8Y Module

Table 31: C9300X-NM-8Y Module

Interface	Action
TwentyFiveGigE1/1/1	Configure this interface
TwentyFiveGigE1/1/2	Configure this interface
TwentyFiveGigE1/1/3	Configure this interface
TwentyFiveGigE1/1/4	Configure this interface
TwentyFiveGigE1/1/5	Configure this interface
TwentyFiveGigE1/1/6	Configure this interface
TwentyFiveGigE1/1/7	Configure this interface
TwentyFiveGigE1/1/8	Configure this interface

Removing a Network Module



Note The switch complies with EMC, safety, and thermal specifications when a network module is present. If no uplink ports are required, install a blank network module.



Note To avoid authentication failure and non-detection of modules, wait for a minimum of 6-8 seconds between the online insertion and removal (OIR) of network modules.

Procedure

Step 1 Attach an ESD-preventive wrist strap to your wrist and to an earth ground surface

Caution Do not remove the network module with connected cables or installed pluggable transceiver modules. Always remove any cables and modules before you remove the network module.

Caution A module interface might become error-disabled when a network module with connected fiber-optic cables is installed or removed. If an interface is error-disabled, you can reenable the interface by using the **shutdown** and **no shutdown** interface configuration commands.

Step 2 Disconnect the cables from the pluggable transceiver module.

Step 3 Remove the pluggable transceiver module from the network module.

Step 4 Loosen the captive screws that hold the network module in place until it completely disengages from the chassis.

Note The C9300-NM-8X module is secured in the switch by only one jackscrew. This screw also helps to eject the module from its connector interface. Before the module can be removed completely, the screw must be unscrewed completely. When removing the screw, a spring pushes the module out when the screw is completely disengaged. Ensure that you hold the module securely until it is completely removed.

Step 5 Carefully slide the network module out of the slot.

Step 6 Install a replacement network module or a blank module in the slot.

Step 7 Place the module that you removed in an antistatic bag or other protective environment.

Installing and Removing Cisco Transceiver Modules

Installing a Cisco Pluggable Transceiver Module

Before you begin

You must have an installed network module to use the transceiver modules. See the switch release notes on Cisco.com for the list of supported pluggable transceiver modules. Use only supported pluggable transceivers on the switch. For the latest information about supported transceiver modules, refer to the [Cisco Transceiver Modules Compatibility Information](#).

For information about installing, removing, cabling, and troubleshooting pluggable transceiver modules, see the module documentation that shipped with your device.

Observe these precautions:



Warning Class 1 laser product. Statement 1008

- Do not remove the dust plugs from the pluggable transceiver modules or the rubber caps from the fiber-optic cable until you are ready to connect the cable. The plugs and caps protect the module ports and cables from contamination and ambient light.
- Removing and installing a pluggable transceiver module can shorten its useful life. Do not remove and insert any module more often than is necessary.
- To prevent ESD damage, follow your normal board and component handling procedures when connecting cables to the switch and other devices.
- When you insert several pluggable transceiver modules in multiple switch ports, wait for 5 seconds between inserting each module. This will prevent the ports from going into error disabled mode. Similarly, when you remove a pluggable transceiver module from a port, wait for 5 seconds before reinserting it.

Procedure

- Step 1** Attach an ESD-preventive wrist strap to your wrist and to an earth ground surface.
- Step 2** Find the send (TX) and receive (RX) markings that identify the top of the transceiver module. On some modules, the send and receive (TX and RX) markings might be shown by arrows that show the direction of the connection.
- Step 3** If the pluggable transceiver module has a bale-clasp latch, move it to the open, unlocked position.
- Step 4** Align the module in front of the slot opening, and push until you feel the connector snap into place.

Figure 43: Installing a Pluggable Transceiver Module in the Network Module

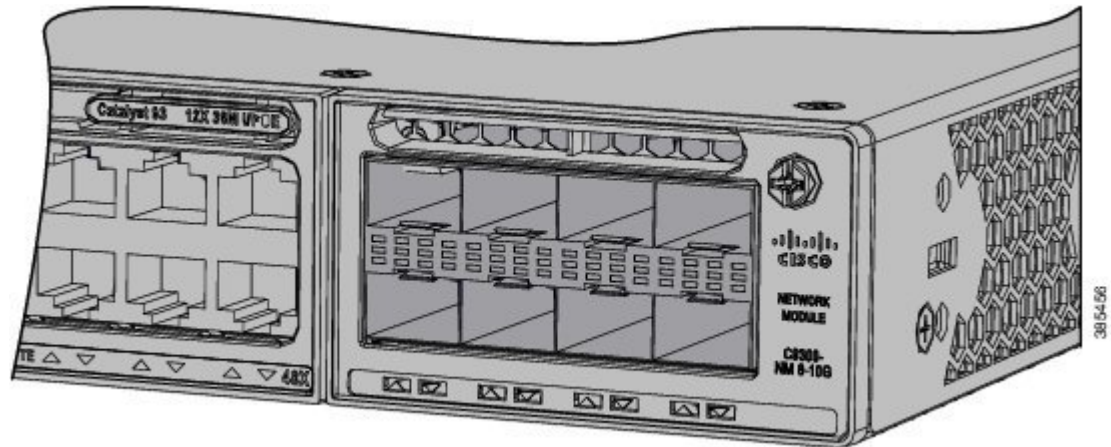

- Step 5** If the module has a bale-clasp latch, close it to lock the module in place.
- Step 6** Remove the dust plugs and save.
- Step 7** Connect the transceiver cables.

Figure 44: Network Module with Pluggable Transceiver Modules Installed

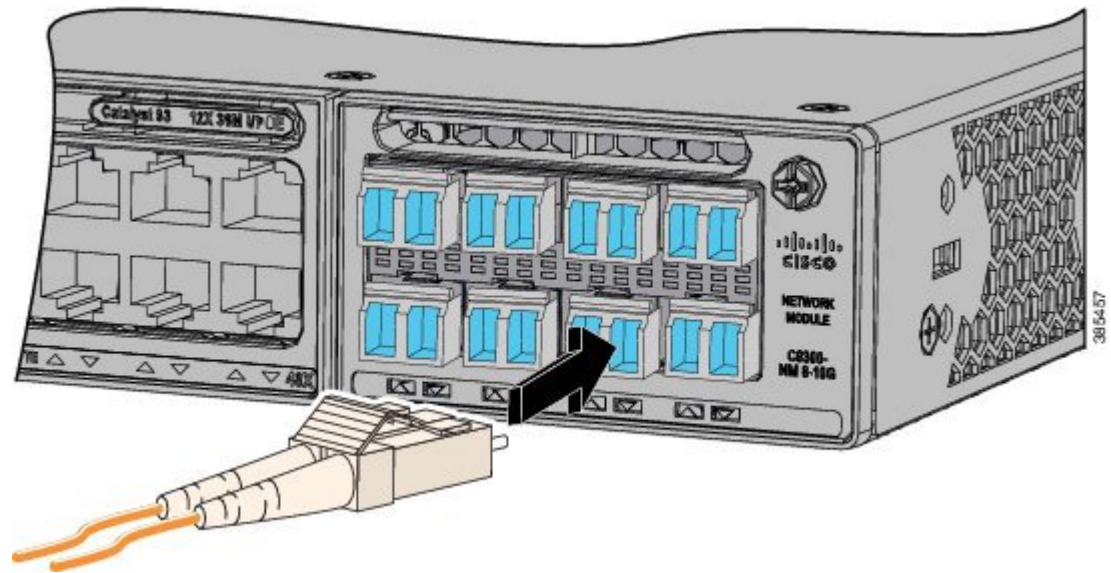

Removing Cisco Pluggable Transceiver Modules

Procedure

- Step 1** Attach an ESD-preventive wrist strap to your wrist and to an earth ground surface.

- Step 2** Disconnect the cable from the transceiver module. For reattachment, note which cable connector plug is send (TX) and which is receive (RX).
- Step 3** Insert a dust plug into the optical ports of the transceiver module to keep the optical interfaces clean.
- Step 4** If the transceiver module has a bale-clasp latch, pull the bale out and down to eject the module. If you cannot use your finger to open the latch, use a small, flat-blade screwdriver or other long, narrow instrument to open it.
- Step 5** Grasp the transceiver module, and carefully remove it from the slot.
- Step 6** Place the transceiver module in an antistatic bag or other protective environment.
-

Finding the Network Module Serial Number

If you contact Cisco Technical Assistance regarding a network module, you need to know its serial number.

Figure 45: Network Module Serial Number Location

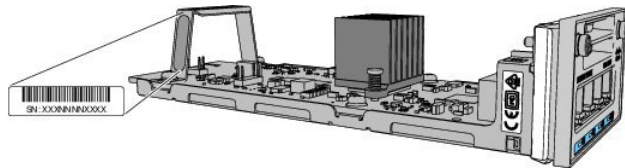



CHAPTER 5

Installing a Power Supply

- [Power Supply Modules Overview, on page 81](#)
- [Installation Guidelines, on page 86](#)
- [Installing or Replacing an AC Power Supply, on page 87](#)
- [Installing a DC Power Supply, on page 89](#)
- [Finding the Power Supply Module Serial Number, on page 94](#)

Power Supply Modules Overview

The switch operates with either one or two active power supply modules. A switch that is part of a StackPower stack operates with power that is supplied by other stack switches. Two power supply modules can be powered up from two different phases.

You can use two AC modules or one module and blank cover. All power supply modules have internal fans. All switches ship with a blank cover in the second power supply slot.

The following table describes the supported internal power supply modules. It lists the Platinum certified power supply modules and the default modules that are shipped with the switch. In a switch, a mix of Platinum certified and non-Platinum certified power supply modules is supported.

Table 32: Power Supply Module Part Numbers and Descriptions

Switch Series	Supported Power Supply Modules	Description
C9300 Series Switches	PWR-C1-350WAC	350 W AC power supply module
	PWR-C1-715WAC	715 W AC power supply module
	PWR-C1-1100WAC	1100 W AC power supply module
	PWR-C1-715WAC-P	715 W AC Platinum certified power supply module
	PWR-C1-1100WAC-P	1100 W AC Platinum certified power supply module
	PWR-C1-1900WAC-P	1900 W AC Platinum certified power supply module
	PWR-C1-715WDC	715 W DC power supply module
C9300L Series Switches	PWR-C1-350WAC	350 W AC power supply module
	PWR-C1-715WAC	715 W AC power supply module
	PWR-C1-715WAC-P	715 W AC Platinum certified power supply module
	PWR-C1-1100WAC-P	1100 W AC Platinum certified power supply module
	PWR-C1-1900WAC-P	1900 W AC Platinum certified power supply module
	PWR-C1-715WDC	715 W DC power supply module
C9300LM Series Switches	PWR-C6-600WAC	600 W AC Platinum certified power supply module
	PWR-C6-1KWAC	1000 W AC Platinum certified power supply module

Switch Series	Supported Power Supply Modules	Description
C9300X Series Switches	PWR-C1-350WAC-P	350 W AC Platinum certified power supply module
	PWR-C1-715WAC-P	715 W AC Platinum certified power supply module
	PWR-C1-1100WAC-P	1100 W AC Platinum certified power supply module
	PWR-C1-1900WAC-P	1900 W AC Platinum certified power supply module



- Note** 1. PWR-C1-1900WAC-P provides 1900 W output power when the nominal input voltage is 230 V. If the nominal input voltage is 115 V, then the output power is limited to 1500 W. See [Table 47: AC Power Cords for PWR-C1-1900WAC-P, on page 119](#) for suitable power cord options.

For more information about power supplies, see [Specifications for the Power Supplies, Switches, and Fan, on page 116](#).

For information on available PoE, PoE+, and Cisco UPOE/UPOE+ requirements, see these sections the [Power Supply Modules, on page 25](#).

The 350 W and 715 W AC power supply modules are autoranging units that support input voltages from 100 through 240 VAC. The 1100W power supply module is an autoranging unit that supports input voltages from 115 through 240 VAC.

Each AC power supply module has a power cord for connection to an AC power outlet. To view the list of available AC power cords, see [AC Power Cord Specifications, on page 118](#).

The following illustrations show the power supply modules.

Figure 46: 1100 W AC Power Supply

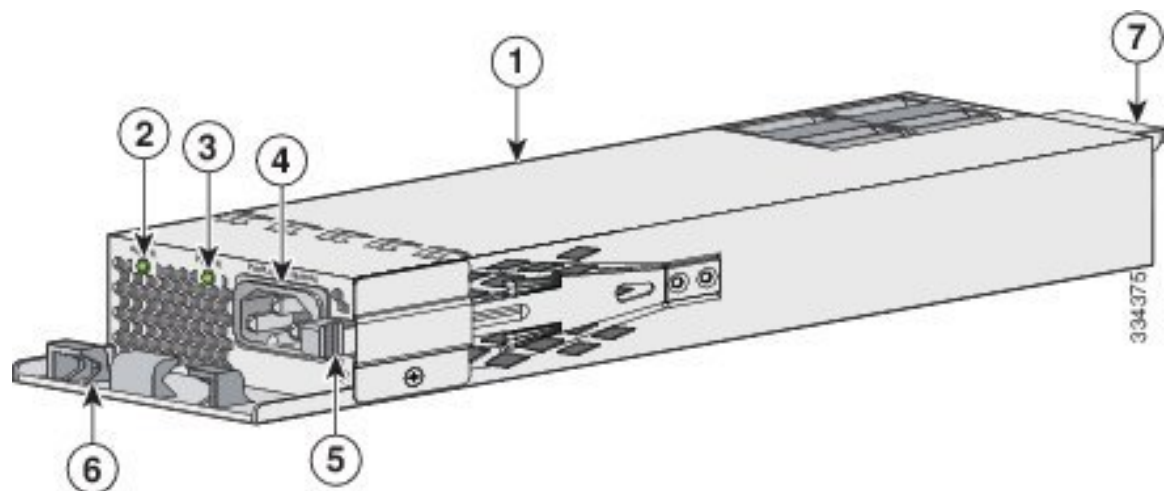

1	1100 W AC power supply module	5	Release latch
2	AC OK LED	6	Power cord retainer
3	PS OK LED	7	Keying feature
4	AC power cord connector	-	-

Figure 47: 1900 W AC Platinum Certified Power Supply

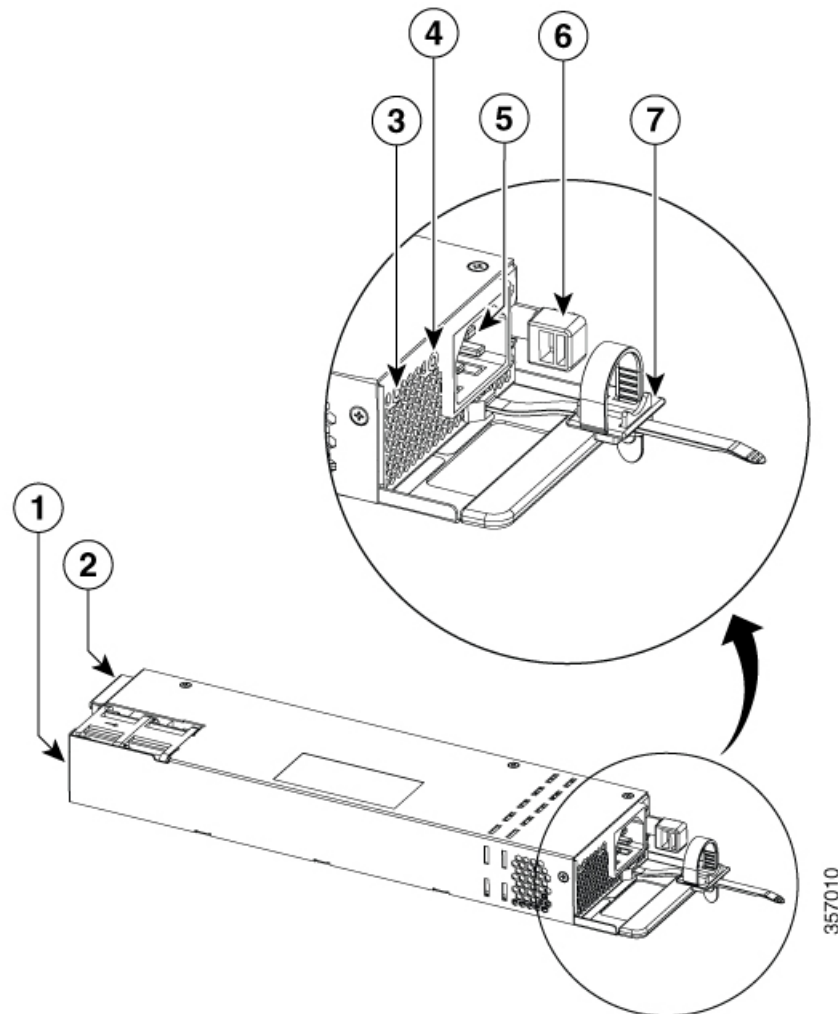

1	1900 W AC power supply module	5	AC power cord connector
2	Keying feature	6	Release latch
3	AC OK LED	7	Power cord retainer
4	PS OK LED		

Figure 48: 715W DC Power Supply (PWR-C1-715WDC)

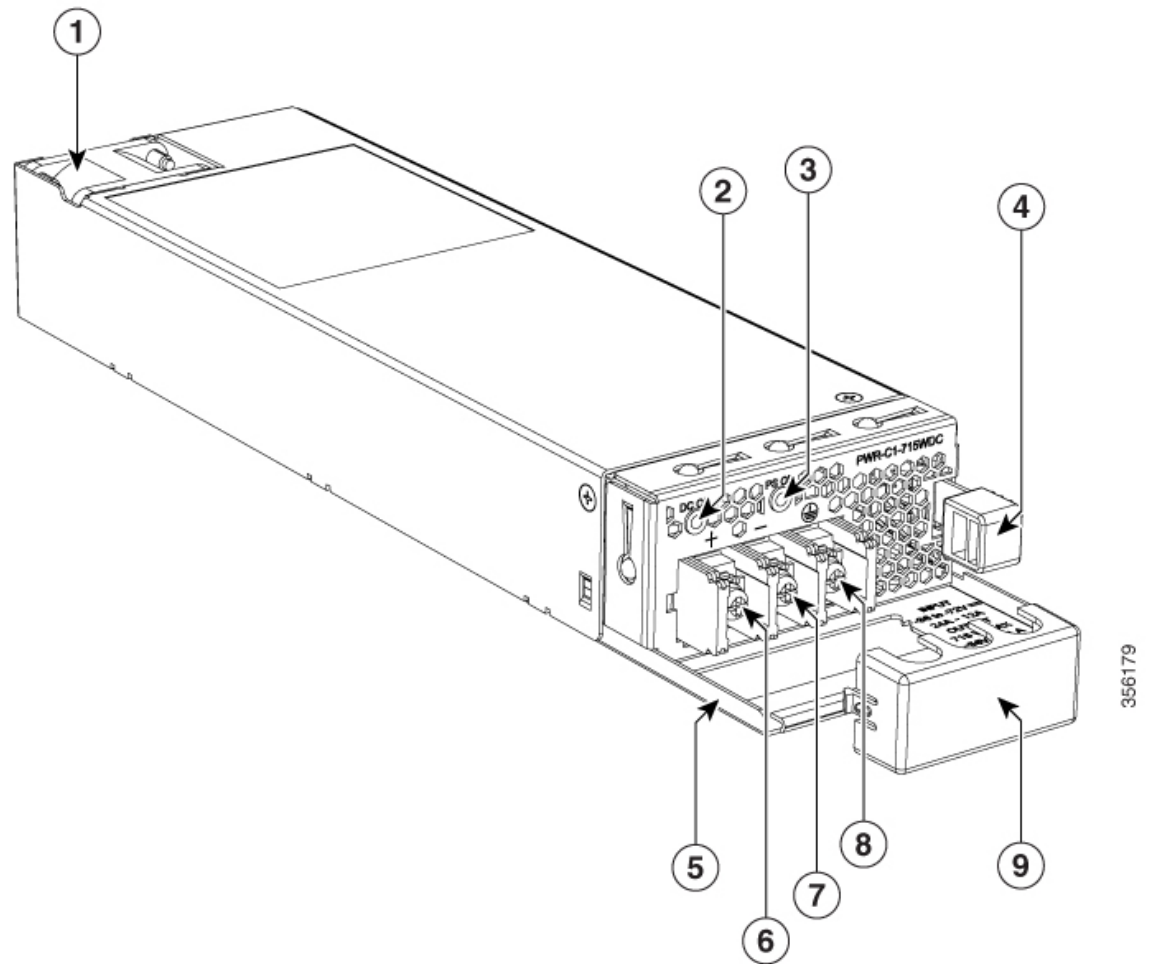

356179

1	715 W DC power supply module	6	Input power terminal (positive polarity)
2	DC OK LED	7	Input power terminal (negative polarity)
3	PS OK LED	8	Grounding terminal
4	Release latch	9	Terminal block safety cover
5	Extraction handle	-	-

If no power supply is installed in a power supply slot, install a power supply slot cover.

Figure 49: Power Supply Slot Cover



1	Release handles	2	Retainer clips
---	-----------------	---	----------------

Table 33: Switch Power Supply Module LEDs

AC or DC OK	Description	PS OK	Description
Off	No AC or DC input power.	Off	Output is disabled, or input is outside operating range (LED is off).
Green	AC or DC input power present.	Green	Power output to switch active.
		Red	Output has failed.

Installation Guidelines

Observe these guidelines when removing or installing a power supply or fan module:

- Do not force the power supply or fan module into the slot. This can damage the pins on the switch if they are not aligned with the module.
- A power supply that is only partially connected to the switch can disrupt the system operation.
- Remove power from the power-supply module before removing or installing the module.
- The power supply is hot-swappable. In some configurations, such as full PoE+ or power sharing mode, removing a power supply causes powered devices to shut down until the power budget matches the input power of a single power supply. To minimize network interruption, hot swap the power supply under these circumstances:
 - The switch is in StackPower mode and sufficient power is available.
 - The switch is powered by other switches in a power stack, and no active backup is in progress.

For the switch commands that display available power budget, see the software configuration guide.



Caution Do not operate the switch with one power-supply module slot empty. For proper chassis cooling, both module slots must be populated, with either a power supply or a blank module.



Warning This equipment must be grounded. Never defeat the ground conductor or operate the equipment in the absence of a suitably installed ground conductor. Contact the appropriate electrical inspection authority or an electrician if you are uncertain that suitable grounding is available.

Statement 1024



Warning Blank faceplates and cover panels serve three important functions: they prevent exposure to hazardous voltages and currents inside the chassis; they contain electromagnetic interference (EMI) that might disrupt other equipment; and they direct the flow of cooling air through the chassis. Do not operate the system unless all cards, faceplates, front covers, and rear covers are in place.

Statement 1029



Warning Do not reach into a vacant slot or chassis while you install or remove a module. Exposed circuitry could constitute an energy hazard.

Statement 206



Warning Only trained and qualified personnel should be allowed to install, replace, or service this equipment.

Statement 1030



Warning If a Cisco external power system is not connected to the switch, install the provided connector cover on the back of the switch.

Statement 386

Installing or Replacing an AC Power Supply

Procedure

- Step 1** Turn off the power at its source.
- Step 2** Remove the power cord from the power cord retainer.
- Step 3** Remove the power cord from the power connector.

Step 4 Press the release latch at the right side of the power supply module inward and slide the power supply out.

Caution Do not leave the power-supply slot open for more than 90 seconds while the switch is operating.

Warning This unit might have more than one power supply connection. All connections must be removed to de-energize the unit. **Statement 1028**

Step 5 Insert the new power supply into the power supply slot, and gently push it into the slot. When correctly inserted, the 350 W and 715 W power supplies (excluding the power cord retainer) are flush with the switch rear panel. The 1100 W power supply modules extend 1.5 inches and 1900 W power supply modules extend 1.5 inches from the switch rear panel.

Figure 50: Inserting the AC Power Supply in the Switch

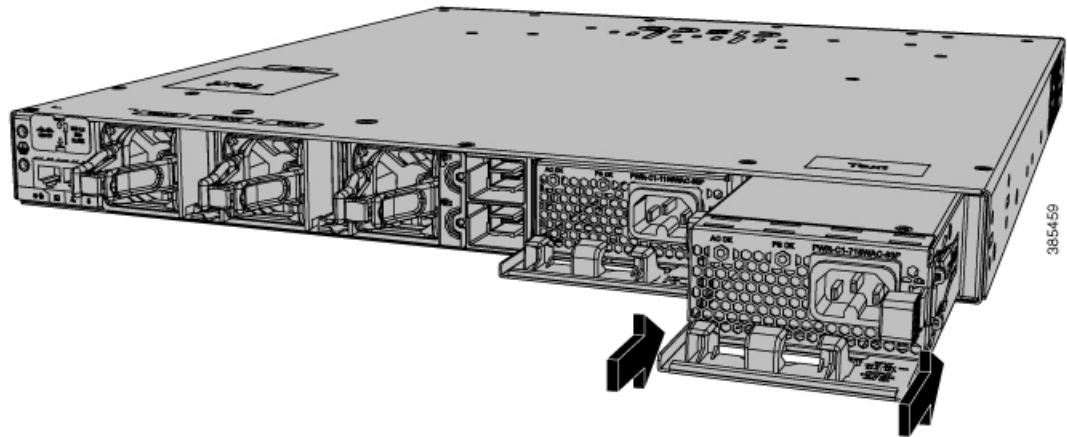

Step 6 (Optional) Make a loop in the power cord and thread it through the power cord retainer or use the cable-tie retainer clip on the 1900 W supply.

Figure 51: AC-Power Supply with Power Cord Retainer

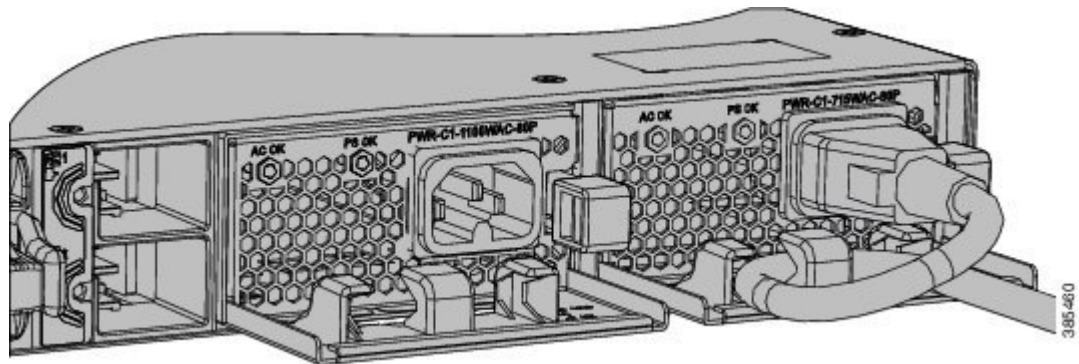

Step 7 Connect the power cord to the power supply and to an AC power outlet. Turn on the power at the power source.

Step 8 Confirm that the power supply AC OK and PS OK LEDs are green.

Installing a DC Power Supply



Warning An exposed wire lead from a DC-input power source can conduct harmful levels of electricity. Be sure that no exposed portion of the DC-input power source wire extends from the terminal block plug. Statement 122



Warning Before performing any of the following procedures, ensure that power is removed from the DC circuit. Statement 1003



Warning This product relies on the building's installation for short-circuit (overcurrent) protection. Ensure that the protective device is rated not greater than: 20 A. Statement 1005



Warning A readily accessible two-poled disconnect device must be incorporated in the fixed wiring. Statement 1022



Warning Hazardous voltage or energy may be present on power terminals. Always replace cover when terminals are not in service. Be sure uninsulated conductors are not accessible when cover is in place. Statement 1086



Note The grounding architecture of this product is DC-isolated (DC-I).

Equipment That You Need

- Ratcheting torque screwdriver with a number-2 Phillips head that exerts up to 15 pound-force inches (lbf-in.) of pressure.
- Panduit crimping tool with optional controlled-cycle mechanism (model CT-720, CT-920, CT-920CH, CT-930, or CT-940CH).
- Wire-stripping tools.
- 12-gauge copper ground wire (insulated or not) for the single-hole ground connection.
- 8-gauge copper ground wire (insulated or not) for the dual-hole ground connection.
- Dual-hole ground lug and two screws (included in the DC power supply accessory kit) and single-hole ground lug and screw (included in the switch accessory kit). The dual-hole lug is required for the grounding of the switch in NEBS installations where the DC supply is the only NEBS compliant power supply option.
- Four leads of 14-gauge copper wire.

- Four fork-type terminals from the DC power supply accessory kit. The terminals must be the proper size for M3 screws in a Dinkle DT-35-B25-style terminal block.
- M5 screws for 12 AWG wire connection for NEBS installations.

Grounding the Switch

Follow these steps to install either a single-hole ground lug or a dual-hole ground lug on the switch. Make sure to follow any grounding requirements at your site.

Before you begin

Follow the grounding procedures at your site and observe these warnings:



Warning This equipment must be grounded. Never defeat the ground conductor or operate the equipment in the absence of a suitably installed ground conductor. Contact the appropriate electrical inspection authority or an electrician if you are uncertain that suitable grounding is available. Statement 1024



Warning When installing or replacing the unit, the ground connection must always be made first and disconnected last. Statement 1046



Caution Follow the grounding procedure instructions, and use a UL-listed lug (included in the accessory kit).



Caution To comply with the Telcordia GR-1089 NEBS standard for electromagnetic compatibility and safety, connect the (Management Ethernet) ports only to intra-building or unexposed wiring or cable. The intrabuilding cable must be shielded and the shield must be grounded at both ends. The intra-building port(s) of the equipment or subassembly must not be metallicly connected to interfaces that connect to the OSP or its wiring. These interfaces are designed for use as intra-building interfaces only (Type 2 or Type 4 ports as described in GR-1089-CORE) and require isolation from the exposed OSP cabling. The addition of Primary Protectors is not sufficient protection in order to connect these interfaces metallicly to OSP wiring.

Procedure

- Step 1** Use the ground lug screw and the lug ring for single-ground connections. Use the dual-hole lug for ground connections for NEBS installation.
- Step 2** Strip the 12-gauge or 8-gauge ground wire to 0.5 inch (12.7 mm) ± 0.02 inch (0.5 mm). Stripping more than the recommended amount of wire can leave exposed wire from the connector. Use 12-gauge copper ground wire for the single-ground connection. Use 8-gauge copper ground wire for the dual-ground connection.

Figure 52: Stripping the Ground Wire

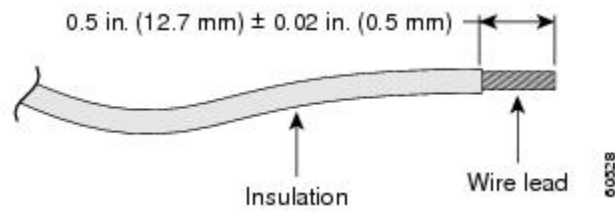

Step 3 Slide the open end of the ground lug over the exposed area of the wire.

Step 4 Using a Panduit crimping tool, crimp the ground lug to the wire.

Figure 53: Crimping the Ground Lug

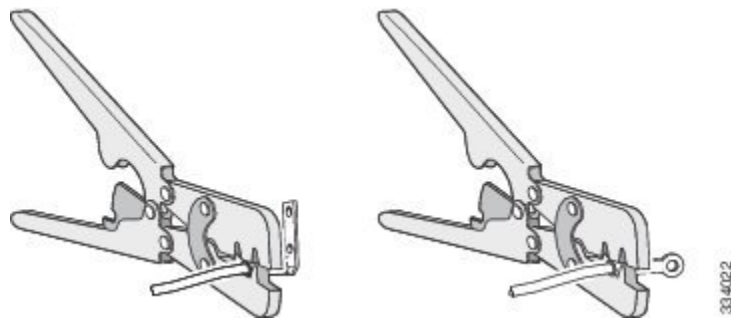

Step 5 Use the ground screw to attach the single-hole ground lug to the switch rear panel. Use two ground screws to attach the dual-hole ground lug to the switch rear panel.

Figure 54: Attaching the Ground Lug and Wire Assembly

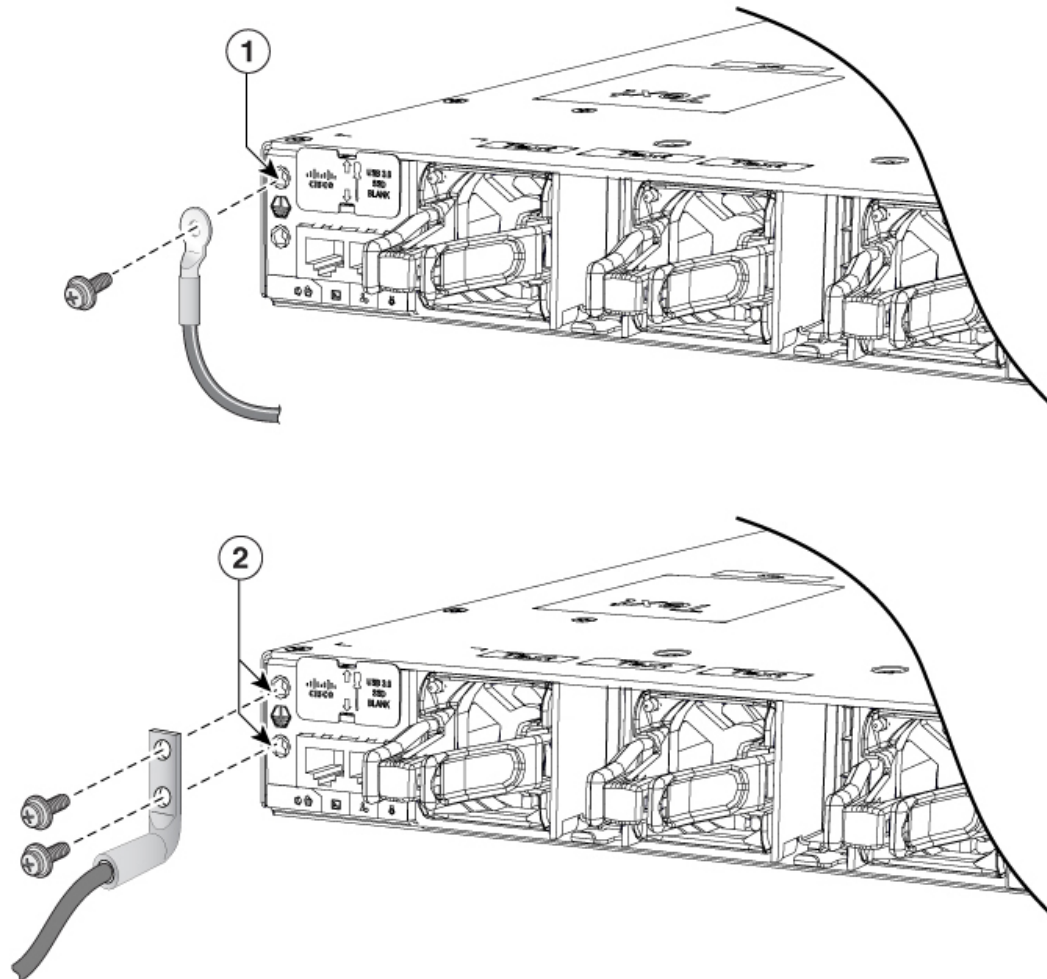

356234

1	Attaching the single-hole ground lug	2	Attaching the dual-hole ground lug
---	--------------------------------------	---	------------------------------------

Step 6 Using a ratcheting torque screwdriver, torque the ground-lug screws to 22-30 lbf-in.

Step 7 Connect the other end of the grounding wire to an appropriate grounding point at your site or to the rack.

Installing the DC Power Supply in the Switch

Before you begin

Before installing the power supply, see the [Installation Guidelines, on page 86](#).

Procedure

- Step 1** Verify that the power supply is not connected to any power sources.
- Step 2** Remove the plastic safety cover from the power supply terminal blocks.
- Note** If you are not replacing a DC power supply, go to Step 5.
- Step 3** Use a number-2 Phillips screwdriver to remove the DC-input power wires from the power terminals.
- Step 4** Press the release latch at the right side of the power supply module inward, and pull the power supply out.
- Step 5** Insert the power supply in the power-supply slot, and gently push it into the slot. When correctly installed, the DC power supply (excluding the extraction handle) is flush with the switch rear panel.

Figure 55: Inserting a DC-Power Supply

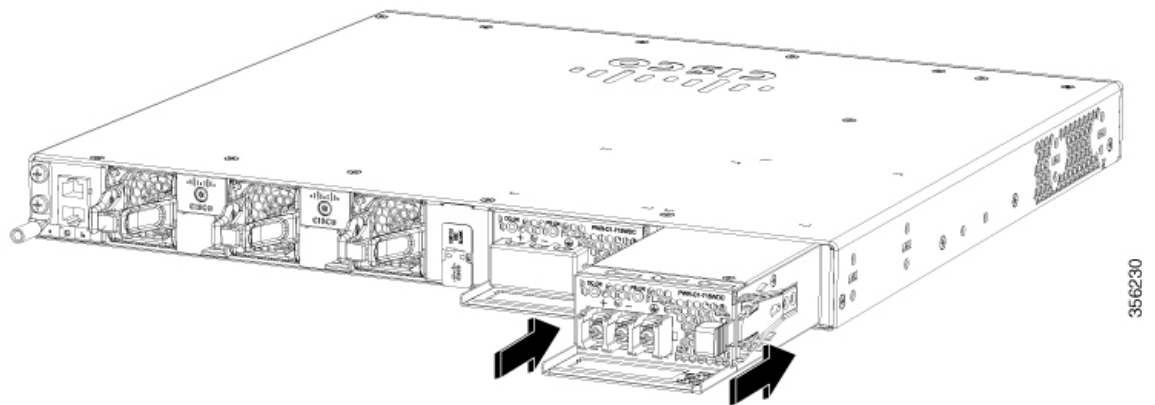

- Step 6** Connect the input power as described in [Wiring the DC Input Power Source, on page 93](#).

Wiring the DC Input Power Source

Procedure

- Step 1** Using a wire-stripping tool, strip the wires from the DC-input power source to the appropriate length for the terminals.
- Warning** Use copper conductors only. Statement 1025
- Step 2** Using a Panduit crimping tool, crimp the fork-type terminals to the copper conductor, 90C, 12-AWG DC power input wires.
- Step 3** Connect the DC-input power terminals to the terminal blocks. Connect the ground wire to a grounded metal rack or to earth ground if the switch is not in a grounded rack.

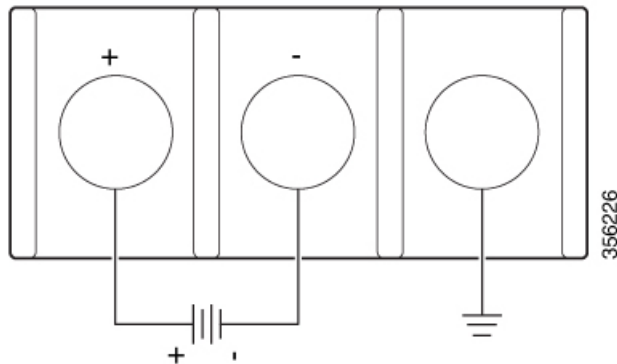
Figure 56: DC Connection with Ground

- Step 4** Torque all terminal block screws to 11 lbf-in.
- Step 5** Replace the terminal block safety cover and turn on the power at the power source.
- Step 6** Confirm that the power supply DC OK and PS OK LEDs are green.

Finding the Power Supply Module Serial Number

If you contact Cisco Technical Assistance regarding a power supply module, you need to know the serial number. See the following illustrations to find the serial number. You can also use the CLI to find out the serial number.

Figure 57: 1100-W AC Power Supply Serial Number

Figure 58: 715-W and 350-W AC Power Supply Serial Number



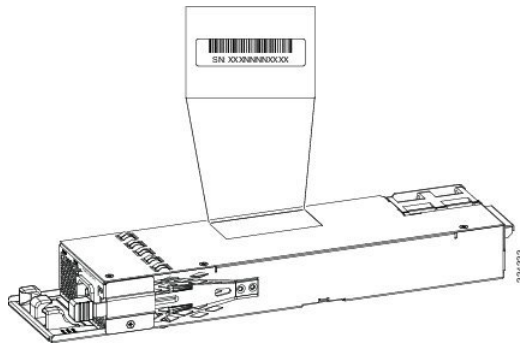
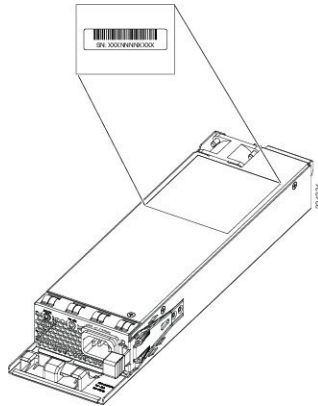

CHAPTER 6

Installing a Fan Module

- [Fan Modules Overview](#) , on page 97
- [Installation Guidelines](#), on page 98
- [Installing a Fan Module](#), on page 98
- [Finding the Fan Module Serial Number](#), on page 99

Fan Modules Overview

All the switches except C9300LM-48T-4Y have three internal hot-swappable fans. A powered switch should always have more than one operational fan. The switch can operate with two operational fans and one nonfunctional fan, but the failed fan should be replaced as soon as possible to avoid a service interruption due to a second fan fault. A switch with one or more fans failed or removed will operate with fans at a faster speed, producing increased sound.



Danger Sharp edges on the fan module can cause serious injury. Keep fingers clear.

Figure 59: Fan Module

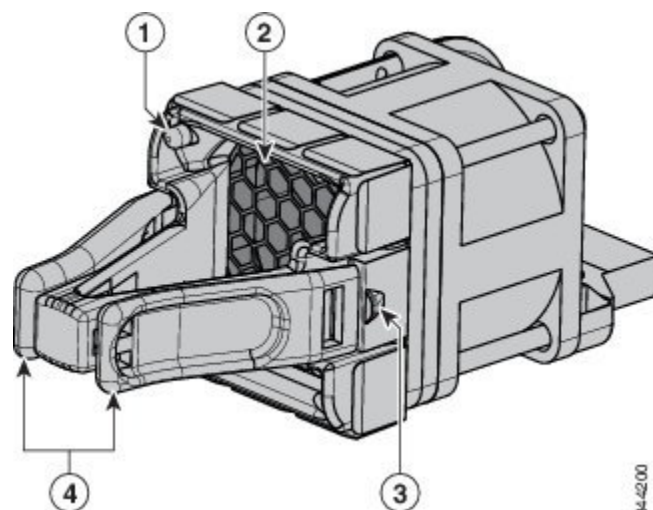

1	Fan LED	3	Retainer clip
---	---------	---	---------------

2	Exhaust vent	4	Extraction handles
---	--------------	---	--------------------



Note The switch requires three fans for proper cooling.

Installation Guidelines

Observe these guidelines when removing or installing a fan module:

- Do not force the fan module into the slot. This can damage the pins on the switch if they are not aligned with the module.
- A fan module that is only partially connected to the switch can disrupt the system operation.
- The switch supports hot swapping of the fan module. You can remove and replace the module without interrupting normal switch operation.



Warning Only trained and qualified personnel should be allowed to install, replace, or service this equipment. Statement 1030

Installing a Fan Module

Procedure

Step 1 Pinch the fan module release handle, and slide the module out.

Caution You should replace the fan module within 5 minutes to avoid overheating the switch.

Step 2 Install the fan module in the fan slot, and firmly push it into the slot, applying pressure to the end of the module, not the extraction handles. When correctly inserted, the fan module is flush with the switch rear panel. When the fan is operating, a green LED is on in the top left corner of the fan.

Warning Do not reach into a vacant slot when installing or removing a module. Exposed circuitry is an energy hazard. Statement 206

Figure 60: Installing the Fan Module

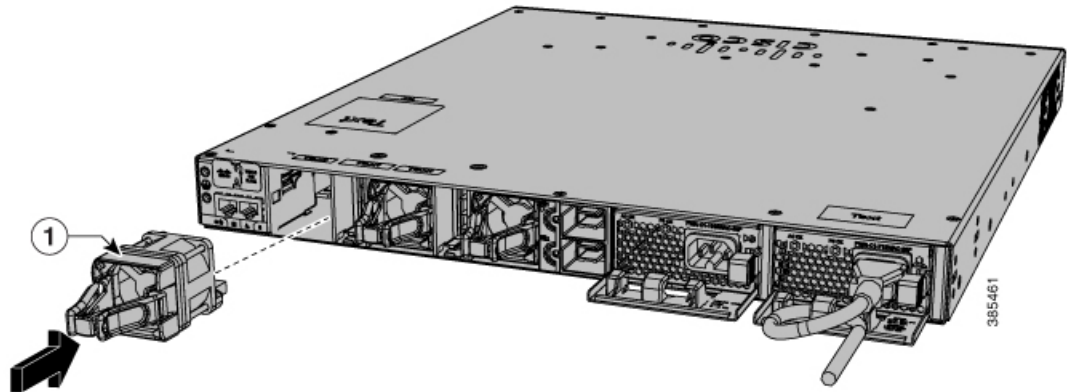

1	Fan LED
---	---------

Note Ensure that the fans are inserted correctly to match the corresponding power supplies. Fans with blue handles correspond to power supplies with blue handles, and fans with red handles correspond to power supplies with red handles.

Finding the Fan Module Serial Number

If you contact Cisco Technical Assistance regarding a fan module, you need to know the fan module serial number. See the following illustration to find the serial number.

Figure 61: Fan Module Serial Number

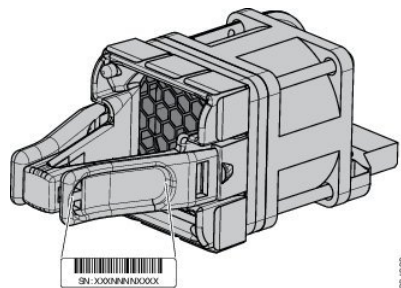



CHAPTER

7

Installing a USB 3.0 SSD

- [USB 3.0 SSD Overview, on page 101](#)
- [Installing an SSD Module on C9300, C9300X and C9300L Switches, on page 102](#)
- [Installing an SSD Module on C9300LM Switches, on page 104](#)

USB 3.0 SSD Overview

The USB 3.0 Solid State Drive (SSD) port on the rear panel of the switch supports an optional 120 GB USB 3.0 SSD (SSD-120G) and 240 GB USB 3.0 SSD (SSD-240G) storage devices. SSD-120G provides an extra 120GB and SSD-240G provides 240 GB of storage for application hosting.

Applications can be hosted in KVM (Kernel-based Virtual Machines), LXC (Linux Containers), or Docker containers. USB 3.0 SSD can also be used to save packet captures, trace logs generated by the operating system, Graceful Insertion and Removal (GIR) snapshots and third-party applications. It can be used simultaneously as a general-purpose storage device and as an app hosting device. You must use only Cisco USB drives; non-Cisco USB drives are not supported.



Note Application hosting on C9300LM switches is supported only with SSD-240G on the USB Type A port on the front panel of the switch.

USB 3.0 SSD is enabled with S.M.A.R.T (Self-Monitoring, Analysis and Reporting Technology) functionality to monitor endurance, predict wear-out and carry out various self-tests.

Figure 62: SSD-120G

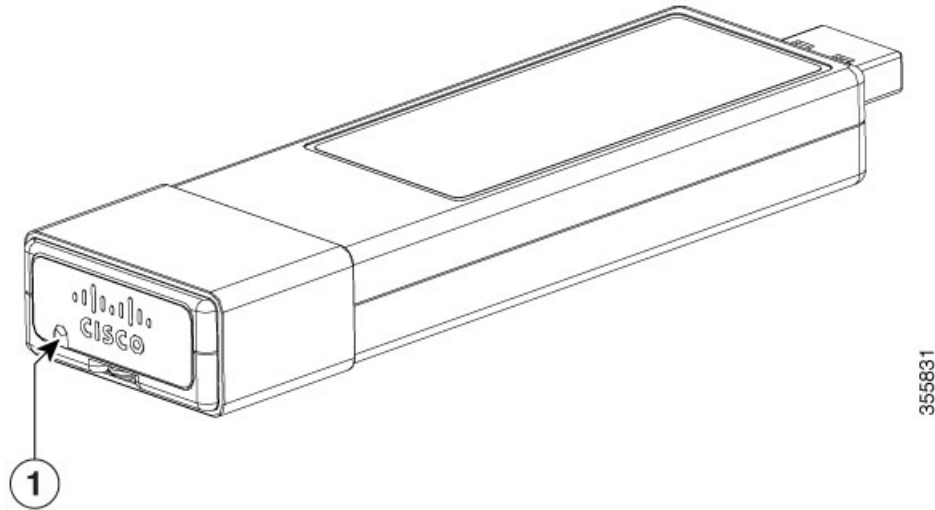

1	Status LED
---	------------

Installing an SSD Module on C9300, C9300X and C9300L Switches

Procedure

-
- Step 1** Remove the blank cover on the USB 3.0 SSD slot on the switch and store it for future use.
 - Step 2** Insert the SSD into the module slot, and firmly push it into the slot. Make sure you insert the SSD in such a way that the Cisco label on the drive stays upright.

Figure 63: Installing an SSD on a Cisco Catalyst 9300 or 9300X Series Switches

This image displays installing an SSD module on to the USB3.0–SSD port on the rear panel of the switch.

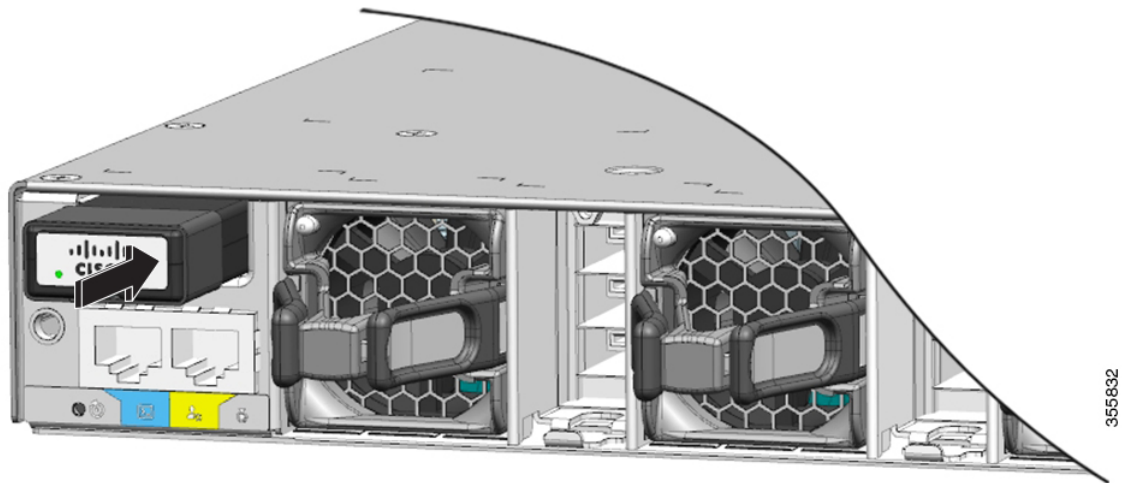
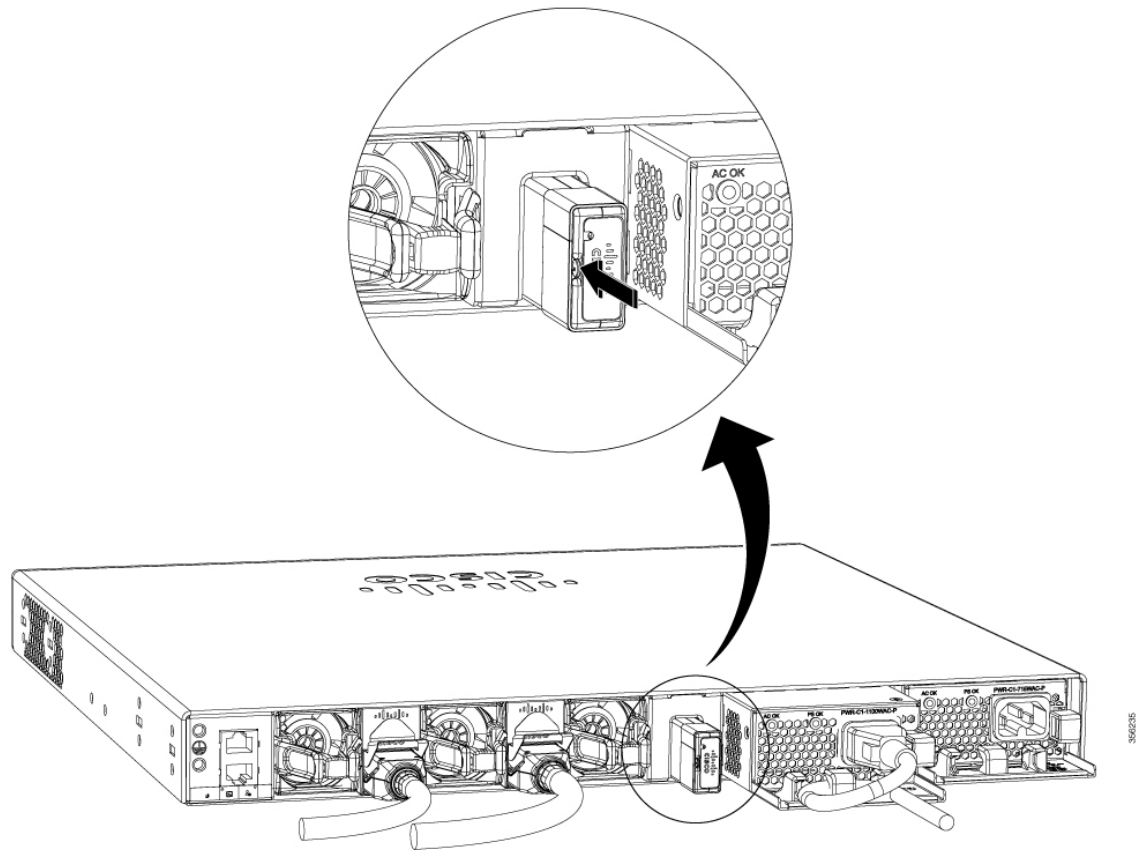

Figure 64: Installing SSD on a Cisco Catalyst 9300L Series Switch

This image displays installing an SSD module on to the USB3.0-SSD port on the rear panel of a C9300L switch.



Step 3 Verify that the LED on SSD turns solid green.

What to do next

For information about formatting and unmounting an SSD, see "Configuring USB 3.0 SSD" section in the *Interface and Hardware Components Configuration Guide*.

Installing an SSD Module on C9300LM Switches

Procedure

- Step 1** Remove the blank cover on the USB 3.0 SSD slot on the switch and store it for future use.
- Step 2** Using the two screws provided with the kit, secure the bracket to the switch as shows in the following figure.

Figure 65: Securing the Bracket to the Switch

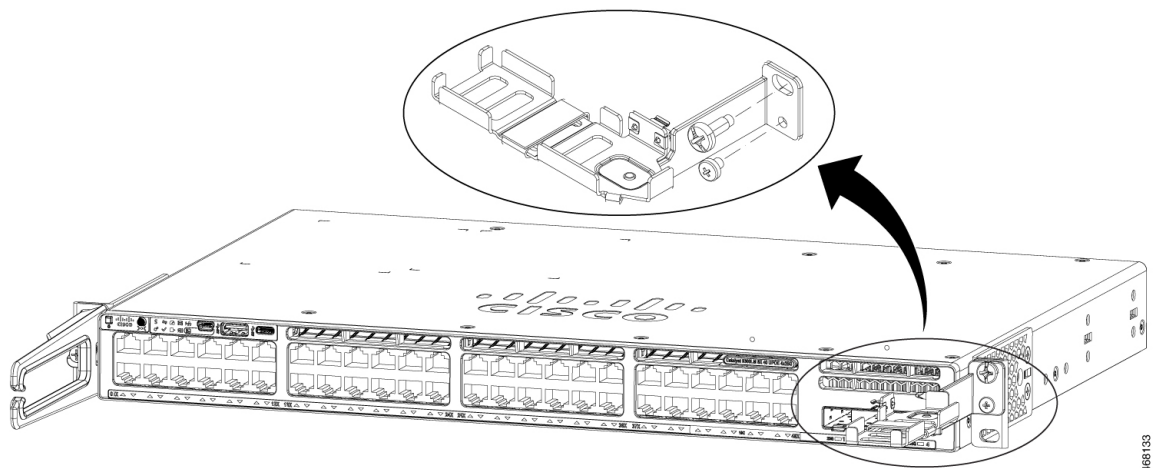

- Step 3** Place the SSD on the bracket. To access the SFP uplink ports underneath the brackets, you can rotate the bracket at an angle of 90^0 to close or open the brackets. Make sure your insert the SSD in such a way that the Cisco label on the drive stays upright.
- Step 4** Connect one end of the USB cable to the SSD module and the other side of the cable to the USB 3.0 type A port on the front panel of the switch.
- Step 5** Secure the USB cable to the RJ45 cables using the velcro strap available on the USB cable.

Figure 66: Installing SSD on a Cisco Catalyst 9300LM Series Switch

This image displays installing an SSD module on to the USB 3.0 type A port on the front panel of a C9300LM switch.

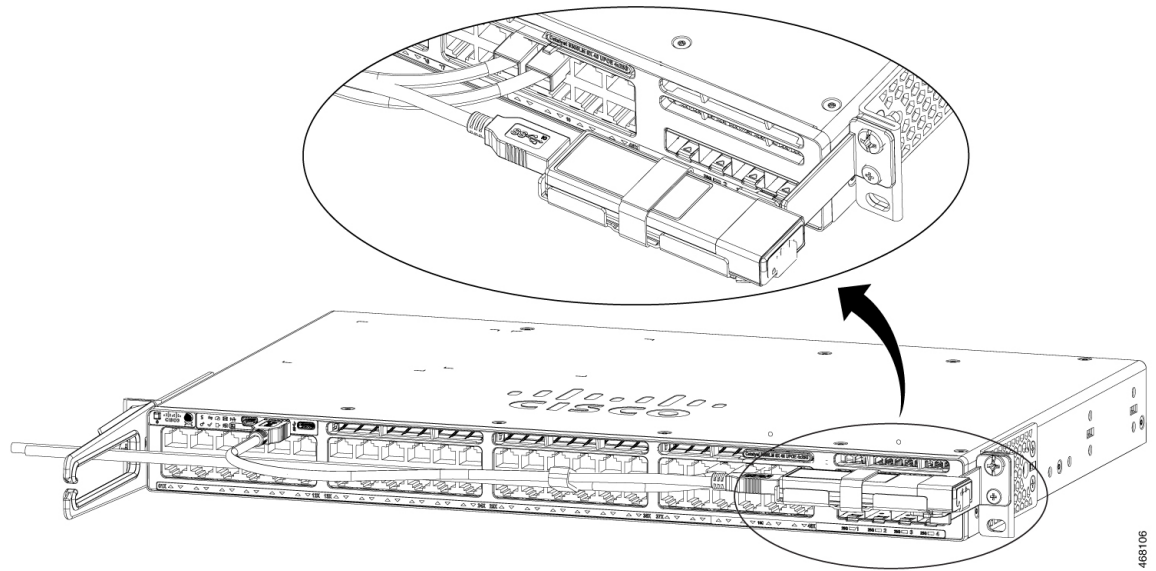

Step 6 Verify that the LED on SSD turns solid green.

What to do next

For information about formatting and unmounting an SSD, see "Configuring USB 3.0 SSD" section in the *Interface and Hardware Components Configuration Guide*.



CHAPTER 8

Configuring the Switch

- [Configuring the Switch Using the Web User Interface, on page 107](#)
- [Configuring the Switch Using the CLI, on page 107](#)

Configuring the Switch Using the Web User Interface

For instructions on setting up the switch using the WebUI, refer to the required version of the [software configuration guide](#). In the guide, go to *Configuring the Switch Using the Web User Interface*.

Configuring the Switch Using the CLI

Accessing the CLI Through the Console Port

You can access the CLI on a configured or unconfigured switch by connecting the RJ-45 console port or USB console port of the switch to your PC or workstation and accessing the switch through a terminal emulation program.



Note If you have stacked your switches, connect to the console port of one of the switches in the stack. You can initially configure the entire stack from any member switch.

Connecting the RJ45 Console Port

Procedure

- Step 1** Connect the RJ45 port adapter to the serial port on the terminal server or your PC using the optional RJ45-to-DB9 adapter cable. Connect the other end of the cable to the switch console port.
- Step 2** Start the terminal-emulation program on the PC or the terminal. The program, frequently a PC application such as Putty or TeraTerm, makes communication between the switch and your PC or terminal possible.
- Step 3** Configure the baud rate and character format of the PC or terminal to match the console port default characteristics:

- 9600 baud
- 8 data bits
- 1 stop bit
- No parity
- None (flow control)

Step 4 Power on the switch.

Step 5 The PC or terminal displays the bootloader sequence. Press **Enter** to display the setup prompt.

Connecting the USB Console Port

Before you begin

The Cisco Catalyst 9300 Series Switches will either have the Cisco USB Device or Silicon Labs USB Device (CP2102N). To identify which USB device is in the switch, do the following:

1. Connect a USB cable from the Windows-based PC or Mac-based PC to the USB console port.
2. On the Windows-based PC, open the Device Manager or on the Mac-based PC, open the System Report and view the following:

Type of USB Device	Device Name
Cisco USB device	Cisco USB Console or USB Serial Device
Silicon Labs USB device	Silicon Labs CP210x USB to UART Bridge or CP2102N USB to UART Bridge

Procedure

Step 1 To install the USB driver to a Windows-based PC or Mac-based PC for the first time, do the following:

Windows-based PC

- For Cisco USB Device, see [Installing the Microsoft Windows USB Device Driver, on page 109](#).
- For Silicon Labs USB Device, you can either download the USB driver from the Silicon Labs [website](#) or see [Installing the Silicon Labs Windows USB Device Driver, on page 110](#).

Mac-based PC

- For Cisco USB Device, no driver installation is required.
- For Silicon Labs USB Device, you can download the USB driver from the Silicon Labs [website](#). Once the installation is completed, a virtual COM port session, "tty.SLAB_USBtoUART", will be started.

Note Do not use the generic USB serial driver available on the Mac-based PC.

Note USB Type A port on the switch provides file system support and is **NOT** a console port. See USB Type A Port section.

- Step 2** Connect a USB cable to the PC USB port. Connect the other end of the cable to the switch mini-B (5-pin-connector) USB console port.
- Step 3** Start the terminal-emulation program on the PC or the terminal. The program, frequently a PC application such as Putty or TeraTerm, makes communication between the switch and your PC or terminal possible.
- Step 4** Configure the baud rate and character format of the PC or terminal to match the console port default characteristics:
- 9600 baud
 - 8 data bits
 - 1 stop bit
 - No parity
 - None (flow control)
- Step 5** Power on the switch as described in the switch getting started guide.
- Step 6** The PC or terminal displays the bootloader sequence. Press **Enter** to display the setup prompt. Follow the steps in the Setup program.
-

Installing the Microsoft Windows USB Device Driver

A USB device driver must be installed the first time a Microsoft Windows-based PC is connected to the USB console port on the switch.

Installing the Cisco Microsoft Windows USB Driver

Procedure

- Step 1** Obtain the Cisco USB console driver file from the Cisco.com web site and unzip it.
- Note** You can download the driver file from the Cisco.com site for downloading the switch software.
- Windows 10 includes a USB to RS232 driver. However for added functionality, download the USB Console Software from the Software Download Center for Catalyst 3850 Series Switches at cisco.com.
- Step 2** If using 32-bit Windows, double-click the setup.exe file in the Windows_32 folder. If using 64-bit Windows, double-click the setup(x64).exe file in the Windows_64 folder.
- Step 3** The Cisco Virtual Com InstallShield Wizard begins. Click **Next**.
- Step 4** The Ready to Install the Program window appears. Click **Install**.
- Note** If a User Account Control warning appears, click **Allow - I trust this program** to proceed.
- Step 5** The InstallShield Wizard Completed window appears. Click **Finish**.

- Step 6** Connect the USB cable to the PC and the switch console port. The USB console port LED turns green, and the Found New Hardware Wizard appears. Follow the instructions to complete the driver installation.
-

Installing the Silicon Labs Windows USB Device Driver

Procedure

- Step 1** Connect a USB cable to the PC USB port. Connect the other end of the cable to the switch mini-B (5-pin-connector) USB console port.
- Step 2** Launch the Windows Update page by clicking on the **Update & Security** button on the Windows Settings.
- Step 3** Click **View optional updates**.
- Step 4** Expand **Driver updates** and select **Silicon Laboratories Inc. – Ports 10.x.x.x**.
- Step 5** Click **Download and install** button.

Once the driver installation is complete, disconnect the USB cable from the PC USB port and the switch.

Note Windows assigns different COM ports to Silicon Labs USB device. To view the COM port assignment, see Device Manager.

Uninstalling the Cisco Microsoft Windows USB Driver

Uninstalling the Cisco Microsoft Windows USB Driver

Before you begin

Disconnect the switch console terminal before uninstalling the driver.

Procedure

- Step 1** Run setup.exe for Windows 32-bit or setup(x64).exe for Windows-64bit. Click **Next**.
- Step 2** The InstallShield Wizard for Cisco Virtual Com appears. Click **Next**.
- Step 3** When the Program Maintenance window appears, select the Remove radio button. Click **Next**.
- Step 4** When the Remove the Program window appears, click **Remove**.
- Note** If a User Account Control warning appears, click **Allow - I trust this program to proceed**.
- Step 5** When the InstallShield Wizard Completed window appears, click **Finish**.
-



APPENDIX **A**

Technical Specifications

- [Environmental and Physical Specifications](#), on page 111
- [Specifications for the Power Supplies, Switches, and Fan](#), on page 116
- [AC Power Cord Specifications](#), on page 118

Environmental and Physical Specifications

This table describes the environmental specifications.

Table 34: Environmental Specifications for the Switch

Environmental Ranges	
Operating temperature ⁴	23 to 113°F (–5 to 45°C)
Storage temperature	–40 to 158°F (–40 to 70°C)
Relative humidity	5 to 90% (non-condensing)
Operating altitude	Up to 10,000 ft (3000 m)
Storage altitude	Up to 15,000 ft (4500 m)

⁴ Minimum ambient temperature for cold start is 32°F (0°C)

This table describes the environmental specifications.

Table 35: Environmental Specifications for the Power Supplies

Environmental Ranges	
Operating temperature	23°F to 113°F (–5°C to 45°C) up to 5000 feet (1500m) 23°F to 104°F (–5°C to 40°C) up to 10,000 feet (3000m)
Storage temperature	–40 to 158°F (–40 to 70°C)
Relative humidity	10 to 90% (non-condensing)
Altitude	10,000 ft (3,000 m) up to 40°C

Physical Specifications of the Switch

This table describes the physical specifications with the FAN FRUs and the power supplies installed.

Table 36: Dimensions (H x W x D) of Cisco Catalyst 9300X Series Switches

Switch PID	Dimensions (H x W x D) in inches and centimeter
C9300X-12Y	1.73 x 17.5 x 19.2 in. (4.4 x 44.5 x 48.8 cm)
C9300X-24Y	1.73 x 17.5 x 20.7 in. (4.4 x 44.5 x 52.6 cm)
C9300X-24HX	1.73 x 17.5 x 17.6 in. (4.4 x 44.5 x 44.7 cm)
C9300X-48HX	1.73 x 17.5 x 19 in. (4.4 x 44.5 x 48.3 cm)
C9300X-48HXN	1.73 x 17.5 x 17.6 in. (4.4 x 44.5 x 44.7 cm)
C9300X-48TX	1.73 x 17.5 x 19 in. (4.4 x 44.5 x 48.3 cm)

This table describes the physical specifications with FAN FRUs and default power supplies installed.

Table 37: Dimensions (H x W x D) of Cisco Catalyst 9300LM Series Switches

Switch PID	Dimensions (H x W x D) in inches and centimeter
C9300LM-48T-4Y	1.73 x 17.5 x 12.39 in. (4.4 x 44.5 x 31.5 cm)
C9300LM-24U-4Y	1.73 x 17.5 x 13.17 in. (4.4 x 44.5 x 33.5 cm)
C9300LM-48U-4Y	1.73 x 17.5 x 13.17 in. (4.4 x 44.5 x 33.5 cm)
C9300LM-48UX-4Y	1.73 x 17.5 x 13.17 in. (4.4 x 44.5 x 33.5 cm)

This table describes the maximum dimensions for a switch with FAN FRUs and default power supplies installed.

Table 38: Dimensions (H x W x D) of Cisco Catalyst 9300L Series Switches

Switch PID	Dimensions (H x W x D) in inches and centimeter
C9300L-24P-4G	1.73 x 17.5 x 19.2 in. (4.4 x 44.5 x 48.8 cm)
C9300L-24P-4X	1.73 x 17.5 x 19.2 in. (4.4 x 44.5 x 48.8 cm)
C9300L-24T-4G	1.73 x 17.5 x 19.2 in. (4.4 x 44.5 x 48.8 cm)
C9300L-24T-4X	1.73 x 17.5 x 19.2 in. (4.4 x 44.5 x 48.8 cm)
C9300L-48P-4G	1.73 x 17.5 x 19.2 in. (4.4 x 44.5 x 48.8 cm)
C9300L-48T-4G	1.73 x 17.5 x 19.2 in. (4.4 x 44.5 x 48.8 cm)
C9300L-48P-4X	1.73 x 17.5 x 19.2 in. (4.4 x 44.5 x 48.8 cm)
C9300L-48T-4X	1.73 x 17.5 x 19.2 in. (4.4 x 44.5 x 48.8 cm)

Switch PID	Dimensions (H x W x D) in inches and centimeter
C9300L-48PF-4G	1.73 x 17.5 x 19.2 in. (4.4 x 44.5 x 48.8 cm)
C9300L-48PF-4X	1.73 x 17.5 x 19.2 in. (4.4 x 44.5 x 48.8 cm)
C9300L-24UXG-4X	1.73 x 17.5 x 19.2 in. (4.4 x 44.5 x 48.8 cm)
C9300L-24UXG-2Q	1.73 x 17.5 x 19.2 in. (4.4 x 44.5 x 48.8 cm)
C9300L-48UXG-4X	1.73 x 17.5 x 19.2 in. (4.4 x 44.5 x 48.8 cm)
C9300L-48UXG-2Q	1.73 x 17.5 x 19.2 in. (4.4 x 44.5 x 48.8 cm)

This table describes the physical specifications with FAN FRUs and default power supplies installed.

Table 39: Dimensions (H x W x D) of Cisco Catalyst 9300 Series Switches

Switch PID	Dimensions (H x W x D) in inches and centimeter
C9300-24H	1.73 x 17.5 x 19.2 in. (4.4 x 44.5 x 48.8 cm)
C9300-24P	1.73 x 17.5 x 19.2 in. (4.4 x 44.5 x 48.8 cm)
C9300-24S	1.73 x 17.5 x 20.7 in. (4.4 x 44.5 x 52.6 cm)
C9300-24T	1.73 x 17.5 x 19.2 in. (4.4 x 44.5 x 48.8 cm)
C9300-24U	1.73 x 17.5 x 19.2 in. (4.4 x 44.5 x 48.8 cm)
C9300-24UB	1.73 x 17.5 x 19.2 in. (4.4 x 44.5 x 48.8 cm)
C9300-24UX	1.73 x 17.5 x 20.2 in. (4.4 x 44.5 x 51.3 cm)
C9300-24UXB	1.73 x 17.5 x 20.2 in. (4.4 x 44.5 x 51.3 cm)
C9300-48H	1.73 x 17.5 x 19.2 in. (4.4 x 44.5 x 48.8 cm)
C9300-48P	1.73 x 17.5 x 19.2 in. (4.4 x 44.5 x 48.8 cm)
C9300-48S	1.73 x 17.5 x 20.7 in. (4.4 x 44.5 x 52.6 cm)
C9300-48T	1.73 x 17.5 x 19.2 in. (4.4 x 44.5 x 48.8 cm)
C9300-48U	1.73 x 17.5 x 19.2 in. (4.4 x 44.5 x 48.8 cm)
C9300-48UB	1.73 x 17.5 x 19.2 in. (4.4 x 44.5 x 48.8 cm)
C9300-48UN	1.73 x 17.5 x 22.2 in. (4.4 x 44.5 x 56.4 cm)
C9300-48UXM	1.73 x 17.5 x 22.2 in. (4.4 x 44.5 x 56.4 cm)

This table describes the weight of the switch with FAN FRUs and default power supplies installed.

Table 40: Weight Measurements of Switches

Cisco Catalyst 9300X Series Switches	C9300X-12Y - 15.0 lb (6.80 kg) C9300X-24Y - 16.2 lb (7.35 kg) C9300X-48HX - 14.6 lb (6.62 kg) C9300X-48TX - 14.6 lb (6.62 kg) C9300X-24HX - 17 lb (7.71 kg) C9300X-48HXN - 17.5 lb (7.93 kg)
Cisco Catalyst 9300L Series Switches	C9300L-24P-4G - 14.99 lb (6.81 kg) C9300L-24P-4X - 14.99 lb (6.81 kg) C9300L-24T-4G - 14.93 lb (6.78 kg) C9300L-24T-4X - 14.93 lb (6.78 kg) C9300L-48P-4G - 15.46 lb (7.03 kg) C9300L-48T-4G - 15.41 lb (7.0 kg) C9300L-48P-4X - 15.46 lb (7.03 kg) C9300L-48T-4X - 15.41 lb (7.01 kg) C9300L-48PF-4G - 15.48 lb (7.03 kg) C9300L-48PF-4X - 15.48 lb (7.03 kg) C9300L-24UXG-4X - 15.73 lb (7.12 kg) C9300L-24UXG-2Q - 16.01 lb (7.26 kg) C9300L-48UXG-4X - 16.86 lb (7.65 kg) C9300L-48UXG-2Q - 16.86 lb (7.65 kg)
Cisco Catalyst 9300LM Series Switches	C9300LM-24U-4Y - 11.5 lb (5.22 kg) C9300LM-48T-4Y - 11 lb (5 kg) C9300LM-48U-4Y - 12 lb (5.44 kg) C9300LM-48UX-4Y - 12 lb (5.44 kg)

Cisco Catalyst 9300 Series Switches	C9300-24H - 16.63 lb (7.54 kg)
	C9300-24P - 16.33 lb (7.4 kg)
	C9300-24S - 14.42 lb (6.54 kg)
	C9300-24T - 16.03 lb (7.27 kg)
	C9300-24U - 16.63 lb (7.54 kg)
	C9300-24UB - 16.63 lb (7.54 kg)
	C9300-24UX - 18.18 lb (8.25 kg)
	C9300-48H - 17.03 lb (7.72 kg)
	C9300-24UXB - 18.18 lb (8.25 kg)
	C9300-48P - 16.73 lb (7.59 kg)
	C9300-48S - 14.91 lb (6.76 kg)
	C9300-48T - 16.43 lb (7.45 kg)
	C9300-48U - 17.03 lb (7.72 kg)
	C9300-48UB - 17.03 lb (7.72 kg)
	C9300-48UN - 20.05 lb (9.09 kg)
C9300-48UXM - 20.5 lb (9.34 kg)	

Physical Specifications of Power Supplies

Weight	
PWR-C1-1100WAC	3 lb (1.4 kg)
PWR-C1-715WAC	2.8 lb (1.3 kg)
PWR-C1-350WAC	2.6 lb (1.2 kg)
PWR-C1-1900WAC-P	3.4 lb (1.5 kg)
PWR-C1-1100WAC-P	3.1 lb (1.4 kg)
PWR-C1-715WAC-P	2.6 lb (1.2 kg)
PWR-C1-350WAC-P	2.3 lb (1.2 kg)
PWR-C1-715WDC	2.8 lb (1.3 kg)
PWR-C6-600WAC	1.7 lb (0.77 kg)
PWR-C6-1KWAC	2 lb (0.9 kg)
Dimensions (H x D x W)	
The dimensions shown include the extraction handle and the keying feature.	
PWR-C1-1100WAC	1.58 X 3.25 X 13.7 in. (40.1 X 82.55 X 348.2 mm)

PWR-C1-715WAC	1.58 X 3.25 X 12.20 in. (40.1 X 82.55 X 309.9 mm)
PWR-C1-350WAC	1.58 X 3.25 X 12.20 in. (40.1 X 82.55 X 309.9 mm)
PWR-C1-1900WAC-P	1.58 X 3.25 X 13.7 in. (40.1 X 82.55 X 348.2 mm)
PWR-C1-1100WAC-P	1.58 X 3.25 X 13.7 in. (40.1 X 82.55 X 348.2 mm)
PWR-C1-715WAC-P	1.58 X 3.25 X 12.20 in. (40.1 X 82.55 X 309.9 mm)
PWR-C1-350WAC-P	1.58 X 3.25 X 12.20 in. (40.1 X 82.55 X 309.9 mm)
PWR-C1-715WDC	1.58 X 3.25 X 12.20 in. (40.1 X 82.55 X 309.9 mm)
PWR-C6-600WAC	1.58 x 4.0 x 7.6 in. (40.1 X 101.6 X 193 mm)
PWR-C6-1KWAC	1.58 x 4.0 x 7.6 in. (40.1 X 101.6 X 193 mm)

Specifications for the Power Supplies, Switches, and Fan

Table 41: Power Specifications for Platinum Rated AC Power Supplies

Specification	Power Supply				
	PWR-C1-1900WAC-P	PWR-C1-1100WAC-P	PWR-C1-715WAC-P	PWR-C1-350WAC-P	
Maximum output power	1900 W with 230 V	1500 W with 115 V	1100 W	715 W	350 W
Input voltage and frequency	1900 W, 200 V to 240 VAC (autoranging), 55-60 Hz	1500 W, 115 V to 127 VAC (autoranging), 50-60 Hz	1100 W, 115 to 240 VAC (autoranging), 50-60 Hz	715 W, 100 to 240 VAC (autoranging), 50-60 Hz	350 W, 100 to 240 VAC (autoranging), 50-60 Hz
Input current	maximum of 12 A	maximum of 16 A	12-6 A	10-5 A	4-2 A
Output ratings	-56 V@33.92 A	-56 V@26.78 A	-56 V@19.64 A	-56 V@12.8 A	-56 V@6.25 A
Total input BTU ⁵	6899 BTUs per hour, 2022 W	5565 BTUs per hour, 1631 W	4147 BTUs per hour, 1215 W	2723 BTUs per hour, 798 W	1348 BTUs per hour, 395 W
Total output BTU	6483 BTU per hour, with 230 V	5118 BTU per hour, with 115 V	3754 BTUs per hour, 1100 W	2440 BTUs per hour, 715 W	1194 BTUs per hour, 350 W

⁵ The total input and total output BTU ratings refer to input power to the power supply and output power to the switch. The BTU ratings are based on 100 VAC for the 350 W and 715 W power supplies and 115 VAC for the 1100 W power supply.

Table 42: Power Specifications for AC Power Supplies

Specification	Power Supply		
	PWR-C1-1100WAC	PWR-C1-715WAC	PWR-C1-350WAC
Maximum output power	1100 W	715 W	350 W
Input voltage and frequency	1100 W, 115 to 240 VAC (autoranging), 50-60 Hz	715 W, 100 to 240 VAC (autoranging), 50-60 Hz	350 W, 100 to 240 VAC (autoranging), 50-60 Hz
Input current	12-6 A	10-5 A	4-2 A
Output ratings	-56 V@19.64 A	-56 V@12.8 A	-56 V@6.25 A
Total input BTU ⁶	4211 BTUs per hour, 1234 W	2774 BTUs per hour, 813 W	1375 BTUs per hour, 403 W
Total output BTU	3754 BTUs per hour, 1100 W	2440 BTUs per hour, 715 W	1194 BTUs per hour, 350 W

⁶ The total input and total output BTU ratings refer to input power to the power supply and output power to the switch. The BTU ratings are based on 100 VAC for the 350 W and 715 W power supplies and 115 VAC for the 1100 W power supply.

Table 43: Power Specifications for AC Power Supplies for C9300LM

Specification	Power Supply	
	PWR-C6-600WAC	PWR-C6-1KWAC
Maximum output power	600 W	1000 W
Input voltage and frequency	100 to 240 VAC (autoranging) 50-60 Hz	100 to 240 VAC (autoranging) 50-60 Hz
Input current	7-2.8 A	12-6 A
Output ratings	54V @ 11.1 A	54V @ 18.5 A
Total input BTU ⁷	2327 BTUs per hour	3876 BTUs per hour
Total output BTU	2047.3 BTUs per hour	3412 BTUs per hour

⁷ The total input and total output BTU ratings refer to input power to the power supply and output power to the switch. The BTU ratings are based on 100 VAC.

Table 44: Power Specifications for DC Power Supplies

Power Requirements	
Specification	PWR-C1-715WDC
Maximum output power	715 W

Power Requirements	
Specification	PWR-C1-715WDC
Input current	24–12 A
Output ratings	-56 V at 12.8 A
Input voltage range domestic	-36 VDC (minimum), -48 VDC (nominal), -72 VDC (maximum)
Voltage range international	-36 VDC (minimum), -48 VDC (nominal), -72 VDC (maximum)
Total input BTU ⁸	PWR-C1-715WDC: 2777 BTUs per hour, 715 W
Total output BTU	2440 BTUs per hour
Wire gauge for ground connection	12 AWG or 8 AWG
Branch circuit protection	20 A

⁸ The total input and total output BTU ratings refer to input power to the power supply and output power to the switch. The BTU ratings are based on -40 VDC.

Table 45: Fan Module Environmental and Physical Specifications

Environmental Ranges	
Operating temperature	23 to 176°F (-5 to 80°C)
Storage temperature	-40 to 185°F (-40 to 85°C) up to 15,000 ft (4500 m)
Relative humidity	5 to 95% (non-condensing)
Altitude	Up to 13,000 ft (4000 m)
Physical Specification	
Dimensions (H x D x W)	1.62 x 1.73 x 4.24 in. (4.11 x 4.39 x 10.76 cm)
Weight (for three fans)	0.48 lb (0.21 kg)
Operating Specification	
Airflow	20 cfm

AC Power Cord Specifications

The following table lists the specifications for the AC power cords that are available for the AC-input power supplies.

Table 46: AC Power Cords for PWR-C1-1100WAC, PWR-C1-715WAC, PWC-C1-350WAC, PWR-C1-1100WAC-P, PWR-C1-715WAC-P, and PWC-C1-350WAC-P Power Supplies

Locale	Part Number	Cordset Rating	Length
Argentina	CAB-TA-AR	250 VAC, 10 A	2.5 m
Australia	CAB-TA-AP	250 VAC, 10 A	2.5 m
Brazil	CAB-ACBZ-12A	125 VAC, 12 A	2.5 m
Brazil	CAB-ACBZ-10A	250 VAC, 10 A	2.5 m
China	CAB-TA-CN	250 VAC, 10 A	2.5 m
Denmark	CAB-TA-DN	250 VAC, 10 A	2.5 m
Europe	CAB-TA-EU	250 VAC, 10 A	2.5 m
India	CAB-TA-IN	250 VAC, 10 A	2.5 m
Israel	CAB-TA-IS	250 VAC, 16 A	2.5 m
Italy	CAB-TA-IT	250 VAC, 10 A	2.5 m
Japan	CAB-TA-JP ⁹	125 VAC, 12 A	2.5 m
Japan	CAB-TA-250VAC-JP	250 VAC, 12 A	2.5 m
Korea	CAB-AC-C15-KOR	250 VAC, 10 A	2.5 m
North America	CAB-TA-NA	125 VAC, 12 A	2.5 m
Switzerland	CAB-TA-SW	250 VAC, 10 A	2.5 m
Taiwan	CAB-AC-C15-TW	125 VAC, 15 A	2.5 m
United Kingdom	CAB-TA-UK	250 VAC, 10 A	2.5 m
Cabinet jumper power cord, C14-C15 connectors	CAB-C15-CBN	250 VAC, 13 A	1.22 m

⁹ **Note** This power cord is not rated for use with PWR-C1-1100WAC or PWR-C1-1100WAC-P power supplies.

The following table lists the specifications for the AC power cords that are available for PWR-C1-1900WAC-P power supplies.

Table 47: AC Power Cords for PWR-C1-1900WAC-P

Locale	Part Number	Cordset Rating	Length
North America	C9K-PWR-CAB-AC-US	250 VAC, 20 A	4.25 meter (m)

Locale	Part Number	Cordset Rating	Length
North America	C9K-PWR-CAB-AC-BL (Cabinet jumper power cord)	250 VAC, 20 A	4.25 m
Argentina	C9K-PWR-CAB-AC-AR	250 VAC, 16 A	4.25 m
Australia	C9K-PWR-CAB-AC-AU	250 VAC, 16 A	4.25 m
China	C9K-PWR-CAB-AC-CN	250 VAC, 16 A	4.25 m
Europe	C9K-PWR-CAB-AC-EU	250 VAC, 16 A	4.25 m
India	C9K-PWR-CAB-AC-IN	250 VAC, 16 A	4.25 m
Israel	C9K-PWR-CAB-AC-IS	250 VAC, 16 A	4.25 m
Italy	C9K-PWR-CAB-AC-IT	250 VAC, 16 A	4.25 m
Japan	C9K-PWR-CAB-AC-JP	250 VAC, 20 A	4.25 m
North America	C9K-CAB-US520PC21	125 VAC, 20 A	2.5 m
South Africa	C9K-PWR-CAB-AC-SA	250 VAC, 16 A	4.25 m
United Kingdom	C9K-PWR-CAB-AC-UK	250 VAC, 16 A	4.25 m



APPENDIX **B**

Connector and Cable Specifications

- [Connector Specifications, on page 121](#)
- [Console Port, on page 123](#)
- [Cables and Adapters, on page 123](#)

Connector Specifications

10/100/1000 Ports (Including PoE)

All 10/100/1000 ports use standard RJ-45 connectors and Ethernet pinouts.

Figure 67: 10/100/1000 Port Pinouts

Pin	Label	1	2	3	4	5	6	7	8
1	TP0+								
2	TP0-								
3	TP1+								
4	TP2+								
5	TP2-								
6	TP1-								
7	TP3+								
8	TP3-								

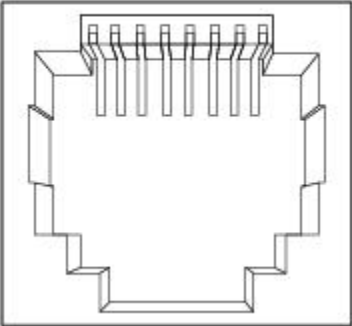

Module Connectors

Figure 68: Duplex LC Cable Connector

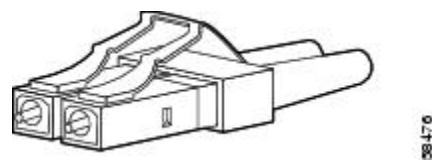

Figure 69: Simplex LC Cable Connector

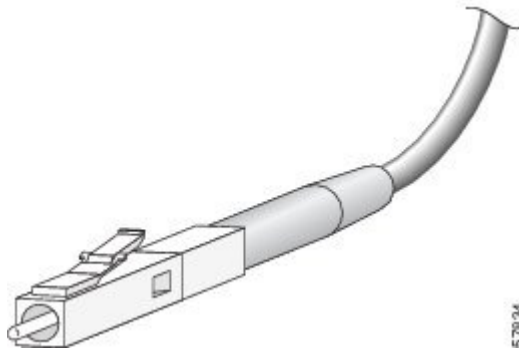

Figure 70: Copper SFP Module LC Connector

Pin	Label	1	2	3	4	5	6	7	8
1	TP0+								
2	TP0-								
3	TP1+								
4	TP2+								
5	TP2-								
6	TP1-								
7	TP3+								
8	TP3-								

MPO-12 Connectors

The multi-fiber push on (MPO) connector is a 12-fiber optical connector with a footprint similar to the SC simplex connector. The MPO connector conforms to the TIA/EIA-604-5 intermateability standard. It is used for establishing 40G and 100G optical parallel connections.

Figure 71: MPO-12 Fiber-Optic Connector

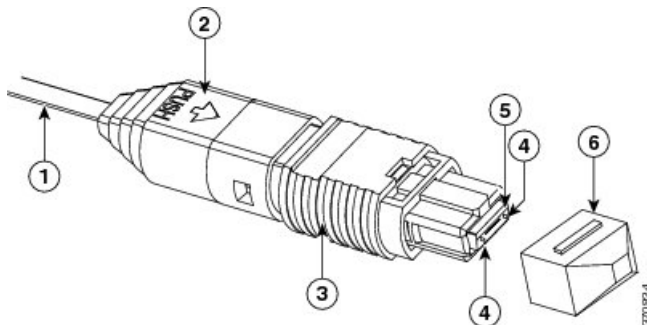

1	12-fiber ribbon	4	Guide pins
2	Boot	5	Ferrule

3	Housing assembly	6	Dust cap
---	------------------	---	----------



Note You have to attach an adapter cable to this connector.

Console Port

The switch has two console ports: a USB 5-pin mini-Type B port on the front panel and an RJ-45 console port on the rear panel.

Figure 72: USB Mini-Type B Port

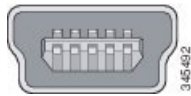

The USB console port uses a USB Type A to 5-pin mini-Type B cable. The USB Type A-to-USB mini-Type B cable is not supplied. You can order an accessory kit (part number 800-33434) that contains this cable.

Figure 73: USB Type A-to-USB 5-Pin Mini-Type B Cable

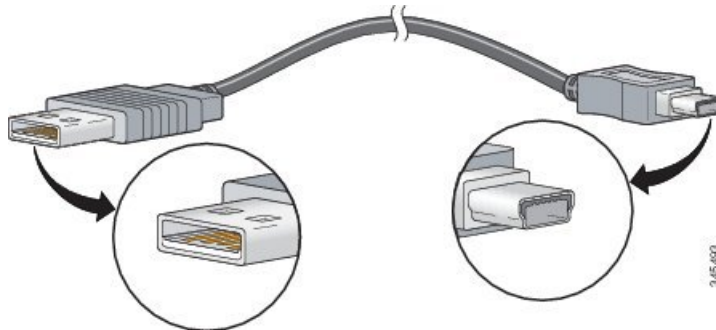

The RJ-45 console port uses an 8-pin RJ-45 connection. The supplied RJ-45-to-DB-9 adapter cable is used to connect the console port of the switch to a console PC. You need to provide a RJ-45-to-DB-25 female DTE adapter if you want to connect the switch console port to a terminal.

Cables and Adapters

StackWise Accessories

All Cisco stack cables are halogen-free. The StackWise cables of lengths 0.5 m, 1 m and 3 m supported. You can order the stacking cables from your Cisco sales representative.

Table 48: Cisco StackWise-480 and StackWise-1T Accessories for C9300 and C9300X Series Switches

Product ID	Product Description
STACK-T1-50CM	50 cm stacking cable for Cisco StackWise-480 and Cisco StackWise-1T
STACK-T1-1M	1 m stacking cable for Cisco StackWise-480 and Cisco StackWise-1T
STACK-T1-3M	3 m stacking cable for Cisco StackWise-480 and Cisco StackWise-1T

The optional StackWise-320 kit for Catalyst 9300L and 9300LM Series models consists of two stack adapters and a stacking cable. The default stacking cable is 0.5 m, however options of 1m and 3m are also available.

Table 49: Cisco StackWise-320 Accessories for C9300L Series Switches

Product ID	Product Description
C9300L-STACK	Stacking adapter for C9300L Series Switches that is used in conjunction with STACK-T3 type cables
C9300L-STACK-A	Stacking adapter for C9300L and C9300LM Series Switches that is used in conjunction with STACK-T3A type cables
STACK-T3-50CM	50 cm stacking cable for C9300L Series Switches
STACK-T3-1M	1 m stacking cable for C9300L Series Switches
STACK-T3-3M	3 m stacking cable for C9300L Series Switches
STACK-T3A-50CM	50 cm stacking cable for C9300L and C9300LM Series Switches
STACK-T3A-1M	1 m stacking cable for C9300L and C9300LM Series Switches
STACK-T3A-3M	3 m stacking cable for C9300L and C9300LM Series Switches



Note C9300L Series Switches use both T3 and T3A type stacking cables.

The optional StackWise-320 kit for Catalyst 9300L and 9300LM Series models consists of two stack adapters and a stacking cable. The default stacking cable is 0.5 m, however options of 1m and 3m are also available.

Table 50: Cisco StackWise-320 Accessories for C9300LM Series Switches

Product ID	Product Description
C9300L-STACK-A	Stacking adapter for C9300L and C9300LM Series Switches that is used in conjunction with STACK-T3A type cables
STACK-T3A-50CM	50 cm stacking cable for C9300L and C9300LM Series Switches
STACK-T3A-1M	1 m stacking cable for C9300L and C9300LM Series Switches
STACK-T3A-3M	3 m stacking cable for C9300L and C9300LM Series Switches



Note C9300LM Series Switches use only T3A type stacking cables.

Table 51: StackWise Cables Minimum Bend Radius and Coiled Diameter

Cable Part Number	Cable Length	Minimum Bend Radius	Minimum Coiled Diameter
STACK-T1-50CM	1.64 feet (0.5 m)	1.6 in. (41 mm)	Not applicable
STACK-T1-1M	3.28 feet (1.0 m)	1.6 in. (41 mm)	5.2 in. (132 mm)
STACK-T1-3M	9.84 feet (3.0 m)	3.2 in. (82 mm)	7.17 in. (182 mm)
STACK-T3-50CM	1.64 feet (0.5 m)	1.6 in. (41 mm)	Not applicable
STACK-T3-1M	3.28 feet (1.0 m)	1.6 in. (41 mm)	5.20 in. (132 mm)
STACK-T3-3M	9.84 feet (3.0 m)	3.2 in. (82 mm)	7.17 in. (182 mm)
STACK-T3A-50CM	1.64 feet (0.5 m)	1.6 in. (41 mm)	Not applicable
STACK-T3A-1M	3.28 feet (1.0 m)	1.6 in. (41 mm)	5.20 in. (132 mm)
STACK-T3A-3M	9.84 feet (3.0 m)	3.2 in. (82 mm)	7.17 in. (182 mm)

1. With a 0.5 m cable, the minimum coiled diameter is negligible and the cable cannot be physically coiled without exceeding the bending limit.

Transceiver Module Network Cables

For cabling specifications, refer to the following notes:

- [Cisco SFP and SFP+ Transceiver Module Installation Notes](#)
- [Cisco 40-Gigabit QSFP+ Transceiver Modules Installation Note](#)

Each port must match the wavelength specifications on the other end of the cable, and the cable must not exceed the stipulated cable length. Copper 1000BASE-T SFP module transceivers use standard four twisted-pair, Category 5 cable at lengths up to 328 feet (100 meters).

Cable Pinouts

Figure 74: Four Twisted-Pair Straight-Through Cable Schematic

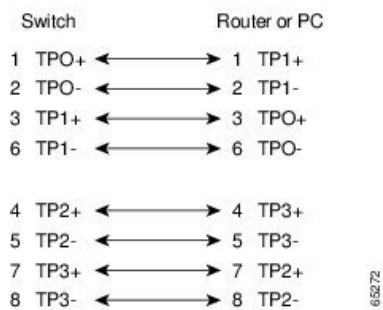

Figure 75: Four Twisted-Pair Semi-Cross Cable Schematic

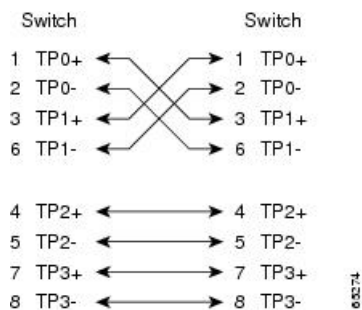

Figure 76: Two Twisted-Pair Straight-Through Cable Schematic

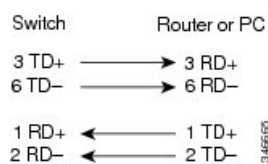
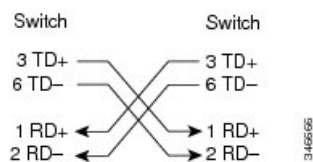

Figure 77: Two Twisted-Pair Crossover Cable Schematic



Identifying a Crossover Cable

To identify a crossover cable, compare the two modular ends of the cable. Hold the cable ends side-by-side, with the tab at the back. The wire connected to the pin on the outside of the left plug should be a different color from the wire connected to the pin on the inside of the right plug.

Figure 78: Identifying a Crossover Cable

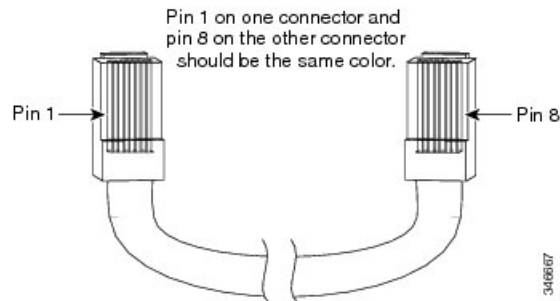

Console Port Adapter Pinouts

The RS-232 console port uses an 8-pin RJ-45 connector. Use an RJ-45-to-DB-9 adapter cable to connect the switch console port to a console PC. You need to provide a RJ-45-to-DB-25 female DTE adapter to connect the switch console port to a terminal.

Table 52: Console Port Signaling with a DB-9 Adapter

Switch Console Port (DTE)	RJ-45-to-DB-9 Terminal Adapter	Console Device
Signal	DB-9 Pin	Signal
TxD	2	RxD
GND	5	GND
GND	5	GND
RxD	3	TxD

Table 53: Console Port Signaling with a DB-25 Adapter

Switch Console Port (DTE)	RJ-45-to-DB-25 Terminal Adapter	Console Device
Signal	DB-25 Pin	Signal
TxD	3	RxD
GND	7	GND
GND	7	GND
RxD	2	TxD

