

## Cisco Business 250 Series Smart Switches Quick Start Guides

Cisco Business 250 Series Switches have different Quick Start Guides, depending on your product. Find your product SKU below to know which version of the Quick Start Guide to use.

### Quick Start Guide ([Pages 2-3](#))

CBS250-8T-E-2G	CBS250-24T-4G	CBS250-48P-4G
CBS250-8PP-E-2G	CBS250-24PP-4G	CBS250-24T-4X
CBS250-8P-E-2G	CBS250-24P-4G	CBS250-24P-4X
CBS250-8FP-E-2G	CBS250-24FP-4G	CBS250-24FP-4X
CBS250-16T-2G	CBS250-48T-4G	CBS250-48T-4X
CBS250-16P-2G	CBS250-48PP-4G	CBS250-48P-4X

### Quick Start Guide ([Pages 4-5](#))

CBS250-8T-D	CBS250-8PP-D
-------------	--------------



# Cisco Business 250 Series Smart Switches



Thank you for choosing the Cisco 250 Series Switch. These switches are designed to be operational right out of the box as standard switches. In the default configuration, the switch forwards packets between the connected devices after powering up.

## Product Features

- 1 System LED
- 2 Reset Button
- 3 Mini USB Console Port
- 4 USB Port
- 5 RJ45 Console Port
- 6 LINK/ACT LEDs
- 7 Gigabit Network Ports
- 8 SFP/SFP+ Uplink Ports

## What's in the Box

- Cisco Business 250 Series Smart Switch
- Power Cord or Adapter
- Rack-Mount/Wall-Mount Kit
- Quick Start Guide
- Pointer Card with China RoHS
- Technical Support Contacts

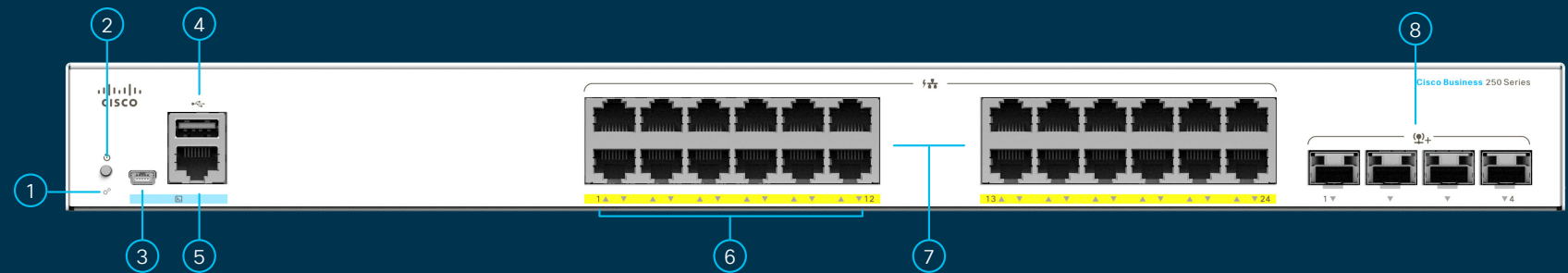

## First, You'll Need...

- RJ-45 Ethernet cables (Category 5e or higher) for connecting network devices
- Tools for mounting the hardware
- Computer with an Ethernet port (or adapter) and a web browser (Firefox, Chrome, Safari, or Edge)
- A mobile device with Wi-Fi capability (to set up using the mobile app)

## Get Connected

Plug the power cord of the switch into an outlet.

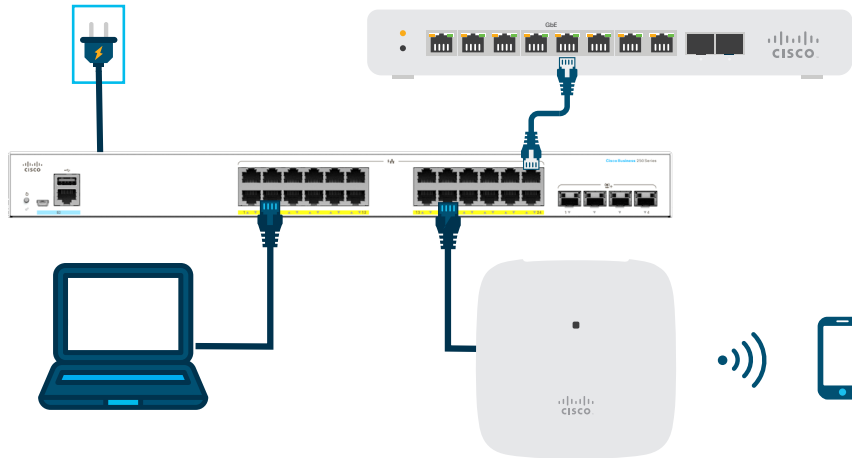

## Preparing Your Switch

**Using the Mobile app:** Connect the switch to an existing wireless network. This could be a wireless access point (shown above), wireless router, or mesh extender. You will need something to act as your DHCP server (a router or switch as shown above). Once connected, proceed to the “Get Configured” section to download the app.

**Using the Web User Interface (UI):** Connect a computer to one of the switch ports with an Ethernet cable. Make sure your computer is on and proceed to the Web UI Setup instructions under the “Get Configured” section.

## LED Functions

LED	GREEN STEADY	GREEN FLASHING	AMBER	OFF
System	Switch has acquired an IP address through DHCP or a static IP address has been manually configured.	Booting, performing self-tests, acquiring IP address, or factory default IP address is being used.	Flashing, hardware failure detected.	Switch is powered off.
LINK/ACT	Link between corresponding port and another device detected.	Port is passing traffic.		Link down.

## Get Configured

### Download the Cisco Business Mobile app



Scan the QR code here to download the app or go to [cisco.com/go/cbsapp](https://cisco.com/go/cbsapp) and follow the installation instructions.

### Alternative: Web UI Setup

- The switch will attempt to acquire an IP address if there is a DHCP server in the network. If the switch cannot acquire an IP address through DHCP, it uses the factory default IP address of 192.168.1.254, with a subnet mask of /24.
  - If the switch is using the factory default IP address of 192.168.1.254/24, you must choose an IP address for the computer in the range of 192.168.1.2-192.168.1.253 that is not already in use.
- Open a web browser window.
- Enter the switch IP address in the address bar and press **Enter**. For example, <http://192.168.1.254>. The **Switch Login Page** displays.
- Enter the default login information:
  - Username is **cisco**
  - Default password is **cisco** (passwords are case-sensitive)
- Click **Log In**.

You are now ready to configure the switch. Refer to the Administration Guide for further information.

## Mounting

For detailed mounting instructions, please see the “**Get Support**” section.

## Get Support



For Cisco support and additional documentation, including mounting instructions and the Administration Guide, visit <https://cisco.com/go/cbs250>.



# Cisco Business 250 Series Smart Switches



Thank you for choosing the Cisco Business 250 Series Switch. These switches are designed to be operational right out of the box as standard switches. In the default configuration, the switch forwards packets between the connected devices after powering up.

## What's in the Box

- Cisco Business 250 Series Switch
- Power Cord or Adapter
- Wall-Mount Kit
- Quick Start Guide
- Pointer Card with China RoHS
- Technical Support Contacts

## Product Features

- 1 Reset Button
- 2 System LED
- 3 Link/ACT LEDs
- 4 PoE (Power over Ethernet) LEDs\*

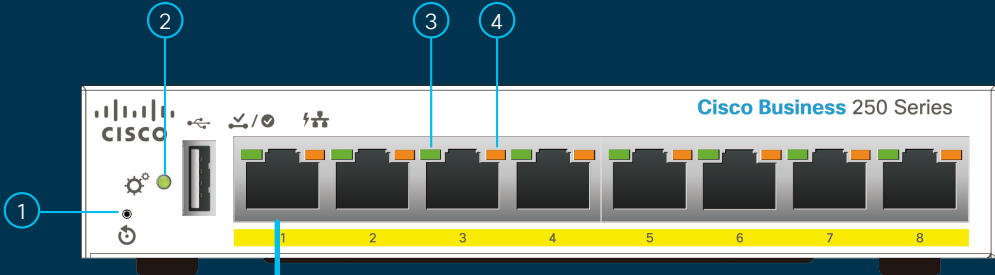

NOTE: On the CBS250-8T-D model, port 1 can work as a PoE PD or PoE input port to power the switch.



## First, You'll Need...

- RJ-45 Ethernet cables (Category 5e or higher) for connecting network devices
- Tools for mounting the hardware
- Computer with an Ethernet port (or adapter) and a web browser (Firefox, Chrome, Safari, or Edge)
- A mobile device with Wi-Fi capability (to set up using the mobile app)

\* PoE product shown. For non-PoE products there is a Gigabit LED instead of a PoE LED.

## Get Connected

Plug the power cord of the switch into an outlet.

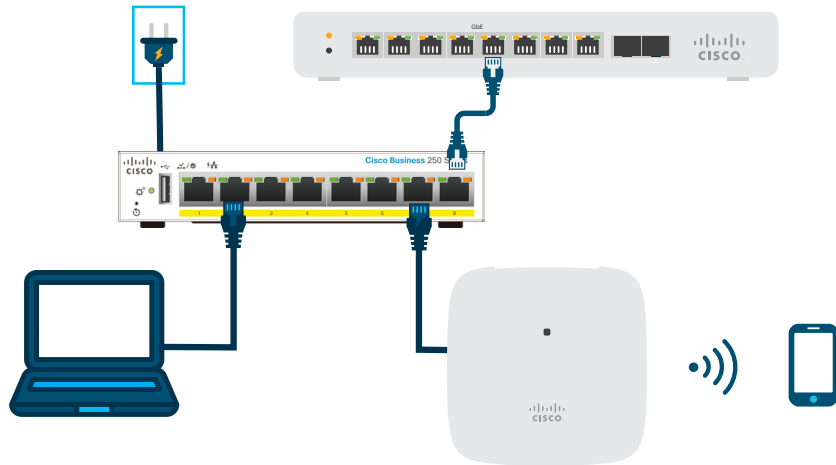

## Preparing Your Switch

**Using the Mobile app:** Connect the switch to an existing wireless network. This could be a wireless access point (shown above), wireless router, or mesh extender. You will need something to act as your DHCP server (a router or switch as shown above). Once connected, proceed to the “Get Configured” section to download the app.

**Using the Web User Interface (UI):** Connect a computer via Ethernet cable to one of the switch ports. Make sure your computer is on and proceed to Web UI Setup instructions under the “Get Configured” section.

## LED Functions

LED	GREEN STEADY	GREEN FLASHING	AMBER	OFF
System	Switch has acquired an IP address through DHCP or a static IP address has been manually configured.	Booting, performing self-tests, acquiring IP address, or factory default IP address is being used.	Flashing, hardware failure detected.	Switch is powered off.
LINK/ACT	Link between corresponding port and another device detected.	Port is passing traffic.		Link down.
PoE*			Steady Power is being supplied to a device connected to the port.	Power is not being supplied or nothing is connected to the port.
Gigabit*	1000Mbps link is established.			Connection speed is under 1000Mbps or nothing is connected to the port.

\* Depending on model. PoE switches will only have a PoE LED whereas non-PoE switches will have a Gigabit LED.

## Get Configured

### Download the Cisco Business Mobile app



Scan the QR code here to download the app or go to [cisco.com/go/cbsapp](https://cisco.com/go/cbsapp) and follow the installation instructions.

### Alternative: Web UI Setup

- The switch will attempt to acquire an IP address if there is a DHCP server in the network. If the switch cannot acquire an IP address through DHCP, it uses the factory default IP address of 192.168.1.254, with a subnet mask of /24.
  - If the switch is using the factory default IP address of 192.168.1.254/24, you must choose an IP address for the computer in the range of 192.168.1.2-192.168.1.253 that is not already in use.
- Open a web browser window.
- Enter the switch IP address in the address bar and press **Enter**. For example, <http://192.168.1.254>. The **Switch Login Page** displays.
- Enter the default login information:
  - Username is **cisco**
  - Default password is **cisco**  
(passwords are case-sensitive)
- Click **Log In**.

You are now ready to configure the switch. Refer to the Administration Guide for further information.

## Mounting

For detailed mounting instructions, please see the “**Get Support**” section.

## Get Support



For Cisco support and additional documentation, including mounting instructions and the Administration Guide, visit <https://cisco.com/go/cbs250>.

©2021 Cisco and/or its affiliates. All rights reserved. Cisco and the Cisco logo are trademarks or registered trademarks of Cisco and/or its affiliates in the U.S. and other countries. To view a list of Cisco trademarks, go to this URL: <https://www.cisco.com/go/trademarks>. Third-party trademarks mentioned are the property of their respective owners. The use of the word partner does not imply a partnership relationship between Cisco and any other company. (1110R)