

CITIZEN

LINE THERMAL PRINTER

MODEL CL-E300/CL-E303 User's Manual

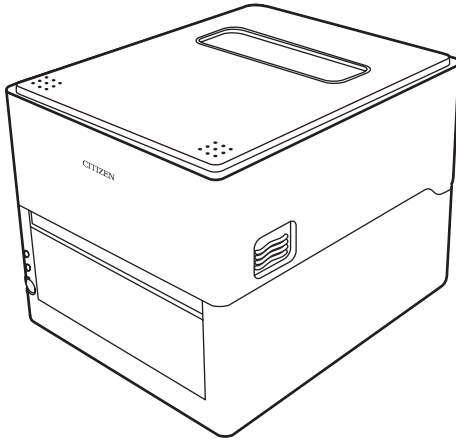

CITIZEN SYSTEMS JAPAN CO., LTD.

WEEE MARK

En

If you want to dispose of this product, do not mix it with general household waste. There is a separate collection systems for used electronics products in accordance with legislation under the WEEE Directive (Directive 2002/96/EC) and is effective only within European Union.

Ge

Wenn Sie dieses Produkt entsorgen wollen, dann tun Sie dies bitte nicht zusammen mit dem Haushaltsmüll. Es gibt im Rahmen der WEEE-Direktive innerhalb der Europäischen Union (Direktive 2002/96/EC) gesetzliche Bestimmungen für separate Sammelsysteme für gebrauchte elektronische Geräte und Produkte.

Fr

Si vous souhaitez vous débarrasser de cet appareil, ne le mettez pas à la poubelle avec vos ordures ménagères. Il existe un système de récupération distinct pour les vieux appareils électroniques conformément à la législation WEEE sur le recyclage des déchets des équipements électriques et électroniques (Directive 2002/96/EC) qui est uniquement valable dans les pays de l'Union européenne.

Les appareils et les machines électriques et électroniques contiennent souvent des matières dangereuses pour l'homme et l'environnement si vous les utilisez et vous vous en débarrassez de façon inappropriée.

Sp

Si desea deshacerse de este producto, no lo mezcle con residuos domésticos de carácter general. Existe un sistema de recogida selectiva de aparatos electrónicos usados, según establece la legislación prevista por la Directiva 2002/96/CE sobre residuos de aparatos eléctricos y electrónicos (RAEE), vigente únicamente en la Unión Europea.

It

Se desiderate gettare via questo prodotto, non mescolatelo ai rifiuti generici di casa. Esiste un sistema di raccolta separato per i prodotti elettronici usati in conformità alla legislazione RAEE (Direttiva 2002/96/CE), valida solo all'interno dell'Unione Europea.

Du

Deponer dit product niet bij het gewone huishoudelijk afval wanneer u het wilt verwijderen. Er bestaat ingevolge de WEEE-richtlijn (Richtlijn 2002/96/EG) een speciaal wettelijk voorgeschreven verzamelstelsel voor gebruikte elektronische producten, welk alleen geldt binnen de Europese Unie.

Da

Hvis du vil skille dig af med dette produkt, må du ikke smide det ud sammen med dit almindelige husholdningsaffald. Der findes et separat indsamlingsystem for udtjente elektroniske produkter i overensstemmelse med lovgivningen under WEEE-direktivet (direktiv 2002/96/EC), som kun er gældende i den Europæiske Union.

Por

Se quiser deitar fora este produto, não o misture com o lixo comum. De acordo com a legislação que decorre da Directiva REEE – Resíduos de Equipamentos Eléctricos e Electrónicos (2002/ 96/ CE), existe um sistema de recolha separado para os equipamentos electrónicos fora de uso, em vigor apenas na União Europeia.

Pol

Jeżeli zamierzasz pozbyć się tego produktu, nie wyrzucaj go razem ze zwykłymi domowymi odpadkami. Według dyrektywy WEEE (Dyrektywa 2002/96/EC) obowiązującej w Unii Europejskiej dla używanych produktów elektronicznych należy stosować oddzielne sposoby utylizacji.



Compliance Statement for European Users

CE marking shows conformity to the following criteria and provisions:

Low Voltage Directive (2014/35/EU), EMC Directive (2014/30/EU), and RoHS directive (2011/65/EU)

Full text of the EU declaration of conformity is available at the following internet address:

http://www.citizen-systems.co.jp/english/support/download/printer/others/eu_doc/

FCC Compliance Statement for American Users

FCC Related Information

This equipment has been tested and found to comply with the limits for a **Class B** digital device, pursuant to Part 15 of the FCC Rules.

These limits are designed to provide reasonable protection against harmful interference in a residential installation. This equipment generates, uses and can radiate radio frequency energy and, if not installed and used in accordance with the instructions, may cause harmful interference to radio communications.

However, there is no guarantee that interference will not occur in a particular installation. If this equipment does cause harmful interference to radio or television reception, which can be determined by turning the equipment off and on, the user is encouraged to try to correct the interference by one or more of the following measures:

- Reorient or relocate the receiving antenna.
- Increase the separation between the equipment and receiver.
- Connect the equipment into an outlet on a circuit different from that to which the receiver is connected.
- Consult the dealer or an experienced radio/TV technician for help.

Pursuant to FCC regulations, you are cautioned that any changes or modifications not expressly approved in this manual could void your authority to operate this equipment.

Sicherheitshinweis

Die Steckdose zum Anschluß dieses Druckers muß nahe dem Gerät angebracht und leicht zugänglich sein.

EMI Compliance Statement for Canadian Users

This **Class B** Information Technology Equipment (ITE) complies with Canadian CAN ICES-3(B)/NMB-3(B).

This equipment generates and uses radio frequency energy and if not installed and used properly, that is, in strict accordance with the manufacturer's instructions, may cause interference to radio and television reception. This Information Technology Equipment (ITE) does not exceed the **Class B** limits for radio noise emissions from digital apparatus set out in the Radio Interference Regulations of the Canadian Department of Communications. This equipment is designed to provide reasonable protection against such interference in a residential installation.

However, there is no guarantee that interference will not occur in a particular installation. If this equipment does cause interference to radio or television reception, which can be determined by turning the equipment off and on, the user is encouraged to try to correct the interference by one or more of the following measures:

- Reorient or relocate the receiving antenna.
- Increase the separation between the equipment and receiver.
- Connect the equipment into an outlet on a circuit different from that to which the receiver is connected.
- Consult the dealer or an experienced radio/TV technician for help.

État de conformité EMI à l'usage des utilisateurs Canadiens

Cet Équipement informatique (EI) de la **classe B** est conforme à la norme CAN ICES-3(B)/NMB-3(B) du Canada.

Cet équipement produit et utilise l'énergie à radiofréquences et s'il n'est pas installé et utilisé correctement, c'est à dire en accord strict avec les instructions du fabricant, il risque de provoquer des interférences avec la réception de la radio et de la télévision.

Le présent Équipement informatique (EI) n'émet pas de bruits radio électriques dépassant les limites applicables aux appareils numériques de la **classe B** prescrites dans le Règlement sur le brouillage radioélectrique édicté par le ministère des Communications du Canada.

Cet équipement est conçu pour fournir une protection satisfaisante contre de telles interférences dans une installation résidentielle.

Cependant, il n'y a pas de garantie contre les interférences avec les réceptions radio ou télévision, provoquées par la mise en et hors circuit de l'équipement; aussi, il est demandé à l'utilisateur d'essayer de corriger l'interférence par l'une ou plus des mesures suivantes:

- Réorienter l'antenne de réception.
- Installer l'ordinateur ailleurs, par rapport au récepteur.
- Brancher l'ordinateur dans une prise de courant différente de façon à ce que l'ordinateur et le récepteur soient branchés sur des circuits différents.
- Consulter le revendeur ou un technicien radio/ TV expérimenté pour toute assistance.

GENERAL PRECAUTIONS

- Before using this product, be sure to read through this manual. After having read this manual, keep it in a safe, readily accessible place for future reference.
 - The information contained herein is subject to change without prior notice.
 - Reproduction or transfer of part or all of this document in any means is prohibited without permission from Citizen Systems.
 - Note that Citizen Systems is not responsible for any operation results regardless of omissions, errors, or misprints in this manual.
 - Note that Citizen Systems is not responsible for any trouble caused as a result of using options or consumables that are not specified in this manual.
 - Except explained elsewhere in this manual, do not attempt to service, disassemble, or repair this product.
 - Citizen Systems Japan Co., Ltd. shall not be liable for damages caused by improper or incorrect usage or by the usage environment.
 - Data is basically for temporary use and not stored for an extended period of time or permanently. Please note that Citizen Systems is not responsible for damage or lost profit resulting from the loss of data caused by accidents, repairs, tests or other occurrences.
 - If you find omissions, errors, or have questions, please contact your Citizen Systems dealer.
-
- CITIZEN is a registered trademark of Citizen Watch Co., Ltd.
 - QR Code is a registered trademark of DENSO WAVE INCORPORATED.
 - Datamax® is a registered trademark of Honeywell International Inc.
 - Maxi Code is a registered trademark of UPS.
 - Zebra® and ZPL2® are registered trademarks of Zebra Technologies, Inc. in the U.S.
 - PDF417 is a trademark or registered trademark of Motorola, Inc. in the U.S. and other countries.
 - TrueType™ is a trademark of Apple Inc.
 - All other trademarks are the property of their respective owners.
 - Citizen Systems use these trademarks in accordance with the license of relevant owners.

Copyright© CITIZEN SYSTEMS JAPAN CO., LTD. 2017

SAFETY PRECAUTIONS...WHICH SHOULD BE STRICTLY OBSERVED

Before using this product for the first time, carefully read these SAFETY PRECAUTIONS. Improper handling may result in accidents (fire, electric shock or injury). In order to prevent injury to operators, third parties, or damage to property, special warning symbols are used in the User's Manual to indicate important items to be strictly observed.

- After having read this Manual, keep it in a safe, readily accessible place for future reference.
- Some of the descriptions contained in this manual may not be relevant to some printer models.

The following describes the degree of hazard and damage that could occur if the printer is improperly operated by ignoring the instructions indicated by the warning symbols. Be sure to read this information carefully.



WARNING

Neglecting precautions indicated by this symbol may result in fatal or serious injury.



CAUTION

Neglecting precautions indicated by this symbol may result in injury or damage to property.



This symbol is used to alert your attention to important items.

Warnings



- **Do not perform any of the following actions as they may result in damage or malfunction of the device, overheating, the generation of smoke, fire, or electric shock. If the device is damaged or defective, turn off the power, disconnect the power plug from the electrical outlet, and contact your retailer.**
- Do not step on, drop, hit, or otherwise subject the device to significant force or impact.
- Do not use the device in environments of poor ventilation or in a manner that blocks device vents.
- Do not use the device in environments, such as laboratories, where chemical reactions occur or environments exposed to air that contains salt or toxic gases.
- Use the device in environments at specified power supply voltage and frequency (100 to 240 V and 50/60 Hz).
- Do not connect or disconnect the power cord or an interface cable by holding the cable itself. Do not pull or carry the device while cables are under load.
- Do not drop or insert small objects such as clips or push-pins into the device.
- Do not connect too many power cords to a single electrical outlet.
- Do not spill tea, coffee, juice, or other beverages onto the device. Do not subject the device to insecticides. If liquid is spilled onto the device, turn off the power, disconnect the power plug from the electrical outlet, and contact your retailer.
- Do not disassemble or modify the device.
- Do not use non-specified AC adapters.
- Use only the included power cord. Do not use the included power cord with other devices.
- Do not use deformed or damaged power cords.
- Do not unnecessarily process power cords.
- **Exposed wire due to damaged power cords or melted sheaths may cause current leakage, malfunction, or electric shock. Contact your retailer if the power cord becomes damaged.**
- Do not place objects around the power plug.

General Precautions

Observe these precautions to ensure proper use of the device. Make sure to read these precautions.



CAUTION

- Do not touch the area around the thermal head during or right after the printing process. This area will be hot and may cause burns.
- Do not drop or insert small objects such as clips or pins into the printer. Doing so may result in failure.
- Exercise caution when carrying or transporting the device. Dropping the device may damage other objects or cause injury.
- Make sure to open the printer cover fully when it needs to be opened. Failure to do so may result in the printer closing unexpectedly, which may cause injury.
- Exercise caution when the printer cover is open. Contact with edges may result in injury.
- Do not open the printer cover while the printer is printing.
- Do not use thinner, trichlene, benzene, ketone-based solvents, or cleaning cloths with chemicals to clean the case surface.
- Do not use the device in environments exposed to significant levels of oil, metal shavings, waste, and dust.
- Do not spill liquids onto the device or expose the device to spray chemicals.
- Do not step on, drop, hit, or otherwise subject the device to significant force or impact.
- Make sure to use the control panel correctly. Pressing buttons randomly may cause malfunction and even failure. Do not use sharp objects including tips of pens to operate the control panel.
- If some abnormality occurs during use, immediately stop using the device and disconnect the power plug from the electrical outlet.
- Do not disassemble the device for repairs in case of failure. Always contact the dealer for repairs.
- The auto cutter has internal blades near the media discharge port. Never insert hands inside the media discharge port whether the printer is operating or not.

Installation Precautions



CAUTION

- Do not use or store the device in environments exposed to excessive heat, moisture, direct sunlight, near heaters, extremely high or low altitudes, excessive humidity, or excessive dust.
- Do not use the device in environments, such as laboratories, where chemical reactions occur.
- Do not use the device in environments exposed to air that contains salt or toxic gases.
- Place printers on level, stable surfaces in environments with good ventilation. (Do not place the printer such that the vents are against walls.)
- Do not place objects on top of the device.
- Using the device near radios or televisions or plugging the power cord into the same electrical outlet as used by such devices may cause reception interference.
- Use the device in environments at specified power supply voltage and frequency.
- Use only the included power cord. Do not use the included power cord with other devices.
- Do not place objects or step on power cords.
- Do not pull or attempt to carry the device by the power cord or an interface cable.
- Do not connect too many power cords to a single electrical outlet.
- Do not bundle the power cord.
- Hold the power cord by the power plug to connect and disconnect to/from electrical outlets.
- Ensure connectors are properly connected. In particular, reversing the polarity may damage internal parts.
- Turn the power switch off before connecting or disconnecting interface cables.
- Do not run long signal lines or make connections with noisy devices to the extent possible. If necessary, use shielded twisted pair cables for signal lines and take any other necessary steps to ensure signal integrity.
- Place the device near an electrical outlet and ensure that the power plug can be unplugged easily so that the power to the device can be cut quickly if necessary.
- Use electrical outlets with ground terminal screws. Using electrical outlets without ground terminals may result in injury due to static electricity.

PRECAUTIONS IN HANDLING THE PRINTER

CAUTION

Caution label is attached in the position shown in the following figure. Carefully read the handling precautions before using the printer.

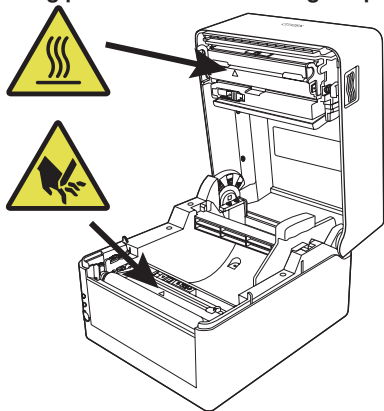

These labels indicate that the head becomes hot, so touching it may cause burns, and touching the auto cutter and manual cutter when opening the paper cover may cause cuts on hands.

THE TABLE OF CONTENTS

1. GENERAL OUTLINE	13
1.1 Features	13
1.2 Unpacking	15
1.3 Model Classification	16
2. Part Names and Function	18
2.1 Front of Printer.....	18
2.2 Operation panel.....	20
2.3 Rear of Printer	21
2.4 Inside of Printer	23
3. SETUP.....	25
3.1 Printing Preparation Process.....	25
3.2 Loading Paper	26
3.3 Adjusting Media Sensor Positions	33
3.4 Connecting the AC Adapter.....	35
3.5 Connecting the Printer to a Host Computer	36
3.6 Install the Printer Driver.....	38
4. Basic Operation	39
4.1 FEED Key Operation	39
5. Configuring Printer Settings Using the Specialized Utility.....	41
5.1 List of Settings.....	42
5.2 Obtaining the LabelPrinterUtility.....	47
5.3 Using the LabelPrinterUtility	47
6. Configuring Ethernet Network Settings	
Using Network Seeker	48
6.1 Starting Network Seeker	48
6.2 Changing Settings	49
7. Configuring Printer Settings Using a Browser	50
7.1 LinkServer user roles	50
7.2 LinkServer menu configuration.....	51
7.3 LinkServer connection procedure.....	52

8. Configuring the Printer Using the Operation Panel	54
8.1 Sensor Adjustment Mode	56
8.2 Test print mode	58
8.3 Configuration Print Mode.....	60
8.4 Emulation switching mode.....	61
8.5 HEX Dump Mode	62
8.6 Initialization Mode.....	63
9. Online Configuration Mode.....	65
10. Clearing Jobs Stored in the Printer	66
11. Maintenance	67
11.1 Plastic Surface of Printer and Platen.....	68
11.2 Thermal head	68
12. Appendices	69
12.1 Troubleshooting	69
12.2 Basic Specifications	70
12.3 Usage Conditions	78
12.4 Printer Storage Conditions	78
12.5 Interfaces.....	79

1. GENERAL OUTLINE

Thank you for purchasing the Citizen Systems Line Thermal Printer CL-E300/CL-E303. This printer is a line direct thermal printer developed for labels, tags, tickets, and many other applications.

1.1 Features

< Compact and Stylish Design >

- Boasting the smallest footprint in the industry, this printer was designed to be compact to free users from placement restrictions.
- The stylish design enables the device to be used in different environments.
- Exterior color options include black and pure white.

< High-speed, High-quality Printing >

- This printer utilizes the direct thermal method and a thermal print head and includes a 32-bit RISC CPU with a maximum operating frequency of 216 MHz and thermal history control to provide high-speed, high-quality performance up to 8 IPS with the CL-E300 model and up to 6 IPS with the CL-E303 model.

< Adjustable Sensors Provided as Standard >

- Adjustable media/black line sensors are provided as standard so that the detection position can be adjustable horizontally. This enables sensors to be placed at detection positions suitable for different types of media.

< Interface >

- Standard interfaces include a 9-pin, DSUB RS232C interface, full-speed USB 2.0 port, and an Ethernet port that supports 100BASE-TX and 10BASE-T. These interfaces enable high-speed connections to many peripheral devices.

< Excellent Usability >

- Manual media cutters are installed at the top and bottom of the media discharge port to cut media after being printed for better usability in many different environments.
- The operation panel has been designed to have a different color than the main exterior color for better visibility and stress-free operation.
- Thermal heads and platen rollers can be easily replaced without the use of tools.

< Easy to Use >



- Use the LabelPrinterUtility developed by Citizen to configure printer settings from a host computer.
- The built-in LinkServer™ printer tool can be used over Ethernet connections to change settings and perform other operations.
- Printer includes functionality to enable users to quickly adjust head balance.



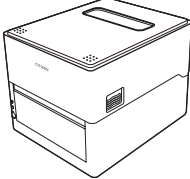
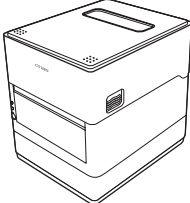
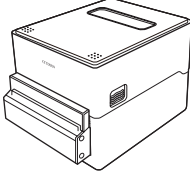
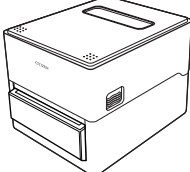

< Models equipped with cutters are optionally available >

- Models equipped with an auto cutter are also available.
- The types of auto cutter units available include the integrated fixed blade/adjustable blade type and the separable fixed blade/adjustable blade type.

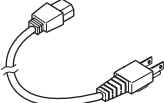
1.2 Unpacking

Make sure the following items are included with your printer.

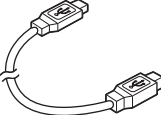
NAME	Exterior appearance
Printer	<p data-bbox="564 268 829 288">CL-E300X***NX (standard type)</p>  <p data-bbox="533 480 861 501">CL-E300X***NS (with AC adapter case)</p>  <p data-bbox="533 719 861 740">CL-E300X***BC (with integrated cutter)</p>  <p data-bbox="533 927 861 948">CL-E300X***PC (with separable cutter)</p> 
AC adapter	 <p data-bbox="505 1222 891 1243">*All models except the AC adapter case model</p>
AC cord	

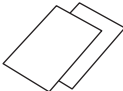
NAME	Exterior appearance
Media shaft guide	
Media shaft	
USB cable	
CD-ROM	
Quick Start Guide Safety Instructions	

1.3 Model Classification

Model numbers indicate printer features according to the following system.

CL - E300 X E B N N A

1
2
3
4
5
6
7

1. Model name
 CL-E300: 203 DPI
 CL-E303: 300 DPI
2. Fixed value
3. Market
 A: ASIA
 C: China
 E: Europe
 U: North America
4. Body case color
 B: Black
 W: Pure white
5. Interface
 N: USB port, Ethernet port, and RS-232C serial port

6. Cutter

N: None

BC: Integrated

PC: Separable

7. AC adapter

A: External type

S: Internal type

Certain combinations may not be available. Please contact us for inquiries on desired configurations.

2. Part Names and Function

2.1 Front of Printer

CL-E300X***NX (standard type)

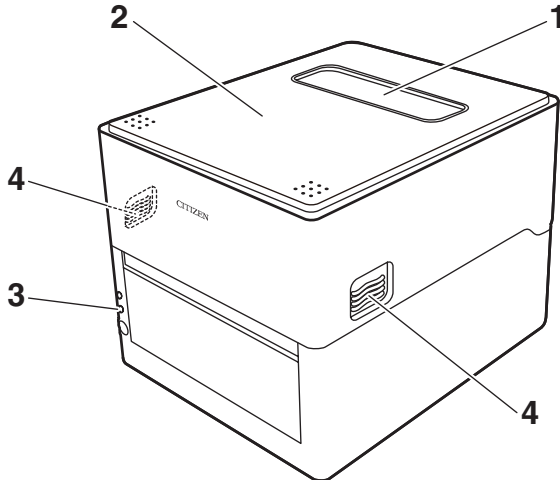

CL-E300X***NS (with AC adapter case)

*The figure illustrates the standard type with AC adapter case.

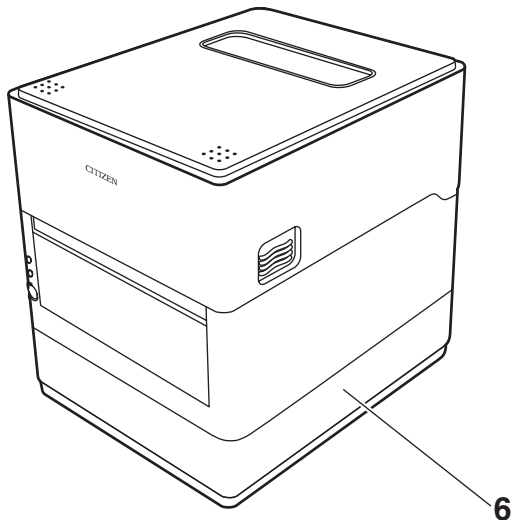

CL-E300X***BC (with integrated cutter)

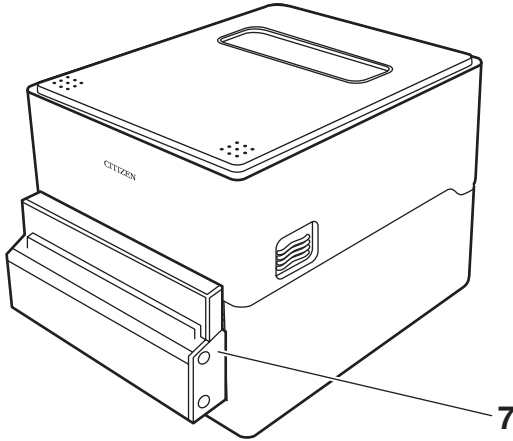

CL-E300X***PC (with separable cutter)

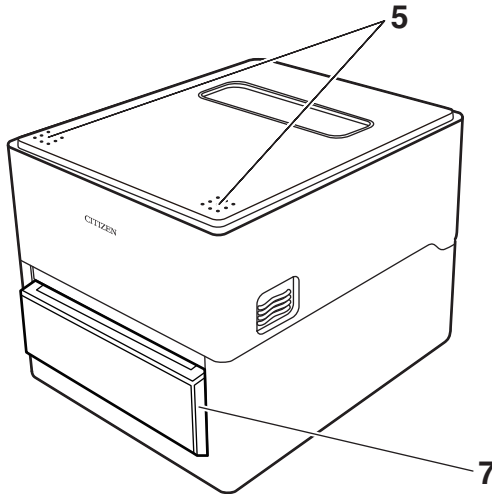

1. Top cover window
Enables users to check the media level.
2. Top cover
Opens upward so users can replace or set media.
3. Operation panel
Includes 2 LEDs and 1 key.
Enables users to perform different printer operations and check printer status.



Refer to 2.2 Operation panel

4. Cover release buttons
The cover is opened by pressing the buttons on both the right and left sides.
5. Push marks
6. AC adapter case
7. Auto cutter

2.2 Operation panel

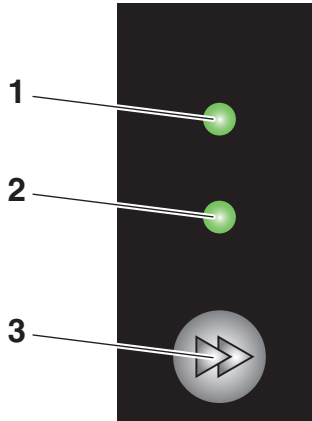

The operation panel includes 2 LEDs and 1 key.

1. Power LED
Turns on when the power is turned on and turns off when the power is turned off.
2. Status LED
Turns on or flashes in green, red, and amber depending on the printer status.

Color	Lights/ flashes	Status
Green	On	Printer is online
	Flashes	Receiving data
Amber	On	Startup
Red, green, amber	Flashes	Error or alarm
-	Off	Paused

3. FEED key
 - Feeds media when pressed while the printer is waiting to receive data.
 - Pressing and holding this key for at least 3 seconds changes the operation mode to the online configuration mode.



Refer to 9. Online Configuration Mode

- Turning on the power to the printer while pressing and holding the FEED key with the cover closed changes starts the printer in the special function mode.



Refer to 8. Configuring the Printer Using the Operation Panel

Other key operation varies depending on the currently selected mode. Refer to “FEED Key Operation” for more information.



Refer to 4.1 FEED Key Operation

2.3 Rear of Printer

CL-E300X***NX (standard type)

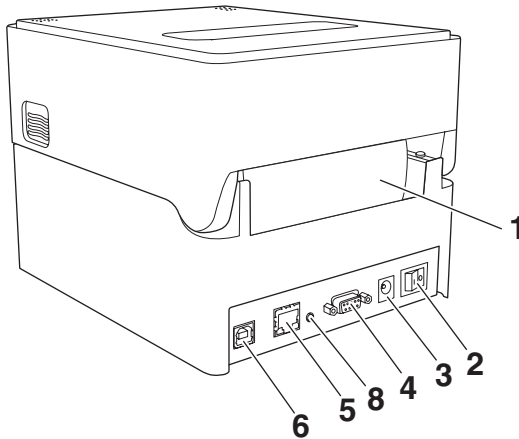

CL-E300X***NS (with AC adapter case)

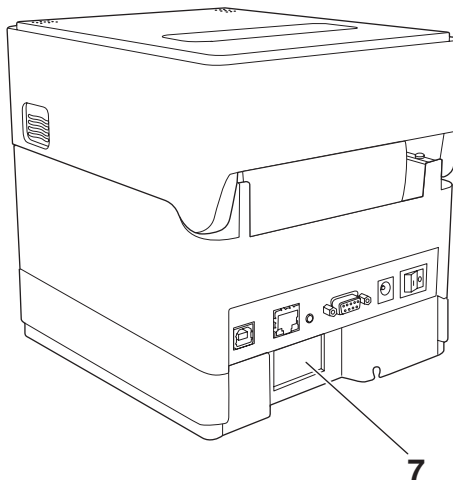

CL-E300X***BC (with integrated cutter)

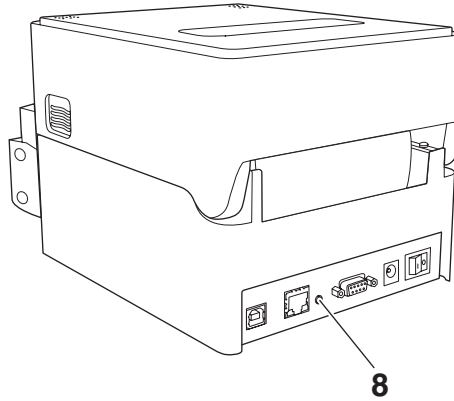

1. External media feed port
This port is used to feed media into the printer.
2. Power switch
Turns the printer power supply on and off.
3. DC jack
Connects to the included AC adapter.
4. D-SUB 9pin serial interface
5. USB interface
6. Ethernet Interface
7. AC port
8. Ethernet panel button
This button prints and initializes network settings.



CAUTION

Do not connect a USB cable to the Ethernet interface. Doing so may damage connectors/interfaces.

2.4 Inside of Printer

CL-E300X***NX (standard type)

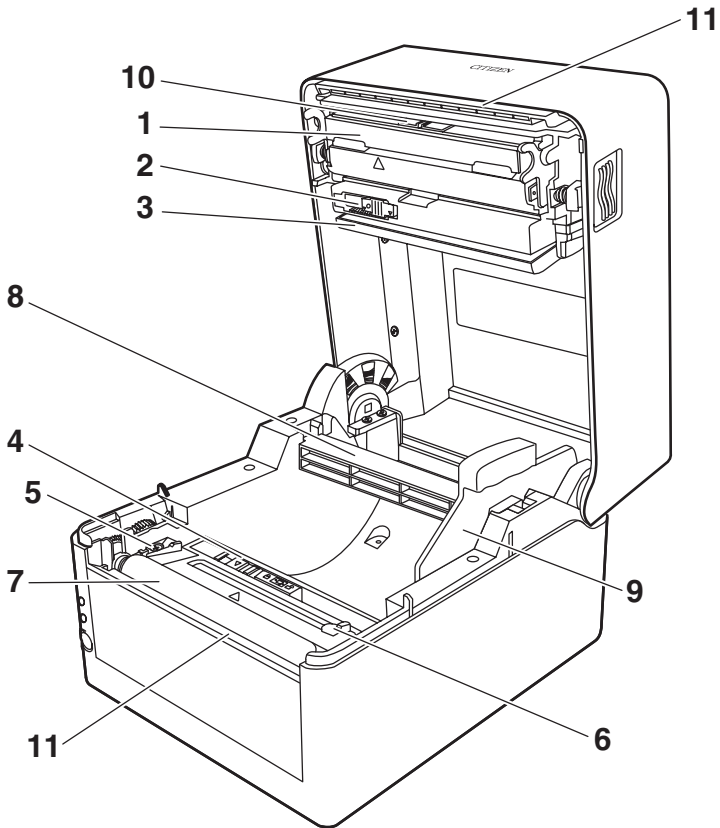

CL-E300X***BC (with integrated cutter)

CL-E300X***PC (with separable cutter)

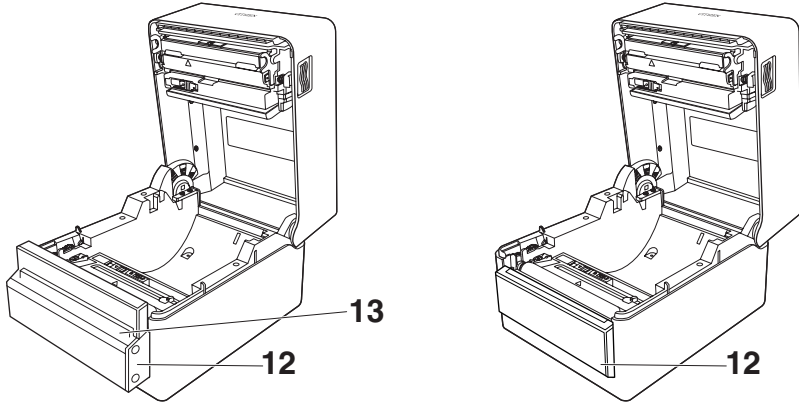

1. Thermal head
Prints characters and graphic data on paper (paper rolls).
2. Upper sensor
This sensor detects the media position.
3. Media damper
When using roll media, absorbs tension generated by media feed operations to prevent print errors.
4. Bottom sensor
This sensor detects the media position.
Devices are equipped with lock mechanisms.
5. Fixed left-side media guide
6. Adjustable right-side media guide
7. Platen roller
This roller transports media.
8. Media shaft
9. Media shaft guide
10. Head balance adjustment slider
11. Manual cutter (Upper/Bottom)
12. Auto cutter
13. Media discharge port

3. SETUP

3.1 Printing Preparation Process

The printer must be set up according to the following process before printing can be performed.

Refer to the description of each section for detailed information on each step of the process.

1. Unpack and check the package contents



Refer to 1.2 Unpacking

2. Physical installation

3. Loading Media



Refer to 3.2 Loading Paper

4. Adjusting Media Sensor Positions



Refer to 3.3 Adjusting Media Sensor Positions

5. Connecting the AC Adapter



Refer to 3.4 Connecting the AC Adapter

6. Connecting the Printer to a Host Computer



Refer to 3.5 Connecting the Printer to a Host Computer

7. Installing the Printer Driver onto the Host Computer



Refer to 3.6 Install the Printer Driver

8. Installing the Configuration Application onto the Host Computer



Refer to 5.2 Obtaining the LabelPrinterUtility

9. Printing

Use the Configuration Application installed on the Host Computer to print.

3.2 Loading Paper

1. Press the cover release buttons on both the right and left sides to open the top cover.



CAUTION

Note the following precautions when the top cover is open.

- Do not touch the thermal head.
- Do not touch the cutter blades.

2. Insert the media shaft through the core of the media roll and then install the media shaft guide.

- The media shaft is designed to accommodate both 1-inch and 1.5-inch media roll cores by flipping it upside down. The media shaft has markings indicating which side supports the different core sizes. Select the media shaft orientation in accordance with the size of the media roll core.

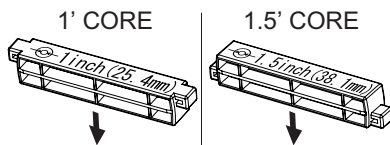

CAUTION

- Use media rolls that have the print surface on the outer side. Do not use media rolls that have the print surface on the inner side. Labels may peel when such media roll is back-fed.
- If the media shaft is not installed correctly, the top cover or bottom of the printer will prevent media from feeding properly and cause paper jams.

3. Set the media so that the media shaft guide is on the right side of the media when looking at the front of the printer.
4. Press the media shaft guide onto the media roll so that the center of the media aligns with the center of the media shaft and then set the media into the printer.
 1. Assemble the media shaft and media shaft guide.
 2. Insert the media shaft through the core of the media roll and then set the assembly into the printer.
 3. Set the media in the printer and slide the media to the left from the perspective of looking at the front of the printer. Insert the media shaft guide into the paper at this position.

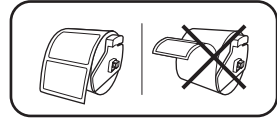
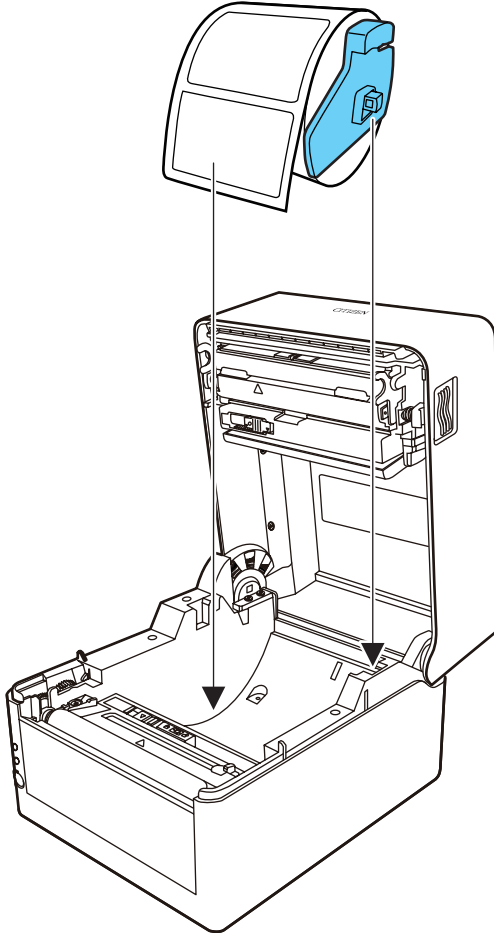

 **CAUTION**

Too much abutment force by media shaft guide may cause improper feeding of media, which may negatively impact print quality.

5. If using a model with the integrated fixed blade/adjustable blade type of cutter (CL-E300X***BC), insert the media through the cutter slit.

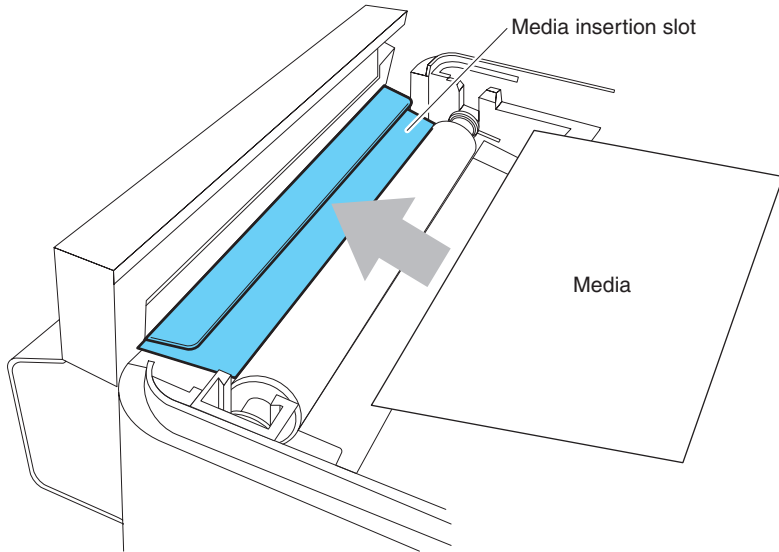

CAUTION

Insert media into the slit correctly. Failure to do so may result in improper feeding of media, which may cause paper jams.

6. Make sure the media is in abutment with the left media guide and then adjust the position of the right media guide in accordance with the media width.

From the front of the printer, set in front of the edge of media by approximately 10 mm.

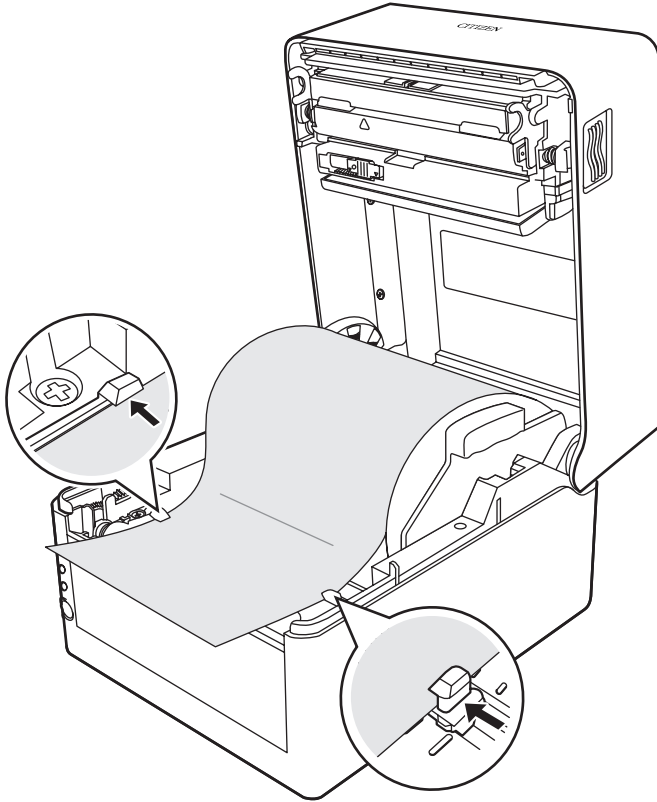

CAUTION

Too much abutment force of the right movable paper guide may cause improper feeding of media, which may negatively impact print quality.

7. Slide the head balance adjustment slider located near the thermal head along the media size scale (inch) so that the position of the notch in the slider matches the media width.

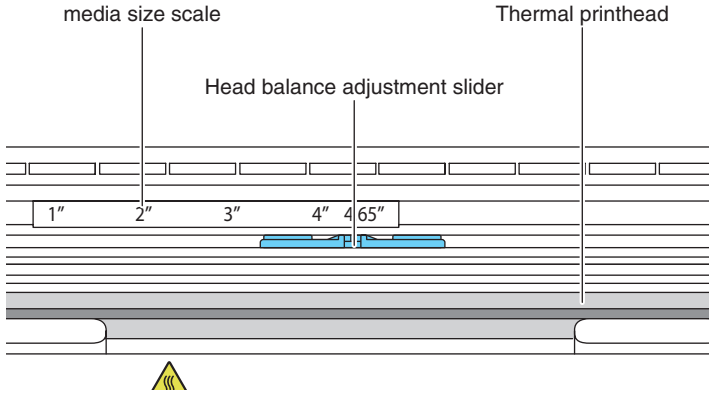

CAUTION

Adjust the head pressure horizontal balance carefully so as not to damage the thermal head. Damaged thermal heads will result in poor printing, paper jams, and malfunction.

7. Close the top cover.

CAUTION

Press the push marks on left and right sides at the top of the top cover and ensure that the top cover hooks on each side lock securely. If the top cover is not securely locked, this may cause print errors, paper jams, and malfunction.

Compatible Paper Types



CAUTION

Continuous label media cannot be used. Using such media may cause the label media adhesive to accumulate on cutter blades, which could result in failure.

Refer to the following specification table for information on the types of media compatible with this printer.

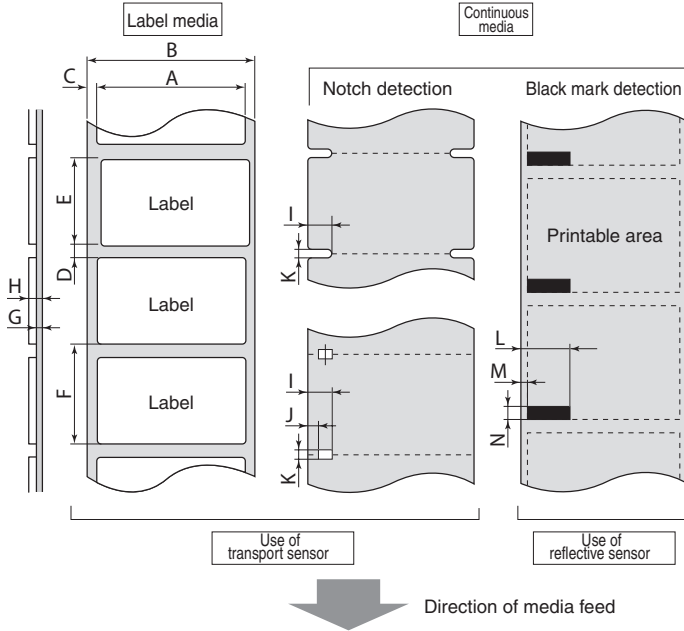

		Minimum value		Maximum value	
		mm	inch	mm	inch
A	Label width	21.50	0.83	118.00	4.65
B	Backing paper width	25.40	1.00	118.00	4.65
C	Left edge position of label	0	0	2.54	0.10
D	Label gap length	2.54	0.10	2,539.75 (CL-E300) 1,270.00 (CL-E303)	99.99 (CL-E300) 50.00 (CL-E303)
E	Label length	6.35	0.25	2,539.75 (CL-E300) 1,270.00 (CL-E303)	99.99 (CL-E300) 50.00 (CL-E303)
F	Label pitch	8.89	0.35	2,539.75 (CL-E300) 1,270.00 (CL-E303)	99.99 (CL-E300) 50.00 (CL-E303)
G	Backing paper thickness	0.06	0.0025	0.125	0.0049
H	Total media thickness (standard / integrated cutter)	0.06	0.0025	0.19	0.0075
	Total media thickness (separable cutter)	0.06	0.0025	0.15	0.0059
I	Notch right edge position	8.3	0.32	60.80	2.39
J	Notch left edge position	0	0	57.20	2.25
K	Notch length	2.54	0.10	17.80	0.70
L	Black line right edge position	15.00	0.59	66.50	2.62
M	Black line left edge position	0	0	51.50	2.02
N	Black line length	3.18	0.125	17.80	0.70

- Use the transmissive sensor when using media that has both gaps between labels and black lines.
- Use the transmissive sensor when using fanfold media.
- If the label pitch is 1 inch or less, configure an accurate label pitch with the [Small Label Printing] setting.
- Use carbon-based ink with an OD value of at least 1.5 to print black lines.

3.3 Adjusting Media Sensor Positions

This section describes the procedure to adjust sensors when loading media. Transmissive and reflective sensors can be used for the media sensors.

The printer comes from the factory equipped with a transmissive sensor. The media sensor must be replaced with a reflective sensor for certain types of media.



Refer to 8.1 Sensor Adjustment Mode

Range of Paper Sensor Adjustment

The following figure illustrates the range of media sensor adjustment.

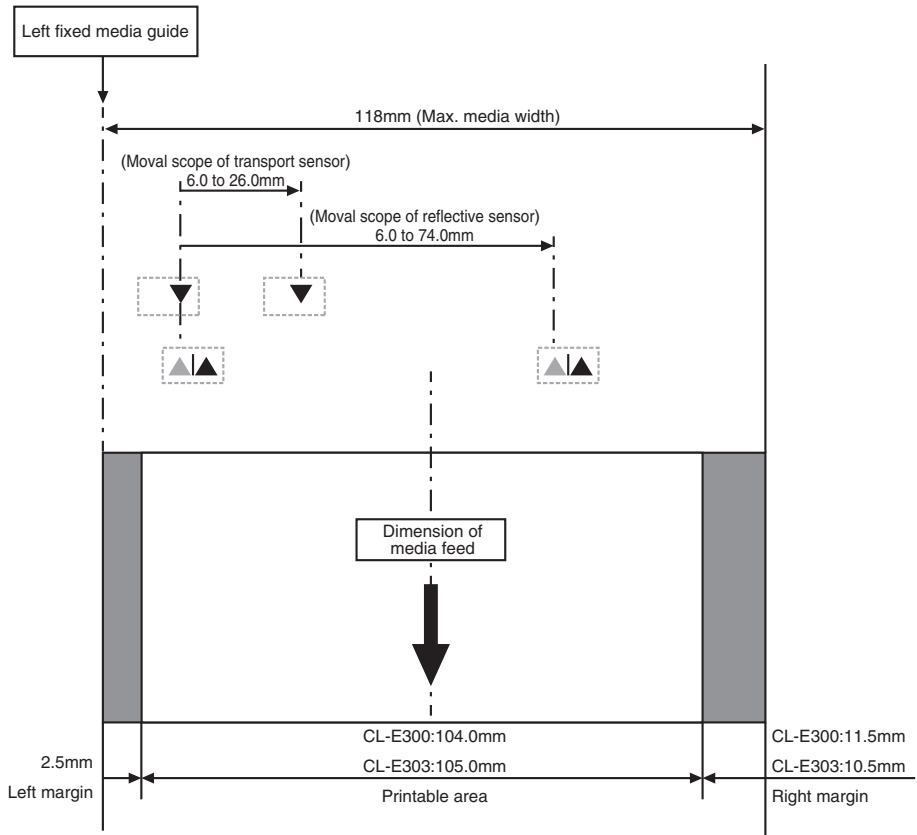

Transmissive Sensor Adjustment

- **Adjust the position of the bottom sensor and upper sensor in accordance with the media width.**

Move the bottom sensor and upper sensor by the same number of steps from the position of the triangle (▲).

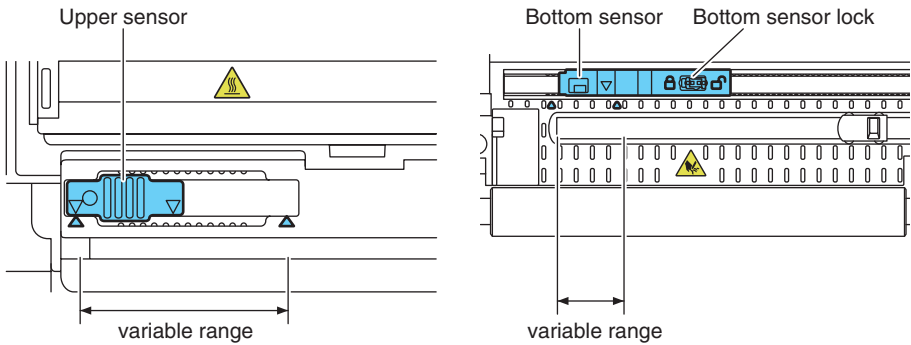

The range of bottom sensor and upper sensor horizontal adjustment is 10 steps between the triangle marks (▲).

Use a pen or other object with a narrow tip to unlock the bottom sensor and then reposition it. Lock the sensor in place once the new position has been determined.



CAUTION

- The bottom sensor and upper sensor must be in alignment with each other.
- Attempting to move the sensor while still locked may damage it.

Reflective Sensor Adjustment

- **Set the bottom sensor at a position so that the center of the sensor window is in alignment with the center of the black line.**

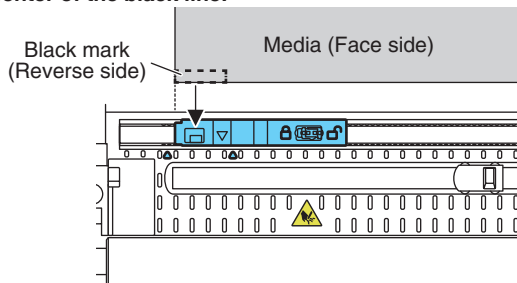

3.4 Connecting the AC Adapter

CAUTION

- Use the dedicated AC adapter designed for this device.
- Make sure the power switch on the printer is turned off before connecting the AC adapter.
- Insert the AC adapter connector completely into the DC jack.

1. Insert the DC plug on the output side of the AC adapter into the DC jack in the printer.
2. Insert the plug of the AC cord into an electrical outlet.

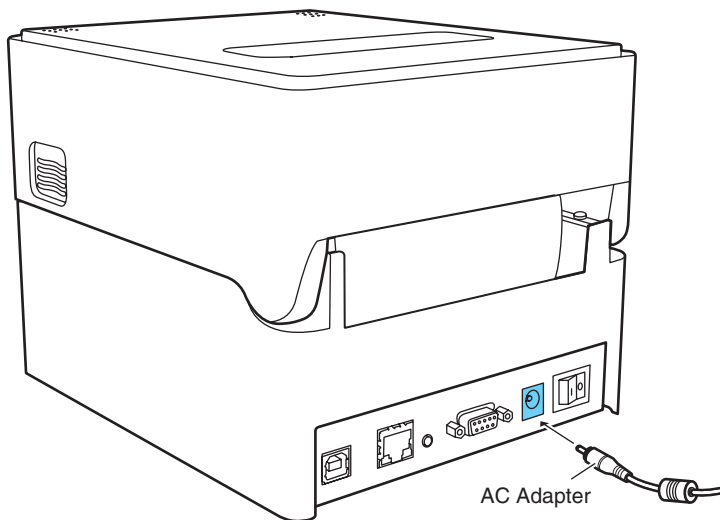

Models with the AC adapter case

- Insert the plug of the AC cord into the AC port.

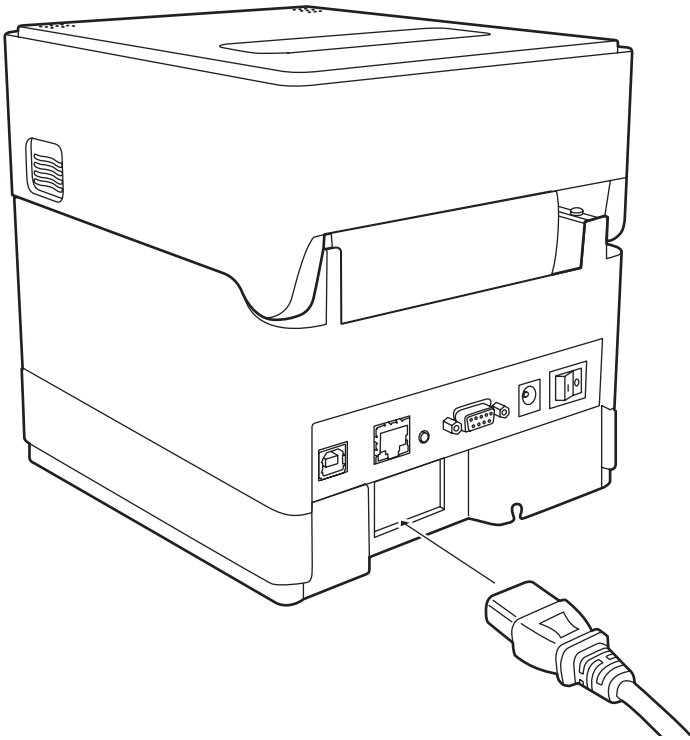

3.5 Connecting the Printer to a Host Computer

This printer is equipped with print data interfaces including a USB port, an Ethernet port, and a serial port.

Use the following procedure to connect this printer to a host computer.



CAUTION

Interface cables are required to connect the printer to a host computer.

1. Turn off the power to the printer and host computer.
2. Insert the cable into the appropriate interface port at the back of the printer.
Tighten any locking screws to secure the cable.

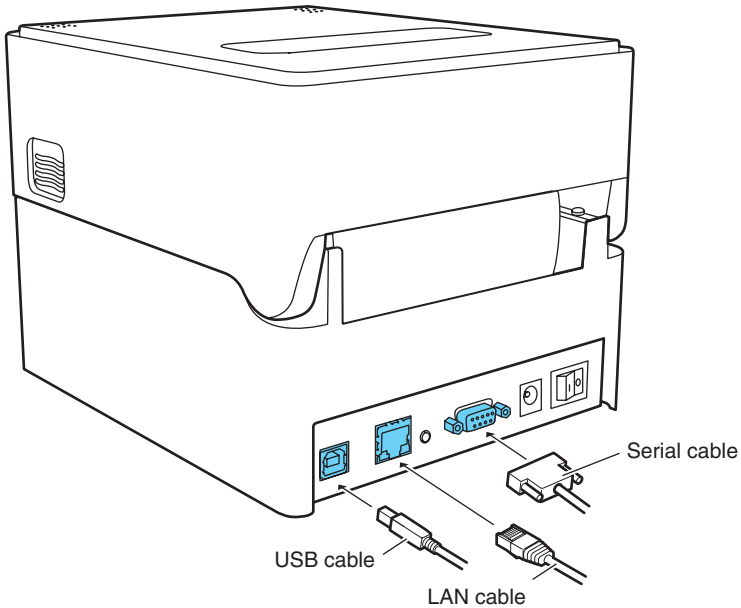

3. Insert the other end of the cable into the appropriate interface port in the host computer.
Tighten any locking screws to secure the cable.

Using an Ethernet connection

Configure network settings as necessary.



Refer to 6. Configuring Ethernet Network Settings Using Network Seeker



CAUTION

- To check the current Ethernet settings, press the Ethernet panel button located next to the Ethernet interface to printout the settings.
- To initialize Ethernet settings, press and hold the Ethernet panel button for at least 3 seconds. Once the buzzer emits a short tone, press and hold the Ethernet panel button again within 3 seconds for at least 3 seconds.

3.6 Install the Printer Driver

Install the printer driver onto the host computer.

Printer drivers are available for download from the Citizen Systems support website. The latest documentation, drivers, utilities, and other support information are also available from this website.

http://www.citizen-systems.co.jp/support/download/printer/label/index_en.html

Once a printer driver has been downloaded, follow the on-screen instructions to install the driver.

4. Basic Operation

- The “I” side of power switch on the back of the printer is the on side, and the “O” is the off side.

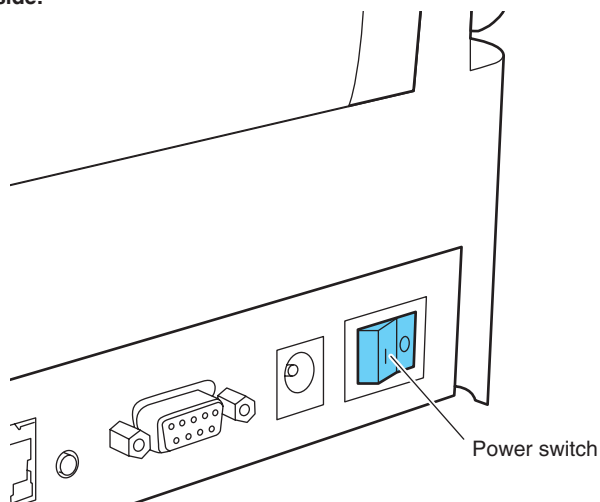

The power LED on the operation panel turns green after the power is turned on.

CAUTION

Stop printer operation before turning off the power.

4.1 FEED Key Operation

Online state (status LED is solid green)

- (1) Press the FEED key while the printer is not receiving data to feed media.
 - If label media is specified, the printer automatically stops after detecting the beginning of media. If continuous media is specified, the printer stops after a certain amount of feed operation.
 - If Tear off mode is selected in the Function Select setting, the printer feeds media to the tear-off position.
 - For models with a cutter, the printer will feed media to the cut position and then cut the media.
- (2) Press and hold the FEED key for at least 3 seconds while the printer is not receiving data to change the operation mode to the online configuration mode.



Refer to 9. Online Configuration Mode

Printing (status LED is solid or flashing in green)

Press the FEED key while the printer is printing or receiving data to pause the printer.

- The status LED turns off, and the printer pauses.
- If the FEED key is pressed while the printer is printing, the printer will finish printing the current label and then stop.

Press the FEED key again to resume printing operation for the remaining labels in the print job.

Paused (status LED is off)

Press and hold the FEED key to change to the clear job mode.



Refer to 10. Clearing Jobs Stored in the Printer

Error/alarm has occurred (status LED flashes in red, green, or amber)

Press the FEED key to clear the error or alarm.

5. Configuring Printer Settings Using the Specialized Utility

Use the LabelPrinterUtility configuration application to change printer settings.

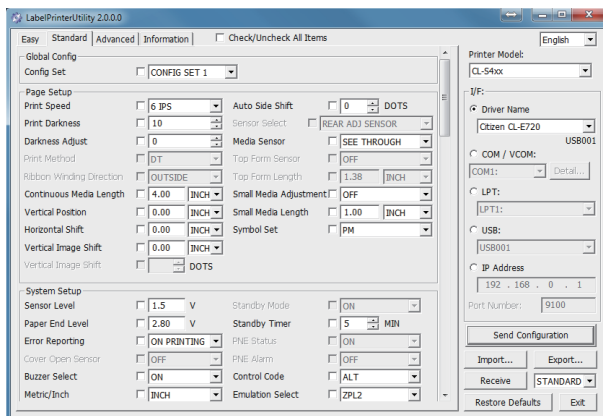

Refer to the following sections for more information on obtaining and using LabelPrinterUtility.



Refer to 5.2 Obtaining the LabelPrinterUtility



Refer to 5.3 Using the LabelPrinterUtility

5.1 List of Settings

This section describes the procedures to configure printer settings using the LabelPrinterUtility.

The following table lists the settings configurable with LabelPrinterUtility.

Home menu	Sub menu	Default	Configurable range	Notes
Page Setup - 1	Print Speed	6 IPS	CL-E300: 2 to 8 IPS CL-E303: 2 to 6 IPS	Sets the print speed
	Print Darkness	10	00 to 30	Adjusts the print density
	Darkness Adjust	00	-10 to 10	Fine adjustment of the density command
	Continuous Media Length	4.00 inch 101.6 mm	CL-E300: (Datamax) 0.25 to 99.99 inch 6.4 to 2539.7 mm (Zebra) 0.25 to 100.00 inch 6.4 to 2540.0 mm CL-E303: 0.25 to 50.00 inch 6.4 to 1,270.0 mm	Sets the length of continuous media The lower row shows millimeter values when using the printer in mm mode
	Vertical Position	0.00 inch 0.0 mm	-1.00 to 1.00 inch -25.4 to 25.4 mm	Adjusts the printing start position
	Horizontal Shift	0.00 inch 0.0 mm	-1.00 to 1.00 inch -25.4 to 25.4 mm	Adjusts the horizontal image position

Home menu	Sub menu	Default	Configurable range	Notes
Page Setup - 2	Vertical Image	(Datamax) 0.00 inch 0.0 mm	0.00 to 32.00 inch 0.0 to 812.8 mm	Adjusts the start position for creating images
		(Zebra) 000 dots	-120 to 120 dots	
	Auto Side Shift	0 dots	0 to 15 dots	Shifts the horizontal print position by the specified number of dots for each sheet/label. This is useful when significant load is placed on the portion of the thermal head, such as when printing vertical borders.
	Media Sensor	See Through	See Through Reflect None	Selects the type of label sensor type
	Small Media Adjustment	Off	On Off	Setting for small label support
	Small Media Length	1.00 inch 25.4 mm	0.25 to 1.00 inch 6.4 to 25.4 mm	Sets the length for small label media
Symbol Set	PM	50 options	Sets the character set	

Home menu	Sub menu	Default	Configurable range	Notes
System Setup - 1	Sensor Monitor	-	-	Displays the detection level of the currently selected sensor
	Sensor Level	1.5 V	0.0 V to 3.3 V	Sets the sensor threshold
	Paper End Level	3.00 V	0.01 V to 3.30 V	Sets the paper end level
	Error Reporting	On Printing	On Printing Immediate	Error reporting setting
	Buzzer Select	Exec/Err	Exec/Err All Error Key None	Sets the conditions at which the buzzer is triggered
	Metric/Inch	Inch	Inch mm	Sets the unit of measure
Max Media Length	10.00 inch 254.0 mm	CL-E300: (Datamax) 0.25 to 99.99 inch 6.4 to 2539.7 mm (Zebra) 0.25 to 100.00 inch 6.4 to 2540.0 mm CL-E303: 1.00 to 50.00 inch 25.4 to 1,270.0 mm	Sets the maximum length of label media	

Home menu	Sub menu	Default	Configurable range	Notes
System Setup - 2	Settings Lock	Off	On Off	Prevents changes via setting commands
	Keyboard Lock	Off	On Off	Prevents changes via key operation
	Control Code	STD	STD ALT ALT-2	Changes the command mode for DMX mode (only when Datamax® emulation is selected)
	Media Power Up	Off	On Off	Sets the media length measuring function when the power is turned on (only when Zebra® emulation mode is selected on international models)
	CI Lock	Off	On Off	Prevents changes via CI commands (only when Zebra® emulation mode is selected on international models)
	Emulation Select	DM4 (Datamax®) ZPI2 (Zebra®)	DM4 DMI DPP ZPI2	Datamax®/Zebra® compatibility selection DM4 Datamax® 400 DMI Datamax® IClass™ DPP Datamax® Prodigy Plus® ZPI2 Zebra® ZPL2®
	Emulation Auto Detect	Full Auto	On Off Full Auto	Sets the emulation sensing function (international models only)

Home menu	Sub menu	Default	Configurable range	Notes
After Print - 1	AutoConfigure	On	On Off	Enables/disables the auto configuration of optional equipment. On - Enables auto configuration (when a cutter is installed, mode is automatically configured regardless of the Function Select setting) Off - Disables auto configuration. Turn this setting Off and select operation with Function Select when you do not want to use the cutter if installed.
	Function Select	Tear	Off Tear Cut On(only valid for models with cutters)	Selects the operation mode when AutoConfigure is Off. Each option has a specified media stop position. Enables operation of the applicable device when selected. Also simultaneously emulates the parameter of the Prodigy Plus f command for each optional device.
	Cutter Action *Only valid for models with cutters	Backfeed	Backfeed Through	Cutter action setting Appears and prints only when AutoConfigure for models with cutters is On or when [Backfeed] is selected for the Function Select setting. The [Backfeed] option performs a back-feed after each cut operation. The [Through] option continues the print operation at the trailing edge of each sheet/label from the first sheet/label to the n-1 sheet/label when the number of copies is set to n. A back-feed operation is then performed at the trailing edge of the last sheet/label or when printing a single sheet/label.

Home menu	Sub menu	Default	Configurable range	Notes
After Print - 2	Paper Position	0.00 inch 0.00 mm	STD 0.00 to 2.00 inch 0.0 to 50.8 mm Cut/Tear -1.00 to 1.00 inch -25.4 to 25.4 mm	Adjusts the stop position. This setting is dependent on the Metric/Inch setting. Each device has an initial stop position as configured with the settings previously described. This setting sets a relative value from these other settings.
	Feed Key Action	FEED Key	Repeat Last Set Repeat Last One FEED Key	Changes the operation of the FEED key Repeat Last Set Reprints a set of labels. This setting is ignored when Zebra® emulation mode is selected. Repeat Last One Reprints the last page only. Prints only 1 sheet/label from the current number when using counts. FEED Key Functions as the FEED key. Disables reprinting.

Home menu	Sub menu	Default	Configurable range	Notes
Interface	RS-232C Baud Rate	9600	115200 57600 38400 19200 9600 4800 2400	Sets the baud rate of the serial interface
	RS-232C Parity	None	None Odd Even	Sets the communication parity of the serial interface
	RS-232C Length	8 bits	8 bits 7 bits	Sets the data length for the serial interface
	RS-232C Stop bit	1 bit	1 bit 2 bits	Sets the stop bits for the serial interface
	RS-232C X-ON	Yes	Yes No	Enables/disables X-ON flow control for the serial interface
	USB Device Class	Printer	Printer VCOM	Sets the USB device class
	USB VCOM Protocol	Auto	Auto DTR X-ON	Sets the USB VCOM protocol (flow control)
	IPv4 Address	169.254.001.010	000.000.000.000 to 255.255.255.255	Sets the IPv4 network address
	IPv4 Subnet Mask	255.255.000.000	000.000.000.000 to 255.255.255.255	Sets the IPv4 subnet mask
	IPv4 Gateway	000.000.000.000	000.000.000.000 to 255.255.255.255	Sets the IPv4 gateway
	IPv4 DHCP	On	On Off	Enables/disables IPv4 DHCP
	IPv6	On	On Off	Enables/disables IPv6

Home menu	Sub menu	Default	Configurable range	Notes
Machine Information	Model Number	-	CL-E300	Displays the model number. *Appears as "CL-E303" for the CL-E303 model.
	Boot Version	-	*.*	Displays the boot version
	ROM Version	-	*****	Displays the ROM version
	ROM Date	-	**/**/**	Displays the ROM creation date
	ROM CheckSum	-	****	Displays the ROM checksum
	Print Counter	-	**** * km	Displays the print counter
	Service Counter	-	**** * km	Displays the service counter
	Cut Counter	-	*****	Displays the cut counter only for models with cutters
	Sensor Monitor	-	*.* V	Displays the sensor level
	MAC Address	-	**.*.*.*.*.*	Displays the MAC address
Global Configuration	-	Config Set 1	Config Set 1 Config Set 2 Config Set 3	Configuration number setting

5.2 Obtaining the LabelPrinterUtility

1. Access the following URL from a PC to download the LabelPrinterUtility.
http://www.citizen-systems.co.jp/support/download/printer/label/index_en.html
2. Save the downloaded LabelPrinterUtility.exe to the desired folder.

5.3 Using the LabelPrinterUtility

- **Start LabelPrinterUtility.exe.**
Refer to the user manual for more information on using the application.

6. Configuring Ethernet Network Settings Using Network Seeker

By using “CITIZEN Network Seeker”, utility software that runs on Windows, you can check and change the Ethernet interface board settings.

6.1 Starting Network Seeker

After obtaining the program “NetSeeker.exe” from the CD-ROM or our website, double click the program. A dialog box appears. Click “Seek” to start a LAN IF search.

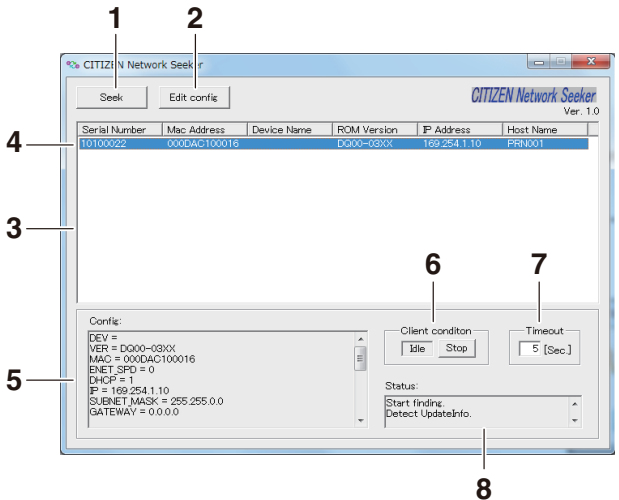

1. “Seek” button
Start a search for Ethernet interface boards on the network.
Waits for a response during the time configured with [Communication timeout].
2. “Edit config” button
Change the settings of the selected board.
3. Board information list
Single click to select a board and double click to change settings.

4. Board information
Single click to select a board and double click to change settings.
5. Configuration display section
View the settings of the selected board.
6. Client condition display
When “Busy” is displayed, operations to search, change settings, and so on are prohibited.
If you click “Stop”, the “Busy” status is cleared forcibly.
7. Communication timeout
You can configure the time-out duration for searches and other operations.
8. Status log
View the status of the utility.

6.2 Changing Settings

You can configure an Ethernet interface board by selecting it at the main dialog box, and then clicking “Edit config”.

1. These are unalterable parameters.
These parameters are for display purposes only.
2. These are changeable parameters.
Users can change these parameters.

7. Configuring Printer Settings Using a Browser

Printer and network settings can be configured using a Web browser via the printer's built-in LinkServer function.

7.1 LinkServer user roles

LinkServer has the following three user roles available: User, Operator, and Administrator. The menus that appear for each user role can be changed to restrict operational access to LinkServer.

The Home screen for the user role appears when first connecting.

7.2 LinkServer menu configuration

The following figure illustrates the LinkServer menu configuration.

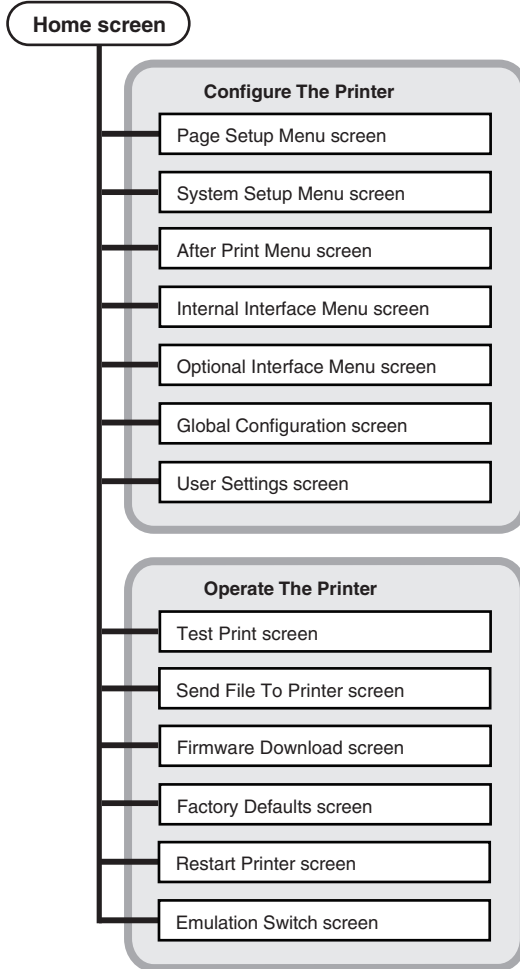

7.3 LinkServer connection procedure

1. Open a Web browser and enter the IP address of the desired printer into the address bar (area circled in red).

The example illustrates the entry of "http://169.254.1.10".



2. Press the [LOG IN] to display the authentication window.



3. Enter your user name and password.

The default authentication credentials for the Operator role are as follows.

- User name: Operator
- Password: Operator

The default authentication credentials for the Administrator role are as follows.

- User name: Admin
- Password: Admin

The user name and password for the Operator and Administrator roles can be changed in the User Settings menu. User names and passwords can contain up to 20 single-byte, alpha-numeric characters and symbols.

After successful authentication, the Home screen for the Operator or Administrator role appears.

Administrator Home Screen



The menus that appear for the User and Operator roles can be changed from the User Settings menu.

4. Press the Menu button on the Home screen to perform printer operations.

- Printer Information: Displays printer information.
- Configure The Printer: Provides access to the same settings as configured with LabelPrinterUtility.
- Operate The Printer: Used to operate the printer.

5. Once you are finished, press the [LOG OUT] button to log out.

The Home screen for the User role appears again after logging out.

8. Configuring the Printer Using the Operation Panel

The following operations can be performed from the control panel after changing the printer operation mode to the special mode.

- Adjust media sensors
- Print test samples
- Print the settings configuration
- Change emulation modes
- HEX dump mode
- Initialize the printer

*This device is not equipped with the [Menu Configuration Mode] featured in other models.

1. With the top cover closed, turn on the power to the printer while pressing and holding the FEED key.

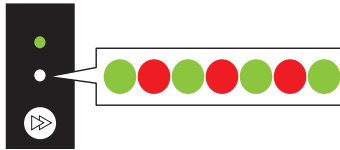

The printer changes to the special mode.

The buzzer emits 3 short tones and the status LED flashes alternately in green and red.



2. Press the FEED key to select the desired operation mode.

Mode	Buzzer	Status LED	
		Color	Interval
Special function mode	3 short tones	Alternately in green and red	Flashes quickly
Press the FEED key ↓			
Sensor Adjustment Mode	1 short tones	Green	Flashes
Press the FEED key ↓			
Test print mode	2 short tones	Green	Flashes quickly
Press the FEED key ↓			
Configuration print mode	3 short tones	Amber	Flashes
Press the FEED key ↓			

Mode	Buzzer	Status LED	
		Color	Interval
Emulation switching mode	4 short tones	Amber	Flashes quickly
			
Press the FEED key ↓			
HEX dump mode	5 short tones	Red	Flashes
			
Press the FEED key ↓			
Initialization mode	6 short tones	Red	Flashes quickly
			
Press the FEED key ↓			
Returns to the sensor adjustment mode.			

3. **Once the desired operation mode has been selected, press and hold the FEED key for at least 3 seconds.**
4. **Release the FEED key once the buzzer emits a long tone.**
The printer is now in the desired operation mode.
5. **After finishing use of operation modes, press and hold the FEED for at least 3 seconds to return to the normal startup mode.**
After you have finished configuring each mode, restart the printer.
 - **To return to the normal startup mode without selecting an operation mode after changing to the special function mode, press and hold the FEED key for at least 3 seconds.**
 - **If you continue to press and hold the FEED key for at least 3 seconds after the buzzer emits a long tone, the buzzer will emit 4 short tones, and then printer restarts.**
 - **The printer restarts, and changes to normal mode.**

8.1 Sensor Adjustment Mode

Use this mode to adjust media sensors (upper or lower) in accordance with the media used.

Set the sensor position and media before starting this adjustment procedure.

Setting transmissive sensor positions and media

1. Align the bottom sensor and upper sensor with each other at the same position.



Refer to Transmissive Sensor Adjustment

2. Peel a label and set the media so that only the backing paper (glassine paper) reaches the platen roller and media sensor.

If the media has black lines, do not set the media so that a black line is between the sensors.

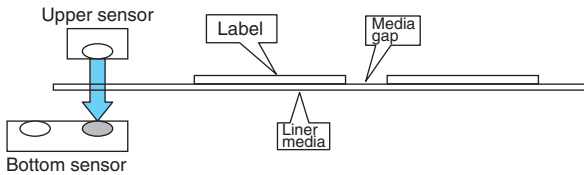

3. Adjust the sensors.



Refer to Sensor adjustment

Setting reflective sensor positions and media

1. Adjust the reflective sensor so that it is underneath the media.
2. Set the media so that the media covers the platen roller and media sensor.
 - Using continuous media and label media without gaps between labels
Set the media so that a section without a black line (or label face stock for label media) does not cover the platen roller and media sensor.

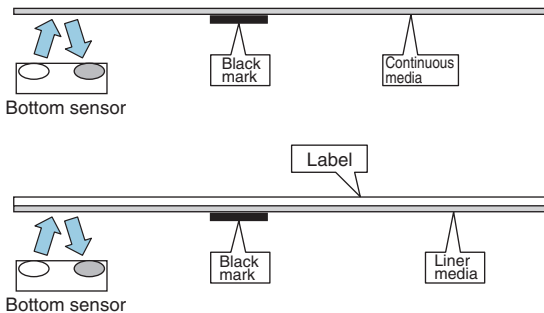

- Using label media with gaps
Peel a label and set the media so that only the backing paper (glassine paper) reaches the platen roller and media sensor.

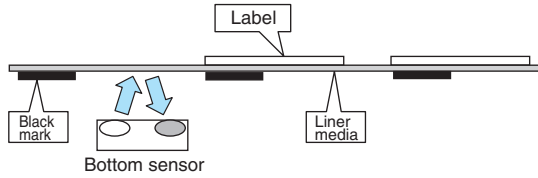

3. Adjust the sensors.



Refer to Sensor adjustment

Sensor adjustment

- Turn on the power to the printer while pressing and holding the FEED key to start the printer in special function mode.
- Press the FEED key once to select sensor adjustment mode.
The buzzer emits 1 short tone.
The status LED also flashes in green.

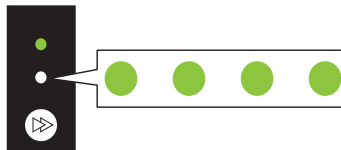

- Press and hold the FEED key for at least 3 seconds.
- Release the FEED key once the buzzer emits a long tone and then press the FEED key again.
The printer is now in sensor adjustment mode.
- Press the FEED key to select either transmissive sensor or reflective sensor.
Each press of the FEED key toggles between transmissive sensor and reflective sensor options.

Sensor	Buzzer	Status LED	
		Color	Interval
Transmissive sensor	1 short tones	Green	Flashes
Press the FEED key ↓			
Reflective sensor	2 short tones	Green	Flashes quickly

- Press and hold the FEED key for at least 3 seconds.

7. Release the FEED key once the buzzer emits a long tone.

The sensor adjustment process starts.

- Once sensors have been adjusted, the buzzer emits 1 short tone, and the printer restarts.
- The buzzer emits 1 long tone if sensor adjustment fails. If this happens, check the sensor and media positions.

● To cancel sensor adjustment, continue pressing and holding the FEED key for at least 3 seconds at step 7.

The buzzer emits 4 short tones, and the printer restarts.

8.2 Test print mode

This mode prints the test sample.

This printer can print test samples to label media and continuous media.

Printing test samples is a quick way to check print quality.

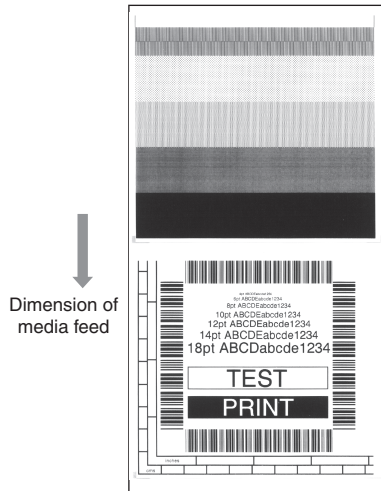

Load media and then perform the following procedure.

1. Turn on the power to the printer while pressing and holding the FEED key to start the printer in special function mode.
2. Press the FEED key twice to select test print mode.

The buzzer emits 2 short tone.

The status LED also flashes quickly in green.

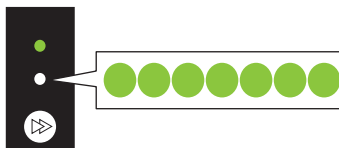



3. **Press and hold the FEED key for at least 3 seconds.**
4. **Release the FEED key once the buzzer emits a long tone.**

The printer is now in test print mode.

5. **Press the FEED key to select the media.**

Each press of the FEED key toggles between label media and continuous media.

Media	Buzzer	Status LED	
		Color	Interval
Label media	1 short tones	Green	Flashes
			
Press the FEED key ↓			
Continuous	2 short tones	Green	Flashes quickly
			

6. **Press and hold the FEED key for at least 3 seconds.**
7. **Release the FEED key once the buzzer emits a long tone.**

The test print process starts.

 - Once the test sample has been printed, press the FEED key to print another test sample without a feed operation.
8. **Once the test sample has been printed, turn the power to the printer off and on again to reset the printer in the normal startup mode.**
- **To cancel test printing, continue pressing and holding the FEED key for at least 3 seconds without releasing your finger at step 7.**

The buzzer emits 4 short tones, and the printer restarts.



CAUTION

Normal mode printing can also be performed when the printer is in test print mode. Note that pressing the FEED key while the printer is in test print mode will not feed media. Instead, it will print a test sample.

8.3 Configuration Print Mode

This mode is used to print the printer settings configuration when using continuous media mode. Printing the current settings configuration is a quick way to check the current configuration.

Example of printed settings configuration

Machine Information	
Model Number	: CL-E300
Boot Version	: 0.0
ROM Version	: *****
ROM Date(DD//MM//YY)	: **/**/**
ROMCheck Sum	: ****
Print Counter	: 0001.234km
Service Counter	: 0001.234km
Cut Counter	: 0
Sensor Monitor	: 1.50V
MAC Address	: ff:ff:ff:ff:ff:ff

Current Menu Setting	
[Global Config Menu]	
Config Set	: 1
[PageSetup Menu]	
Print Speed	: 6 IPS
Print Darkness	: 10
Darkness	: 00
Feed Key Action	: Feed Key
[Interface Menu]	
RS-232C Baud rate	: 9600 bps
RS-232C Parity	: None
RS-232C Length	: 8 bit
RS-232C Stop bit	: 1 bit
RS-232C X-ON	: Yes
USB Device Class	: Printer
USB VCOM Protocol	: Auto
IPv4 Address	: 000.000.000.000
IPv4 Subnet Mask	: 000.000.000.000
IPv4 Gateway	: 000.000.000.000
IPv4 DHCP	: On
IPv6	: On

Load media and then perform the following procedure.

1. Turn on the power to the printer while pressing and holding the FEED key to start the printer in special function mode.
2. Press the FEED key 3 times to select configuration print mode.

The buzzer emits 3 short tone.

The status LED also flashes in amber.

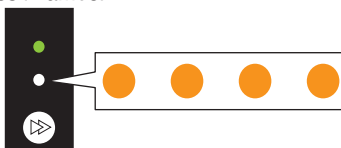

3. Press and hold the FEED key for at least 3 seconds.
4. Release the FEED key once the buzzer emits a long tone.

The printer is now in settings print mode.

5. **Press and hold the FEED key for at least 3 seconds.**
6. **Release the FEED key once the buzzer emits a long tone.**
The configuration print process starts.
Once the configuration has been printed, the printer will be in the online state.
7. **To print configurations that include default settings, continue pressing and holding the FEED for at least 3 seconds without releasing your finger at step 6.**
8. **Release the FEED key once the buzzer emits a long tone and then press the FEED key again.**
The process to print a configuration that includes default settings starts.
Once the configuration has been printed, the printer will be in the online state.
- **To cancel configuration printing, continue pressing and holding the FEED key for at least 3 seconds without releasing your finger at step 7.**
The buzzer emits 4 short tones, and the printer restarts.

8.4 Emulation switching mode

This mode is used to change the command set used.
The default setting is [DMX mode].

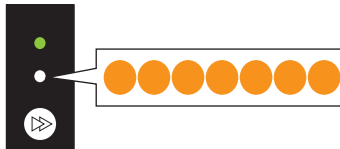

1. **Turn on the power to the printer while pressing and holding the FEED key to start the printer in special function mode.**
2. **Press the FEED key 4 times to select emulation switching mode.**
The buzzer emits 4 short tone.
The status LED also flashes quickly in amber.



3. **Press and hold the FEED key for at least 3 seconds.**
4. **Release the FEED key once the buzzer emits a long tone.**
The printer is now in emulation switching mode.

5. Press the FEED key to select an emulation switching mode.

Each press of the FEED key cycles through the emulation mode options including DMX mode and ZPL mode.

Emulation mode	Buzzer	Status LED	
		Color	Interval
DMX mode	1 short tones	Green	Flashes
			
Press the FEED key ↓			
ZPL mode	2 short tones	Green	Flashes quickly
			
Press the FEED key ↓			
Returns to DMX mode.			

6. Press and hold the FEED key for at least 3 seconds.

7. Release the FEED key once the buzzer emits a long tone and then press the FEED key again.

The selected emulation mode is set, and the printer restarts.

- **To cancel setting the emulation mode, continue pressing and holding the FEED key for at least 3 seconds without releasing your finger at step 7.**

The buzzer emits 4 short tones, and the printer restarts.

8.5 HEX Dump Mode

This mode is used to print a hex dump list (data received by the printer represented in hex values) for confirmation of the data content.

Example of dump list printing

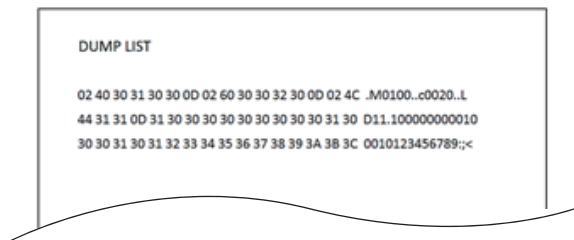

Load media and then perform the following procedure.

- 1. Turn on the power to the printer while pressing and holding the FEED key to start the printer in special function mode.**

2. Press the FEED key 5 times to select HEX dump mode.

The buzzer emits 5 short tone.
The status LED also flashes in red.

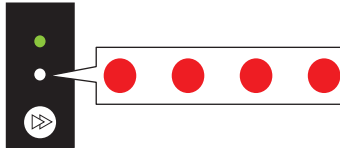

- 3. Press and hold the FEED key for at least 3 seconds.**
- 4. Release the FEED key once the buzzer emits a long tone.**
The printer is now in HEX dump mode.
- 5. Press the FEED key to select the media.**

Each press of the FEED key toggles between label media and continuous media.

Media	Buzzer	Status LED	
		Color	Interval
Label media	1 short tones	Green	Flashes
Press the FEED key ↓			
Continuous	2 short tones	Green	Flashes quickly

- 6. Press and hold the FEED key for at least 3 seconds.**
- 7. Release the FEED key once the buzzer emits a long tone and then press the FEED key again.**
The hex dump list print process starts.
- 8. Once the HEX dump list has been printed, turn the power to the printer off and on again to reset the printer in the normal startup mode.**
- **To cancel HEX dump mode, continue pressing and holding the FEED key for at least 3 seconds without releasing your finger at step 7.**
The buzzer emits 4 short tones, and the printer restarts.

8.6 Initialization Mode

This mode is used to initialize printer settings and the user memory area.

- 1. Turn on the power to the printer while pressing and holding the FEED key to start the printer in special function mode.**

2. Press the FEED key 6 times to select initialization mode.

The buzzer emits 6 short tone.
The status LED also flashes quickly in red.

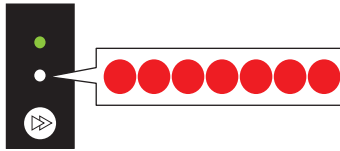

3. Press and hold the FEED key for at least 3 seconds.

4. Release the FEED key once the buzzer emits a long tone.

The printer is now in initialization mode.

5. Press the FEED key to select initialization of settings or initialization of the user memory area.

Each press of the FEED key toggles between settings initialization and user memory area initialization.

Initialization option	Buzzer	Status LED	
		Color	Interval
Settings initialization	1 short tones	Green	Flashes
Press the FEED key ↓			
User memory area initialization	2 short tones	Green	Flashes quickly

6. Press and hold the FEED key for at least 3 seconds.

7. Release the FEED key once the buzzer emits a long tone and then press the FEED key again.

Once the selected initialization process completes, the printer restarts.

● To cancel setting the initialization mode, continue pressing and holding the FEED key for at least 3 seconds without releasing your finger at step 7.

The buzzer emits 4 short tones, and the printer restarts.

9. Online Configuration Mode

1. **Press and hold the FEED key for at least 3 seconds while the printer is online and not receiving data.**

The printer is now in online configuration mode.

The buzzer emits 3 short tones and the status LED flashes alternately in green and red.

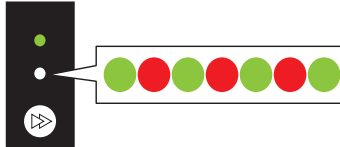

2. **Press the FEED key to select media sensor mode.**

Media sensor mode	Buzzer	Status LED	
		Color	Interval
Transmissive sensor mode	1 short tones	Green	Flashes
Press the FEED key ↓			
Reflective sensor mode	2 short tones	Green	Flashes quickly
Press the FEED key ↓			
Continuous media mode	3 short tones	Amber	Flashes
Press the FEED key ↓			
Returns to the transmissive sensor mode.			

3. **Press and hold the FEED key for at least 3 seconds.**
 4. **Release the FEED key once the buzzer emits a long tone.**
The selected media sensor mode is set.
- **To cancel online configuration mode, continue pressing and holding the FEED key for at least 3 seconds without releasing your finger at step 4.**
The buzzer emits 4 short tones, and the printer restarts.

10. Clearing Jobs Stored in the Printer

Jobs stored in the printer can be cleared when the printer is paused.

- 1. Press the FEED key if the printer is printing or receiving data.**
The printer is now paused.
- 2. Press and hold the FEED key for at least 3 seconds.**
The buzzer emits 1 short tone.
- 3. Release the FEED key.**
One job has been cleared.
Alternatively, continue to press and hold the FEED key for at least 3 second without releasing your finger until the buzzer emits 2 short tones.
- 4. Release the FEED key once the buzzer emits 2 short tones.**
All jobs have been cleared.

11. Maintenance

Perform printer maintenance on a regular basis to ensure that the printer is always in good working condition.

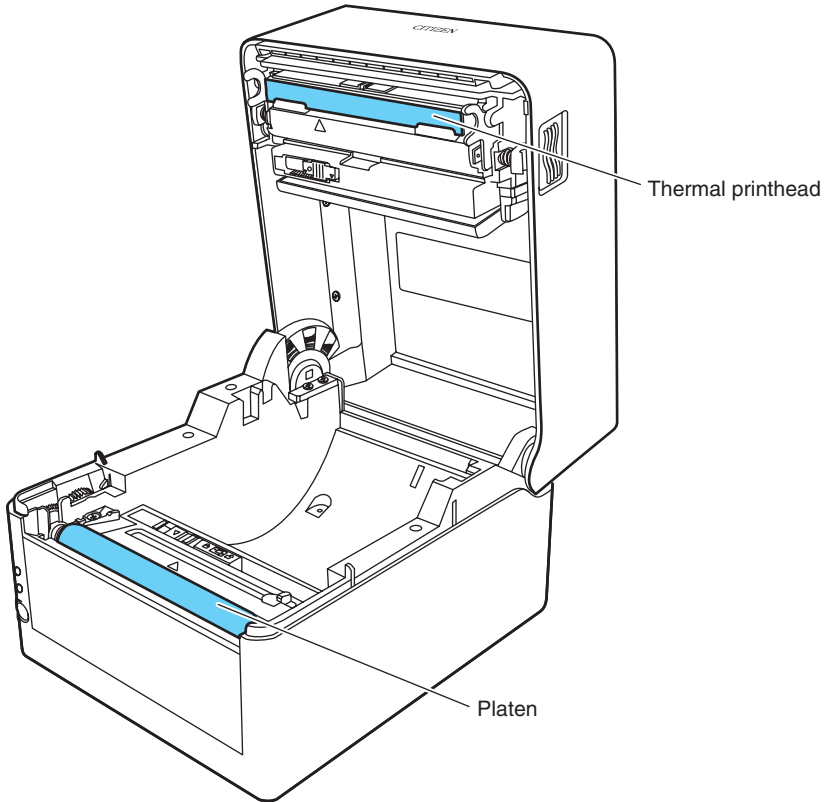

CAUTION

Excluding ethyl alcohol, do not use solvents such as benzene, acetone, thinner, or others to clean the printer. Doing so may cause the printer surface or other parts to deform.

11.1 Plastic Surface of Printer and Platen

- Use a soft cloth or cotton swab dipped with a small amount of ethyl alcohol to wipe off dust and dirt.



CAUTION

Using an excessive amount of ethyl alcohol to clean the platen may cause surface deformation, which would result in unstable feed operation.

11.2 Thermal head

- Use a cotton swab dipped with a small amount of ethyl alcohol.



CAUTION

- The thermal head is hot immediately after printing. Do not touch the thermal head at this time.
- Do not touch the thermal head with bare hands or do not allow metals to come into contact with the thermal head.

12. Appendices

12.1 Troubleshooting

The status LED and buzzer are used to confirm error status when errors occur in the printer.

Status LED	Buzzer	Error	Error description (in bold) and resolution
Flashes in red	2 short tones	Head Up Error	Top cover is not closed correctly. <ul style="list-style-type: none">• Close the top cover correctly.
Flashes in red	3 short tones	End of Media Error	Printer has run out of media. Media is not set correctly. <ul style="list-style-type: none">• Open the top cover and load media or set the media correctly.
Flashes in red	4 short tones	Media Load Error Media Jam Error	Label gaps or black lines cannot be detected. <ul style="list-style-type: none">• Check the media sensor positions.• Readjust the media sensors.• Make sure the selection of transmissive sensor, reflective sensor, or continuous media matches the type of media used. Media cannot be transported. <ul style="list-style-type: none">• Open the top cover, remove any media blocking transport, and set the media again.
Flashes in red	6 short tones	Cutter Error (models with cutters)	Cutter is not operating. <ul style="list-style-type: none">• Open the top cover and remove any media or other object blocking cutter operation.• If the cutter does not operate after removing foreign objects, the cutter may not be connected or installed correctly or may have failed. Contact your retailer. Home position cannot be detected. <ul style="list-style-type: none">• The auto cutter may have failed. Contact your retailer.
Flashes in amber	Repetitions of long tones	Head Low Temperature Error	The thermal head is at a low temperature (approximately -10°C). <ul style="list-style-type: none">• Use the printer in proper environments of at least 0°C. The thermal head is not connected. <ul style="list-style-type: none">• Check the cable connection with the thermal head.

Status LED	Buzzer	Error	Error description (in bold) and resolution
Flashes in amber	None	Head High Temperature Alarm Motor High Temperature Alarm	The thermal head or feed motor is at a high temperature. <ul style="list-style-type: none"> • Printing stops if the thermal head reaches approximately 70°C or more while printing. Printing resumes automatically once the temperature falls to approximately 60°C or lower. • Printing stops if the feed motor reaches approximately 95°C or more while operating. Printing resumes automatically once the temperature falls to approximately 85°C or lower.
Flashes alternately in red and green	Repetitions of long tones	RS-232C Communication Error	Parity error Framing error Receive buffer is full Transmission buffer is full <ul style="list-style-type: none"> • Check the communication settings.
Flashes alternately in red and amber	Repetitions of long tones	Hardware Error	A hardware error has been detected. <ul style="list-style-type: none"> • Immediately turn off the power to the printer and contact your retailer.

12.2 Basic Specifications

Printing

Item	Description	
Print method	Direct thermal	
Resolution	CL-E300	Main scanning line density: 203 dots/inch (8 dots/mm)
		Sub-scanning line density: 203 dots/inch (8 dots/mm)
		Head dots: 864 dots (effective dots: 832)
	CL-E303	Main scanning line density: 300 dots/inch (11.8 dots/mm)
		Sub-scanning line density: 300 dots/inch (11.8 dots/mm)
		Head dots: 1248 dots (effective dots: 1240)
Max. print width	CL-E300	104 mm / 4.1 inch
	CL-E303	105 mm / 4.1 inch
Max. print length	CL-E300	(Datamax) 2539.7 mm/99.99 inch
		(Zebra) 2540.0 mm/100.00 inch
	CL-E303	1,270.0 mm / 50.00 inch
Print density	Print density is adjustable with software	

Print speed

Item	Description	
Print speed setting	CL-E300	2 to 8 inch per second in 1-inch increments (7 to 8 inch per second possible at normal temperature using a print density of 10 and the recommended direct thermal media)
	CL-E303	2 to 6 inch per second in 1-inch increments

Print mode

Item	Description
Batch mode	Normal printing (single or multiple sheets)
Tear off mode	Back-feeds to the tear-off position after printing is complete. (Labels may peel when roll media is back-fed.)
Cut mode	Prints while cutting after every specified number of sheets/labels. Two types of cut mode operations are available. <ul style="list-style-type: none"> • Back-feed • Cut-through (Cut-through pauses printing to cut the previous label when it reaches the cut position. Printing resumes after the cut operation, but a gap may be formed at the location where printing was paused.)

Media

Item	Description	
Media types	Roll, fanfold media (Continuous label media, die-cut media, continuous tag media, and continuous ticket media)	
Roll media orientation	Outer surface	
Recommended media	Label media (Ricoh 150LA-1), tag media (Ricoh 130LHB)	
Max. media width	118.0 mm / 4.65 inch	
Min. media width	25.4 mm / 1.00 inch	
Min. label width	21.5 mm / 0.85 inch	
Min. media pitch*1	6.35 mm / 0.25 inch*2	
Max. media thickness	Standard type	0.19 mm / 0.0075 inch
	Integrated cutter type	
	Separable cutter type	0.15 mm / 0.0059 inch
Max. media length	CL-E300	(Datamax) 2539.7 mm/99.99 inch (Zebra) 2540.0 mm/100.00 inch
	CL-E303	1,270.0 mm / 50.00 inch
Min. media length*1	6.35 mm / 0.25 inch*2	
Min. media thickness	0.0635 mm / 0.0025 inch	
Loaded roll diameter	Max. external diameter: 127 mm / 5 inch	
	Media core: 25.4 or 38.1 mm / 1 or 1.5 inch	

*1 To use media with a pitch of less than 1 inch, enable the [Small Label Printing] setting.

*2 For models with a cutter, the cutter operation will not be performed if the media length is less than 25.4 mm (1 inch).

Barcodes

Item	Description	
Datamax® emulation	One-dimensional	·Code 3 of 9 ·UPC-A ·UPC-E ·EAN-13 (JAN-13) ·EAN-8 (JAN-8) ·Interleaved 2 of 5 ·Code 128 ·HIBC (Code 3 of 9 using Modulus 43) ·Codabar (NW-7) ·Int 2 of 5 (Interleaved 2 of 5 using Modulus 10) ·Plessey ·Case Code ·UPC2DIG Add ·UPC5DIG Add Code 93 ·Telepen ·ZIP ·UCC/EAN128 ·UCC/EAN128 (for K-MART) ·UCC/EAN128 Random Weight ·FIM
	Two-dimensional	·UPS Maxi Code ·PDF-417 ·Data Matrix ·QR Code ·Aztec ·GS1 DataBar
Zebra® emulation	One-dimensional	·Code 11 ·Interleaved 2 of 5 ·Code 39 ·EAN-8 ·UPC-E ·Code93 ·Code128 ·EAN-13 ·Industrial 2 of 5 ·Standard 2 of 5 ·ANSI CODABAR ·LOGMARS ·MSI ·Plessey ·UPC/EAN Extensions ·UPC-A ·POSTNET ·Planet
	Two-dimensional	·Code49 ·PDF-417 ·CODA BLOCK ·UPS Maxi Code ·Micro PDF-417 ·Data Matrix ·QR Code ·GS1 DataBar ·TLC39 ·Aztec

Fonts

Item	Description
Datamax® emulation	1. 7 types of fixed-pitch fonts 2. OCR fonts OCR-A*3 and OCR-B*3 3. Proportional fonts CG Triumvirate smooth font CG Triumvirate bold smooth font CL-E300: 6, 8, 10, 12, 14, 18, 24, 30, 36, and 48 points CL-E303: 4, 5, 6, 8, 10, 12, 14, 18, 24, 30, 36, and 48 points Character sets: Compliant with code page 850 4. TrueType™ rasterizer
Zebra® emulation	1. 5 types of fixed-pitch fonts 2. OCR fonts OCR-A*3 and OCR-B*3 3. Proportional fonts CG Triumvirate Condensed Bold 4. TrueType™ rasterizer

*3 Depending on the reader, OCR font recognition may be poor.

Symbol Sets

Item	Description
Single-byte sets	·PC866U Ukrainian*4 ·PC Cyrillic ·ISO 60 Danish/Norwegian ·Desk Top ·ISO 8859/1 Latin 1 ·ISO 8859/2 Latin 2 ·ISO 8859/9 Latin 5 ·ISO 8859/10 Latin 6 ·ISO 8859/7 Latin/Greek ·ISO 8859/15 Latin 9 ·ISO 8859/5 Latin/Cyrillic ·ISO 69: French ·ISO 21: German ·ISO 15: Italian ·Legal, Math-8 ·Macintosh ·Math ·PC-858 Multilingual ·Microsoft Publishing ·PC-8 ·Code Page 437 ·PC-8 D/N ·Code Page 437N ·PC-852 Latin/Greek ·PC-862 Latin/Hebrew ·Pi Font ·PC-850 Multilingual ·PC-864 ·Latin/Arabic ·PC-8 TK ·Code Page 437T ·PC-1004 ·PC-775 Baltic ·Non-UGL ·Generic Pi Font ·Roman-8 ·Roman-9 ·ISO 17: Spanish ·ISO 11: Swedish ·Symbol ·PS Text ·ISO 4: United Kingdom ·ISO 6: ASCII ·Ventura International ·Ventura Math ·Ventura US ·Windows 3.1 Latin 1 ·Wingdings ·Windows 3.1 Latin 2 ·Windows 3.1 Baltic (Latv, Lith) ·Windows 3.0 Latin 1 ·Windows Latin/Cyrillic ·Windows 3.1 Latin 5
Double-byte sets	·EUC ·JIS ·Shift JIS ·Unicode ·KS Code ·GB Code

*4 “PC866U Ukraina” is supported only in Datamax® emulation.

Control Languages

Supports the Datamax® language and Zebra® language

Digital Processing Components

Item	Description
CPU	32-bit RISC CPU (max. operation frequency of 216 MHz)
ROM	16 MBytes of flash ROM (user area: 4 MBytes)
RAM	32 MBytes of SDRAM (user area: 4 MBytes)

Media detection sensors

Item	Description
Transmissive sensor	Detects label gaps, tag notches, and out of media state
Reflective sensor	Detects black lines on back of media and out of media state

Communication interfaces

Item	Description
USB	Full-speed USB 2.0 (12 Mbps), Type B connector
Ethernet	100BASE-TX / 10BASE-T, RJ45 connector
Serial	RS232C, 9-pin D-SUB female connector Baud rates: 2400, 4800, 9600, 19200, 38400, 57600, and 115200 bps

Indicators and switches

Item	Description
LED	Power on (green), status/errors/alarms (green, red, and amber)
Buzzer	Alarms, warnings, and other indications
Operation keys	1 (Performs feed and other operations)
Head-up detection switch	Detects head-up states
Ethernet panel button	Prints and initializes Ethernet settings
Power switch	Turning the Power On/Off

Power supply

AC adapter (CEC Level VI-compliant)

Input: 100 to 240 VAC, 50/60 Hz

Output: 24 VDC, 2.5 A

Supported Standards

- UL: 60950-1st, 2nd Edition
- CSA: No. 950
- FCC: 47 CFR Part 15, Subpart B, Class B
- EN: 60950-1
- EN: 55032:2012 Class B
- EN: 55024:2010
- EN: 61000-3-2:2014
- EN: 61000-3-3:2013
- EU: RoHS (2011/95/EC)
- Energy Star: Energy Equipment, Version2.0
- CCC: GB4943.1-2011, GB9254-1998, and GB17625.1-2003
- KC-Mark / BIS / NOM-Mark / S-mark SIN (AC Adapter) / RCM

Environmental conditions

Item	Description
Operating temperature	Safe operating temperature: 0 to 40°C Safe printing temperature: 5 to 35°C Humidity: 30 to 80%, no condensation (conditions: well-ventilated environment and natural convection)
Storage temperature conditions	Temperature: -20 to 60°C, Humidity: 5 to 85% (conditions: stored with head up, record sheet is excluded, no condensation, well-ventilated area, natural convection) *However, combined temperature and humidity conditions for storage in hot and humid environments should be a maximum of 40°C and 85% RH (no condensation).

Electrostatic Voltage

EN61000-4-2:2009-compliant

AC Power Consumption

Item	Description
CL-E300	100 V/50 Hz: 1.5 W standby, 71 W during operation (USB, print speed of 8 IPS, print density of 10, printing rate of 12.5 %) 220 V/50 Hz: 1.5 W standby, 65 W during operation (USB, print speed of 8 IPS, print density of 10, printing rate of 12.5 %)
CL-E303	100 V/50 Hz: 1.5 W standby, 57 W during operation (USB, print speed of 6 IPS, print density of 10, printing rate of 12.5 %) 220 V/50 Hz: 1.5 W standby, 55 W during operation (USB, print speed of 6 IPS, print density of 10, printing rate of 12.5 %)

External Dimensions



Refer to External Dimensions

Weight

- CL-E300X***NX (standard type): 2.0 kg
 - CL-E300X***BC (integrated cutter type): 2.3 kg
 - CL-E300X***PC (separable cutter type): 2.2 kg
- *Excludes media, the AC adapter, and power cord.

Accessories

- Quick Start Guide/Safety Instructions
- CD-ROM
- AC adapter
- Power cord
- Media holder and media shaft
- USB cable

Factor Options (the default setting)

- Cutter unit (integrated or separable)

External Dimensions *5

CL-E300X***NX (standard type)

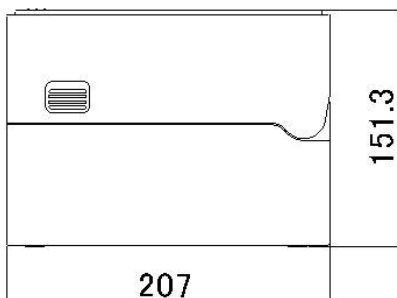
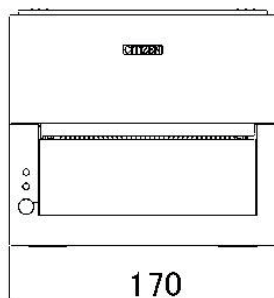
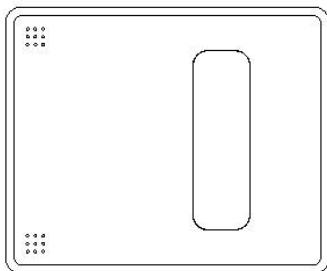

CL-E300X***NS (with AC adapter case)

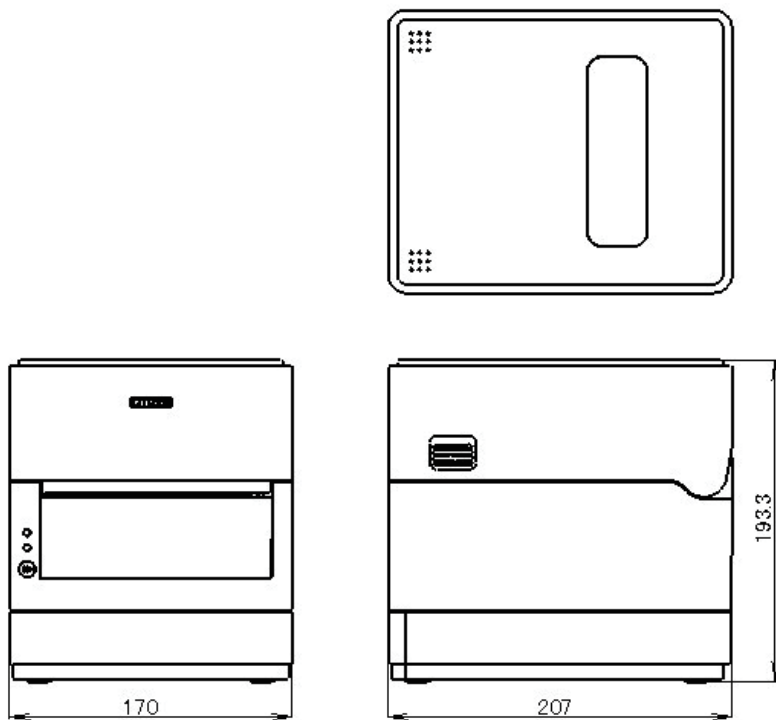

CL-E300X***BC (with integrated cutter)

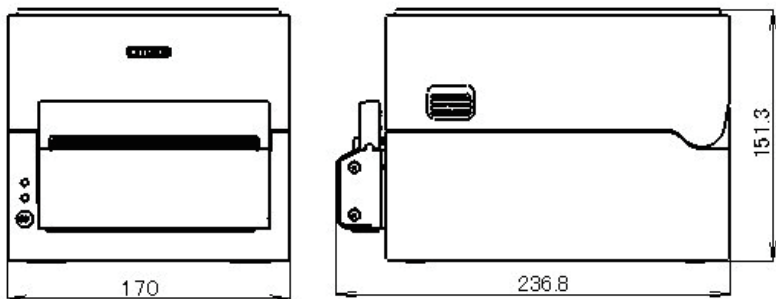

CL-E300X***PC (with separable cutter)

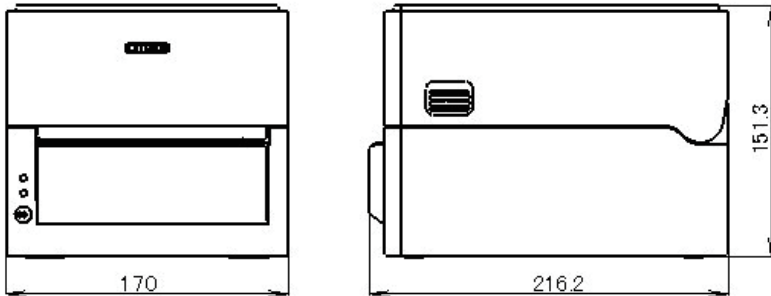

*5 Dimensions are design values. Actual dimensions may vary due to variance in manufacturing processes.

12.3 Usage Conditions

- (1) Safe operating temperature: 0 to 40°C
- (2) Safe printing temperature: 5 to 35°C
- (3) Humidity: 30 to 80% RH (no condensation)

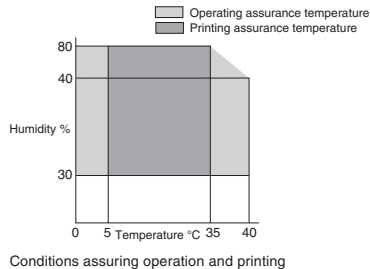

12.4 Printer Storage Conditions

- (1) Temperature: -20 to 60°C (excluding record sheet)
- (2) Humidity: 5 to 85% RH (excluding record sheet, no condensation)

*However, for storage at high temperature and humid environments, the combination of 40°C and 85% RH (no condensation) is taken as the worst value.

12.5 Interfaces

USB Interface

Specifications

Standard	Compliant with Universal Serial Bus Specification 2.0
Transmission speed	Supports Full-speed 12 Mbps transfer
Receive buffer	16 kB receive buffer
Connector	USB Type B connector

Signal Line/Pin Assignment

Signal code	Signal	Pin No.	Function
VBUS	USB power	1	USB power (+5 V)
D-	Negative signal line	2	Negative signal line
D+	Positive signal line	3	Positive signal line
GND	GND	4	GND

Ethernet Interface

Supported Protocols

Supported Protocols	ARP, IP, and TCP
Transport layer protocols	TCP and UDP
Application layer protocols	DHCP, HTTP, SNMP, and Raw Socket Port

Raw Socket Port

Performs bidirectional communication of print data and printer status.

Port No.	9100 (user-configurable)
Direction of port communication	Bidirectional
Max. socket connections	8
Printable connections	1 (other sockets are reserved)
Timeout	Default: 60 seconds Configurable between 0 and 300 seconds. Value of 0 disables timeouts.

HTTP Server

The Web monitoring function can be used to configure printer and network settings. Refer to the pages describing the Web monitor for more information.



Refer to 7. Configuring Printer Settings Using a Browser

Port No.	80
Max. simultaneous connections	4
HTTP version	HTTP/1.1

DHCP

Automatically retrieves IP address information from a DHCP server within 60 seconds after the power is turned on.

If IP address information cannot be retrieved automatically, a fixed IP address (default is 169.254.1.10) is applied.

SNMP Agent

SNMP Version	SNMPv2 (Trap function not supported)
Port No.	161
Supported MIBs	HOST-RESOURCES-MIB and Citizen-MIB (Private)
Community name	public

Connector Connections

Pin No.	Signal	Function
1	TX+	Transmit (positive)
2	TX-	Transmit (negative)
3	RX+	Receive (positive)
4	N.C.	-
5	N.C.	-
6	RX-	Receive (negative)
7	N.C.	-
8	N.C.	-

Compatible connectors

Printer: RJ-45 connector

LED operation

The following table describes port LED operation.

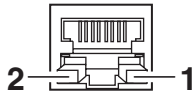

1. Network communication speed indicator

Communication speed	LED (Green)
100 Mbps	On
10 Mbps/disconnected	Flashes

2. Network status indicator

Status	LED (amber)
Connecting	On
Disconnected	Off
Exchanging data	Flashes

Serial Interface

Interface Specifications

Transfer method	Start-stop synchronization method, full-duplex communication
Signal level	RS-232C
Baud rates	2400, 4800, 9600, 19200, 38400, 57600, and 115200 bps
Data length	7 bits or 8 bits
Stop bits	1 bits or 2 bits
Parity	Even, odd, or none
Interface	9-pin D-SUB female connector

Signal Line/Pin Assignment

Signal code	Signal	Pin No.	Function
INIT	Reset	1	Reset printer signal line
RXD	Receive data	2	Signal line used by printer to receive data from external devices
TXD	Transmit data	3	Signal line used by printer to send data to external devices
DTR	Data terminal ready	4	Signal line used by printer to notify external devices that printer is ready to communicate
SGND	Signal line ground	5	Signal line ground reference
DSR	Data set ready	6	Signal line used by external devices to notify printer that they are ready to communicate
RTS	Request to send	7	Signal line used by printer to notify external devices that the printer is ready to receive data
CTS	Clear to send	8	Signal line used by external devices to notify printer that they are ready to receive data
VCC	+5 V	9	(Factory use only)

XON / XOFF Protocol

a Conditions for XON code output

- Communication is possible after the power is turned on.
- Scenario in which the receive buffer has less than 128 bytes available causing output of the XOFF code followed by the receive buffer then having at least 1,024 bytes available.

b Conditions for XOFF code output

- Scenario in which the receive buffer has less than 128 bytes available.

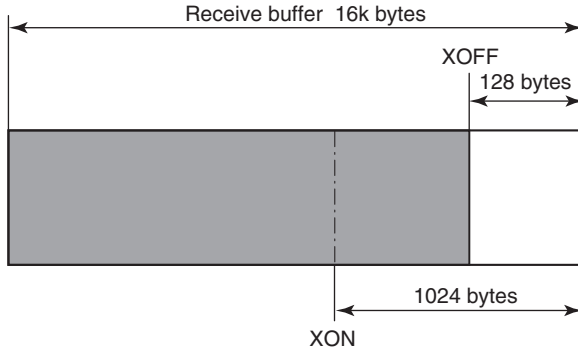

DTR Protocol

a Conditions when DTR signal state changes to Ready (High)

Scenario in which the receive buffer has at least 128 bytes available.

Note that once the receive buffer has less than 1,024 bytes available causing the DTR signal to change to the Busy (Low) state, the DTR signal state remains in the Busy (Low) state until the receive buffer has at least 1,024 bytes available.

b Conditions when DTR signal state changes to Busy (Low)

Scenario in which the receive buffer has less than 128 bytes available.

CITIZEN SYSTEMS AMERICA CORPORATION

363 Van Ness Way, Suite 404 Torrance, CA 90501. USA

Tel: (310) 781-1460 Fax:(310) 781-9152

<http://www.citizen-systems.com>

CITIZEN SYSTEMS EUROPE GmbH

Otto-Hirsch-Brücken 17

70329 Stuttgart

Germany

Tel: +49 (0) 711 49032-0

Fax: +49 (0) 711 49032-45

<http://www.citizen-europe.com>

Elizabeth House, 56-60 London Road

Staines-Upon-Thames, TW18 4HF

United Kingdom

Tel: +44 (0) 20 8893 1900

Fax: +44 (0) 20 8893 0080

CITIZEN SYSTEMS JAPAN CO., LTD.

6-1-12, Tanashi-cho, Nishi-Tokyo-shi Tokyo, 188-8511. Japan

Tel: +81 (0) 42 468 4608 Fax:+81 (0) 42 468 4687

<http://www.citizen-systems.co.jp>

CL-E30X_UM_100EN

PMC-1710

October 2017