



Make It Yours.

COSMOS C700M

User manual / English

التثبيت دليل / Arabic

Инструкция за експлоатация / Български

安装说明 / 简体中文

安裝說明 / 繁體中文

Uživatelská příručka / Čeština

Handuch / Deutsch

Εγχειρίδιο χρήσης / Ελληνικά

Manual de Usuario / Español

Manuel de l'utilisateur / Français

فارسی / راهنمای کاربری

Felhasználói kézikönyv / Magyar

Manuale d'uso / Italiano

ユーザーズマニュアル / 日本語

Handleiding / Nederlands

설치 안내 / korean

Instrukcja Użytkownika / Polski

Manual do Usuário / Português

Руководство пользователя / русский

Uputstvo za korišćenje / Srpski

Kullanım Kılavuzu / Türkçe

Panduan Pengguna / Indonesia

CONTENTS

Package Content	2
Front I/O & Buttons	3
Compatibility	3
Installation Guide	
1 How to remove side panels	4
2 How to install power supply	4
3 How to install motherboard	6
4 How to remove/install GFX bracket & SSD bracket	7
5 How to install add-on cards	8
6 How to install 5.25" devices	10
7 How to install 3.5" devices	13
8 How to install 2.5" devices	15
9 How to install case fans and radiators	17
10 How to install 420mm radiator	18
11 How to install radiator in the rear	21
12 Cable Management	21
13 Completing installation	22
Fan & A-RGB controller operation	23
Control Board Layout	24
I/O connectors	24
Inverse layout adjustment	25
Chimney effect layout adjustment	30

Net Weight		23.4kg / 51.6lb
Available Color		Grey, Silver & Black
Materials		Outlook: Aluminum, Plastic, Steel Body: Steel Side panel: Tempered Glass, Steel
Dimensions (LxWxH)		650 x 306 x 651mm / 25.6 x 12.0 x 25.6inch
Motherboard Support		Mini-ITX, Micro-ATX, ATX, E-ATX (support upto 12" x 10.7")
Expansion Slots		8
Drive Bays	5.25"	1
	2.5"/3.5"	4 + 1 (in the accessory box)
	2.5" SSD	4
I/O Port		USB 3.1 Type-C x 1 USB 3.0 Type-A x 4 3.5mm Headset Jack (Audio+Mic) x 1 3.5mm Mic Jack x 1 Fan Speed & A-RGB Control Buttons
Pre-installed Fan(s)	Front	140mm PWM Fan x 3 (Speed: 1200RPM / Connector: 4Pin PWM)
	Rear	140mm PWM Fan x 1 (Speed: 1200RPM / Connector: 4Pin PWM)
Fan Support	Top	120/140mm fan x 3
	Front	120/140mm fan x 3
	Rear	120/140mm fan x 1
	Bottom	120/140mm fan x 2
Liquid Cooling Support	Top	120mm, 140mm, 240mm, 280mm, 360mm, 420mm (remove ODD, maximum thickness clearance 70mm)
	Front	120mm, 140mm, 240mm, 280mm, 360mm, 420mm (remove ODD)
	Rear	120mm, 140mm
	Bottom	120mm, 140mm, 240mm
	CPU Cooler	198mm
Clearances	GPU	490mm (without 3.5" HDD Bracket) 320mm (with 3.5" HDD Bracket)
Power Supply Support		Bottom Mount, ATX PS2

Package Content / Lieferumfang / Contenido de la confección / Contenu de l'emballage / Contenuto della confezione / Zawartość opakowania / Содержание комплекта / Съдържание / balení obsahuje / Περιεχόμενα συσκευασίας / A csomag tartalma / Verpakkinginhoud / Conteúdo da embalagem / Sadržajpakovanja / Paket İçeriği / 包装内含物品明細 / 包装内含物品清單 / パッケージ内容 / Isi Paket / 구성품 내용 / فهرست محتويات / محتوی الطرود

	Figure	Name	Q'ty	Used for
1		2-Bay ODD or Function Panel bracket	2	2-Bay 5.25" optical drive or function Panel
2		#6-32*6mm screw	17	2-Bay 5.25" optical drive or function panel bracket, PSU, motherboard
3		M3*5mm screw	8	5.25" optical drive
4		HDD screw	20	HDD cage
5		SSD screw	12	Mounting SSD on M.port cover
6		Stand-off	3	Motherboard tray
7		Stand-off socket	1	Motherboard stand-off installation
8		Cable Tie	10	Cable management
9		φ5*10mm screw	8	Installing fans
10		Cleaning Cloth	1	Cleaning glass
11		M3*4mm screw	20	SSD / mounting in SSD pockets
12		#6-32*6mm screw	2	Tap thread on frame holes
13		HDD SSD combo bracket	1	Install 3.5" devices
14		A-RGB splitter + Sata connector	1	Adding more A-RGB lighting Requires additional power source from SATA
15		Riser Cable	1	Connecting graphics card when using the rotateable graphics card holder

EN Front I/O & Buttons	HU Előlap I/O & kapcsolók
AR المنافذ الأمامية والأزرار	ID Tombol dan I/O depan
BG Преден панел и бутони	IT Pulsanti e I/O frontali
CHS 前面板接口及按键说明	JP フロント I/O パネル
CHT 前面板接口及按键说明	KR 전면 I/O & 버튼
CS Vstupy/Výstupy a další tlačítka na předním panelu	NL Bedieningspaneel
DE Front I/O & Tasten	PL Przedni panel I/O & Przyciski
EL Εμπρός I/O & διακόπτες	PT Botões e frontal I/O
ES Frontal I/O & Botones	RU Фронтальные кнопки и панель ввода/вывода
FA دکمه‌ها و درگاه‌های پهن جلو	SR Front I/O & Tasteri
FR Boutons sur le panneau E/S de façade	TR Ön I/O & Düğmeler

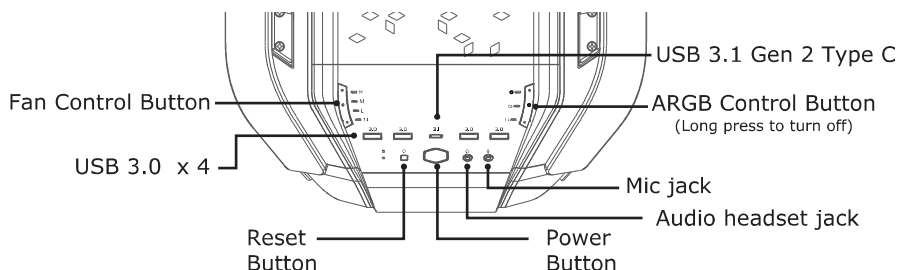

EN Compatibility	HU kompatibilitás
AR التوافق	ID Kompatibilitas
BG съвместимост	IT Compatibilità
CHS 相容性	JP パーツ互換性
CHT 兼容性	KR 호환성
CS kompatibilita	NL Compatibiliteit
DE Kompatibilität	PL Zgodność
EL Συμβατότητα	PT Compatibilidade
ES Compatibilidad	RU Совместимость
FA سازگاری	SR kompatibilnost
FR Compatibilité	TR Uyumluluk

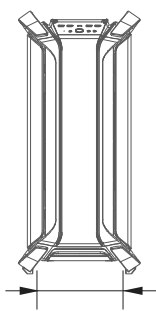

198 mm

Maximum height for CPU cooler

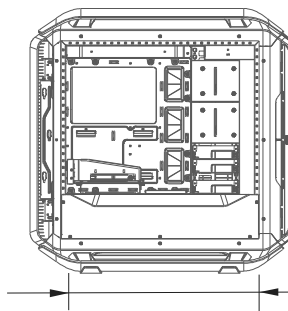

490 mm

Maximum length for Graphics card

Installation Guide / Installationsanleitung / Guía para la instalación / Guide d'installation / Guida per l'installazione / Instrukcja instalacji / Руководство пользователя / Ръководство за инсталация / Instalační příručka / Οδηγός εγκατάστασης / Telepítési útmutató / / Guia de instalação / Uputstvo za instalaciju / Kurulum Kılavuzu / 組裝說明 / 組裝說明 / 製品の使い方 / Panduan Instalasi / 설치 안내 / راهنمای نصب / دليل التثبيت

1

- | | | | |
|------------|-------------------------------------|-----------|-------------------------------------|
| EN | How to remove side panels | HU | Oldalsó panel eltávolítása |
| AR | كيفية إزالة اللوح الجانبى | ID | Cara melepaskan panel samping |
| BG | Как се отстранява страничният панел | IT | Come rimuovere il pannello laterale |
| CHS | 移除側板 | JP | サイドパネルの取り外し方法 |
| CHT | 移除側板 | KR | 사이드 패널 제거 방법 |
| CS | Jak odstranit boční kryt | NL | Verwijderen van het zijpaneel |
| DE | So entfernen Sie das Seitenpanel | PL | Jak zdjąć pokrywę boczną |
| EL | Πως να αφαιρέσετε το πλευρό κάλυμα | PT | Como remover o painel lateral |
| ES | Como extraer el panel lateral | RU | Как снять боковую панель |
| FA | نحوه باز کردن پنل کناری | SR | Kako da uklonite bočnu stranicu |
| FR | Comment retirer le panneau latéral | TR | Yan paneli kaldırma |

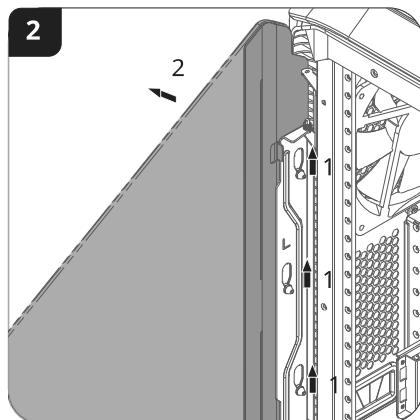
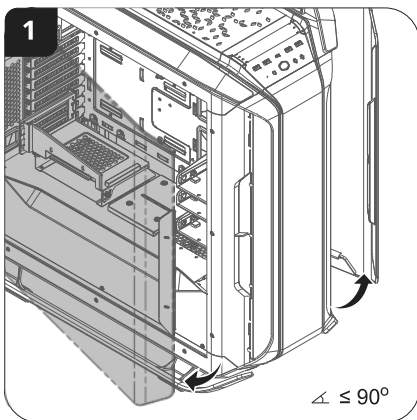

2

- | | | | |
|------------|---|-----------|--------------------------------------|
| EN | How to install power supply | HU | Tápegység beszerelése |
| AR | كيفية تثبيت موثر الطاقة | ID | Cara memasang power supply |
| BG | Как се поставя захранващият блок | IT | Come installare l'alimentatore |
| CHS | 安裝電源 | JP | 電源ユニットの取り付け方法 |
| CHT | 安裝電源 | KR | 파워 서플라이 설치 방법 |
| CS | Jak zapojit zdroj | NL | Installeren van de voeding |
| DE | So installieren Sie das Netzteil | PL | Jak podłączyć zasilanie |
| EL | Πως να εγκαταστήσετε το τροφοδοτικό | PT | Como instalar a fonte de alimentação |
| ES | Como instalar la fuente de alimentación | RU | Как установить блок питания |
| FA | نحوه نصب منبع تغذیه | SR | Kako da instalirate napajanje |
| FR | Comment installer l'alimentation | TR | Güç kaynağını kurma |

A Install regular PSU

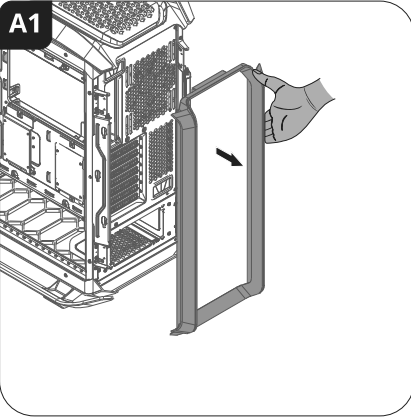

B Install longer PSU

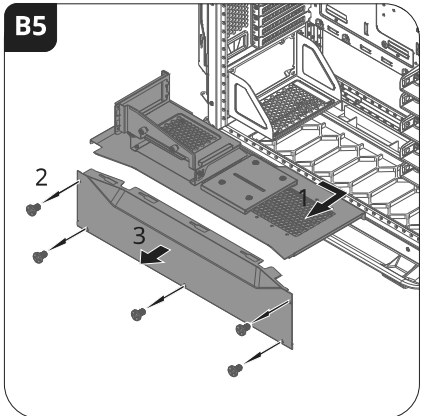
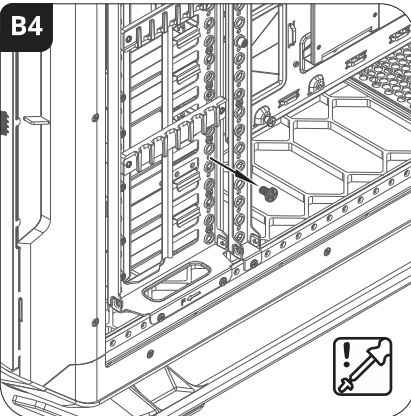
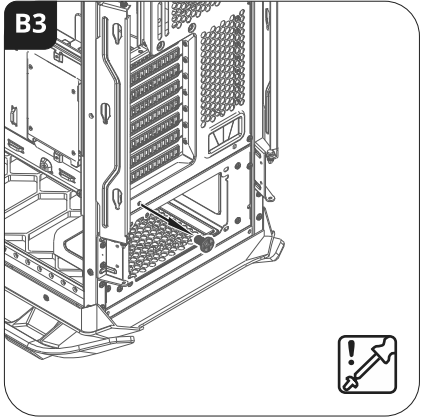
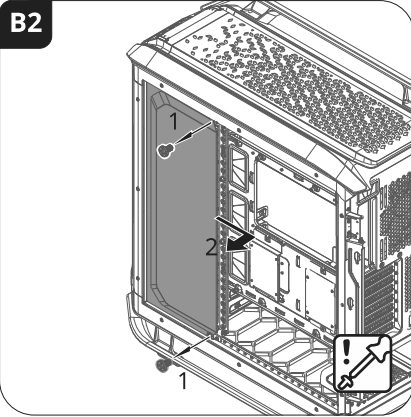
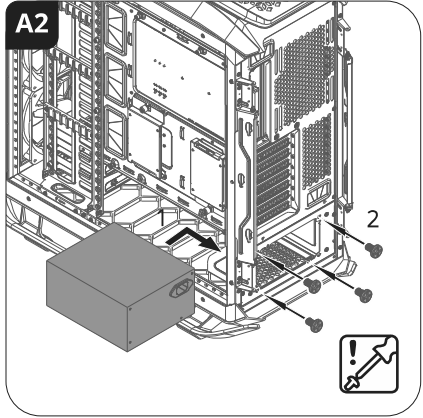

B6

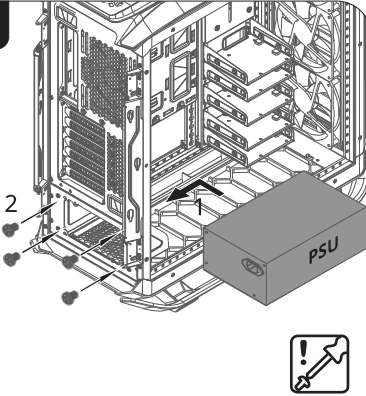

3

EN How to install motherboard

AR كيفية تثبيت اللوحة الأم

BG Как се инсталира дънната платка

CHS 安裝主板

CHT 安裝主機板

CS Jak nainstalovat motherboard

DE So installieren Sie das Motherboard

EL Πως να εγκαταστήσετε τη μητρική κάρτα

ES Como instalar la placa base

FA نحوه نصب مادربرد

FR Comment installer la carte mère

HU Alaplap beszerelése

ID Cara memasang motherboard

IT Come installare la motherboard

JP マザーボードの取り付け方法

KR 마더보드 설치 방법

NL Installeren van het moederbord

PL Jak zamontować płytę główną

PT Como instalar a placa-mãe

RU Как установить материнскую плату

SR Kako da instalirate matičnu ploču

TR Anakartı kurma

A Internal installation (for ATX)

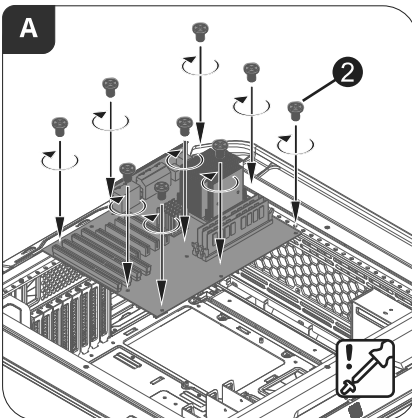

B External installation (for ATX)

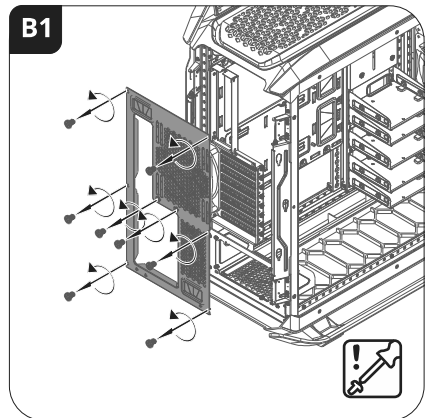

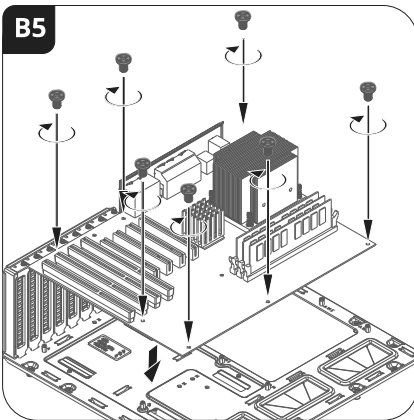
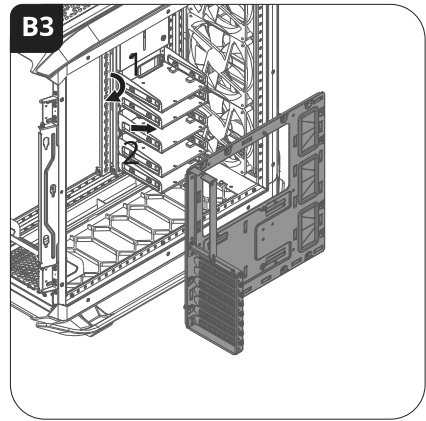
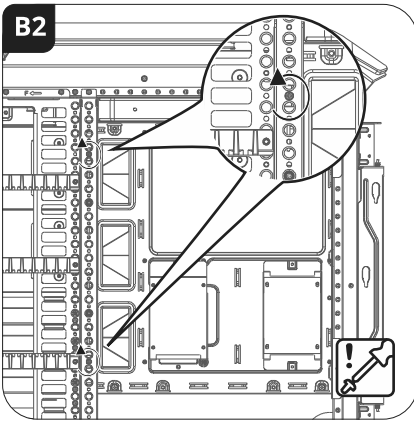

For other motherboard sizes please refer to motherboard manual. You may need to remove 1 or more the pre-installed stand-offs for proper installation.

4

- | | |
|--|--|
| [EN] How to remove/install GFX bracket & SSD bracket | [HU] Hogyan telepítsük/távolítsuk el a GFX és SSD keretet |
| [AR] قرص و الرسوميات بطاقة حامل فك و تركيب طريفة SSD | [ID] Cara Instalasi / Melepas Braket GFX & Braket SSD |
| [BG] Как се монтира/премахваат скобите за графична карта и SSD. | [IT] Come installare / rimuovere la staffa GFX e la staffa SSD |
| [CHS] 安裝/拆卸显卡支架和SSD支架 | [JP] グラフィックスカードブラケットおよびSSDブラケットの取付け/取外しの仕方 |
| [CHT] 安裝/拆卸顯示卡支架和SSD支架 | [KR] GFX 브라켓 및 SSD 브라켓 설치 / 제거 방법 |
| [CS] Jak nainstalovat / odebrat držák GFX a držák SSD | [NL] Installeren/verwijderen van videokaart bracket & SSD bracket |
| [DE] Ein-/Ausbau von Grafikkarten-Halterung und SSD-Halterung | [PL] Jak zamontować/usunąć ramkę GFX i SSD |
| [EL] Πώς να εγκαταστήσετε / αφαιρέσετε το GFX bracket & SSD bracket | [PT] Como instalar/remover os brackets GFX e SSD |
| [ES] Cómo instalar / extraer el soporte GFX y el soporte SSD | [RU] Как установить/удалить кронштейн GFX и кронштейн SSD. |
| [FA] SSD و کی-گراف کارت برکت یساز جدا و نصب یچگونگ | [SR] Kako instalirati/ukloniti GFX nosač & SSD nosač |
| [FR] Comment installer / retirer le support pour carte graphique et le support pour SSD | [TR] GFX ve SSD Desteği Nasıl Takılır/Çıkartılır |

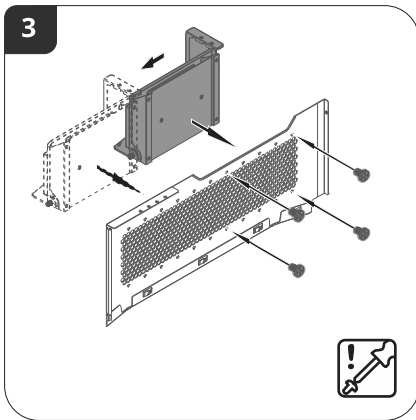
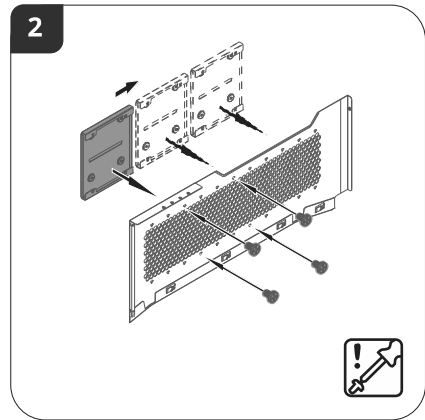
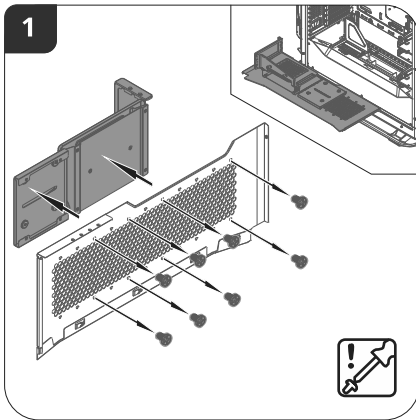

5

[EN] How to install add-on cards

[AR] كيفية تثبيت بطاقات مضافة

[BG] Как се инсталират допълнителните платини

[CHS] 安装显卡

[CHT] 安裝顯示卡

[CS] Jak nainstalovat přídatné karty

[DE] So installieren Sie Erweiterungskarten

[EL] Πως να εγκαταστήσετε πρόσθετες κάρτες

[ES] Como instalar tarjetas adicionales

[FA] نحوه نصب کارت‌ها

[FR] Comment installer les cartes supplémentaires

[HU] Add-on kártyák beszerelése

[ID] Cara memasang perangkat kartu tambahan

[IT] Come installare le schede aggiuntive

[JP] 拡張カードの取り付け方法

[KR] 애드 온 카드 설치 방법

[NL] Installeren van de extra kaarten

[PL] Jak podłączyć karty rozszerzeń

[PT] Como instalar as placas adicionais

[RU] Как установить карты расширения

[SR] Kako da instalirate dodatne kartice

[TR] Eklenli kartlarını kurma

A Regular position

B Install on midplate

C Install on M.Port

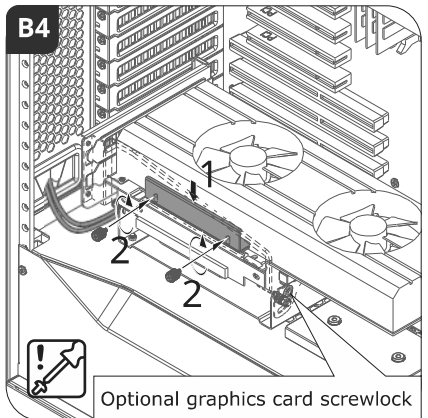
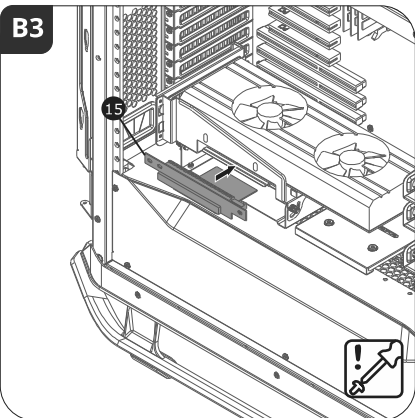
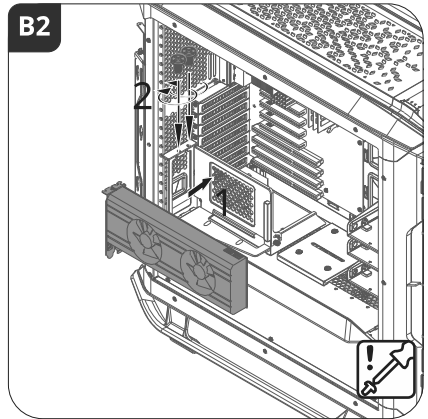
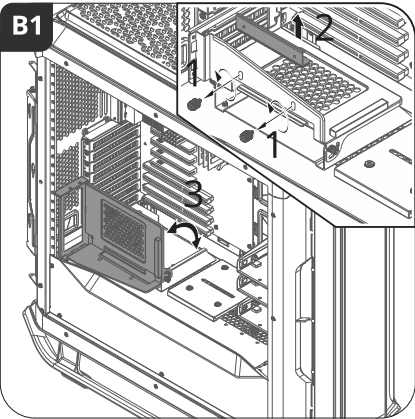
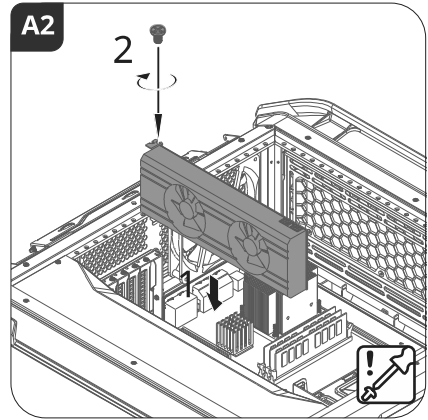
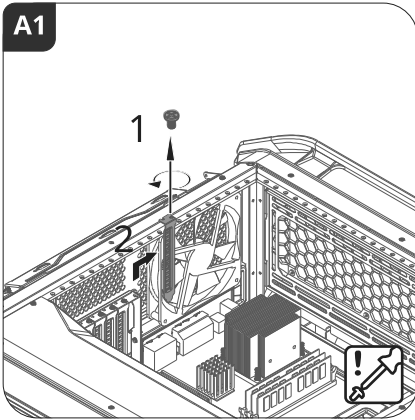

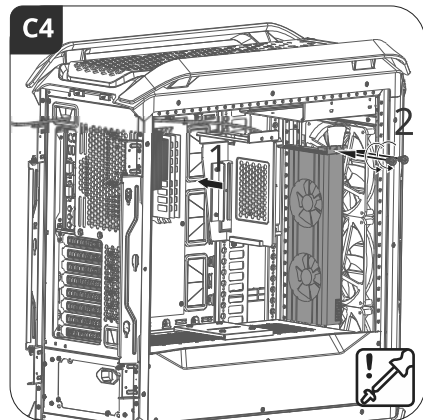
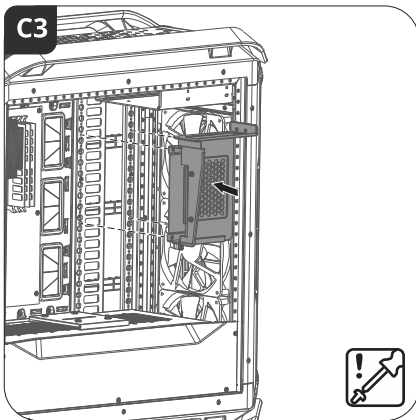
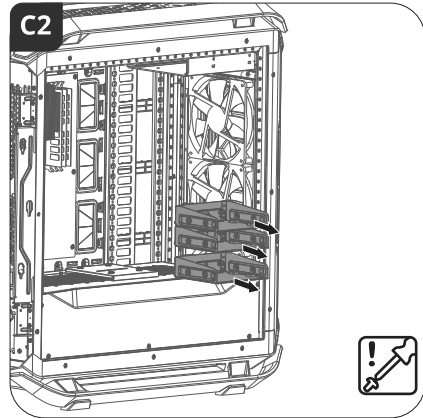
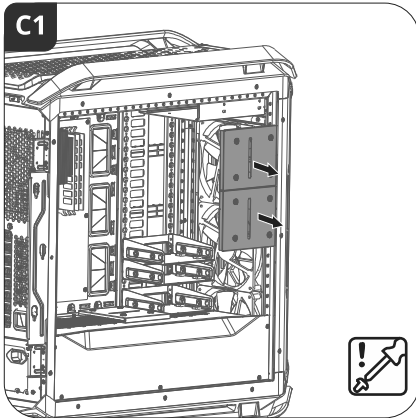

6

- [EN]** How to install 5.25" devices
- [AR]** كيفية تثبيت الأجهزة مقاس 5.25 بوصة
- [BG]** Как се инсталират 5,25" устройствата
- [CHS]** 安裝5.25"裝置
- [CHT]** 安裝5.25"裝置
- [CS]** Jak nainstalovat zařízení 5.25"
- [DE]** So installieren Sie 5.25" Zoll Geräte
- [EL]** Πως να εγκαταστήσετε τις συσκευές 5,25"
- [ES]** Como instalar los dispositivos de 5,25"
- [FA]** نحوه نصب درایوهای 5.25 اینچ
- [FR]** Comment installer les périphériques 5,25 pouces

- [HU]** 5,25" eszközök beszerelése
- [ID]** Cara memasang perangkat 5.25
- [IT]** Come installare le unità da 5.25"
- [JP]** 5.25"インチデバイス (光学ドライブなど)の取り付け方法
- [KR]** 5.25인치 장치 설치 방법
- [NL]** Installeren van de 5.25" apparaten
- [PL]** Jak zamontować urządzenia 5.25"
- [PT]** Como instalar os dispositivos de 5,25"
- [RU]** Как установить 5,25" устройства
- [SR]** Kako da instalirate 5,25" uređaje
- [TR]** 5,25" aygıtları kurma

A Install 1x 5.25" optical drive

B Install 2x 5.25" optical drive

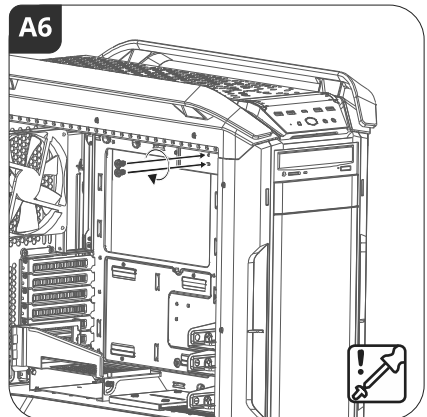
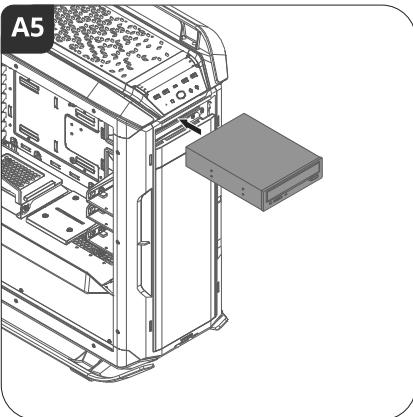
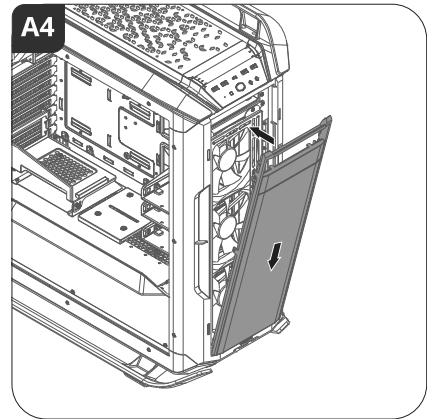
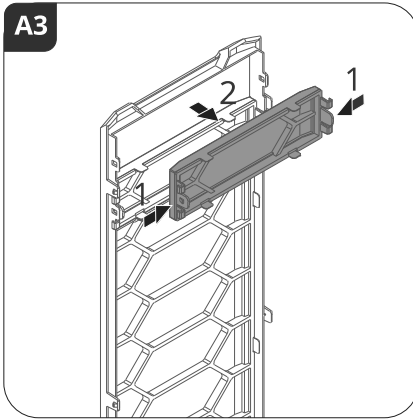
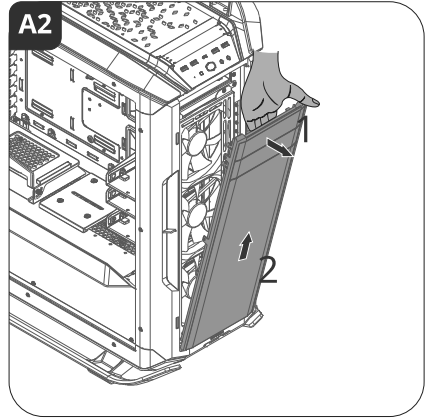
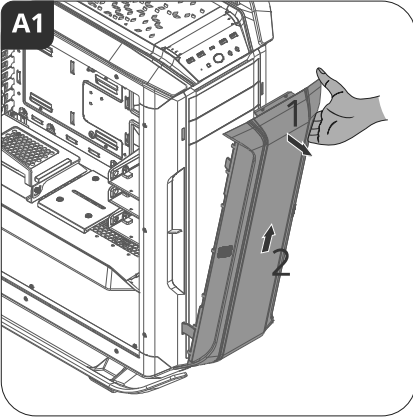

B1

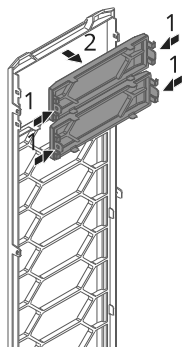

B2

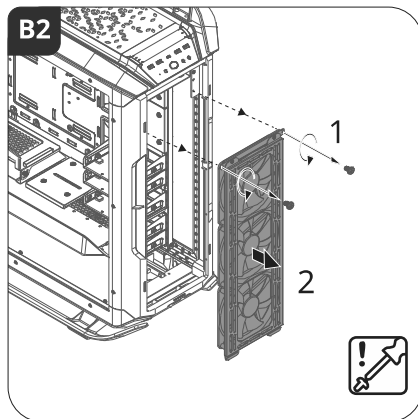

B3

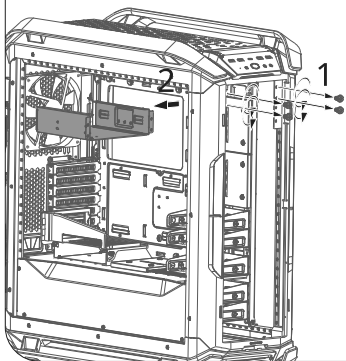

B4

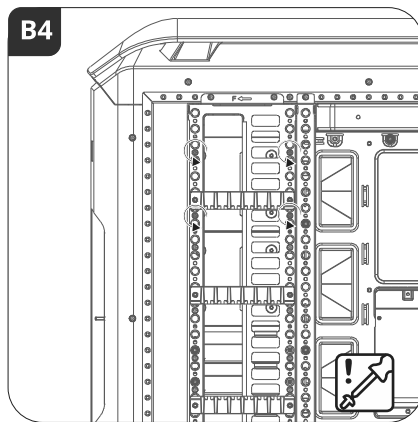

B5

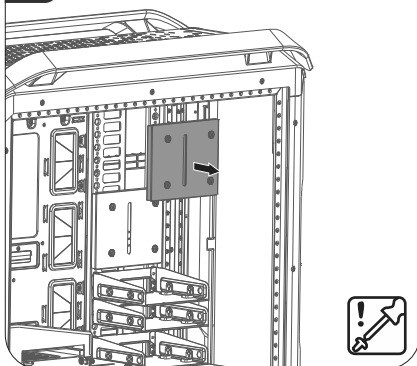

B6

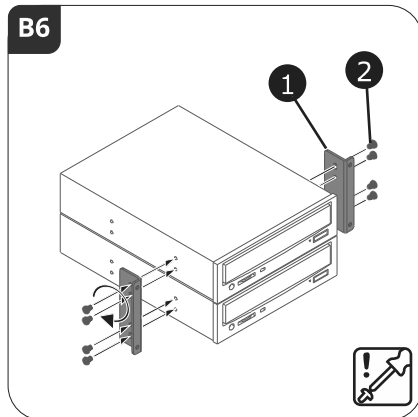

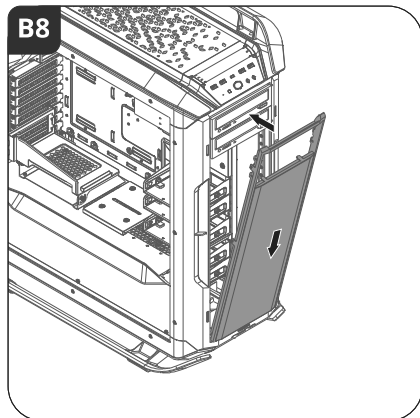
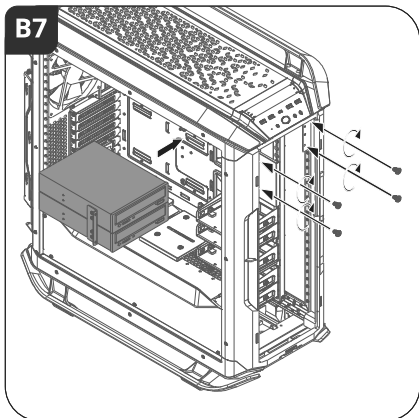

7

- EN** How to install 3.5" devices
- AR** كيفية تثبيت القرص الصلب مقاس 3.5" بوصة
- BG** Как се инсталират 3.5" устройствата
- CHS** 安装3.5"装置
- CHT** 安裝3.5"裝置
- CS** Jak nainstalovat zařízení 3.5"
- DE** So installieren Sie 3,5 Zoll Geräte
- EL** Πώς να εγκαταστήσετε τις συσκευές 3.5"
- ES** Como instalar los dispositivos de 3.5"
- FA** نحوه نصب درایوهای 3.5 اینچ
- FR** Comment installer les périphériques 3.5 pouces

- HU** 3.5" eszközök beszerelése
- ID** Cara memasang perangkat 3.5
- IT** Come installare le unità da 3.5"
- JP** 3.5インチデバイス (HDDなど) の取り付け方法
- KR** 3.5인치 하드 디스크 드라이브 설치 방법
- NL** Installeren van de 3.5" apparaten
- PL** Jak zamontować urządzenia 3.5 "
- PT** Como instalar os dispositivos de 3,5"
- RU** Как установить 3,5" устройства
- SR** Kako da instalirate 3,5" uređaje
- TR** 3,5" aygıtları kurma

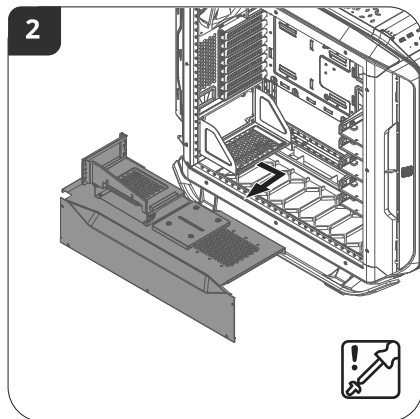
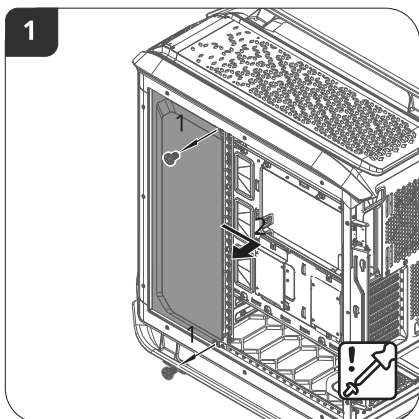

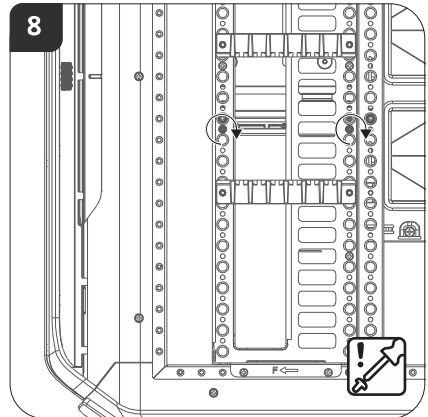
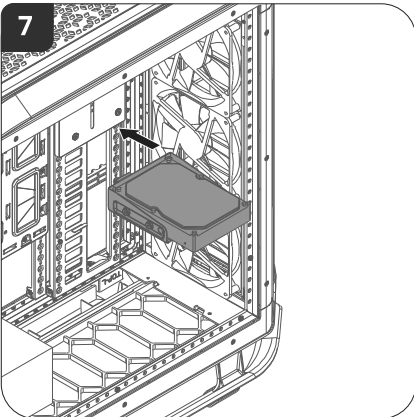
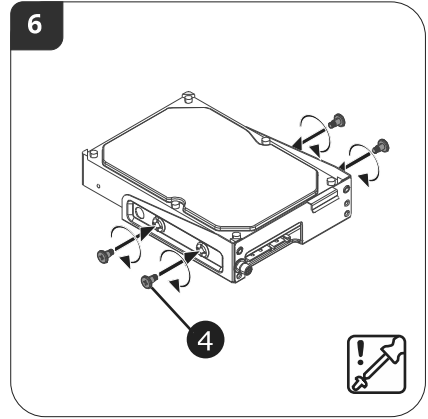
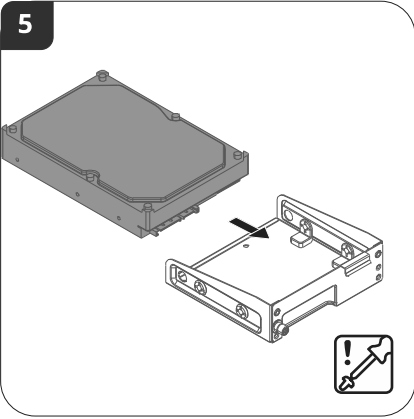
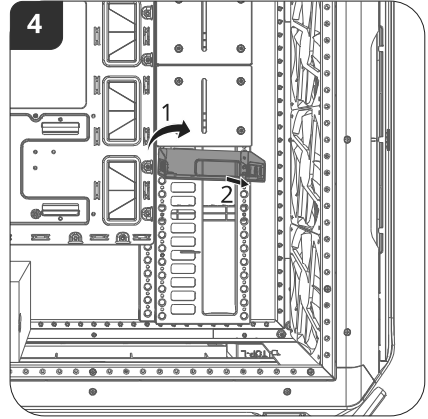
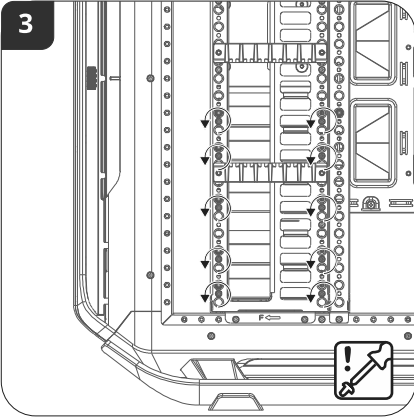

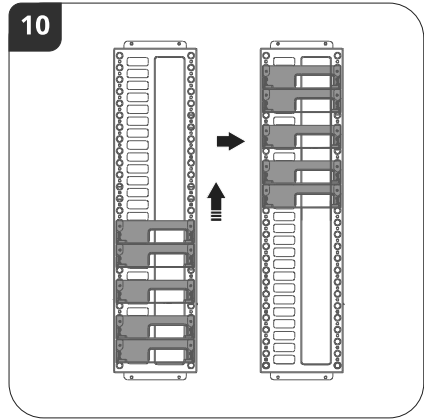
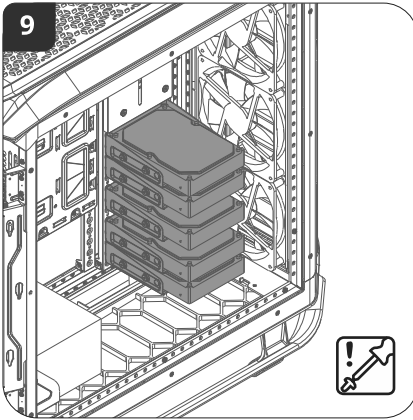

8

- [EN] How to install 2.5" devices
- [AR] كيفية تثبيت القرص الصلب مقاس 2.5 بوصة
- [BG] Как се инсталират 2.5" устройствата
- [CHS] 安裝2.5"裝置
- [CHT] 安裝2.5"裝置
- [CS] Jak nainstalovat zařízení 2.5"
- [DE] So installieren Sie 2,5 Zoll Geräte
- [EL] Πως να εγκαταστήσετε τις συσκευές 2.5"
- [ES] Como instalar los dispositivos de 2.5"
- [FA] نحوه نصب درایوهای 2.5 اینچ
- [FR] Comment installer les périphériques 2.5 pouces

- [HU] 2.5" eszközök beszerelése
- [ID] Cara memasang perangkat 2.5"
- [IT] Come installare le unità da 2.5"
- [JP] 2.5インチデバイス (SSDなど) の取り付け方法
- [KR] 2.5인치 하드 디스크 드라이브 설치 방법
- [NL] Installeren van de 2.5" apparaten
- [PL] Jak zamontować urządzenia 2.5"
- [PT] Como instalar os dispositivos de 2,5"
- [RU] Как установить 2,5" устройства
- [SR] Kako da instalirate 2,5" uređaje
- [TR] 2,5" aygıtları kurma

A Installation behind motherboard tray

B Installation on M.Port

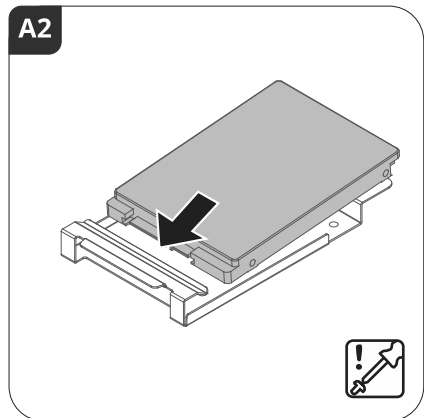
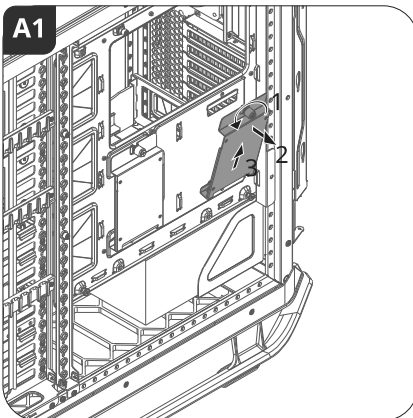

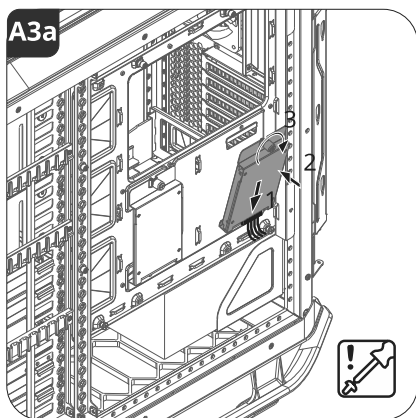

OR

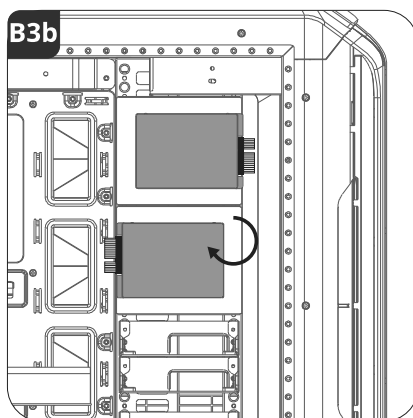
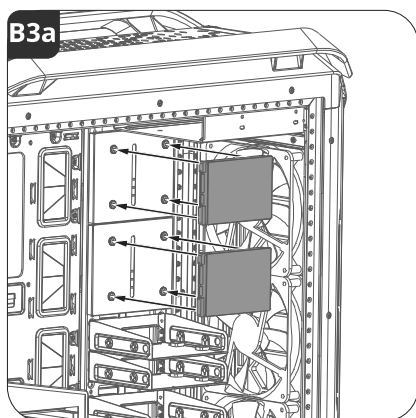
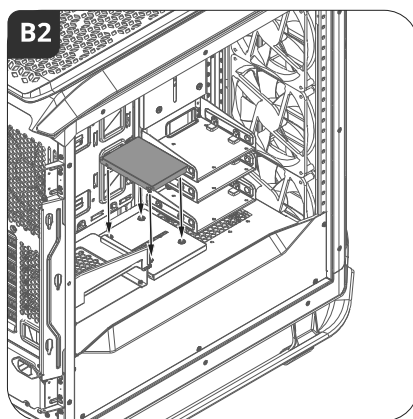
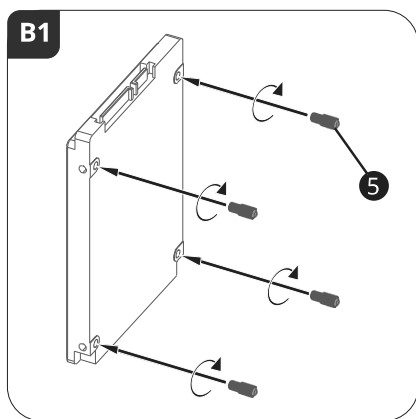
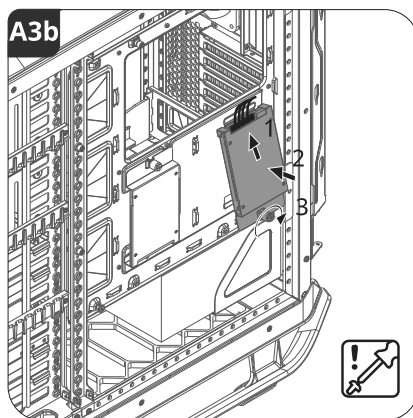

9

- EN** How to install case fans and radiators
- AR** كيفية تركيب المراوح و المبرد
- BG** Как се инсталират радиатори и вентилатори
- CHS** 安裝風扇和水冷排
- CHT** 安裝風扇和水冷排
- CS** Jak nainstalovat ventilátory a chladiče
- DE** So installieren Sie Lüfter und Radiatoren
- EL** Πώς να εγκαταστήσετε ανεμιστήρες και ψυγεία
- ES** Como instalar ventiladores de caja y radiadores
- FA** نحوه نصب رادیاتور ها و فن های کیس
- FR** Comment installer les ventilateurs et radiateurs

- HU** Ventilátorok és a radiátorok beszerelése
- ID** Cara memasang kipas kasus dan radiator
- IT** Come Installare ventole e radiatori
- JP** ケースファンとラジエーターの取り付け方法
- KR** 케이스 팬 및 라디에이터 설치 방법
- NL** Installeren van de ventilatoren en radiatoren
- PL** Jak zamontować wentylatory i radiatory
- PT** Como instalar as ventoinhas e os radiadores
- RU** Как установить корпусные вентиляторы и радиаторы
- SR** Kako da instalirate ventilatore i radijatore
- TR** Kasa fanlarını ve radyatörleri takmak

A Install on top

B Install in front

C Install in bottom

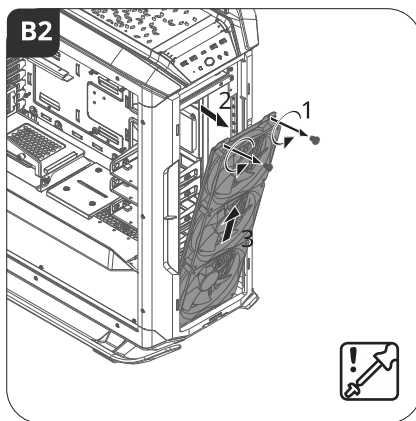
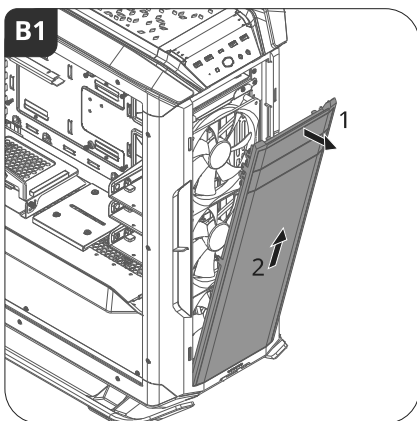
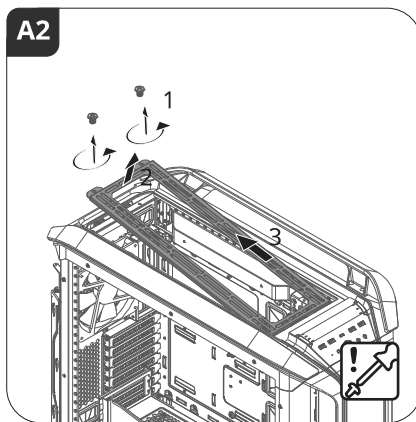
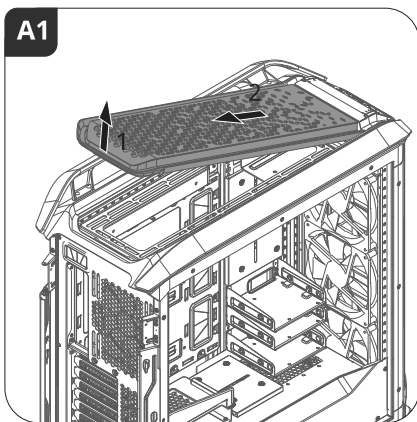

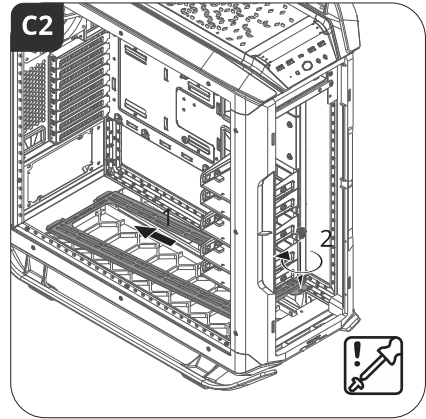
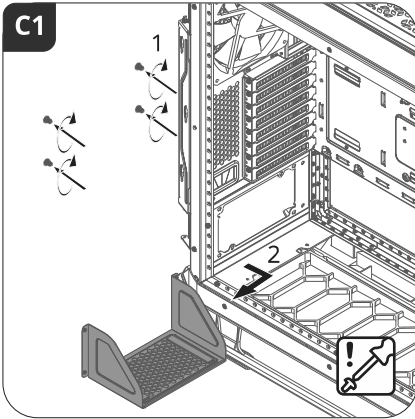

10

- EN** How to install 420mm radiator
- AR** كيفية تركيب المراو 420mm المبرد
- BG** Как да инсталирате 420 мм радиатор
- CHS** 安裝420mm水冷排
- CHT** 安裝420mm水冷排
- CS** Jak nainstalovat chladič o průměru 420 mm
- DE** So installieren Sie 420mm Radiator
- EL** Πώς να εγκαταστήσετε ψυγείο 420mm
- ES** Cómo instalar un radiador de 420mm
- FA** نحوه نصب رادیاتور 420 میل‌متری
- FR** Comment installer un radiateur de 420 mm

- HU** 420mm radiátor felszerelése
- ID** Cara memasang radiator 420mm
- IT** Come installare radiatore da 420mm
- JP** 420mmラジエーターの取り付け方法
- KR** 420mm 라디에이터 설치 방법
- NL** Installeren van de 420mm radiator
- PL** Jak zainstalować chłodnicę 420 mm
- PT** Como instalar o radiador de 420mm
- RU** Как установить радиатор 420 мм
- SR** Kako da instalirate 420mm radijator
- TR** 420mm Radyatörü takmak

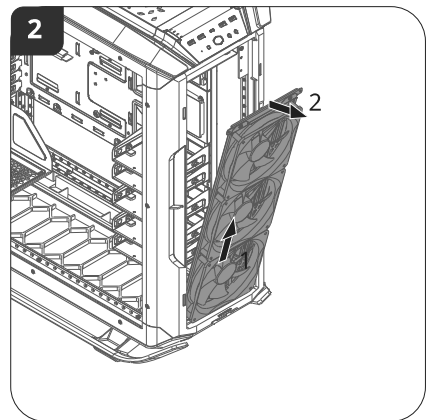
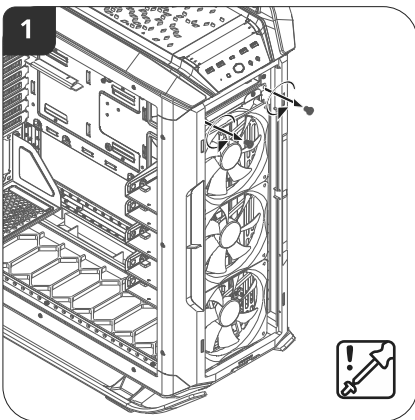

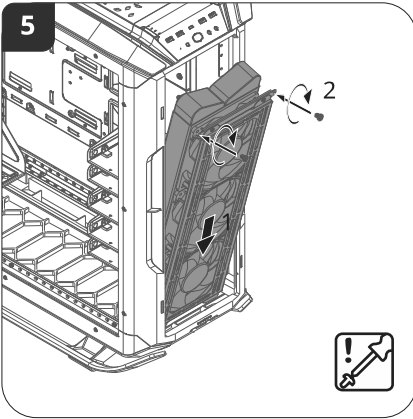
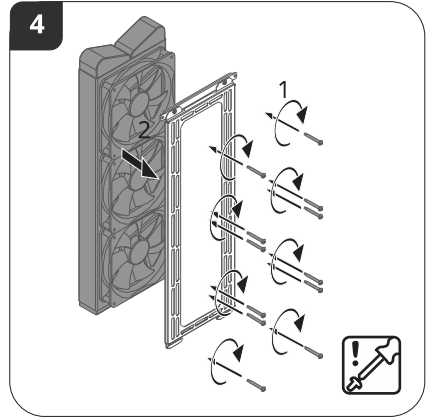
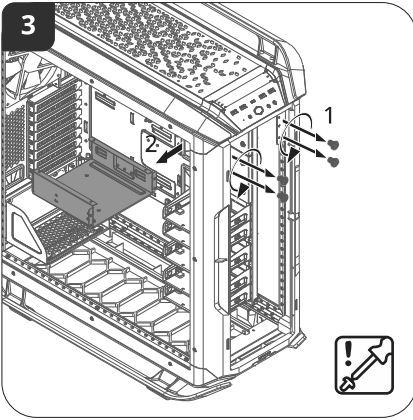

Fan

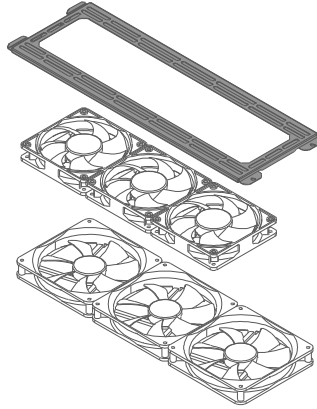

Radiator

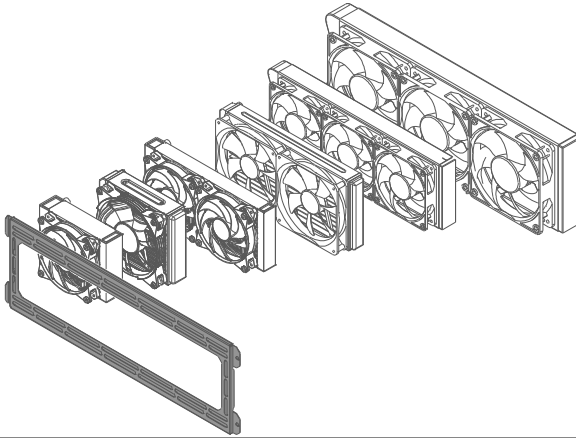

	Position	Support
Fan	Top	120/140mm x 3
	Front	120/140mm x 3
	Bottom*	120/140mm x 2
Radiator	Top	120mm, 140mm, 240mm, 280mm, 360mm/420mm (requires removal of 5.25" Optical drive Cage)
	Front	120mm, 140mm, 240mm, 280mm, 360mm, 420mm (requires removal of 5.25" Optical drive Cage)
	Bottom*	120mm, 140mm, 240mm, 360mm (requires alternative PSU location)

For all 3 positions it requires the purchase of an additional cooling bracket.

11

- [EN] How to install radiator in the rear
- [AR] كيفية تركيب المبرد في الخلف
- [BG] Как се инсталира радиатор в задния панел
- [CHS] 安裝後方水冷排
- [CHT] 安裝後方水冷排
- [CS] Jak nainstalovat chladič vzadu
- [DE] So installieren Sie einen Radiator am Heck
- [EL] Πώς να εγκαταστήσετε ψυγείο στο πίσω μέρος
- [ES] Como instalar el radiador en a parte posterior
- [FA] نحوه نصب رادیاتور در قسمت پشتی
- [FR] Comment installer le radiateur à l'arrière
- [HU] Radiátor beszerelésé hátulra
- [ID] Cara memasang radiator bagian belakang
- [IT] Come installare un radiatore nella sezione posteriore
- [JP] 後部にラジエーター 取り付け方法
- [KR] 뒤쪽에 라디에이터를 설치하는 방법
- [NL] Installeren van de radiator aan de achterkant
- [PL] Jak zamontować radiator na tylnej ścianie
- [PT] Como instalar o radiador na traseira
- [RU] Как установить радиатор в задней части корпуса
- [SR] Kako instalirati radiator u zadnjem delu
- [TR] Radyatörü arkaya takmak

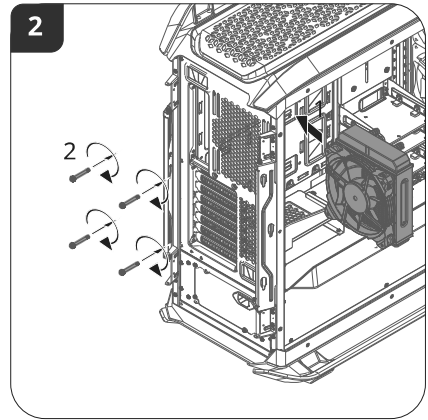
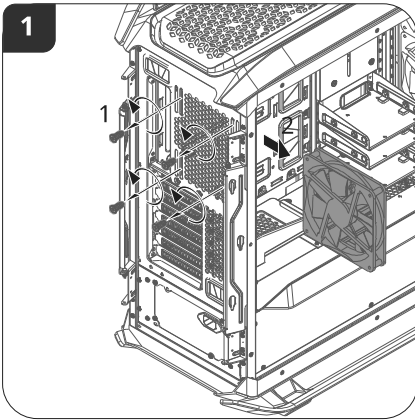

12

- [EN] Cable management
- [AR] تنظيم الأسلاك
- [BG] Кабел мениджмънт
- [CHS] 线缆整理
- [CHT] 線纜整理
- [CS] Cable management
- [DE] Kabel-management
- [EL] Διαχείριση καλωδίων
- [ES] Gestión de cable
- [FA] مدیریت کابل
- [FR] Gestion des câbles
- [HU] Kábel menedzsment
- [ID] Manajemen Kabel
- [IT] Cable Management
- [JP] 配線収納
- [KR] 케이블 관리
- [NL] Kabel management
- [PL] Zarządzanie kablami
- [PT] Gestão de cabos
- [RU] Кабель менеджмент
- [SR] Pozicioniranje kablova
- [TR] Kablo Yönetimi

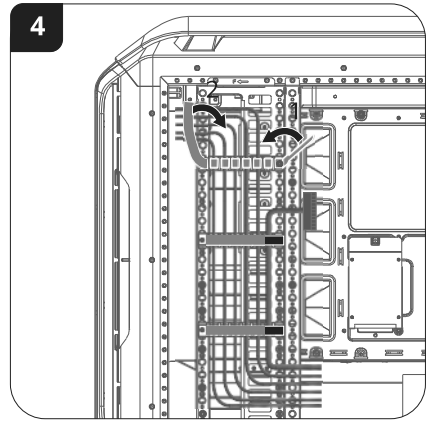
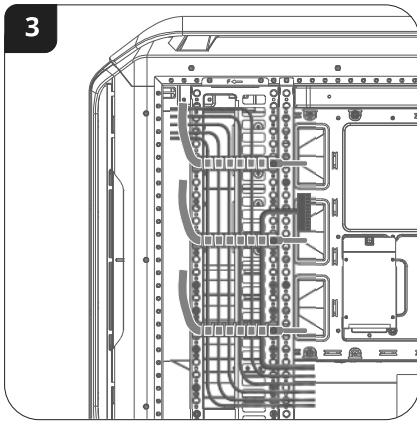
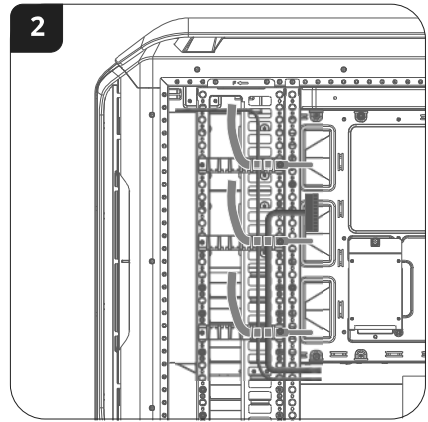
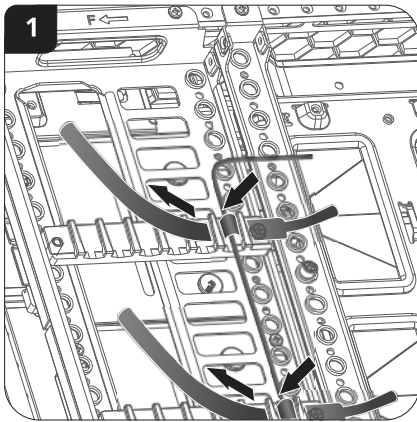

13

EN Completing installation

AR استكمال التثبيت

BG Завършване на инсталацията

CHS 完成組裝

CHT 完成組裝

CS Dokončení instalace

DE So schliessen Sie die Installation ab

EL Ολοκλήρωση εγκατάστασης

ES Completar la instalación

FA تکمیل نصب

FR Terminer l'installation

HU A szerelés befejezése

ID Menyelesaikan Instalasi

IT Completamento dell'installazione

JP 完成図

KR 설치 완료

NL Installatie voltooid

PL Kończenie instalacji

PT Finalizar a instalação

RU Завершение сборки

SR Dovršavanje instalacije

TR Kurulum tamamlanıyor

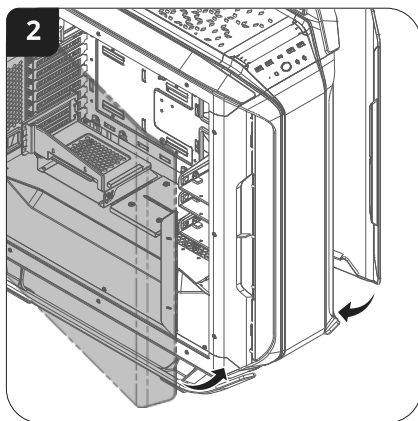
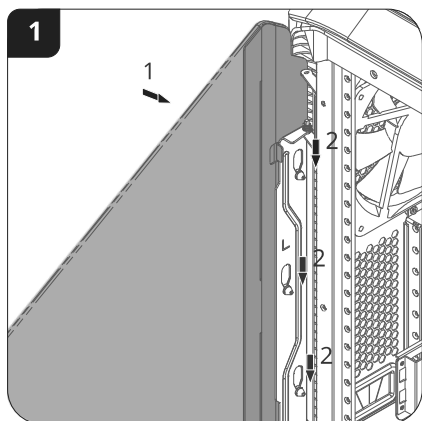

Fan & A-RGB controller operation / Lüfter und A-RGB Steuerung / Funcionamiento del ventilador y del controlador A-RGB / Fonctionnement du contrôleur d'éclairage A-RGB et de ventilateurs / Funcionamento del controller Ventola& A-RGB / Obsługa kontrolera wentylatorów i podświetlenia A-RGB / Управление контроллера вентилятора и A-RGB / Как функционира контролер вентилатор и A-RGB / Ovládání ventilátoru a A-RGB / Χρήση ελεγκτή fan & A-RGB / Ventilátor és A-RGB vezérlő kezelése / Ventilator & A-RGB controller bediening / Funcionamento do controlador das ventoinhas e A-RGB / Funkcija ventilatora i A-RGB kontrolera / Fan & A-RGB kontrolcü işlemleri / 風扇和A-RGB燈光控制操作 / 風扇和A-RGB灯光控制操作 / ファンとA-RGBコントローラー操作説明 / Pengontrol operasional kipas danA-RGB / 팬 및 A-RGB 컨트롤러 작동 / متحكم المراوح و إضاءة A-RGB / A-RGB / عملکرد کنترلر فن و A-RGB

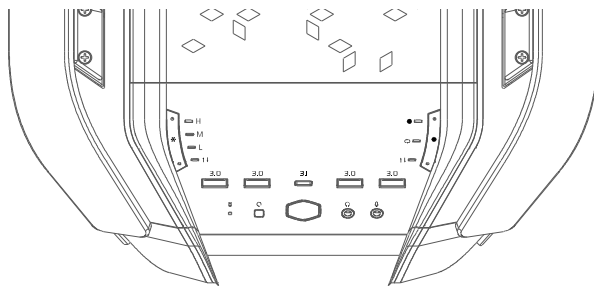

	Mode	Description
(✳) Fan controller	(H) High	Fan operates at 100%
	(M) Medium	Fan operates at 75%
	(L) Low	Fan operates at 50%
	(↑ ↓) M/B sync	Motherboard sync (PWM input)
(☼) Addressable RGB controller	(☼) Static	7 preset colors
	(🔄) Cycle	4 preset dynamic color cycles
	(↑ ↓) M/B sync*	Sync up with motherboard lighting

*M/B sync mode only works when connecting control board to motherboard A-RGB header. Do NOT connect to regular RGB header!

Control Board Layout / Layout der Steuerplatine / Diseño de la tarjeta de control / Disposition de la carte de contrôle / Layout della scheda di controllo / Układ panelu sterowania / Панель управления / Карта на контролния панел / Rozložení ovládací desky / Διάταξη του control board / Kezelő lap kiosztása / Ventilator & RGB aansluit schema / Layout do kontrolador da board / Šema kontrolne ploče / Kontrol kartı şeması / 控制板接口 / 控制板接口 / コントロールボードレイアウト / Susunan Papan Kontrol / 컨트롤 보드 레이아웃 / طرح مدار کنترل / لوحة التحكم

طرح مدار کنترل / لوحة التحكم

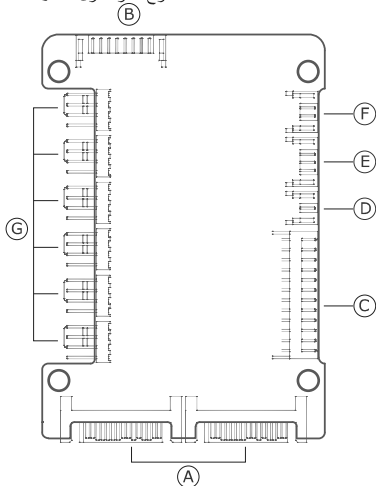

	Connector Name	Description
A	SATA power connector	2 x SATA 15-pin power connectors are required to provide power input to the control board (1)
B	Front panel control connector	Connects to IO panel
C	A-RGB Lighting connector	Total 4 channels,max 2A output per channel, total 8A output for all A-RGB out put (2)
D	MB A-RGB sync connector	Connect to motherboard A-RGB sync port
E	USB connector	Connect to motherboard USB2.0 port for controller Firmware upgrade
F	MB FAN sync connector	Connect to motherboard FAN port
G	Fan Connectors	FAN1~FAN6 4pin PWM FAN connector(compatible with 3pin FAN),0.4A output channel and 2.4A total



(1) Minimum 18AWG thickness PSU wires required as current may exceed 6A.

(2) 3 channels for pre-installed lighting on case.

1 channel for additional A-RGB devices. Connect via splitter with SATA to supply power.

I/O connectors / I/O Anschlüsse / Conectores I/O / Connecteurs E/S / Connettori I/O / Złącza panelu I/O / Разъёмы ввода/вывода / Интерфейсни конектори / Vstup/Výstup / Συνδέσεις I/O / I/O csatlakozók / I/O connectoren / Conectores I/O / I/O konektori / I/O bağlantıları / I/O面板接頭 / I/O面板接头 / I/Oコネクタ / Konektor I/O / I / O 커넥터 / موصلات المنافذ / کنکتورهای I/O

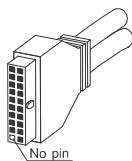
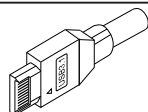
- [EN] Please follow motherboard manual instruction for connection.
- [AR] يرجى إتباع دليل استخدام اللوحة الرئيسية لتكريب التوصيلات
- [BG] Моля следвайте инструкциите на дънната платка за инсталация
- [CHS] 请遵照主板安装手册进行连接
- [CHT] 請遵照主機板安裝手冊進行連接
- [CS] Pro připojení využijte návod dodaný k základní desce
- [DE] Für die Anschlüsse bitte die Bedienungsanleitung des Mainboards lesen
- [EL] Ακολουθήστε τις οδηγίες την μητρικής κάρτας για την σύνδεση.
- [ES] Siga las instrucciones del manual de la placa base para la conexión.
- [FR] Veuillez vous reporter au manuel de la carte mère pour les instructions de branchement
- [HU] Kövesd az alaplap útmutatóját a helyes csatlakoztatáshoz.
- [ID] Mohon mengikuti instruksi manual motherboard untuk koneksi
- [IT] Seguire le istruzioni della scheda madre per la connessione.
- [JP] マザーボードの取り付け方法
- [KR] 연결을 위해 마더보드 매뉴얼 지시를 따르십시오.
- [NL] Volg de handleiding van het moederbord voor installatie
- [PL] Przy podłączaniu kieruj się instrukcją obsługi płyty głównej
- [PT] Por favor siga o manual da motherboards para as conexões
- [RU] Для подключения, пожалуйста, следуйте инструкциям материнской платы.
- [SR] Molimo vas da pratite uputstva matične ploče za povezivanje.
- [TR] Bağlantılar için lütfen anakart kullanma kılavuzuna bakınız

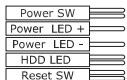
Case Connector
USB 3.0 connector

USB 3.1 connector

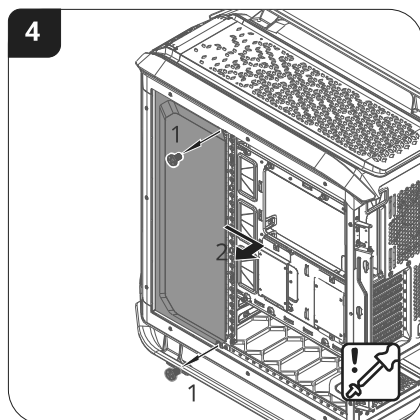
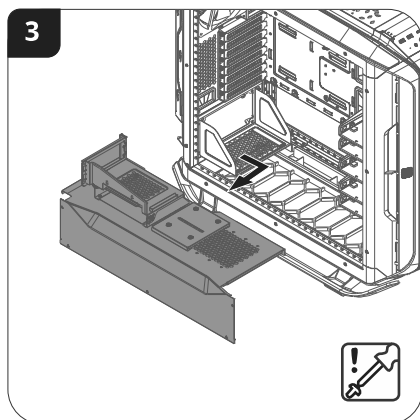
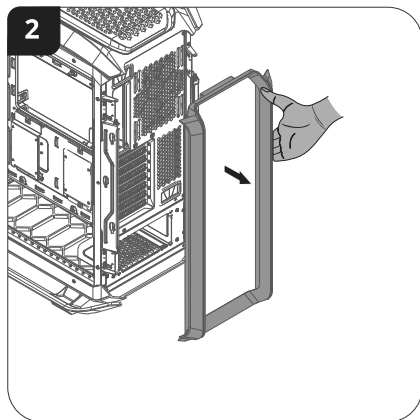
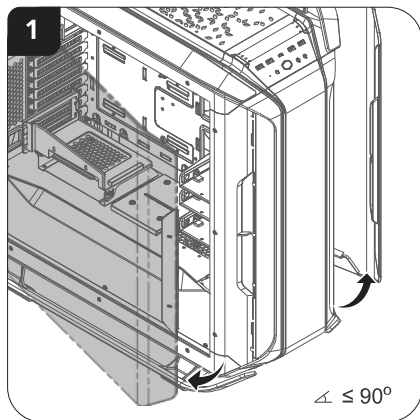
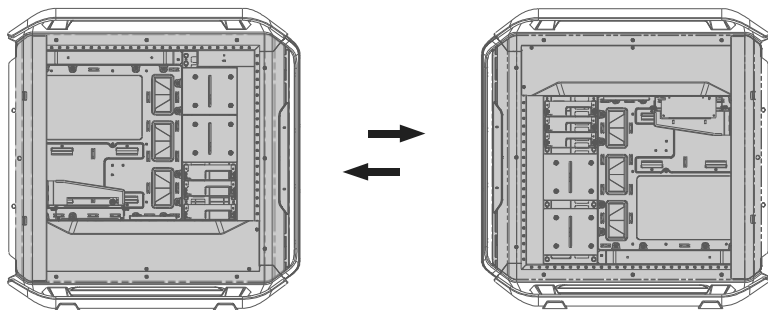
HD Audio connector

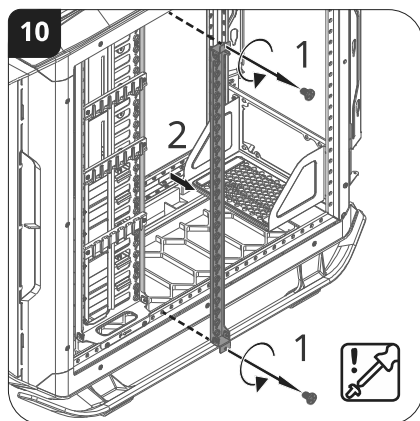
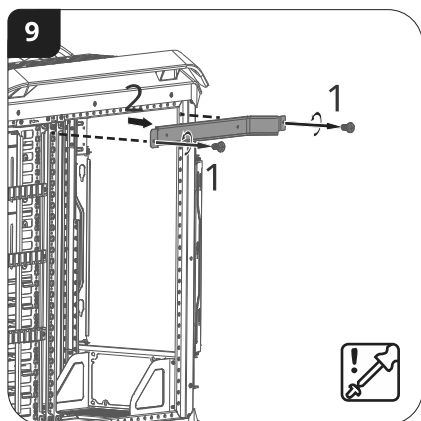
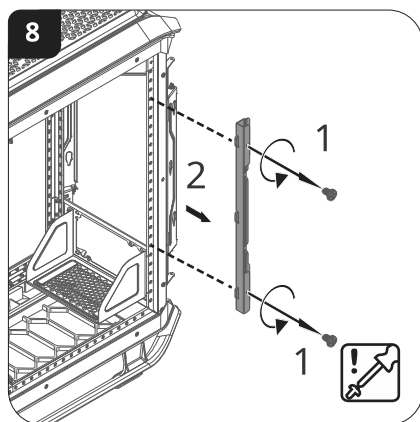
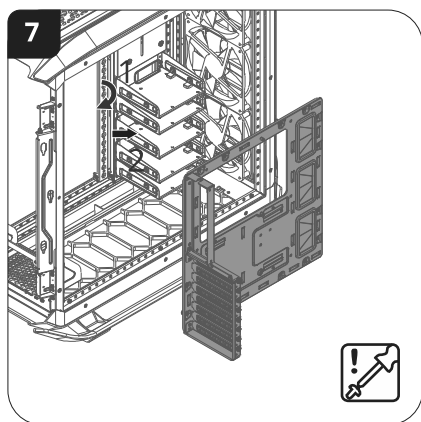
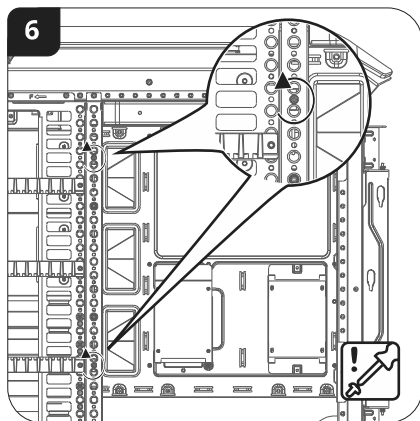
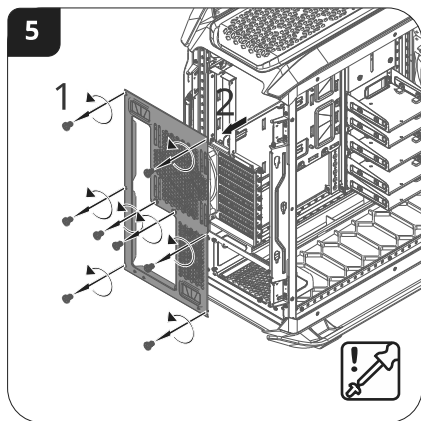
Power SW/ LED, HDD LED Reset SW

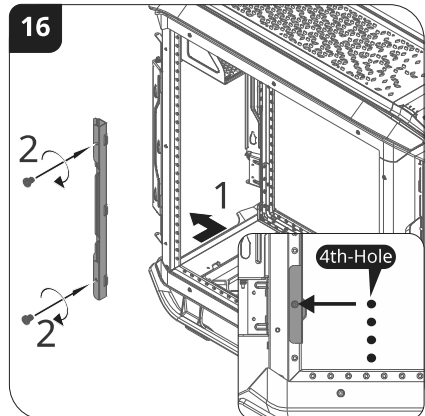
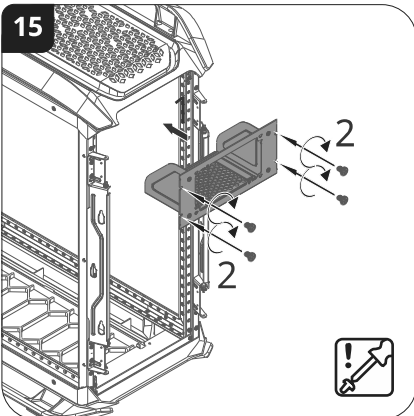
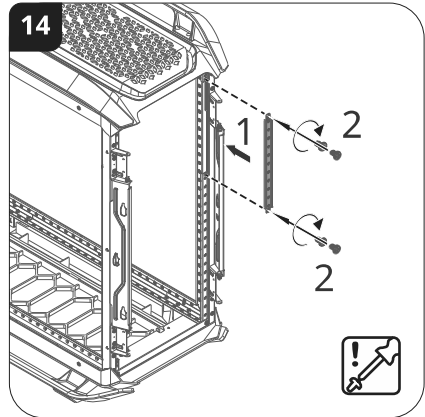
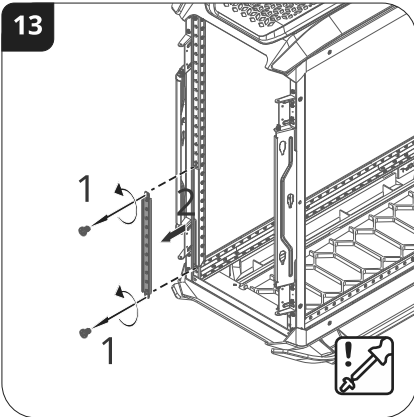
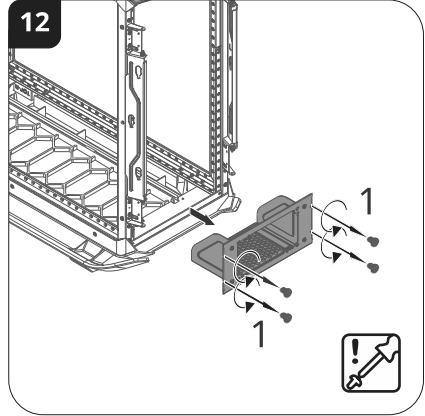
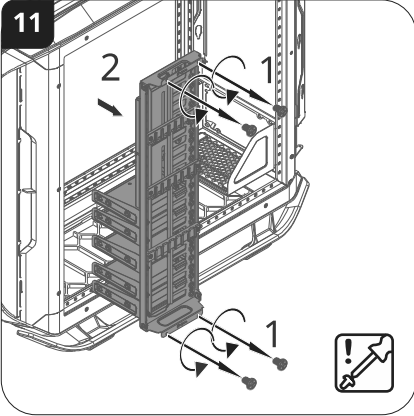
Inverse layout adjustment / Anpassung des Layouts: Montage auf der gegenüberliegenden Seite / Ajuste de disposición inverso / Réglage de la disposition inversée / Regolazione inversa del layout / Dostosowanie odwrotnego układu / Обратная настройка схемы / Възможност за множество ориентации на дънната платка / Inverzní rozložení / Ρύθμιση αντιτροφοφής διάταξης / Fordított kiosztás beállítása / Aanpassingen voor gespiegelde opstelling / Ajustamento inverso de layout / Rotiranje i podešavanje rasporeda konstrukcije / Ters düzen ayarlaması / 倒轉配置調整 / 倒置(180度翻轉)調整 / インバースレイアウト調整 / Pengaturan tata letak terbalik / 역 레이아웃 조정 / تعديل التخطيط العكسي / بیکربندی طرح معکوس

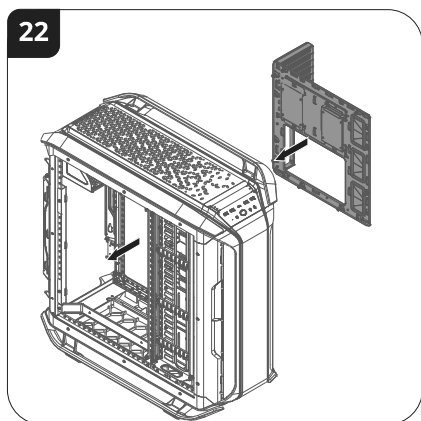
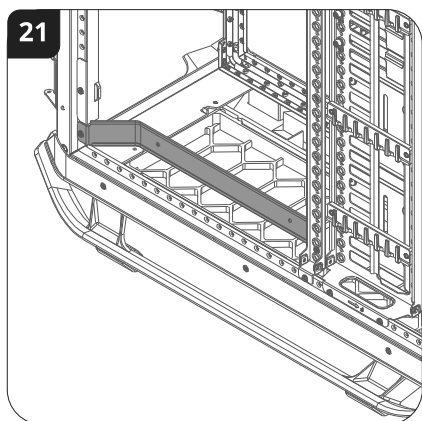
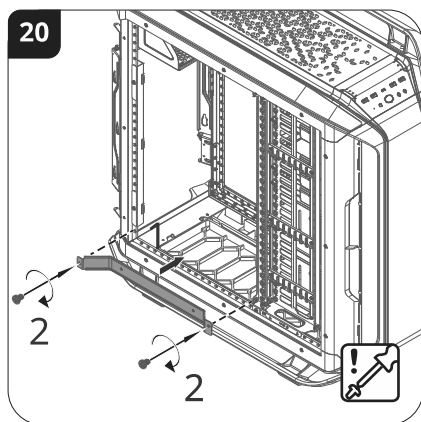
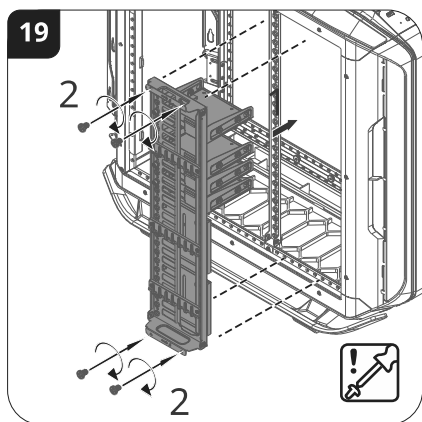
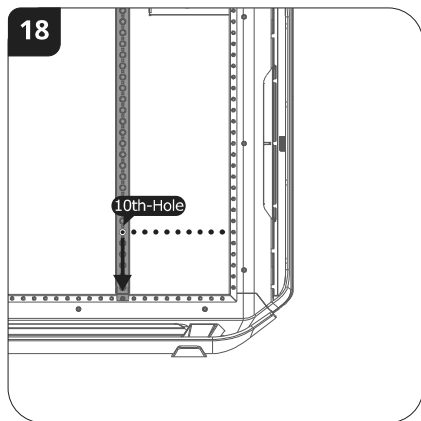
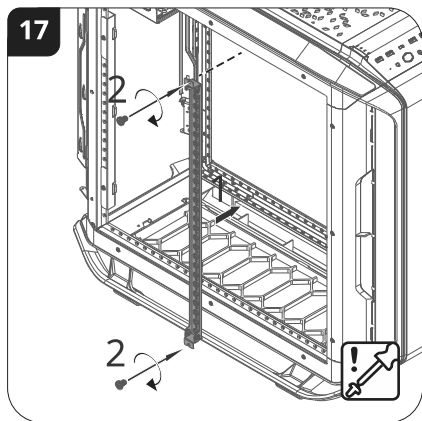







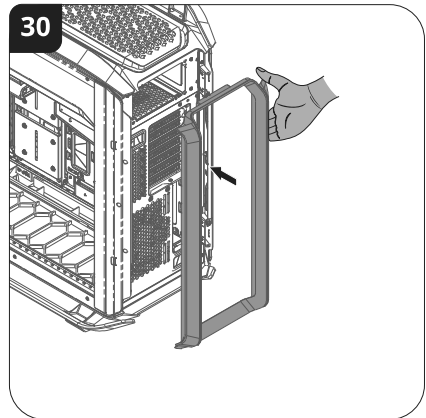
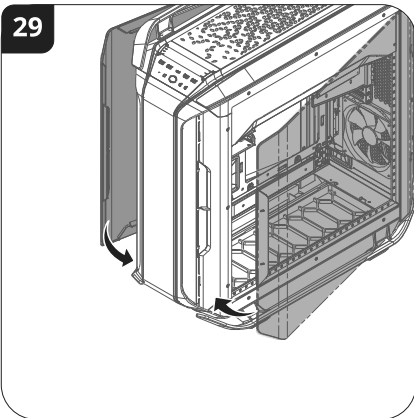
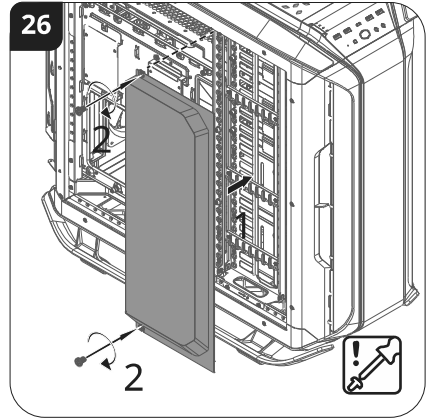
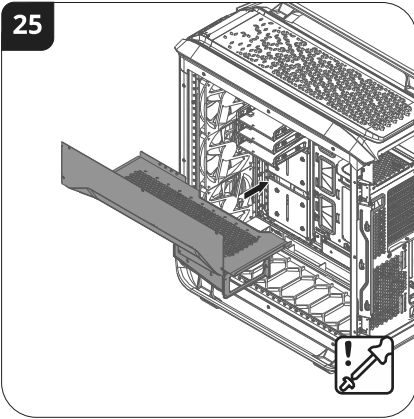
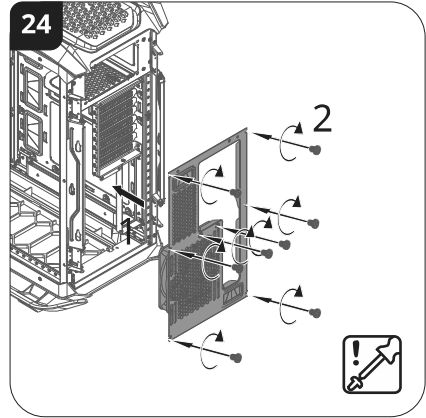
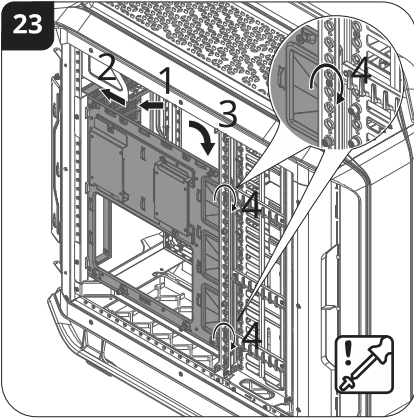

Chimney effect layout adjustment / Anpassung des Layouts: Kamin-Effekt / Ajuste

de la disposición del efecto chimenea / Réglage de la disposition avec effet de cheminée / Regolazione del layout dell'effetto camino / Dostosowanie układu typu efekt kominowy / Регулировка эффекта образования тяги / Възможност за инсталация тип комин / Uspořádání využívající kominový efekt / Ρύθμιση διάταξης φυσικού ελκυσμού / Kémény effektus kiosztás beállítása / Aanpassingen aan de indeling voor Chimney effect / Ajustamento de layout efeito chaminé / Pozicioniranje rasporeda konstrukcije radi efikasnog prenosa toplote "Efekat dimnjaka" / Baca etkisi düzeni ayarı / 煙囪效應配置調整 / 垂直風道(90度旋轉)調整 / 煙突効果レイアウト調整 / Pengaturan tata letak efek cerobong asap / 굴뚝 효과 레이아웃 조정 / تعديل مخطط تأثير المدخنة / بيكريندى طرح «اثر دودکش»

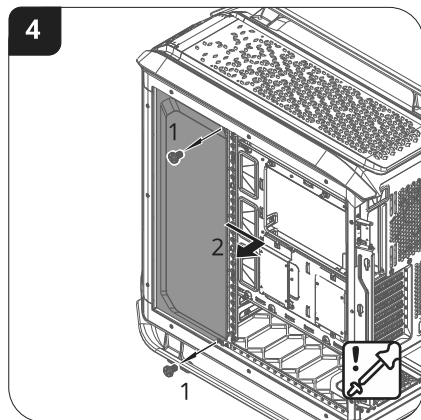
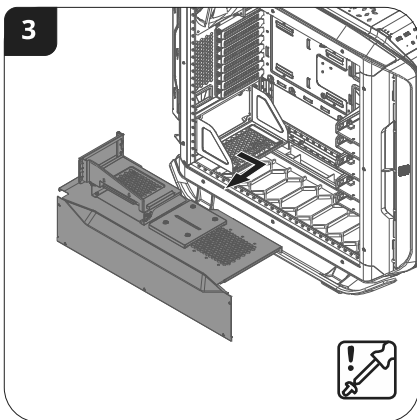
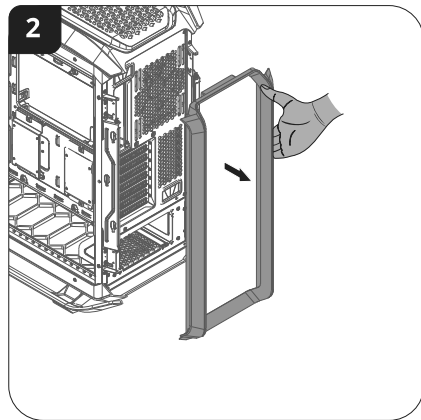
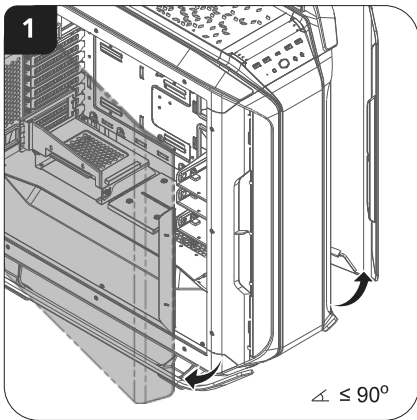

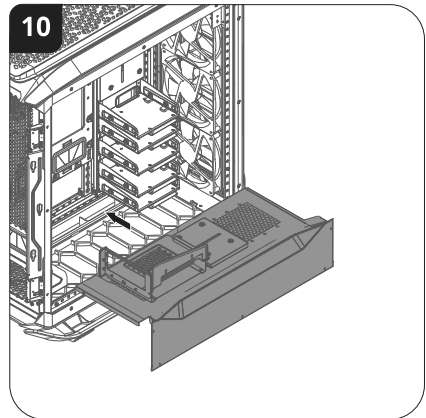
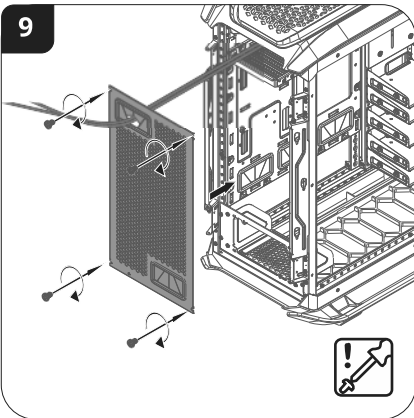
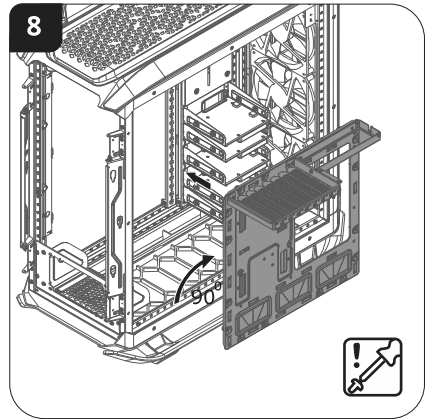
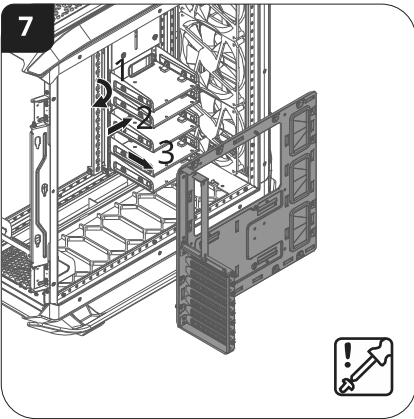
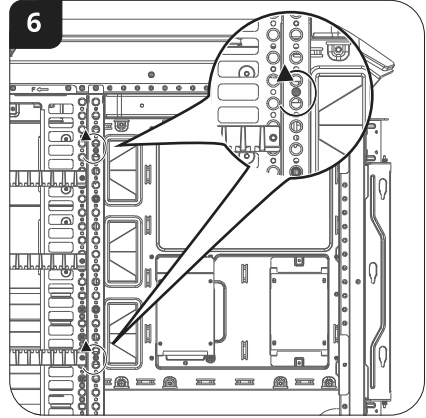
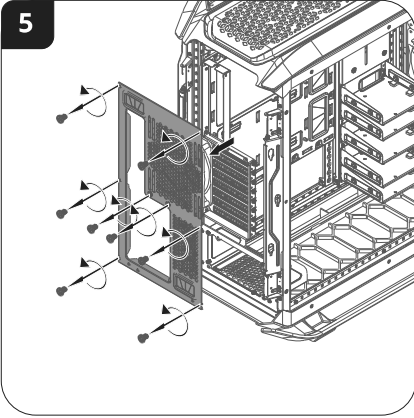

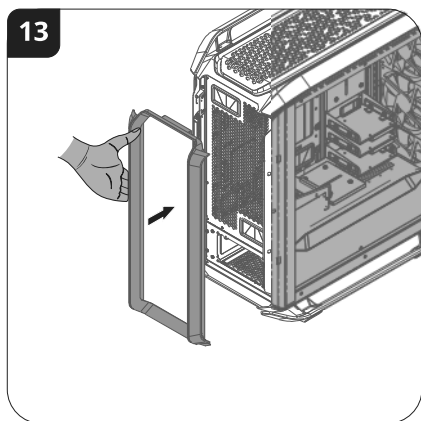
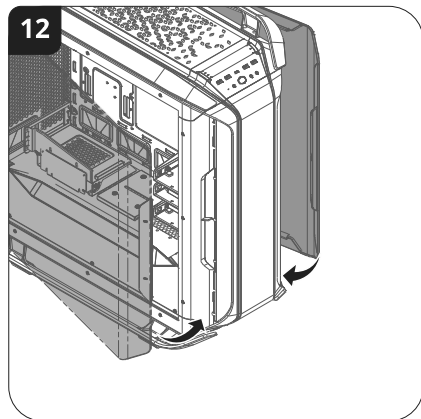
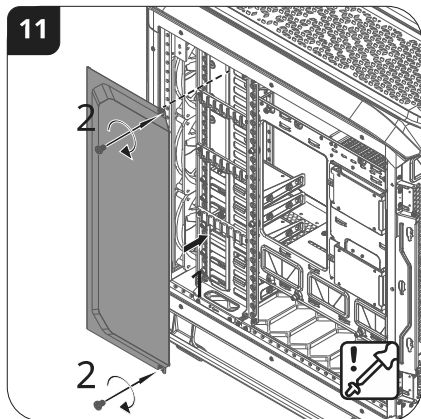



Make It Yours.

Asia Pacific - Cooler Master Technology Inc.
8F., No. 788-1, Zhongzheng Rd., Zhonghe Dist.,
New Taipei City 23586, Taiwan (R.O.C.).
Tel: +886-2-2225-3517

China - Cooler Master China
Room 2062, Floor 6, No. 421, Weiqing Rd.,
Jinshan District, Shanghai City, China
Tel: +86-21-51872177

Europe - Cooler Master Europe B.V.
Lodewijkstraat 1b, 5652AC Eindhoven, The Netherlands
Tel: +31-(0)40-702-0900

North America - Cooler Master NA
2929 E Imperial Hwy., Suite#110, Brea, CA 92821
Tel: +1-888-624-5099

South America
E-mail: Soporte_Latam@coolermaster.com.tw



Product Page

[www.coolermaster.com/case/full-tower/
cosmos-c700m](http://www.coolermaster.com/case/full-tower/cosmos-c700m)



Technical Support

account.coolermaster.com

512001811-GP Ver 2.0: 2018/12 

The color and specification are subject to be changed without further notification.
Please visit our website for updated information: www.coolermaster.com

©2018 Cooler Master Technology Inc. All Rights Reserved. All trademarks are registered to their respective owners.