

Hardware Installation Guide

Product Model: DGS-1250 Series

Gigabit Ethernet Smart Managed Switch

Release 1.00

Information in this document is subject to change without notice. Reproduction in any manner whatsoever, without the written permission of D-Link Corporation, is strictly forbidden.

Trademarks used in this text: D-Link and the D-LINK logo are trademarks of D-Link Corporation; Microsoft and Windows are registered trademarks of Microsoft Corporation.

Other trademarks and trade names may be used in this document to refer to either the entities claiming the marks and names or their products. D-Link Corporation disclaims any proprietary interest in trademarks and trade names other than its own.

© 2019 D-Link Corporation. All rights reserved.

May, 2019 P/N 651GS1250015G

FCC Compliance Statement

This device complies with Part 15 of the FCC Rules. Operation is subject to the following two conditions: (1) This device may not cause harmful interference, and (2) this device must accept any interference received, including interference that may cause undesired operation.

D-Link Corporate
17595 Mt. Hermann Street
Fountain Valley, CA 92708
(800) 326-1688

CE Mark Warning

This equipment is compliant with Class A of CISPR 32. In a residential environment, this equipment may cause radio interference.

VCCI Warning

この装置は、クラス A 機器です。この装置を住宅環境で使用すると電波妨害を引き起こすことがあります。この場合には使用者が適切な対策を講ずるよう要求されることがあります。VCCI-A

BSMI Notice

此為甲類資訊技術設備，於居住環境中使用時，可能會造成射頻擾動，在此種情況下，使用者會被要求採取某些適當的對策。

Safety Compliance

Warning: Class 1 Laser Product: When using a fiber optic media expansion module, never look at the transmit laser while it is powered on. Also, never look directly at the fiber TX port and fiber cable ends when they are powered on.

Avertissement : Produit Laser de Classe 1 : Ne regardez jamais le laser tant qu'il est sous tension. Ne regardez jamais directement le port TX (Transmission) à fibres optiques et les embouts de câbles à fibres optiques tant qu'ils sont sous tension.

Table of Contents

Intended Readers	v
Typographical Conventions	v
Notes and Cautions	v
1. Introduction.....	6
Switch Description	6
Package Contents.....	6
Features	6
Front Panel Components	7
Ports.....	8
Reset Button	9
LED Indicators	9
Rear Panel Components.....	10
Side Panel Components	11
Smart Fans	12
2. Installation.....	13
Installation Guidelines.....	13
Installing the Switch without a Rack	13
Installing the Switch in a Standard 19" Rack	14
Installing Transceivers into the Transceiver Ports.....	15
Power On (AC Power)	15
Power Failure (AC Power).....	16
Installing Power Cord Retainer	16
3. Switch Connections	19
Switch to an End Node	19
Switch to Another Switch	19
Switch to a Server.....	20
4. Switch Management	21
Management Options.....	21
Connecting to the Console Port.....	21
Connecting to the Switch for the First Time.....	22
Creating a User Account.....	23
Configuring the IP Address.....	23
Connecting using SNMP	24
Traps.....	24
Management Information Base (MIB).....	25
5. Web-based Switch Configuration	26
Introduction	26
Logging into the Web UI	26
Web User Interface (Web UI).....	27
Areas of the Web UI	28
Web Pages	28
Appendix A - Technical Specifications.....	30
General	30
Physical and Environmental.....	30
Performance.....	31
LED Indicators	32
Port Functions.....	33
Appendix B - Cables and Connectors.....	35
Ethernet Cable	35

Console Cable (RJ45 to RS-232)	36
Safety/Sécurité	37
Safety Instructions	37
Safety Cautions	37
Consignes de sécurité	38
Précautions de sécurité	38
General Precautions for Rack-Mountable Products	39
Protecting Against Electrostatic Discharge	40
Warranty & Technical Support	41

Intended Readers

The DGS-1250 Series Gigabit Ethernet Smart Managed Switch Hardware Installation Guide contains detailed information about the hardware specifications of the switches in this series. It also contains brief information on how to configure and manage a switch in this series. This manual is intended for advanced level users that are familiar with network management concepts and terminology. For all practical reasons, all the switches in this series will simply be referred to as the Switch throughout this manual.

Typographical Conventions

Convention	Description
Boldface Font	This convention is used to place emphasis on keywords. It also indicates a button, toolbar icon, menu, menu item, system message, or a prompt appearing on the screen. For example, click the Apply button.
Initial capital letter	This convention is used to indicate a window name or keyboard key. For example, press the Enter key.
<i>Blue Courier Font</i>	This convention is used to represent a Command Line Interface (CLI) example.

Notes and Cautions



NOTE: A note indicates important information that helps you make better use of your device.



CAUTION: A caution indicates a potential for property damage, personal injury, or death.

1. Introduction

Switch Description
Package Contents
Features

Switch Description

The DGS-1250 Series is D-Link's next generation Smart Managed Switch. The Switch has a combination of 10/100/1000 Mbps RJ45 ports and 1/10 Gbps SFP/SFP+ ports that may be used to connect various networking devices to the Switch. The SFP/SFP+ ports are used with fiber-optical transceiver cabling in order to uplink various other networking devices for a 1/10 Gbps link that may span great distances. The DGS-1250 Series also implements D-Link's innovative 3rd generation Green Ethernet technology (IEEE 802.3az) by not only saving power over inactive links, but also turning off LEDs on a customized schedule and allowing ports to automatically enter the hibernated state.

The D-Link DGS-1250 Series includes the following switches:

- **DGS-1250-28X** supports twenty-four RJ45 ports (10/100/1000 Mbps) and four SFP/SFP+ ports (1/10 Gbps).
- **DGS-1250-28XMP** supports twenty-four RJ45 PoE ports (10/100/1000 Mbps) and four SFP/SFP+ ports (1/10 Gbps).
- **DGS-1250-52X** supports forty-eight RJ45 ports (10/100/1000 Mbps) and four SFP/SFP+ ports (1/10 Gbps).
- **DGS-1250-52XMP** supports forty-eight RJ45 PoE ports (10/100/1000 Mbps) and four SFP/SFP+ ports (1/10 Gbps).

Package Contents

Open the shipping carton of the Switch and carefully unpack its contents. The carton should contain the following items:

- One DGS-1250 Series switch.
- One Quick Installation Guide.
- One AC power cord.
- One console cable (RJ45 to RS-232).
- One rack mounting kit (two brackets and screws).
- Four rubber feet with adhesive backing.
- One power cord retainer set.
- One CD that includes a digital copy of the CLI Reference Guide, Web UI Reference Guide, and Hardware Installation Guide.

If any item is missing or damaged, please contact your local D-Link reseller for replacement.

Features

The list of features below highlights the significant features of the Switch.

- Supports a 16K MAC address table (for DGS-1250-28X/28XMP); supports a 32K MAC address table (for DGS-1250-52X/52XMP).
- Supports Flow Control (802.3x) in full-duplex compliant.
- Supports Jumbo Frames of up to 12288 bytes.
- Supports Spanning Tree with 802.1D 2004 STP/RSTP and 802.1Q 2005 MSTP.
- Supports Loopback Detection (LBD).
- Supports Link Aggregation (802.3ad and 802.3AX) with a maximum of 8 groups per Switch.

- Supports Port Mirroring.
- Supports Layer 2 Multicast Filtering.
- Supports IGMP Snooping (v1, v2, v3 awareness) with up to 256 snooping groups and 128 static multicast addresses. MLD Snooping (v1, v2 awareness) with up to 256 snooping groups and 128 static multicast addresses. IGMP Snooping and MLD Snooping share 128 static groups and 256 snooping groups.
- Supports Virtual LAN (802.1Q) with up to 4K static VLAN groups and 4K dynamic VLAN groups.
- Supports Port-based VLAN.
- Supports Asymmetric VLAN.
- Supports Auto Voice and Surveillance VLAN.
- Supports IP Interfaces with up to 4 IP interfaces.
- Supports Static Routing.
- Supports Quality of Service (QoS) with Queue Handling and Class of Service (CoS).
- Supports Access Control List (ACL) with Ingress ACL, Time-based ACL, and ACL Statistics.
- Supports Secure Shell (SSHv2) with IPv4/IPv6 access.
- Support Transport Layer Security (TLS) versions 1.0, 1.1, and 1.2.
- Supports Port Security of up to 64 MAC addresses per port.
- Supports Broadcast and Multicast Storm Control.
- Supports Traffic Segmentation.
- Supports D-Link SafeGuard Engine.
- Supports ARP Spoofing Prevention.
- Supports IP-MAC-Port Binding (IMPB). This feature includes DHCP Snooping, IP Source Guard, Dynamic ARP Inspection, DHCPv6 Guard, RA Guard, IPv6 Snooping, IPv6 Source Guard, IPv6 ND Snooping, and IPv6 ND Inspection.
- Supports DoS Attack Prevention.
- Supports Port-based Network Access Control (PNAC) better known as 802.1X. This feature includes Local and RADIUS database, and Port-based Access Control.
- Supports Guest VLAN.
- Supports Link Layer Discovery Protocol (LLDP) with LLDP-MED.
- Supports Accessibility using multiple interfaces like the Command Line Interface (CLI), Web-based Graphical User Interface (Web-based GUI), and more.
- Supports Telnet Server and Client from IPv4 and IPv6.
- Supports Trivial File Transfer Protocol (TFTP) Client.
- Supports Simple Network Management Protocol (SNMP) version 1, 2c, and 3. Also supports SNMP Traps.
- Supports DHCP Client.
- Supports Dynamic Host Configuration Protocol (DHCP) Relay.
- Supports Traps and Logs.
- Support Dual Images and Configurations.
- Supports Simple Network Time Protocol (SNTP).
- Support Power Saving using the Link Status Mode.
- Support Time-based Power-over-Ethernet (PoE).
- Supports IEEE 802.3az compliance.
- Supports D-Link Discovery Protocol (DDP).
- Supports MIBs like MIBII, Bridge MIB, SNMPv2 MIB, RMON MIB, RMONv2 MIB, Ether-like MIB, 802.3 MAU MIB, 802.1p MIB, RADIUS Authentication Client MIB, Ping MIB, L2 Specific MIB, Private MIB, Entity MIB, and ZoneDefense MIB.

Front Panel Components

The front panel of the Switch features a variety of LED indicators, ports, a Reset button and a Mode button (only of PoE supported switches).

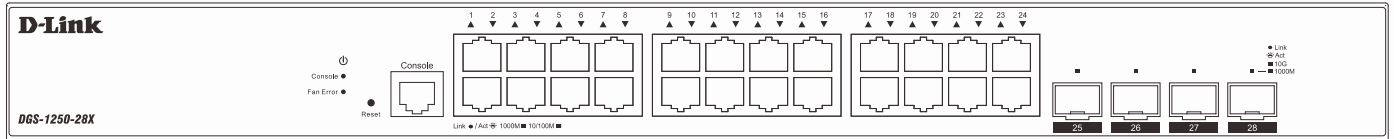

Figure 1-1 Front panel view of the DGS-1250-28X

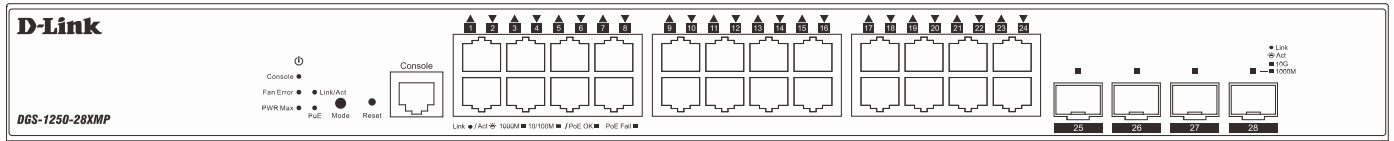

Figure 1-2 Front panel view of the DGS-1250-28XMP

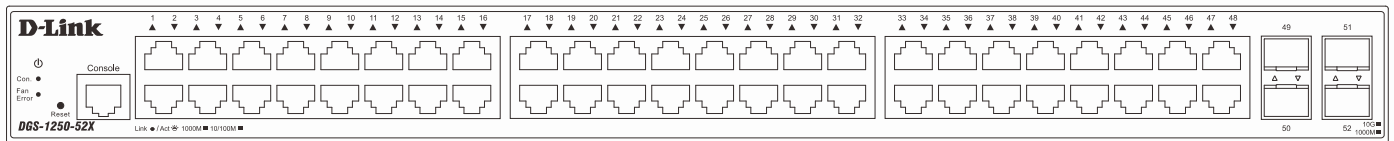

Figure 1-3 Front panel view of the DGS-1250-52X

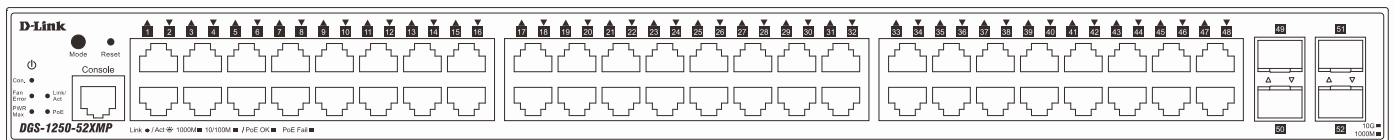

Figure 1-4 Front panel view of the DGS-1250-52XMP

Ports

Ports that can be found on the front panel of this switch are listed in the table below.

Port	Description
Console	The RJ45 console port can be used to connect to the Command Line Interface (CLI) of the Switch for configuration, management, and monitoring. This port uses a special console cable (included in this package) with a DB9 interface to connect the Switch to the serial port (COM) of the PC.
10/100/1000 Mbps RJ45 Ports	The DGS-1250-28X and DGS-1250-52X Switches are equipped with 24 or 48 RJ45 Ethernet ports. These ports can operate at 10 Mbps, 100 Mbps, and 1 Gbps wire-speeds.
10/100/1000 Mbps RJ45 PoE Ports	The DGS-1250-28XMP and DGS-1250-52XMP Switches are equipped with 24 or 48 RJ45 PoE Ethernet ports. These ports can operate at 10 Mbps, 100 Mbps, and 1 Gbps wire-speeds.
10 Gigabit SFP/SFP+ Ports	The Switch is equipped with 4 SFP/SFP+ ports. These ports can operate at 1 Gbps and 10 Gbps wire-speeds and support a wide collection of SFP/SFP+ transceivers.

For a complete list of SFP/SFP+ transceivers that are compatible with this switch, refer to the **SFP+/SFP Ports** section in **Appendix A - Technical Specifications**.

Reset Button

On the front panel of the Switch is a **Reset** button. The Switch will reboot or reset to factory default settings depending on how long this button is pressed.

- Press and hold the **Reset** button for less than 5 seconds (release before 5 seconds) to reboot the Switch. All unsaved configurations will be lost.
- Press and hold the **Reset** button for more than 5 seconds (release between 6 and 10 seconds) to reset the software configuration of the Switch to the factory default settings. All the port LEDs will light up (solid amber) for 2 seconds to indicate the start of the factory reset procedure.

LED Indicators

Located on the front panel of this switch are LED indicators: Power, Console, Fan Error, and Link/Act indicators for all the ports. The **DGS-1250-28XMP** and **DGS-1250-52XMP** switches are equipped with Power Max., PoE indicators for all the ports, and Link/Act and PoE indicators for mode selection.

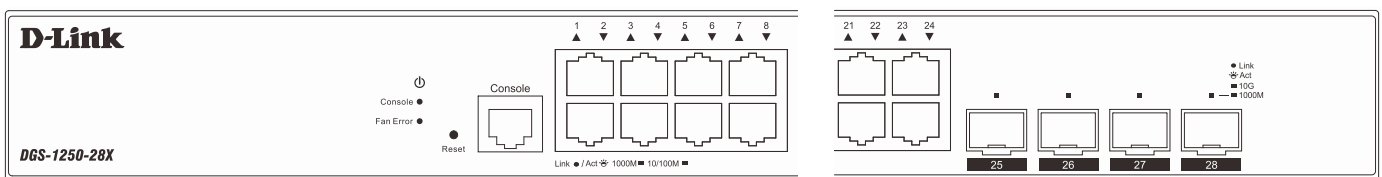

Figure 1-5 LED indicators for the DGS-1250-28X

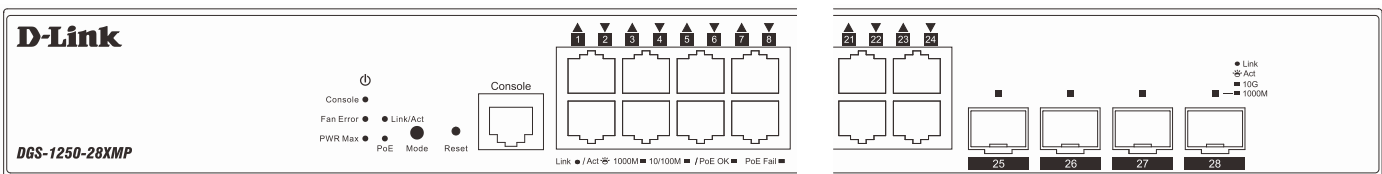

Figure 1-6 LED indicators for the DGS-1250-28XMP

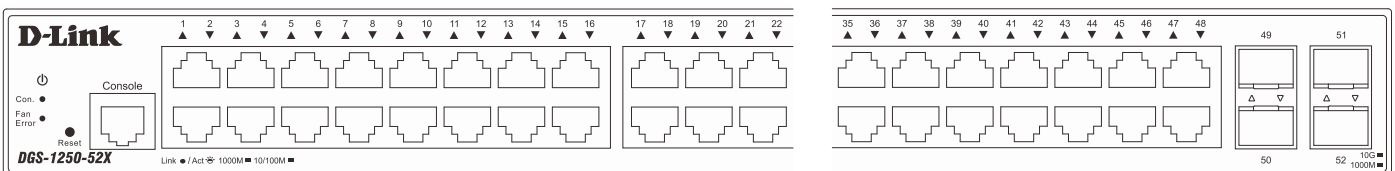

Figure 1-7 LED indicators for the DGS-1250-52X

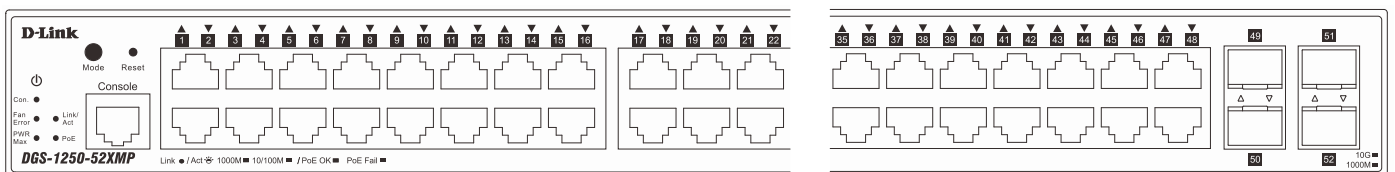

Figure 1-8 LED indicators for the DGS-1250-52XMP

LED	Description
Power	This LED will light solid green after the Switch has been powered on successfully. This LED will be off when the Switch is no longer receiving power (i.e. powered off).
Console	This LED will light solid green when the console port is active. This LED will be off when the console port is not active.

LED	Description
Fan Error	This LED will light solid red when the fan fails. This LED will be off when the fan is operating normally.
PWR Max. (DGS-1250-28XMP and DGS-1250-52XMP Only)	This LED will light solid red when the power supplied to attached PDs exceeds the maximum PoE budget. This LED will blink red when the power supplied to attached PDs approaches the maximum PoE budget (within 7 Watts) and enters the Guardband mode. This LED will be off when no power is supplied to attached PDs or when no PDs are attached.
Link/Act LEDs	The Switch has LED indicators for Link and Activity. RJ45 Ports: This LED will light solid green when there is a connection (or link) to a 1000 Mbps Ethernet device or solid amber when there is a connection (or link) to a 10/100 Mbps Ethernet device on any of the RJ45 ports. The LED will blink green when a 1000 Mbps port is active or blink amber when a 10/100 Mbps port is active. The LED will be off when there is no link or activity. SFP/SFP+ Ports: This LED will light solid green when there is a connection (or link) to a 10 Gbps Ethernet device or solid amber when there is a connection (or link) to a 1 Gbps Ethernet device at any at any of the SFP/SFP+ ports. The LED will blink green when a 10 Gbps port is active or blink amber when a 1 Gbps port is active. The LED will be off when there is no link or activity.
PoE (DGS-1250-28XMP and DGS-1250-52XMP Only)	This LED will light solid green when the corresponding ports are feeding power to the PoE devices plugged in. This LED will light solid amber when the port is in an error condition state. This LED will be off when the ports are not supplying power to the devices plugged into the ports.

Please refer to the “LED Indicators” section in the **Appendix A - Technical Specifications** for more LED information.

Rear Panel Components

The rear panel of this switch features a security lock, a GND, an AC power connector, and a power cord retainer hole.

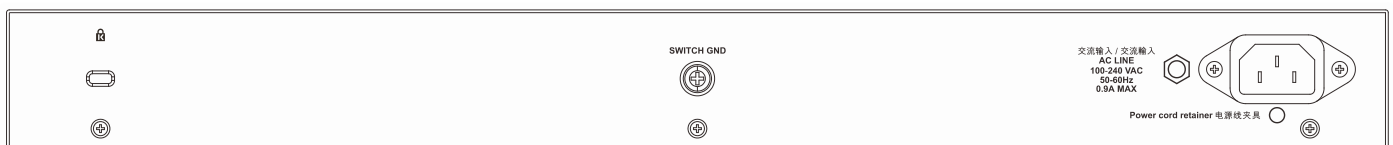

Figure 1-9 Rear panel view of the DGS-1250-28X

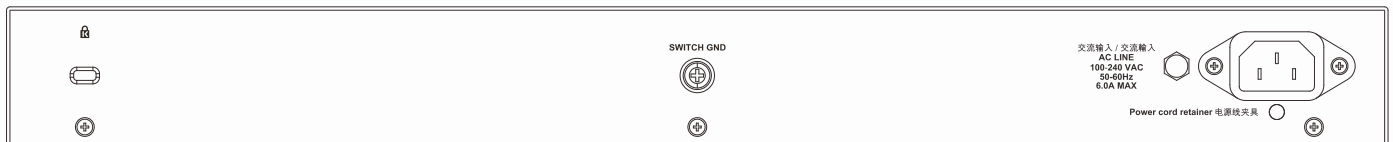

Figure 1-10 Rear panel view of the DGS-1250-28XMP

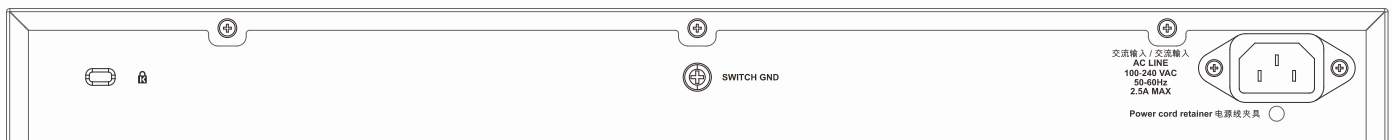

Figure 1-11 Rear panel view of the DGS-1250-52X

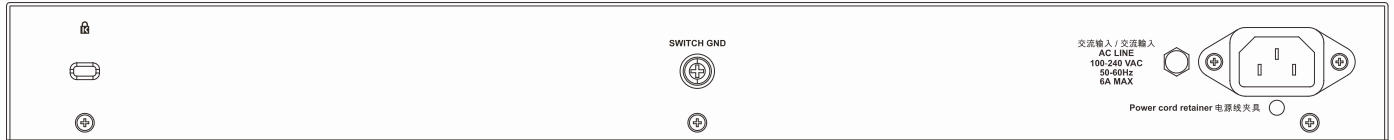

Figure 1-12 Rear panel view of the DGS-1250-52XMP

Components that can be found on the rear panel of this switch are listed in the table below.

Component	Description
Security Lock	Provide a Kensington-compatible security lock to be able to connect to a secure immovable device. Insert the lock into the notch and turn the key to secure the lock. The lock-and-cable apparatus should be purchased separately.
Switch GND	Use an electrical grounding wire and connect one end of the wire to the Switch GND and the other end of the wire to an electrical grounding point most commonly found on the Switch mounting rack itself.
AC Power Connector	The AC power cord with a three-pronged AC power connector can be plugged into this receptacle to supply the Switch with 100-240 VAC power at 50-60 Hz.
Power Cord Retainer Hole	The power cord retainer hole is used to insert the power cord retainer to secure the AC power cord.

Side Panel Components

The side panels of this switch contain heat vents, fans, and rack-mounting screw holes. The heat vents are used to dissipate internal heat and facilitate internal air circulation. Do not block these openings. Leave at least 4 inches of space at the sides of the Switch for proper ventilation. Without proper heat dissipation and air circulation, system components might overheat which could lead to system failure or even severely damaged components.

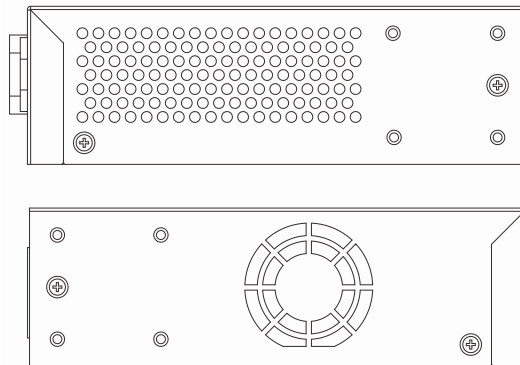

Figure 1-13 Side panels of the DGS-1250-28X

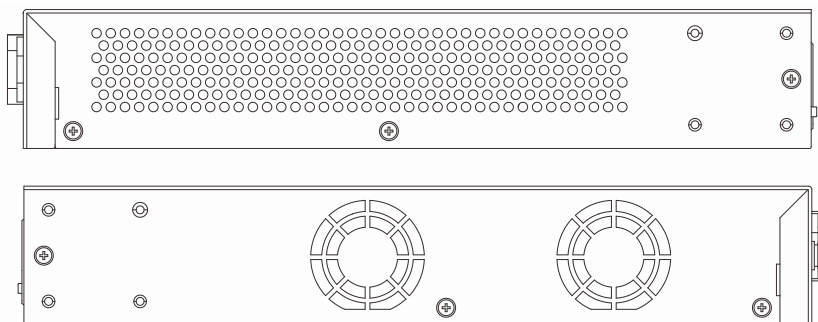

Figure 1-14 Side panels of the DGS-1250-28XMP

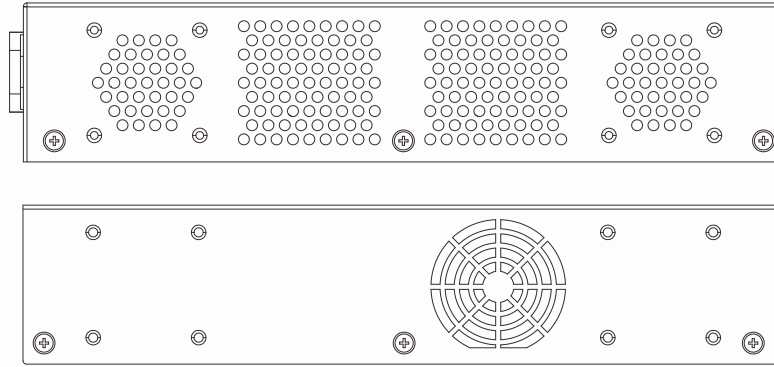

Figure 1-15 Side panels of the DGS-1250-52X

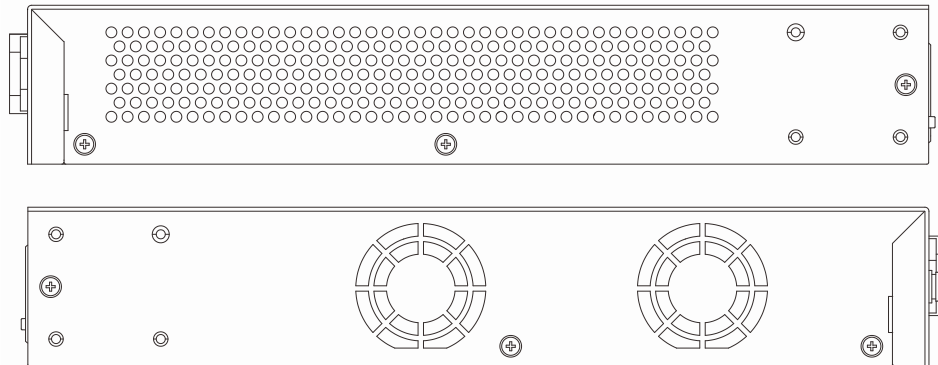

Figure 1-16 Side panels of the DGS-1250-52XMP

Smart Fans

The DGS-1250 Series Switches includes **smart fans** that will automatically change their speed depending on the internal temperature detected by the sensors built-in the Switch's hardware.

The following will explain at what temperature the speed of the fan(s) will change:

- **DGS-1250-28X:** The fan speed will change from:
 - Low Speed to High Speed at 69°C.
 - High Speed to Low Speed at 57°C.
- **DGS-1250-28XMP:** The fan speed will change from:
 - Low Speed to High Speed at 46°C.
 - High Speed to Low Speed at 36°C.
- **DGS-1250-52X:** The fan speed will change from:
 - Low Speed to High Speed at 65°C.
 - High Speed to Low Speed at 60°C.
- **DGS-1250-52XMP:** The fan speed will change from:
 - Low Speed to High Speed at 51°C.
 - High Speed to Low Speed at 46°C.

2. Installation

Installation Guidelines

Installing the Switch without a Rack

Installing the Switch in a Standard 19" Rack

Installing Transceivers into the Transceiver Ports

Power On (AC Power)

Installation Guidelines

This section will discuss the hardware installation guidelines that the user must follow in order to properly and safely install this switch into the appropriate environment.

- Visually inspect the power cord and see that it is fully secured to both the power connector, on the Switch, and the electrical outlet that supplies power.
- Install the Switch in a fairly cool and dry place within the acceptable operating temperature and humidity ranges. For more information about the acceptable operating temperature and humidity ranges, refer to the Physical and Environmental section.
- Install the Switch in a site free from strong electromagnetic field generators such as motors, vibration, dust, and direct exposure to sunlight.

Installing the Switch without a Rack

This section is used to guide the user through installing the Switch in an area other than a switch rack. Attach the included rubber feet to the bottom of the Switch. Take note that there should be marked blocks on the bottom of the Switch to indicate where to attach the rubber feet. These markings are usually found in each corner on the bottom of the device. The rubber feet cushion the Switch, protecting the casing from scratches and preventing it from scratching other surfaces.

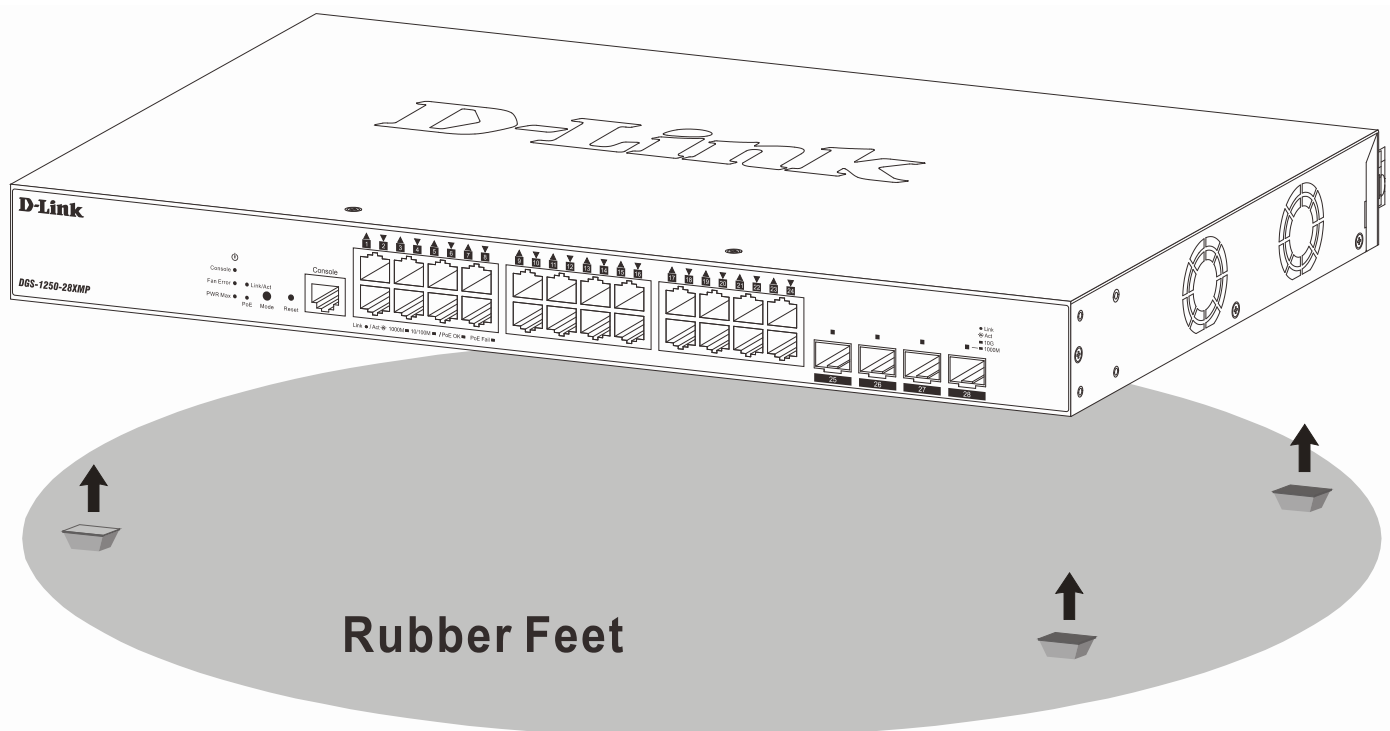

Figure 2-1 Attaching rubber feet to the Switch

Install the Switch on a sturdy, level surface that can support the weight of the Switch (see the **Weight** section in **Appendix A - Technical Specifications**). Do not place any heavy objects on the Switch. The power outlet should be

within 1.82 meters (6 feet) of the Switch. Make sure that there is proper heat dissipation from and adequate ventilation around the Switch. Leave at least 10 cm (4 inches) of space at the front, sides, and rear of the Switch for ventilation.

Installing the Switch in a Standard 19" Rack

This section is used to guide the user through installing the Switch into a switch rack. The Switch can be mounted in a standard 19"(1U) rack using the provided mounting brackets.

1. Fasten the mounting brackets to the sides of the Switch using the screws provided.

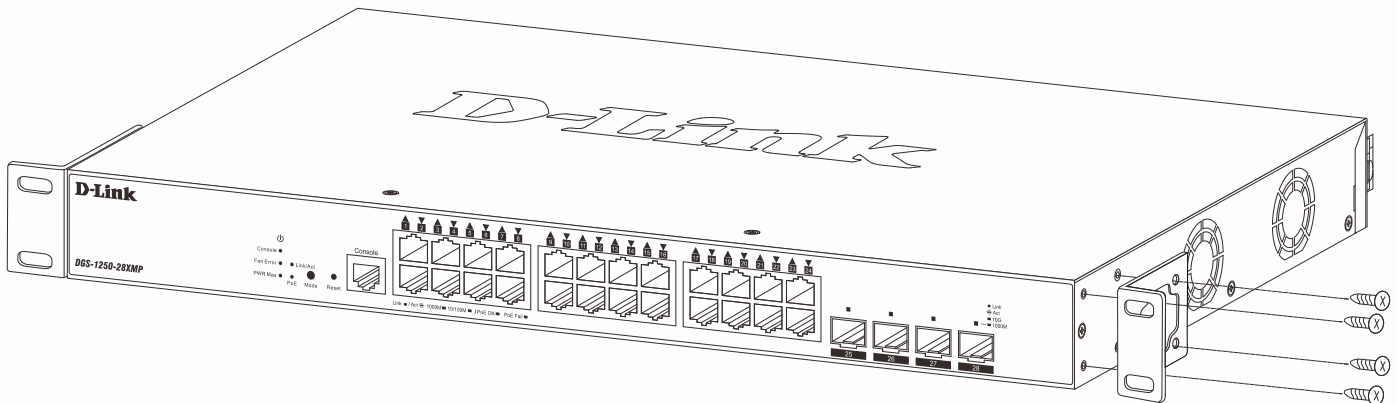

Figure 2-2 Attaching rack-mount brackets to the Switch

2. Fasten the mounting brackets in any available open space in the rack using the screws provided.

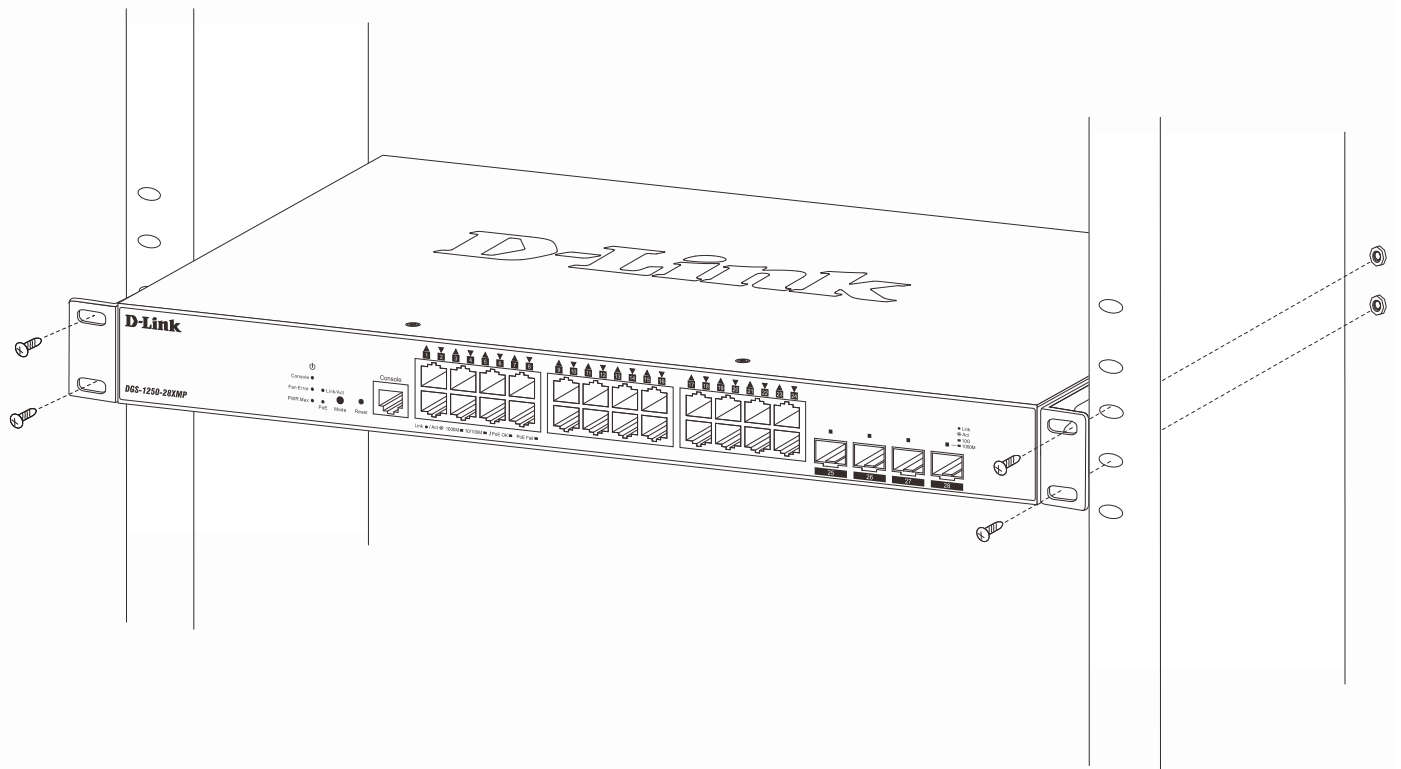

Figure 2-3 Installing the Switch in a Rack

Make sure that there is adequate space around the Switch to allow for proper air flow, ventilation, and cooling.

Installing Transceivers into the Transceiver Ports

The Switch is equipped with Small Form-factor Pluggable (SFP) and Enhanced Small Form-factor Pluggable (SFP+) ports that can be used to connect various other networking devices to this switch that do not support the standard RJ45 wiring connection. These ports are generally used to connect this switch to optical fiber connections and can be used to connect devices to the Switch over great distances. The maximum distance that the RJ45 wiring connection can reach is 100 meters. Fiber optic connections can span several kilometers.

The figure below illustrates how to properly insert SFP/SFP+ transceivers into the Switch's SFP/SFP+ ports.

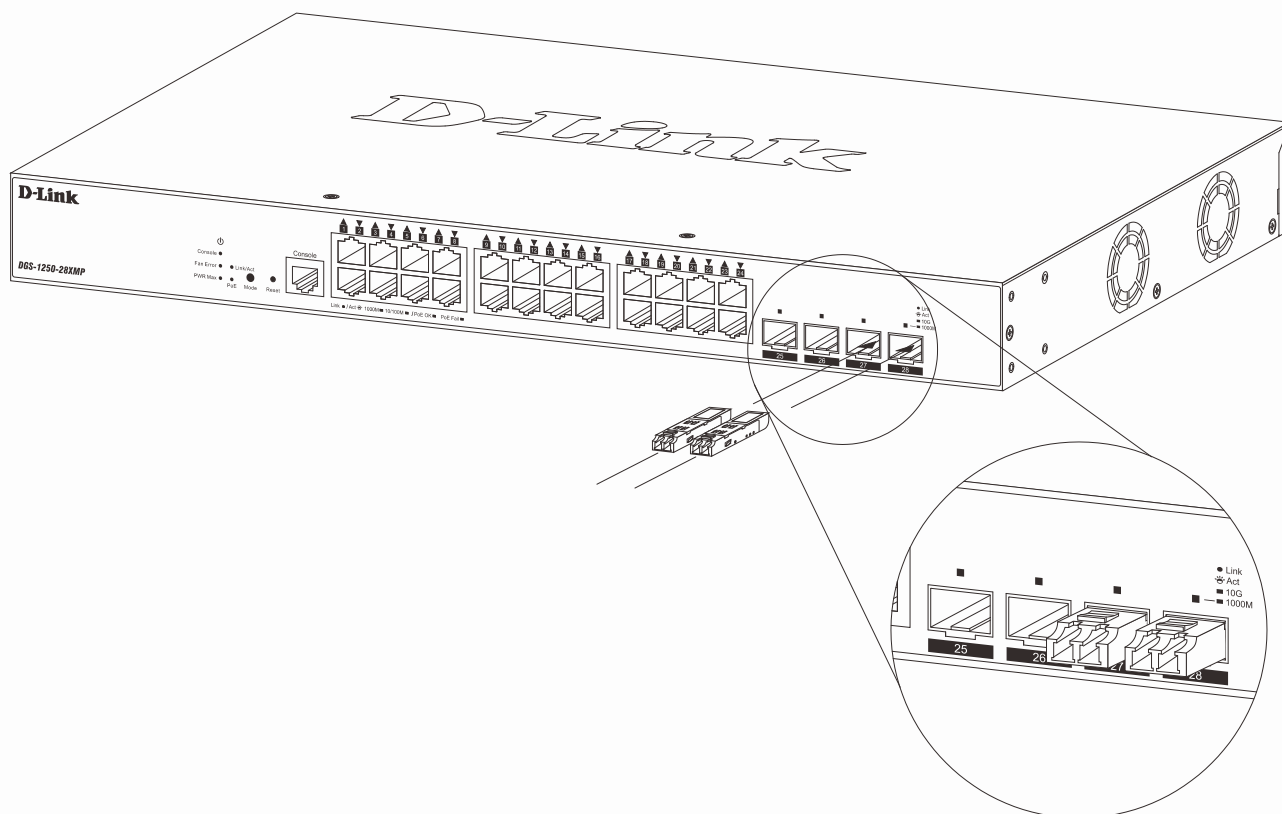

Figure 2-4 Inserting transceivers into the transceiver ports

The SFP/SFP+ ports also support other transceiver form factors like **SFP** and **SFP+** transceivers. A complete list of SFP/SFP+ transceivers, compatible with this switch, can be found in the **SFP+/SFP Ports** section in **Appendix A - Technical Specifications** at the end of this document.

NOTE: Only use pluggable optical modules and Direct-Attach Cables (DAC) that meet the following regulatory requirements:



- Class 1 Laser Product
- UL and/or CSA registered component for North America
- FCC 21 CFR Chapter 1, Sub-chapter J in accordance with FDA & CDRH requirements
- IEC/EN 60825-1/-2: 2007 2nd edition or later, European Standard

Power On (AC Power)

Plug one end of the AC power cord into the power socket of the Switch and the other end into the local power source outlet. After the system is powered on, the LED will blink green to indicate that the system is booting up.

Power Failure (AC Power)

In the event of a power failure, just as a precaution, unplug the power cord from the Switch. After the power returns, plug the power cord back into the power socket of the Switch.

Installing Power Cord Retainer

To prevent accidental removal of the AC power cord, it is recommended to install the power cord retainer together with the power cord.

1. With the rough side facing down, insert the tie wrap into the hole below the power socket.

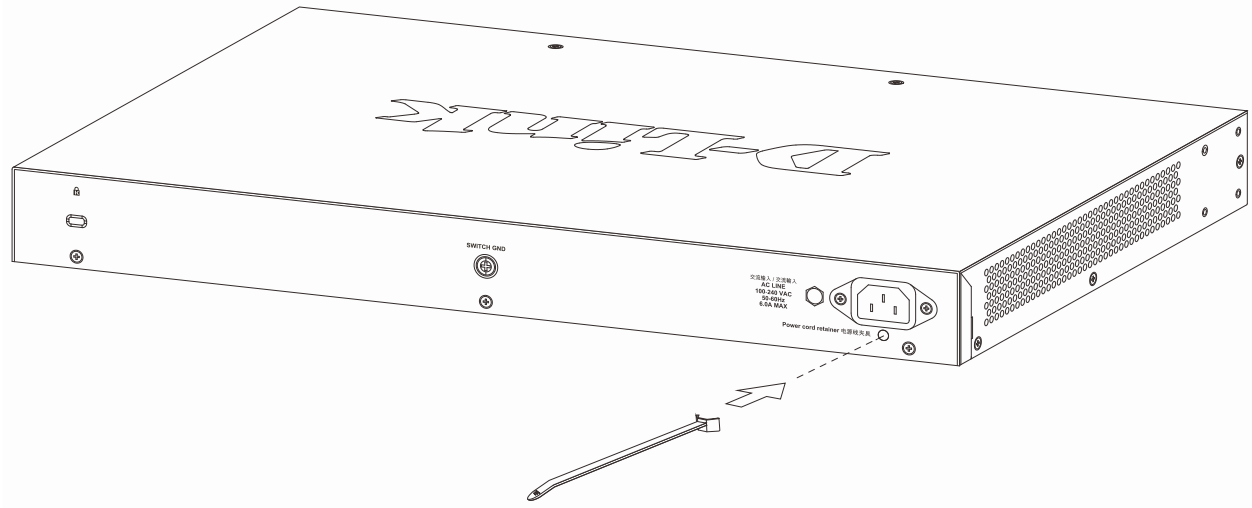

Figure 2-5 Insert Tie Wrap into the Switch

2. Plug the AC power cord into the power socket of the Switch.

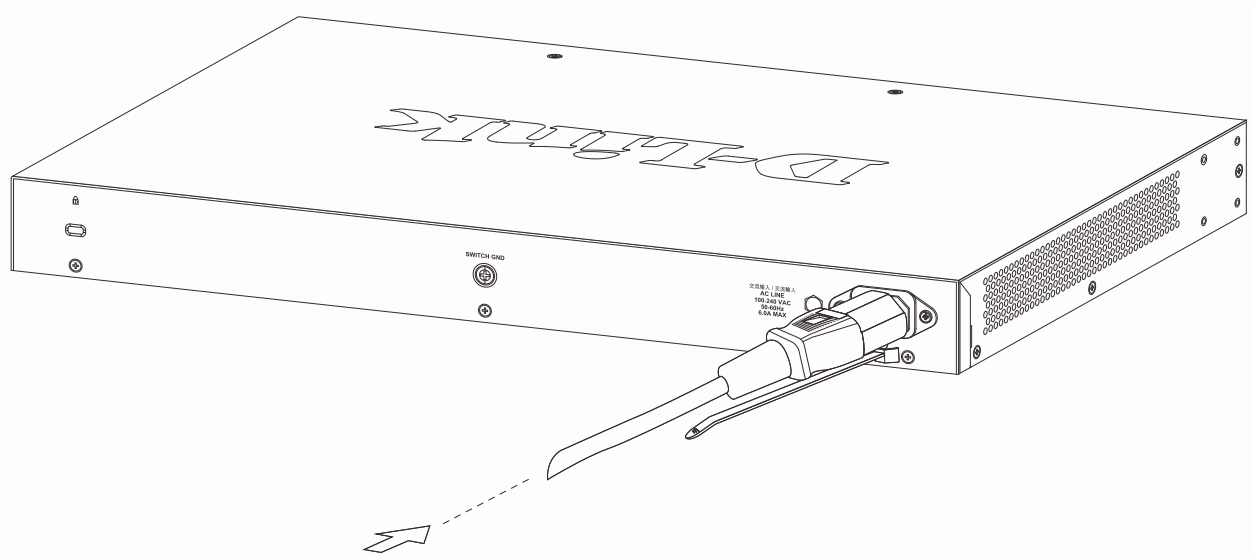

Figure 2-6 Connect the power cord to the Switch

- Slide the retainer through the tie wrap until the end of the cord.

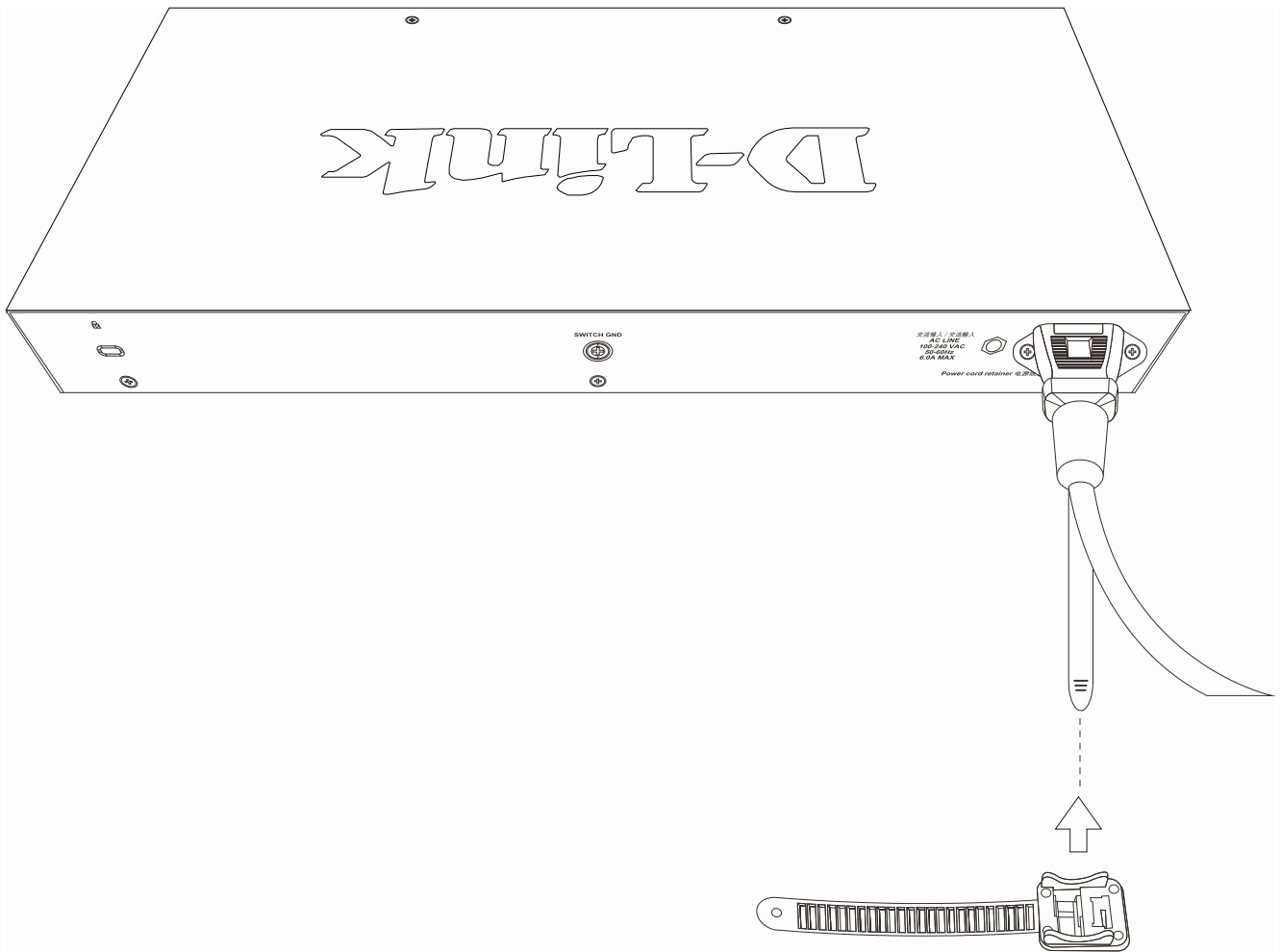

Figure 2-7 Slide the Retainer through the Tie Wrap

- Circle the tie of the retainer around the power cord and into the locker of the retainer.

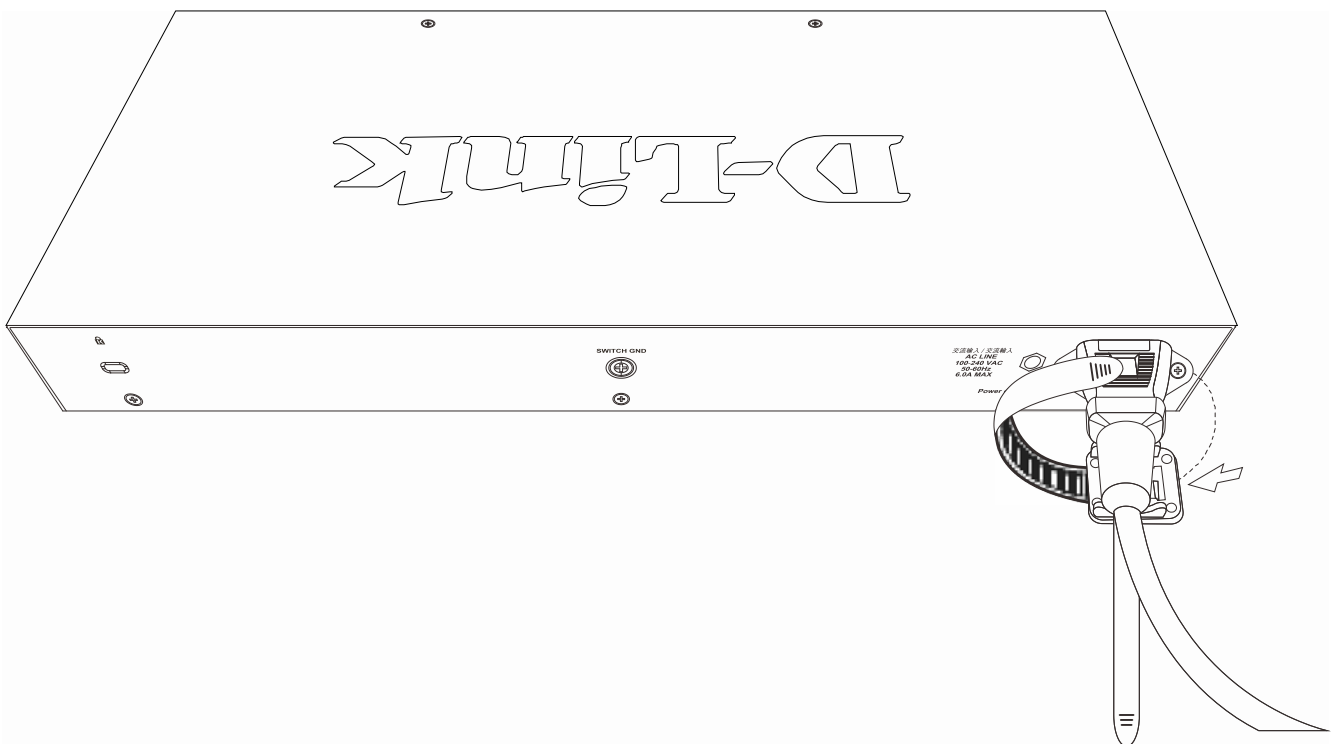

Figure 2-8 Circle around the power cord

5. Fasten the tie of the retainer until the power cord is secured.

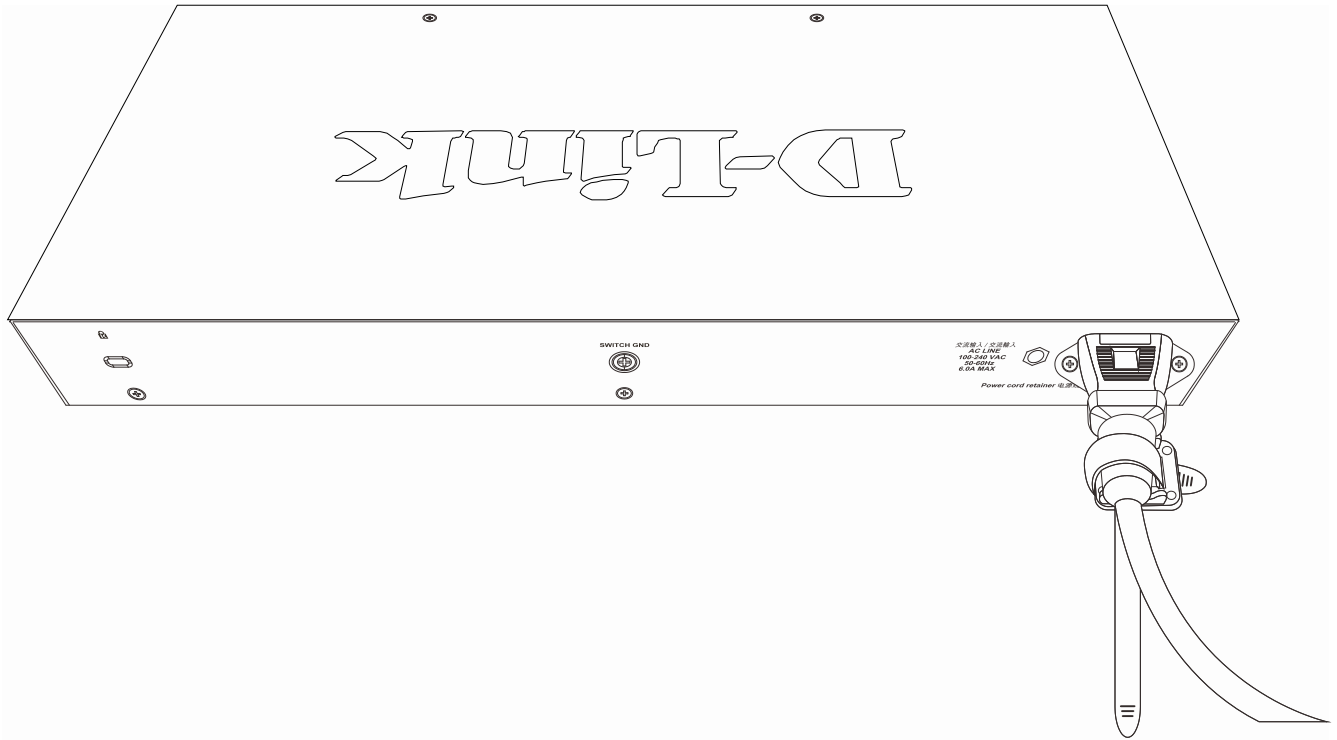

Figure 2-9 Secure the power cord

3. Switch Connections

Switch to an End Node
Switch to Another Switch
Switch to a Server

Switch to an End Node

An end node is a generic name for edge networking devices that will be connected to this switch. Typical examples of end nodes are Personal Computers (PCs), Notebooks, Access Points, Print Servers, VoIP Phones and more. Each end node should be fitted with a 100/1000/10000 Mbps RJ45 networking port. Normally, end nodes will connect to this switch by using a standard twisted-pair UTP/STP network cable. When a successful connection is established, the corresponding port light will illuminate and blink to indicate that network activity is taking place on that port.

The diagram below displays a typical end node connected to the Switch.

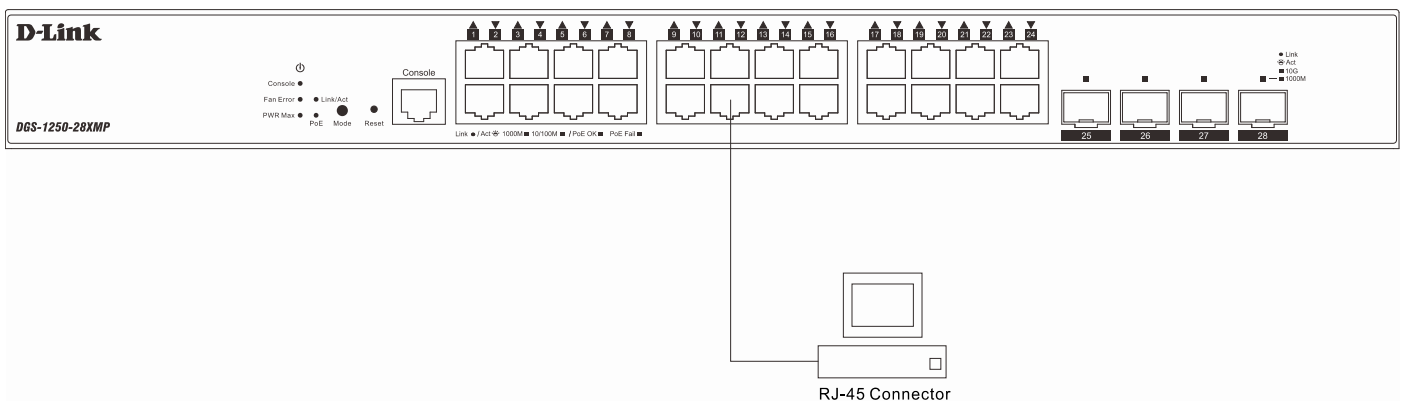

Figure 3-1 Connecting the Switch to an End Node

Switch to Another Switch

The Switch can be used to connect to any other switch or hub in the network. This network topology is used when the Switch does not have enough ports to cater for all the end nodes in the network.

There is a great deal of flexibility on how connections are made using the appropriate cabling.

- Connect a 10BASE-T switch port to the Switch using a twisted-pair Category 3, 4, or 5 UTP/STP cable.
- Connect a 100BASE-TX switch port to the Switch via a twisted-pair Category 5 UTP/STP cable.
- Connect a 1000BASE-T switch port to the Switch via a twisted pair Category 5e UTP/STP cable.
- Connect a switch supporting an optical fiber uplink to the Switch's SFP/SFP+ ports via fiber optical cabling.

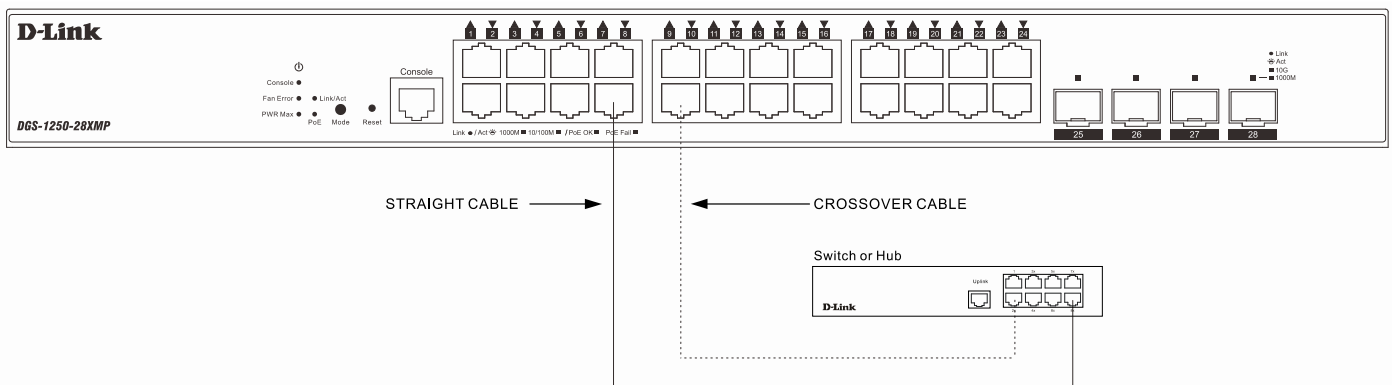

Figure 3-2 Connecting the Switch to another switch/hub

Switch to a Server

The Switch is ideal for connecting to a network backbone, server, or server farm. The RJ45 ports operate at a speed of 10/100/1000 Mbps. The SFP ports operate at a speed of 100/1000 Mbps. The SFP/SFP+ ports operate at a speed of 1/10 Gbps.

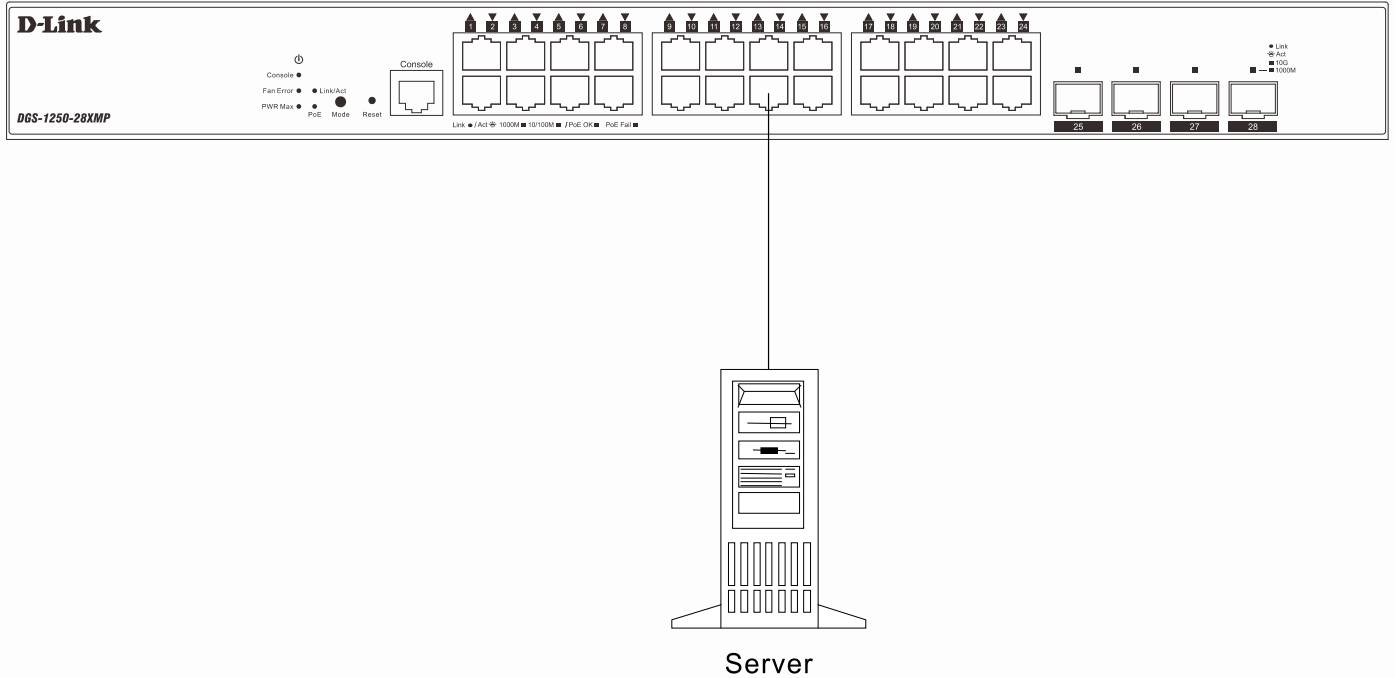

Figure 3-3 Connecting the Switch to a server

4. Switch Management

Management Options

Connecting to the Console Port

Connecting using SNMP

Management Options

This switch provides multiple access platforms that can be used to configure, manage, and monitor networking features available on this switch. Currently there are three management platforms available which are described below.

Command Line Interface (CLI)

This switch can be managed, out-of-band, by using the console port on the front panel of the Switch. Alternatively, the Switch can also be managed, in-band, by using a Telnet connection to any of the LAN ports on the Switch. The command line interface provides the access to some of switch management features.

For more detailed information about the CLI, refer to the *DGS-1250 Series CLI Reference Guide*.

SNMP-based Management

The Switch can be managed with an SNMP-compatible console program. The Switch supports SNMP v1, SNMPv2c and SNMPv3. The SNMP agent decodes the incoming SNMP messages and responds to requests with MIB objects stored in the database. The SNMP agent updates the MIB objects to generate statistics and counters.

Web User Interface (Web UI)

The Web UI can be accessed from any computer running web browsing software from its LAN port when it is connected to any of the RJ45 or SFP/SFP+ ports. The Web UI on the Switch can also be accessed using an HTTPS (SSL) connection.

This management interface is a more graphical representation of the features that can be viewed and configured on this Switch. Most of the features available through the CLI can be accessed through the Web UI. Web browsers like Microsoft's Internet Explorer, Mozilla Firefox, Google Chrome, or Safari can be used.

For more detailed information about the Web UI, refer to the *DGS-1250 Series Web UI Reference Guide*.

Connecting to the Console Port

The front panel of the Switch provides an RJ45 console port to connect a remote system for monitoring and configuring the Switch.

To use the console port, the following equipment is needed:

- A terminal or a computer with both an RS-232 serial port and terminal emulation software.
- A console cable with a male DB9 connector on one end and an RJ45 connection on the other. This cable should be included with the Switch. It establishes the physical connection to the console port.

To connect the RJ45 console port on the Switch to the computer:

- Connect the male DB9 connector on the console cable (shipped with the Switch) to the RS-232 serial port on the computer running terminal emulation software then insert the RJ45 connector into the RJ45 console port on the front of the Switch.

To configure the terminal emulation software as follows:

- Select the appropriate serial port (COM1 or COM2).
- Set the data rate to 115200 baud.
- Set the data format to 8 data bits, 1 stop bit, and no parity.
- Set flow control to none.

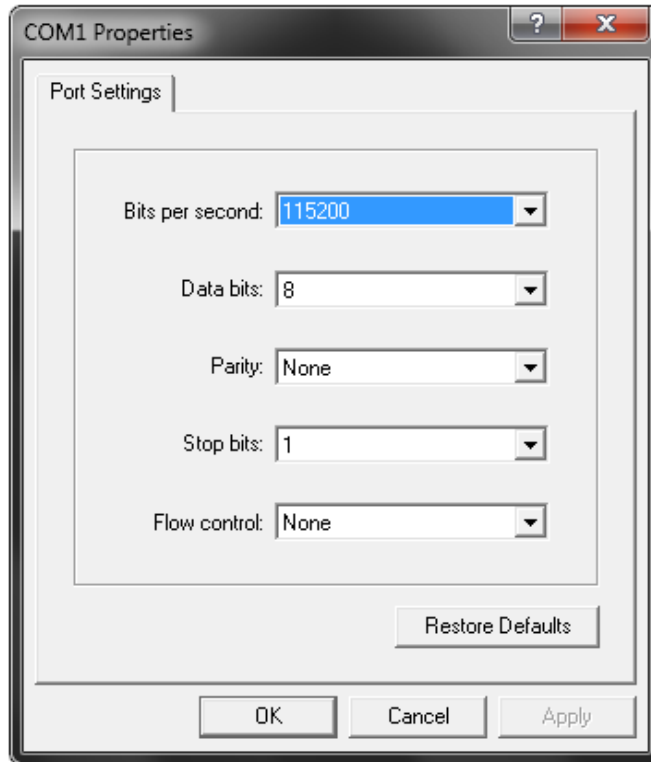

Figure 4-1 COM Port Configuration

To be able to view the boot procedure, the Switch needs to be rebooted. The simplest way, at this stage, to reboot the Switch is to unplug and re-insert the power cable from and into the power receptacle on the back of the Switch. After correctly configuring the terminal settings and re-inserting the power cable, the boot procedure will appear in the terminal.

Loader Procedure

```
-----
Please Wait, Loading 1.00.038 Runtime Image ..... 100 %
UART init ..... 100 %
Starting runtime image
Device Discovery ..... 100 %
Configuration init ..... 100 %
```

After the boot sequence has been completed, the console login screen will be displayed.

Connecting to the Switch for the First Time

The Switch supports user-based security that can prevent unauthorized users from accessing the Switch or changing its configuration. This section will explain how to log into the Switch's Command Line Interface via the out-of-band console connection.

Both the default **Username** and **Password** is *admin*. Enter the username and password when prompt to do so and press enter after each entry. The CLI prompt will immediately be available, as shown below.

```
DGS-1250-28XMP Gigabit Ethernet Smart Managed Switch
```

```
Command Line Interface
```

```
Firmware: Build 1.00.038
```

```
Copyright(C) 2019 D-Link Corporation. All rights reserved.
```

```
User Access Verification
```

```
Username:admin
```

```
Password:*****
```



NOTE: For security reasons, it is highly recommended to configure a personal username and password for this Switch.

Creating a User Account

One of the first and most important tasks will be to create user accounts. Logging in using a predefined administrator-level username will give the user privileged access to the Switch's management software. Also this will prevent unauthorized access to the Switch and record the passwords for future reference.

An example to create an administrator-level account for the Switch called 'NewUser':

```
Switch#configure terminal
Switch(config)#username NewUser password 12345
Switch(config)#end
Switch#
```

In the example above:

1. At the CLI command prompt, enter the **configure terminal** command to enter the **Global Configuration Mode**. Press ENTER.
2. Enter the **username NewUser password 12345** command. Press ENTER. This will create a user account with the username of NewUser and a password of 12345.
3. Enter the **end** command to exit back to the **EXEC Mode**.



NOTE: Passwords are case sensitive. Usernames can be up to 32 characters in length. Passwords can be up to 32 plain-text characters in length.

Configuring the IP Address

Each switch must be assigned its own in-band IP Address, which is used for communication with an SNMP network manager or other TCP/IP applications. The Switch's default IP address is 10.90.90.90 with a subnet mask of 255.0.0.0. You can change the IP address of the Switch to meet the specification of your networking address scheme.

The IP address of the Switch must be configured before it can be managed, by the user, via the Web UI.

An example to change the IP address of the Switch to '10.50.50.50', using a subnet mask of '255.0.0.0':

```
Switch#configure terminal
Switch(config)#interface vlan 1
Switch(config-if)#ip address 10.50.50.50 255.0.0.0
Switch(config-if)#
```

In the above example,

1. We entered the **Global Configuration Mode** by entering the **configure terminal** command.
2. Then we entered the **VLAN Configuration Mode** of the default VLAN, which is VLAN 1, by entering the **interface vlan 1** command.
3. Then we changed the IP address of the Switch to 10.50.50.50 and the subnet mask to 255.0.0.0 by entering the **ip address 10.50.50.50 255.0.0.0** command.

The Switch can now be accessed and configured through Telnet or the Web UI. The Switch's IP address can also automatically be obtained by using the DHCP protocol.

Connecting using SNMP

The Simple Network Management Protocol (SNMP) is an OSI Layer 7 (Application Layer) protocol designed specifically for managing and monitoring network devices. SNMP enables network management stations to read and modify the settings of gateways, routers, switches, and other network devices. Use SNMP to configure system features for proper operation, monitor performance, and detect potential problems in the Switch, switch group, or network.

Managed devices that support SNMP include software (referred to as an agent), which runs locally on the device. A defined set of variables (managed objects) is maintained by the SNMP agent and used to manage the device. These objects are defined in a Management Information Base (MIB), which provides a standard presentation of the information controlled by the on-board SNMP agent. SNMP defines both the format of the MIB specifications and the protocol used to access this information over the network.

The Switch supports SNMPv1, SNMPv2c, and SNMPv3. The administrator may specify which SNMP version to use to monitor and control the Switch. The three SNMP versions vary in the level of security provided between the management station and the network device.

In SNMPv1 and SNMPv2c, user authentication is accomplished using 'community strings', which function like passwords. The remote user SNMP application and the Switch SNMP must use the same community string. SNMP packets from any station that has not been authenticated are ignored (dropped).

The default community strings for the Switch used for SNMPv1 and SNMPv2c management access are:

- **public** - Allows authorized management stations to retrieve MIB objects.
- **private** - Allows authorized management stations to retrieve and modify MIB objects.

SNMPv3 uses a more sophisticated authentication process that is separated into two parts. The first part is to maintain a list of users and their attributes that are allowed to act as SNMP managers. The second part describes what each user on that list can do as an SNMP manager.

The Switch allows groups of users to be listed and configured with a shared set of privileges. The SNMP version may also be set for a listed group of SNMP managers. Thus, a group of SNMP managers can be created to view read-only information or receive traps using SNMPv1 while assigning a higher level of security to another group, granting read/write privileges using SNMPv3.

Using SNMPv3 individual users or groups of SNMP managers can be allowed to perform or be restricted from performing specific SNMP management functions. The functions that have been allowed or restricted are defined using the Object Identifier (OID) associated with a specific MIB. An additional layer of security is available for SNMPv3 in that SNMP messages may be encrypted.

Traps

Traps are messages that are sent by an SNMP-enabled device to the NMS, and can be used to alert network personnel of events that occur on the Switch. The events can be as serious as a reboot (someone accidentally turned off the Switch), or less serious like a port status change. The Switch generates traps and sends them to a pre-configured IP address, usually an NMS. Typical traps include trap messages for Authentication Failure and Topology Change.

Management Information Base (MIB)

A Management Information Base (MIB) stores management and counter information. The Switch uses the standard MIB-II Management Information Base module. Consequently, values for MIB objects can be retrieved from any SNMP-based network management software. In addition to the standard MIB-II, the Switch also supports its own proprietary enterprise MIB as an extended Management Information Base. The proprietary MIB may also be retrieved by specifying the MIB Object Identifier. MIB values can be either read-only or read-write.

5. Web-based Switch Configuration

Introduction

Logging into the Web UI

Web User Interface (Web UI)

Introduction

Most software functions of the Switch can be managed, configured, and monitored via the embedded HTML Web UI. Management can be done on the Switch from remote stations anywhere on the network through a standard web browser. The web browser acts as a universal access tool and can communicate directly with the Switch using the HTTP or HTTPS (SSL) protocol.

The following web browsers are supported:

- Internet Explorer (version 8 and later)
- Firefox
- Google Chrome
- Safari

Logging into the Web UI

To access the Web UI, open a standard web browser, enter the Switch's IP address into the address bar of the browser, and press the ENTER key.



NOTE: The default IP address of this switch is **10.90.90.90**, with a subnet mask of **255.0.0.0**.



5-1 IP address in Internet Explorer



NOTE: The default username is `admin` and the default password is `admin`.

After pressing the ENTER key, the following authentication window should appear, as shown below.

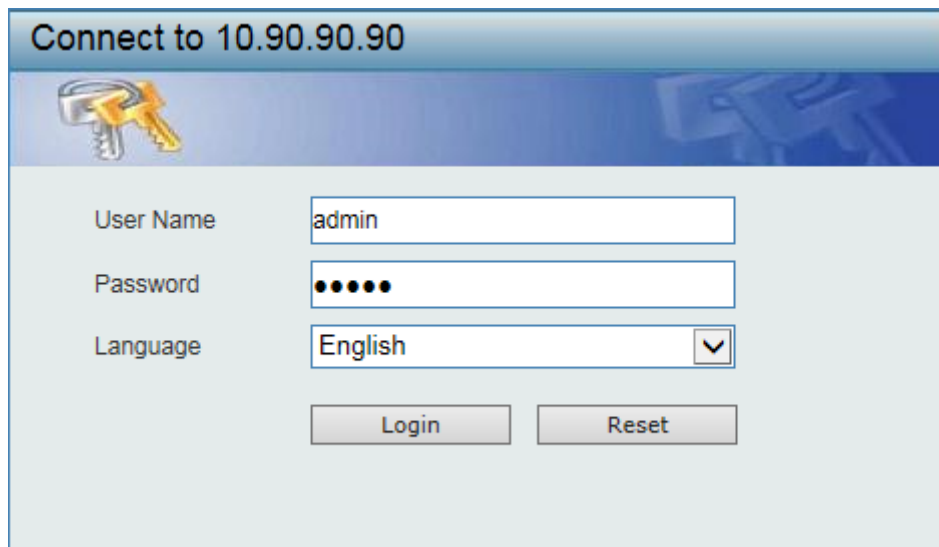

Figure 5-2 Web UI Login Window

Enter the **User Name** and **Password** in the corresponding fields and click Login. This will open the Web UI. Management features available in the Web UI of the Switch are explained below.

Web User Interface (Web UI)

The Web UI provides access to various Switch configuration and management windows. It allows the user to view performance statistics, and permits graphical monitoring of the system's status.

Areas of the Web UI

After logging into the Switch's Web UI, the following page will be displayed. The Web UI can be divided into four distinct areas that are described in more detail in the table below.



Figure 5-3 Main Web UI Window

Four main areas are displayed in the window.

Area Number	Function
AREA 1	This area displays a graphical, near real-time image of the front panel of the Switch. This area displays the Switch's ports and expansion modules. It also shows port activity based on a specific mode. Some management functions, including port monitoring, are accessible from here. Click the D-Link logo to go to the D-Link website.
AREA 2	This area displays a file explorer-type menu tree with all configurable options. Select the folder or window to display. Open folders and click the hyperlinked window buttons and subfolders contained within them to display information pertaining to that category.
AREA 3	This area displays a toolbar used to access Save and Tools menus.
AREA 4	This area displays graphical, real-time monitoring gauges of Device Information , CPU Usage , and Memory Usage .

Web Pages

In area 2, mentioned above, the following main folders will be available for selecting.

Folder Name	Description
System	Features regarding the Switch's configuration can be viewed and configured in this folder.
Management	Features regarding the Switch's management can be viewed and configured in this folder.
L2 Features	Features regarding the Layer 2 functionality of the Switch can be viewed and configured in this folder.
L3 Features	Features regarding the Layer 3 functionality of the Switch can be viewed and configured in this folder.
QoS	Features regarding the Quality of Service functionality of the Switch can be viewed and configured in this folder.
ACL	Features regarding the Access Control List functionality of the Switch can be viewed and configured in this folder.
Security	Features regarding the Switch's security can be viewed and configured in this folder.
OAM	Features regarding the Switch's Operations, Administration and Maintenance (OAM) can be viewed and configured in this folder.
Monitoring	The Switch's configuration and statistics can be viewed and configured in this folder.
Green	Features regarding the D-Link Green Technology can be viewed and configured in this folder.

Appendix A - Technical Specifications

General

Feature	Description		
Data Transfer Rates		Half-duplex	Full-duplex
	Ethernet	10 Mbps	20 Mbps
	Fast Ethernet	100 Mbps	200 Mbps
	Gigabit Ethernet	-	2 Gbps
	10 Gigabit Ethernet	-	20 Gbps
Network Cables	UTP/STP Category 3, 4, 5 for 10BASE-T UTP/STP Category.5, 5e for 100BASE-TX UTP/STP Category 5e for 1000BASE-T UTP/STP Category 6a for 10GBASE-T EIA/TIA-568 100-ohm screened twisted-pair (STP) (100m)		

Physical and Environmental

Feature	Description
Internal AC Power Supply	DGS-1250-28X: 100~240 VAC, 50~60 Hz, 0.9 A DGS-1250-28XMP: 100~240 VAC, 50~60 Hz, 6 A DGS-1250-52X: 100~240 VAC, 50~60 Hz, 2.5 A DGS-1250-52XMP: 100~240 VAC, 50~60 Hz, 6 A
Security Lock	Provides a Kensington-compatible security lock, on the rear panel of the Switch, to be able to connect to a secure immovable device. Insert the lock into the notch and turn the key to secure the lock. The lock-and-cable apparatus should be purchased separately
Fans	The IC Sensor detects the temperature on the switch automatically and adjusts the speed DGS-1250-28X: 1 fan DGS-1250-28XMP: 2 fans DGS-1250-52X: 1 fan DGS-1250-52XMP: 2 fans
Power Consumption	Maximum Power Consumption: DGS-1250-28X: 30.6 Watts (100 VAC), 29.6 Watts (240 VAC) DGS-1250-28XMP: 38.6 Watts (100 VAC, non-PoE), 445.1 Watts (100 VAC, PoE), 39.1 Watts (240 VAC, non-PoE), 431.5 Watts (240 VAC, PoE) DGS-1250-52X: 51.0 Watts (100 VAC), 51.2 Watts (240 VAC) DGS-1250-52XMP: 56.4 Watts (100 VAC, non-PoE), 467.3 Watts (100 VAC, PoE), 57.2 Watts (240 VAC, non-PoE), 443.6 Watts (240 VAC, PoE) Standby Power Consumption: DGS-1250-28X: 8.7 Watts (100 VAC), 9.3 Watts (240 VAC) DGS-1250-28XMP: 18.5 Watts (100 VAC), 19 Watts (240 VAC) DGS-1250-52X: 23.0 Watts (100 VAC), 23.5 Watts (240 VAC) DGS-1250-52XMP: 27.8 Watts (100 VAC), 28.4 Watts (240 VAC)

Feature	Description
Temperature	Operating: -5 °C to 50 °C (23 °F to 122 °F) Storage: -20 °C to 70 °C (-4 °F to 158 °F)
Humidity	Operating: 0 % to 95 % RH (non-condensing) Storage: 0 % to 95 % RH (non-condensing)
Heat Dissipation	DGS-1250-28X: 104.346 BTU/Hr (100 VAC), 100.936 BTU/Hr (240 VAC) DGS-1250-28XMP: 131.626 BTU/Hr (100 VAC, non-PoE), 1551.891 BTU/Hr (100 VAC, PoE), 133.331 BTU/Hr (240 VAC, non-PoE), 1471.415 BTU/Hr (240 VAC, PoE) DGS-1250-52X: 173.91 BTU/Hr (100 VAC), 174.592 BTU/Hr (240 VAC) DGS-1250-52XMP: 192.324 BTU/Hr (100 VAC, non-PoE), 1593.493 BTU/Hr (100 VAC, PoE), 195.052 BTU/Hr (240 VAC, non-PoE), 1512.676 BTU/Hr (240 VAC, PoE)
Dimensions	DGS-1250-28X: 441 mm (W) x 140 mm (D) x 44 mm (H), 19-inch, 1 U Rack-mount size DGS-1250-28XMP: 441 mm (W) x 250 mm (D) x 44 mm (H), 19-inch, 1 U Rack-mount size DGS-1250-52X: 441 mm (W) x 210 mm (D) x 44 mm (H), 19-inch, 1 U Rack-mount size DGS-1250-52XMP: 441 mm (W) x 250 mm (D) x 44 mm (H), 19-inch, 1 U Rack-mount size
Weight	DGS-1250-28X: 1.75 kg DGS-1250-28XMP: 3.46 kg DGS-1250-52X: 3.01 kg DGS-1250-52XMP: 3.85 kg
MTBF	DGS-1250-28X: 743482.4543 Hours (with AC power) DGS-1250-28XMP: 463430.1638 Hours (with AC power) DGS-1250-52X: 589984.721 Hours (with AC power) DGS-1250-52XMP: 309053.1045 Hours (with AC power)
EMC Certifications	CE Class A, FCC Class A, VCCI Report Class A, C-Tick Report Class A, BSMI, CCC
Safety Certifications	IEC60950-1, IEC62368-1, UL/CSA62368-1, BSMI, CCC

Performance

Feature	Description
Transmission Method	Store-and-forward
Packet Buffer	12 Mbits per device
Jumbo Frame Size	12 KBytes
Switching Capacity	DGS-1250-28X: 128 Gbps DGS-1250-28XMP: 128 Gbps DGS-1250-52X: 176 Gbps DGS-1250-52XMP: 176 Gbps
Maximum Packet Forwarding Rate	DGS-1250-28X: 95.24 Mpps DGS-1250-28XMP: 95.24 Mpps DGS-1250-52X: 130.95 Mpps DGS-1250-52XMP: 130.95 Mpps
Priority Queues	8 Priority Queues per port.

Feature	Description
MAC Address Table	DGS-1250-28X: 16K DGS-1250-28XMP: 16K DGS-1250-52X: 32K DGS-1250-52XMP: 32K Supports 256 Static MAC addresses

LED Indicators

Location	LED	Color	Status	Description	
Per Device	Power	Green	Light on (Solid)	Power on	
		Green	Light blinking	Performing System Self-test	
		Off	Light off	Power off	
	Console	Green	Light on (Solid)	RJ45 console port is active	
		Off	Light off	Console off	
	Fan Error	Red	Light on (Solid)	Fan fail	
		Off	Light off	Operating normally	
	PWR Max. (DGS-1250-28XMP and DGS-1250- 52XMP Only)	Red	Light on (Solid)	When the power supplied to attached PDs exceeds the maximum PoE budget.	
			Light blinking	When the power supplied to attached PDs approaches the maximum PoE budget (within 7 Watts) and enters the Guardband mode.	
		Off	Light off	When no power is supplied to attached PDs or when no PDs are attached.	
	Port LED Mode Indicator (DGS-1250-28XMP and DGS-1250- 52XMP Only)	An LED Mode Select Button to switch two modes in turn for all 10/100/1000Mbps ports on DGS-1250-28XMP/52XMP: <ul style="list-style-type: none"> Link/Act/Speed Mode PoE Mode 			
		Green	Light on (Solid)	An LED Mode Select Button to switch Link/Act/Speed Mode	
			Light on (Solid)	An LED Mode Select Button to switch PoE Mode	
LED Per 10/100/1000 Mbps Port	Link/Act/Speed Mode	Green	Light on (Solid)	When there is a connection (or link) to a 1000 Mbps Ethernet device on any of the ports	
			Light blinking	When there is reception or transmission of data occurring at 1000Mbps	
		Amber	Light on (Solid)	When there is a connection (or link) to a 10/100Mbps Ethernet device on any of the ports	
			Light blinking	When there is reception or transmission of data occurring at 10/100Mbps	
		Off	Light off	Link down or no link	
	PoE Mode	Green	Light on (Solid)	Power feeding.	
		Amber	Light on (Solid)	Error Condition.	
		Off	Light off	No Power feeding.	

Location	LED	Color	Status	Description
	(DGS-1250-28XMP and DGS-1250-52XMP Only)		Light blinking	When there is reception or transmission of data occurring at 100Mbps
		Off	Light off	Link down or no link
LED per SFP/SFP+ Port	Link/Act	Green	Light on (Solid)	When there is a connection (or link) to a 10Gbps Ethernet device on any of the ports
			Light blinking	When there is reception or transmission of data occurring at a 10Gbps port
		Amber	Light on (Solid)	When there is a connection (or link) to a 1000Mbps Ethernet device on any of the ports
			Light blinking	When there is reception or transmission of data occurring at a 1000 Mbps port
		Off	Light off	Link down or no link

Port Functions

Feature	Description
Console Port	RJ45interface for Out-Of-Band (OOB) CLI configuration
RJ45 Ports	Compliant with the following standards: <ul style="list-style-type: none"> • IEEE 802.3 compliance • IEEE 802.3u compliance • IEEE 802.3ab compliance • IEEE 802.3az compliance
	Support Half-Duplex and Full-Duplex operations <ul style="list-style-type: none"> • IEEE 802.3x Flow Control support for Full-Duplex mode • Back Pressure for Half-Duplex mode • Head-of-line blocking prevention • Manual/auto MDI/MDIX configuration • Auto-Negotiation for each port
SFP/SFP+ Ports	Compliant with the following standards: <ul style="list-style-type: none"> • IEEE 802.3ae compliance • IEEE 802.3z compliance
	SFP Transceivers Supported: <ul style="list-style-type: none"> • DEM-310GT (1000BASE-LX, single-mode, 10 km, with DDM) • DEM-311GT (1000BASE-SX, multi-mode, 550 m) • DEM-312GT2 (1000BASE-SX, multi-mode, 2 km) • DEM-314GT (1000BASE-LHX, single-mode, 50 km) • DEM-315GT (1000BASE-ZX, single-mode, 80 km) • DGS-712 (1000BASE-T)
	WDM (BiDi) SFP Transceivers Supported: <ul style="list-style-type: none"> • DEM-330T (1000BASE-BX-D, single-mode, 10 km, TX: 1550 nm / RX: 1310 nm) • DEM-330R (1000BASE-BX-U, single-mode, 10 km, TX: 1310 nm / RX: 1550 nm) • DEM-331T (1000BASE-BX-D, single-mode, 40 km, TX: 1550 nm / RX: 1310 nm)

Feature	Description																		
	<ul style="list-style-type: none"> DEM-331R (1000BASE-BX-U, single-mode, 40 km, TX: 1310 nm / RX: 1550 nm) <p>SFP+ Transceivers Supported:</p> <ul style="list-style-type: none"> DEM-431XT (10GBASE-SR, multi-mode, 80 km, without DDM) DEM-432XT (10GBASE-LR, single-mode, 10 km, without DDM) DEM-433XT (10GBASE-ER, single-mode, 40 km, without DDM) DEM-434XT (10GBASE-ZR, single-mode, 80 km, without DDM) DEM-410T (10GBASE-T Copper SFP+) <p>WDM (BiDi) SFP+ Transceivers Supported:</p> <ul style="list-style-type: none"> DEM-436XT-BXD (10GBASE-LR, single-mode, 20 km, TX: 1330 nm / RX: 1270 nm, without DDM) DEM-436XT-BXU (10GBASE-LR, single-mode, 20 km, TX: 1270 nm / RX: 1310 nm, without DDM) <p>SFP+ Direct Attached Cables (DAC) Supported:</p> <ul style="list-style-type: none"> DEM-CB100S (10G SFP+, 1 m) for stacking or uplinking DEM-CB300S (10G SFP+, 3m) for stacking or uplinking 																		
<p>PoE Ports (DGS-1250-28XMP and DGS-1250-52XMP Only)</p>	<p>Supports the following:</p> <ul style="list-style-type: none"> IEEE 802.3af PoE and IEEE 802.3at PoE+ compliance Power (DGS-1250-28XMP: Ports 1 to 24 and DGS-1250-52XMP: Ports 1 to 48) to PD devices up to 15.4 Watt per port (802.3af) or 30 Watt per port (802.3at) and more sufficiently is able to provide power to PD devices The auto-discovery feature automatically recognizes the connection of the PD device and immediately provides power Automatically disable ports if the port current is over 600mA while. Other ports will remain active Active circuit protection automatically disables the port if there is a short while other ports remain active For 802.3af/at capable devices it will provide the power for the following classifications below: <table border="1" data-bbox="531 1317 1506 1603"> <thead> <tr> <th>Class</th> <th>Usage</th> <th>Max Power used by PD</th> </tr> </thead> <tbody> <tr> <td>0</td> <td>Default</td> <td>0.44 Watt to 12.95 Watt</td> </tr> <tr> <td>1</td> <td>Optional</td> <td>0.44 Watt to 3.84 Watt</td> </tr> <tr> <td>2</td> <td>Optional</td> <td>3.84 Watt to 6.49 Watt</td> </tr> <tr> <td>3</td> <td>Optional</td> <td>6.49 Watt to 12.95 Watt</td> </tr> <tr> <td>4</td> <td>Optional (802.3at Only)</td> <td>12.95 Watt to 25.5 Watt</td> </tr> </tbody> </table> <ul style="list-style-type: none"> For 802.3af/at capable devices it will provide the power for the following classifications below: The PoE switch works with all D-Link 802.3af and 802.3at capable devices and with all non-802.3af and non-802.3at capable D-Link Access Points, IP Cameras and IP Phones The total PoE power budget of the: <ul style="list-style-type: none"> DGS-1250-28XMP is 370 Watts DGS-1250-52XMP is 370 Watts 	Class	Usage	Max Power used by PD	0	Default	0.44 Watt to 12.95 Watt	1	Optional	0.44 Watt to 3.84 Watt	2	Optional	3.84 Watt to 6.49 Watt	3	Optional	6.49 Watt to 12.95 Watt	4	Optional (802.3at Only)	12.95 Watt to 25.5 Watt
Class	Usage	Max Power used by PD																	
0	Default	0.44 Watt to 12.95 Watt																	
1	Optional	0.44 Watt to 3.84 Watt																	
2	Optional	3.84 Watt to 6.49 Watt																	
3	Optional	6.49 Watt to 12.95 Watt																	
4	Optional (802.3at Only)	12.95 Watt to 25.5 Watt																	

Appendix B - Cables and Connectors

Ethernet Cable

When connecting the Switch to another switch, a bridge or hub, a straight-through Cat5/5e/6a/7 cable is necessary. Please review these products for matching cable pin assignment.

The following diagrams and tables show the standard RJ45 receptacle/connector and their pin assignments.

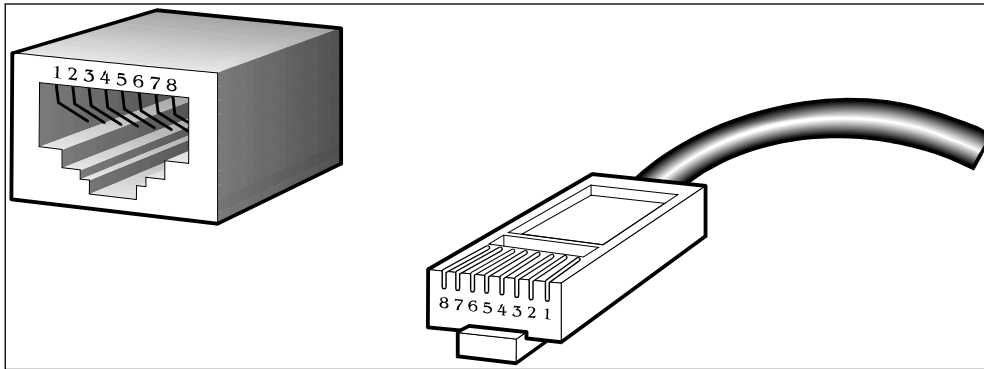

Figure B-1 Standard RJ45 port and connector

RJ45 Pin Assignment

Contact	MDI-X Port	MDI-II Port
1	RD+ (receive)	TD+ (transmit)
2	RD - (receive)	TD - (transmit)
3	TD+ (transmit)	RD+ (receive)
4	1000BASE-T	1000BASE-T
5	1000BASE-T	1000BASE-T
6	TD - (transmit)	RD- (receive)
7	1000BASE-T	1000BASE-T
8	1000BASE-T	1000BASE-T

Console Cable (RJ45 to RS-232)

A console cable is used to connect to the RJ45 console port of the Switch to access the command line interface. The following diagram and table show the standard RJ45 to RS-232 cable and pin assignments.

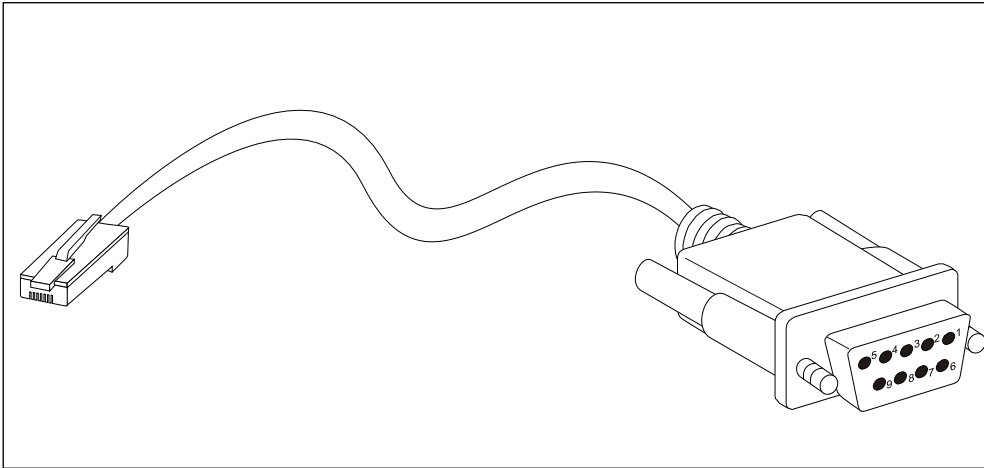

Figure B-2 Console to RJ45 Cable

Contact	Console (DB9/RS232)	RJ45
1	Not Used	Not Used
2	RXD	Not Used
3	TXD	TXD
4	Not Used	GND
5	GND (shared)	GND
6	Not Used	RXD
7	Not Used	Not Used
8	Not Used	Not Used

Safety/Sécurité

Safety Instructions

Please pay careful attention to the following safety guidelines to ensure your own personal safety and to help protect your system from potential damage.

Safety Cautions

To greatly reduce the risk of physical injury, electrical shock, fire, and damage to equipment, observe the following precautions.

Observe and follow service markings.

- Do not attempt to service any product, except when it is explained in the system's documentation.
- Opening or removing covers, marked with a high voltage sign, may expose the user to electrical shock.
- Only a trained service technician should service components inside these compartments.

If any of the following conditions occur, unplug the product from the electrical outlet and replace the part or contact your trained service provider:

- Damage to the power cable, extension cable, or plug.
- An object has fallen into the product.
- The product has been exposed to water.
- The product has been dropped or damaged.
- The product does not operate correctly when the operating instructions are correctly followed.

General safety cautions:

- **Electrical Hazard:** Only qualified personnel should perform installation procedures.
- Before servicing, disconnect all power cords to remove power from the device.
- Keep the system away from radiators and heat sources. Also, do not block cooling vents.
- Do not spill food or liquids on system components, and never operate the product in a wet environment. If the system gets wet contact your trained service provider.
- Do not push any objects into the openings of the system. Doing so can cause fire or electric shock by shorting out interior components.
- Only use this product with approved equipment.
- Allow the product to cool before removing the cover or touching internal components.
- Operate the product only from the type of external power source indicated on the electrical ratings label. If unsure of the type of power source required, consult your service provider or local power company.
- Be sure that attached devices are electrically rated to operate with the power available in your location.
- Use only approved power cable(s). If you have not been provided with a power cable for your system or for any AC-powered option intended for your system, purchase a power cable that is approved for use in your country. The power cable must be rated for the product and for the voltage and current marked on the product's electrical ratings label. The voltage and current rating of the cable should be greater than the ratings marked on the product.
- To help prevent electric shock, plug the system and peripheral power cables into properly grounded electrical outlets. These cables are equipped with three-prong plugs to help ensure proper grounding. Do not use adapter plugs or remove the grounding prong from a cable. If using an extension cable is necessary, use a 3-wire cable with properly grounded plugs.
- Observe the extension cable and power strip ratings. Make sure that the total ampere rating of all products plugged into the extension cable or power strip does not exceed 80 percent of the ampere ratings limit for the extension cable or power strip.
- To help protect the system from sudden, transient increases and decreases in electrical power, use a surge suppressor, line conditioner, or uninterruptible power supply (UPS).
- Position system cables and power cables carefully. Route cables so that they cannot be stepped on or tripped over. Be sure that nothing rests on any cables.
- Do not modify power cables or plugs. Consult a licensed electrician or your power company for site modifications. Always follow your local or national wiring rules.

When connecting or disconnecting power to and from hot-pluggable power supplies, observe the following guidelines:

- Install the power supply before connecting the power cable to the power supply.
- Unplug the power cable before removing the power supply.
- If the system has multiple sources of power, disconnect power from the system by unplugging all power cables from the power supplies.
- Move products with care and ensure that all casters and stabilizers are firmly connected to the system. Avoid sudden stops and uneven surfaces.

To help avoid damage to the system, be sure that the voltage selection switch, on the power supply, is set to match the power available at the Switch's location:

- 115V/60Hz is used mostly in North and South America as well as Far Eastern countries like as South Korea and Taiwan
- 100V/50Hz is used mostly in Eastern Japan and 100V/60Hz in Western Japan
- 230V/50Hz is used mostly in Europe, the Middle East, Africa and the Far East

Consignes de sécurité

Veillez prêter une attention particulière aux consignes de sécurité suivantes pour assurer votre sécurité personnelle et protéger votre système des dommages potentiels.

Précautions de sécurité

Pour réduire considérablement les risques de blessure physique, de choc électrique, d'incendie et de détérioration du matériel, observez les précautions suivantes.

Observez et respectez les marquages relatifs à l'entretien et/ou aux réparations.

- N'essayez pas de réparer un produit, sauf si cela est expliqué dans la documentation du système.
- L'ouverture ou le retrait des capots, signalés par un symbole de haute tension, peut exposer l'utilisateur à un choc électrique.
- Seul un technicien de maintenance qualifié est habilité à réparer les composants à l'intérieur de ces compartiments.

Si l'un des cas suivants se produit, débranchez l'appareil du secteur et remplacez la pièce concernée ou contactez votre prestataire de services agréé.

- Endommagement du câble d'alimentation, du câble de rallonge ou de la fiche.
- Un objet est tombé dans le produit.
- Le produit a été exposé à l'eau.
- Le produit est tombé ou a été endommagé.
- Le produit ne fonctionne pas correctement lorsque les instructions d'utilisation sont correctement suivies.

Précautions générales de sécurité :

- Danger électrique : Seul le personnel qualifié doit effectuer les procédures d'installation.
- Avant de procéder à l'entretien, débranchez tous les cordons d'alimentation pour mettre le périphérique hors tension.
- Eloignez le système des radiateurs et des sources de chaleur. Par ailleurs, n'obturez pas les fentes d'aération.
- Ne versez pas de liquide sur les composants du système et n'introduisez pas de nourriture à l'intérieur. Ne faites jamais fonctionner l'appareil dans un environnement humide. Si le système est mouillé, contactez votre prestataire de services qualifié.
- N'insérez aucun objet dans les fentes de l'appareil. Vous risqueriez de provoquer un incendie ou un choc électrique en court-circuitant les composants internes.
- Utilisez ce produit uniquement avec un équipement approuvé.
- Laissez l'appareil refroidir avant de déposer le capot ou de toucher les composants internes.
- Faites fonctionner le produit uniquement avec la source d'alimentation indiquée sur l'étiquette signalétique où figurent les caractéristiques électriques nominales. Si vous ne savez pas avec certitude quel type de source d'alimentation est requis, consultez votre prestataire de services ou votre compagnie d'électricité.

- Assurez-vous que les caractéristiques nominales des appareils branchés correspondant à la tension du réseau électrique.
- Utilisez uniquement des câbles d'alimentation homologués. Si un câble d'alimentation n'est pas fourni pour le système ou pour un composant/accessoire alimenté par CA destiné au système, procurez-vous un câble d'alimentation homologué pour une utilisation dans votre pays. Le câble d'alimentation doit être adapté à l'appareil et ses caractéristiques nominales doivent correspondre à celles figurant sur l'étiquette du produit. La tension et le courant nominaux du câble doivent être supérieurs aux valeurs nominales indiquées sur l'appareil.
- Pour éviter tout risque de choc électrique, branchez les câbles d'alimentation du système et des périphériques à des prises électriques correctement mises à la masse. Ces câbles sont équipés de fiches à trois broches pour garantir une mise à la masse appropriée. N'utilisez pas d'adaptateur de prise, et n'éliminez pas la broche de mise à la masse du câble. Si un câble de rallonge est nécessaire, utilisez un câble à 3 fils avec des fiches correctement mises à la terre.
- Respectez les caractéristiques nominales de la rallonge ou du bloc multiprise. Assurez-vous que l'intensité nominale totale de tous les produits branchés à la rallonge ou au bloc multiprise ne dépasse pas 80 % de l'intensité nominale limite de la rallonge ou du bloc multiprise.
- Pour protéger le système contre les pics et les chutes de tension transitoires et soudains, utilisez un parasurtenseur, un filtre de secteur ou une alimentation sans interruption (ASI).
- Positionnez les câbles système et les câbles d'alimentation avec soin. Acheminez les câbles de manière à ce qu'ils ne puissent pas être piétinés ou trébuchés. Veillez à ce que rien ne repose sur les câbles.
- Ne modifiez pas les câbles ou les fiches d'alimentation. Contactez un électricien qualifié ou la compagnie d'électricité si des modifications sur site sont nécessaires. Respectez toujours la réglementation locale ou nationale en matière de câblage.

Lors de la connexion ou de la déconnexion de l'alimentation vers et depuis des blocs d'alimentation enfichables à chaud, respectez les consignes suivantes :

- Installez l'alimentation avant d'y brancher le câble d'alimentation.
- Débranchez le câble d'alimentation avant de couper l'alimentation.
- Si le système possède plusieurs sources d'alimentation, mettez-le hors tension en débranchant tous les câbles d'alimentation des prises.
- Déplacez les appareils avec précaution et assurez-vous que les roulettes et/ou que les pieds stabilisateurs sont bien fixés au système. Évitez les arrêts brusques et les surfaces inégales.

Pour éviter d'endommager le système, assurez-vous que le commutateur de sélection de tension de l'alimentation est réglé sur l'alimentation disponible à l'emplacement du commutateur :

- 115 V/60 Hz est principalement utilisé en Amérique du Nord et du Sud, ainsi que dans des pays d'Extrême-Orient tels que la Corée du Sud et Taïwan.
- 100 V/50 Hz est utilisé principalement dans l'est du Japon et 100 V/ 60 Hz dans l'ouest du Japon.
- 230 V/50 Hz est principalement utilisé en Europe, au Moyen-Orient, en Afrique et en Extrême-Orient.

General Precautions for Rack-Mountable Products

Please pay careful attention to the following precautions concerning rack stability and safety. Systems are considered to be components in a rack. Thus, a component refers to any system, as well as to various peripherals or supporting hardware:

CAUTION: Installing systems in a rack without the front and side stabilizers installed could cause the rack to tip over, potentially resulting in bodily injury under certain circumstances. Therefore, always install the stabilizers before installing components in the rack. After installing system/components in a rack, never pull more than one component out of the rack on its slide assemblies at one time. The weight of more than one extended component could cause the rack to tip over and may result in serious injury.



ATTENTION : Le montage de systèmes sur un rack dépourvu de pieds stabilisateurs avant et latéraux peut faire basculer le rack, pouvant causer des dommages corporels dans certains cas. Par conséquent, installez toujours les pieds stabilisateurs avant de monter des composants sur le rack. Après l'installation d'un système ou de composants dans un rack, ne sortez jamais plus d'un composant à la fois hors du rack sur ses glissières. Le poids de plusieurs composants sur les glissières en extension peut faire basculer le rack, pouvant causer de graves dommages corporels.

- Before working on the rack, make sure that the stabilizers are secured to the rack, extended to the floor, and that the full weight of the rack rests on the floor. Install front and side stabilizers on a single rack or front stabilizers for joined multiple racks before working on the rack.
- Always load the rack from the bottom up, and load the heaviest item in the rack first.
- Make sure that the rack is level and stable before extending a component from the rack.
- Use caution when pressing the component rail release latches and sliding a component into or out of a rack; the slide rails can pinch your fingers.
- After a component is inserted into the rack, carefully extend the rail into a locking position, and then slide the component into the rack.
- Do not overload the AC supply branch circuit that provides power to the rack. The total rack load should not exceed 80 percent of the branch circuit rating.
- Ensure that proper airflow is provided to components in the rack.
- Do not step on or stand on any component when servicing other components in a rack.

CAUTION: Never defeat the ground conductor or operate the equipment in the absence of a suitably installed ground conductor. Contact the appropriate electrical inspection authority or an electrician if uncertain that suitable grounding is available.



ATTENTION : Ne neutralisez jamais le conducteur de masse et ne faites jamais fonctionner le matériel en l'absence de conducteur de masse dûment installé. Contactez l'organisme de contrôle en électricité approprié ou un électricien qualifié si vous n'êtes pas sûr qu'un système de mise à la masse adéquat soit disponible.

CAUTION: The system chassis must be positively grounded to the rack cabinet frame. Do not attempt to connect power to the system until grounding cables are connected. Completed power and safety ground wiring must be inspected by a qualified electrical inspector. An energy hazard will exist if the safety ground cable is omitted or disconnected.



ATTENTION : La carcasse du système doit être positivement reliée à la masse du cadre du rack. N'essayez pas de mettre le système sous tension si les câbles de mise à la masse ne sont pas raccordés. Le câblage de l'alimentation et de la mise à la masse de sécurité doit être inspecté par un inspecteur qualifié en électricité. Un risque électrique existe si le câble de mise à la masse de sécurité est omis ou débranché.

Protecting Against Electrostatic Discharge

Static electricity can harm delicate components inside the system. To prevent static damage, discharge static electricity from your body before touching any of the electronic components, such as the microprocessor. This can be done by periodically touching an unpainted metal surface on the chassis.

The following steps can also be taken prevent damage from electrostatic discharge (ESD):

- When unpacking a static-sensitive component from its shipping carton, do not remove the component from the antistatic packing material until ready to install the component in the system. Just before unwrapping the antistatic packaging, be sure to discharge static electricity from your body.
- When transporting a sensitive component, first place it in an antistatic container or packaging.
- Handle all sensitive components in a static-safe area. If possible, use antistatic floor pads, workbench pads and an antistatic grounding strap.

Subject to the terms and conditions set forth herein, D-Link Systems, Inc. ("D-Link") provides this Limited Warranty:

- Only to the person or entity that originally purchased the product from D-Link or its authorized reseller or distributor, and
- Only for products purchased and delivered within the fifty states of the United States, the District of Columbia, U.S. Possessions or Protectorates, U.S. Military Installations, or addresses with an APO or FPO.

Limited Warranty: D-Link warrants that the hardware portion of the D-Link product described below ("Hardware") will be free from material defects in workmanship and materials under normal use from the date of original retail purchase of the product, for the period set forth below ("Warranty Period"), except as otherwise stated herein.

Limited Lifetime Warranty for the product is defined as follows:

- Hardware: For as long as the original customer/end user owns the product, or five (5) years after product discontinuance, whichever occurs first (excluding power supplies and fans)
- Power supplies and fans: Three (3) Year
- Spare parts and spare kits: Ninety (90) days

The customer's sole and exclusive remedy and the entire liability of D-Link and its suppliers under this Limited Warranty will be, at D-Link's option, to repair or replace the defective Hardware during the Warranty Period at no charge to the original owner or to refund the actual purchase price paid. Any repair or replacement will be rendered by D-Link at an Authorized D-Link Service Office. The replacement hardware need not be new or have an identical make, model or part. D-Link may, at its option, replace the defective Hardware or any part thereof with any reconditioned product that D-Link reasonably determines is substantially equivalent (or superior) in all material respects to the defective Hardware. Repaired or replacement hardware will be warranted for the remainder of the original Warranty Period or ninety (90) days, whichever is longer, and is subject to the same limitations and exclusions. If a material defect is incapable of correction, or if D-Link determines that it is not practical to repair or replace the defective Hardware, the actual price paid by the original purchaser for the defective Hardware will be refunded by D-Link upon return to D-Link of the defective Hardware. All Hardware or part thereof that is replaced by D-Link, or for which the purchase price is refunded, shall become the property of D-Link upon replacement or refund.

Limited Software Warranty: D-Link warrants that the software portion of the product ("Software") will substantially conform to D-Link's then current functional specifications for the Software, as set forth in the applicable documentation, from the date of original retail purchase of the Software for a period of ninety (90) days ("Software Warranty Period"), provided that the Software is properly installed on approved hardware and operated as contemplated in its documentation. D-Link further warrants that, during the Software Warranty Period, the magnetic media on which D-Link delivers the Software will be free of physical defects. The customer's sole and exclusive remedy and the entire liability of D-Link and its suppliers under this Limited Warranty will be, at D-Link's option, to replace the non-conforming Software (or defective media) with software that substantially conforms to D-Link's functional specifications for the Software or to refund the portion of the actual purchase price paid that is attributable to the Software. Except as otherwise agreed by D-Link in writing, the replacement Software is provided only to the original licensee, and is subject to the terms and conditions of the license granted by D-Link for the Software. Replacement Software will be warranted for the remainder of the original Warranty Period and is subject to the same limitations and exclusions. If a material non-conformance is incapable of correction, or if D-Link determines in its sole discretion that it is not practical to replace the non-conforming Software, the price paid by the original licensee for the non-conforming Software will be refunded by D-Link; provided that the non-conforming Software (and all copies thereof) is first returned to D-Link. The license granted respecting any Software for which a refund is given automatically terminates.

Non-Applicability of Warranty: The Limited Warranty provided hereunder for Hardware and Software portions of D-Link's products will not be applied to and does not cover any refurbished product and any product purchased through the inventory clearance or liquidation sale or other sales in which D-Link, the sellers, or the liquidators expressly disclaim their warranty obligation pertaining to the product and in that case, the product is being sold "As-Is" without any warranty whatsoever including, without limitation, the Limited Warranty as described herein, notwithstanding anything stated herein to the contrary.

Submitting A Claim: The customer shall return the product to the original purchase point based on its return policy. In case the return policy period has expired and the product is within warranty, the customer shall submit a claim to D-Link as outlined below:

- The customer must submit with the product as part of the claim a written description of the Hardware defect or Software nonconformance in sufficient detail to allow D-Link to confirm the same, along with proof of purchase of the product (such as a copy of the dated purchase invoice for the product) if the product is not registered.
- The customer must obtain a Case ID Number from D-Link Technical Support at 1-877-453-5465, who will attempt to assist the customer in resolving any suspected defects with the product. If the product is considered defective, the customer must obtain a Return Material Authorization ("RMA") number by completing the RMA form and entering the assigned Case ID Number at <https://rma.dlink.com/>.
- After an RMA number is issued, the defective product must be packaged securely in the original or other suitable shipping package to ensure that it will not be damaged in transit, and the RMA number must be prominently marked on the outside of the package. Do not include any manuals or accessories in the shipping package. D-Link will only replace the defective portion of the product and will not ship back any accessories.
- The customer is responsible for all in-bound shipping charges to D-Link. No Cash on Delivery ("COD") is allowed. Products sent COD will either be rejected by D-Link or become the property of D-Link. Products shall be fully insured by the customer and shipped to **D-Link Systems, Inc., 17595 Mt. Herrmann, Fountain Valley, CA 92708**. D-Link will not be held responsible for any packages that are lost in transit to D-Link. The repaired or replaced packages will be shipped to the customer via UPS Ground or any common carrier selected by D-Link. Return shipping charges shall be prepaid by D-Link if you use an address in the United States, otherwise we will ship the product to you freight collect. Expedited shipping is available upon request and provided shipping charges are prepaid by the customer.

D-Link may reject or return any product that is not packaged and shipped in strict compliance with the foregoing requirements, or for which an RMA number is not visible from the outside of the package. The product owner agrees to pay D-Link's reasonable handling and return shipping charges for any product that is not packaged and shipped in accordance with the foregoing requirements, or that is determined by D-Link not to be defective or non-conforming.

What Is Not Covered: The Limited Warranty provided herein by D-Link does not cover: Products that, in D-Link's judgment, have been subjected to abuse, accident, alteration, modification, tampering, negligence, misuse, faulty installation, lack of reasonable care, repair or service in any way that is not contemplated in the documentation for the product, or if the model or serial number has been altered, tampered with, defaced or removed; Initial installation, installation and removal of the product for repair, and shipping costs; Operational adjustments covered in the operating manual for the product, and normal maintenance; Damage that occurs in shipment, due to act of God, failures due to power surge, and cosmetic damage; Any hardware, software, firmware or other products or services provided by anyone other than D-Link; and Products that have been purchased from inventory clearance or liquidation sales or other sales in which D-Link, the sellers, or the liquidators expressly disclaim their warranty obligation pertaining to the product. While necessary maintenance or repairs on your Product can be performed by any company, we recommend that you use only an Authorized D-Link Service Office. Improper or incorrectly performed maintenance or repair voids this Limited Warranty.

Disclaimer of Other Warranties: EXCEPT FOR THE LIMITED WARRANTY SPECIFIED HEREIN, THE PRODUCT IS PROVIDED "AS-IS" WITHOUT ANY WARRANTY OF ANY KIND WHATSOEVER INCLUDING, WITHOUT LIMITATION, ANY WARRANTY OF MERCHANTABILITY, FITNESS FOR A PARTICULAR PURPOSE AND NON-INFRINGEMENT. IF ANY IMPLIED WARRANTY CANNOT BE DISCLAIMED IN ANY TERRITORY WHERE A PRODUCT IS SOLD, THE DURATION OF SUCH IMPLIED WARRANTY SHALL BE LIMITED TO NINETY (90) DAYS. EXCEPT AS EXPRESSLY COVERED UNDER THE LIMITED WARRANTY PROVIDED HEREIN, THE ENTIRE RISK AS TO THE QUALITY, SELECTION AND PERFORMANCE OF THE PRODUCT IS WITH THE PURCHASER OF THE PRODUCT.

Limitation of Liability: TO THE MAXIMUM EXTENT PERMITTED BY LAW, D-LINK IS NOT LIABLE UNDER ANY CONTRACT, NEGLIGENCE, STRICT LIABILITY OR OTHER LEGAL OR EQUITABLE THEORY FOR ANY LOSS OF USE OF THE PRODUCT, INCONVENIENCE OR DAMAGES OF ANY CHARACTER, WHETHER DIRECT, SPECIAL, INCIDENTAL OR CONSEQUENTIAL (INCLUDING, BUT NOT LIMITED TO, DAMAGES FOR LOSS OF GOODWILL, LOSS OF REVENUE OR PROFIT, WORK STOPPAGE, COMPUTER FAILURE OR MALFUNCTION, FAILURE OF OTHER EQUIPMENT OR COMPUTER PROGRAMS TO WHICH D-LINK'S PRODUCT IS CONNECTED WITH, LOSS OF INFORMATION OR DATA CONTAINED IN, STORED ON, OR INTEGRATED WITH ANY PRODUCT RETURNED TO D-LINK FOR WARRANTY SERVICE) RESULTING FROM THE USE OF THE PRODUCT, RELATING TO WARRANTY SERVICE, OR ARISING OUT OF ANY BREACH OF THIS LIMITED WARRANTY, EVEN IF D-LINK HAS BEEN ADVISED OF THE POSSIBILITY OF SUCH DAMAGES. THE SOLE REMEDY FOR A BREACH OF THE FOREGOING LIMITED WARRANTY IS REPAIR, REPLACEMENT OR REFUND OF THE DEFECTIVE OR NON-CONFORMING PRODUCT. THE MAXIMUM LIABILITY OF D-LINK UNDER THIS WARRANTY IS LIMITED TO THE PURCHASE PRICE OF THE PRODUCT COVERED BY THE WARRANTY. THE FOREGOING EXPRESS WRITTEN WARRANTIES AND REMEDIES ARE EXCLUSIVE AND ARE IN LIEU OF ANY OTHER WARRANTIES OR REMEDIES, EXPRESS, IMPLIED OR STATUTORY.

Governing Law: This Limited Warranty shall be governed by the laws of the State of California. Some states do not allow exclusion or limitation of incidental or consequential damages, or limitations on how long an implied warranty lasts, so the foregoing limitations and exclusions may not apply. This Limited Warranty provides specific legal rights and you may also have other rights which vary from state to state.

Trademarks: D-Link is a registered trademark of D-Link Systems, Inc. Other trademarks or registered trademarks are the property of their respective owners.

Copyright Statement: No part of this publication or documentation accompanying this product may be reproduced in any form or by any means or used to make any derivative such as translation, transformation, or adaptation without permission from D-Link Corporation/D-Link Systems, Inc., as stipulated by the United States Copyright Act of 1976 and any amendments thereto. Contents are subject to change without prior notice. Copyright 2004 by D-Link Corporation/D-Link Systems, Inc. All rights reserved.

CE Mark Warning: This is a Class A product. In a residential environment, this product may cause radio interference, in which case the user may be required to take adequate measures.

FCC Statement: This equipment has been tested and found to comply with the limits for a Class A digital device, pursuant to part 15 of the FCC Rules. These limits are designed to provide reasonable protection against harmful interference in a commercial installation. This equipment generates, uses, and can radiate radio frequency energy and, if not installed and used in accordance with the instructions, may cause harmful interference to radio communication. However, there is no guarantee that interference will not occur in a particular installation. Operation of this equipment in a residential environment is likely to cause harmful interference to radio or television reception. If this equipment does cause harmful interference to radio or television reception, which can be determined by turning the equipment off and on, the user is encouraged to try to correct the interference by one or more of the following measures:

- Reorient or relocate the receiving antenna.
- Increase the separation between the equipment and receiver.
- Connect the equipment into an outlet on a circuit different from that to which the receiver is connected.
- Consult the dealer or an experienced radio/TV technician for help.

For detailed warranty information applicable to products purchased outside the United States, please contact the corresponding local D-Link office.

Product Registration

*Register your D-Link product online at <http://support.dlink.com/register/>
Product registration is entirely voluntary and failure to complete or return this form will not diminish your warranty rights.*

Technical Support

U.S. and Canadian customers

This guide is only for initial configuration. Please refer to the user manual to learn more or visit <http://www.mydlink.com> for more information. Also feel free to contact us. U.S. and Canadian customers can contact D-Link Technical Support through our website.

USA

<http://support.dlink.com>

Canada

<http://support.dlink.ca>

Europe customers

TECHNICAL SUPPORT	dlink.com/support
TECHNISCHE UNTERSTÜTZUNG	
ASSISTANCE TECHNIQUE	
ASISTENCIA TÉCNICA	
SUPPORTO TECNICO	
TECHNISCHE ONDERSTEUNING	
POMOC TECHNICZNA	
TECHNICKÁ PODPORA	
TECHNICKÁ PODPORA	
TECHNIKAI TÁMOGATÁS	
TEKNISK SUPPORT	
TEKNISK SUPPORT	
TEKNISK STØTTE	
TEKNINEN TUKI	
ASSISTÊNCIA TÉCNICA	
ΤΕΧΝΙΚΗ ΥΠΟΣΤΗΡΙΞΗ	
TEHNIČKA PODRŠKA	
TEHNIČNA PODPORA	
SUPPORT TEHNIC	
ТЕХНИЧЕСКА ПОДДРЪЖКА	

Australia customers

Tel: 1300-700-100

24/7 Technical Support

Web: <http://www.dlink.com.au>

E-mail: support@dlink.com.au

India customers

Tel: +91-832-2856000 or 1860-233-3999

Web: www.dlink.co.in

E-Mail: helpdesk@in.dlink.com

Singapore, Thailand, Indonesia, Malaysia, Philippines, Vietnam customers

Singapore - www.dlink.com.sg

Thailand - www.dlink.co.th

Indonesia - www.dlink.co.id

Malaysia - www.dlink.com.my

Philippines - www.dlink.com.ph

Vietnam - www.dlink.com.vn

Korea customers

Tel : 1899-3540

Monday to Friday 9:30am to 6:30pm

Web : <http://d-link.co.kr>

E-mail : support@kr.dlink.com

New Zealand customers

Tel: 0800-900-900

24/7 Technical Support

Web: <http://www.dlink.co.nz>

E-mail: support@dlink.co.nz

South Africa and Sub Sahara Region customers

Tel: +27 12 661 2025

08600 DLINK (for South Africa only)

Monday to Friday 8:30am to 9:00pm South Africa Time

Web: <http://www.d-link.co.za>

E-mail: support@za.dlink.com

D-Link Middle East

Dubai, U.A.E.

Tel: +971-4-8809022

Fax: +971-4-8809066 / 8809069

Technical Support: +971-4-8809033

General Inquiries: info.me@me.dlink.com

Tech Support: support.me@me.dlink.com

Egypt:

Technical Support Call Center: +20 2258 66777

General Inquiries: info.eg@me.dlink.com

Tech Support : support.eg@me.dlink.com

Kingdom of Saudi Arabia:

Technical Support:

+966 1121 70009

General Inquiries: info.sa@me.dlink.com

Tech Support: support.sa@me.dlink.com

Pakistan:

Technical Support: +92-21-34548310, 34305069

General Inquiries: info.pk@me.dlink.com

Tech Support: support.pk@me.dlink.com

Morocco:

Phone office: +212 700 13 14 15

Email: morocco@me.dlink.com

Bahrain:

Technical Support: +973 1 3332904

Tech Support: support.me@me.dlink.com

Kuwait:

Tech Support: kuwait@me.dlink.com

Техническая Поддержка

Обновления программного обеспечения и документация доступны на Интернет-сайте D-Link.

D-Link предоставляет бесплатную поддержку для клиентов в течение гарантийного срока.

Клиенты могут обратиться в группу технической поддержки D-Link по телефону или через Интернет.

Техническая поддержка компании D-Link работает в круглосуточном режиме ежедневно, кроме официальных праздничных дней. Звонок бесплатный по всей России.

Техническая поддержка D-Link:

8-800-700-5465

Техническая поддержка через Интернет:

<http://www.dlink.ru>

e-mail: support@dlink.ru

Изготовитель:

Д-Линк Корпорейшн, 114, Тайвань, Тайпей, Нэйху Дистрикт, Шинху 3-Роуд, № 289

Уполномоченный представитель, импортер:

ООО "Д-Линк Трейд"

390043, г.Рязань, пр. Шабулина, д.16

Тел.: +7 (4912) 503-505

Офисы

Россия

Москва, Графский переулок, 14

Тел. : +7 (495) 744-00-99

E-mail: mail@dlink.ru

Україна

Київ, вул. Межигірська, 87-А

Тел.: +38 (044) 545-64-40

E-mail: ua@dlink.ua

Moldova

Chisinau; str.C.Negruzzi-8

Tel: +373 (22) 80-81-07

E-mail: info@dlink.md

Беларусь

Мінск, пр-т Незалежнасці, 169

Тэл.: +375 (17) 218-13-65

E-mail: support@dlink.by

Қазақстан

Алматы, Құрманғазы к-сі, 143 үй

Тел.: +7 (727) 378-55-90

E-mail: almaty@dlink.ru

Հայաստան

Երևան, Դավթաշեն 3-րդ

թաղամաս, 23/5

Հեռ.՝ +374 (10) 39-86-67

Էլ. փոստ՝ info@dlink.am

Latvija

Rīga, Lielirbes iela 27

Tel.: +371 (6) 761-87-03

E-mail: info@dlink.lv

Lietuva

Vilnius, Žirmūnu 139-303

Tel.: +370 (5) 236-36-29

E-mail: info@dlink.lt

Eesti

E-mail: info@dlink.ee

Türkiye

Uphill Towers Residence A/99

Ataşehir /ISTANBUL

Tel: +90 (216) 492-99-99

Email: info.tr@dlink.com.tr

ישראל

20 רח' המגשימים

קרית מטלון

פתח תקווה

072-2575555

support@dlink.co.il

Soporte Técnico Para Usuarios En Latino America

Por favor revise el número telefónico del Call Center de su país en <http://www.dlinkla.com/soporte/call-center>

Soporte Técnico de D-Link a través de Internet

Horario de atención Soporte Técnico en www.dlinkla.com
e-mail: soporte@dlinkla.com & consultas@dlinkla.com

Clientes de Brasil

Caso tenha dúvidas na instalação do produto, entre em contato com o Suporte Técnico D-Link.

Acesse o site: **www.dlink.com.br/suporte**

D-Link 友訊科技 台灣分公司 技術支援資訊

如果您還有任何本使用手冊無法協助您解決的產品相關問題，台灣、香港或是澳門用戶可至網站、電子郵件或電話等方式與D-Link技術支援工程師聯絡。

台灣D-Link免付費技術諮詢專線

台灣技術諮詢服務專線 0800-002-615

台灣手機付費電話 (02) 6600-0123#8715

台灣網站：<http://www.dlink.com.tw>

台灣電子郵件：dssqa_service@dlink.com.tw

產品保固期限、台灣區技術諮詢時間、維修據點查詢，請參考<http://www.dlink.com.tw> 網頁說明

香港、澳門D-Link技術諮詢專線

香港技術諮詢服務專線 (852) 8100 8892

香港服務時間：週一至週五 10:00 ~ 13:00及14:00 ~ 18:00

週六 09:00 ~ 13:00 / 週日及公眾假期休息

香港網站：<http://www.dlink.com.hk>

香港電子郵件：service@cn.synnex-grp.com

香港、澳門維修據點查詢請參考<http://www.dlink.com.hk/contact.html> 網頁說明。

如果您在其他地區的用戶，請參考D-Link網站www.dlink.com 查詢全球各地分公司的聯絡資訊以取得相關支援服務。



立即掃描QR code

了解更多
服務資訊

Pelanggan Indonesia

Update perangkat lunak dan dokumentasi pengguna dapat diperoleh pada situs web D-Link.

Dukungan Teknis untuk pelanggan:

Tel: 0800-14014-97 (Layanan Bebas Pulsa)

Dukungan Teknis D-Link melalui Internet:

Pertanyaan Umum: sales@id.dlink.com

Bantuan Teknis: support@id.dlink.com

Website : <http://www.dlink.co.id>

日本のお客様

この度は弊社製品をお買い上げいただき、誠にありがとうございます。

製品に同梱されている保証書の購入元にお問い合わせください。

中国客户

技术支持中心电话：

400-629-6688(家用产品热线) 4006-828-828(企业产品热线)

技术支持中心邮箱：dlink400@cn.dlink.com

各地维修中心地址请登录官方网站查询

网址：<http://www.dlink.com.cn>

400电话工作时间：工作日9:00-19:00；节假日9:00-18:00

Registration Card

All Countries and Regions Excluding USA

Print, type or use block letters.

Your name: Mr./Ms _____

Organization: _____ Dept. _____

Your title at organization: _____

Telephone: _____ Fax: _____

Organization's full address: _____

Country: _____

Date of purchase (Month/Day/Year): _____

Product Model	Product Serial No.	* Product installed in type of computer	* Product installed in computer serial No.

(* Applies to adapters only)

Product was purchased from:

Reseller's name: _____

Telephone: _____

Answers to the following questions help us to support your product:

1. Where and how will the product primarily be used?

Home Office Travel Company Business Home Business Personal Use

2. How many employees work at installation site?

1 employee 2-9 10-49 50-99 100-499 500-999 1000 or more

3. What network protocol(s) does your organization use ?

XNS/IPX TCP/IP DECnet Others _____

4. What network operating system(s) does your organization use ?

D-Link LANsmart Novell NetWare NetWare Lite SCO Unix/Xenix PC NFS 3Com 3+Open Cisco Network
Banyan Vines DECnet Pathwork Windows NT Windows 98 Windows 2000/ME Windows XP
Others _____

5. What network management program does your organization use ?

D-View HP OpenView/Windows HP OpenView/Unix SunNet Manager Novell NMS
NetView 6000 Others _____

6. What network medium/media does your organization use ?

Fiber-optics Thick coax Ethernet Thin coax Ethernet 10BASE-T UTP/STP
100BASE-TX 1000BASE-T Wireless 802.11b and 802.11g wireless 802.11a Others _____

7. What applications are used on your network?

Desktop publishing Spreadsheet Word processing CAD/CAM
Database management Accounting Others _____

8. What category best describes your company?

Aerospace Engineering Education Finance Hospital Legal Insurance/Real Estate Manufacturing
Retail/Chain store/Wholesale Government Transportation/Utilities/Communication VAR
System house/company Other _____

9. Would you recommend your D-Link product to a friend?

Yes No Don't know yet

10. Your comments on this product?

PLEASE
PLACE STAMP
HERE

TO:

D-Link®