



Quick Installation Guide Industrial Ethernet Switch

This document will guide you through the basic installation process for your new D-Link Industrial Ethernet Switch.

DIS-200G Series



Quick Installation Guide

Documentation is also available
on the D-Link website

Before You Begin

This Quick Installation Guide gives you step-by-step instructions for setting up the DIS-200G Series Layer 2 Gigabit Industrial Smart Managed Switch. The model you have purchased may appear slightly different from the one shown in the illustrations. For more detailed information about the switch, please refer to the user manual.

Package Contents

This package should include the following items:

- DIS-200G Series switch
- DIN rail mounting kit
- Wall mounting kit
- User guide CD
- Quick Installation Guide
- Console cable

If any of the above items are damaged or missing, please contact your local D-Link reseller.

Hardware Overview

LED Indicators

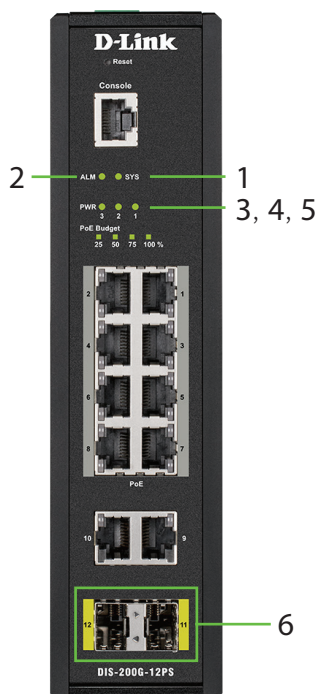

Figure 1

#	LED	Status	Description
1	SYS	Solid green	The DIS-200G is on and accepting web connections.
		Blinking green	A firmware update is in progress.
		Solid amber	The DIS-200G is not ready for communication.
		Blinking amber	The DIS-200G is booting up or PoE has failed during system operation (DIS-200G-12PS/PSW models only).
2	ALM	Solid amber	The power supply to the DIS-200G has failed.
3	PWR 1	Solid green	Power source 1 is connected.
4	PWR 2	Solid green	Power source 2 is connected.
5	PWR 3	Solid green	Power source 3 is connected.
6	Ports 11 - 12	Solid green	Port is connected at 1 Gbps.
		Blinking green	There is activity on the port at 1 Gbps.

Table 1

DIS-200G-12PS/PSW

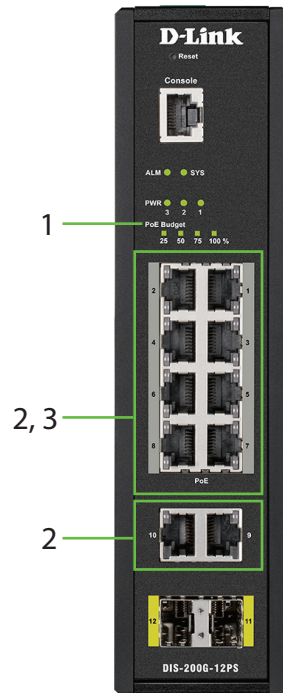

Figure 2

All Switches

#	LED	Status	Description
1	PoE Budget 100	Solid green	The power budget is 100% and no PoE is being used.
	PoE Budget 75	Solid green	The power budget is between 100 and 75%.
	PoE Budget 50	Solid green	The power budget is between 75 and 50%.
	PoE Budget 25	Solid green	The power budget is between 50 and 25%.
Solid amber		The power budget is between 25 and 0%, but still has more than 15.4 W remaining.	
Blinking amber		The power budget is between 25 and 0% and has less than 15.4 W remaining.	
2	Left: Ports 1 - 10	Solid green	Port is connected at 1 Gbps.
		Blinking green	There is activity on the port at 1 Gbps.
		Solid amber	Port is connected at 10/100 Mbps.
		Blinking amber	There is activity on the port at 10/100 Mbps.
3	Right: Ports 1 - 8	Solid green	The PoE output is using IEEE 802.3af/at and is less than 15.4 W.
		Solid amber	The PoE output is using IEEE 802.3at and is between 15.4 and 30 W.
		Blinking amber	The PoE output on the port is over 30 W and the port has been shut down.

Table 2

DIS-200G-12S/SW

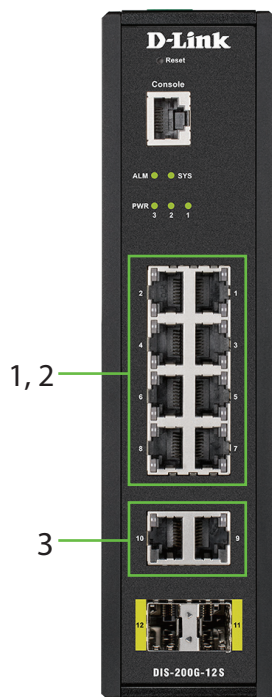

Figure 3

#	LED	Status	Description
1	Left: Ports 1 - 8	Solid green	Port is connected at 1 Gbps.
		Blinking green	The port is undergoing cable diagnostics.
		Solid amber	Port is connected at 10/100 Mbps.
2	Right: Ports 1 - 8	Blinking green	There is activity on the port at 1 Gbps.
		Blinking amber	There is activity on the port at 10/100 Mbps.
3	Left: Ports 9 - 10	Solid green	Port is connected at 1 Gbps.
		Blinking green	There is activity on the port at 1 Gbps.
		Solid amber	Port is connected at 10/100 Mbps.
		Blinking amber	There is activity on the port at 10/100 Mbps.

Table 3

Front Panel Connectors

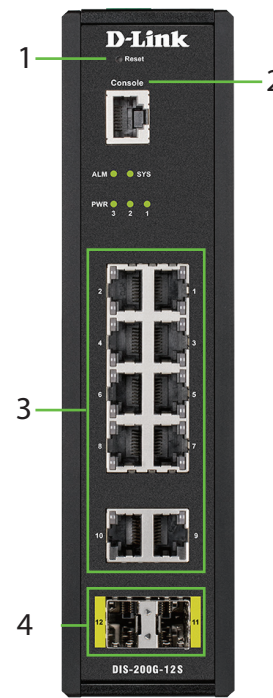

Figure 4

#	Item	Description
1	Reset	This is the reset button which is used to perform a factory reset.
2	Console	This is a console port which is used to connect to the DIS-200G using a RJ-45 to serial cable.
3	Ports 1 to 10	These are 10/100/1000 Mbps ports that can be used to connect to any device using a standard Category 5/5e RJ-45 Ethernet cable.
4	Ports 11 to 12	These are 1 Gbps SFP ports that can be used to connect to other switches using compatible SFP adapters and fiber cable.

Table 4

Rear Panel Connectors



Figure 5

#	Item	Description
1	Power input	This is used to connect an external power adapter to the switch.

Table 5

Top Panel Connectors

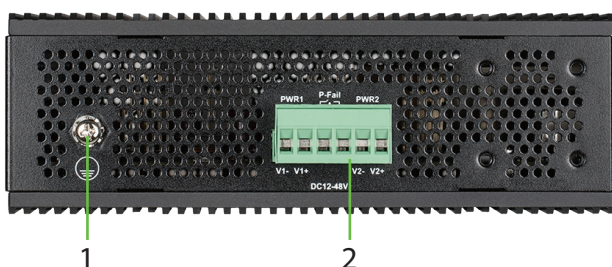

Figure 6

#	Item	Description
1	Switch ground	This is used to connect the switch to ground.
2	Terminal block	This is used to connect the switch to external power sources and relays.

Table 6

Hardware Installation

Before You Begin

Observe the following precautions to help prevent shutdowns, equipment failures, and personal injury:

- Install the DIS-200G in a cool and dry place. Refer to the technical specifications in the user manual for the acceptable operating temperature and humidity ranges.
- Leave at least 10 cm of space at the top, rear and bottom of the switch for ventilation.
- Visually inspect the power connector and make sure that it is fully secured to the power cord.
- Do not stack any devices on top of the switch.

It is also recommended that power and grounding

requirements are investigated before mounting the DIS-200G, as access to the switch may be restricted once it has been installed.

Mounting the Switch on a DIN Rail

Before beginning either mounting or removing the DIS-200G from a DIN rail, please ensure that the DIN rail is level and that the DIN rail mounting kit is installed correctly on the DIS-200G.

Use the following instructions to install the DIS-200G on a DIN rail:

1. With the back of the DIS-200G facing the DIN rail, lower the top part of the rail mounting kit onto the DIN rail.
2. Push the DIS-200G vertically down and rotate the bottom of the DIS-200G towards the DIN rail, to attach the switch to the DIN rail.

Use the following instructions to remove the DIS-200G from a DIN rail:

1. Push the DIS-200G vertically down to create enough space at the bottom of the rail mounting kit to remove the DIS-200G from the DIN rail.
2. Rotate the DIS-200G upwards to remove the bottom of the rail mounting kit from the rail, and lift the DIS-200G upwards to remove the whole of the switch from the DIN rail.

Mounting the Switch on a Wall

The DIS-200G can be installed on a solid surface by using the included wall mounting plates attached to the back of the switch. It can also be mounted using the in-built screw hooks on the underneath of the switch.

Using the Wall Mounting Brackets

Use the following instructions to install the DIS-200G on a wall:

1. Remove the DIN rail mounting kit from the back of the DIS-200G (if present).
2. Align the cross-section of the mounting plates with the openings on the back of the switch and secure the plates to the switch with the included screws.
3. Place the switch with the mounting brackets installed on the location where you want to mount it, and use the mounting brackets as a guide to mark where to drill the screw holes.
4. Drill holes on the marks and insert wall anchors appropriate for the material of the wall.

- Align the switch with the wall anchors and secure the switch to the wall using the appropriate screws for the wall anchors.

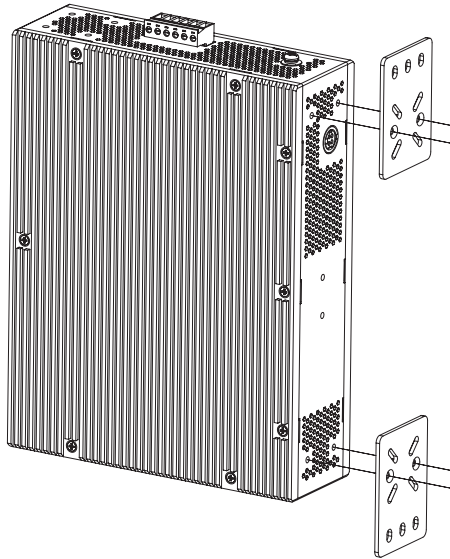

Figure 7

Using the Screw Hooks

Use the following instructions to mount the DIS-200G on a wall using the screw hooks on the underneath of the switch:

- Mark two points on the surface where you wish to mount the switch 60 mm apart.
- Drill holes on the marks and insert wall anchors appropriate for the material of the wall.
- Insert screws into the wall anchors, leaving roughly 4.50 mm of distance from the wall for the switch to be mounted.
- Mount the DIS-200G on the screws using the screw hooks on the underneath of the switch.

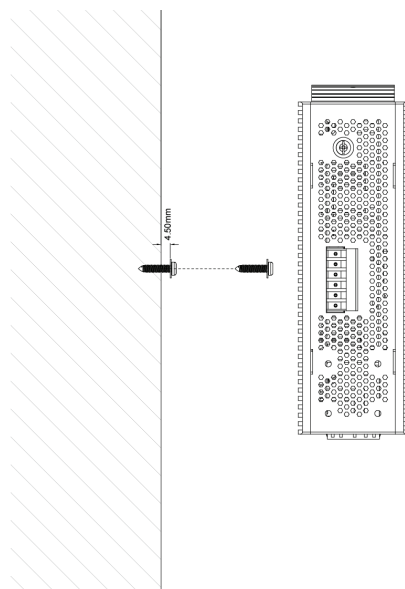

Figure 8

Mounting the Switch in a Rack

The DIS-200G can be mounted in a standard 19" server rack by using the included rack mounting brackets (optional).

Use the following instructions to install the switch in a rack:

- Attach the included mounting brackets to each side of the DIS-200G using the provided screws.

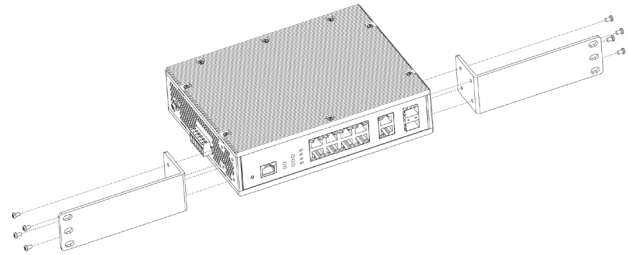

Figure 9

- Use the screws that were provided with the rack to install the DIS-200G in the rack.

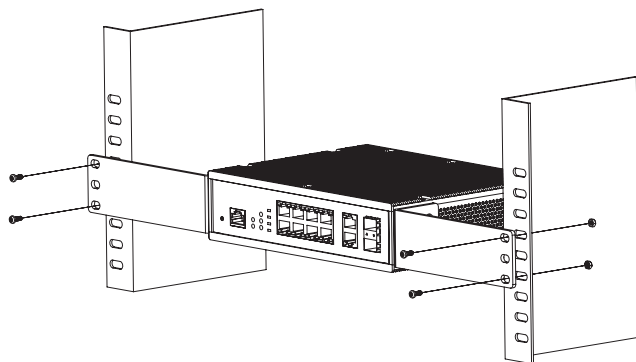

Figure 10

Grounding the Switch

To use the DIS-200G safely, it needs to be grounded. Please complete these steps before powering-on the switch.

Use the following instructions to ground the DIS-200G:

- Remove the grounding screw from the top of the DIS-200G and place the grounding cable lug ring on top of the grounding screw opening.
- Insert the grounding screw back into the grounding screw opening and use a screwdriver to tighten the grounding screw, securing the grounding cable to the DIS-200G.
- Attach the terminal lug ring at the other end of the grounding cable to an appropriate grounding source.

4. Verify that the connection between the grounding connector on the DIS-200G and the grounding source is secure.

Connecting to a Power Source

The DIS-200G can be powered using a power adapter (optional) or by using the in-built terminal connector. This allows dual power inputs, using wires from the power source(s) screwed-in to the terminal connections.

Using the Power Adapter (Optional)

Use the following instructions to power the DIS-200G using the power adapter (optional):

1. Connect the supplied power adapter to the power connector on the back of the DIS-200G. Connect the other end of the power adapter to a mains power source.

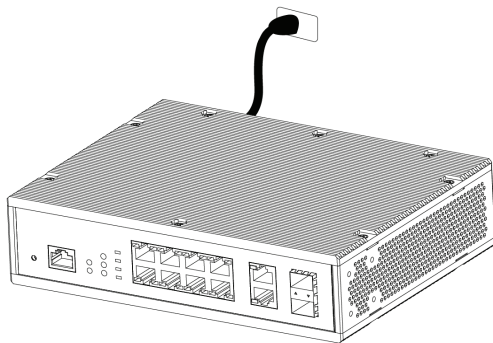

Figure 11

Using the Terminal Connections

Before proceeding, ensure that all power sources have been disconnected from the DIS-200G, and that the power source you are wiring to the DIS-200G is also disconnected.

Use the following instructions to power the DIS-200G using the terminal connections:

1. Before continuing, consult the diagram below to decide which wires from the power source need to connect to which contacts on the terminal block. Note that two power sources can be used; one inserted into V1-/V1+ (labeled PWR1) and the other inserted into V2-/V2+ (labeled PWR2). If you only wish to use one power source, insert the wires into V1-/V1+ (PWR1). This diagram is also provided on the DIS-200G:

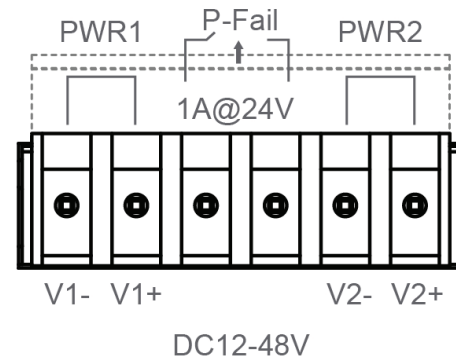

Figure 12

2. Use a lever to remove the terminal block from the switch.

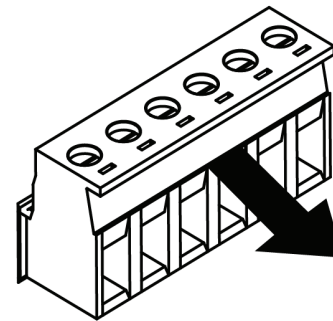

Figure 13

3. Using a flat head screwdriver, loosen the connections in the terminal block by un-screwing the terminal connections that you wish to use.
4. Insert the wires into the terminal connections and use the screwdriver to tighten the screws to secure the wires.

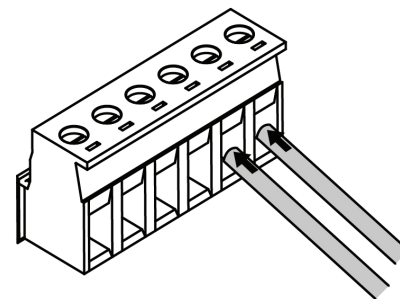

Figure 14

5. Re-insert the terminal block into the terminal block socket on the DIS-200G.

Management Options

The DIS-200G can be managed by using the Web User Interface (Web UI), D-Link Network Assistant (DNA), console port, Telnet, or Simple Network Management Protocol (SNMP) management interfaces.

If you wish to manage a single D-Link switch, the

Web UI may be the best option. Each switch must be assigned its own IP address, which is used for communication with the management PC. However, if you wish to manage multiple D-Link switches, DNA may be the best option. You do not need to change the IP address of your PC and it makes the initial set up of multiple switches easy.

Please refer to the following installation instructions to get started with the Web UI, DNA, console port, Telnet, and SNMP management interfaces.

Web User Interface

Once the switch has been successfully installed, you can begin configuration, monitor the LED panel, and display graphical statistics using a web browser. Supported browsers include: Microsoft® Internet Explorer, Firefox, Chrome, and Safari.

You need the following equipment to access the Web UI of your device:

- A PC with an RJ-45 Ethernet connection
 - A standard Ethernet cable
1. Connect the Ethernet cable to any of the ports on the switch's front panel and to the Ethernet port on the PC.
 2. Configure the PC's IP address to be in the same network segment as the switch. The switch's default IP address is 10.90.90.90, with subnet mask 255.0.0.0. For example, to connect to the switch using the default settings, your PC should have an IP address in the range: 10.0-255.0-255.0-254 and a subnet mask of 255.0.0.0.
 3. Open a web browser and enter **http://10.90.90.90/** in the address box. **Note:** The Web UI can also be accessed through DNA, by clicking the switch's IP in the device list.
 4. Log in to the switch. To do this, enter **admin** as the default user name and password and click OK.

D-Link Network Assistant (depending on the purchased model)

D-Link Network Assistant (DNA) is a program that is used to discover switches which are in the same Layer 2 network segment as your PC. You can download the DNA APP from <http://tools.dlink.com/intro/dna/>.

1. Select "Free Download" button to download the DNA APP
2. Click 'ADDTO CHROME' button on the right hand side of the search results.
3. Click 'Add app' button in the pop up window to install the D-Link Network Assistant in Chrome.
4. When the installation process completes: (Option 1) Click the 'LAUNCH APP' button in the upper-right corner of the window to start DNA.



(Option 2) Click the 'Apps' icon in the upper-left corner of the Chrome browser and click 'DNA' in the Apps list to start DNA.



Note: for managed switches, users need to enable D-Link Discovery Protocol (DDP) and create a user name and password to be able to log in to DNA.

Console

To connect to the switch's console, use the supplied cable to connect to the switch's console port. This cable is a RS-232 serial to RJ-45 connector cable designed for use with the switch. A terminal emulation program is required to connect to the console port on the switch. These are widely available and can be easily downloaded from the Internet.

Using following steps to connect to switch's console port:

1. Connect the RS-232 serial interface to the serial port of the management PC.
2. Connect the RJ-45 interface to the console port of the switch.
3. Open a terminal emulation program on the management PC and configure the properties of the connection as follows:
 - The speed should be 115200 baud.
 - The data bits should be 8.
 - The parity should be None.
 - The stop bits should be 1.
 - The flow control should be None.
4. Connect to the switch and the Command Line Interface (CLI) should be available. When

prompted to log in, enter **admin** as the default user name and password.

Telnet

To connect to the switch using Telnet, a Telnet client is required. This may be included with your operating system, or can be easily downloaded from the Internet.

Before connecting to the switch, ensure that your PC has an IP address in the same range as the switch. Follow the instructions in the Web User Interface section for more information on how to do this.

1. Launch the Telnet software and connect to the IP address of the switch.
2. When you are prompted for a username and password, enter **admin** as the default user name and password.

SNMP

You can manage the switch with D-Link D-View, or any other SNMP-compatible program. The SNMP function is disabled by default and must be enabled on the switch first by using either the Web UI, DNA, the console, or Telnet.

D-View SNMP Network Management System is a comprehensive standard-based management tool designed to centrally manage critical network infrastructure. D-View provides useful tools to allow network administrators to effectively manage device configurations, fault tolerance, performance, and security.

D-Link offers a free version of D-View which can be used to manage up to 25 devices. Visit <http://dview.dlink.com/> to download it and get more information.

Device Reset

If you have any problems accessing the DIS-200G, it can be reset using the following instructions:

1. Press and hold the reset button for 6 to 10 seconds. All the LEDs on the DIS-200G will light amber. When this happens, release the reset

button and the DIS-200G will be reset to factory defaults.

Note: holding the reset button for more than 11 seconds will cause all LEDs on the DIS-200G to light green. Holding the reset button for a further 2 seconds will put the DIS-200G into boot loader mode.

Additional Information

You can refer to the user manual or visit <http://support.dlink.com/> for more support.

- **D-Link Managed Switch User Manual**

This manual describes the general installation and how to connect the switch in various scenarios.

Online Support

If there are any issues that are not in the user manual, please visit <http://support.dlink.com/> which will direct you to your appropriate local D-Link support website.

Warranty Information

Visit <http://warranty.dlink.com/> to view the D-Link Limited Lifetime Warranty information.

Regulatory Statements

Federal Communication Commission Interference Statement

This equipment has been tested and found to comply with the limits for a Class A digital device, pursuant to part 15 of the FCC Rules. These limits are designed to provide reasonable protection against harmful interference when the equipment is operated in a commercial environment. This equipment generates, uses, and can radiate radio frequency energy and, if not installed and used in accordance with the instruction manual, may cause harmful interference to radio communications. Operation of this equipment in a residential area is likely to cause harmful interference in which case the user will be required to correct the interference at his own expense.

Non-modification Statement

Any changes or modifications not expressly approved by the party responsible for compliance could void the user's authority to operate the equipment.

Caution

This device complies with Part 15 of the FCC Rules. Operation is subject to the following two conditions:

(1) This device may not cause harmful interference, and (2) this device must accept any interference received, including interference that may cause undesired operation.

Industry Canada Statement:

This Class A digital apparatus complies with Canadian ICES-003.
Cet appareil numérique de la classe A est conforme à la norme NMB-003 du Canada.

Japan Voluntary Control Council for Interference Statement

この装置は、クラス A 情報技術装置です。この装置を家庭環境で使用すると電波妨害を引き起こすことがあります。この場合には使用者が適切な対策を講ずるよう要求されることがあります。

VCCI-A

警告使用者:

此為甲類的資訊技術設備，在居住環境中使用時，可能會造成射頻擾動，在這種情況下，使用者會被要求採取某些適當的對策。

Warning: This is a class A product. In a domestic environment this product may cause radio interference in which case the user may be required to take adequate measures.

CE EMI Class A Warning

This equipment is compliant with Class A of CISPR 32. In a residential environment this equipment may cause radio interference.

SAFETY INSTRUCTIONS

The following general safety guidelines are provided to help ensure your own personal safety and protect your product from potential damage. Remember to consult the product user instructions for more details.

- Static electricity can be harmful to electronic components. Discharge static electricity from your body (i.e. touching grounded bare metal) before touching the product.
- Do not attempt to service the product and never disassemble the product. For some products with user replaceable battery, please read and follow the instructions in the user manual.
- Do not spill food or liquid on your product and never push any objects into the openings of your product.
- Do not use this product near water, areas with high humidity or condensation unless the product is specifically rated for outdoor application.
- Keep the product away from radiators and other heat sources.
- Always unplug the product from mains power before cleaning and use a dry lint free cloth only

Sicherheitsinstruktion

Die folgenden allgemeinen Sicherheitsinstruktionen dienen als Hilfe zur Gewährleistung Ihrer eigenen Sicherheit und zum Schutz Ihres Produkts. Weitere Details finden Sie in den Benutzeranleitungen zum Produkt.

- Statische Elektrizität kann elektronischen Komponenten schaden. Um Schäden durch statische Aufladung zu vermeiden, leiten Sie elektrostatische Ladungen von Ihrem Körper ab, (z. B. durch Berühren eines geerdeten blanken Metallteils), bevor Sie das Produkt berühren.
- Unterlassen Sie jeden Versuch, das Produkt zu warten, und versuchen Sie nicht, es in seine Bestandteile zu zerlegen. Für einige Produkte mit austauschbaren Akkus lesen Sie bitte das Benutzerhandbuch und befolgen Sie die dort beschriebenen Anleitungen.
- Vermeiden Sie, dass Speisen oder Flüssigkeiten auf Ihr Produkt gelangen, und stecken Sie keine Gegenstände in die Gehäuseschlitze oder -öffnungen Ihres Produkts.
- Verwenden Sie dieses Produkt nicht in unmittelbarer Nähe von Wasser und nicht in Bereichen mit hoher Luftfeuchtigkeit oder Kondensation, es sei denn, es ist speziell zur

Nutzung in Außenbereichen vorgesehen und eingestuft.

- Halten Sie das Produkt von Wärmequellen entfernt wie z.B. Heizkörper.
- Trennen Sie das Produkt immer von der Stromzufuhr, bevor Sie es reinigen und verwenden Sie dazu ausschließlich ein trockenes fusselfreies Tuch.

Consignes de sécurité

Les consignes générales de sécurité ci-après sont fournies afin d'assurer votre sécurité personnelle et de protéger le produit d'éventuels dommages. Veuillez consulter les consignes d'utilisation du produit pour plus de détails.

- L'électricité statique peut endommager les composants électroniques. Déchargez l'électricité statique de votre corps (en touchant un objet en métal relié à la terre par exemple) avant de toucher le produit.
- N'essayez pas d'intervenir sur le produit et ne le démontez jamais. Pour certains produits contenant une batterie remplaçable par l'utilisateur, veuillez lire et suivre les consignes contenues dans le manuel d'utilisation.
- Ne renversez pas d'aliments ou de liquide sur le produit et n'insérez jamais d'objets dans les orifices.
- N'utilisez pas ce produit à proximité d'un point d'eau, de zones très humides ou de condensation sauf si le produit a été spécifiquement conçu pour une application extérieure.
- Éloignez le produit des radiateurs et autres sources de chaleur.
- Débranchez toujours le produit de l'alimentation avant de le nettoyer et utilisez uniquement un chiffon sec non pelucheux.

Instrucciones de seguridad

Las siguientes directrices de seguridad general se facilitan para ayudarle a garantizar su propia seguridad personal y para proteger el producto frente a posibles daños. No olvide consultar las instrucciones del usuario del producto para obtener más información.

- La electricidad estática puede resultar nociva para los componentes electrónicos. Descargue la electricidad estática de su cuerpo (p. ej., tocando algún metal sin revestimiento conectado a tierra) antes de tocar el producto.
- No intente realizar el mantenimiento del producto

- ni lo desmonte nunca. Para algunos productos con batería reemplazable por el usuario, lea y siga las instrucciones del manual de usuario.
- No derrame comida o líquidos sobre el producto y nunca deje que caigan objetos en las aberturas del mismo.
 - No utilice este producto cerca del agua, en zonas con humedad o condensación elevadas a menos que el producto esté clasificado específicamente para aplicación en exteriores.
 - Mantenga el producto alejado de los radiadores y de otras fuentes de calor.
 - Desenchufe siempre el producto de la alimentación de red antes de limpiarlo y utilice solo un paño seco sin pelusa

Istruzioni per la sicurezza

Le seguenti linee guida sulla sicurezza sono fornite per contribuire a garantire la sicurezza personale degli utenti e a proteggere il prodotto da potenziali danni. Per maggiori dettagli, consultare le istruzioni per l'utente del prodotto.

- L'elettricità statica può essere pericolosa per i componenti elettronici. Scaricare l'elettricità statica dal corpo (ad esempio toccando una parte metallica collegata a terra) prima di toccare il prodotto.
- Non cercare di riparare il prodotto e non smontarlo mai. Per alcuni prodotti dotati di batteria sostituibile dall'utente, leggere e seguire le istruzioni riportate nel manuale dell'utente.
- Non versare cibi o liquidi sul prodotto e non spingere mai alcun oggetto nelle aperture del prodotto.
- Non usare questo prodotto vicino all'acqua, in aree con elevato grado di umidità o soggette a condensa a meno che il prodotto non sia specificatamente approvato per uso in ambienti esterni.
- Tenere il prodotto lontano da caloriferi e altre fonti di calore.
- Scollegare sempre il prodotto dalla presa elettrica prima di pulirlo e usare solo un panno asciutto che non lasci filacce.

Veiligheidsinformatie

De volgende algemene veiligheidsinformatie werd verstrekt om uw eigen persoonlijke veiligheid te waarborgen en uw product te beschermen tegen mogelijke schade. Denk eraan om de

gebruikersinstructies van het product te raadplegen voor meer informatie.

- Statische elektriciteit kan schadelijk zijn voor elektronische componenten. Ontlaad de statische elektriciteit van uw lichaam (d.w.z. het aanraken van geaard bloot metaal) voordat u het product aanraakt.
- U mag nooit proberen het product te onderhouden en u mag het product nooit demonteren. Voor sommige producten met door de gebruiker te vervangen batterij, dient u de instructies in de gebruikershandleiding te lezen en te volgen.
- Mors geen voedsel of vloeistof op uw product en u mag nooit voorwerpen in de openingen van uw product duwen.
- Gebruik dit product niet in de buurt van water, gebieden met hoge vochtigheid of condensatie, tenzij het product specifiek geclassificeerd is voor gebruik buitenshuis.
- Houd het product uit de buurt van radiators en andere warmtebronnen.
- U dient het product steeds los te koppelen van de stroom voordat u het reinigt en gebruik uitsluitend een droge pluisvrije doek

Disposing of and Recycling Your Product

ENGLISH

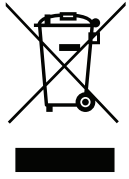

This symbol on the product or packaging means that according to local laws and regulations this product should be not be disposed of in household waste but sent for recycling. Please take it to a collection point designated by your local authorities once it has reached the end of its life, some will accept products for free. By recycling the product and its packaging in this manner you help to conserve the environment and protect human health.

D-Link and the Environment

At D-Link, we understand and are committed to reducing any impact our operations and products may have on the environment. To minimise this impact D-Link designs and builds its products to be as environmentally friendly as possible, by using recyclable, low toxic materials in both products and packaging.

D-Link recommends that you always switch off or unplug your D-Link products when they are not in use. By doing so you will help to save energy and reduce CO2 emissions.

To learn more about our environmentally responsible products and packaging please visit www.dlinkgreen.com.

DEUTSCH

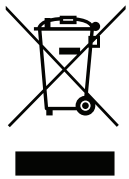

Dieses Symbol auf dem Produkt oder der Verpackung weist darauf hin, dass dieses Produkt gemäß bestehender örtlicher Gesetze und Vorschriften nicht über den normalen Hausmüll entsorgt werden sollte, sondern einer Wiederverwertung zuzuführen ist. Bringen Sie es bitte zu einer von Ihrer Kommunalbehörde entsprechend amtlich ausgewiesenen Sammelstelle, sobald das Produkt das Ende seiner Nutzungsdauer erreicht hat. Für die Annahme solcher Produkte erheben einige dieser Stellen keine Gebühren. Durch ein auf diese Weise durchgeführtes Recycling des Produkts und seiner Verpackung helfen Sie, die Umwelt zu schonen und die menschliche Gesundheit zu schützen.

D-Link und die Umwelt

D-Link ist sich den möglichen Auswirkungen seiner Geschäftstätigkeiten und seiner Produkte auf die Umwelt bewusst und fühlt sich verpflichtet, diese entsprechend zu mindern. Zu diesem Zweck entwickelt und stellt D-Link seine Produkte mit dem Ziel größtmöglicher Umweltfreundlichkeit her und verwendet wiederverwertbare, schadstoffarme Materialien bei Produktherstellung und Verpackung.

D-Link empfiehlt, Ihre Produkte von D-Link, wenn nicht in Gebrauch, immer auszuschalten oder vom Netz zu nehmen. Auf diese Weise helfen Sie, Energie zu sparen und CO2-Emissionen zu reduzieren.

Wenn Sie mehr über unsere umweltgerechten Produkte und Verpackungen wissen möchten, finden Sie entsprechende Informationen im Internet unter www.dlinkgreen.com.

EN

FRANÇAIS



Ce symbole apposé sur le produit ou son emballage signifie que, conformément aux lois et réglementations locales, ce produit ne doit pas être éliminé avec les déchets domestiques mais recyclé. Veuillez le rapporter à un point de collecte prévu à cet effet par les autorités locales; certains accepteront vos produits gratuitement. En recyclant le produit et son emballage de cette manière, vous aidez à préserver l'environnement et à protéger la santé de l'homme.

D-Link et l'environnement

Chez D-Link, nous sommes conscients de l'impact de nos opérations et produits sur l'environnement et nous engageons à le réduire. Pour limiter cet impact, D-Link conçoit et fabrique ses produits de manière aussi écologique que possible, en utilisant des matériaux recyclables et faiblement toxiques, tant dans ses produits que ses emballages.

D-Link recommande de toujours éteindre ou débrancher vos produits D-Link lorsque vous ne les utilisez pas. Vous réaliserez ainsi des économies d'énergie et réduirez vos émissions de CO2.

Pour en savoir plus sur les produits et emballages respectueux de l'environnement, veuillez consulter le www.dlinkgreen.com.

FR

ESPAÑOL

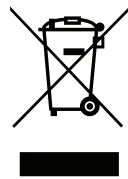

Este símbolo en el producto o el embalaje significa que, de acuerdo con la legislación y la normativa local, este producto no se debe desechar en la basura doméstica sino que se debe reciclar. Llévelo a un punto de recogida designado por las autoridades locales una vez que ha llegado al fin de su vida útil; algunos de ellos aceptan recogerlos de forma gratuita. Al reciclar el producto y su embalaje de esta forma, contribuye a preservar el medio ambiente y a proteger la salud de los seres humanos.

D-Link y el medio ambiente

En D-Link, comprendemos y estamos comprometidos con la reducción del impacto que puedan tener nuestras actividades y nuestros productos en el medio ambiente. Para reducir este impacto, D-Link diseña y fabrica sus productos para que sean lo más ecológicos posible, utilizando materiales reciclables y de baja toxicidad tanto en los productos como en el embalaje.

D-Link recomienda apagar o desenchufar los productos D-Link cuando no se estén utilizando. Al hacerlo, contribuirá a ahorrar energía y a reducir las emisiones de CO2.

Para obtener más información acerca de nuestros productos y embalajes ecológicos, visite el sitio www.dlinkgreen.com.

ES

ITALIANO



La presenza di questo simbolo sul prodotto o sulla confezione del prodotto indica che, in conformità alle leggi e alle normative locali, questo prodotto non deve essere smaltito nei rifiuti domestici, ma avviato al riciclo. Una volta terminato il ciclo di vita utile, portare il prodotto presso un punto di raccolta indicato dalle autorità locali. Alcuni questi punti di raccolta accettano gratuitamente i prodotti da riciclare. Scegliendo di riciclare il prodotto e il relativo imballaggio, si contribuirà a preservare l'ambiente e a salvaguardare la salute umana.

D-Link e l'ambiente

D-Link cerca da sempre di ridurre l'impatto ambientale dei propri stabilimenti e dei propri prodotti. Allo scopo di ridurre al minimo tale impatto, D-Link progetta e realizza i propri prodotti in modo che rispettino il più possibile l'ambiente, utilizzando materiali riciclabili a basso tasso di tossicità sia per i prodotti che per gli imballaggi.

D-Link raccomanda di spegnere sempre i prodotti D-Link o di scollegarne la spina quando non vengono utilizzati. In questo modo si contribuirà a risparmiare energia e a ridurre le emissioni di anidride carbonica.

Per ulteriori informazioni sui prodotti e sugli imballaggi D-Link a ridotto impatto ambientale, visitate il sito all'indirizzo www.dlinkgreen.com.

NEDERLANDS



Dit symbool op het product of de verpakking betekent dat dit product volgens de plaatselijke wetgeving niet mag worden weggegooid met het huishoudelijk afval, maar voor recycling moeten worden ingeleverd. Zodra het product het einde van de levensduur heeft bereikt, dient u het naar een inzamelpunt te brengen dat hiertoe werd aangeduid door uw plaatselijke autoriteiten, sommige autoriteiten accepteren producten zonder dat u hiervoor dient te betalen. Door het product en de verpakking op deze manier te recyclen helpt u het milieu en de gezondheid van de mens te beschermen.

D-Link en het milieu

Bij D-Link spannen we ons in om de impact van onze handelingen en producten op het milieu te beperken. Om deze impact te beperken, ontwerpt en bouwt D-Link zijn producten zo milieuvriendelijk mogelijk, door het gebruik van recycleerbare producten met lage toxiciteit in product en verpakking.

D-Link raadt aan om steeds uw D-Link producten uit te schakelen of uit de stekker te halen wanneer u ze niet gebruikt. Door dit te doen bespaart u energie en beperkt u de CO₂-emissies.

Breng een bezoek aan www.dlinkgreen.com voor meer informatie over onze milieuverantwoorde producten en verpakkingen.

IT

POLSKI

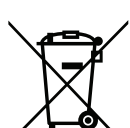

Ten symbol umieszczony na produkcie lub opakowaniu oznacza, że zgodnie z miejscowym prawem i lokalnymi przepisami niniejszego produktu nie wolno wyrzucać jak odpady czy śmieci z gospodarstwa domowego, lecz należy go poddać procesowi recyklingu. Po zakończeniu użytkowania produktu, niektóre odpowiednie do tego celu podmioty przyjmą takie produkty nieodpłatnie, dlatego prosimy dostarczyć go do punktu zbiórki wskazanego przez lokalne władze. Poprzez proces recyklingu i dzięki takiemu postępowaniu z produktem oraz jego opakowaniem, pomogą Państwo chronić środowisko naturalne i dbać o ludzkie zdrowie.

D-Link i środowisko

D-Link podchodzimy w sposób świadomy do ochrony otoczenia oraz jesteśmy zaangażowani w zmniejszanie wpływu naszych działań i produktów na środowisko naturalne. W celu zminimalizowania takiego wpływu firma D-Link konstruuje i wytwarza swoje produkty w taki sposób, aby były one jak najbardziej przyjazne środowisku, stosując do tych celów materiały nadające się do powtórnego wykorzystania, charakteryzujące się małą toksycznością zarówno w przypadku samych produktów jak i opakowań.

Firma D-Link zaleca, aby Państwo zawsze prawidłowo wyłączali z użytku swoje produkty D-Link, gdy nie są one wykorzystywane. Postępując w ten sposób pozwalają Państwo oszczędzać energię i zmniejszać emisje CO₂.

Aby dowiedzieć się więcej na temat produktów i opakowań mających wpływ na środowisko prosimy zapoznać się ze stroną Internetową www.dlinkgreen.com.

ČESKY



Tento symbol na výrobku nebo jeho obalu znamená, že podle místně platných předpisů se výrobek nesmí vyhazovat do komunálního odpadu, ale odeslat k recyklaci. Až výrobek doslouží, odnese jej prosím na sběrné místo určené místními úřady k tomuto účelu. Některá sběrná místa přijímají výrobky zdarma. Recyklací výrobku i obalu pomáháte chránit životní prostředí i lidské zdraví.

D-Link a životní prostředí

Ve společnosti D-Link jsme si vědomi vlivu našich provozů a výrobků na životní prostředí a snažíme se o minimalizaci těchto vlivů. Proto své výrobky navrhujeme a vyrábíme tak, aby byly co nejekologičtější, a ve výrobcích i obalech používáme recyklovatelné a nízkotoxické materiály.

Společnost D-Link doporučuje, abyste své výrobky značky D-Link vypnuli nebo vytáhli ze zásuvky vždy, když je nepoužíváte. Pomůžete tak šetřit energii a snížit emise CO₂.

Více informací o našich ekologických výrobcích a obalech najdete na adrese www.dlinkgreen.com.

PL

NL

CZ

MAGYAR



Ez a szimbólum a terméken vagy a csomagoláson azt jelenti, hogy a helyi törvényeknek és szabályoknak megfelelően ez a termék nem semmisíthető meg a háztartási hulladékkal együtt, hanem újrahasznosításra kell küldeni. Kérjük, hogy a termék élettartamának elteltét követően vigye azt a helyi hatóság által kijelölt gyűjtőhelyre. A termékek egyes helyeken ingyen elhelyezhetők. A termék és a csomagolás újrahasznosításával segíti védeni a környezetet és az emberek egészségét.

A D-Link és a környezet

A D-Linknél megértjük és elköteleztük magunkat a műveleteink és termékeink környezetre gyakorolt hatásainak csökkentésére. Az ezen hatás csökkentése érdekében a D-Link a lehető leginkább környezetbarát termékeket tervez és gyárt azért, hogy újrahasznosítható, alacsony károsanyag-tartalmú termékeket gyárt és csomagolásokat alkalmaz.

A D-Link azt javasolja, hogy mindig kapcsolja ki vagy húzza ki a D-Link termékeket a tápellátásból, ha nem használja azokat. Ezzel segít az energia megtakarításában és a széndioxid kibocsátásának csökkentésében.

Környezetbarát termékeinkről és csomagolásainkról további információkat a www.dlinkgreen.com weboldalon tudhat meg.

NORSK



Dette symbolet på produktet eller forpakningen betyr at dette produktet ifølge lokale lover og forskrifter ikke skal kastes sammen med husholdningsavfall, men leveres inn til gjenvinning. Vennligst ta det til et innsamlingssted anvist av lokale myndigheter når det er kommet til slutten av levetiden. Noen steder aksepteres produkter uten avgift. Ved på denne måten å gjenvinne produktet og forpakningen hjelper du å verne miljøet og beskytte folks helse.

D-Link og miljøet

Hos D-Link forstår vi oss på og er forpliktet til å minske innvirkningen som vår drift og våre produkter kan ha på miljøet. For å minimalisere denne innvirkningen designer og lager D-Link produkter som er så miljøvennlig som mulig, ved å bruke resirkulerbare, lav-toksiske materialer både i produktene og forpakningen.

D-Link anbefaler at du alltid slår av eller frakobler D-Link-produkter når de ikke er i bruk. Ved å gjøre dette hjelper du å spare energi og å redusere CO₂-utslipp.

For mer informasjon angående våre miljøansvarlige produkter og forpakninger kan du gå til www.dlinkgreen.com.

HU

DANSK



Dette symbol på produktet eller emballagen betyder, at dette produkt i henhold til lokale love og regler ikke må bortskaffes som husholdningsaffald, mens skal sendes til genbrug. Indlever produktet til et indsamlingssted som angivet af de lokale myndigheder, når det er nået til slutningen af dets levetid. I nogle tilfælde vil produktet blive modtaget gratis. Ved at indlevere produktet og dets emballage til genbrug på denne måde bidrager du til at beskytte miljøet og den menneskelige sundhed.

D-Link og miljøet

Hos D-Link forstår vi og bestræber os på at reducere enhver indvirkning, som vores aktiviteter og produkter kan have på miljøet. For at minimere denne indvirkning designer og producerer D-Link sine produkter, så de er så miljøvenlige som muligt, ved at bruge genanvendelige materialer med lavt giftighedsniveau i både produkter og emballage.

D-Link anbefaler, at du altid slukker eller frakobler dine D-Link-produkter, når de ikke er i brug. Ved at gøre det bidrager du til at spare energi og reducere CO₂-udledningerne.

Du kan finde flere oplysninger om vores miljømæssigt ansvarlige produkter og emballage på www.dlinkgreen.com.

NO

SUOMI



Tämä symboli tuotteen pakkauksessa tarkoittaa, että paikallisten lakien ja säännösten mukaisesti tätä tuotetta ei pidä hävittää yleisen kotitalousjätteen seassa vaan se tulee toimittaa kierrätettäväksi. Kun tuote on elinkaarensa päässä, toimita se lähimpään viranomaisten hyväksymään kierrätyspisteeseen. Kierrättämällä käytetyn tuotteen ja sen pakkauksen autat tukemaan sekä ympäristön että ihmisten terveyttä ja hyvinvointia.

D-Link ja ympäristö

D-Link ymmärtää ympäristönsuojelun tärkeyden ja on sitoutunut vähentämään tuotteistaan ja niiden valmistuksesta ympäristölle mahdollisesti aiheutuvia haittavaikutuksia. Nämä negatiiviset vaikutukset minimoidakseen D-Link suunnittelee ja valmistaa tuotteensa mahdollisimman ympäristöystävällisiksi käyttämällä kierrätettäviä, alhaisia pitoisuuksia haitallisia aineita sisältäviä materiaaleja sekä tuotteissaan että niiden pakkauksissa.

Suosittellemme, että irrotat D-Link-tuotteesi virtalähteestä tai sammutat ne aina, kun ne eivät ole käytössä. Toimimalla näin autat säästämään energiaa ja vähentämään hiilidioksiidipäästöjä.

Lue lisää ympäristöystävällisistä D-Link-tuotteista ja pakkauksistamme osoitteesta www.dlinkgreen.com.

DK

FI

SVENSKA

SE



Den här symbolen på produkten eller förpackningen betyder att produkten enligt lokala lagar och föreskrifter inte skall kastas i hushållssoporna utan i stället återvinnas. Ta den vid slutet av dess livslängd till en av din lokala myndighet utsedd uppsamlingsplats, vissa accepterar produkter utan kostnad. Genom att på detta sätt återvinna produkten och förpackningen hjälper du till att bevara miljön och skydda människors hälsa.

D-Link och miljö

På D-Link förstår vi och är fast beslutna att minska den påverkan våra verksamheter och produkter kan ha på miljön. För att minska denna påverkan utformar och bygger D-Link sina produkter för att de ska vara så miljövänliga som möjligt, genom att använda återvinningsbara material med låg gifthalt i både produkter och förpackningar.

D-Link rekommenderar att du alltid stänger av eller kopplar ur dina D-Link produkter när du inte använder dem. Genom att göra detta hjälper du till att spara energi och minska utsläpp av koldioxid.

För mer information om våra miljöansvariga produkter och förpackningar www.dlinkgreen.com.

PORTUGUÊS

PT



Este símbolo no produto ou embalagem significa que, de acordo com as leis e regulamentações locais, este produto não deverá ser eliminado juntamente com o lixo doméstico mas enviado para a reciclagem. Transporte-o para um ponto de recolha designado pelas suas autoridades locais quando este tiver atingido o fim da sua vida útil, alguns destes pontos aceitam produtos gratuitamente. Ao reciclar o produto e respectiva embalagem desta forma, ajuda a preservar o ambiente e protege a saúde humana.

A D-Link e o ambiente

Na D-Link compreendemos e comprometemo-nos com a redução do impacto que as nossas operações e produtos possam ter no ambiente. Para minimizar este impacto a D-Link concebe e constrói os seus produtos para que estes sejam o mais inofensivos para o ambiente possível, utilizando materiais recicláveis e não tóxicos tanto nos produtos como nas embalagens.

A D-Link recomenda que desligue os seus produtos D-Link quando estes não se encontrarem em utilização. Com esta acção ajudará a poupar energia e reduzir as emissões de CO2.

Para saber mais sobre os nossos produtos e embalagens responsáveis a nível ambiental visite www.dlinkgreen.com.

D-Link[®]



Ver. 1.02(WW)_130x183

2018/03/06



5300-00007299-01W