

**DAIKIN**

3P621327-2 E



DAIKIN ROOM AIR CONDITIONER

# INSTALLATION MANUAL



**R32 SPLIT SERIES**

## MODELS

<b>FTXC20DV1B</b>	<b>RXC20DV1B</b>
<b>FTXC25DV1B</b>	<b>RXC25DV1B</b>
<b>FTXC35DV1B</b>	<b>RXC35DV1B</b>
<b>FTXC50DV1B</b>	<b>RXC50DV1B</b>
<b>FTXC60DV1B</b>	<b>RXC60DV1B</b>
<b>FTXC71DV1B</b>	<b>RXC71DV1B</b>

Installation Manual  
R32 Split Series

**English**

# INSTALLATION MANUAL

## SAFETY PRECAUTIONS



Read the precautions in this manual carefully before operating the unit.



This appliance is filled with R32.

- The precautions described herein are classified as WARNING and CAUTION. They both contain important information regarding safety. Be sure to observe all precautions without fail.
- Meaning of WARNING and CAUTION notices.

### WARNING

Failure to follow these instructions properly may result in personal injury or loss of life.

### CAUTION

Failure to observe these instructions properly may result in property damage or personal injury, which may be serious depending on the circumstances.

- The safety marks shown in this manual have the following meanings:

	Be sure to follow the instructions.		Be sure to establish a ground connection.		Never attempt.
--	-------------------------------------	--	---	--	----------------

- After completing installation, conduct a trial operation to check for faults and explain to the customer how to operate the air conditioner and take care of it with the aid of operation manual.

### WARNING

- Ask your dealer or qualified person to carry out installation work.  
Do not attempt to install the air conditioner yourself. Improper installation may result in water leakage, electric shocks or fire.
- This appliance is not intended for use by persons, including children, with reduced physical, sensory or mental capabilities, or lack of experience and knowledge, unless they have been given supervision or instruction concerning use of the appliance by a person responsible for their safety.
- Children should be supervised to ensure that they do not play with the appliance.
- Install the air conditioner according to the instructions given in this manual.  
Incomplete installation may cause water leakage, electrical shock, or fire.
- Be sure to use only the specified accessories and parts for installation work.  
Failure to use the specified parts may result in the unit falling, water leakage, electric shocks or fire.
- Install the air conditioner on a foundation strong enough to withstand the weight of the unit.  
A foundation of insufficient strength may result in the equipment falling and causing injury.
- Electrical work must be performed in accordance with relevant local and national regulations and with instructions in this installation manual.  
Be sure to use a dedicated power supply circuit only. Insufficiency of power circuit capacity and improper workmanship may result in electric shocks or fire.
- Be sure to use a dedicated power supply circuit. Never use a power supply shared by another appliance.
- Use a cable of suitable length.  
Do not use tapped wires or an extension lead, as this may cause overheating, electric shocks or fire.
- Make sure that all wiring is secured, the specified wires are used, and that there is no strain on the terminal connections or wires.  
Improper connections or securing of wires may result in abnormal heat build-up or fire.
- When wiring the power supply and connecting the wiring between the indoor and outdoor units, position the wires so that the control box lid can be securely fastened.  
Improper positioning of the control box lid may result in electric shocks, fire or overheating terminals.
- After connecting interconnecting and supply wiring, be sure to shape the cables so that they do not put undue force on the electrical covers or panels. Install covers over the wires.  
Incomplete cover installation may cause terminal overheating, electrical shocks, or fire.
- When installing or relocating the air conditioner, be sure to bleed the refrigerant circuit to ensure it is free of air, and use only the specified refrigerant (R32).  
The presence of air or other foreign matter in the refrigerant circuit cause abnormal pressure rise, which may result equipment damage and even injury.
- The installation height from the floor must be over 1.8m.
- If refrigerant gas leaks during installation, ventilate the area immediately.  
Toxic gas may be produced if the refrigerant comes into contact with fire.
- After completing installation, check for refrigerant gas leakage.  
Toxic gas may be produced if the refrigerant gas leaks into the room and comes into contact with a source of fire, such as a fan heater, stove or cooker.
- During pump-down, stop the compressor before removing the refrigerant piping.  
If the compressor is still running and the stop valve is open during pump-down, air will be sucked in when the refrigerant piping is removed, causing abnormal pressure in refrigeration cycle, which may result equipment damage and even injury.
- During installation, attach the refrigerant piping securely before running the compressor.  
If the refrigerant pipes are not attached and the stop valve is open when the compressor is run, air will be sucked in, causing abnormal pressure in the refrigeration cycle, which may result equipment damage and even injury.
- Be sure to earth the air conditioner.  
Do not earth the unit to a utility pipe, lightning conductor or telephone earth lead. Imperfect earthing may result in electric shocks.
- Be sure to install an earth leakage breaker. Failure to install an earth leakage breaker may result in electrical shocks, or fire.

## ⚠ WARNING

- All electrical wiring must not touch the water piping or any moving parts of the fan motors.
- Confirm that the unit has been switched OFF before installing or servicing the unit.
- Disconnect from the main power supply before servicing the air conditioner unit.
- DO NOT pull out the power cord when the power is ON.  
This may cause serious electrical shocks which may result in fire hazards.
- Keep the indoor and outdoor units, power cable and transmission wiring, at least 1m from TVs and radios, to prevent distorted pictures and static.  
Depending on the type and source of the electrical waves, static may be heard even when more than 1m away.
- Do not use means to accelerate the defrosting process (if applicable) or to clean, other than those recommended by the manufacturer.
- The appliance must be stored in a room without continuously operating ignition sources (for example: open flames, an operating gas appliance or an operating electric heater).
- Do not pierce or burn.
- Be aware that refrigerants may not contain an odour.
- The appliance must be installed, operated and stored in a room with a floor area larger than Xm<sup>2</sup> (refer to Section "Special Precautions When Dealing With R32 Unit").  
In case it does not satisfy minimum floor area, it requires to install at good ventilation room.
- NOTE: The manufacturer may provide other suitable examples or may provide additional information about the refrigerant odour.

## ⚠ CAUTION

- Do not install the air conditioner at any place where there is danger of flammable gas leakage.  
In the event of a gas leakage, build-up of gas near the air conditioner may cause a fire to break out.
- While following the instructions in this installation manual, install drain piping to ensure proper drainage and insulate piping to prevent condensation.  
Improper drain piping may result in indoor water leakage and property damage.
- Tighten the flare nut according to specified method such as with a torque wrench.  
If the flare nut is too tight, it may crack after prolonged use, causing refrigerant leakage.
- Do not overcharge the unit.  
This unit is factory pre-charged. Overcharge will cause over-current or damage to the compressor.
- Ensure that the unit's panel is closed after service or installation.  
Unsecured panels will cause the unit to operate noisily.
- Sharp edges and coil surfaces are potential locations which may cause injury hazards.  
Avoid from being in contact with these places.
- Before turning off the power supply set the remote controller's ON/OFF switch to the "OFF" position to prevent the nuisance tripping of the unit.  
If this is not done, the unit's fans will start turning automatically when power resumes, posing a hazard to service personnel or the user.
- Make sure to provide for adequate measure in order to prevent that the outdoor unit be used as a shelter by small animals. Small animal making contact with electrical parts can cause malfunctions, smoke or fire.  
Please instruct the customer to keep the area around the unit clean.
- The temperature of refrigerant circuit will be high, please keep the inter-unit wiring away from copper pipes that are not thermally insulated.
- Only qualified personnel can handle, fill, purge and dispose of the refrigerant.

## NOTICE

### Disposal requirement

Your air conditioning product is marked with this symbol. This means that electrical and electronic products shall not be mixed with unsorted household waste. Do not try to dismantle the system yourself; the dismantling of the air conditioning system, treatment of the refrigerant, of oil and of other parts must be done by a qualified installer in accordance with relevant local and national legislation. Air conditioners must be treated at a specialized treatment facility for re-use, recycling and recovery. By ensuring this product is disposed of correctly, you will help to prevent potential negative consequences for the environment and human health. Please contact the installer or local authority for more information. Batteries must be removed from the remote controller and disposed of separately in accordance with relevant local and national legislation.



## IMPORTANT

### Important information regarding the refrigerant used

This product contains fluorinated greenhouse gases.

Do not vent gases into the atmosphere.

Refrigerant type: R32

GWP <sup>(1)</sup> value: 675

<sup>(1)</sup> GWP = Global Warming Potential

1 Please fill in with indelible ink,

- ① the factory refrigerant charge of the product,
- ② the additional refrigerant amount charged in the field and
- ① + ② the total refrigerant charge on the refrigerant charge label supplied with the product.

The filled out label must be adhered in the proximity of the product charging port (e.g. onto the inside of the service cover).

- Factory refrigerant charge: see unit name plate
- Additional refrigerant amount charged
- Total refrigerant charge

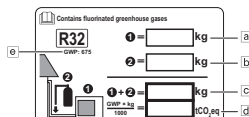

- Quantity of fluorinated greenhouse gases of the total refrigerant charge expressed as tonnes CO<sub>2</sub> equivalent.
- GWP = Global warming potential

## ⚠ NOTICE

Applicable legislation on **fluorinated greenhouse gases** requires that the refrigerant charge of the unit is indicated both in weight and CO<sub>2</sub> equivalent.

**Formula to calculate the quantity in CO<sub>2</sub> equivalent tonnes:** GWP value of the refrigerant × total refrigerant charge [in kg] / 1000

- Fix the label on the inside of the outdoor unit. There is a dedicated place for it on the wiring diagram label.

# ACCESSORIES

Ⓐ Mounting plate	1	Ⓑ Remote controller holder	1	Ⓒ AAA dry-cell batteries	2
Ⓓ Wireless remote controller	1	Ⓔ Fixing screws for remote controller holder M3 x 16L	2	Ⓕ Titanium apatite deodorizing filter	2
Ⓒ Drain socket	1	Ⓕ Drain cap * Only for heat pump models.	1	Ⓖ Installation manual	1
				Ⓗ Operation manual	1

## CHOOSING AN INSTALLATION SITE

- Before choosing the installation site, obtain user approval.

### Indoor Unit

The indoor unit should be sited in a place where:

- The restrictions on installation specified in the indoor unit installation drawing are met.
- Both air intake and exhaust have clear paths met.
- The unit is not in the path of direct sunlight.
- The unit is away from the sources of heat or steam.
- There is no source of machine oil vapour (this may shorten indoor unit life).
- Cool air is circulated throughout the room.
- The unit is away from electronic ignition type fluorescent lamps (inverter or rapid start type). As these may shorten the remote controller range.
- The unit is at least 1 metre away from any television or radio set (unit may cause interference with the picture or sound).
- Install at the recommended height (more than 1.8m).
- Do not install the units at or near doorway.
- Do not operate any heating apparatus too close to the air conditioner unit or use in room where mineral oil, oil vapour or oil steam exist, this may cause plastic part to melt or deform as a result of excessive heat or chemical reaction.
- When the unit is used in kitchen, keep flour away from going into suction of the unit.
- This unit is not suitable for factory used where cutting oil, mist or iron powder exist or voltage fluctuates greatly.
- Do not install the units at area like hot spring or oil refinery plant where sulphide gas exists.
- Ensure the color of wires of the outdoor unit and the terminal markings are same to the indoors respectively.
- **IMPORTANT : DO NOT INSTALL OR USE THE AIR CONDITIONER UNIT IN A LAUNDRY ROOM.**  
Do not use joined and twisted wires for incoming power supply. The equipment is not intended for use in a potentially explosive atmosphere

### Wireless Remote Controller

- Do not expose the remote controller to direct sunlight (this will hinder receiving signals from the indoor unit).
- Turn on all the fluorescent lamps in the room, if any, and find the site where remote controller signals are properly received by the indoor unit (within 7 metres).

### Outdoor Unit

The outdoor unit should be sited in a place where:

- The restrictions on installation specified in the outdoor unit installation drawing are met.
- Drain water causes no trouble or problem in particular.
- Both air intake and exhaust have clear paths of air.
- The unit is in a clear path of air but not directly exposed to rain, strong winds, or direct sunlight.
- There is not fear of inflammable gas leakage.
- The unit is not directly exposed to salt, sulfidized gases, or machine oil vapour (they may shorten outdoor unit life).
- Operation noise or hot (cold) air flow does not cause trouble to neighbours.
- The unit is at least 3 metres away from any television or radio antenna.
- Condensation dripping from the stop valve cannot damage anything during operation.

### ⚠ CAUTION

When operating the air conditioner in a low outdoor ambient temperature, be sure to follow the instructions described below.

- To prevent exposure to wind, install the outdoor unit with its suction side facing the wall.
- Never install the outdoor unit at a site where the suction side may be exposed directly to wind.
- To prevent exposure to wind, it is recommended to install a baffle plate on the air discharge side of the outdoor unit.
- In heavy snow areas, select an installation site where the snow will not affect the unit.
- If there is a likelihood of snow accumulating on the outdoor unit, attach a snow protection hood.
- In high humidity areas or heavy snow areas, it is recommended to attach a drain pan heater to prevent ice build-up from the bottom frame.

- Construct a large canopy.
- Construct a pedestal.



Install the unit high enough off the ground to prevent burying in snow

### ⚠ CAUTION

Do not install the unit at altitude over 2000m for both indoor and outdoor.

# INDOOR/OUTDOOR UNIT INSTALLATION DRAWINGS

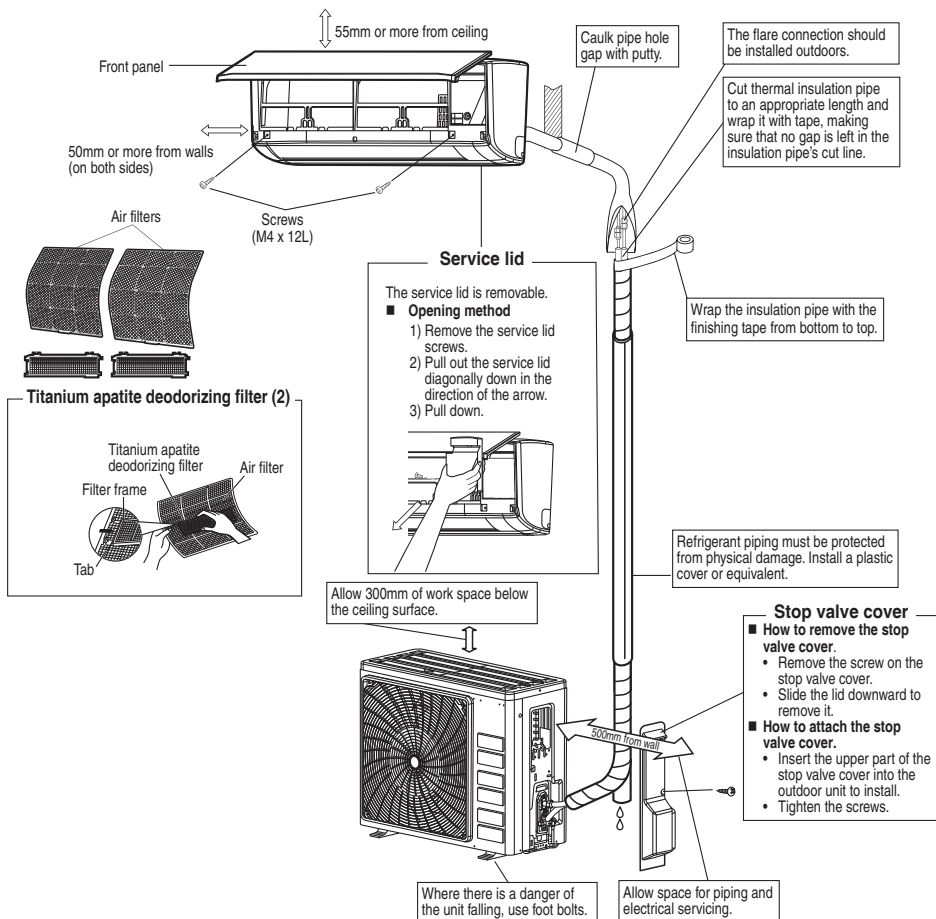

	RXC20/25/35	RXC50/60/71
Max. allowable piping length	20m	30m
Min. allowable piping length**	3m	
Max. allowable piping height	15m	20m
Additional refrigerant required for refrigerant pipe exceeding 7.5m in length*	17g/m	
Gas pipe	3/8 inch (9.5mm)	1/2 inch (12.7mm)
Liquid pipe	1/4 inch (6.4mm)	

\* Be sure to add the proper amount of additional refrigerant. Failure to do so may result in reduced performance.

\*\* The suggested shortest pipe length is 10ft (3m), in order to avoid noise from the outdoor unit and vibration. (Mechanical noise and vibration may occur depending on how the unit is installed and the environment in which it is used.)

# INDOOR INSTALLATION GUIDELINE

## INSTALLING THE MOUNTING PLATE

- The mounting plate should be installed on a wall which can support the weight of the indoor unit.
- Temporarily secure the mounting plate to the wall, make sure that the panel is completely level, and mark the drilling points on the wall.
  - Secure the mounting plate to the wall with screws.

### Recommended mounting plate retention spots and dimensions

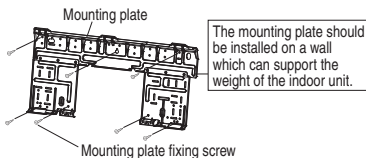

### INDOOR UNIT FTXC20/25/35/50

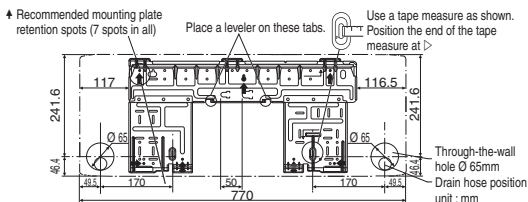

All dimensions are in mm

### INDOOR UNIT FTXC60/71

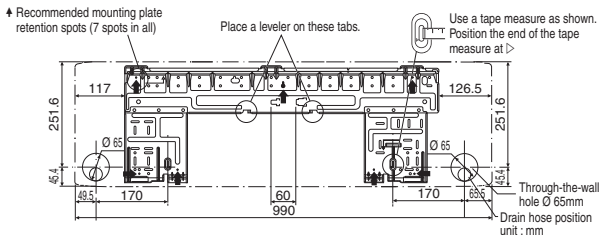

All dimensions are in mm

## DRILLING A WALL HOLE AND INSTALLING WALL EMBEDDED PIPE

- For walls containing metal frame or metal board, be sure to use a wall embedded pipe and wall cover in the feed-through hole to prevent possible heat, electrical shock, or fire.
  - Be sure to caulk the gaps around the pipes with caulking material to prevent water leakage.
- Drill a feed-through hole of 65mm in the wall so it has a down slope toward the outside.
  - Insert a wall pipe into the hole.
  - Insert a wall cover into wall pipe.
  - After completing refrigerant piping, wiring, and drain piping, caulk pipe hole gap with putty.

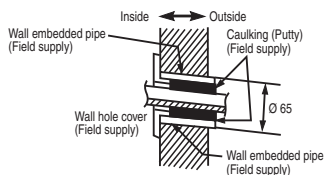

# INSTALLING INDOOR UNIT

## Right-side, right-back, or right-bottom piping.

- 1) Attach the drain hose to the underside of the refrigerant pipes with adhesive vinyl tape.
- 2) Wrap the refrigerant pipes and drain hose together with insulation tape.
- 3) Pass the drain hose and refrigerant pipes through the wall hole, then set the indoor unit on the mounting plate hooks by using the  $\triangle$  markings at the top of the indoor unit as a guide.
- 4) Open the front panel, then open the service lid.  
(Refer to installation tips.)
- 5) Pass the inter-unit wire from the outdoor unit through the feed-through wall hole and then through the back of the indoor unit.  
Pull them through the front side. Bend the ends of tie wires upward for easier work in advance. (If the inter-unit wire ends are to be stripped first, bundle wire ends with adhesive tape.)
- 6) Press the bottom frame of the indoor unit with both hands to set it on the mounting plate hooks. Make sure the wires leads do not catch on the edge of the indoor unit.

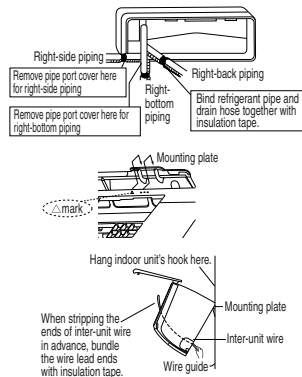

## Left-side, left-back, or left-bottom piping.

### How to replace the drain plug and drain hose

#### Removal method

- 1) Rotate to detach wire clip from hook on the right and remove the drain hose.
- 2) Remove the drain plug on the left side and attach it to the right side.
- 3) Insert the drain hose and tighten by rotating the wire clip to hook.  
Forgetting to tighten this may cause water leakages.

#### Drain hose attachment position

The drain hose is on the back of the unit.

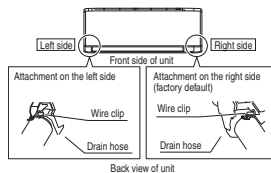

- 1) Attach the drain hose to the underside of the refrigerant pipes with adhesive vinyl tape.
- 2) Be sure to connect the drain hose to the drain port in place of a drain plug.
- 3) Shape the refrigerant pipe along the pipe path marking on the mounting plate.
- 4) Pass drain hose and refrigerant pipes through the wall hole, then set the indoor unit on mounting plate hooks, using the  $\triangle$  markings at the top of indoor unit as a guide.
- 5) Pull in the inter-unit wiring.
- 6) Connect the inter-unit piping.

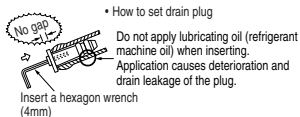
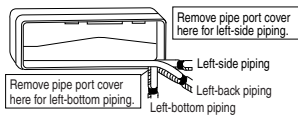
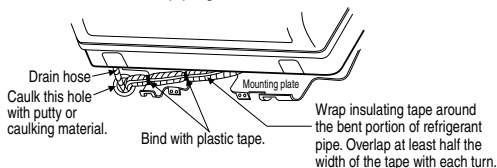

- 7) Wrap the refrigerant pipes and drain hose together with insulation tape as right figure.

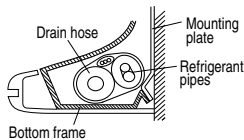

**Wall embedded piping.**

Follow the instructions given

**Left-side, left-back, or left-bottom piping**

- 1) Insert the drain hose to this depth so it won't be pulled out of the drain pipe.

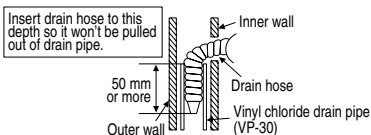

The indoor unit must be installed in such a way so as to prevent short circuit of the cool discharged air with the hot return air. Please follow the installation clearance shown in the figure. Do not place the indoor unit where there could be direct sunlight shining on it. Also, this location must be suitable for piping and drainage, and be away from doors or windows.

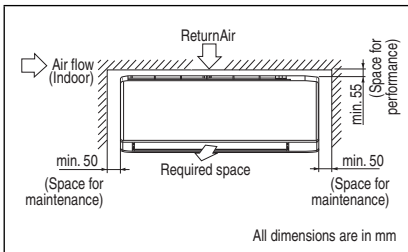

- **How to attach the indoor unit**  
Hook the claws of the bottom frame to the mounting plate.

- **How to remove the indoor unit.**  
Push up the marked area (at the lower part of the front grille) to release the claws.

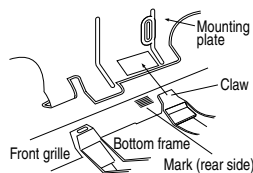

**DRAIN PIPING**

- Connect the drain hose, as described below.

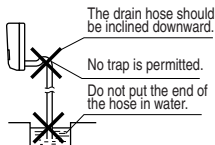

- When drain hose requires extension, obtain an extension hose commercially available. Be sure to thermally insulate the indoor section of the extension hose.

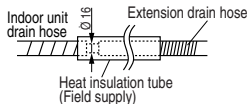

- Water Drainage

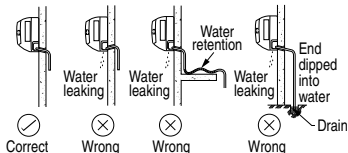

- When connecting a rigid polyvinyl chloride pipe (inside diameter 16mm) directly to the drain hose attached to the indoor unit as with embedded piping work, use any commercially available drain socket (inside diameter 16mm) as a joint.

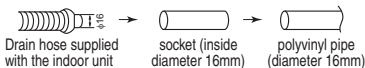

- Remove the air filters and pour some water into the drain pan to check the water flows smoothly.

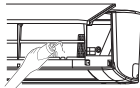



# WIRING

**IMPORTANT :** \* The figures shown in the table are for information purpose only. They should be checked and selected to comply with the local/national codes of regulations. This is also subject to the type of installation and conductors used.

\*\* The appropriate voltage range should be checked with label data on the unit.

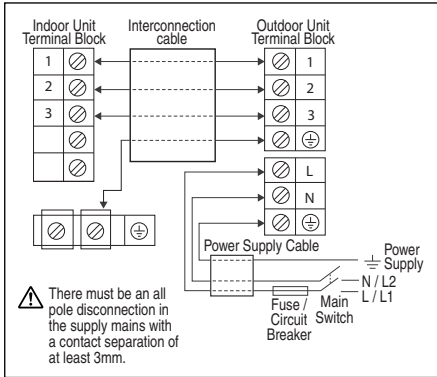

Model	Indoor (FTXC)	20/25/35D	50/60/71D
	Outdoor (RXC)	20/25/35D	50/60/71D
Voltage range**		220-240V/-/50Hz + ⊕	
Power supply cable size*	mm <sup>2</sup>	1.5	2.5
Number of conductors		3	3
Interconnection cable size*	mm <sup>2</sup>	1.5	1.5
Number of conductors		4	4
Recommended fuse / circuit breaker rating**	A	16	16

- All wires must be firmly connected.
- Make sure all the wire do not touch the refrigerant pipings, compressor or any moving parts.
- The connecting wire between the indoor unit and the outdoor unit must be clamped by using provided cord anchorage.
- The power supply cord must be equivalent to H07RN-F which is the minimum requirement.
- Make sure no external pressure is applied to the terminal connectors and wires.
- Make sure all the covers are properly fixed to avoid any gap.
- Use round crimp-style terminal for connecting wires to the power supply terminal block. Connect the wires by matching to the indication on terminal block. (Refer to the wiring diagram attached on the unit).

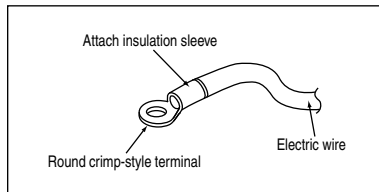

- Used the correct screwdriver for terminal screws tightening. Unsuitable screwdrivers can damage the screw head.
- Over tightening can damage the terminal screws.
- Do not connect wire of different gauge to same terminal.
- Keep wiring in an orderly manner. Prevent the wiring from obstructing other parts and the terminal box cover.

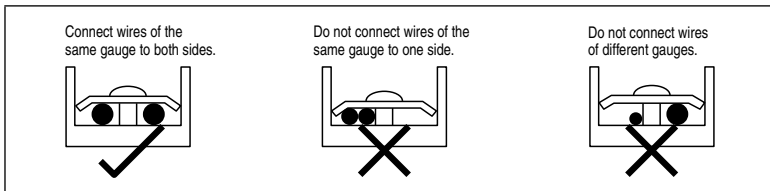

# OUTDOOR INSTALLATION GUIDELINE

## INSTALLING OUTDOOR UNIT

- Where a wall or other obstacle is in the path of outdoor unit's intake or exhaust airflow, follow the installation guidelines below.
- For any of the below installation patterns, the wall height on the exhaust side should be 1200mm or less.

### RXC20/25/35

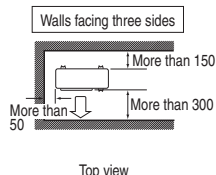
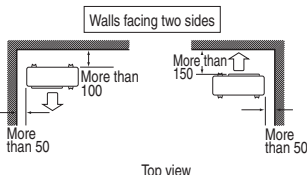
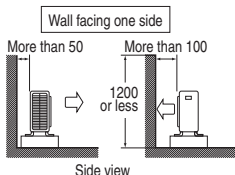

### RXC50/60/71

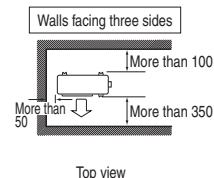
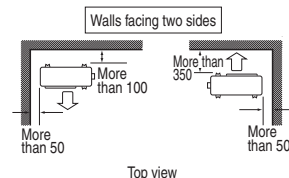
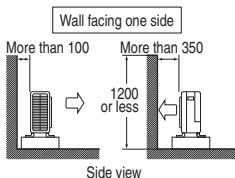

All dimensions are in mm

## DRAIN WORK

- 1) Use drain socket for drainage and attach drain cap.
- 2) If the drain port is covered by a mounting base or floor surface, place additional foot bases of at least 30mm (1-3/16") in height under the outdoor unit's feet.
- 3) In cold areas, do not use a drain socket, hose and caps with the outdoor unit.  
(Otherwise, drain water may freeze, impairing heating performance.)

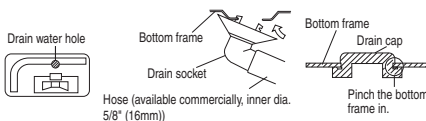

### CAUTION

If the unit is installed in a cold climate, take adequate measures so that the evacuated condensate CANNOT freeze.

## FLARING THE PIPE END

- 1) Cut the pipe end with a pipe cutter.
- 2) Remove burrs with the cut surface facing downward so that the chips do not enter the pipe.
- 3) Put the flare nut on the pipe.
- 4) Flare the pipe.
- 5) Check that the flaring is properly made.



### Flaring

Set exactly at the position shown below.

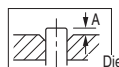

Pipe Size, mm (in)	Flare Tool for R32/R410A		Conventional flare tool	
	Clutch-type	Clutch-type (Rigid-type)	Clutch-type (Imperial-type)	Wing-nut type (Imperial-type)
6.4 (1/4")	0-0.5	1.0-1.5	1.5-2.0	
9.5 (3/8")	0-0.5	1.0-1.5	1.5-2.0	
12.7 (1/2")	0-0.5	1.0-1.5	2.0-2.5	
15.9 (5/8")	0-0.5	1.0-1.5	2.0-2.5	
19.1 (3/4")	0-0.5	1.0-1.5	2.0-2.5	

### Check

The pipe end must be evenly flared in a perfect circle.  
Make sure that the flare nut is fitted.



### WARNING

- Do not use mineral oil on flared part.
- Prevent mineral oil from getting into the system as this would reduce the lifetime of the units.
- Never use piping which has been used for previous installations.
- Only use parts which are delivered with the unit.
- Do never install a drier to this unit in order to guarantee its lifetime.
- The drying material may dissolve and damage the system.
- Incomplete flaring may cause refrigerant gas leakage.

### CAUTION

Do not reuse joints which have been used once already.

# REFRIGERANT PIPING

## ⚠ CAUTION

- 1) Use the flare nut fixed to the main unit. (To prevent cracking of the flare nut by aged deterioration.)
- 2) To prevent gas leakage, apply refrigeration oil only to the inner surface of the flare. (Use refrigeration oil for R32.)
- 3) Use torque wrenches when tightening the flare nuts to prevent damage to the flare nuts and gas leakage.

Align the centres of both flares and tighten the flare nuts 3 or 4 turns by hand. Then tighten them fully with the torque wrenches.

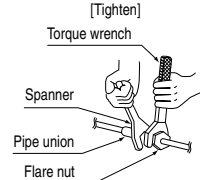
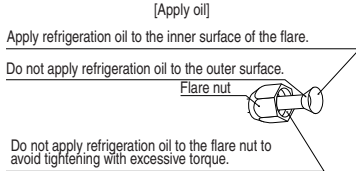

## 1. Cautions on pipe handling

- 1) Protect the open end of the pipe against dust and moisture.
- 2) All pipe bends should be as gentle as possible. Use a pipe bender for bending.

## 2. Selection of copper and heat insulation materials

When using commercial copper pipes and fittings, observe the following:

- 1) Insulation material: Polyethylene foam  
Heat transfer rate: 0.041 to 0.052W/mK (0.035 to 0.045kcal/(mh • °C)  
Refrigerant gas pipe's surface temperature reaches 110°C max.  
Choose heat insulation materials that will withstand this temperature.
- 2) Be sure to insulate both the gas and liquid piping and to provide insulation dimensions as below.

Pipe Size, mm (in)	Torque, Nm/(ft-lb)
6.4 (1/4")	18 (13.3)
9.5 (3/8")	42 (31.0)
12.7 (1/2")	55 (40.6)
15.9 (5/8")	65 (48.0)
19.1 (3/4")	78 (57.6)

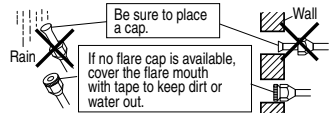

Piping size, mm (in)	Minimum bend radius	Piping thickness	Thermal insulation size	Thermal insulation thickness
6.4 (1/4")	30mm or more	0.8mm (C1220T-O)	I.D. 8-10mm	10mm Min.
9.5 (3/8")	30mm or more		I.D. 12-15mm	
12.7 (1/2")	40mm or more		I.D. 14-16mm	
15.9 (5/8")	50mm or more	1.0mm (C1220T-O)	I.D. 16-20mm	
19.1 (3/4")	50mm or more		I.D. 20-24mm	

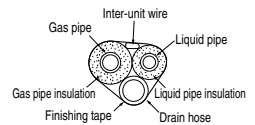

## ⚠ NOTICE

Do NOT exceed the unit's maximum working pressure (see "Max. Allowable Pressure" on the unit name plate).

# PURGING AIR AND CHECKING GAS LEAKAGE

- When piping work is completed, it is necessary to purge the air and check for gas leakage

## ⚠ WARNING

- 1) Do not mix any substance other than the specified refrigerant (R32) into the refrigeration cycle.
- 2) When refrigerant gas leaks occur, ventilate the room as soon and as much as possible.
- 3) R32, as well as other refrigerants, should always be recovered and never be released directly into the environment.
- 4) Use a vacuum pump for R32 exclusively. Using the same vacuum pump for different refrigerants may damage the vacuum pump or the unit.

- If using additional refrigerant, perform air purging from the refrigerant pipes and indoor unit using a vacuum pump, then charge additional refrigerant.
- Use a hexagonal wrench (4mm) to operate the stop valve rod.
- All refrigerant pipe joints should be tightened with a torque wrench at the specified tightening torque.

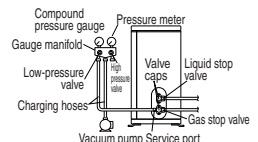

1) Connect projection side of charging hose (which comes from gauge manifold) to gas stop valve's service port.

2) Fully open gauge manifold's low-pressure valve (Lo) and completely close its high-pressure valve (Hi).  
(High-pressure valve subsequently requires no operation.)

3) Do vacuum pumping and make sure that the compound pressure gauge reads - 0.1MPa (- 760mmHg)\*1.

4) Close gauge manifold's low-pressure valve (Lo) and stop vacuum pump. (Keep this state for a few minutes to make sure that the compound pressure gauge pointer does not swing back.)\*2.

5) Remove covers from liquid stop valve and gas stop valve.

6) Turn the liquid stop valve's rod 90 degrees counterclockwise with a hexagonal wrench to open valve. Close it after 5 seconds, and check for gas leakage. Using soapy water, check for gas leakage from indoor unit's flare and outdoor unit's flare and valve rods. After the check is complete, wipe all soapy water off.

7) Disconnect charging hose from gas stop valve's service port, then fully open liquid and gas stop valves.  
(Do not attempt to turn valve rod beyond its stop.)

8) Tighten valve caps and service port caps for the liquid and gas stop valves with a torque wrench at the specified torques.

\*1. Pipe length vs. vacuum pump run time

Pipe length	Up to 15 metres	More than 15 metres
Run time	Not less than 10 min.	Not less than 15 min.

\*2. If the compound pressure gauge pointer swings back, refrigerant may have water content or a loose pipe joint may exist. Check all pipe joints and retighten nuts as needed, then repeat steps 2) through 4).

## PUMP DOWN OPERATION

**In order to protect the environment, be sure to pump down when relocating or disposing of the unit.**

- 1) Remove the valve lids from liquid stop valve and gas stop valve.
- 2) Carry out forced cooling operation.
- 3) After five to ten minutes, close the liquid stop valve with a hexagonal wrench.
- 4) After two to three minutes, close the gas stop valve and stop forced cooling

### Forced cooling operation

#### ■ Using the indoor unit ON/OFF switch

- Press the indoor unit ON/OFF switch for at least 5 seconds. (The operation will start.)
- Forced cooling operation will stop automatically after around 15 minutes.  
To stop the operation, press the indoor unit ON/OFF switch.

### ⚠ CAUTION

After closing the liquid stop valve, close the gas stop valve within 3 minutes, then stop the forced cooling operation.

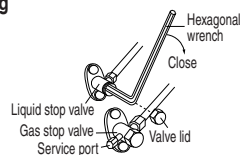

### To pump down

### ⚠ DANGER: RISK OF EXPLOSION

**Pump down - Refrigerant leakage.** If you want to pump down the system, and there is a leakage in the refrigerant circuit:

- Do NOT use the unit's automatic pump down function, with which you can collect all refrigerant from the system into the outdoor unit. Possible consequence: Self-combustion and explosion of the compressor because of air going into the operating compressor.
- Use a separate recovery system so that the unit's compressor does NOT have to operate.

### ⓘ NOTICE

During pump down operation, stop the compressor before removing the refrigerant piping. If the compressor is still running and the stop valve is open during pump down, air will be sucked into the system. Compressor breakdown or damage to the system can result due to abnormal pressure in the refrigerant cycle.

# WIRING

## ⚠ WARNING

- Do not use tapped wires, extension cords, or starburst connections, as they may cause overheating, electric shock, or fire.
  - Do not use locally purchased electrical parts inside the product. (Do not branch the power for the drain pump, etc., from the terminal block.) Doing so may cause electric shock or fire.
  - Be sure to install an earth leakage circuit breaker. (One that can handle higher harmonics.)  
(This unit uses an inverter. Therefore, an earth leakage circuit breaker capable of handling higher harmonics must be used in order to prevent the earth leakage circuit breaker malfunctioning.)
  - Use an all-pole disconnection type circuit breaker with at least 3mm (1/8 inch) between the contact point gaps.
  - When carrying out wiring, take care not to pull at the conduit.
  - Do not connect the power wire to the indoor unit. Doing so may cause electric shock or fire.
  - Do not turn on the circuit breaker until all work is completed.
- 1) Strip the insulation from the wire (20mm).
  - 2) Connect the inter-unit wires between the indoor and outdoor units so that the terminal numbers match. Tighten the terminal screws securely. It is recommended that a flathead screwdriver be used to tighten the screws. The screws are packed with the terminal block.

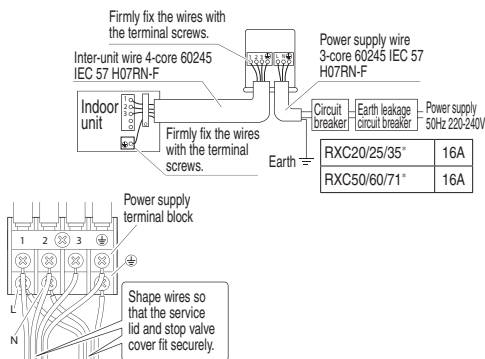

## SPECIAL PRECAUTIONS WHEN DEALING WITH R32 UNIT

Models	R32 charge, kg for 7.5m piping	Minimum floor area, Xm <sup>2</sup> (based on 7.5m piping)	R32 charge, kg for max allowable pipe length*	Minimum floor area, Xm <sup>2</sup> (based on max allowable pipe length*)
FTXC20D - RXC20D	0.55	0.29	0.76	0.55
FTXC25D - RXC25D	0.55	0.29	0.76	0.55
FTXC35D - RXC35D	0.75	0.54	0.96	0.88
FTXC50D - RXC50D	1.00	0.95	1.38	1.82
FTXC60D - RXC60D	1.10	1.15	1.48	2.10
FTXC71D - RXC71D	1.15	1.26	1.53	2.24

\* Max. Allowable Length (L),m for:-

FTXC20/25/35D - RXC20/25/35D : 20

FTXC50/60/71D - RXC50/60/71D : 30

- Installation of pipe work shall be kept to a minimum and pipe work shall be protected from physical damage and shall not be installed in an unventilated space.
- Reusable mechanical connectors and flare joints shall be accessible for maintenance purposes.

## **WARNING**

Prior to installation, ensure risk of ignition is minimised and avoid working in confined space.  
Ensure adequate ventilation is available by opening windows or doors.

- When flared joints are reused indoors, the flare part shall be re-fabricated.
- Avoid installation of the air conditioner in a place where there is danger of exposure to continuously operating open flames (for example an operating electric heaters).
- Any person who is involved with working on or breaking into a refrigerant circuit should hold a current valid certificate from an industry-accredited assessment authority, which authorises their competence to handle refrigerants safely in accordance with an industry recognised assessment specification.

### • **Checking for presence of refrigerant**

The area shall be checked with an appropriate refrigerant detector prior to and during work, to ensure the technician is aware of potentially flammable atmospheres. Ensure that the leak detection equipment being used is suitable for use with flammable refrigerants, i.e. nonsparking, adequately sealed or intrinsically safe.

### • **Presence of fire extinguisher**

If any hot work is to be conducted on the refrigeration equipment or any associated parts, appropriate fire extinguishing equipment shall be available to hand. Have a dry powder or CO<sub>2</sub> fire extinguisher adjacent to the charging area.

### • **No ignition sources**

All possible ignition sources, including cigarette smoking, should be kept sufficiently far away from the site of installation, repairing, removing and disposal, during which flammable refrigerant can possibly be released to the surrounding space. "No Smoking" signs shall be displayed.

### • **The following checks shall be applied to installations:**

- marking to the equipment continues to be visible and legible. Markings and signs that are illegible shall be corrected;
- refrigeration pipe or components are installed in a position where they are unlikely to be exposed to any substance which may corrode refrigerant containing components, unless the components are constructed of materials which are inherently resistant to being corroded or are suitably protected against being so corroded.

### • **Initial safety checks shall include:**

- that capacitors are discharged, this shall be done in a safe manner to avoid possibility of sparking
- there shall be no live electrical components and wiring are exposed while charging, recovering or purging the system;

### • **Repair to intrinsically safe components**

Do not apply any permanent inductive or capacitance loads to the circuit without ensuring that this will not exceed the permissible voltage and current permitted for the equipment in use.

Replace components only with parts specified by the manufacturer.

### • **Leak detection methods**

Ensure that the detector is not a potential source of ignition (for example a halide torch) and is suitable for the refrigerant used. Leak detection equipment shall be set at a percentage of the LFL of the refrigerant (for R32, LFL is 13%) and shall be calibrated to the refrigerant employed and the appropriate percentage of gas (25% maximum) is confirmed.

Leak detection fluids are suitable for use with most refrigerants but the use of detergents containing chlorine shall be avoided as the chlorine may react with the refrigerant and corrode the copper pipework. If a leak is suspected, all naked flames shall be removed/ extinguished. If a leakage of refrigerant is found which requires brazing, all of the refrigerant shall be recovered from the system, or isolated (by means of shut off valves) in a part of the system remote from the leak. Oxygen free nitrogen (OFN) shall then be purged through the system both before and during the brazing process.

### • **Removal and evacuation**

When breaking into the refrigerant circuit to make repairs – or for any other purpose – conventional procedures shall be used. However, it is important that best practice is followed since flammability is a consideration. The following procedure shall be adhered to:

- remove refrigerant;
- purge the circuit with inert gas;
- evacuate;
- purge again with inert gas;
- open the circuit by cutting or brazing.

The refrigerant charge shall be recovered into the correct recovery cylinders. The system shall be "flushed" with OFN to render the unit safe. This process may need to be repeated several times.

Compressed air or oxygen shall not be used for this task. Flushing shall be achieved by breaking the vacuum in the system with OFN and continuing to fill until the working pressure is achieved, then venting to atmosphere, and finally pulling down to a vacuum.

This process shall be repeated until no refrigerant is within the system. When the final OFN charge is used, the system shall be vented down to atmospheric pressure to enable work to take place. This operation is absolutely vital if brazing operations on the pipe-work are to take place. Ensure that the outlet for the vacuum pump is not close to any ignition sources and there is ventilation available.

#### • Labelling

This unit shall be labelled 'de-commissioned and emptied of refrigerant'. This label shall be dated and signed. Ensure that there are labels on the equipment stating the equipment contains flammable refrigerant.

#### • Charging procedures

In addition to conventional charging procedures, the following requirements shall be followed.

- Ensure that contamination of different refrigerants does not occur when using charging equipment. Hoses or lines shall be as short as possible to minimise the amount of refrigerant contained in them.
- Cylinders shall be kept upright.
- Ensure that the refrigeration system is earthed prior to charging the system with refrigerant.
- Label the system when charging is complete (if not already).
- Extreme care shall be taken not to overfill the refrigeration system.

Prior to recharging the system it shall be pressure tested with OFN. The system shall be leak tested on completion of charging but prior to commissioning. A follow up leak test shall be carried out prior to leaving the site.

#### Decommissioning

Before carrying out this procedure, it is essential that the technician is completely familiar with the equipment and all its detail. It is recommended good practice that all refrigerants are recovered safely. Prior to the task being carried out, an oil and refrigerant sample shall be taken in case analysis is required prior to re-use of reclaimed refrigerant. It is essential that electrical power is available before the task is commenced.

- a) Become familiar with the equipment and its operation.
- b) Isolate system electrically.
- c) Before attempting the procedure ensure that:
  - mechanical handling equipment is available, if required, for handling refrigerant cylinders;
  - all personal protective equipment is available and being used correctly;
  - the recovery process is supervised at all times by a competent person;
  - recovery equipment and cylinders conform to the appropriate standards.
- d) Pump down refrigerant system, if possible.
- e) If a vacuum is not possible, make a manifold so that refrigerant can be removed from various parts of the system.
- f) Make sure that cylinder is situated on the scales before recovery takes place.
- g) Start the recovery machine and operate in accordance with manufacturer's instructions.
- h) Do not overfill cylinders. (No more than 80% volume liquid charge).
- i) Do not exceed the maximum working pressure of the cylinder, even temporarily.
- j) When the cylinders have been filled correctly and the process completed, make sure that the cylinders and the equipment are removed from site promptly and all isolation valves on the equipment are closed off.
- k) Recovered refrigerant shall not be charged into another refrigeration system unless it has been cleaned and checked.

#### Recovery

When removing refrigerant from a system, either for servicing or decommissioning, it is recommended good practice that all refrigerants are removed safely. When transferring refrigerant into cylinders, ensure that only appropriate refrigerant recovery cylinders are employed. Ensure that the correct number of cylinders for holding the total system charge are available. All cylinders to be used are designated for the recovered refrigerant and labelled for that refrigerant (i.e. special cylinders for the recovery of refrigerant). Cylinders shall be complete with pressure relief valve and associated shut-off valves in good working order. Empty recovery cylinders are evacuated and, if possible, cooled before recovery occurs.

The recovery equipment shall be in good working order with a set of instructions concerning the equipment that is at hand and shall be suitable for the recovery of flammable refrigerants. In addition, a set of calibrated weighing scales shall be available and in good working order. Hoses shall be complete with leak-free disconnect couplings and in good condition. Before using the recovery machine, check that it is in satisfactory working order, has been properly maintained and that any associated electrical components are sealed to prevent ignition in the event of a refrigerant release. Consult manufacturer if in doubt.

The recovered refrigerant shall be returned to the refrigerant supplier in the correct recovery cylinder, and the relevant Waste Transfer Note arranged. Do not mix refrigerants in recovery units and especially not in cylinders.

If compressors or compressor oils are to be removed, ensure that they have been evacuated to an acceptable level to make certain that flammable refrigerant does not remain within the lubricant. The evacuation process shall be carried out prior to returning the compressor to the suppliers. Only electric heating to the compressor body shall be employed to accelerate this process. When oil is drained from a system, it shall be carried out safely.

# COMMISSIONING

## 1. CHECKLIST BEFORE COMMISSIONING

Do NOT operate the system before the following checks are OK:

<input type="checkbox"/>	The <b>indoor unit</b> is properly mounted.
<input type="checkbox"/>	The <b>outdoor unit</b> is properly mounted.
<input type="checkbox"/>	The system is properly <b>earthed</b> and the earth terminals are tightened.
<input type="checkbox"/>	The <b>fuses</b> or locally installed protection devices are installed according to this document, and have NOT been bypassed.
<input type="checkbox"/>	The <b>power supply voltage</b> matches the voltage on the identification label of the unit.
<input type="checkbox"/>	There are NO <b>loose connections</b> or damaged electrical components in the switch box.
<input type="checkbox"/>	There are NO <b>damaged components</b> or <b>squeezed pipes</b> on the inside of the indoor and outdoor units.
<input type="checkbox"/>	There are NO <b>refrigerant leaks</b> .
<input type="checkbox"/>	The <b>refrigerant pipes</b> (gas and liquid) are thermally insulated.
<input type="checkbox"/>	The correct pipe size is installed and the <b>pipes</b> are properly insulated.
<input type="checkbox"/>	The <b>stop valves</b> (gas and liquid) on the outdoor unit are fully open.
<input type="checkbox"/>	The following <b>field wiring</b> has been carried out according to this document and the applicable legislation between the outdoor unit and the indoor unit.
<input type="checkbox"/>	<b>Drainage</b> Make sure drainage flows smoothly. <b>Possible consequence:</b> Condensate water might drip.
<input type="checkbox"/>	The indoor unit receives the signals of the <b>user interface</b> .
<input type="checkbox"/>	The specified wires are used for the <b>interconnection cable</b> .

## 2. CHECKLIST DURING COMMISSIONING

<input type="checkbox"/>	To perform an <b>air purge</b> .
<input type="checkbox"/>	To perform a <b>test run</b> .

## INDICATION LIGHTS

### IR Signal Receiver

When an infrared remote control operating signal has been transmitted, the signal receiver on the indoor unit will respond as below to confirm acceptance of the signal transmission.

<b>ON to OFF</b>	1 Long Beep
<b>OFF to ON</b> <b>Pump down/Cool force on</b>	2 Short Beep
<b>Others</b>	1 Short Beep

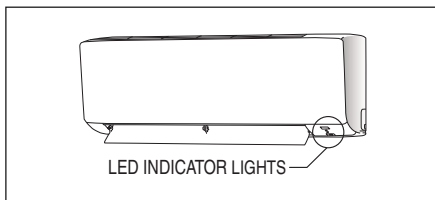

### Heatpump Unit

The table shows the LED indicator lights for the air conditioner unit under normal operation and fault conditions. The LED indicator lights are located at the side of the air conditioner unit.

The heat pump units are equipped with an “auto” mode sensor whereby it will provide reasonable room temperature by switching automatically to either “cool” or “heat” mode according to the temperature set by the user.

### LED Indicator Lights for Heatpump Unit

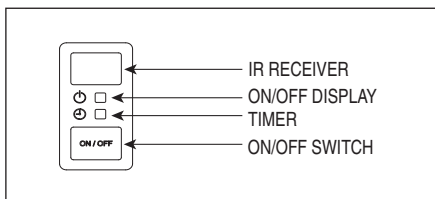



## LED Indicator Lights : Normal Operation & Fault Conditions For Heatpump Unit

Power Icon	Light Icon	Color	Operation
○	○	Green	Cool mode
○	○	Red	Heat mode
○	○	Green	Auto mode in Cooling operation
○	○	Red	Auto mode in Heating operation
○	○	Green	Fan mode on
○	○	Green	Dry mode on
○	○	Dimmed Green / Dimmed Red	Sleep mode on
○	○	Orange	Timer on
○	○	Red	Defrost operation
◐	○	Green	Unit error

○ ON

◐ Blinking

## OPERATING RANGE

Heat Pump Model

Model : FTXC 20/25/35 RXC 20/25/35

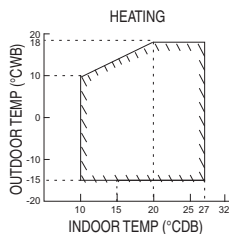
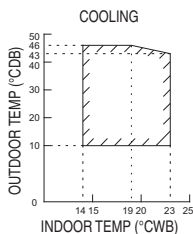

DB: Dry bulb WB: Wet bulb

Model : FTXC 50/60/71 RXC 50/60/71

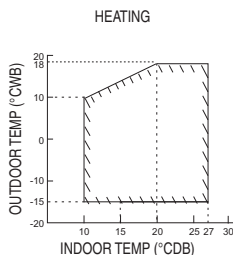
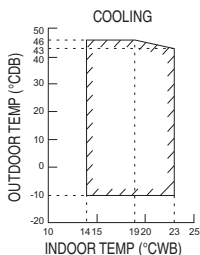

DB: Dry bulb WB: Wet bulb

# MAINTENANCE AND SERVICE



## NOTICE

Maintenance **MUST** be done by an authorized installer or service agent.  
We recommend performing maintenance at least once a year. However, applicable legislation might require shorter maintenance intervals.

### 1. Overview: Maintenance and service

This chapter contains information about:

- The yearly maintenance of the outdoor unit

### 2. Maintenance safety precautions



**DANGER: RISK OF ELECTROCUTION**



**DANGER: RISK OF BURNING**



## NOTICE: Risk of electrostatic discharge

Before performing any maintenance or service work, touch a metal part of the unit in order to eliminate static electricity and to protect the PCB.



## WARNING

- Before carrying out any maintenance or repair activity, **ALWAYS** switch off the circuit breaker on the supply panel, remove the fuses or open the protection devices of the unit.
- Do **NOT** touch live parts for 10 minutes after the power supply is turned off because of high voltage risk.
- Please note that some sections of the electric component box are hot.
- Make sure you do **NOT** touch a conductive section.
- Do **NOT** rinse the unit. This may cause electric shocks or fire.

### 3. Checklist for yearly maintenance of the outdoor unit

Check the following at least once a year:

- Outdoor unit heat exchanger.

The heat exchanger of the outdoor unit can get blocked up due to dust, dirt, leaves, etc. It is recommended to clean the heat exchanger yearly. A blocked heat exchanger can lead to too low pressure or too high pressure leading to worse performance.

# DISPOSAL



## NOTICE

Do **NOT** try to dismantle the system yourself: the dismantling of the system, treatment of the refrigerant, oil and other parts **MUST** comply with applicable legislation. Units **MUST** be treated at a specialised treatment facility for reuse, recycling and recovery.

- In the event that there is any conflict in the interpretation of this manual and any translation of the same in any language, the English version of this manual shall prevail.
- The manufacturer reserves the right to revise any of the specification and design contain herein at any time without prior notification.

### **DAIKIN EUROPE N.V.**

Zandvoordestraat 300, B-8400 Oostende,  
Belgium

### **DAIKIN MIDDLE EAST AND AFRICA FZE**

P.O.Box 18674, Jebel Ali Free Zone, Dubai-UAE  
Email: [info@daikinmea.com](mailto:info@daikinmea.com)  
Web: [www.daikinmea.com](http://www.daikinmea.com)

Importer for Turkey

### **DAIKIN ISITMA ve SOĞUTMA SİSTEMLERİ SAN TİC A.Ş.**

Allianz Plaza-Kucukbakkalkoy Mah.Kayisdagi Cad.No:1 34750  
Atasehir-ISTANBUL / TURKIYE

### **DAIKIN INDUSTRIES, LTD.**

Head office:  
Umeda Center Bldg., 2-4-12, Nakazaki-Nishi,  
Kita-ku, Osaka, 530-8323 Japan

Tokyo office:

JR Shinagawa East Bldg., 2-18-1, Konan,  
Minato-ku, Tokyo, 108-0075 Japan  
<http://www.daikin.com/global/>

### **DAIKIN MALAYSIA SDN. BHD.**

Lot 60334, Persiaran Bukit Rahman Putra 3,  
Taman Perindustrian Bukit Rahman Putra,  
47000 Sungai Buloh, Selangor Darul Ehsan,  
Malaysia.

## WARNING EXPLANATION



### **WARNING**

The unit is accompanied with the label below.  
Please read the following instructions carefully.

EN

- When the refrigeration circuit has a leak, do not execute pump down with the compressor.
- Use recovery system into separate cylinder.
- Warning, explosive hazard exists when executing pump down.
- Pump down with compressor can lead to self-combustion due to air entering during pump down.

Used symbols:

<sup>1)</sup> Warning sign (ISO 7010 – W001)

<sup>2)</sup> Warning, Explosive material (ISO 7010 – W002)

<sup>3)</sup> Read Operator's manual (ISO 7000 – 0790)

<sup>4)</sup> Operator's manual; operating instructions (ISO 7000 – 1641)

<sup>5)</sup> Service indicator; read technical manual (ISO 7000 – 1659)