



Questo manuale d'istruzione è fornito da trovaprezzi.it. Scopri tutte le offerte per [BenQ DVY23](#) o cerca il tuo prodotto tra le [migliori offerte di Webcam](#)



Questo manuale d'istruzione è fornito da trovaprezzi.it. Scopri tutte le offerte per [BenQ DVY23](#) o cerca il tuo prodotto tra le [migliori offerte di Web Cam](#)

DVY23 Full HD Camera User Manual



Disclaimer

BenQ Corporation makes no representations or warranties, either expressed or implied, with respect to the contents of this document. BenQ Corporation reserves the right to revise this publication and to make changes from time to time in the contents thereof without obligation to notify any person of such revision or changes.

Copyright

Copyright 2020 BenQ Corporation. All rights reserved. No part of this publication may be reproduced, transmitted, transcribed, stored in a retrieval system or translated into any language or computer language, in any form or by any means, electronic, mechanical, magnetic, optical, chemical, manual or otherwise, without the prior written permission of BenQ Corporation.

Table of Contents

Warning.....	5
Important notices	6
Use attention	6
Electric safety.....	6
Careful installation.....	6
Magnetic interference	7
Installation instructions	8
Product interface	8
Interface wiring	9
Bracket mount.....	9
Product overview	13
Remote control.....	18
Key instructions	18
Applications.....	20
Menu settings.....	22
Menu control key	22
Menu interface.....	22
Main menu	23
System setting.....	24
Camera setting	25
P/T/Z.....	29
Video Format.....	30
Version.....	30
Restore Default.....	31
Network connection	32
IE login.....	33
Web login.....	33

Streaming media	34
Software upgrade	36
Serial communication control.....	37
VISCA protocol list	37
Product information.....	54
Specifications.....	54
Dimensions.....	56
Maintenance and troubleshooting	57
Maintenance	57
Troubleshooting.....	57

Warning

The improper operation may destroy the structure of the product and lead to abnormal operation of the camera. Please pay attention to the following operations.

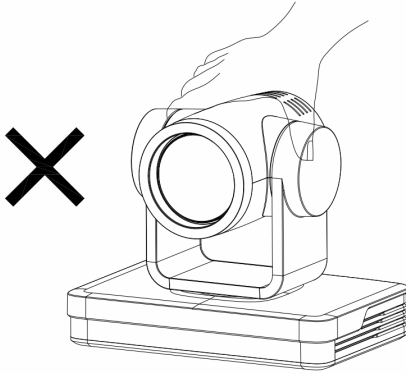

 Do not grasp the lens barrel with your hand while moving the camera.

 Move the camera by holding the bottom with both hands or one hand.

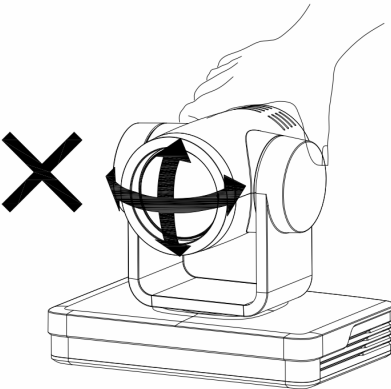

 Whether electrified or not, do not shake the lens and the platform by hand, otherwise it may damage the platform, resulting in abnormal self-examination of the camera, unable to start normally.

Important notices

This manual introduces functions, installation and operations for the camera in details. Please read this manual thoroughly before installation and use.

Use attention

- During transportation, storage, installation and use, it is necessary to prevent heavy pressure, severe vibration and immersion so as to avoid damage to products.
- The product shell is made of organic material. It is strictly forbidden to contact with corroded liquid, gas or solid substances.
- Don't let the product get wet or rained. Don't use it beyond the limit of temperature and humidity.
- When cleaning the camera lens, please wipe it with a dry soft cloth. When the product is heavily soiled, please wipe it gently with a neutral detergent. Do not use strong or corrosive cleaning agents to avoid scratching the lens and affecting the image quality.
- This product has no parts that users can repair by themselves, and the damage caused by users' self-disassembly does not fall within the scope of warranty.

Electric safety

- Installation and use of this product must strictly comply with the national and local electrical safety standards.
- Do not use power adapters beyond the specifications of the power supply, otherwise the equipment components will burn out and will not work properly.
- In the process of using the product, we should keep enough distance from the high-power equipment, and do a good job of lightning protection, surge protection and other protective measures when necessary.
- When the product is not in use, please disconnect the power switch and the power adapter from the power socket.
- The product uses DC 12V power supply; polarity of the power plug is shown below.

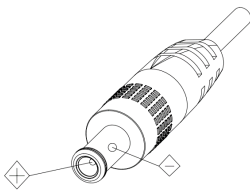

Careful installation

- Do not rotate the cylinder of the product by hand, otherwise it will destroy the rotating shaft of the structure or cause abnormal work of the signal line.
- Installation and placement of equipment should be horizontal and stable, and the product should not be tilted, otherwise the picture may be skewed.
- Make sure that there are no obstacles in the rotating range of the platform to prevent damage to the rotating shaft of the structure.
- Do not turn on power until all installation work is completed.

Magnetic interference

The electromagnetic field at a specific frequency may affect the local image. The product is Class A product. Radio interference may occur in the home environment, and users need to take appropriate measures.

Installation instructions

Product interface

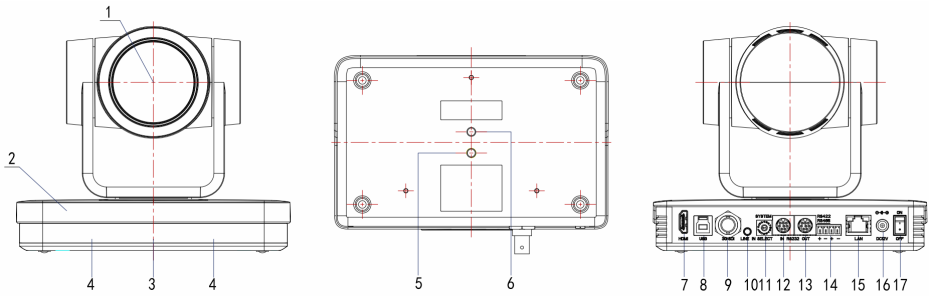

No.	Name
1	Lens
2	Camera base
3	Remote control receiver light
4	Infrared reception
5	Tripod screw hole
6	HDMI output
7	USB3.0 output (compatible with USB2.0)
8	SDI output
9	Audio input (LINE-IN)
10	Rotary dial switch
11	RS232 input
12	RS232 output
13	RS422 input (compatible with RS485)
14	Network LAN (Power over Ethernet)
15	Power In (DC 12V)
16	ON/ OFF switcher

Interface wiring

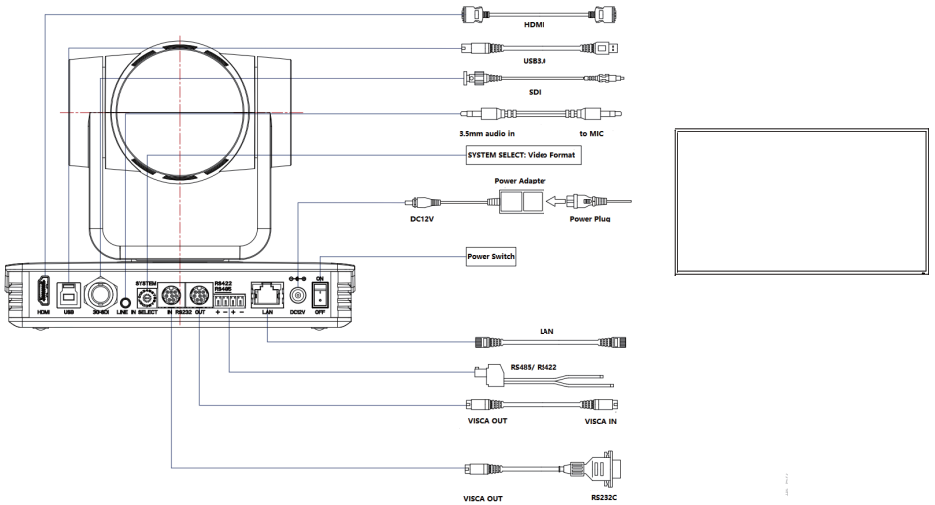

1. If the No. 0 preset is set, the camera will switch to the No. 0 preset when the power-on self-check is completed.
2. The default address of the remote control is 1#; the menu is restored to the factory default, and the address of the remote control is restored to 1#.

Bracket mount

Bracket can only be wall mounted or upside down mounted on template and concrete wall, but can not be installed on plasterboard.

1. Wall mount steps

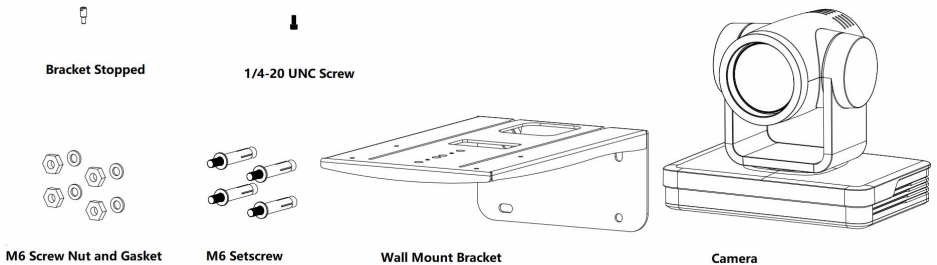

Step 1

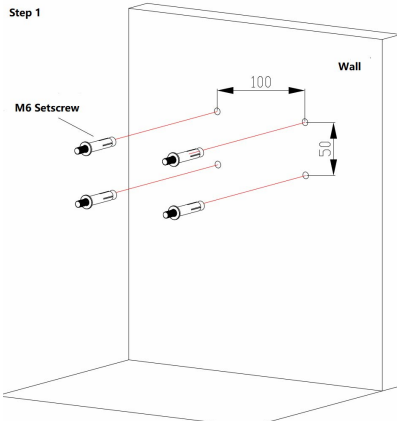

Step 2

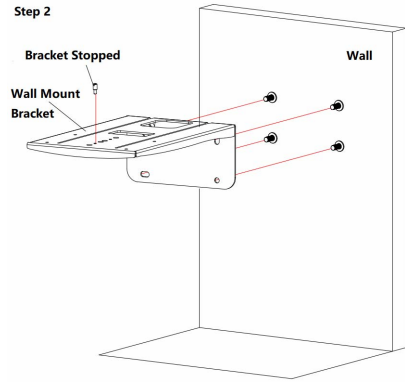

Step 3

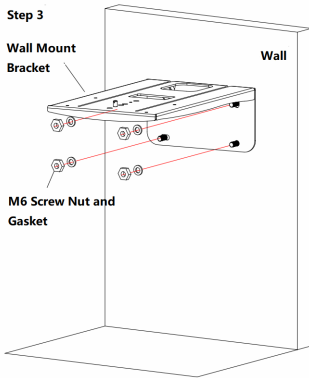

Step 4

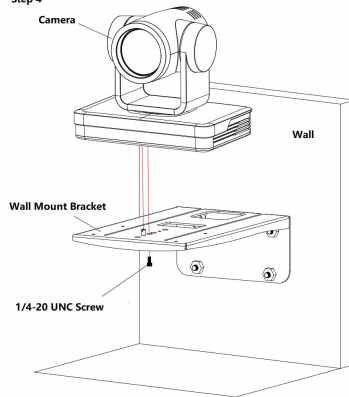

Step 5

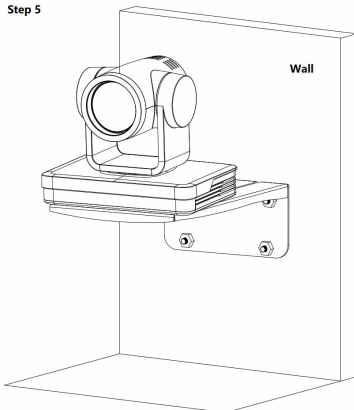

2. Ceiling mount steps

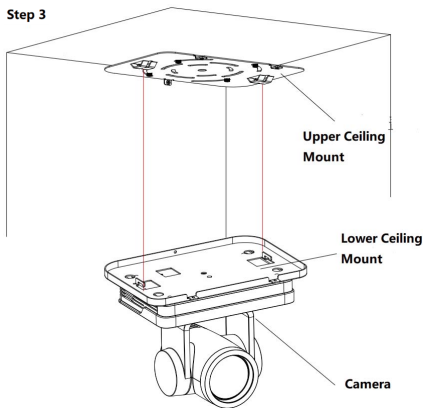
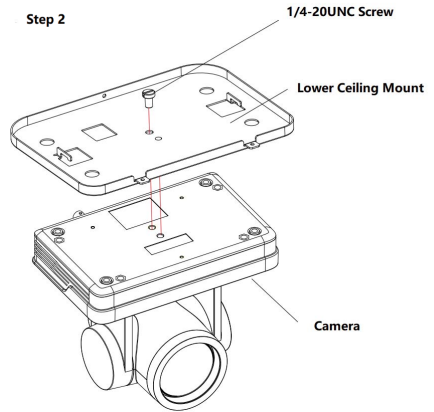
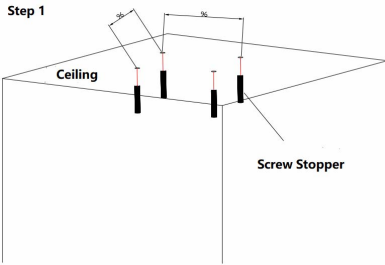
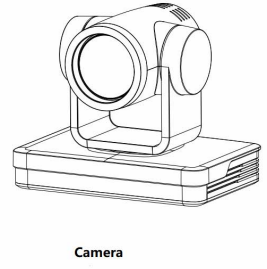
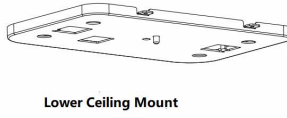
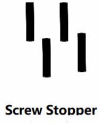

Step 4

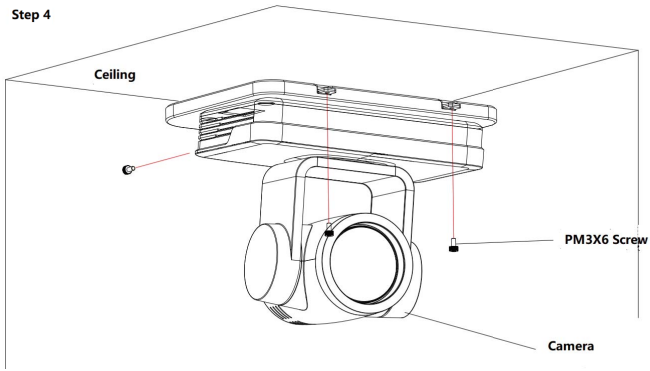

Product overview

Accessory

When you unpack, check that all the supplied accessories are included:

Configuration	Standard	Optional
Accessory	Power adapter*1	Upside-down ceiling mounting bracket
	USB3.0 cable*1	Wall mounting bracket
	RS232 cable*1	
	IR remote control*1	

RS-232 Interface

I. RS-232 interface

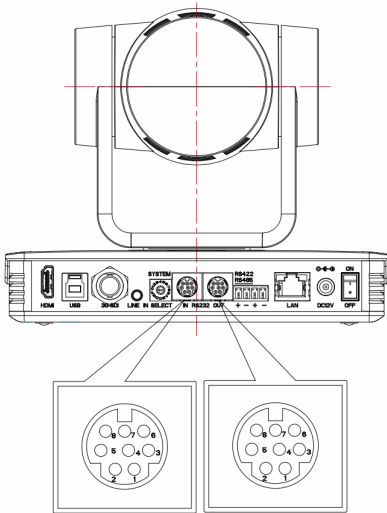

Computer or control keyboard and product connection method

Product	WindowsDB-9
1.DTR	1.DCD
2.DSR	2.RXD
3.TXD	3.TXD
4.GND	4.DTR
5.RXD	5.GND
6.GND	6.DSR
7.IR OUT	7.RTS
8.NC	8.CTS
	9.RI



2. Mini-DIN8-pin port

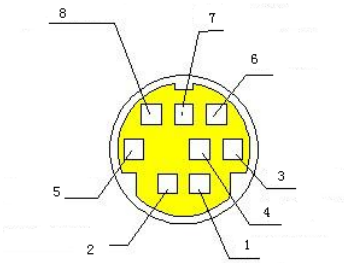

No.	Port	Definition
①	DTR	Data Terminal Ready
②	DSR	Data Set Ready
③	TXD	Transmit Data
④	GND	Signal ground
⑤	RXD	Receive Data
⑥	GND	Signal ground
⑦	IR OUT	IR Commander Signal
⑧	NC	No Connection

3. RS232(DB9) port

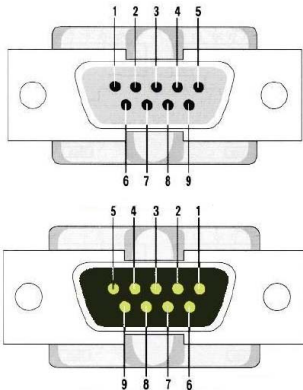

No.	Port	Definition
①	DCD	Data Carrier Detect
②	RXD	Receive Data
③	TXD	Transmit Data
④	DTR	Data Terminal Ready
⑤	GND	System Ground
⑥	DSR	Data Set Ready
⑦	RTS	Request to Send
⑧	CTS	Clear to Send
⑨	RI	Ring Indicator

4. VISCA networking mode is as follows:

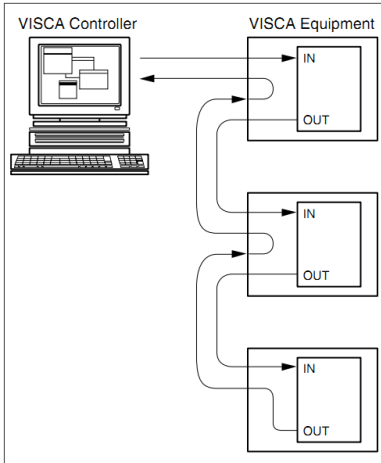

Product cascade connection Method

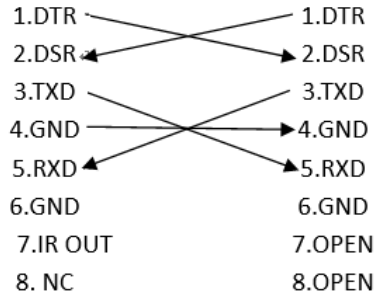

The product has RS232 input and output interface, which can be cascaded following the instructions shown above.

Rotary DIP Switch

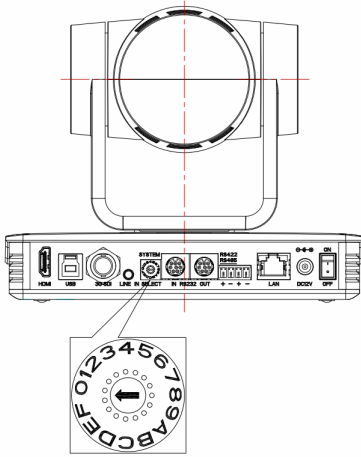

Dial-up	video format	Dial-up	video format
0	1080P60	8	1080P59.94
1	1080P50	9	1080I59.94
2	1080I60	A	1080P29.97
3	1080I50	B	720P59.94
4	1080P30	C	720P29.97
5	1080P25	D	
6	720P60	E	
7	720P50	F	video format to be set on the menu



- Remember to reboot the camera to take effect when switching video formats.
- If you switch to F, please turn off the camera and restart to take effect.

Main features

DVY23 offers perfect functions, superior performance and rich interfaces. The features include advanced ISP processing algorithms to provide vivid images with a strong sense of depth, high resolution and fantastic color rendition. It supports H.265/H.264 encoding which makes motion video fluent and clear even with less than ideal bandwidth conditions.

- Superb High-definition Image: Employs 1/2.8 inch high quality CMOS sensor. Resolution is up to 1920x1080 with frame rate up to 60fps.
- Built-in Gravity Sensor: Gravity sensor, support the automatic flip function of the gimbal, convenient for installation
- Whisper-quiet PTZ: High-precision stepper motor and motor drive controller ensure stable noise.
- Leading Auto Focus Technology: Leading auto focus algorithm makes lens a fast, accurate and stable auto-focusing.
- Low Noise and High SNR: Low Noise CMOS effectively ensure high SNR of camera video. Advanced 2D/3D noise reduction technology is also used to further reduce the noise, while ensuring image sharpness.
- Multiple Video Output Interfaces: Support HDMI, USB3.0, LAN. HDMI, LAN support audio output.
- USB3.0 Dual Stream: Supports both master and slave streams. The master and slave streams can be output simultaneously; YUY2, MJPEG, H.264, NV12, and H.265 video encoding formats are supported.
- Audio Input Interface: Support 48000 sampling frequency and AAC audio coding.
- Multiple Network Protocol: Support ONVIF, GB/T28181, RTSP, RTMP, VISCA OVER IP, IP VISCA, RTMPS, SRT protocols and support RTMP push mode, easy to link streaming media server (Wowza, FMS)
- Control Interface: RS422 (compatible with RS485), RS232; RS232 supports serial control.
- Multiple Control Protocol: Support VISCA, PELCO-D, PELCO-P protocols and automatic identification protocol.
- Multiple Preset: Support 255 preset positions (the remote control is set to 10 preset position)

Remote control

Remote controls are divided into two types: infrared remote controls and wireless remote controls. Please read the following according to the actual type of remote controls.

Key instructions

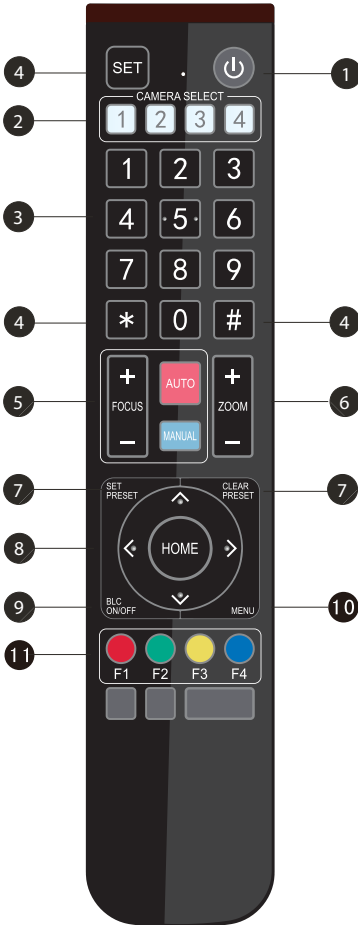

1 Standby Key

Long press the remote control for three seconds, the camera will step into standby mode. Long press the remote control for three seconds again, the camera will self-test again and back to HOME position.

Note: If preset 0 is set and there is no operation within 12 seconds, the camera head will automatically point to the specified preset 0 position.

2 Camera Address Selection

Select the camera address to be controlled.

3 Number Key

Set or call 0-9 presets.

4 *, # Key

Key combination use

5 Focus Control Key

Auto Focus: Enter the auto focus mode.

Manual Focus: The camera focus mode is manual. Switch the camera focus mode to manual focus by pressing [focus +] or [focus -] to adjust.

6 Zoom Control Key

Zoom+: Lens near

Zoom-: Lens far

7 Set or Clear Preset key

Set Preset: Set preset key + 0-9 number key

Clear Preset key: Clear preset key + 0-9 number key.

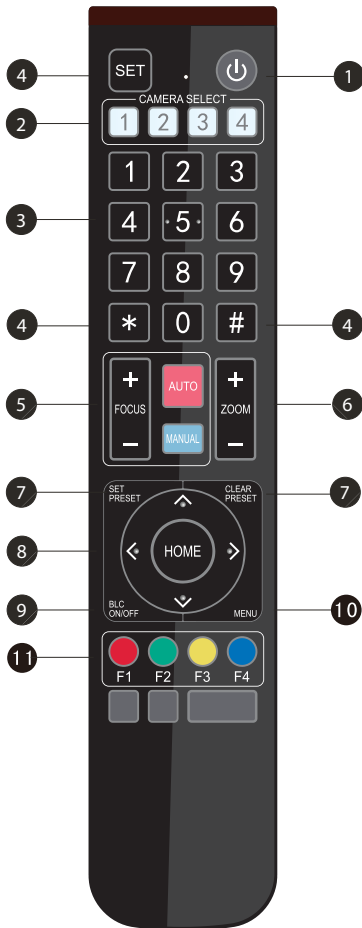

8 Pan/Tilt Control Key

Press Key: ▲

Press Key: ▼

Press Key: ◀

Press Key: ▶

“HOME” Key: Return to the middle position or enter the next level menu.

9 BLC Control Key

Back Light ON/OFF: Turn on or off the back light

10 Menu Setting

Open or close the OSD menu

Enter/exit the OSD menu or return to the previous menu

11 Camera IR Remote Control Address Setting

* + # + F1: Camera Address No.1

* + # + F2: Camera Address No. 2

* + # + F3: Camera Address No. 3

* + # + F4: Camera Address No. 4

12 Key Combination Functions



1. # + # + #: Clear all presets
2. * + # + 6: Restore factory defaults
3. * + # + 9: Flip switch
4. * + # + Auto: Enter the aging mode
5. * + # + 3: Menu set to Chinese
6. * + # + 4: Menu set to English
7. * + # + Manual: Restore the default user name, password, and IP address.
8. # + # + 0: Switch the video format to 1080P60
9. # + # + 1: Switch the video format to 1080P50
10. # + # + 2: Switch the video format to 1080i60
11. # + # + 3: Switch the video format to 1080i50
12. # + # + 4: Switch the video format to 720P60
13. # + # + 5: Switch the video format to 720P50
14. # + # + 6: Switch the video format to 1080P30
15. # + # + 7: Switch the video format to 1080P25
16. # + # + 8: Switch the video format to 720P30
17. # + # + 9: Switch the video format to 720P25



Applications

After finishing initialization, it can receive and execute the IR commands. Press the remote control button, and the indicator light will flash; release the button, and the indicator light stops flashing. Users can control the pan/tilt/zoom, setting and running preset positions via the IR remote control.

Key instructions

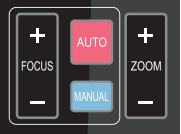
1. In this instruction, “press the key” means a click rather than a long-press, and a special note will be given if a long-press for more than one second is required.
2. When a key-combination is required, do it in sequence. For example, “* + # + F1” means press “*” first and then press “#” and last press “F1”.

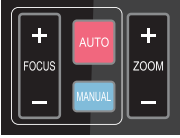
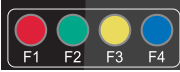
Items	Instruction
<p>1. Camera Selection</p> 	<p>Select the camera address to control.</p>
<p>2. Pan/Tilt Control</p> 	<ul style="list-style-type: none"> • Press ▲/▼/◀/▶ • Press “HOME” to go back to the middle position • Press and hold the ▲/▼/◀/▶ key, and the pan/tilt will keep running, from slow to fast, until it runs to the end point; the pan/tilt running stops as soon as the key is released.
<p>3. Presets</p> 	<ul style="list-style-type: none"> • Preset setting: To set a preset position, the users should press the “SET PRESET” key first and then press the number key 0-9 to set a relative preset. <p>Note: 10 preset positions in total are available by the remote control.</p> <ul style="list-style-type: none"> • Preset running: Press a number key 0-9 directly to run a relative preset. <p>Note: Action in vain if a relative preset position is not existed.</p> <ul style="list-style-type: none"> • Preset clearing: To clear a preset position, the user can press the “CLEAR PRESET” key first and then press the number key 0-9 to clear the relative preset. <p>Note: Press the “#” key three times continually to cancel all the presets.</p>
<p>4. Zoom Control</p> 	<p>ZOOM IN: Press “ZOOM ▲” key ZOOM OUT: Press “ZOOM ▼” key</p> <p>Press and hold the key, the camera will keep zooming in or out and stops as soon as the key is released.</p>

<p>5. Focus Control</p> 	<p>Focus (near): Press “focus +” key (Valid only in manual focus mode) Focus (far): Press “focus -” key (Valid only in manual focus mode) Auto Focus: Yes Manual Focus: Yes Press and hold the key, then the action of focus will continue and stops as soon as the key is released.</p>
<p>6. Address Setting</p> 	<p>* + # + F1: Camera Address No. 1 * + # + F2: Camera Address No. 2 * + # + F3: Camera Address No. 3 * + # + F4: Camera Address No. 4</p>
<p>7. BLC Setting</p> 	<p>BLC ON / OFF: Yes</p>

Menu settings

To modify the parameters in the menu, you need to exit the menu before you can save it by power off.

Menu control key

1. MENU: Enter/exit OSD menu or return to previous menu.
2. HOME: Go to the next menu.
3. ▲/▼: Select controls.
4. ◀/▶: Modify parameter values.

Menu interface

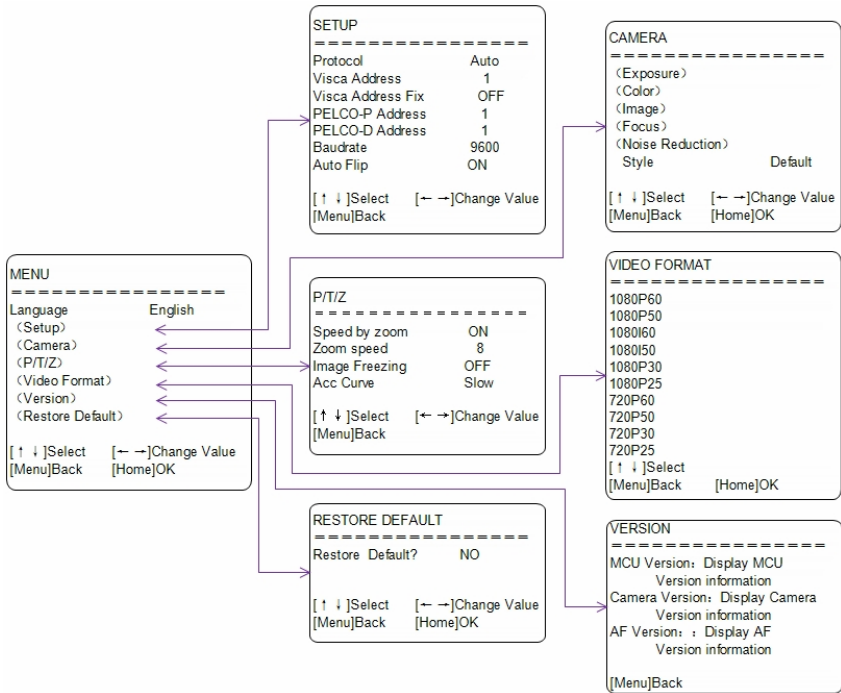

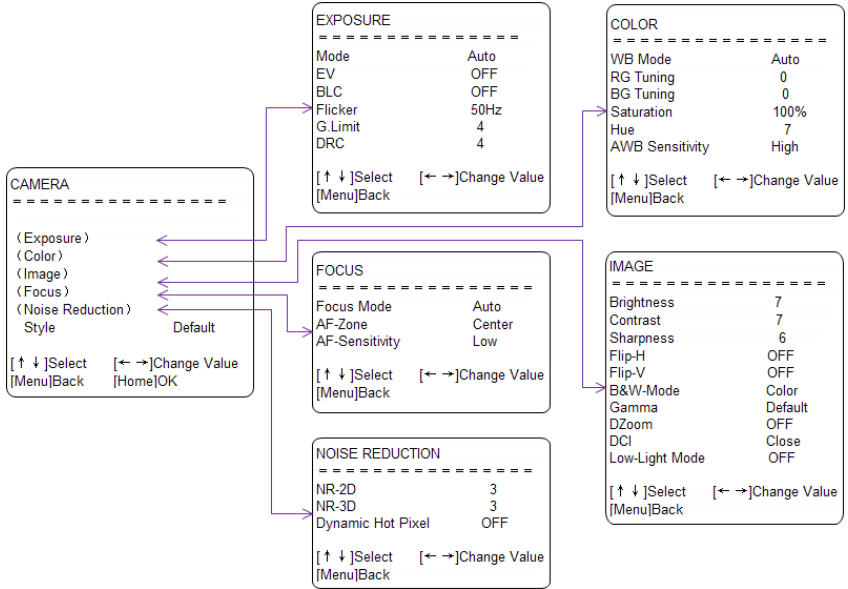

Main menu

In the normal working mode, press the MENU key to display the menu, then use the scroll arrow to point at or highlight the selected items.

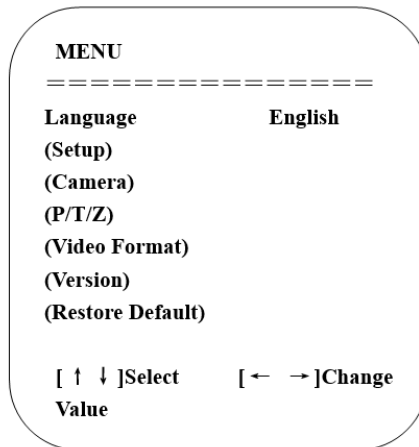

No.	Name	Descriptions
①	Language	Chinese/English
②	Setup	Enter System setting.

3	Camera option	Enter Camera setting.
4	PTZ option	Enter Pan tilt setting.
5	Version	Enter Camera version setting.
6	Restore Default	Enter Reset setting.
7	▲ ▼ Select	For selecting menu
8	◀ ▶ Change Value	For modify parameters
9	[MENU] Back	Press MENU to return.
10	[HOME] OK	Press HOME to confirm.

System setting

Move the pointer to Setup in the main menu, then click the HOME key and enter SETUP as below.

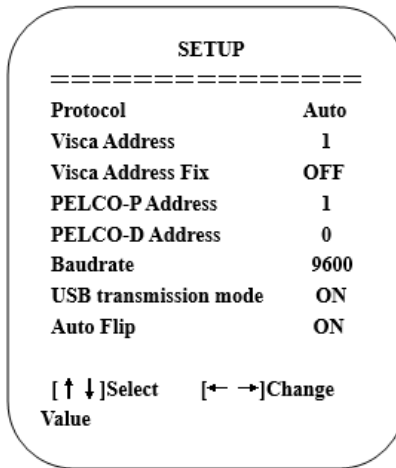

No.	Name	Descriptions
1	Protocol	VISCA/Pelco-P/Pelco-D/Auto • VISCA=1~7
2	Visca ADDR	• Pelco-P=1~255 • Pelco-D =1~255
3	Visca Address Fix	On/Off
4	Baud rate	2400/4800/9600/38400/115200
5	USB transmission mode	On/Off
6	Auto Flip	On/Off

Camera setting

Move the pointer to Camera in the main menu, then click the HOME key and enter CAMERA as follow.

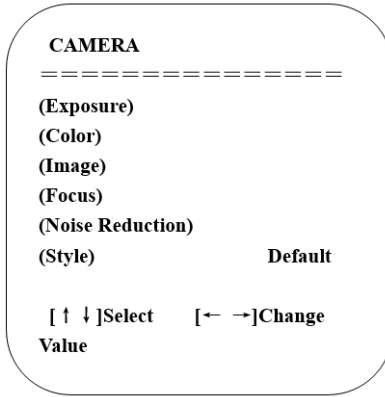

No.	Name	Descriptions
①	Exposure	Enter Exposure setting.
②	Color	Enter Color setting.
③	Image	Enter Image setting.
④	Focus	Enter Focus setting.
⑤	Noise Reduction	Enter Noise Reduction.
⑥	Style	Default, Normal, Clarity, Bright, and Soft.

1. Exposure setting

Move the pointer to Exposure in the main menu, then click the HOME key and enter EXPOSURE as follow.

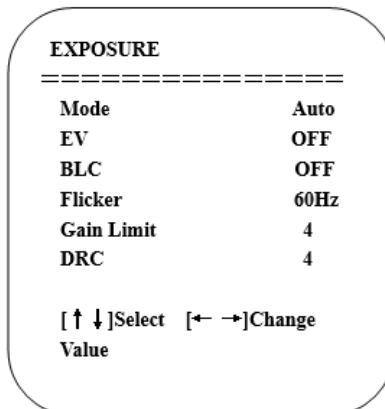

No.	Name	Descriptions
①	Mode	Auto, Manual, SAE, AAE, and Bright.
②	EV	On/Off (only available in Auto mode)
③	Compensation Level	-7~7 (only available in Auto mode when EV is ON)
④	BLC	ON/OFF for options (only available in Auto mode)
⑤	Flicker	OFF/50Hz/60Hz for options (only available in Auto/Iris priority/Brightness priority modes)
⑥	Gain Limit	0~15 (only available in Auto/ Iris priority / Brightness priority mode)
⑦	DRC	Off, 1~8
⑧	Shutter Priority	1/25,1/30,1/50,1/60,1/90,1/100,1/120,1/180,1/250,1/350,1/500,1/1000,1/2000,1/3000,1/4000,1/6000,1/10000 (only available in Manual and Shutter priority mode)
⑨	IRIS Priority	OFF,F11.0,F9.6,F8.0,F6.8,F5.6,F4.8,F4.0,F3.4,F2.8,F2.4,F2.0,F1.8 (only available in Manual and Iris priority mode)
⑩	Brightness	0~23 (only available in Brightness priority mode)

2. Color setting

Move the pointer to Color in the main menu, then click the HOME key and enter COLOR as follow.

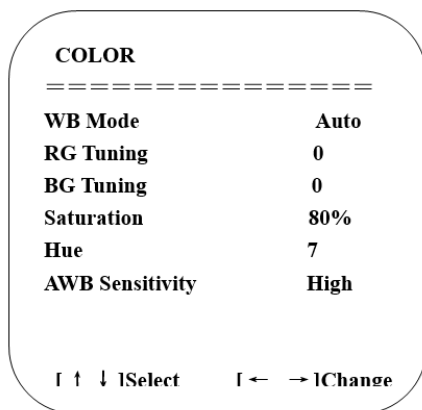

No.	Name	Descriptions
①	WB Mode	Auto, Manual, Onepush, and VAR
②	RG Tuning	Red Gain 0~255 (only available in Manual mode)
③	BG Tuning	Blue Gain 0~255 (only available in Manual mode)
④	Saturation	60% to 200%, adjustable intervals of 10%

5	Hue	0~14
6	AWB Sensitivity	High/Middle/Low

3. Image setting

Move the pointer to Image in the main menu, then click the HOME key and enter IMAGE as follow.

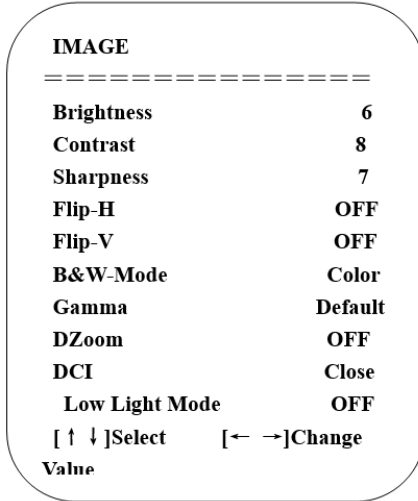

No.	Name	Descriptions
1	Brightness	0~14
2	Contrast	0~14
3	Sharpness	0~15
4	Flip-H	On/Off
5	Flip-V	On/Off
6	B&W Mode	Color, Black & White
7	Gamma	Default, 0.45, 0.50, 0.55, 0.63
8	DZoom	Digital zoom options: On/Off
9	DCI: Dynamic Contrast	Off, 1 ~ 8
10	Low light mode	On/Off

4. Focus setting

Move the pointer to Focus in the main menu, then click the HOME key and enter IMAGE as follow.

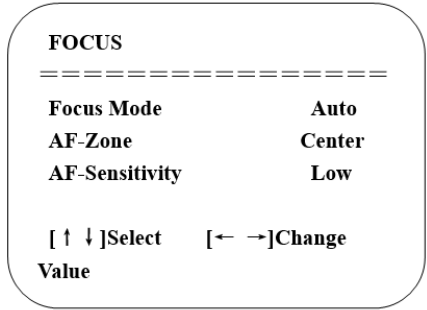

No.	Name	Descriptions
①	Focus Mode	Auto, Manual, One push
②	AF-Zone	All, Top, Center, Bottom
③	AF-Sensitivity	High, Middle, Low

5. Noise reduction setting

Move the pointer to Noise reduction in the main menu, then click the HOME key and enter NOISE REDUCTION as follow.

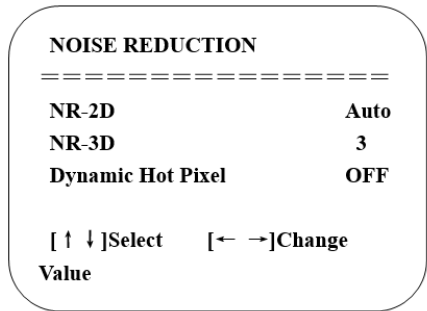

No.	Name	Descriptions
①	2D Noise Reduction	Auto, Off, 1~7
②	3D Noise Reduction	Off, 1~8
③	Dynamic Hot Pixel	Off, 1~5

P/T/Z

Move the pointer to P/T/Z in the main menu, then click the HOME key and enter P/T/Z as follow.

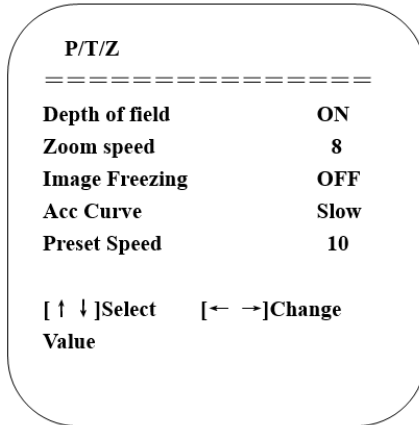

No.	Name	Descriptions
1	Depth of field	Only effective for remote control, On/ Off. When zoom in, the PT control speed by remote control will become slow.
2	Zoom speed	Set the zoom speed for remote control, 1~8
3	Image Freezing	On/Off
4	Accelerating Curve	Fast/Slow
5	Preset speed	1~10

Video Format

Move the pointer to Video Format in the main menu, then click the HOME key and enter VIDEO FORMAT as follow.

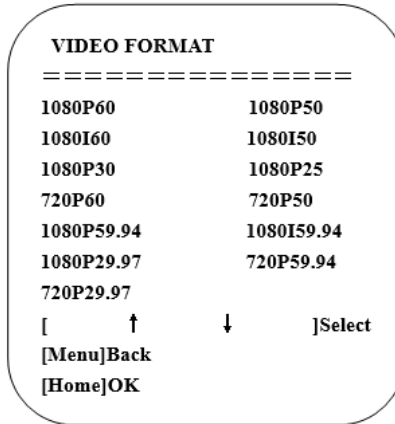

- 1080P60 Downward Compatibility.
- Exit the menu after modifying the parameter to save it after power off.

Version

Move the pointer to Version in the main menu, then click the HOME key and enter VERSION as follow.

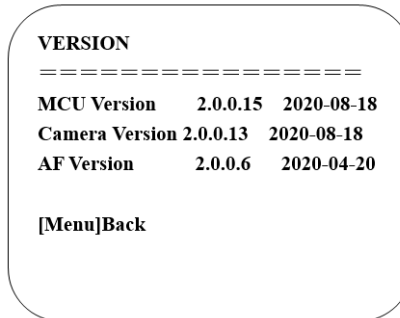

No.	Name	Descriptions
1	MCU Version	Display MCU version information.
2	Camera Version	Display Camera version information.
3	AF Version	Display the focus version information.

Restore Default

Move the pointer to Restore Default in the main menu, then click the HOME key and enter RESTORE DEFAULT as follow.

RESTORE DEFAULT

=====

Restore Default? NO

[↑ ↓]Select [← →]Change

Value

[Menu]Back [Home]OK

No.	Name	Descriptions
1	Restore default	Options: Yes/No; after restoring default, the video format won't be restored.
	If the address of the former remote control is not 1 but another one from 2,3,4, the corresponding camera address will restore to 1 when all parameters or system parameters are restored. Users should change the remote control's address to be 1 (press No.1 according to the camera so as to get normal operation).	

Network connection

Network connection: Connect products directly with PC external network ports by network wires or connect products to Internet network. Access network can be through routers or switches. Users can login product IP through browsers.

Caution: Do not place wires where they are easily touched, so as not to cause unstable signal transmission caused by poor line contact and affect video quality.

Adding segment method: The computer must add the network segment where the product IP is located. If the network segment is not added, it will be unable to log in and so on. The default IP address of the product is 192.168.5.163. Five network segments need to be added to the computer.



Adding an IP address does not conflict with other computers or products. Verify that this IP exists before adding it.

The specific process is as follows:

First, open the attributes window of local connection of computer network, double-click “Internet Protocol Version 4 (TCP/IPV4)” or point attribute “Internet Protocol Version 4 (TCP/IPV4)” and enter the attributes window of Internet Protocol Version 4 (TCP/IPV4). Click “Advanced” to enter the advanced TCP/IP settings, and add IP and IPv4 to the IP address bar. Subnet mask, add the completion point “confirm”, that is, complete the IP segment addition.

Users can add corresponding network segments according to their modified product IP address.

Verify the success of adding network segments. Open “Start” in the computer, select “Run” to enter cmd, click “OK” and open the DOS command window to enter Ping 192.168.5.26. Press the Enter key. The information appears as follows: Explain the success of adding network segments.

```

C:\Users\qq214>ping 192.168.5.163

Pinging 192.168.5.163 with 32 bytes of data:
Reply from 192.168.5.163: bytes=32 time=2ms TTL=64
Reply from 192.168.5.163: bytes=32 time=1ms TTL=64
Reply from 192.168.5.163: bytes=32 time=1ms TTL=64
Reply from 192.168.5.163: bytes=32 time=1ms TTL=64

Ping statistics for 192.168.5.163:
    Packets: Sent = 4, Received = 4, Lost = 0 (0% loss),
    Approximate round trip times in milli-seconds:
        Minimum = 1ms, Maximum = 2ms, Average = 1ms
  
```

After the product self-check is completed, the above steps can also be followed to verify whether the network is connected properly. If the default IP opens the DOS command window of the computer, input Ping 192.168.5.163 and press the Enter key, the information appears as follows: the network connection is normal.

```

Microsoft Windows [Version 10.0.10240]
(c) 2015 Microsoft Corporation. All rights reserved.

C:\Users\qq214>ping 192.168.5.153

Pinging 192.168.5.153 with 32 bytes of data:
Reply from 192.168.5.153: bytes=32 time=2ms TTL=128
Reply from 192.168.5.153: bytes=32 time=1ms TTL=128
Reply from 192.168.5.153: bytes=32 time=1ms TTL=128
Reply from 192.168.5.153: bytes=32 time=1ms TTL=128

Ping statistics for 192.168.5.153:
    Packets: Sent = 4, Received = 4, Lost = 0 (0% loss),
    Approximate round trip times in milli-seconds:
        Minimum = 1ms, Maximum = 2ms, Average = 1ms
  
```

IE login

Web client log in

Input the IP address 192.168.5.163 of the device in the address filed of browser and click Enter button to enter Web Client login page as below picture. User can login as administrator and normal user. If login as administrator (Default User name/Password: admin), users can preview, playback, configuration and cancel in the Web Client; If login in as normal user (Default User name/Password:user1 or user2),users can only preview, playback and cancel, no option for configuration.

Language selection: The upper right corner of the login interface shows “Chinese/English”; users can choose the language type of the web interface.



Web access supported browsers: IE,360 browser and other conventional browser.

If you need to preview images from non-IE core browsers such as Google, Opera, Firefox, Safari browser, you need to upgrade the plug-in program without video, width, sound, amplification, full screen, snapshot, playback and other functions.

Download/Install plug in

When first using IE browser to access the web conferencing camera, the login page will appear, “Playback plug-in is not installed, please download and install!” Click on this message, download and install “MRWebXinstall.exe” according to information prompts.

If a warning fails to download: Solution-- Browser > Tool > Internet Options > Security > Customization Level > Security Settings > Internet Area; check “ActiveX Control” and “Plug-in Directory” as enabled or prompted.

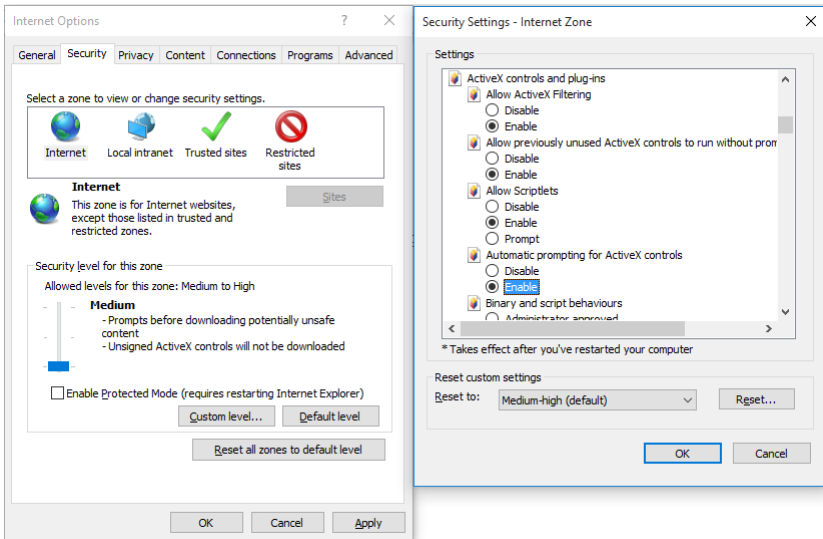

Web login

After installing the plug-in, enter the username and password, click login. Initial default username and password is “admin”. After logging in, you can change the username and password by yourself and enter the Web client management interface.

Streaming media

Getting Video Stream

Select Configuration > Video Configuration > Video Coding to enter the following interface.

Video Encode		
Stream	Main Stream	Sub Stream
Compressed Format	<input type="text" value="H.264"/>	<input type="text" value="H.264"/>
Profile	<input type="text" value="HP"/>	<input type="text" value="HP"/>
Image Size	<input type="text" value="1280*720"/>	<input type="text" value="320*180"/>
Rate Control	<input type="text" value="CBR"/>	<input type="text" value="CBR"/>
Image Quality	<input type="text" value="Best"/>	<input type="text" value="Good"/>
Bit Rate(Kb/S)	<input type="text" value="4096"/>	<input type="text" value="512"/>
Frame Rate(F/S)	<input type="text" value="25"/>	<input type="text" value="25"/>
I Frame Interval	<input type="text" value="75"/>	<input type="text" value="75"/>
I Frame Min QP	<input type="text" value="20"/>	<input type="text" value="20"/>
Stream Name	<input type="text" value="live/av0"/>	<input type="text" value="live/av1"/>

Configure parameters according to the network environment; note: stream name live/av0 (e.g. live/xxx)

If the default IP address of the camera is 192.168.5.163, the way to obtain the RTSP video stream is as follows:

rtsp://192.168.5.163:554/live/av0?av0 Main stream)

rtsp://192.168.5.163:554/live/av1?av1 Secondary bitstream)

If the default IP address of the camera is 192.168.5.163, the way to obtain RTMP video stream is as follows:

rtmp://192.168.5.163:1935/live/av0?av0Main stream)

rtmp://192.168.5.163:1935/live/av1?av1 Secondary bitstream)

Push Video Stream: Select Configuration > Video Configuration > Stream Publishing to enter the following interface.

Stream	Main Stream	Sub Stream
Enable	<input type="checkbox"/>	<input type="checkbox"/>
Protol Type	RTMP	RTMP
Host Address	192.168.5.11	192.168.5.11
Host Port	1935	1935
Stream Name	live/av0	live/av1
User Name		
Password		

To push RTMP audio and video streams to the server, the camera IP must be mapped to the external network, otherwise the connection to the server will be unsuccessful.

Host address: Server address, either domain name or IP address

Host Port: Server Default Port Number

Stream name: live/test (for example: live/xxx)

User name and password: User name and password are set by the server; if not set, can be left blank.

Access url: rtmp://server domain name address: server port number/live/xxx
Or (rtmp://server IP address: server port number/live/xxx)

Software upgrade

1. After successful login, it enters the management interface. By default, it enters the video preview interface. In the preview interface, you can control the platform, zoom, focus, video, snapshot, sound, amplification, full screen and preset settings, operation, deletion and other operations.
2. Select Configuration > System Configuration > Software Upgrade to enter the following interface.

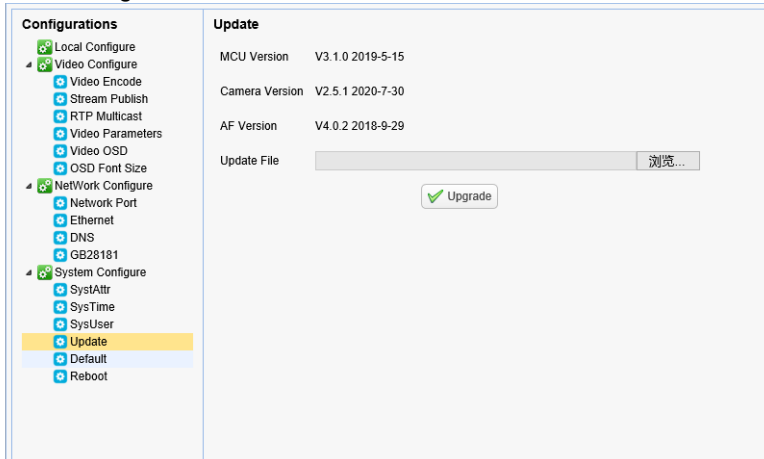

3. Click “Browse” to select the upgrade file “. mrg” and double-click, then click the “Upgrade” button to upgrade automatically.
4. Upgrade completed, product reboot and prompt “Upgrade Success”. Log on to the network, check whether the software version is consistent with the upgrade file to ensure the upgrade success, then click “Restore factory default” to restart and restore parameters to factory default (IP default 192.168.5.163, account admin, password admin).

Serial communication control

Under common working condition, the camera could be controlled through RS232/RS485 interface (VISCA); RS232C serial parameter are as follows:

Baud rate: 2400/4800/9600/115200 bits / sec; Start bit: 1; data bits: 8; Stop bit: 1; Parity: None.

After power on, the camera first go left, then back to the middle position. Self-test is finished after the zoom moved to the farthest and then back to the nearest position. If the camera saved 0 preset before, it will be back to that position after initialization. At this point, the user can control the camera by the serial commands.

VISCA protocol list

Camera return command

Ack/Completion Message		
	Command packet	Note
ACK	z0 41 FF	Returned when the command is accepted.
Completion	z0 51 FF	Returned when the command has been executed.

z = camera address + 8

Error Messages		
	Command packet	Note
Syntax Error	z0 60 02 FF	Returned when the command format is different or when a command with illegal command parameters is accepted.
Command Not Executable	z0 61 41 FF	Returned when a command cannot be executed due to current conditions. For example, when commands controlling the focus manually are received during auto focus.

VISCA Camera control command

Command	Function	Command packet	Note
AddressSet	Broadcast	88 30 0p FF	p: Address setting
IF_Clear	Broadcast	88 01 00 01 FF	I/F Clear
CommandCancel		8x 21 FF	
CAM_Power	On	8x 01 04 00 02 FF	Power ON/OFF
	Off	8x 01 04 00 03 FF	
CAM_Zoom	Stop	8x 01 04 07 00 FF	
	Tele (Standard)	8x 01 04 07 02 FF	
	Wide (Standard)	8x 01 04 07 03 FF	
	Tele (Variable)	8x 01 04 07 2p FF	p = 0(low) - 7(high)
	Wide (Variable)	8x 01 04 07 3p FF	
	Direct	8x 01 04 47 0p 0q 0r 0s FF	pqrs: Zoom Position
CAM_Focus	Stop	8x 01 04 08 00 FF	
	Far (Standard)	8x 01 04 08 02 FF	
	Near (Standard)	8x 01 04 08 03 FF	
	Far (Variable)	8x 01 04 08 2p FF	p = 0(low) - 7(high)
	Near (Variable)	8x 01 04 08 3p FF	
	Direct	8x 01 04 48 0p 0q 0r 0s FF	pqrs: Focus Position
	Auto Focus	8x 01 04 38 02 FF	
	One Push Mode	8x 01 04 38 04 FF	
Manual Focus	8x 01 04 38 03 FF		
CAM_Zoom Focus	Direct	8x 01 04 47 0p 0q 0r 0s 0t 0u 0v 0w FF	pqrs: Zoom Position tuvw: Focus Position

Command	Function	Command packet	Note
CAM_AFSensitivity	High	8x 01 04 58 01 FF	Focus sensitivity Setting
	Normal	8x 01 04 58 02 FF	
	Low	8x 01 04 58 03 FF	
CAM_AFZone	Top	8x 01 04 AA 00 FF	Focus Region Setting
	Center	8x 01 04 AA 01 FF	
	Bottom	8x 01 04 AA 02 FF	
	All	8x 01 04 AA 03 FF	
CAM_WB	Auto	8x 01 04 35 00 FF	
	3000K	8x 01 04 35 01 FF	
	4000k	8x 01 04 35 02 FF	
	One Push mode	8x 01 04 35 03 FF	
	5000k	8x 01 04 35 04 FF	
	Manual	8x 01 04 35 05 FF	
	6500k	8x 01 04 35 06 FF	
	3500K	8x 01 04 35 07 FF	
	4500K	8x 01 04 35 08 FF	
	5500K	8x 01 04 35 09 FF	
	6000K	8x 01 04 35 0A FF	
	7000K	8x 01 04 35 0B FF	
CAM_AWBSensitivity	Low	8x 01 04 A9 00 FF	WB Sensitivity Setting
	Normal	8x 01 04 A9 01 FF	
	High	8x 01 04 A9 02 FF	

Command	Function	Command packet	Note
CAM_RGain	Reset	8x 01 04 03 00 FF	Manual Control of R Gain
	Up	8x 01 04 03 02 FF	
	Down	8x 01 04 03 03 FF	
	Direct	8x 01 04 43 00 00 0p 0q FF	pq: R Gain
CAM_Bgain	Reset	8x 01 04 04 00 FF	Manual Control of R Gain
	Up	8x 01 04 04 02 FF	
	Down	8x 01 04 04 03 FF	
	Direct	8x 01 04 44 00 00 0p 0q FF	pq: B Gain
CAM_AE	Full Auto	8x 01 04 39 00 FF	Automatic Exposure mode
	Manual	8x 01 04 39 03 FF	Manual Control mode
	Shutter priority	8x 01 04 39 0A FF	Shutter Priority Automatic Exposure mode
	Iris priority	8x 01 04 39 0B FF	Iris Priority Automatic Exposure mode
	Bright	8x 01 04 39 0D FF	Bright mode
CAM_Shutter	Reset	8x 01 04 0A 00 FF	Shutter Setting
	Up	8x 01 04 0A 02 FF	
	Down	8x 01 04 0A 03 FF	
	Direct	8x 01 04 4A 00 00 0p 0q FF	pq: Shutter Position

Command	Function	Command packet	Note
CAM_Iris	Reset	8x 01 04 0B 00 FF	Iris Setting
	Up	8x 01 04 0B 02 FF	
	Down	8x 01 04 0B 03 FF	
	Direct	8x 01 04 4B 00 00 0p 0q FF	pq: Iris Position
CAM_Gain Limit	Reset	8x 01 04 0C 00 FF	Gain Limit Setting
	Up	8x 01 04 0C 02 FF	
	Down	8x 01 04 0C 03 FF	
	Gain Limit	8x 01 04 2C 0p FF	p: Gain Position
CAM_Bright	Reset	8x 01 04 0D 00 FF	Bright Setting
	Up	8x 01 04 0D 02 FF	
	Down	8x 01 04 0D 03 FF	
	Direct	8x 01 04 4D 00 00 0p 0q FF	pq: Bright Position
CAM_ExpComp	On	8x 01 04 3E 02 FF	Exposure Compensation ON/OFF
	Off	8x 01 04 3E 03 FF	
	Reset	8x 01 04 0E 00 FF	Exposure Compensation Amount Setting
	Up	8x 01 04 0E 02 FF	
	Down	8x 01 04 0E 03 FF	
	Direct	8x 01 04 4E 00 00 0p 0q FF	pq: ExpComp Position
CAM_Back Light	On	8x 01 04 33 02 FF	Back Light Compensation
	Off	8x 01 04 33 03 FF	

Command	Function	Command packet	Note
 VISCA has no DRCcommand; leverage WDR to adjust DRC parameter.	Reset	8x 01 04 21 00 FF	WDR Level Setting
	Up	8x 01 04 21 02 FF	
	Down	8x 01 04 21 03 FF	
	Direct	8x 01 04 51 00 00 00 0p FF	p: WDR Level Position
CAM_NR (2D)		8x 01 04 53 0p FF	P=0-7 0:OFF
CAM_NR (3D)		8x 01 04 54 0p FF	P=0-8 0:OFF
CAM_Gamma		8x 01 04 5B 0p FF	p = 0 – 4 0:Default 1:0.45 2:0.50 3:0.52 4:0.63
CAM_Low-Light Mode	ON	8x 01 04 2D 01 FF	Low-Light Mode Setting
	OFF	8x 01 04 2D 00 FF	
CAM_Flicker	OFF	8x 01 04 23 00 FF	OFF
	50HZ	8x 01 04 23 01 FF	50HZ
	60HZ	8x 01 04 23 02 FF	60HZ
CAM_Aperture	Reset	8x 01 04 02 00 FF	Aperture Control
	Up	8x 01 04 02 02 FF	
	Down	8x 01 04 02 03 FF	
	Direct	8x 01 04 42 00 00 0p 0q FF	pq: Aperture Gain
CAM_Picture effect	B&W-Mode	8x 01 04 63 04 FF	Picture effect Setting
	OFF	8x 01 04 63 00 FF	
CAM_Memory	Reset	8x 01 04 3F 00 pq FF	pq: Memory Number(=0 to 254) Corresponds to 0 to 9 on the Remote Commander
	Set	8x 01 04 3F 01 pq FF	
	Recall	8x 01 04 3F 02 pq FF	

Command	Function	Command packet	Note
CAM_LR_Reverse	On	8x 01 04 61 02 FF	Image Flip Horizontal ON/ OFF
	Off	8x 01 04 61 03 FF	
CAM_PictureFlip	On	8x 01 04 66 02 FF	Image Flip Vertical ON/OFF
	Off	8x 01 04 66 03 FF	
CAM_ColorSaturation	Direct	8x 01 04 49 00 00 00 0p FF	P=0-7 0:60% 1:70% 2:80% 3:90% 4:100% 5:110% 6:120% 7:130% 8:140% 9:150% A:160% B:160% C:180% D:190% E:200%
CAM_IDWrite		8x 01 04 22 0p 0q 0r 0s FF	pqrs: Camera ID (=0000 to FFFF)
SYS_Menu	On	8x 01 04 06 06 02 FF	Turn on the menu screen.
	Off	8x 01 04 06 06 03 FF	Turn off the menu screen.
IR_Receive	On	8x 01 06 08 02 FF	IR (remote commander) receive On/Off.
	Off	8x 01 06 08 03 FF	
IR_ReceiveReturn	On	8x 01 7D 01 03 00 00 FF	IR (remote commander) receive message via the VISCA communication ON/OFF.
	Off	8x 01 7D 01 13 00 00 FF	
CAM_SettingReset	Reset	8x 01 04 A0 10 FF	Reset Factory Setting
CAM_Brightness	Direct	8x 01 04 A1 00 00 0p 0q FF	pq: Brightness Position
CAM_Contrast	Direct	8x 01 04 A2 00 00 0p 0q FF	pq: Contrast Position

Command	Function	Command packet	Note
CAM_Flip	OFF	8x 01 04 A4 00 FF	Single Command For Video Flip
	Flip-H	8x 01 04 A4 01 FF	
	Flip-V	8x 01 04 A4 02 FF	
	Flip-HV	8x 01 04 A4 03 FF	
CAM_VideoSystem	Set camera video system	8x 01 06 35 00 0p FF	P: 0~E Video format 0: 1080P60 1: 1080P50 2: 1080i60 3: 1080i50 4: 720P60 5: 720P50 6: 1080P30 7: 1080P25 8: 720P30 9: 720P25 A: 1080P59.94 B: 1080i59.94 C: 720P59.94 D: 1080P29.97 E: 720P29.97

Command	Function	Command packet	Note
Pan_tiltDrive	Up	8x 01 06 01 VV WW 03 01 FF	VV: Pan speed 0x01 (low speed) to 0x18 (high speed) WW: Tilt speed 0x01 (low speed) to 0x14 (high speed) YYYY: Pan Position ZZZZ: Tilt Position
	Down	8x 01 06 01 VV WW 03 02 FF	
	Left	8x 01 06 01 VV WW 01 03 FF	
	Right	8x 01 06 01 VV WW 02 03 FF	
	Upleft	8x 01 06 01 VV WW 01 01 FF	
	Upright	8x 01 06 01 VV WW 02 01 FF	
	DownLeft	8x 01 06 01 VV WW 01 02 FF	
	DownRight	8x 01 06 01 VV WW 02 02 FF	
	Stop	8x 01 06 01 VV WW 03 03 FF	
Pan_tiltDrive	Absolute Position	8x 01 06 02 VV WW 0Y 0Y 0Y 0Y 0Z 0Z 0Z 0Z FF	VV: Pan speed 0x01 (low speed) to 0x18 (high speed) WW: Tilt speed 0x01 (low speed) to 0x14 (high speed) YYYY: Pan Position ZZZZ: Tilt Position
	Relative Position	8x 01 06 03 VV WW 0Y 0Y 0Y 0Y 0Z 0Z 0Z 0Z FF	
	Home	8x 01 06 04 FF	
	Reset	8x 01 06 05 FF	
Pan-tiltLimitSet	Set	8x 01 06 07 00 0W 0Y 0Y 0Y 0Y 0Z 0Z 0Z 0Z FF	W:I UpRight 0:DownLeft YYYY: Pan Limit Position (TBD) ZZZZ: Tilt Limit Position (TBD)
	Clear	8x 01 06 07 01 0W 07 0F 0F 0F 0F 0F 0F FF	

VISCA Inquiry command

Command	Function	Command packet	Note
CAM_PowerInq	8x 09 04 00 FF	y0 50 02 FF	On
		y0 50 03 FF	Off (Standby)
CAM_ZoomPosInq	8x 09 04 47 FF	y0 50 0p 0q 0r 0s FF	pqrs: Zoom Position
CAM_FocusAFModelInq	8x 09 04 38 FF	y0 50 02 FF	Auto Focus
		y0 50 03 FF	Manual Focus
		y0 50 04 FF	One Push mode
CAM_FocusPosInq	8x 09 04 48 FF	y0 50 0p 0q 0r 0s FF	pqrs: Focus Position
CAM_AFSensitivityInq	8x 09 04 58 FF	y0 50 01 FF	High
		y0 50 02 FF	Normal
		y0 50 03 FF	Low
CAM_AFZoneInq	8x 09 04 AA FF	y0 50 00 FF	Top
		y0 50 01 FF	Center
		y0 50 02 FF	Bottom
		y0 50 03 FF	All

Command	Function	Command packet	Note
CAM_WBModelInq	8x 09 04 35 FF	y0 50 00 FF	Auto
		y0 50 01 FF	3000K
		y0 50 02 FF	4000K
		y0 50 03 FF	One Push Mode
		y0 50 04 FF	5000K
		y0 50 05 FF	ManualManual
		y0 50 06 FF	6500K
		y0 50 07 FF	3500K
		y0 50 08 FF	4500K
		y0 50 09 FF	5500K
		y0 50 0A FF	6000K
		y0 50 0B FF	7000K
CAM_AWBSensitivityInq	8x 09 04 A9 FF	y0 50 00 FF	Low
		y0 50 01 FF	Normal
		y0 50 02 FF	High
CAM_RGainInq	8x 09 04 43 FF	y0 50 00 00 0p 0q FF	pq: R Gain
CAM_BGainInq	8x 09 04 44 FF	y0 50 00 00 0p 0q FF	pq: B Gain
CAM_AEModelInq	8x 09 04 39 FF	y0 50 00 FF	Full Auto
		y0 50 03 FF	Manual
		y0 50 0A FF	Shutter priority
		y0 50 0B FF	Iris priority
		y0 50 0D FF	Bright
CAM_ShutterPosInq	8x 09 04 4A FF	y0 50 00 00 0p 0q FF	pq: Shutter Position

Command	Function	Command packet	Note
CAM_IrisPosInq	8x 09 04 4B FF	y0 50 00 00 0p 0q FF	pq: Iris Position
CAM_Gain LimitInq	8x 09 04 2C FF	y0 50 0p FF	p: Gain Position
CAM_BrightPosInq	8x 09 04 4D FF	y0 50 00 00 0p 0q FF	pq: Bright Position
CAM_ExpCompModelInq	8x 09 04 3E FF	y0 50 02 FF	On
		y0 50 03 FF	Off
CAM_ExpCompPosInq	8x 09 04 4E FF	y0 50 00 00 0p 0q FF	pq: ExpComp Position
CAM_BacklightModelInq	8x 09 04 33 FF	y0 50 02 FF	On
		y0 50 03 FF	Off
CAM_WDRStrengthInq  VISCA has no DRCcommand; leverage WDR to adjust DRC parameter.	8x 09 04 51 FF	y0 50 0p FF	p: WDR Strength
CAM_NRLevel(2D) Inq	8x 09 04 53 FF	y0 50 0p FF	P: 2DNRLLevel
CAM_NRLevel(3D) Inq	8x 09 04 54 FF	y0 50 0p FF	P: 3D NRLevel
CAM_FlickerModelInq	8x 09 04 55 FF	y0 50 0p FF	p: Flicker Settings (0: OFF;1: 50Hz,2:60Hz)
CAM_ApertureInq	8x 09 04 42 FF	y0 50 00 00 0p 0q FF	pq: Aperture Gain
CAM_PictureEffectModelInq	8x 09 04 63 FF	y0 50 00 FF	Off
		y0 50 04 FF	B&W
CAM_MemoryInq	8x 09 04 3F FF	y0 50 0p FF	p: Memory number last operated.

Command	Function	Command packet	Note
SYS_MenuModelInq	8x 09 06 06 FF	y0 50 02 FF	On
		y0 50 03 FF	Off
CAM_LR_ReverseInq	8x 09 04 61 FF	y0 50 02 FF	On
		y0 50 03 FF	Off
CAM_PictureFlipInq	8x 09 04 66 FF	y0 50 02 FF	On
		y0 50 03 FF	Off
CAM_ColorSaturationInq	8x 09 04 49 FF	y0 50 00 00 00 0p FF	p: Color Gain setting 0h (60%) to Eh (130%)
CAM_IDInq	8x 09 04 22 FF	y0 50 0p FF	p: Gamma ID
IR_ReceiveInq	8x 09 06 08 FF	y0 50 02 FF	On
		y0 50 03 FF	Off
CAM_BrightnessInq	8x 09 04 A1 FF	y0 50 00 00 0p 0q FF	pq: Brightness Position
CAM_ContrastInq	8x 09 04 A2 FF	y0 50 00 00 0p 0q FF	pq: Contrast Position
CAM_FlipInq	8x 09 04 A4 FF	y0 50 00 FF	Off
		y0 50 01 FF	Flip-H
		y0 50 02 FF	Flip-V
		y0 50 03 FF	Flip-HV
CAM_GammaInq	8x 09 04 5B FF	y0 50 0p FF	p: Gamma setting
CAM_VersionInq	8x 09 00 02 FF	y0 50 ab cd mn pq rs tu vw FF	ab cd: vender ID (0220) mn pq : model ID ST rs tu: ARM Version vw: reserve

Command	Function	Command packet	Note
CAM_Low-LightModelInq	8x 09 04 2D FF	y0 50 00 FF	OFF
		y0 50 01 FF	ON
VideoSystemInq	8x 09 06 23 FF	y0 50 0p FF	P: 0~E Video format 0:1080P60 1:1080P50 2:1080i60 3:1080i50 4:720P60 5:720P50 6:1080P30 7:1080P25 8:720P30 9:720P25 A:1080P59.94 B:1080i59.94 C:720P59.94 D:1080P29.97 E:720P29.97
Pan-tiltMaxSpeedInq	8x 09 06 11 FF	y0 50 ww zz FF	ww: Pan Max Speed zz: Tilt Max Speed
Pan-tiltPosInq	8x 09 06 12 FF	y0 50 0w 0w 0w 0w 0z 0z 0z 0z FF	www: Pan Position zzzz: Tilt Position

[X] in the above table indicates the camera address to be operated, $y = x + 8$.

Pelco-D protocol command list

Function	Byte1	Byte2	Byte3	Byte4	Byte5	Byte6	Byte7
Up	0xFF	Address	0x00	0x08	Pan Speed	Tilt Speed	SUM
Down	0xFF	Address	0x00	0x10	Pan Speed	Tilt Speed	SUM
Left	0xFF	Address	0x00	0x04	Pan Speed	Tilt Speed	SUM
Right	0xFF	Address	0x00	0x02	Pan Speed	Tilt Speed	SUM
Upleft	0xFF	Address	0x00	0x0C	Pan Speed	Tilt Speed	SUM
Upright	0xFF	Address	0x00	0x0A	Pan Speed	Tilt Speed	SUM

Function	Byte1	Byte2	Byte3	Byte4	Byte5	Byte6	Byte7
DownLeft	0xFF	Address	0x00	0x14	Pan Speed	Tilt Speed	SUM
DownRight	0xFF	Address	0x00	0x12	Pan Speed	Tilt Speed	SUM
Zoom In	0xFF	Address	0x00	0x20	0x00	0x00	SUM
Zoom Out	0xFF	Address	0x00	0x40	0x00	0x00	SUM
Focus Far	0xFF	Address	0x00	0x80	0x00	0x00	SUM
Focus Near	0xFF	Address	0x01	0x00	0x00	0x00	SUM
Set Preset	0xFF	Address	0x00	0x03	0x00	Preset ID	SUM
Clear Preset	0xFF	Address	0x00	0x05	0x00	Preset ID	SUM
Call Preset	0xFF	Address	0x00	0x07	0x00	Preset ID	SUM
Query Pan Position	0xFF	Address	0x00	0x51	0x00	0x00	SUM
Query Pan Position Response	0xFF	Address	0x00	0x59	Value High Byte	Value Low Byte	SUM
Query Tilt Position	0xFF	Address	0x00	0x53	0x00	0x00	SUM
Query Tilt Position Response	0xFF	Address	0x00	0x5B	Value High Byte	Value Low Byte	SUM
Query Zoom Position	0xFF	Address	0x00	0x55	0x00	0x00	SUM
Query Zoom Position Response	0xFF	Address	0x00	0x5D	Value High Byte	Value Low Byte	SUM

Pelco-P protocol command list

Function	Byte1	Byte2	Byte3	Byte4	Byte5	Byte6	Byte7	Byte8
Up	0xA0	Address	0x00	0x08	Pan Speed	Tilt Speed	0xAF	XOR

Function	Byte1	Byte2	Byte3	Byte4	Byte5	Byte6	Byte7	Byte8
Down	0xA0	Address	0x00	0x10	Pan Speed	Tilt Speed	0xAF	XOR
Left	0xA0	Address	0x00	0x04	Pan Speed	Tilt Speed	0xAF	XOR
Right	0xA0	Address	0x00	0x02	Pan Speed	Tilt Speed	0xAF	XOR
Upleft	0xA0	Address	0x00	0x0C	Pan Speed	Tilt Speed	0xAF	XOR
Upright	0xA0	Address	0x00	0x0A	Pan Speed	Tilt Speed	0xAF	XOR
DownLeft	0xA0	Address	0x00	0x14	Pan Speed	Tilt Speed	0xAF	XOR
DownRight	0xA0	Address	0x00	0x12	Pan Speed	Tilt Speed	0xAF	XOR
Zoom In	0xA0	Address	0x00	0x20	0x00	0x00	0xAF	XOR
Zoom Out	0xA0	Address	0x00	0x40	0x00	0x00	0xAF	XOR
Focus Far	0xA0	Address	0x01	0x00	0x00	0x00	0xAF	XOR
Focus Near	0xA0	Address	0x02	0x00	0x00	0x00	0xAF	XOR
Set Preset	0xA0	Address	0x00	0x03	0x00	Preset ID	0xAF	XOR
Clear Preset	0xA0	Address	0x00	0x05	0x00	Preset ID	0xAF	XOR
Call Preset	0xA0	Address	0x00	0x07	0x00	Preset ID	0xAF	XOR
Query Pan Position	0xA0	Address	0x00	0x51	0x00	0x00	0xAF	XOR
Query Pan Position Response	0xA0	Address	0x00	0x59	Value High Byte	Value Low Byte	0xAF	XOR
Query Tilt Position	0xA0	Address	0x00	0x53	0x00	0x00	0xAF	XOR
Query Tilt Position Response	0xA0	Address	0x00	0x5B	Value High Byte	Value Low Byte	0xAF	XOR
Query Zoom Position	0xA0	Address	0x00	0x55	0x00	0x00	0xAF	XOR

Function	Byte1	Byte2	Byte3	Byte4	Byte5	Byte6	Byte7	Byte8
Query Zoom Position Response	0xA0	Address	0x00	0x5D	Value High Byte	Value Low Byte	0xAF	XOR

Product information

Specifications

Item		Specifications
		DVY23
Camera Parameter	Optical zoom	20X, f=5.5~110mm
	Sensor	1/2.8 inch high quality HD CMOS sensor
	Effective pixels	16:9, 2.07 megapixel
	Video format	HDMI/SDI video format 1080P60, 1080P50, 1080I60, 1080I50, 1080P30, 1080P25, 720P60, 720P50 “P”: progressive scan format image. “i”: interlaced scan format image. USB3.0 interface video format: Master stream: YUY2/MJPEG/NV12/H.264/ H.265 supports 1920×1080P30, 1280×720P30, 1024×576P30, 960×540P30, 800×448P30, 720×480P30, 640×360P30, 640×480P30, 320×176P30 Slave stream: YUY2/NV12 supports 640×360P30, 640×480P30, 320×176P30 MJPEG/H.264 supports 1920×1080P30, 1280×720P30, 1024×576P30, 960×540P30, 800×448P30, 720×480P30, 640×360P30, 640×480P30, 320×176P30
	View angle	63°(D)/55°(H)/31°(V)
	AV	F1.6 - F3.5
	Digital zoom	10X
	Minimum illumination	0.5Lux (F1.8, AGC ON)
	Minimum object distance	50mm (Wide end), 100mm (Tele end)
	DNR	2D & 3D DNR
	White balance	Auto / Manual/ One Push/ 3000K/3500K/4000K/ 4500K/5000K/5500K/6000K/6500K/7000K
	Focus/Aperture/ Electronic Shutter	Auto/Manual/One Push Focus
	Iris	Auto/Manual
	Shutter	Auto/Manual
	BLC	ON/OFF
	DRC	OFF/ Dynamic level adjustment
	Video adjustment	Brightness, Color, Saturation, Contrast, Sharpness, B/W mode, Gamma curve
SNR	>50dB	

Input/Output Interface	Video interfaces	HDMI, LAN (POE), USB3.0 (Type B compatible USB2.0), SDI, A-IN, RS232-IN, RS232-OUT, RS422 (compatible with RS485), Dial Code, Power Switch
	Video output	HDMI, SDI, LAN, USB3.0
	Video stream	Dual stream output
	Video compression format	LAN Interface: H.265, H.264, Dual stream output USB3.0 Interface: YUY2, MJPEG, H.264, NV12, H.265, Dual stream output
	Audio input interface	Double track 3.5mm linear input
	Audio output interface	HDMI, SDI, LAN, USB3.0
	Audio compression format	AAC
	Network protocol	RTSP, RTMP, ONVIF, GB/T28181, VISCA OVER IP, IP VISCA, RTMPS, SRT Support remote upgrade, remote restart, remote reset
	Control interface	RS232, RS422, RS485
	Control protocol	VISCA/Pelco-D/Pelco-P, Baud Rate: 115200/9600/4800/2400bps
	Power interface	HEC3800 outlet (DC12V)
	Input voltage	DC12V
	Input electric current	Maximum: 1.5A
	Power consumption	Maximum: 18W
PTZ Parameter	Pan/Tilt rotation	$\pm 170^{\circ}$, $-30^{\circ} \sim +90^{\circ}$
	Pan control speed	0.1-100°/sec
	Tilt control speed	0.1-45°/sec
	Preset speed	Pan: 100° sec, Tilt: 30° sec
	Preset number	255 presets (10 presets by remote control)
Other Parameter	Stored temperature	-10°C ~ 60°C
	Storage humidity	20%~95%
	Working temperature	-10°C ~ 45°C
	Working humidity	20% ~ 80%
	Dimension	178mm x 115.5mm x 150.9mm
Weight	1.38KG	
Attachment	Package	12V/1.5A Power supply, RS232 control cable, USB3.0 cable, Remote Control
	Accessories optional	Mounting (optional)

Dimensions

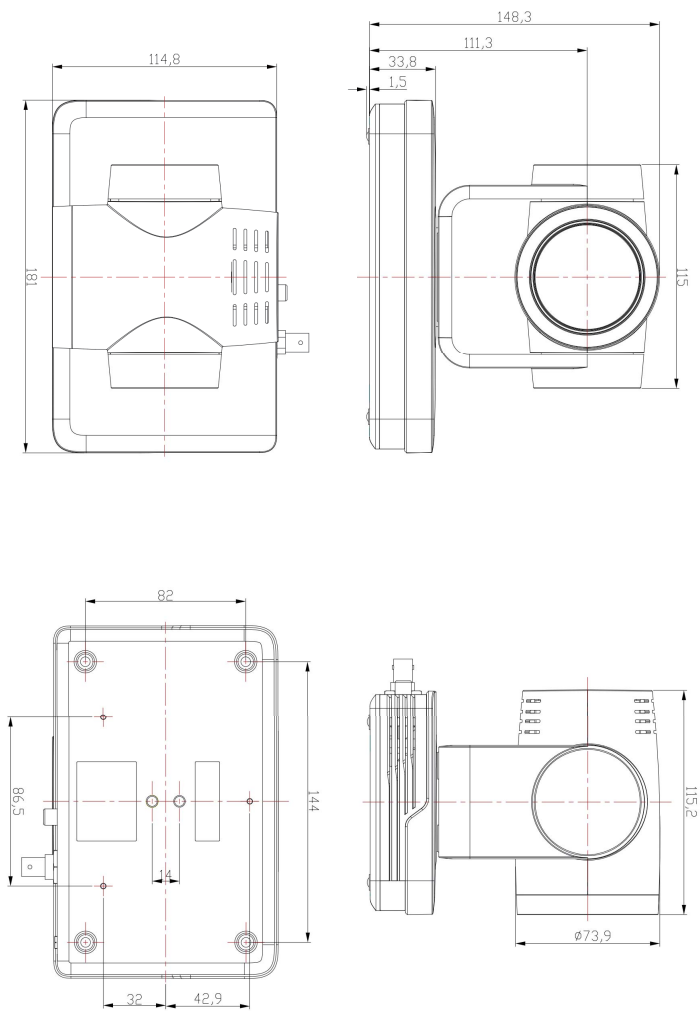

Unit: mm

Maintenance and troubleshooting

Maintenance

1. If the equipment is not in long-term use, disconnect the power switch when not in use and disconnect the AC power adapter from the AC socket.
2. When removing dust from the outer shell of the equipment, please use soft cloth or cotton paper to avoid scratches.
3. When cleaning equipment lens, please use dry soft cloth to wipe. If the equipment is heavily soiled, please use neutral detergent to wipe gently. Do not use strong or corrosive detergents to avoid lens scratches and affect image effects.

Troubleshooting

1. Video output without image:
 - Check whether the power supply of the equipment is properly connected and whether the power indicator is on.
 - Whether the power-off restart equipment is normal or not.
 - Check whether the bottom dial switch is working in normal mode.
 - Check whether the connection of video output and video display is normal.
2. Images are sometimes absent: Check whether the connection of video output and video display is normal.
3. Lens zoom image jitter:
 - Check whether the installation position of the equipment is firm or not.
 - Check whether there are vibrating machines or objects around the equipment.
4. Remote control is uncontrollable:
 - Check whether the remote control address is set to I controllable (if the equipment restores to the factory default value, the remote control address is also restored to I).
 - Check whether the remote control battery is installed properly or the power supply is insufficient.
 - Check whether the working mode of the equipment is normal.
 - Check whether the menu has not exited; it can be controlled normally after exiting the menu. If the page outputs images, it will not display the menu and do nothing. After 30 seconds, the menu automatically exits and can be controlled.
5. Serial port can't be controlled:
 - Make sure the serial port is well connected by the company cable.
 - Make sure the protocol, baud rate and address of serial devices are consistent with the equipment.
 - Check whether the control line is connected properly.
6. Web pages cannot be logged in:
 - Check whether the equipment is working properly with the display.
 - Check whether the network connection is normal (the yellow indicator flashes at the outlet, indicating that the network connection is normal).
 - Check whether the computer adds a network segment and the network segment is identical to the device IP address.

- Open “Start” in the computer, select “Run” and enter cmd; click “OK” and then open the computer DOS command window and enter Ping 192.168.5.163. Press the Enter key and the information appears as follows: Describe the network connection.

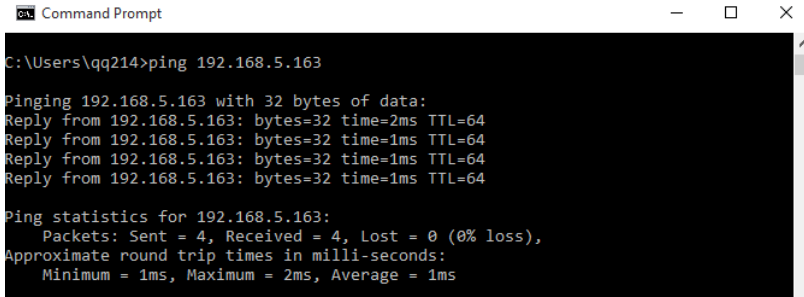

```
Command Prompt
C:\Users\qq214>ping 192.168.5.163

Pinging 192.168.5.163 with 32 bytes of data:
Reply from 192.168.5.163: bytes=32 time=2ms TTL=64
Reply from 192.168.5.163: bytes=32 time=1ms TTL=64
Reply from 192.168.5.163: bytes=32 time=1ms TTL=64
Reply from 192.168.5.163: bytes=32 time=1ms TTL=64

Ping statistics for 192.168.5.163:
    Packets: Sent = 4, Received = 4, Lost = 0 (0% loss),
    Approximate round trip times in milli-seconds:
        Minimum = 1ms, Maximum = 2ms, Average = 1ms
```