



Questo manuale d'istruzione è fornito da trovaprezzi.it. Scopri tutte le offerte per [Bixolon XD3-40t](#) o cerca il tuo prodotto tra le [migliori offerte di Macchine per Ufficio](#)



Questo manuale d'istruzione è fornito da trovaprezzi.it. Scopri tutte le offerte per [Bixolon XD3-40t](#) o cerca il tuo prodotto tra le [migliori offerte di Macchine per Ufficio](#)

BIXOLON®

User's Manual

XD3-40t Series

THERMAL TRANSFER LABEL PRINTER
Ver. 1.01



<http://www.bixolon.com>

Introduction

XD3-40t series printers have been designed to be connected to various types of electronic devices such as computer peripheral devices.

※ The main features of the printer are as follows

1. Maximum 127mm/s printing speed.
2. 4inch THERMAL TRANSFER LABEL PRINTER
3. 210 x 284 x 186 (W x D x H)
4. Support for multiple interfaces (Standard: USB, Option: USB & Serial & Ethernet)
5. Easy media loading
6. Can print a range of barcodes
7. Supporting peeler option

It is advisable to read the contents of this manual carefully before using the printer for the first time.

※ Use only authorized supplies that can be trusted!

- We are not responsible for quality and service for damage caused by the use of unauthorized products (or recycled ones).

Safety Information

 **Warning:** Warnings must be heeded carefully in order to prevent serious physical harm.

 **Caution:** Cautions must be heeded in order to prevent minor injuries, equipment damage, or data loss.

Symbol Information





	DC (Direct current)
	Warning, Caution
	USB
	Ethernet

Table of Contents

Copyright	6
1. Content Confirmation	11
2. Product Part Names	12
3. Installation & Usage	14
3-1 Printer Installation Placings	14
3-2 Power Connection	15
3-3 Interface.....	17
3-3-1 Standard Interface(USB only)	18
3-3-2 Option Interface(USB & Serial & Ethernet)	19
3-4 Media Installation	20
3-5 Ribbon Installation	22
3-5-1 Type of Ribbon.....	22
3-5-2 Inserting a One-Inch Core Ribbon	23
3-5-3 Inserting a Half-Inch Core Ribbon.....	24
3-5-4 Knob Adjust Method According to Ribbon Length.....	25
3-5-5 Narrow Ribbon Installation	26
3-5-6 Ribbon Removal.....	26
3-5-7 Ribbon Sensor Activation	26
3-6 Control Panel.....	27
3-7 Feed/Pause Button Operations.....	28
4. Self-test	29
5. Detailed features	30
5-1 Stand-alone Configuration Mode	30
5-1-1 Start Stand-alone Configuration Mode and execute each function.....	30
5-1-2 Function List of Stand-alone Configuration Mode	30
5-2 Media Length Measurement	31
5-3 Pause/Resume	31
5-4 Gap Sensor Auto Calibration Mode	31
5-5 Black Mark Sensor Auto Calibration Mode	32
5-6 Media Sensor Manual Calibration.....	33
5-7 Data Dump Mode	34
5-8 Media Installation Method of Peeler(Optional) Model.....	35
5-9 Using Fan-Fold or External Media.....	37
5-9-1 Printer Preparation	37
5-9-2 When using Fan-Fold Media.....	38
5-9-3 When using Large-Capacity Media Roll(Optional).....	39
6. Printer maintenance	40

6-1 Cleaning Head..... 40
6-2 Cleaning Sensors, Roller or/and Media Path..... 41
6-3 Replacing Roller 42
7. Appendix.....43
7-1 Specifications 43
7-2 Label Types..... 43

Copyright

© BIXOLON Co., Ltd. All rights reserved.

This user manual and all property of the product are protected under copyright law. It is strictly prohibited to copy, store, and transmit the whole or any part of the manual and any property of the product without the prior written approval of BIXOLON Co., Ltd. The information contained herein is designed only for use with this BIXOLON product. BIXOLON is not responsible for any direct or indirect damages, arising from or related to use of this information.

- The BIXOLON logo is the registered trademark of BIXOLON Co., Ltd.
- All other brand or product names are trademarks of their respective companies or organizations.

BIXOLON Co., Ltd. maintains ongoing efforts to enhance and upgrade the functions and quality of all our products.

In the following, product specifications and/or user manual content may be changed without prior notice.

Caution

Some semiconductor devices are easily damaged by static electricity. You should turn the printer "OFF", before you connect or remove the cables on the rear side, in order to guard the printer against the static electricity. If the printer is damaged by the static electricity, you should turn the printer "OFF".

Compliance information

This device complies with Part 15 of the FCC Rules. Operation is subject to the following two conditions: (1) This device may not cause harmful interference, and (2) This device must accept any interference received, including interference that may cause undesired operation.

This equipment has been tested and found to comply with the limits for a Class A digital device pursuant to Part 15 of the FCC Rules. These limits are designed to provide reasonable protection against harmful interference when the equipment is operated in a commercial environment. This equipment generates uses, and can radiate radio frequency energy and, if not installed and used in accordance with the instruction manual, may cause harmful interference to radio communications. Operation of this equipment in a residential area is likely to cause harmful interference in which case the user will be required to correct the interference at his own expense.

Caution: Exposure to Radio Frequency Radiation.

To comply with FCC RF exposure compliance requirements, a separation distance of at least 20 cm must be maintained between the antenna of this device and all persons.

Caution: Any Changes or modifications not expressly approved by the manufacturer could void the user's authority to operate the equipment.

Class A Digital Device : Wired Device

This Apparatus complies with class "A" limits for radio interference as specified in the Canadian department of communications radio interference regulations.

This Class A digital apparatus complies with Canadian ICES-003.

Appareil numérique de classe A: appareil filaire

Get appareil est conforme aux normes class "A" d'interference radio tel que specifier par ministre canadien des communications dans les reglements d'interference radio.

Cet appareil numérique de la classe A est conform à la norme NMB-003 du Canada.

Waste Electrical and Electric Equipment (WEEE)



This marking shown on the product or its literature, indicates that it should not be disposed with other household wastes at the end of its working life. To prevent possible harm to the environment or human health from uncontrolled waste disposal, please separate this from other types of wastes and recycle it responsibly to promote the sustainable reuse of material resources. Household users should contact either the retailer where they purchased this product, or their local government office, for details of where and how they can take this item for environmentally safe recycling. Business users should contact their supplier and check the terms and conditions of the purchase contract. This product should not be mixed with other commercial wastes for disposal.

Manual Information

This user's guide contains basic information for product usage as well as for emergency measures that may be required.

※ The following separate manuals provide more detailed content on various technological issues and areas.

1. Windows Driver Manual

This manual provides information on the installation instructions and main functions of the windows driver.

2. Unified Label Utility-II Manual

This manual provides information on the usage of software for function selection of this product, operating condition modification, etc.

3. Programming (SLCS) Manual

This manual provides information on label printer commands.

4. True Font Downloader Manual

This manual provides information on the usage of the font downloader that can download true type fonts and facilitate their usage as device fonts.

5. Network Connection Manual

This manual provides information on the configuration and usage of ethernet interface.

6. Label design program Manual

This manual provides information on the usage of the Windows PC program that can make labels by adding text, graphics, or barcodes at desired positions.

Safety Precautions

In using the present appliance, please keep the following safety regulations in order to prevent any hazard or material damage.



WARNING

Warnings must be heeded carefully in order to prevent serious physical harm.

Do not plug several products in one multi-outlet.

- This can provoke over-heating and a fire.
- If the plug is wet or dirty, dry or wipe it before usage.
- If the plug does not fit perfectly with the outlet, do not plug in.
- Be sure to use only standardized multi-outlets.

PROHIBIT

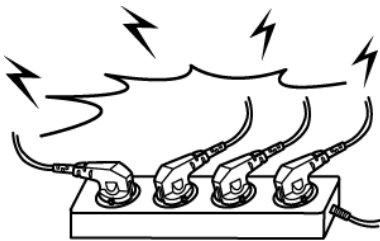

You must use only the supplied adapter.

- It is dangerous to use other adapters.

PROHIBIT



Do not pull the cable to unplug.

- This can damage the cable, which is the origin of a fire or a breakdown of the printer.

PROHIBIT

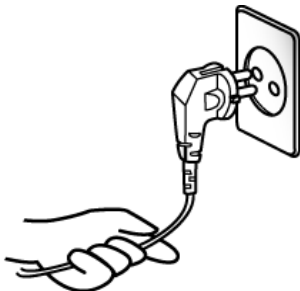

Keep the plastic bag out of children's reach.

- If not, a child may put the bag on his head.

PROHIBIT



Do not plug in or unplug with your hands wet.

- You can be electrocuted.

PROHIBIT

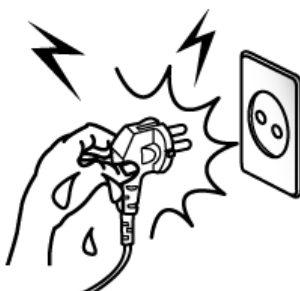

Do not bend the cable by force or leave it under any heavy object.

- A damaged cable can cause a fire.

PROHIBIT

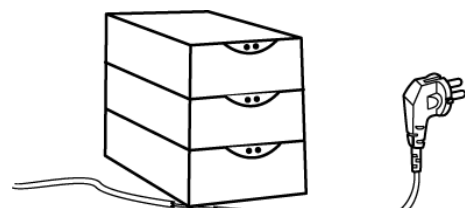



CAUTION

Cautions must be heeded in order to prevent minor injuries, equipment damage, or data loss.

If you observe a strange smoke, odor or noise from the printer, unplug it before taking following measures.

- Switch off the printer and unplug the set from the mains.
- After the disappearance of the smoke, call your dealer to repair it.

TO UNPLUG



Keep the desiccant out of children's reach.

- If not, they may eat it.

PROHIBIT



Install the printer on the stable surface.

- If the printer falls down, it can be broken and you can hurt yourself.

PROHIBIT

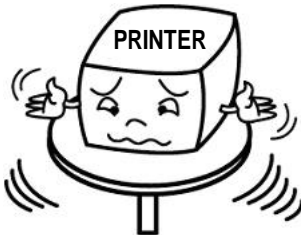

Use only approved accessories and do not try to disassemble, repair or remodel it for yourself.

- Call your dealer when you need these services.
- Do not touch the blade of auto cutter.

DISASSEMBLING PROHIBITED



Do not let water or other foreign objects in the printer.

- If this happened, switch off and unplug the printer before calling your dealer.

PROHIBIT



Do not use the printer when it is out of order. This can cause a fire or an electrocution.

- Switch off and unplug the printer before calling your dealer.

TO UNPLUG



1. Content Confirmation

The following items should all be contained in the printer package.
Contact the dealer from which the purchase was made if any item is damaged and/or missing.

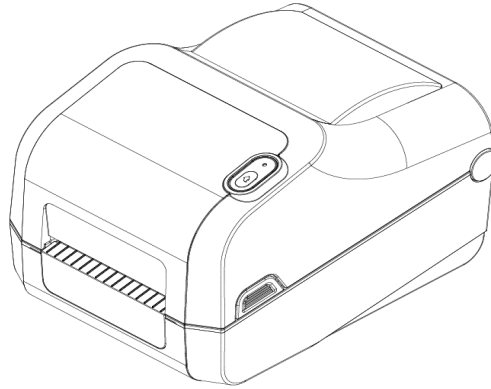

XD3-40t

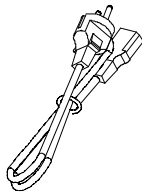

Power Cord

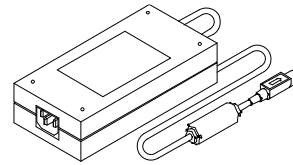

AC/DC Adapter

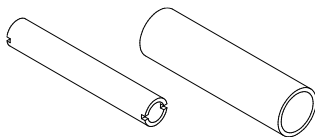

Core(0.5 inch, 1 inch)

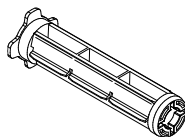

Holder Ribbon (2ea)



Quick Manual



USB Cable

※ **Optional**



Serial(RS-232C) Cable

2. Product Part Names

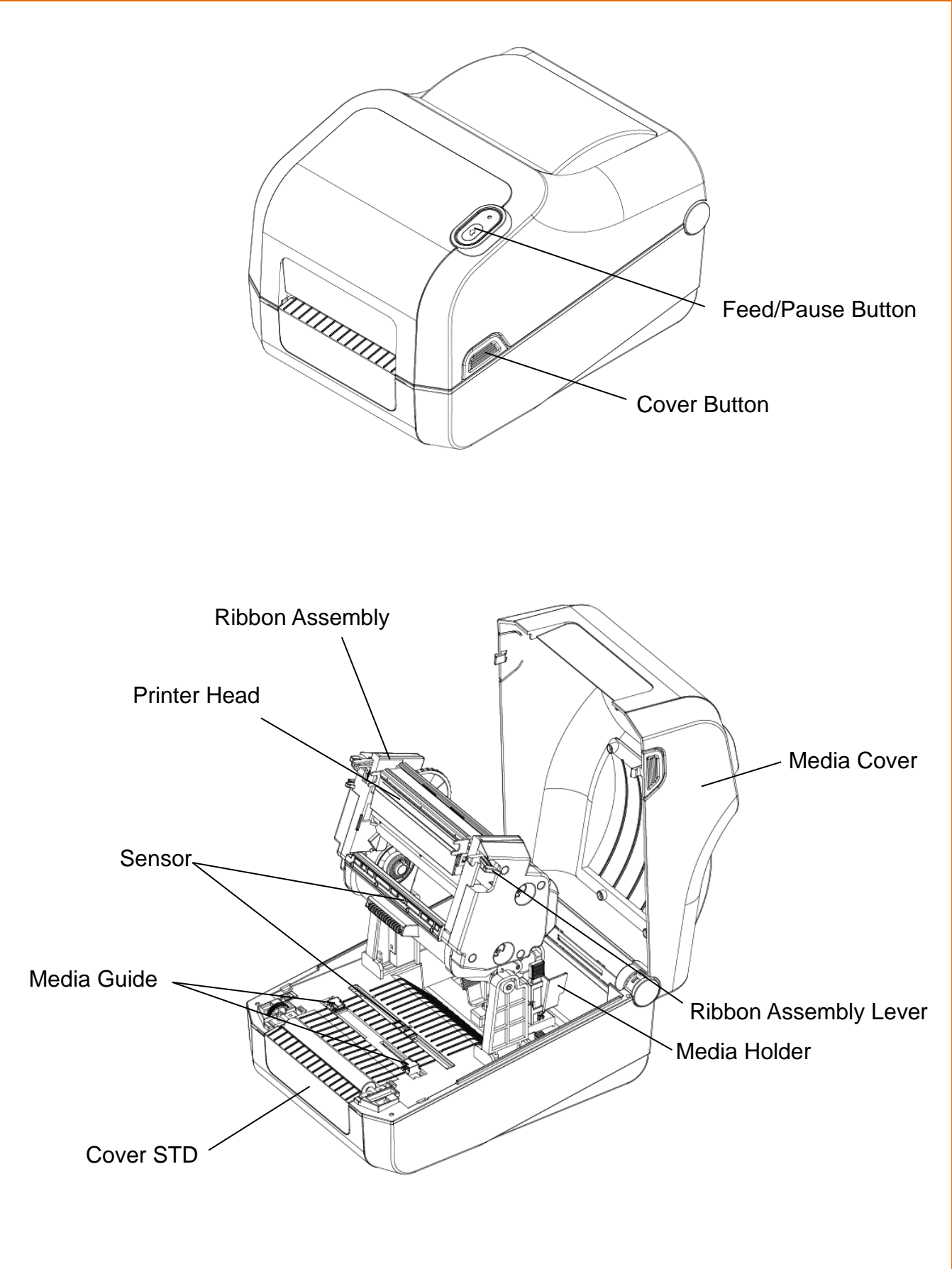

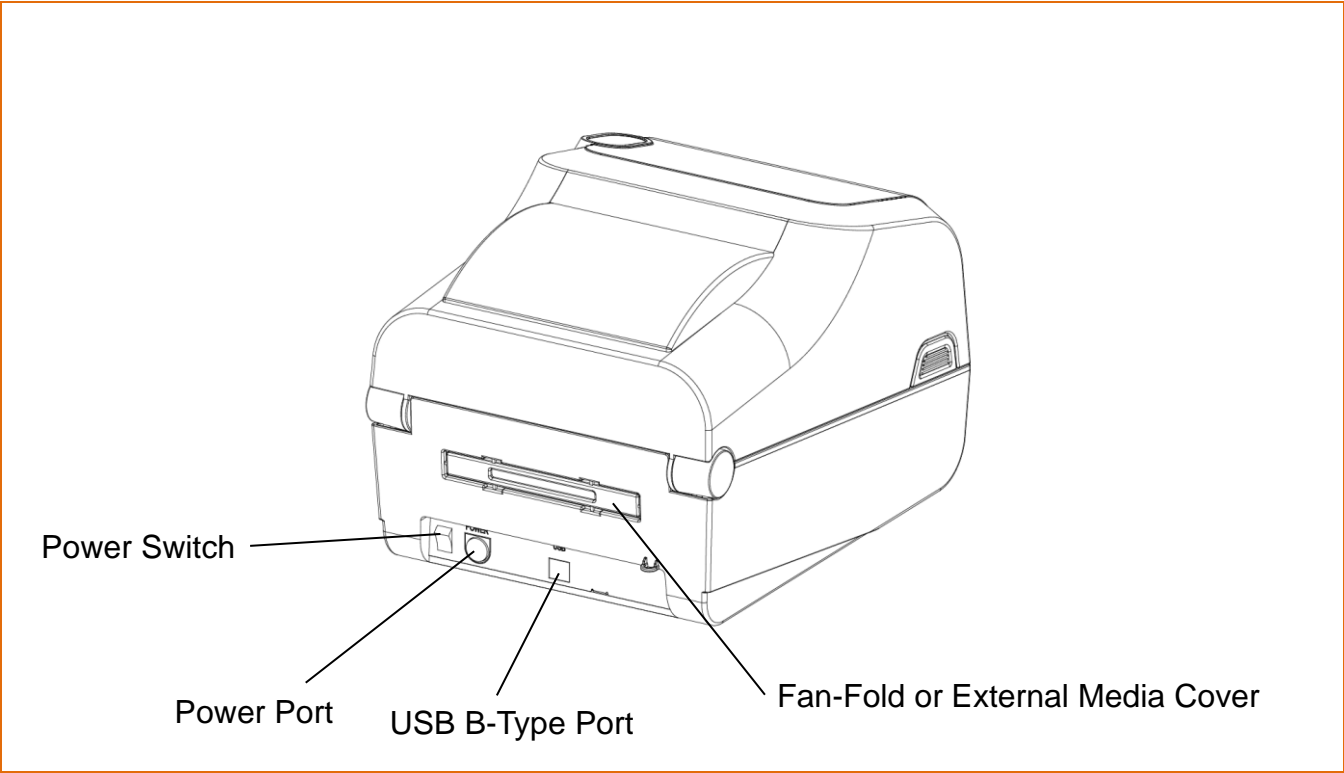

3. Installation & Usage

3-1 Printer Installation Placings

- Install the printer in a location that meets the following conditions.
 - Allow sufficient space around the printer for proper ventilation.
 - Install the printer on a flat and level surface.
 - Avoid humid environment.

3-2 Power Connection

- Connect power to the printer as shown below.

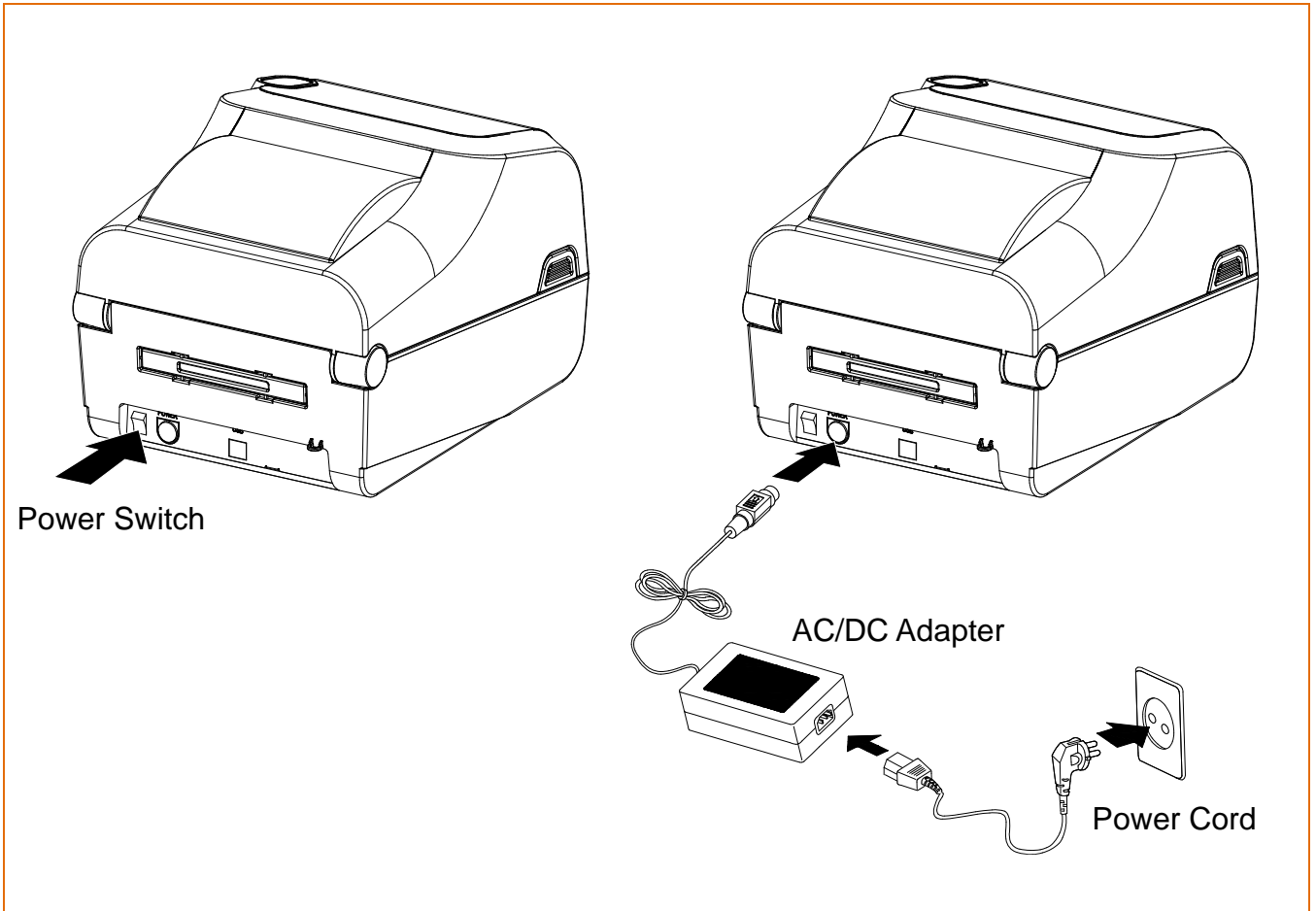

- 1) Turn off the printer power switch.
- 2) Check to see that the AC/DC adapter voltage matches that of the power source.
- 3) Connect the AC/DC adapter to the printer power port.
- 4) Connect the power cord to the AC/DC adapter.
- 5) Connect the power cord to a power source/outlet.
- 6) Turn on the printer power switch.

 **Caution**

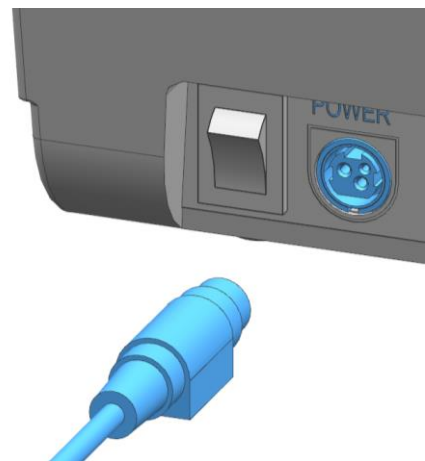

- Only use a power supply provided by BIXOLON.
BIXOLON shall bear no responsibility for damage caused by using a third-party power supply.
- Check the power supply's label to check its electronic specs.
- For the safety of people and equipment, please use the appropriate power cord for your country or region.
- When removing the power supply, make sure you have a firm grasp of power connector and the printer, then pull horizontally.
- Pay attention to the direction of power connector.



 **Warning**

- **Be sure to turn off the printer before connecting the power connector to the printer. This can cause serious electrical damage and bodily injury.**
- **Do not operate the printer and power supply in a humid environment. This can cause serious electrical damage and bodily injury.**
- **Do not connect an input voltage beyond the specifications of the power supply. This may result in product damage and fire.**

3-3 Interface

 Note	<p>Shielded cables must be used to prevent radiation and reception of electrical noise. Use the shortest possible communication cable to minimize the detection of electrical noise in the cable.</p> <ul style="list-style-type: none">- Serial(RS-232C) Cable (1.8m or less recommended)- USB B-Type Cable (1.8m or less recommended)- LAN(Ethernet) Cable (3m or less, CAT-5 or higher UTP Cable)
 Caution	<ul style="list-style-type: none">- Connecting unshielded communication cables is in violation of EMC standards. Use the cable approved by us.- Do not bundle the communication cable with objects that may cause electrical noise and interference. The printer may be damaged.
 Warning	<p>After turning off the power switch of printer, connect or disconnect the communication cable.</p> <p>This can cause serious electrical damage and bodily injury.</p>

3-3-1 Standard Interface(USB only)

Connect the interface cable as shown below.

This printer supports the following communications interface standards.

- USB B-Type Cable

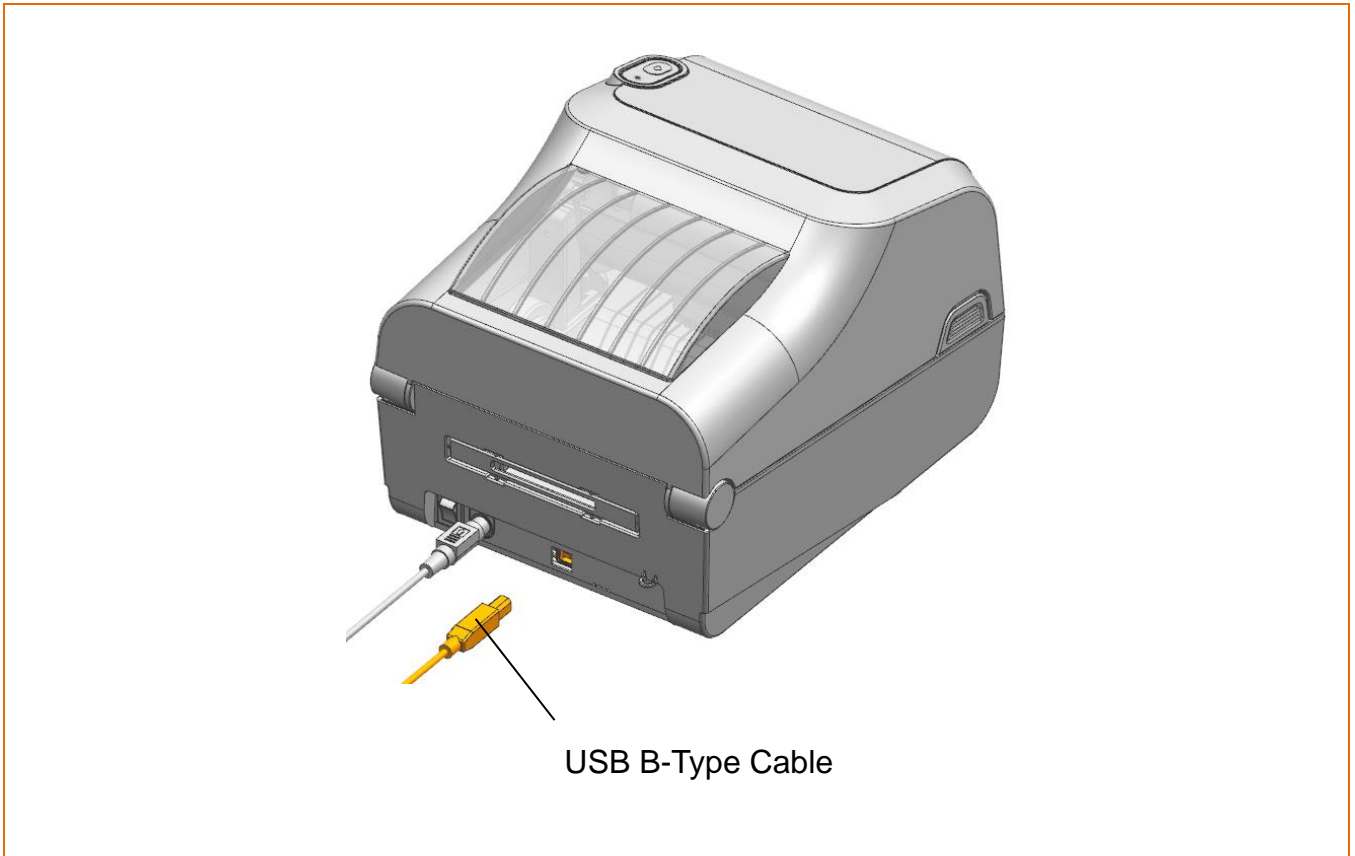

- 1) Turn off the power switch.
- 2) Connect the communication cable to the printer communication port to be used.
 - Connect USB B-Type cable to the USB port.



Be aware that the product's electronic components may be damaged due to discharging of electrostatic energy that accumulates on the surface of the body or other objects.

3-3-2 Option Interface(USB & Serial & Ethernet)

Connect the interface cable as shown below.

This printer supports the following communications interface standards.

- Serial(RS-232C) Cable
- LAN(Ethernet) Cable
- USB B-Type Cable

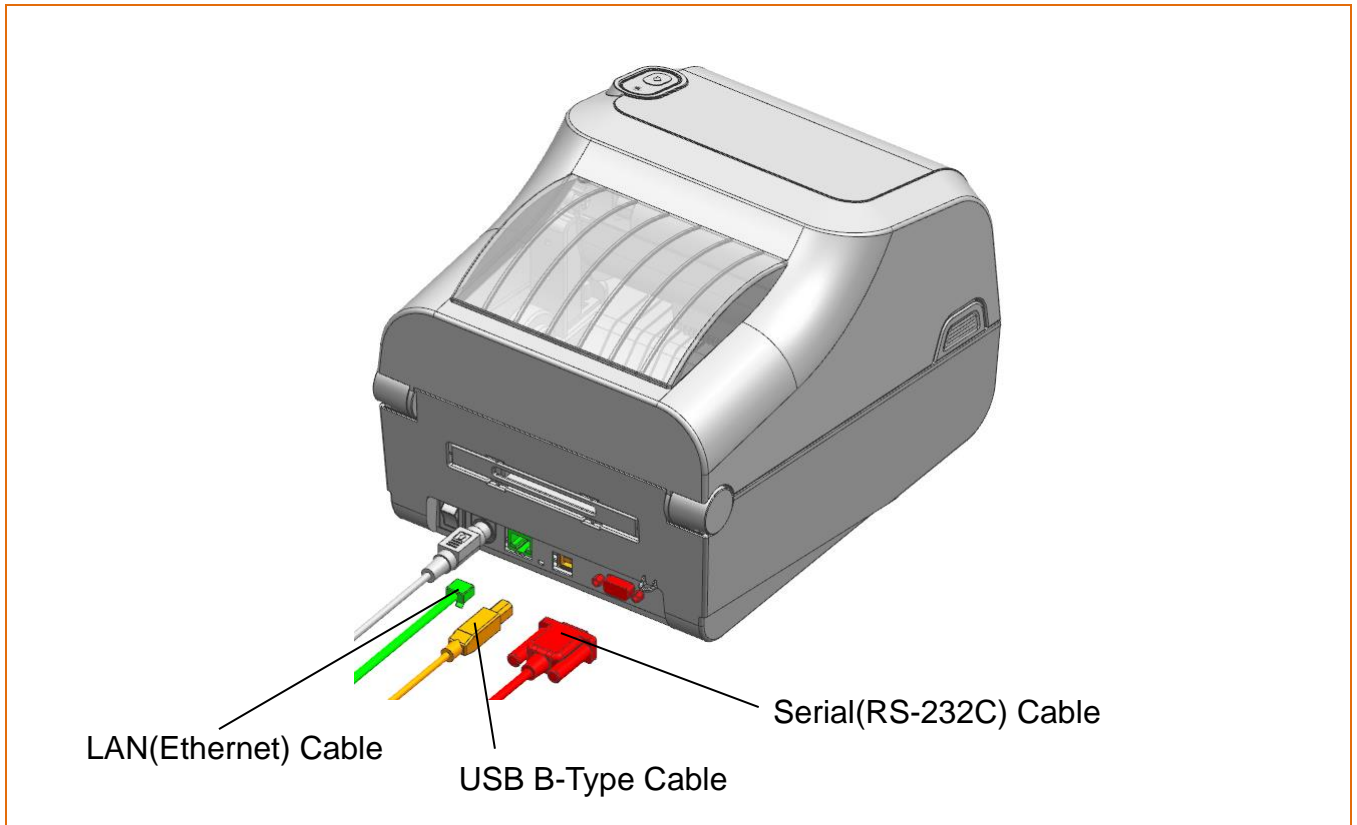

1) Turn off the power switch.

2) Connect the communication cable to the printer communication port to be used.

- Connect the serial(RS-232C) cable to the serial port and tighten the screw on both sides.
- Connect the LAN(ethernet) cable to the Ethernet port.
- Connect USB B-Type cable to the USB port.



Be aware that the product's electronic components may be damaged due to discharging of electrostatic energy that accumulates on the surface of the body or other objects.

3-4 Media Installation

1) Open the media cover as push the cover button on both sides of the media cover.

Media Cover

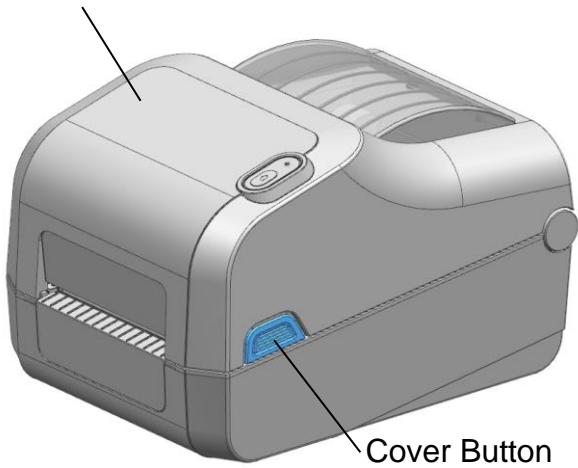

2) Spread the media holder and insert media as shown.

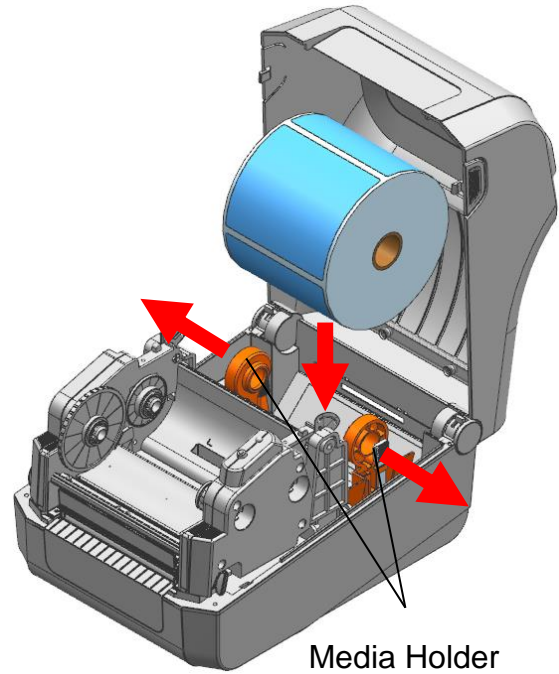

3) Pull the ribbon assembly lever on both sides of the ribbon assembly and open the ribbon assembly.

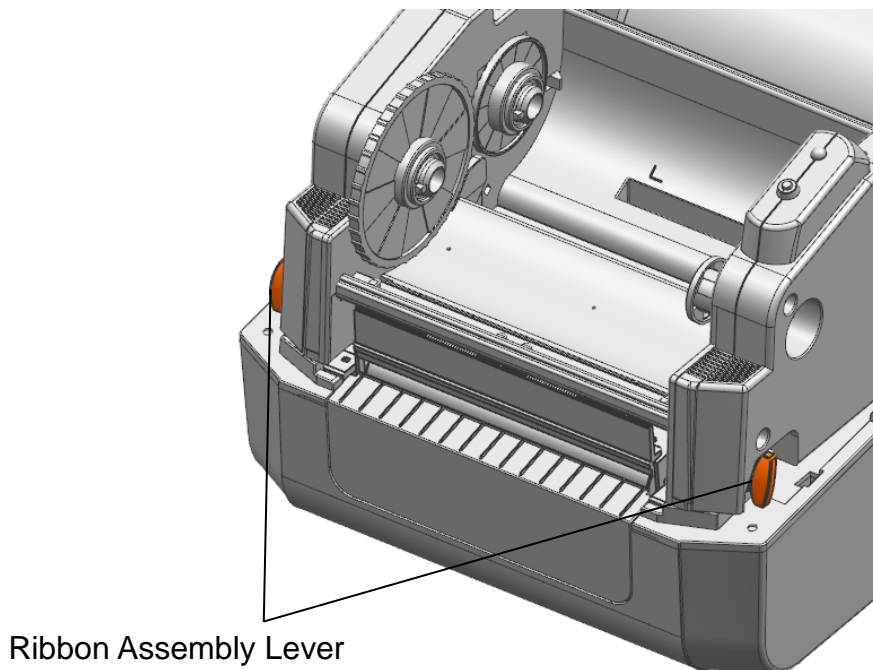

4) Feed the media between the media guide on both side.

* Whether the media is rolled outside or inside, the printing side must faced up.

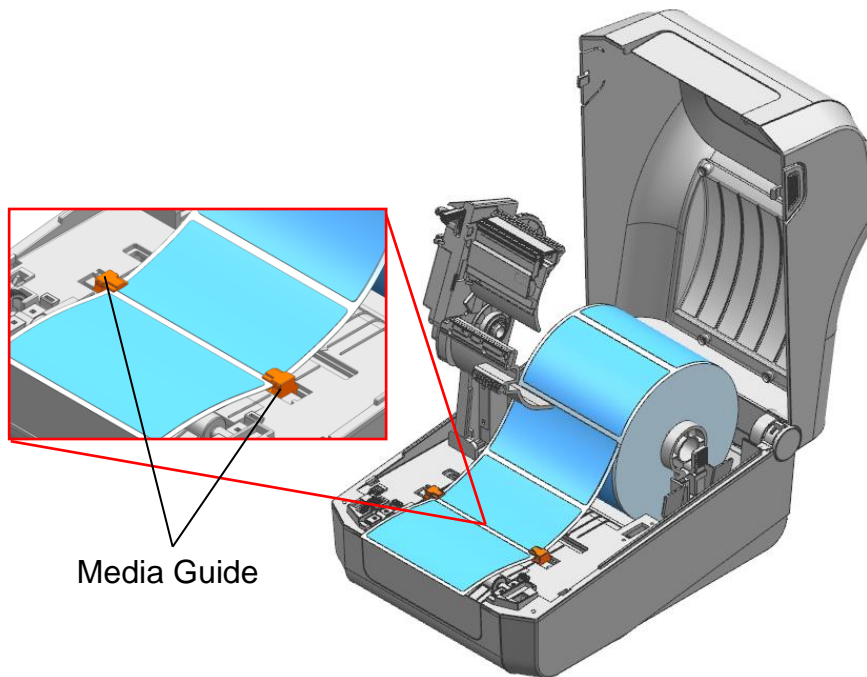

5) If you use black mark or notch media roll, please lift up the media and match the sensor position adjust the black mark or notch hole.

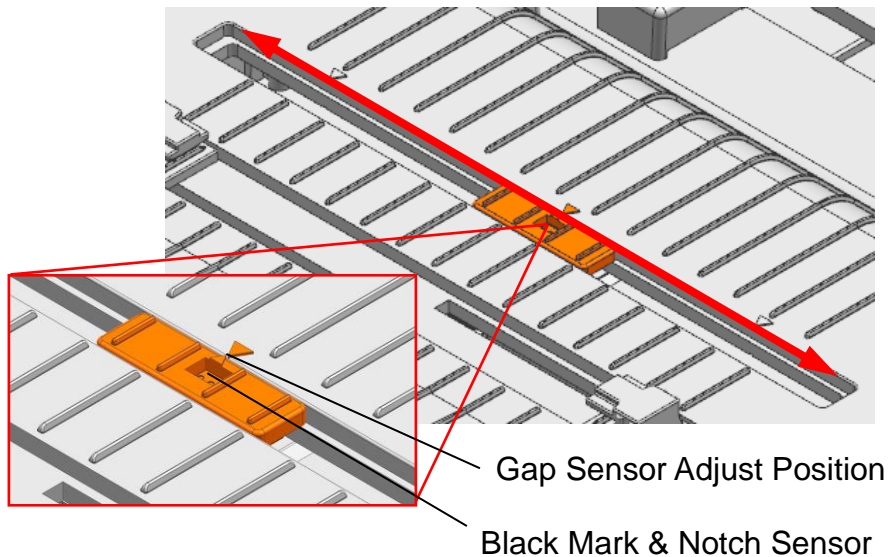

⚠ Caution

- When opening or closing the cover, be careful not to pinch your fingers.
- Do not open the print head levers while the printer is printing. The printer may be damaged.
- Change the media when the printer is not receiving data, or data may be lost.

⚠ Warning

While the printer is operating, the print head gets very hot, so turn off the power and let it cool down completely. The hot print head can cause serious burns.

3-5 Ribbon Installation

3-5-1 Type of Ribbon

1) Type by Film Coating Location

- Take note before ribbon purchase that only ribbons facing outward can be used.

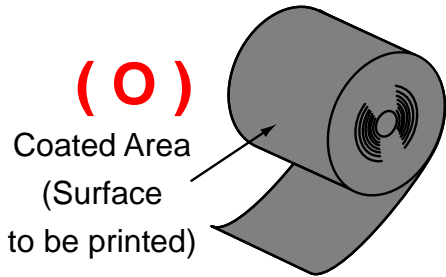

Outside Ribbon

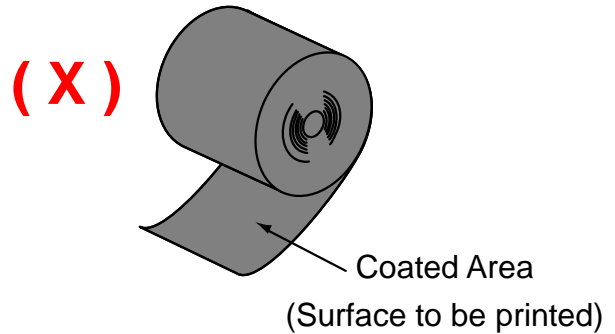

Inside Ribbon



Note

Follow the procedure described below to determine the coating surface of the ribbon.

- Ribbon test using adhesive material
 - Perform contact test in order to determine which side is coated if there are useable labels.
- Complete the following steps to carry out the contact test
 - Remove the liner from the label
 - Put a piece of adhesive surface of the label on the outer/inner surface of the ribbon, and apply pressure.
 - Remove the label from the ribbon
 - Check whether adhesive surface of the label is stained by black ink ribbon.

2) Type by Roll Core

- This printer can be used to one-inch or half-inch core ribbon.
- For a 1-inch core, a roll core must be used.
- The holder ribbon and roll core of the fully used ribbon must be reused.
Do not discard.

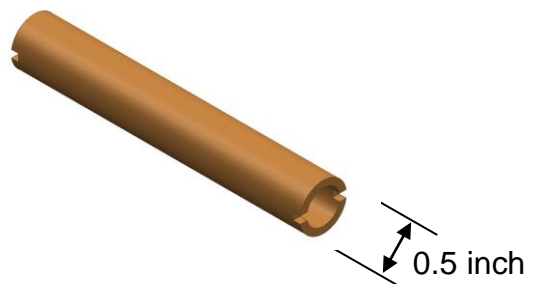
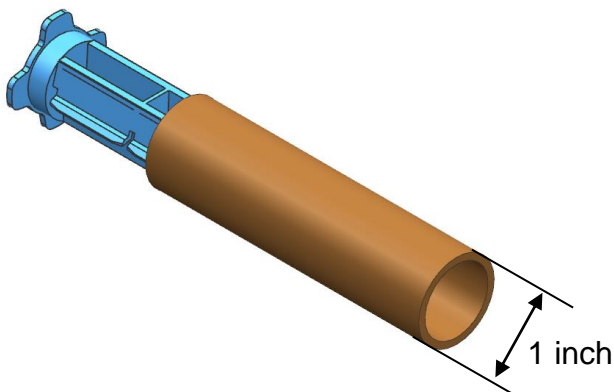

3-5-2 Inserting a One-Inch Core Ribbon

1) Insert the Holder ribbon into the core and ribbon. (keep note of ribbon printing direction)

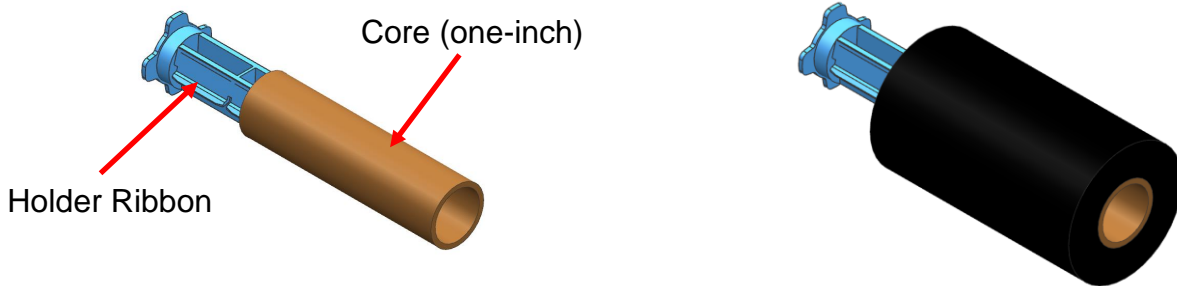

2) Open the ribbon assembly and insert the ribbon and core by pushing from left to right.

3) Apply tape to the core of the ribbon.

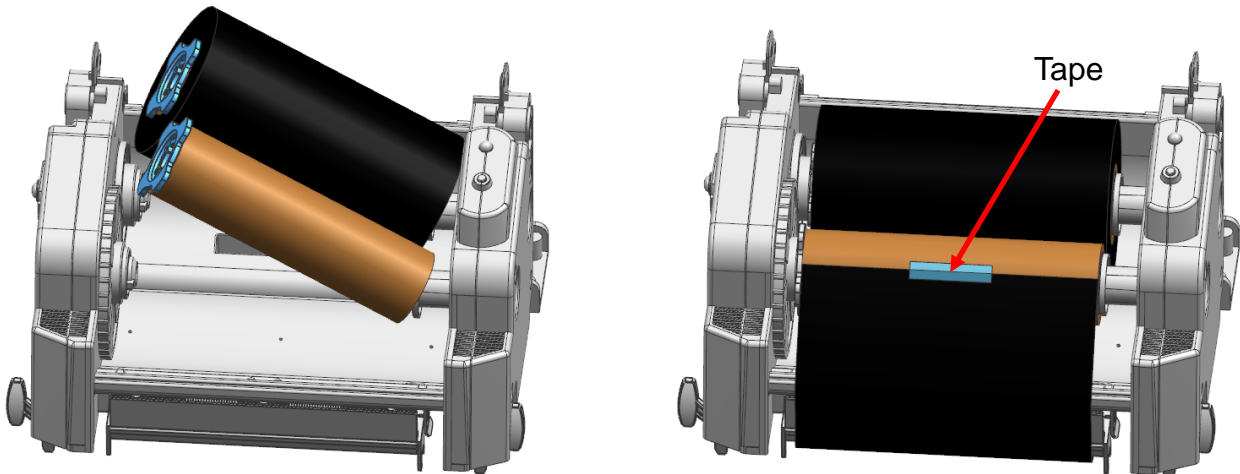

4) Press the Close area to shut the ribbon assembly.

 **Note**

Please refer to the figure below for the ribbon installation path.

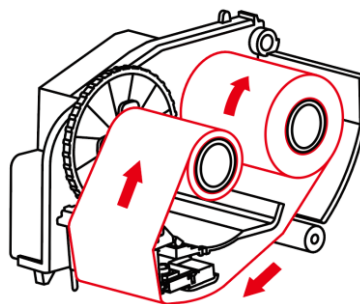

3-5-3 Inserting a Half-Inch Core Ribbon

1) Open the ribbon assembly and insert the ribbon and core by pushing from left to right. (keep attention of ribbon printing direction)

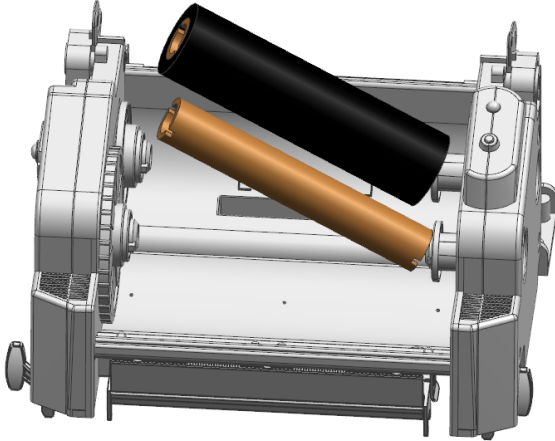

2) Apply tape to the core of the ribbon.

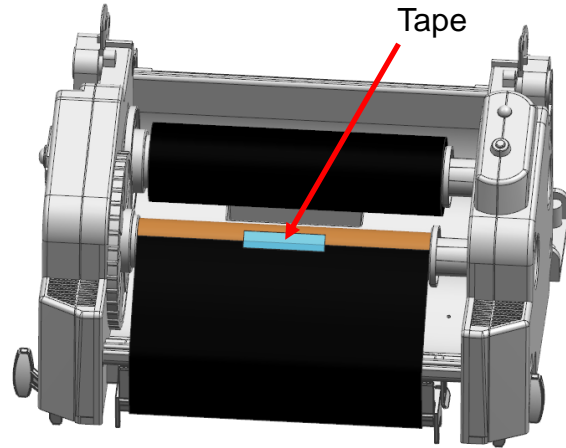

Please refer to the figure below for the ribbon installation path.

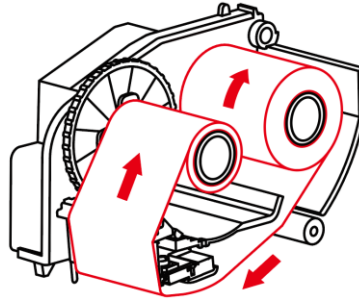

 **Note**

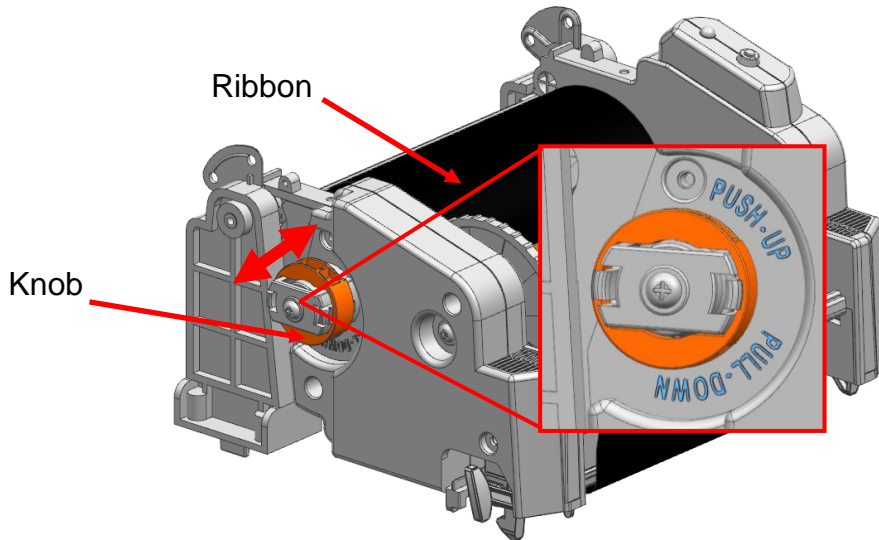

3-5-4 Knob Adjust Method According to Ribbon Length

Use printer after adjusting knob correctly, according to ribbon length and width.
 PUSH-UP state of knob to which being inward is the factory default specification and you can push or pull the knob.
 Please note that push or pull operation affects print quality and operation.

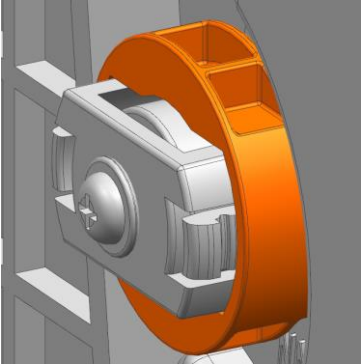
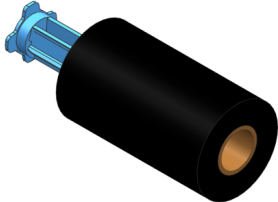
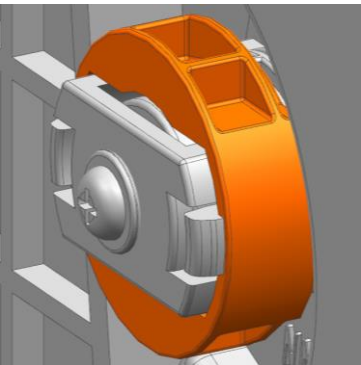
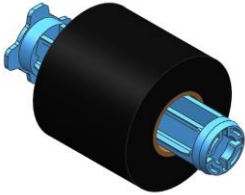

Knob Status	Ribbon Type	
 <p data-bbox="252 1480 391 1514">PUSH-UP</p>	 <p data-bbox="759 1346 1246 1384">≈ 300m (One-inch core) Ribbon</p>	
 <p data-bbox="225 1942 418 1975">PULL-DOWN</p>	 <p data-bbox="580 1899 951 1980">≈ Under 2 Inches Width (One-inch Core) Ribbon</p>	 <p data-bbox="1059 1899 1422 1980">≈ 74m (Half-inch Core) Ribbon</p>

3-5-5 Narrow Ribbon Installation

When using ribbons of widths of 110mm or lower, install in a centered position on the holder ribbon.

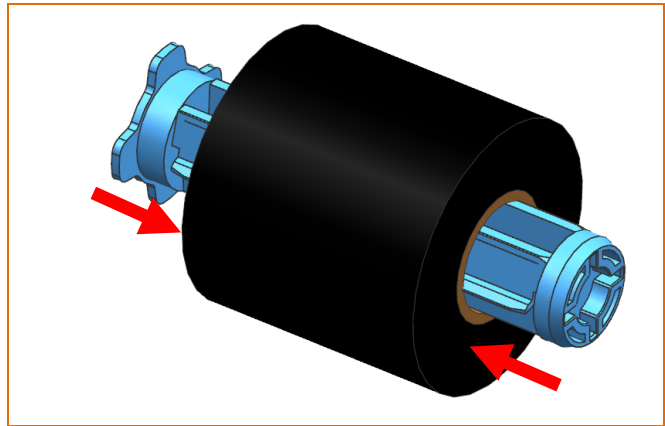

3-5-6 Ribbon Removal

- 1) Cut the ribbon.
- 2) Open the ribbon assembly and remove the ribbon and core by pushing from left to right.
- 3) Detach the ribbon holder from the ribbon and core.

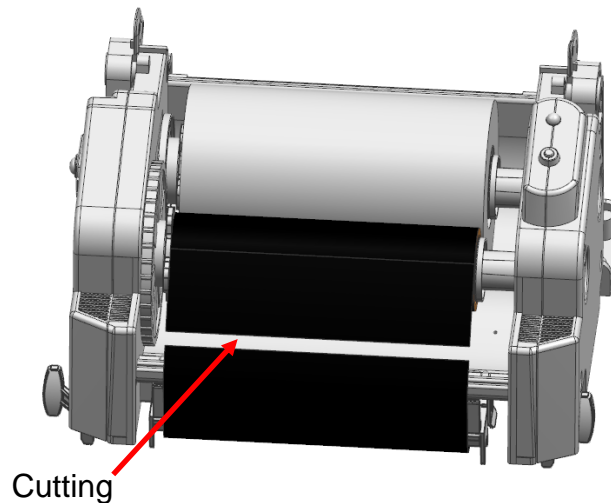

3-5-7 Ribbon Sensor Activation

Check the settings related to ribbon detection sensor if printing does not stop when the printer is out of ribbon or ribbon is broken.

- * Ribbon detection sensor can be enabled by command control. And default setting can be changed by Unified Label Utility.



Caution

- When replacing a ribbon, keep affixed the core of the fully used ribbon to the ribbon coiling portion on the other side and do not discard as its use is required.
- As the ribbon holder is required for continuous use, make sure not to misplace it.

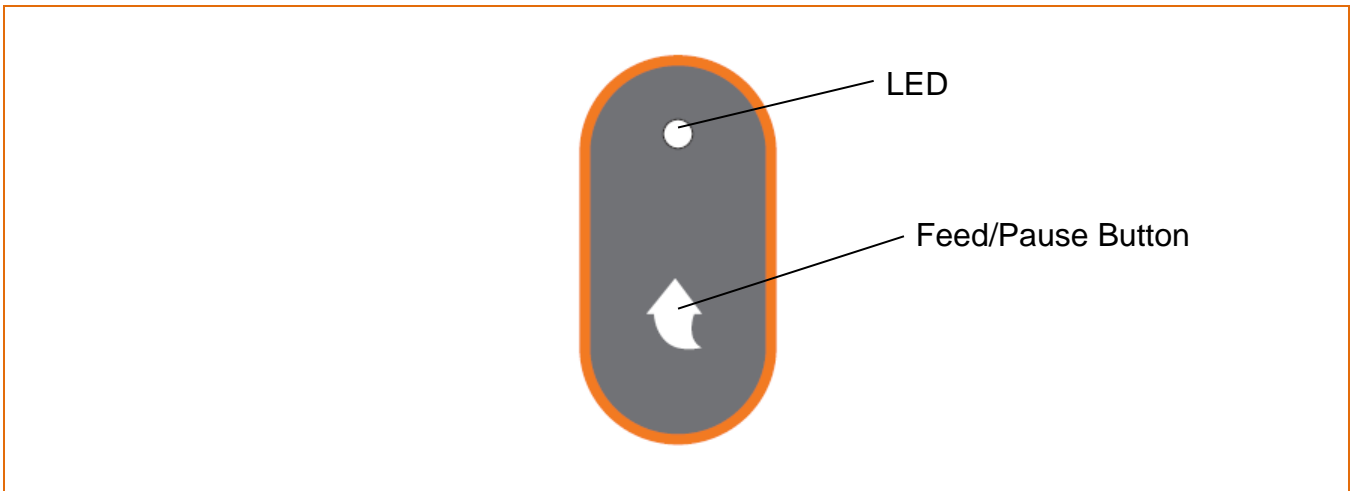
3-6 Control Panel

Feed/pause button(



LED: The current printer status can be viewed. (Refer to below)

The current printer status can be viewed via the printer's LED display.

1) Green LED on

- The printer waits for the data from host (PC) in normal mode.

2) Green LED blinking

- The printer has stopped by pressing feed/pause button().
- It restarts printing when pressed feed/pause button() again.

3) Orange LED on

- It means media gap/black mark sensing error.
- It becomes on when the printer fails to detect the media or media jam occurred.
- When it fails to detect the media correctly, use auto calibration function.

4) Orange LED blinking

- No media or ribbon. Make sure the media and ribbon is loaded correctly.

5) Red LED on

- The ribbon assembly is open.

6) Red LED blinking

- TPH (Thermal Printing Head) overheated.

3-7 Feed/Pause Button Operations

• Feed/pause button() can be used for various purposes as follows.

1) Media Feed

In print standby state, pressed for shorter than 3 seconds, the printer feed one media.

2) Stand-alone Configuration Mode

In print standby state, pressed for longer than 3 seconds, the printer enters into stand-alone configuration mode. Please refer to 5-1 for details.

3) Pause and Resume Printing

If pressed while printing, printing toggled between pause and resume.

4. Self-test

The self-test checks whether the printer has any problems.

(Remove the printed label from peeler before using the self-test if using the printer's label peeler option.)

The self-test checks the following;

- 1) Make sure that the media roll has been installed properly.
- 2) Turn on the power while holding down the feed/pause button(). The self-test begins.
(It takes about 10 seconds before starting self-test)
- 3) The self-test prints the current printer configuration information.
- 4) After the self-test results are printed out, a printer enters into print standby state.





If the printer does not function properly, contact an authorized dealer.

5. Detailed features

5-1 Stand-alone Configuration Mode

- Various modes can be executed by using button and LED status.

5-1-1 Start Stand-alone Configuration Mode and execute each function

- 1) Make sure that a printer is in print standby state.
- 2) Press the feed/pause button() for about 3 seconds, then the LED changes to orange color.
- 3) Release the feed/pause button() , then the printer starts the stand-alone configuration mode and 6 numbers of LED status changes sequentially.
- 4) When the feed/pause button() is pressed at specific LED status, the corresponding operation will be executed.

5-1-2 Function List of Stand-alone Configuration Mode

Sequence Number	LED		Printer Operation
	Color	Status	
1	Green	Blink 4 times	Self-Test
2	Orange	Blink 4 times	Factory Reset and Gap Calibration
3	Red	Blink 4 times	Factory Reset and Black Mark Calibration
4	Green	Keep On 3 seconds	Reserved
5	Orange	Keep On 3 seconds	Data Dump Mode
6	Red	Keep On 3 seconds	Demo Mode

* This information can be printed out by printer self-test.



Caution

Contact an authorized dealer if the printer does not enter stand-alone configuration mode.

5-2 Media Length Measurement

- The printer needs to have the exact length of currently installed media to make a proper print.



For this, the printer automatically starts media length measurement mode in the following conditions.

- 1) When the printer has no measure length, for example first feeding after installation.
- 2) When the detected media length differs from the measured value.

In this mode, the printer feeds 2 or 3 media to measure the exact length of media and saves the measured value on printer's non-volatile memory.

5-3 Pause/Resume

- Press feed/pause button() to pause at the middle of media printing.

- 1) Press feed/pause button() once while printing.
- 2) Printer stops after on-going printing and green LED is blinking
- 3) Press feed/pause button() once again. It resumes printing in a queue.



Caution

Contact an authorized dealer if the printer does not execute pause/resume function.

5-4 Gap Sensor Auto Calibration Mode

- Gap sensor auto calibration mode is used when the printer does not detect a gap on the media correctly.

Generally a printer is set to detect most types of gap but sometimes it fails to detect and keep feeding the media without a stop when special media used. In such case, use gap sensor auto calibration mode function for a proper detection.

- 1) Make sure that media roll has been installed properly.
- 2) Use stand-alone configuration mode, sequence number 2 (refer to 5-1)
 - Sequence number 2: Gap media auto calibration mode



Caution

Contact an authorized dealer if the printer does not execute gap sensor auto calibration mode function.

5-5 Black Mark Sensor Auto Calibration Mode

- Black mark sensor auto calibration mode is used when the printer does not detect a black mark on the media correctly.

Generally a printer is set to detect most types of black mark but sometimes it fails to detect and keep feeding the media without a stop when special media used. In such case, use black mark sensor auto calibration mode function for a proper detection.

- 1) Make sure that media roll has been installed properly.
- 2) Use stand-alone configuration mode, sequence number 3 (refer to 5-1)
 - Sequence number 3: Black mark media auto calibration mode



Contact an authorized dealer if the printer does not execute black mark sensor auto calibration mode function.

5-6 Media Sensor Manual Calibration

- Manual calibration of media detection can be used when the printer cannot detect a media gap(or black mark) even after gap(or black mark) auto calibration mode has been executed.

Users can calibrate sensor parameters in detail by using the utility program provided by the manufacturer.

The utility can be obtained from the Internet via the BIXOLON website www.bixelon.com.

Please make sure the printer is connected and execute the utility program.

Please press the calibration setting manager button after setting the interface type.

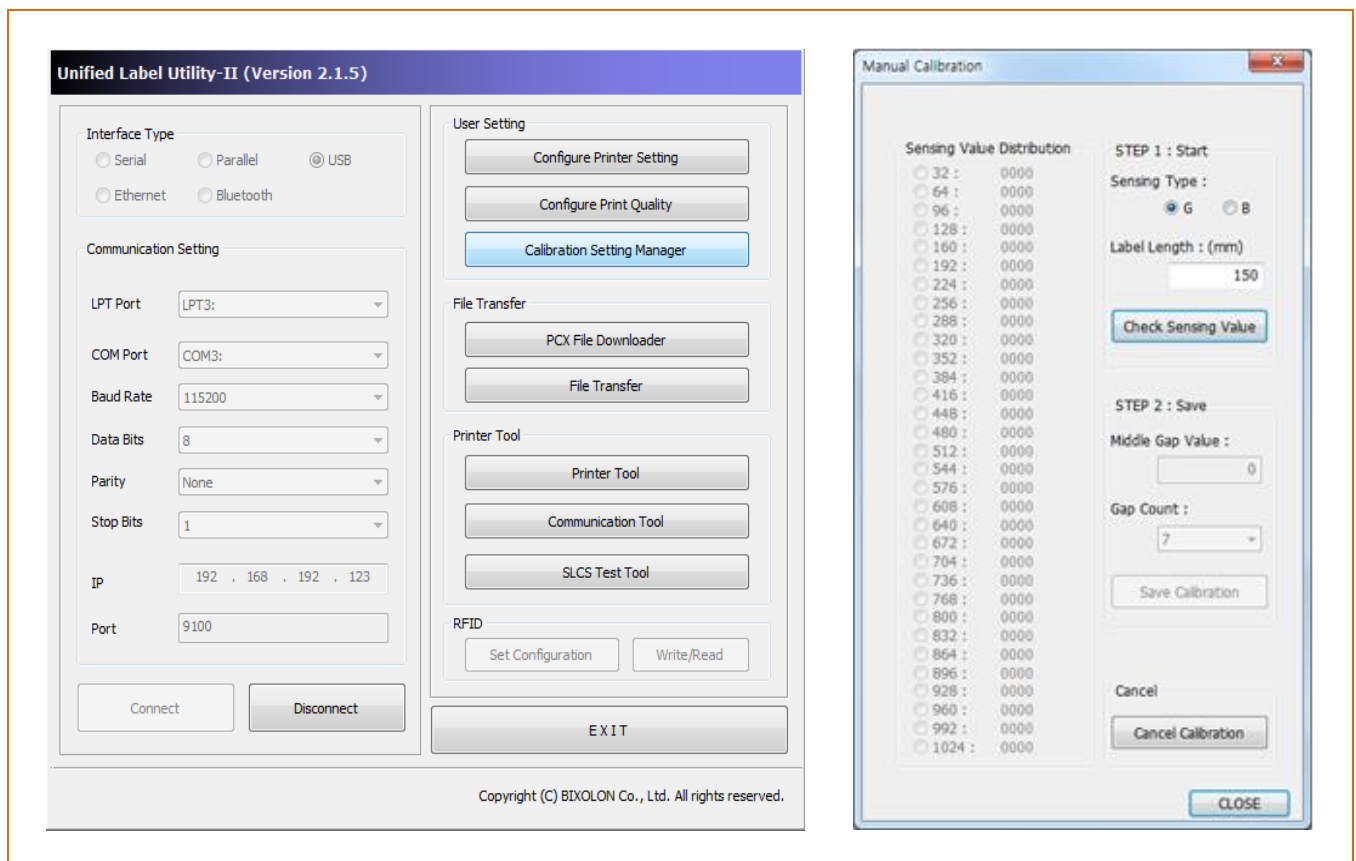

- 1) Select the sensing type and input the label length(mm) and click on “Check Sensing Value” button then printer starts to calibrate.
- 2) After calibration, the scanned values will appear on the screen.
- 3) Optimal sensing values will appear in black bold letters on the left of the utility screen and select one of the values and click on “Save Calibration”
- 4) If chosen value does not work properly, please try the other values among the black bold letters.
- 5) To go back to the initial value, please click on “Cancel Calibration” button.



Caution

Contact an authorized dealer if the printer does not enter media sensor manual calibration mode.

5-7 Data Dump Mode

- This function can be used to diagnose the communication issues when the printer does not work correctly.

In this mode, the received data will be printed in hex format.

Use stand-alone configuration mode, sequence number 5(refer to 5-1) to start data dump mode.

Turn the printer off and on to recover to the print standby mode.



Contact an authorized dealer if the printer does not enter data dump mode.

5-8 Media Installation Method of Peeler(Optional) Model

- Use a peeler to automatically separate the printed media from the liner.
For peeler model, install media in the following ways:

- 1) Open the media cover and ribbon assembly.
- 2) Open the peeler cover.

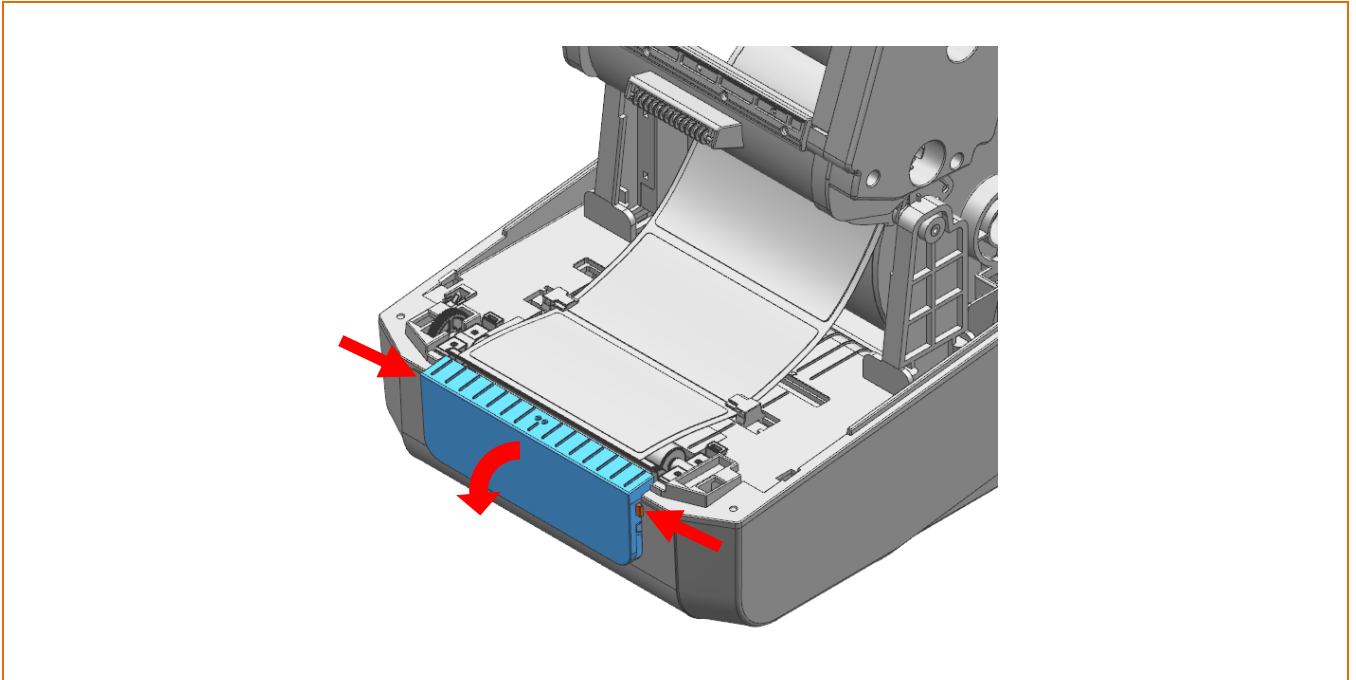

- 3) Set the peeler switch to the 'ON' position and check to see that the LED has turned on.

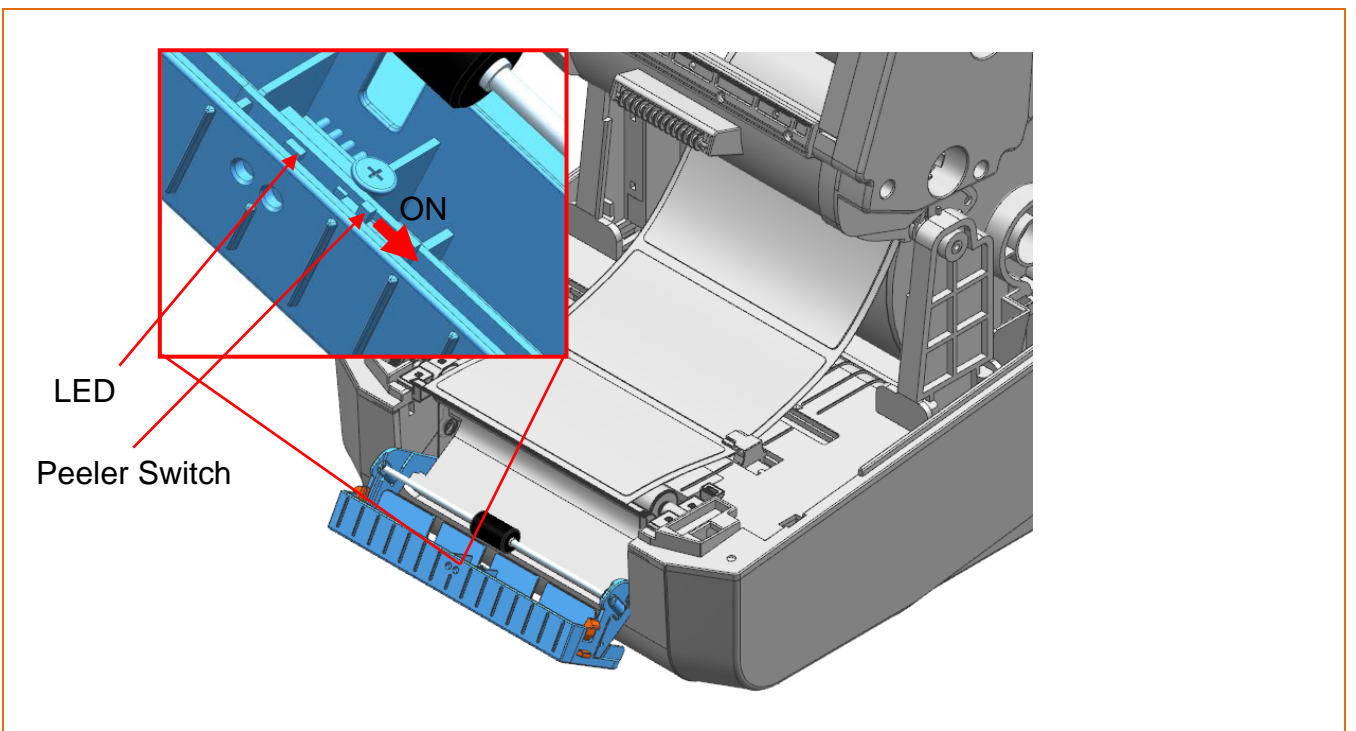

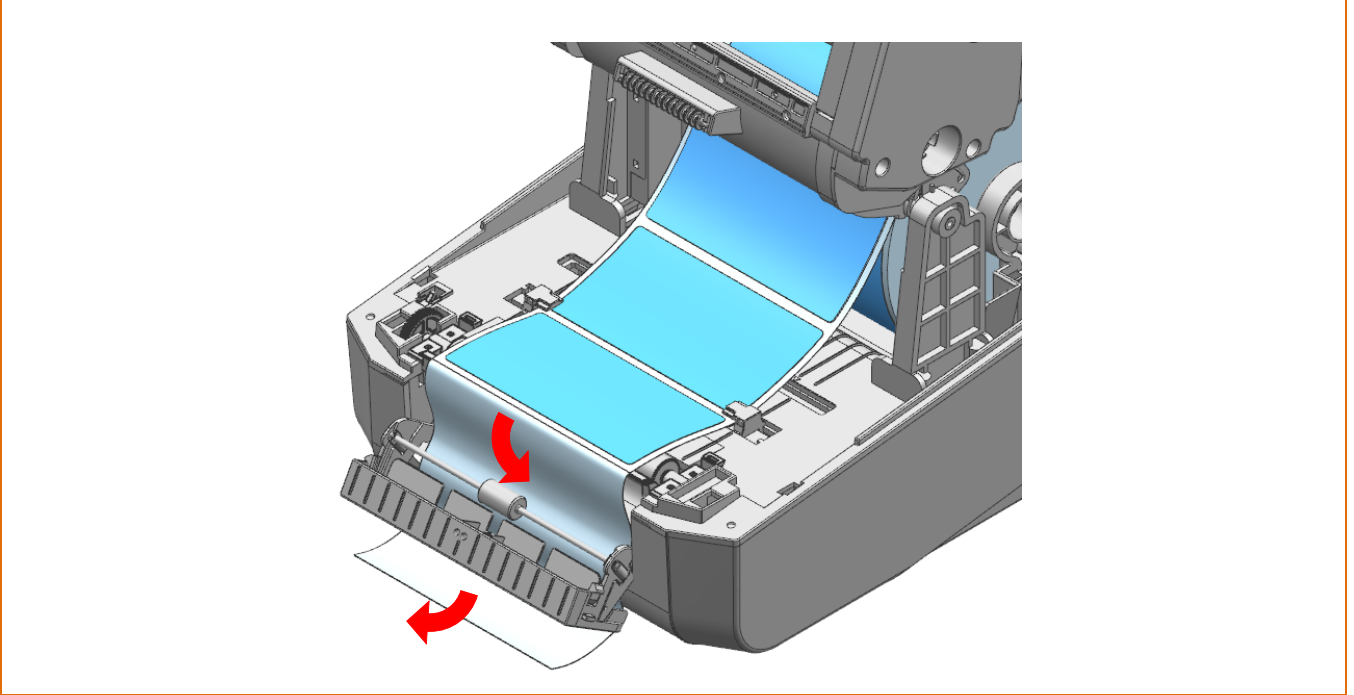

4) Remove a label of the media and insert the liner through the slot.

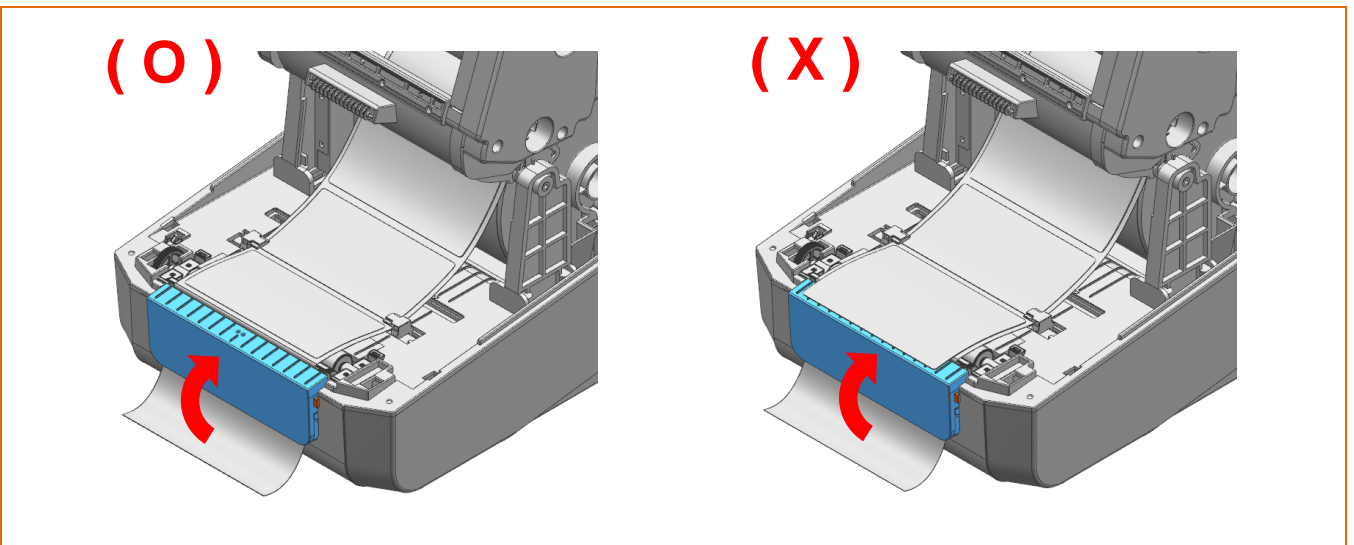

5) Close the peeler cover until a click sound is heard.



6) Close the ribbon assembly and media cover until a click sound is heard.

 Caution	<ul style="list-style-type: none">- When opening or closing the cover, be careful not to pinch your fingers.- The peeler function is only available for gap media.- When the peeler is switched on, the next label will not be printed unless the printed label is removed from the peeler.- When the peeler is switched off, the peeler does not work.
 Warning	<p>While the printer is operating, the print head gets very hot, so turn off the power and let it cool down completely. The hot print head can cause serious burns.</p>

5-9 Using Fan-Fold or External Media

- Supplying media to the printer externally is done as follows.

5-9-1 Printer Preparation

Remove the rear media supply cover on the back side of the printer.

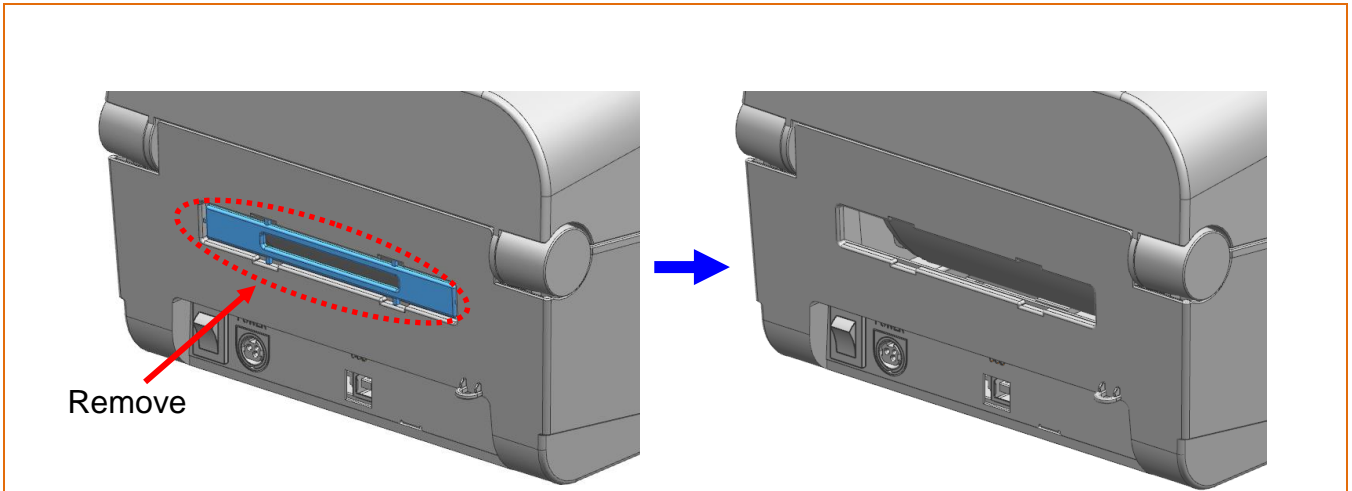

Caution

Take care not to injure the hands and/or any other part of the body when performing this step

5-9-2 When using Fan-Fold Media

Supplying fan-fold media to the printer externally is done as follows.

1) Insert the media at the rear of the printer as shown below.

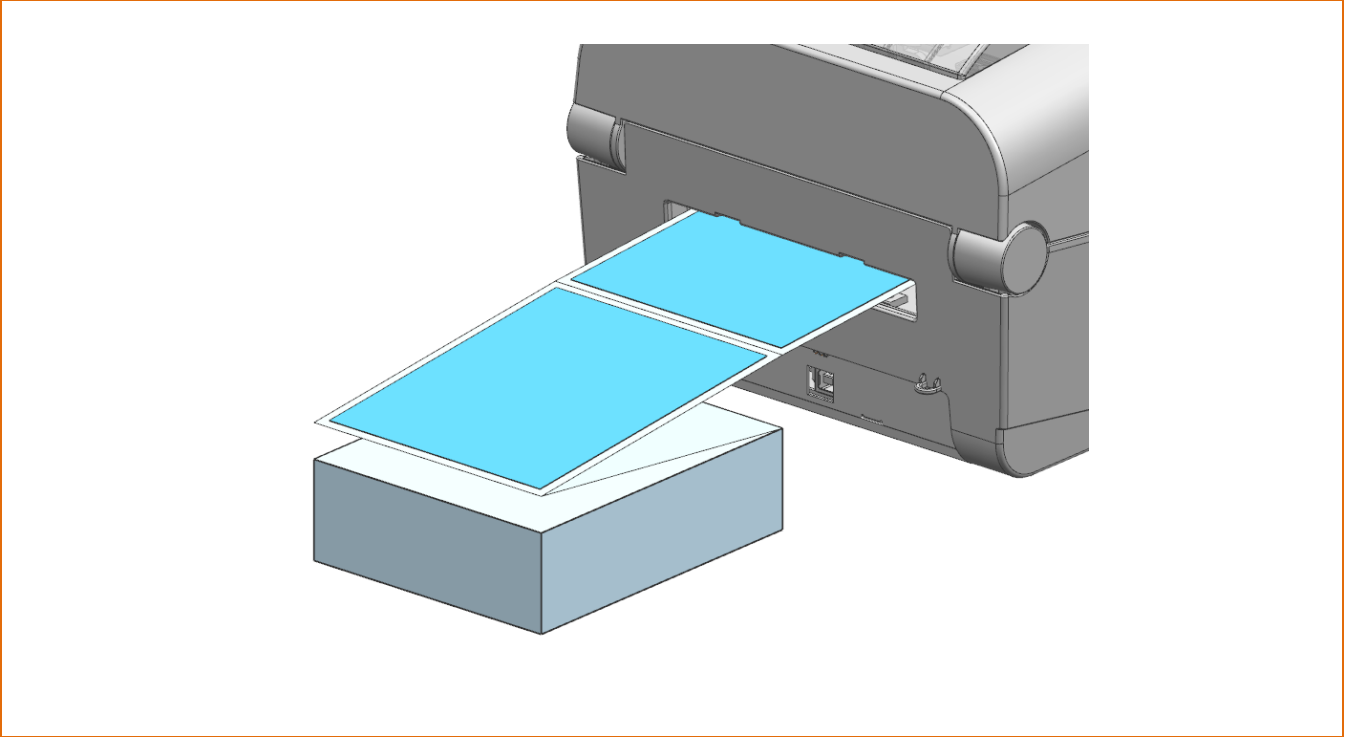

2) Adjust media holders to the media width by using the fix tool.

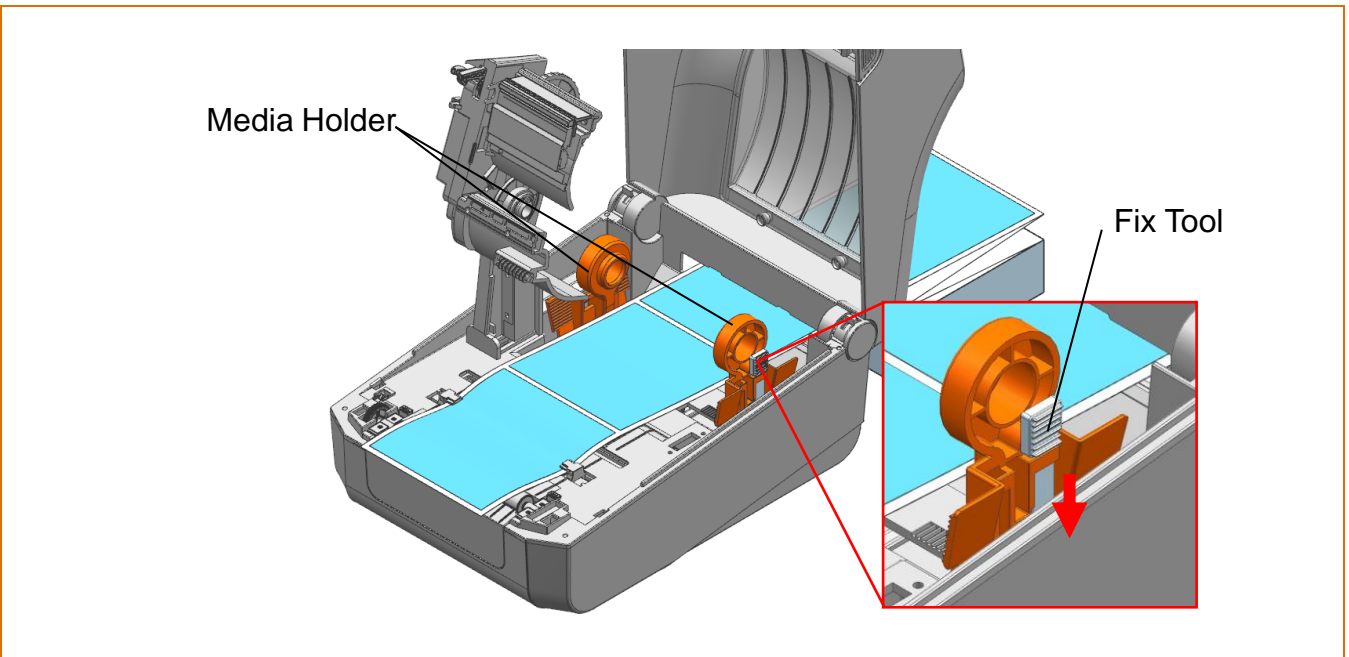

5-9-3 When using Large-Capacity Media Roll(Optional)

Install the external media supplier(LES-400G) as shown below and adjust media holders to the

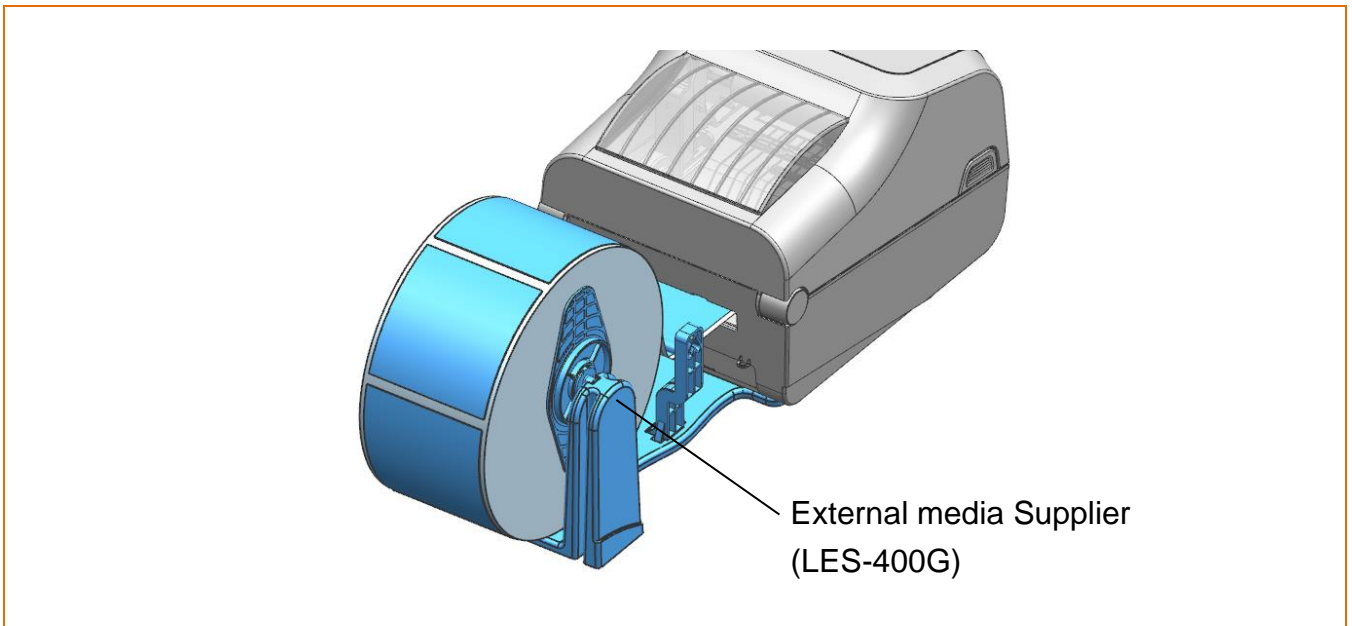

media.

 **Caution**

- Do not open the print cover while the printer is operating, otherwise the printer may be damaged.
- To prevent data loss, replace media only when the printer is not receiving any data.

6. Printer maintenance



Printing quality might be degraded by dust, foreign substance, adhesive substance, or other pollution materials stuck in the printer head or inside the printer.

In this case, clean the print head as follows.

6-1 Cleaning Head

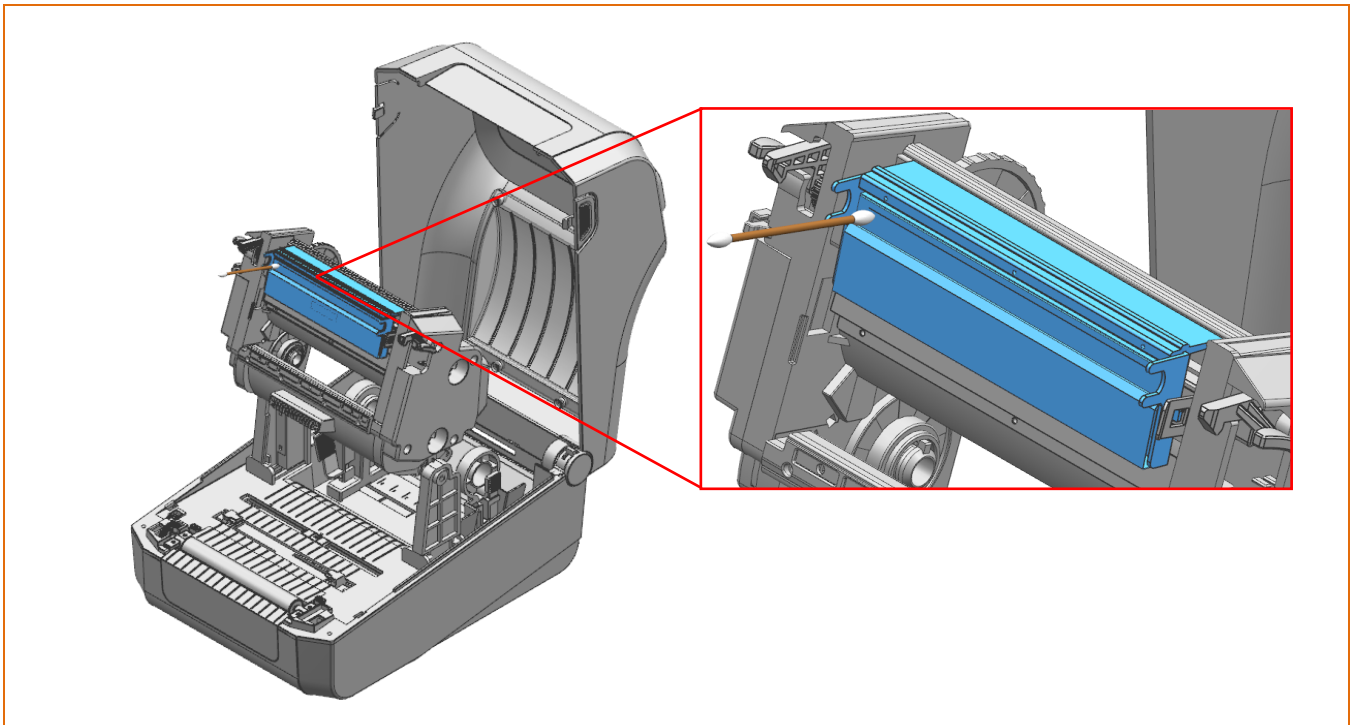
- 1) Open the media cover and ribbon assembly then remove adhesive foreign substances or other pollution materials with the cloth or cotton swab soaked in alcohol for medical.
- 2) After cleaning the head, do not use the printer until the alcohol used for cleaning evaporates completely. (1~2 min)



 Note	Perform the cleaning process each time the media roll is replaced to prevent print quality deterioration.
 Caution	<ul style="list-style-type: none"> - Be sure to clean after turning the printer off. - Be careful not to leave scratches in the print head. The printer may be damaged.
 Warning	<p>Do not touch heated area of print-head when cleaning. This can cause serious damage and bodily injury.</p>

6-2 Cleaning Sensors, Roller or/and Media Path

- 1) Open the media cover and ribbon assembly, then remove the media.
- 2) Clean any dust or foreign substance using dry cloth or cotton swab.
- 3) Soak the cloth or cotton swab in alcohol for medical use and use it to remove adhesive foreign substances or other pollution materials.

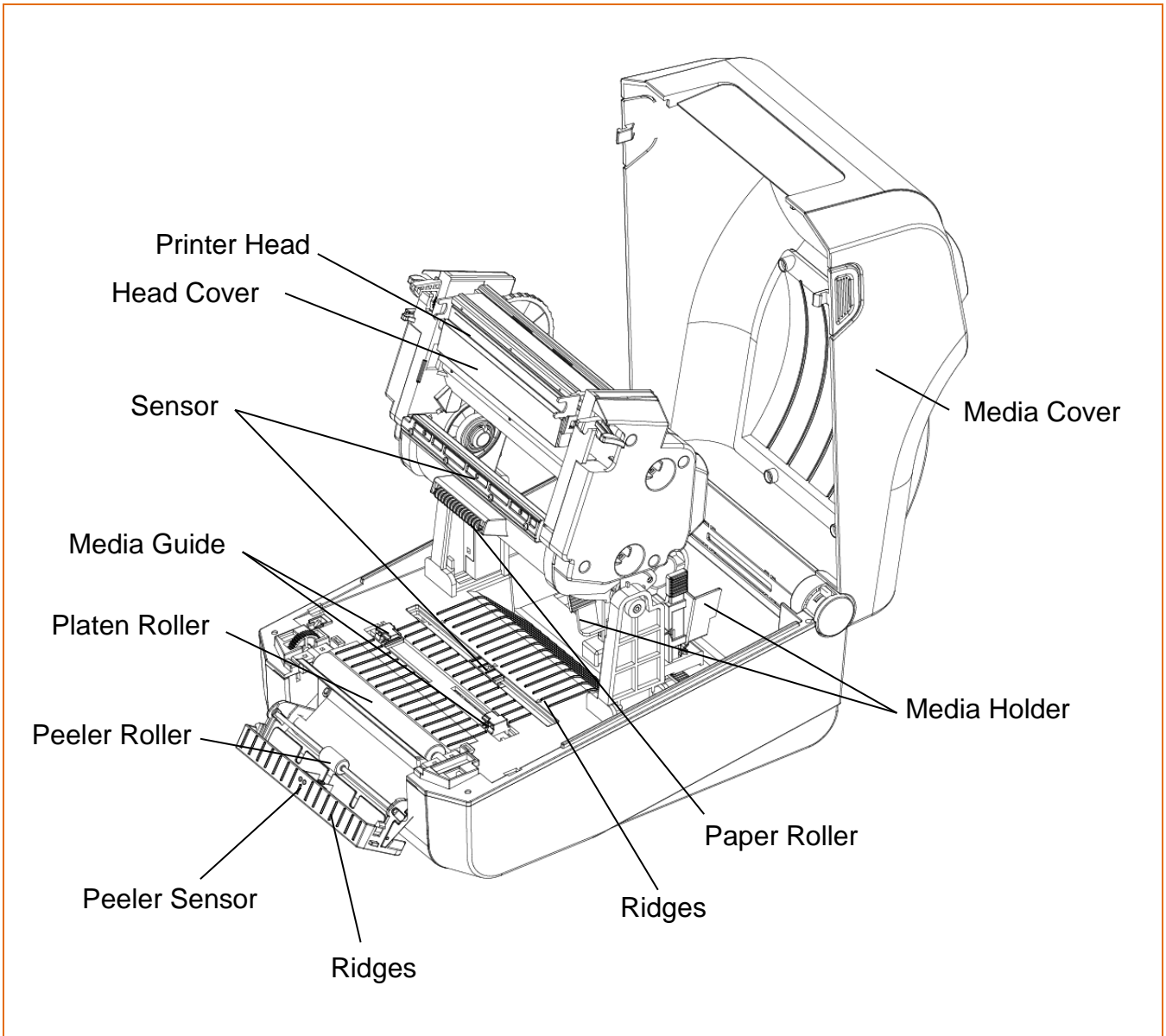

⚠ Caution



- Clean the parts when there is a degradation of performance in printing quality or media detection.
- After cleaning the parts, do not use the printer until the alcohol evaporates completely(1~2 min) and the printer has completely dried
- Be sure to use medical alcohol only. If not, it may cause printer damage.

6-3 Replacing Roller

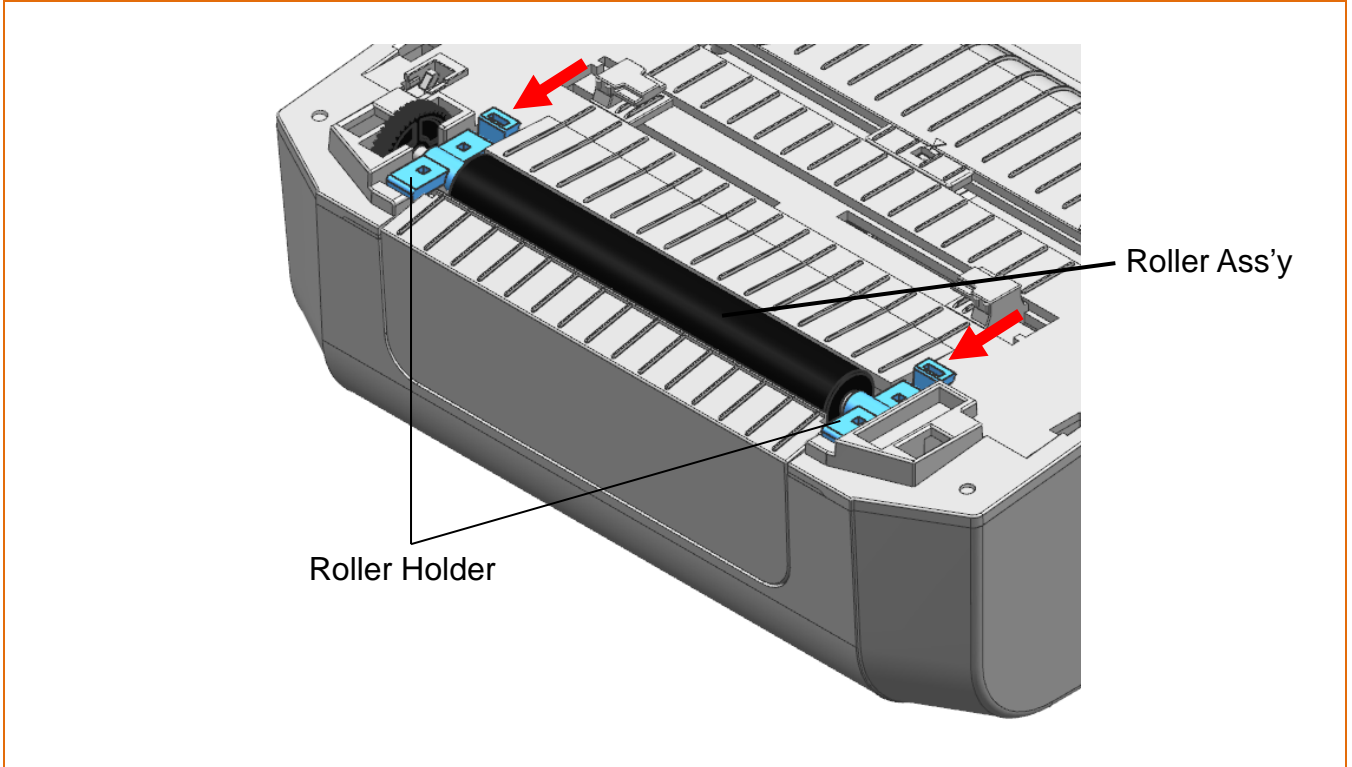
- 1) Open the media cover and ribbon assembly, and remove the media.
- 2) Pull the roller holders and separate the roller assembly.



- 3) Assemble new roller assembly in reverse order.

 Caution	Make sure to turn the printer power off prior to replacing.
 Warning	Do not touch heated area of print-head when replacing roller. This can cause serious damage and bodily injury.

7. Appendix

7-1 Specifications

Item		Description
Printing	Printing Method	Thermal Transfer / Direct Thermal Printing
	Dot Density	203 dpi (8 dot/mm)
	Printing Width	Max. 104 mm (Max. 4.09")
	Printing Speed	Max. 127 mm/sec (Max. 5ips)
Media	Roll Width	15 ~ 118 mm (0.59 ~ 4.64")
	Roll	Max 127 mm (Max. 5")
	Core	25.4 ~ 38 mm (1 ~ 1.5")
Ribbon	Length / Width	Max 300m / 33 ~ 110mm(1.3~4.3")
	Type(Outside)	Wax, Wax/Resin, Resin
	Core	0.5" / 1"
AC/DC Adapter	SMPS Input Voltage	AC 100 - 240V
	Frequency	50/60 Hz
	SMPS Output Voltage	DC 24V ±5%
	SMPS Output Current	2.5A
Usage Conditions	Temperature	0 ~ 40 °C (Operating) -20 ~ 60 °C (Storage)
	Humidity (except for media)	10 ~ 80 % RH (Operating) 10 ~ 90 % RH (Storage)



Note

Print speed may vary depending on the data transfer speed and the combination of command.



Caution

- In case of emergency, turn off the power to cut the connection.
- The power cord must be grounded to ensure safety and reduce electromagnetic interference.

7-2 Label Types

- The label types used with this printer are as follows.
 - Control Labels: PET
 - Other Labels: PET

