



Questo manuale d'istruzione è fornito da trovaprezzi.it. Scopri tutte le offerte per [Custom Q3X](#) o cerca il tuo prodotto tra le [migliori offerte di Macchine per Ufficio](#)

USER MANUAL

Q3X

CUSTOM[®]

CUSTOM S.p.A.
Via Berettine 2/B
43010 Fontevivo (PARMA) - Italy
Tel. : +39 0521-680111
Fax : +39 0521-610701
http: www.custom.biz

Customer Service Department:
Email : support@custom.it

© 2015 CUSTOM S.p.A. – Italy.
All rights reserved. Total or partial reproduction of this manual in whatever form, whether by printed or electronic means, is forbidden. While guaranteeing that the information contained in it has been carefully checked, CUSTOM S.p.A. and other entities utilized in the realization of this manual bear no responsibility for how the manual is used. Information regarding any errors found in it or suggestions on how it could be improved are appreciated. Since products are subject to continuous check and improvement, CUSTOM S.p.A. reserves the right to make changes in information contained in this manual without prior notification.

The pre-installed multimedia contents are protected from Copyright CUSTOM S.p.A. Other company and product names mentioned herein may be trademarks of their respective companies. Mention of third-party products is for informational purposes only and constitutes neither an endorsement nor a recommendation. CUSTOM S.p.A. assumes no responsibility with regard to the performance or use of these products.

THE IMAGES USED IN THIS MANUAL ARE USED AS AN ILLUSTRATIVE EXAMPLES. THEY COULDN'T REPRODUCE THE DESCRIBED MODEL FAITHFULLY.

UNLESS OTHERWISE SPECIFIED, THE INFORMATION GIVEN IN THIS MANUAL ARE REFERRED TO ALL MODELS IN PRODUCTION AT THE ISSUE DATE OF THIS DOCUMENT.

GENERAL INSTRUCTIONS

CUSTOM S.p.A. declines all responsibility for accidents or damage to persons or property occurring as a result of tampering, structural or functional modifications, unsuitable or incorrect installations, environments not in keeping with the equipment's protection degree or with the required temperature and humidity conditions, failure to carry out maintenance and periodical inspections and poor repair work.

GENERAL SAFETY INFORMATION

Your attention is drawn to the following actions that could compromise the characteristics of the product:

- Read and retain the instructions which follow.
- Follow all indications and instructions given on the device.
- Make sure that the surface on which the device rests is stable. If it is not, the device could fall, seriously damaging it.
- Make sure that the device rests on a hard (non-padded) surface and that there is sufficient ventilation.
- Do not fix indissolubly the device or its accessories such as power supplies unless specifically provided in this manual.
- When positioning the device, make sure cables do not get damaged.
- [Only OEM equipment] The equipment must be installed in a kiosk or system that provides mechanical, electrical and fire protection.
- The mains power supply must comply with the rules in force in the Country where you intend to install the equipment.
- Make sure that there is an easily-accessible outlet with a capacity of no less than 10A closely to where the device is to be installed.
- Make sure the power cable provided with the appliance, or that you intend to use is suitable with the wall socket available in the system.
- Make sure the electrical system that supplies power to the device is equipped with a ground wire and is protected by a differential switch.
- Before any type of work is done on the machine, disconnect the power supply.
- Use the type of electrical power supply indicated on the device label.
- These devices are intended to be powered by a separately certified power module having an SELV, non-energy hazardous output. (IEC60950-1 second edition).
- [Only POS equipment] The energy to the equipment must be provided by power supply approved by CUSTOM S.p.A.
- Take care the operating temperature range of equipment and its ancillary components.
- Do not block the ventilation openings.
- Do not insert objects inside the device as this could cause short-circuiting or damage components that could jeopardize printer functioning.
- Do not carry out repairs on the device yourself, except for the normal maintenance operations given in the user manual.
- The equipment must be accessible on these components only to trained, authorized personnel.
- Periodically perform scheduled maintenance on the device to avoid dirt build-up that could compromise the correct, safe operation of the unit.
- Do not touch the head heating line with bare hands or metal objects. Do not perform any operation inside the printer immediately after printing because the head and motor tend to become very hot.
- Use consumables approved by CUSTOM S.p.A.



THE CE MARK AFFIXED TO THE PRODUCT CERTIFY THAT THE PRODUCT SATISFIES THE BASIC SAFETY REQUIREMENTS.

The device is in conformity with the essential Electromagnetic Compatibility and Electric Safety requirements laid down in Directives 2006/95/CE and 2004/108/CE inasmuch as it was designed in conformity with the provisions laid down in the following Standards:

- EN 55022 Class B (*Limits and methods of measurements of radio disturbance characteristics of Information Technology Equipment*)
- EN 55024 (*Information Technology Equipment – Immunity characteristics – Limits and methods of measurement*)
- EN 60950-1 (*Safety of information equipment including electrical business equipment*)

The device is in conformity with the essential requirements laid down in Directives 1999/05/CE about devices equipped with intentional radiators. The Declaration of Conformity and other available certifications can be request to support@custom.it please providing the correct part number shown on product label or in the invoice.



GUIDELINES FOR THE DISPOSAL OF THE PRODUCT

The crossed-out rubbish bin logo means that used electrical and electronic products shall NOT be mixed with unsorted municipal waste. For more detailed information about recycling of this product, refer to the instructions of your country for the disposal of these products.

- Do not dispose of this equipment as miscellaneous solid municipal waste, but arrange to have it collected separately.
- The re-use or correct recycling of the electronic and electrical equipment (EEE) is important in order to protect the environment and the wellbeing of humans.
- In accordance with European Directive WEEE 2002/96/EC, special collection points are available to which to deliver waste electrical and electronic equipment and the equipment can also be handed over to a distributor at the moment of purchasing a new equivalent type.
- The public administration and producers of electrical and electronic equipment are involved in facilitating the processes of the re-use and recovery of waste electrical and electronic equipment through the organisation of collection activities and the use of appropriate planning arrangements.
- Unauthorised disposal of waste electrical and electronic equipment is punishable by law with the appropriate penalties.



The format used for this manual improves use of natural resources reducing the quantity of necessary paper to print this copy.

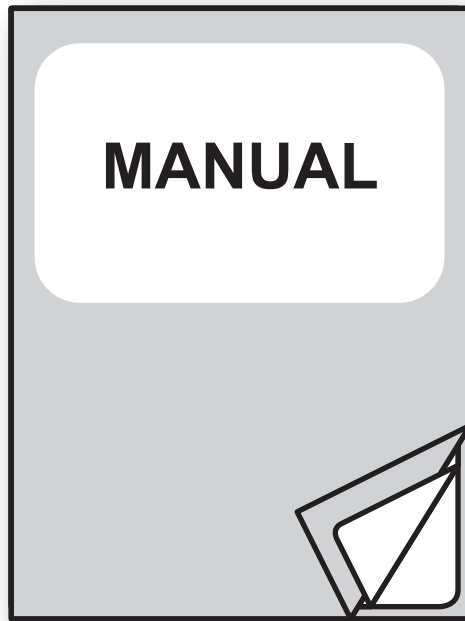

For details on the commands,
refer to the manual with code **77200000001400**

TABLE OF CONTENTS

1	INTRODUCTION	9
1.1	Document structure	9
1.2	Explanatory notes used in this manual	9
2	DESCRIPTION	11
2.1	Box contents	11
2.2	Device components	12
2.3	Product label	14
2.4	Key functions: power up	15
2.5	Key functions: standby	16
2.6	Status messages	17
3	INSTALLATION	19
3.1	Connections	19
3.2	Pinout	20
3.3	Driver and SDK	23
4	OPERATION	25
4.1	Switch the device ON/OFF	25
4.2	Opening cover	26
4.3	Loading the paper roll	27
4.4	Pairing with Bluetooth® devices	28
5	CONFIGURATION	33
5.1	Configuration mode	33
5.2	Setup report	34
5.3	Device status	37
5.4	Printer parameters	38
5.5	Hexadecimal dump	42
6	MAINTENANCE	43
6.1	Paper jam	43
6.2	Planning of cleaning operations	44
6.3	Cleaning	45
6.4	Upgrade firmware	49

7	SPECIFICATION	51
7.1	Hardware specifications	51
7.2	Character specifications	54
7.3	Device dimensions	55
7.4	Power supply dimensions cod. 961GE020000001	56
7.5	Power supply dimensions cod. 963GE020000003 (optional)	57
7.6	Paper specification	58
7.7	Character sets in CUSTOM/POS emulation	59
8	CONSUMABLES	61
9	ACCESSORIES	63
10	ALIGNMENT	65
10.1	Enable alignment	66
10.2	Calibration	68
10.3	Alignment parameters	70
10.4	Printing area	73
11	TECHNICAL SERVICE	75

1 INTRODUCTION

1.1 Document structure

This document includes the following chapters:

1	INTRODUCTION	information about this document
2	DESCRIPTION	general description of device
3	INSTALLATION	information required for a correct installation of the device
4	OPERATION	information required to make the device operative
5	CONFIGURATION	description of the configuration parameters of the device
6	MAINTENANCE	information for a correct periodic maintenance
7	SPECIFICATION	technical specification for the device and its accessories
8	CONSUMABLES	description and installation of the available consumables for the device
9	ACCESSORIES	description and installation of the available accessories for the device
10	ALIGNMENT	information required for managing the paper alignment
11	TECHNICAL SERVICE	information required for contacting the technical service

1.2 Explanatory notes used in this manual

NOTE:

Gives important information or suggestions relative to the use of the device

ATTENTION:

Gives information that must be carefully followed to guard against damaging the device

DANGER:

Gives information that must be carefully followed to guard against operator injury or damage

2 DESCRIPTION

2.1 Box contents

Remove the device from its carton being careful not to damage the packing material so that it may be re-used if the device is to be transported in the future.

Make sure that all the components illustrated below are present and that there are no signs of damage. If there are, contact Customer Service.

1. Device
2. Short guide
3. AC adapter
4. AC Power cable

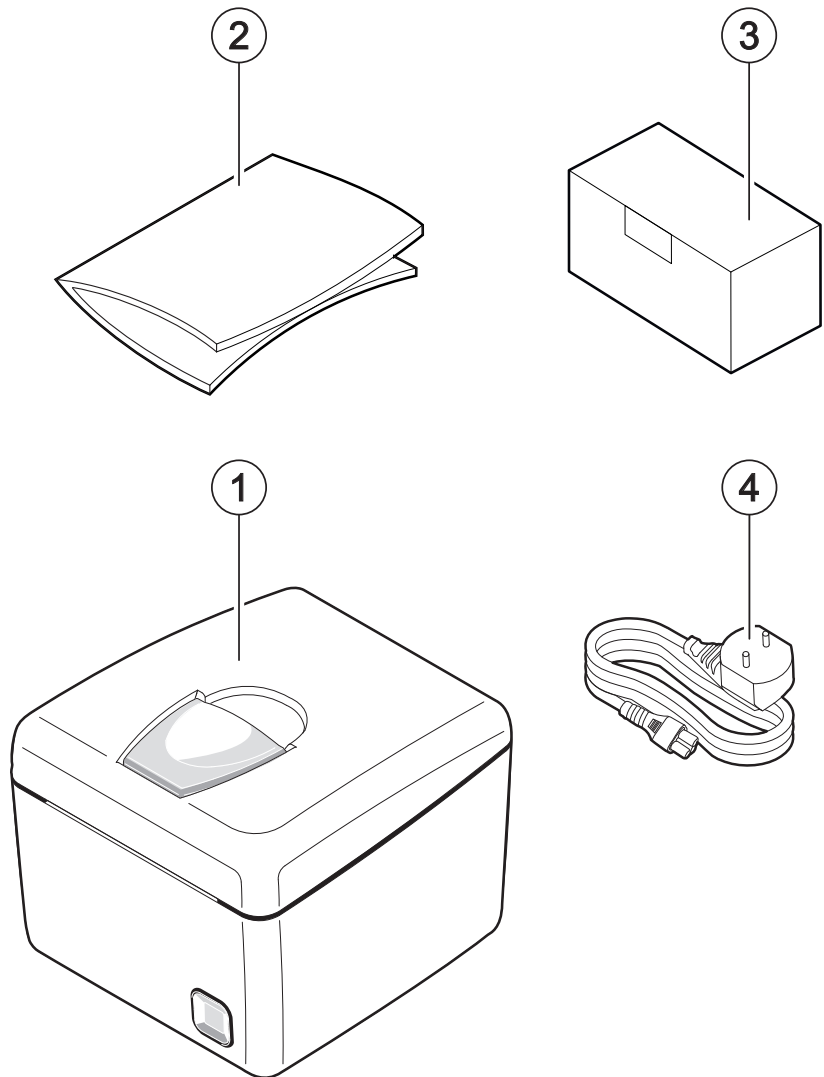

- Open the device packaging.
- Remove the packing frame content and remove the packing frame.
- Take out the device.
- Keep the box, trays and packing materials in the event the device must be transported/shipped in the future.

2.2 Device components

External view

1. Paper compartment cover
2. Opening lever for paper compartment
3. Paper out
4. Status LED
5. FEED key
6. ON/OFF key
7. Power supply port
8. Drawer port
9. USB interface port
10. RS232 serial interface port
11. WiFi board or Bluetooth® (only WiFi models or Bluetooth®)

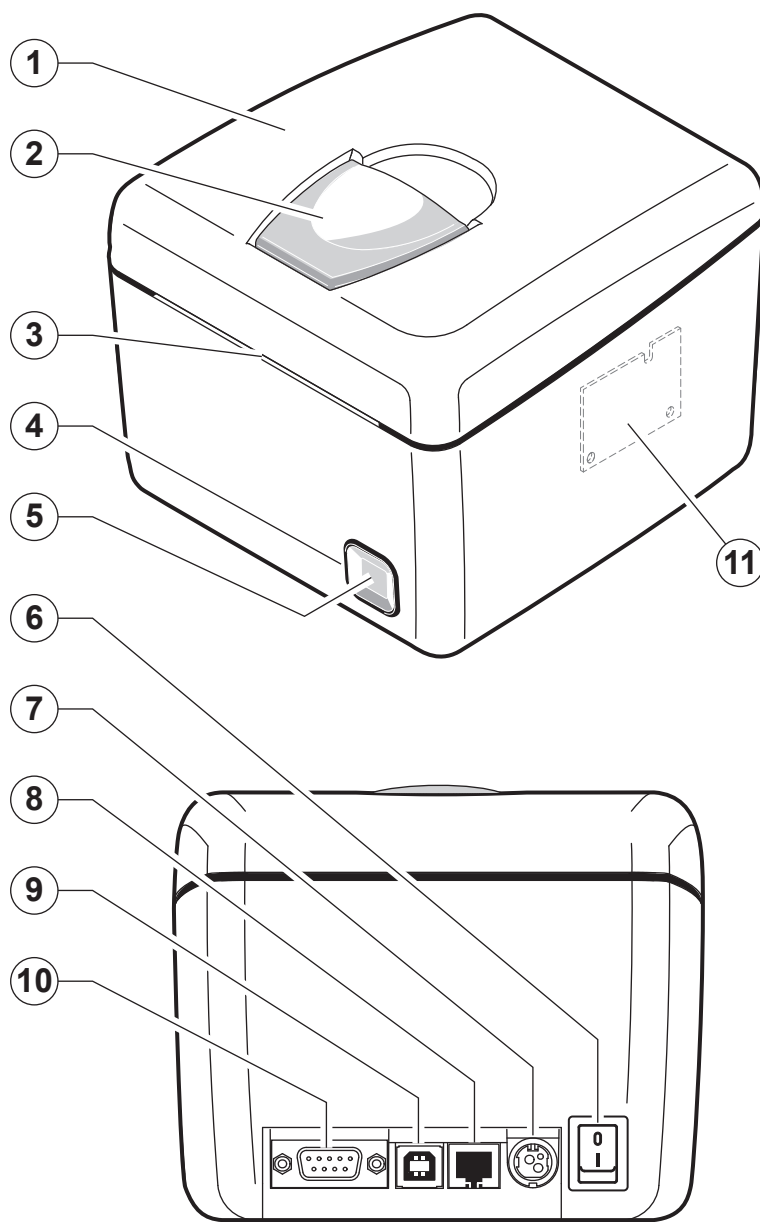

Internal view

1. Temperature sensor for the print-head
2. Sensor for paper and black mark detection
3. Sensor for cover open

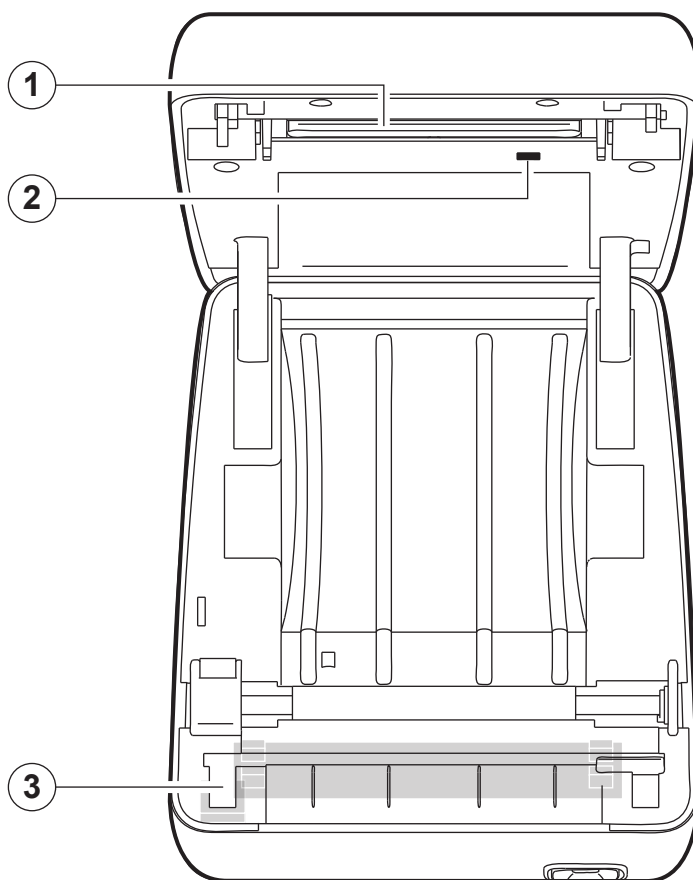

2.3 Product label

PC = Product code (14 digits)
SN = Serial number
HW = Hardware release

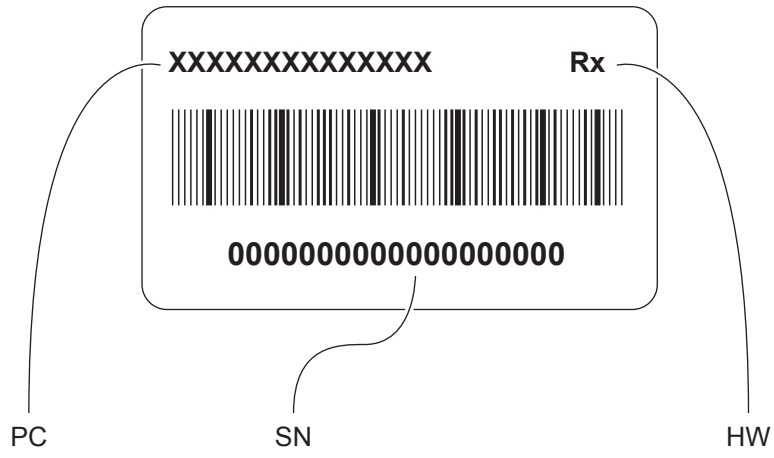

2.4 Key functions: power up

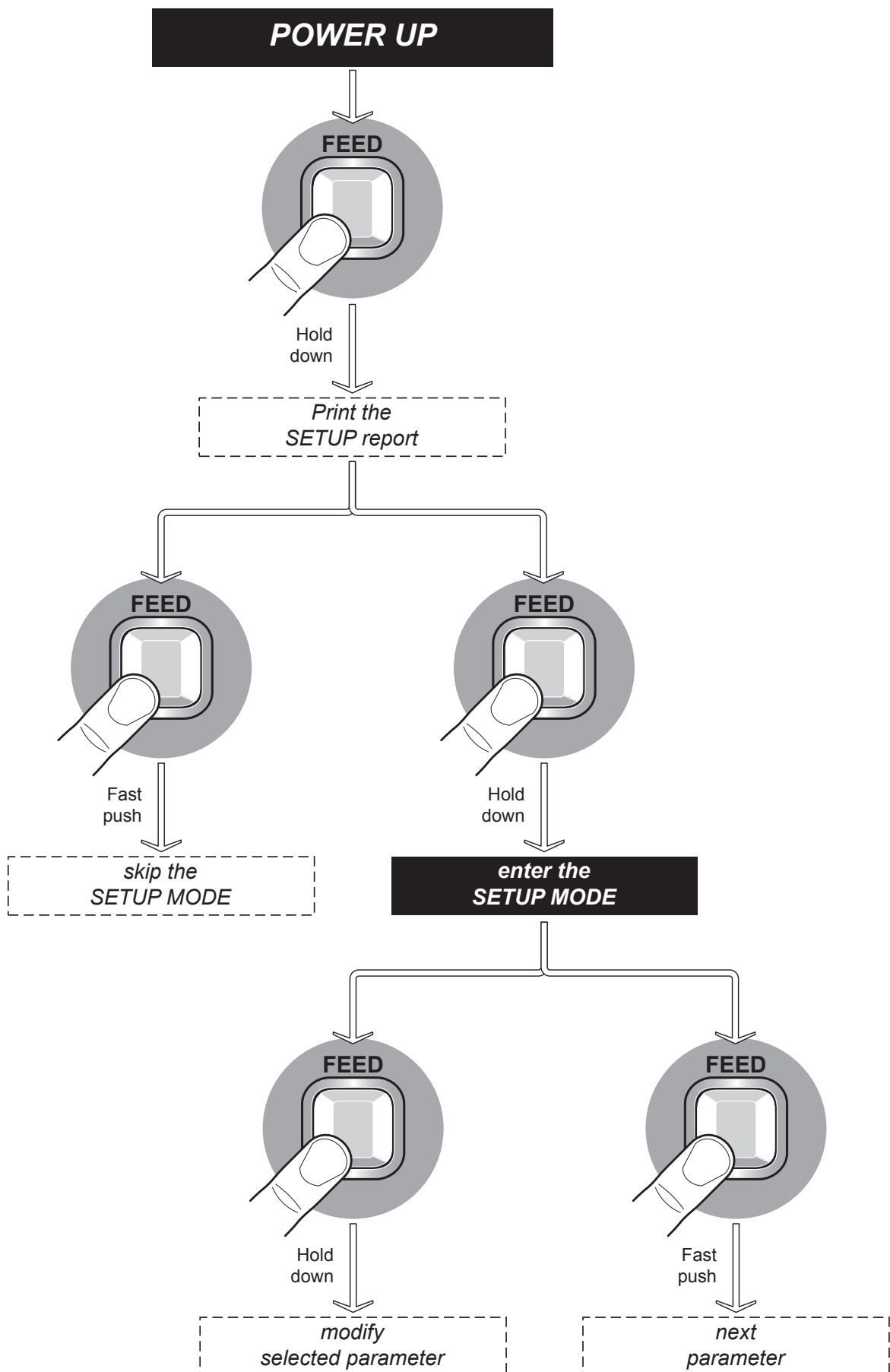



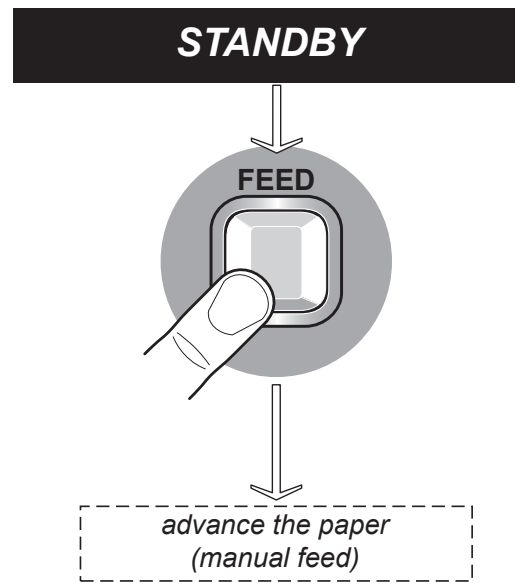



2.5 Key functions: standby











2.6 Status messages

The status LED indicates hardware status of device. Given in the table below are the various led signals and the corresponding device status.

Q3X (standard models)

STATUS LED		DESCRIPTION	
-		OFF	DEVICE OFF
R/G/B		ON	DEVICE ON: READY MODE
BLUE NOTIFICATION STATUS		ON	DEVICE ON: NO ERROR
BLUE COMMUNICATION STATUS		x 1	RECEIVE DATA
		x 2	RECEPTION ERRORS (PARITY, FRAME ERROR, OVERRUN ERROR)
		x 3	COMMAND NOT RECOGNIZED
		x 4	COMMAND RECEPTION TIME OUT
YELLOW RECOVERABLE ERROR		x 2	HEADING OVER TEMPERATURE
		x 3	PAPER END
		x 5	POWER SUPPLY VOLTAGE INCORRECT
RED UNRECOVERABLE ERROR		x 6	COVER OPEN
		x 3	RAM ERROR
		x 4	EEPROM ERROR
		x 5	CUTTER ERROR

Q3X (WiFi models, Bluetooth® models)

STATUS LED		DESCRIPTION	
-		OFF	DEVICE OFF
WHITE/BLU		ON	DEVICE ON: READY MODE. CABLE COMMUNICATION ACTIVE AND/OR CABLE COMMUNICATION WiFi OR BLUETOOTH® DEACTIVATED
BLUE COMMUNICATION STATUS		x 1	RECEIVE DATA
		x 2	RECEPTION ERRORS (PARITY, FRAME ERROR, OVERRUN ERROR)
		x 3	COMMAND NOT RECOGNIZED
		x 4	COMMAND RECEPTION TIME OUT
YELLOW NOTIFICATION STATUS		x 2	HEADING OVER TEMPERATURE
		x 3	PAPER END
		x 5	POWER SUPPLY VOLTAGE INCORRECT
RED UNRECOVERABLE ERROR		x 6	COVER OPEN
		x 3	RAM ERROR
		x 4	EEPROM ERROR
YELLOW WiFi/ BLUETOOTH® STATUS		x 5	CUTTER ERROR
		x 1	INITIALIZATION MODULES WiFi OR INITIALIZATION MODULES BLUETOOTH®
GREEN WiFi/ BLUETOOTH® STATUS		ON	DEVICE ON: NO ERROR COMMUNICATION WiFi AND BLUETOOTH® ACTIVE, WAITING FOR OPENING SOCKET FOR WiFi OR PAIRING FOR BLUETOOTH®
VIOLET WiFi/ BLUETOOTH® STATUS		ON	WIRELESS CONNECTION ACTIVE.

3 INSTALLATION

3.1 Connections

The following figure shows the possible connections for the device.

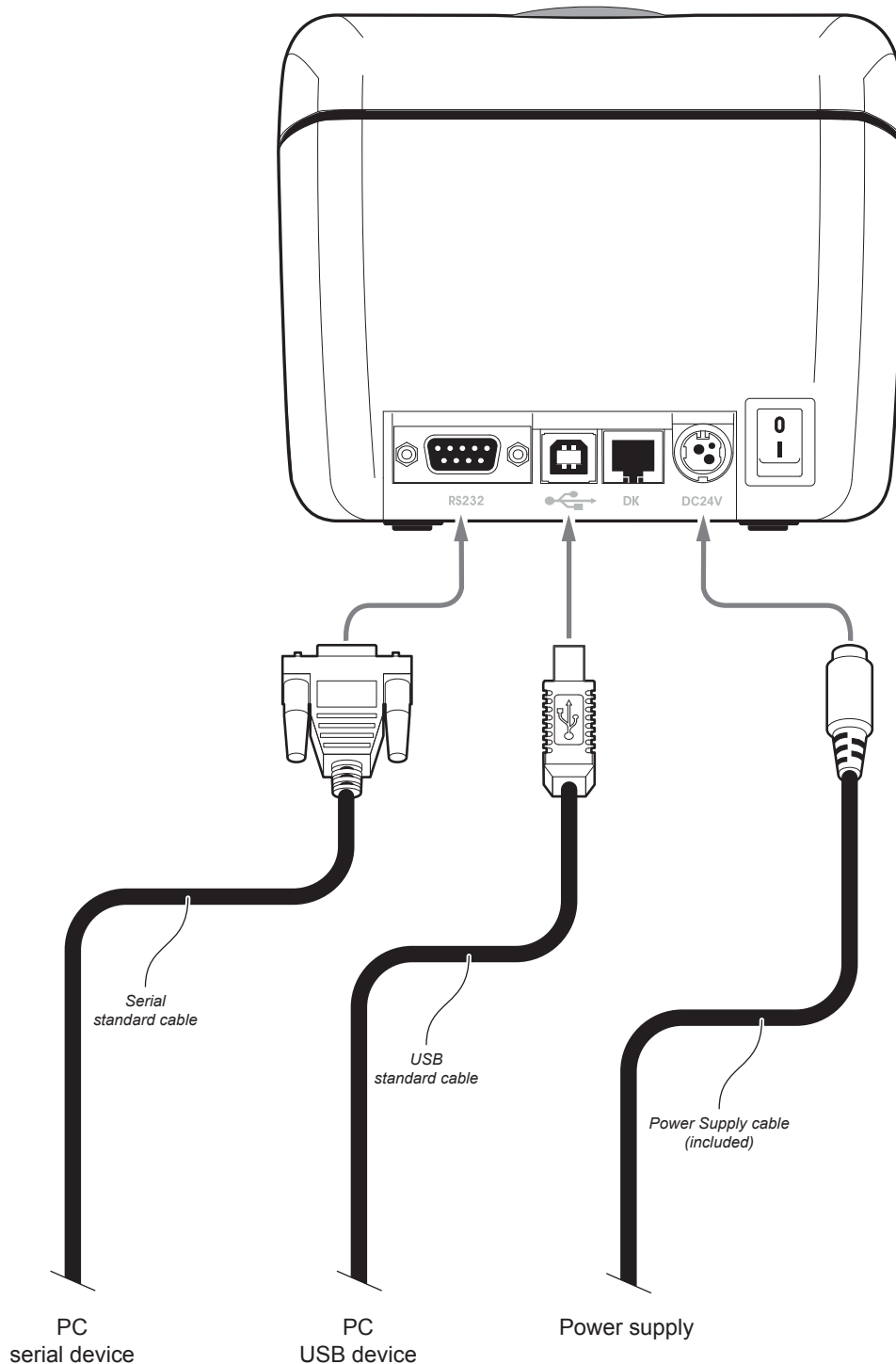

ATTENTION: In some conditions, we recommend the installation of a ferrite core on the power supply cable.

NOTES: If serial and USB connectors are inserted, communication port is USB.

3.2 Pinout



POWER SUPPLY
Tripolar female connector

J12	1	+24 Vdc
	2	GND
	3	GND
	4	Frame GND

ATTENTION:
Respect power supply polarity.

NOTE:
Power supply cable
The following figure shows the connector pinout of the power supply cable for the device:

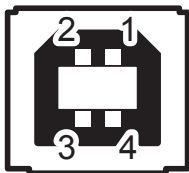
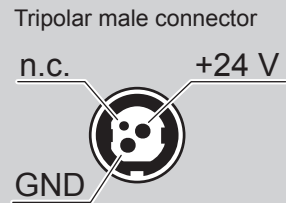
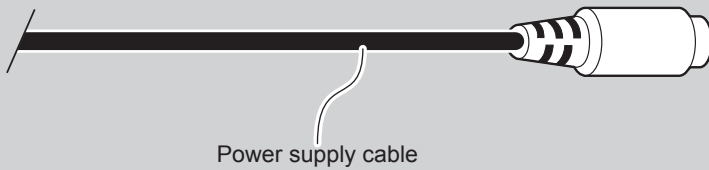

USB INTERFACE
Female USB type B connector

J2	1	USB0-VBUS	(in)
	2	D0 -	(in/out)
	3	D0 +	(in/out)
	4	GND	
	SH1	SHIELD	
	SH2	SHIELD	

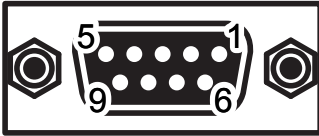

RS232 SERIAL INTERFACE

Female DB9 connector

J1	1	DTR	
	2	TX	During transmission, takes the values "0" and "1" depending on data.
	3	RX	During reception, takes the values "0" and "1" depending on data.
	4	n.c.	
	5	GND	
	6	DTR	When "1", device is power on.
	7	n.c.	
	8	RTS	When "1", device is ready to receive data
	9	n.c.	

NOTES:

Given the presence of the RS232 standard, logic value "0" corresponds to a voltage level of between +3Vdc and +15Vdc and logic value "1" corresponds to a voltage level of between -3Vdc and -15Vdc.

DEVICE > PC connection

The following picture shows an example of connections between the device and a personal computer using a 9 pin RS232 serial connectors:

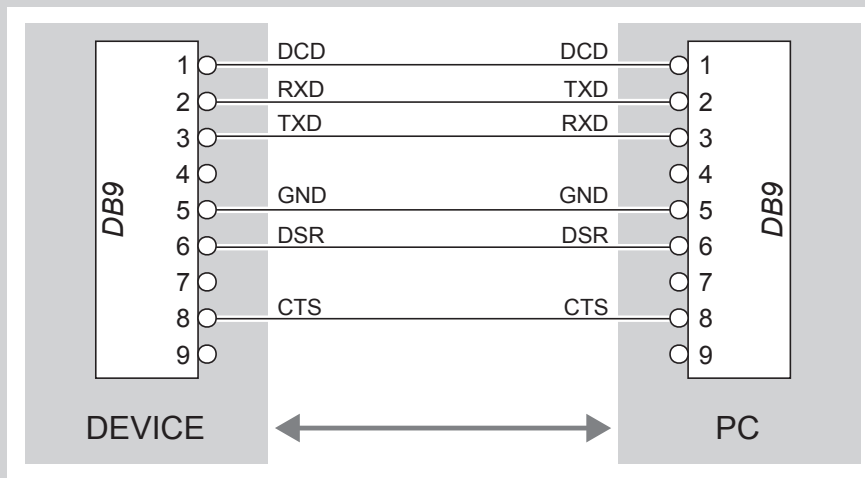

When use a serial cable, we recommend the installation of a ferrite core on the power supply cable.



DRAWER CONNECTOR

Female RJ12 connector

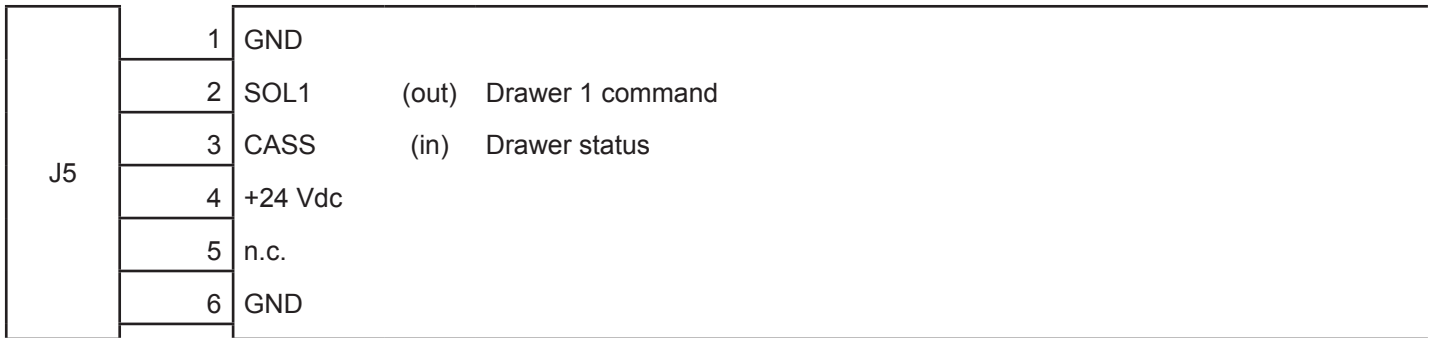

ATTENTION:

This device can manage drawers of different power supplies (6V, 12V, 18V, 24V). To prevent a current overload, check and set correctly the kind of cash drawer.

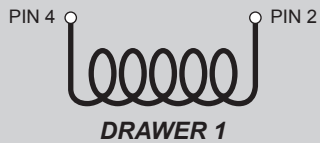

NOTE:

The solenoid of the drawer 1 must be connected from Pin 2 to Pin 4 on the drawer connector

NOTE:

DEVICE > CASH DRAWER (optional) connection

Use an optional adapter cable RJ12-Jack to connect the device to a cash drawer. Refer to the picture below for the connector pin signals

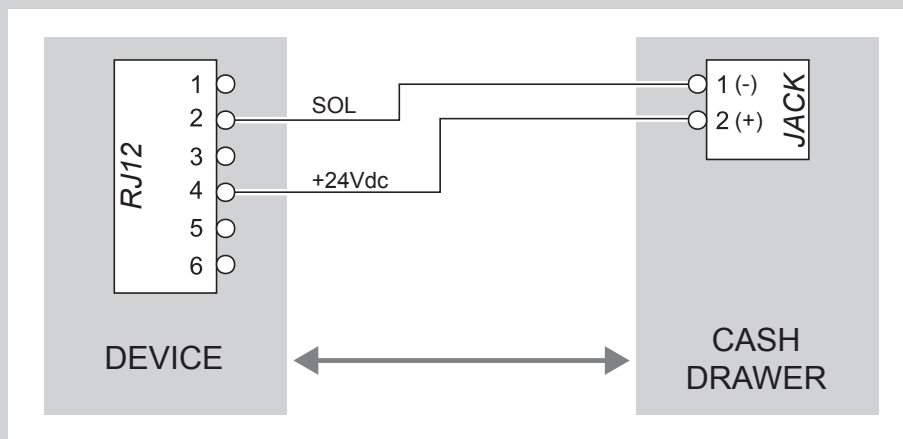

3.3 Driver and SDK

The drivers are available for the following operating system:

OPERATING SYSTEM	DESCRIPTION	INSTALLATION PROCEDURE
Windows	Driver for Windows XP	From the START menu, press Run and type-in the path where the SW was saved on your PC, then click OK. Follow the instructions that appear on the screen to install the driver.
	Driver for Windows VISTA (32/64bit)	
	Driver for Windows 7 (32/64bit)	
	Driver for Windows 8 (32/64bit)	
	Driver for Windows 8.1 (32/64bit)	
	Driver for OPOS	
Linux	(32/64bit)	Follow the instruction get back on the README.TXT file. You can find it in the software package downloaded in advance.
Android	SDK for CustomAndroidAPI	Extract the zipped folder to the destination path desired. Follow the instructions present in the software package that you downloaded on how to install and use the library.
iOS	SDK for CustomiOSApi	Extract the zipped folder to the destination path desired. Follow the instructions present in the software package that you downloaded on how to install and use the library.

NOTE:

All drivers can be found in the DOWNLOAD section of the web site www.custom.biz.

4 OPERATION

4.1 Switch the device ON/OFF

1

For printing receipts with wide black zones, we recommend to replace the included power supply with the optional power supply that provides a peak current higher for larger time intervals (see Technical specification for power supplies codes).

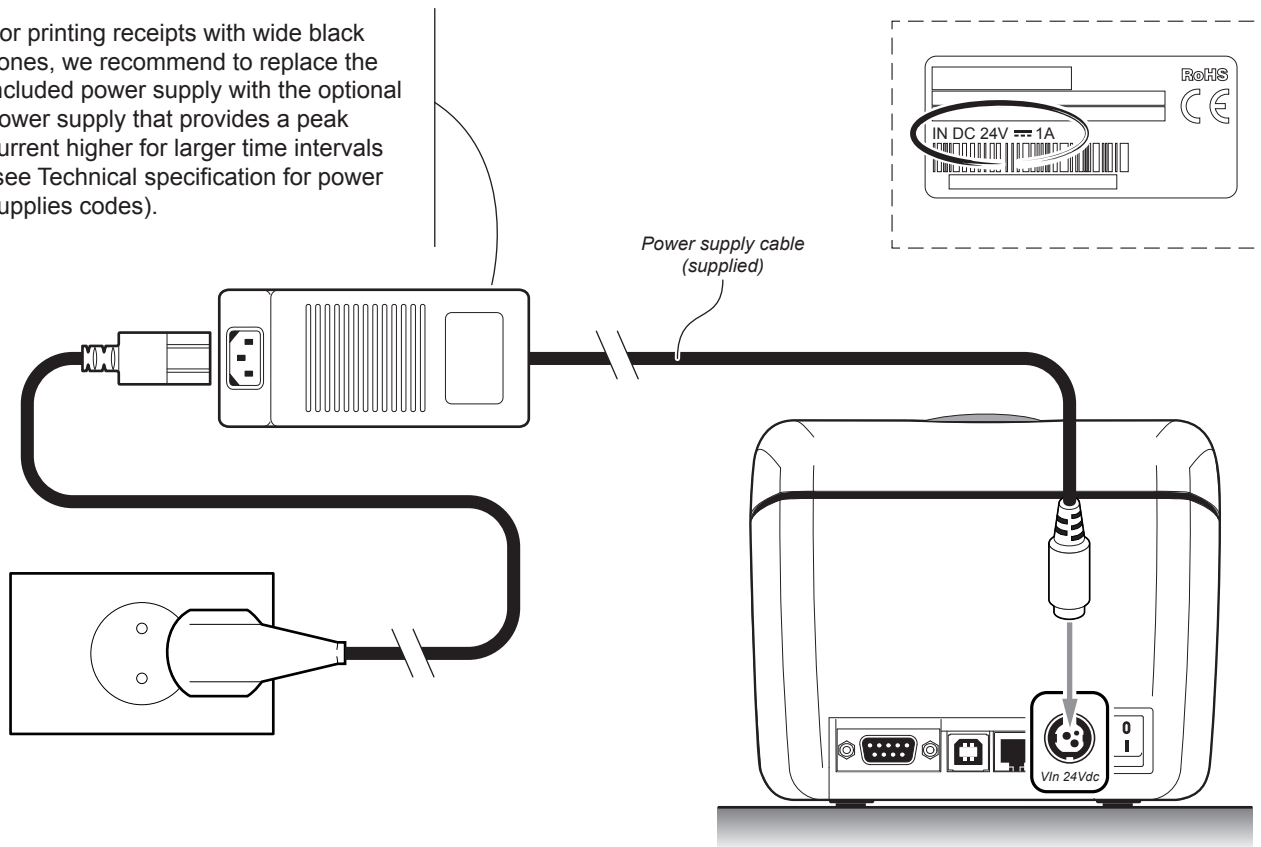

Connect the power adapter (supplied) to the device and the mains outlet.
Use the type of electrical power supply indicated on the label.

2

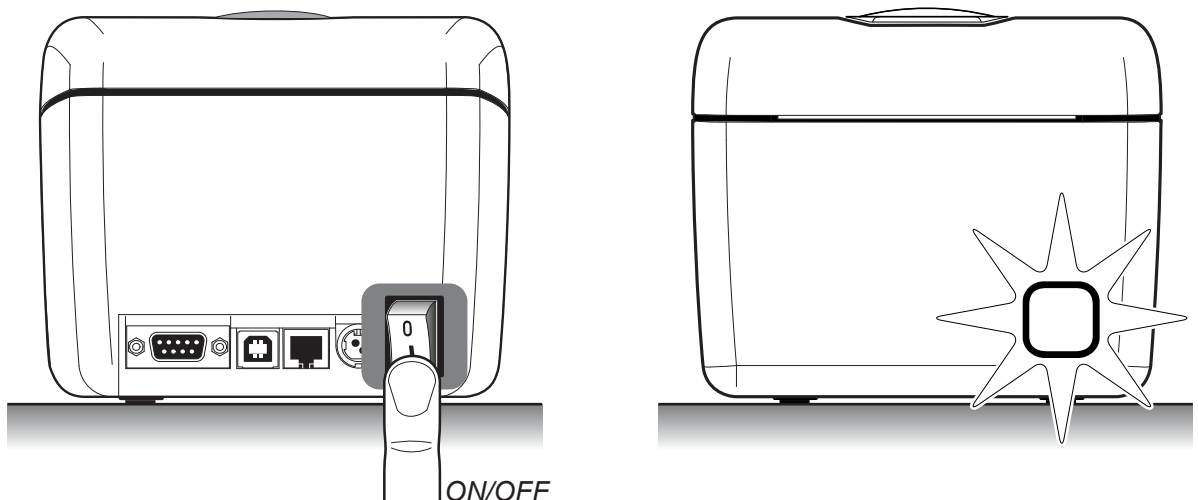

Switch device On pressing key ON/OFF, the indicator light is switched on and the device is ready.
Switch device Off pressing key ON/OFF.

4.2 Opening cover

1

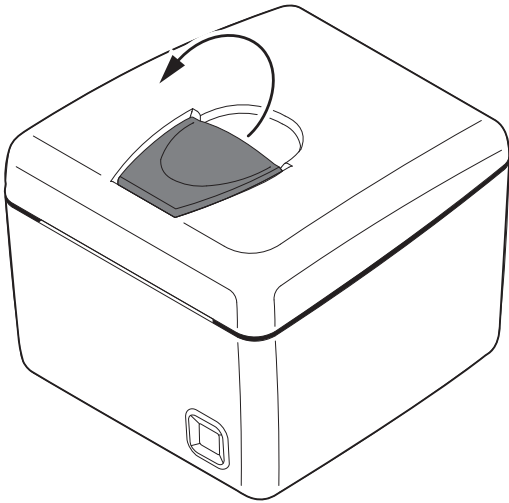

Lift the opening lever for the cover.

2

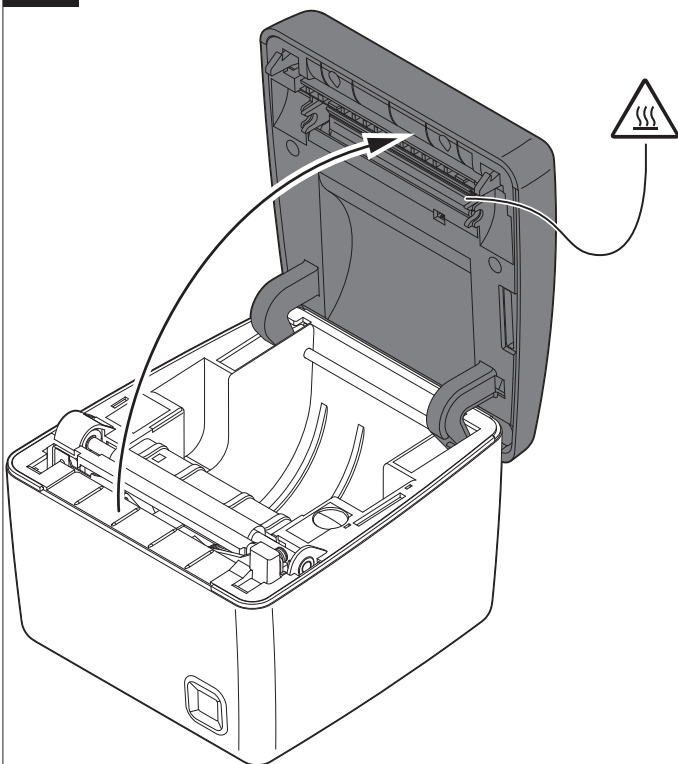

Open the device cover.

4.3 Loading the paper roll

To change the paper proceed as follows. At every change of paper, check inside the device to locate and remove any scraps of paper.

1

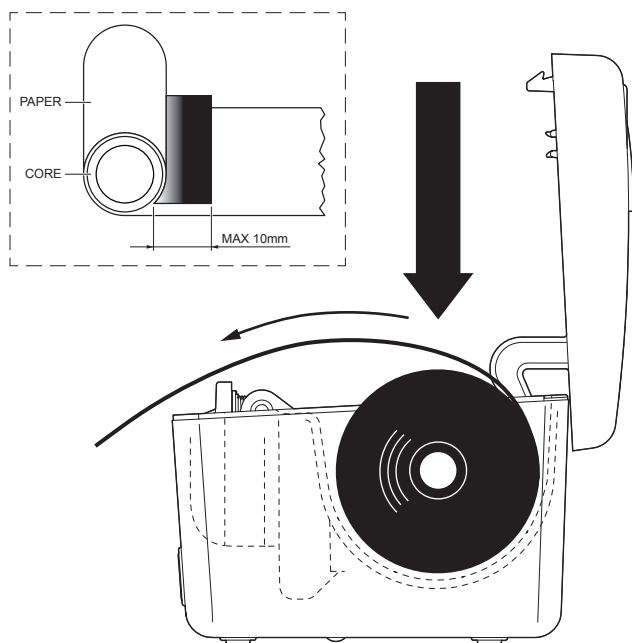

Open the device cover (see par. 4.2).
Place the roll in the paper compartment and pull out the paper for a few centimetres. Use paper rolls in accordance with the measure for the double roll up of the paper at the roll core.

2

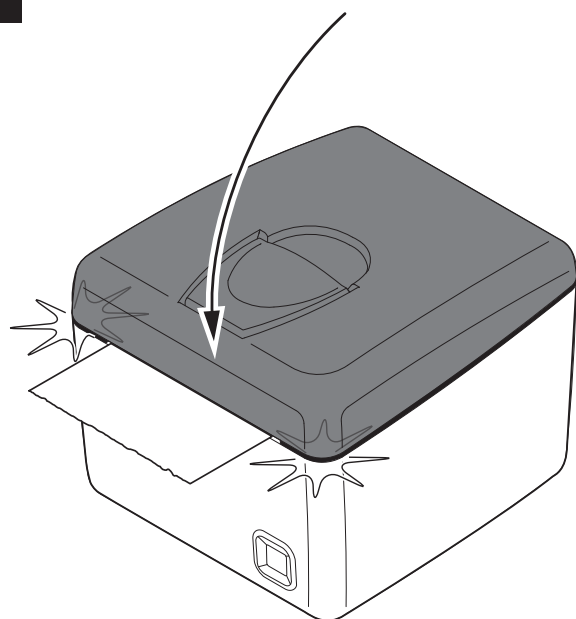

Close the device cover and wait until the paper is automatically loaded .

4.4 Pairing with Bluetooth® devices

The Bluetooth® connectivity of Q3X allows the wireless printing from a PC (ex. using a text editor or third-part software) or from a mobile device Android, Apple® and Windows Phone after installing the application “CustomPrint”.

To perform the wireless printing with a device equipped with Bluetooth® connectivity is needed to pair with Q3X.

NOTE: The screen images used in this paragraph may be different from the screens that appear on the device used for printing and may vary depending on the version of the operating system Android, Windows Phone and iOS®.

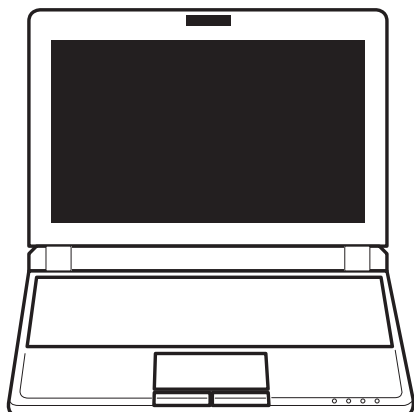
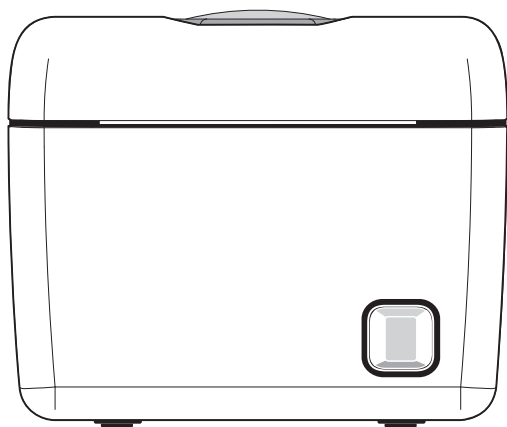

PC connection

Proceed as follows

1. Make sure that the “Wireless” parameter of the printer is set to ON (see par. 5.4) and the printer is ON.
- 2.
3. Execute from the PC the search for Bluetooth® devices available.
4. If Q3X is in the range of your PC, it is identified as a Bluetooth® device Q3x_<mac address>.
5. Select from PC the Bluetooth® device Q3x_<mac address> to set the pairing.
6. Enter the PIN for Q3X (1234).
7. Now you can print wireless from a PC on Q3X.

NOTE: Once the pairing between host and Q3X was made, no longer need to run it again even if communication is interrupted (power off, stand by, etc.).

Connecting to an Android device

Make sure that the “Wireless” parameter of the printer is set to ON (see par. 5.4) and the printer is on.

To pair with Q3X from an Android device, follow the instructions below:

1

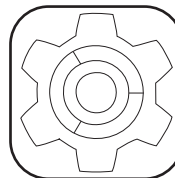

Tap the settings icon to open the menu.

2



Bluetooth

Tap the Bluetooth® item menu.

3

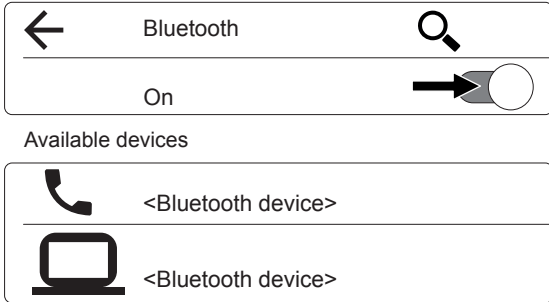

Enable the Bluetooth® to detect the device.

4

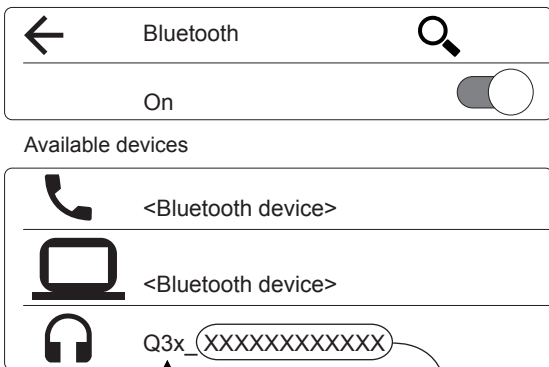

mac address (12 digit)

Select the device named "Q3x_XXXXXXXXXXXX".

5A

"Pairing BT" = Disabled

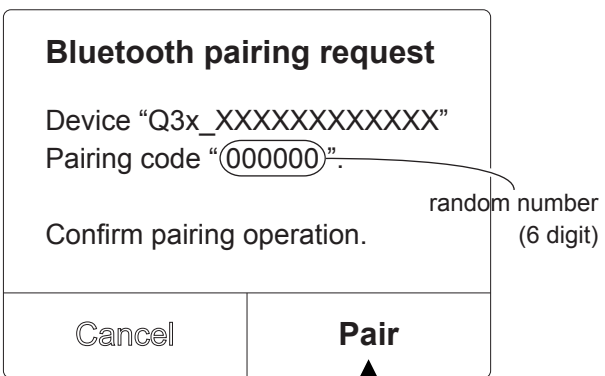

If "Pairing BT" parameter of the device is set to Disabled (see par. 5.4) confirm the pairing with "Q3x_XXXXXXXXXXXX".

5B

"Pairing BT" = Enabled

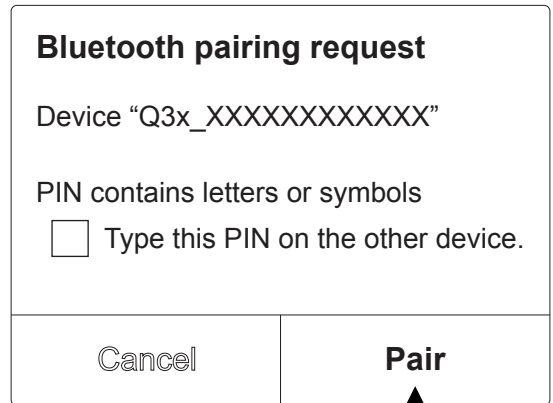

If "Pairing BT" parameter of the device is set to Enabled (see par. 5.4) enter the PIN '1234' to pair with "Q3x_XXXXXXXXXXXX".

6

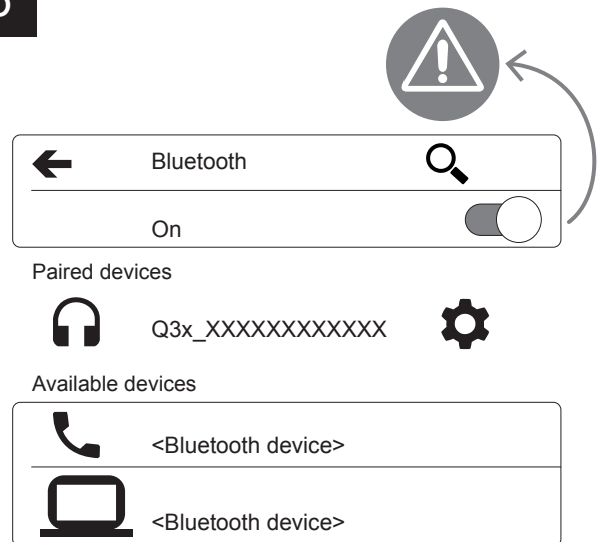

Once pairing is completed, do not turn off Bluetooth® communication. Otherwise, communication will be interrupted.

NOTE:

To print on an Android device install the APP "Custom-Print". Is available in the download area of the web site www.custom.biz the link to download the application.

Connecting to an iOS® device

Make sure that the “Wireless” parameter of the printer is set to ON (see par. 5.4) and the printer is on.

To pair with Q3X from an Apple® device, follow the instructions below:

1

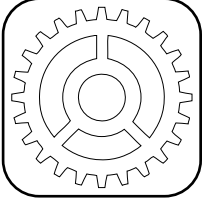

Tap the settings icon to open the menu.

2

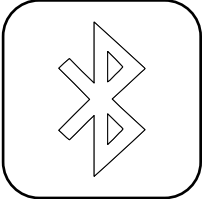

Tap the Bluetooth® icon to open the menu.

3

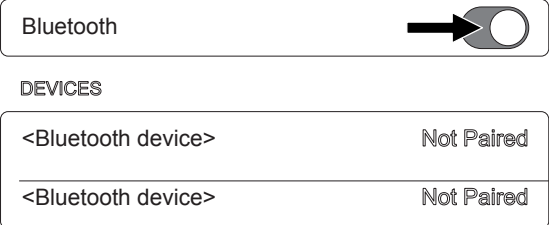

Enable the Bluetooth® to detect the device.

4

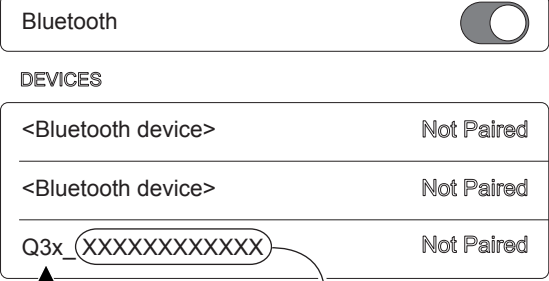

Select the device named “Q3x_XXXXXXXXXXXX”.

mac address (12 digit)

5

Bluetooth Pairing Request

“Q3x_XXXXXXXXXXXX” would like to pair with your <device>. Confirm that the code “000000” is shown on “Q3x_XXXXXXXXXXXX”.

random number (6 digit)

Cancel
Pair

Confirm the pairing with “Q3x_XXXXXXXXXXXX”.

6

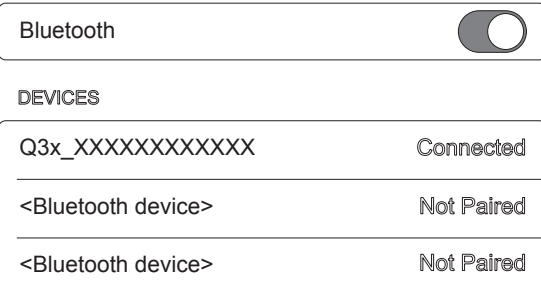
Once pairing is completed, do not turn off Bluetooth® communication. Otherwise, communication will be interrupted.

NOTE:

If “BT AutoReconnect” parameter of the printer is set to “Disabled” (see par. 5.4) the pairing function must always be performed whenever the communication is interrupted (power off, stand by, etc.)

NOTE:

To print on an Apple® device install the APP “Custom-Print”. Is available in the download area of the web site www.custom.biz the link to download the application.

Connecting to a Widows Phone

Make sure that the “Wireless” parameter of the printer is set to ON (see par. 5.4) and the printer is on.

To pair with Q3X from a Windows Phone device, follow the instructions below:

1

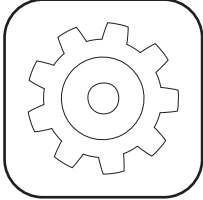

Tap the settings icon to open the menu.

2



Bluetooth

Tap the Bluetooth® icon to open the menu.

3

Bluetooth Status On

Devices

<Bluetooth device>	Not Paired
<Bluetooth device>	Not Paired

Enable the Bluetooth® to detect the device.

4

Bluetooth Status On

Devices

<Bluetooth device>	Not Paired
<Bluetooth device>	Not Paired
Q3x_XXXXXXXXXXXX	Not Paired

mac address (12 digit)

Select the device named “Q3x_XXXXXXXXXXXX”.

5A “Pairing BT” = Disabled

Pairing accessory

Make sure that this PIN “000000” matches the PIN that is displayed on “Q3x_XXXXXXXXXXXX”.

random number (6 digit)

ok cancel

If “Pairing BT” parameter of the device is set to Disabled (see par. 5.4) confirm the pairing with “Q3x_XXXXXXXXXXXX”.

5B “Pairing BT” = Enabled

Pairing Q3X_XXXXXXXXXXXX

Enter your PIN to connect.

done cancel

If “Pairing BT” parameter of the device is set to Enabled (see par. 5.4) enter the PIN ‘1234’ to pair with “Q3x_XXXXXXXXXXXX”.

6



Bluetooth Status On

Devices

Q3x_XXXXXXXXXXXX	Paired
<Bluetooth device>	Not paired
<Bluetooth device>	Not paired

Once pairing is completed, do not turn off Bluetooth® communication. Otherwise, communication will be interrupted.

NOTE:
To print on a Windows Phone device install the APP “CustomPrint”. Is available in the download area of the web site www.custom.biz the link to download the application.

5 CONFIGURATION

5.1 Configuration mode

To enter the configuration mode and print a SETUP report with the operating parameters of the device, proceed as follows.

1

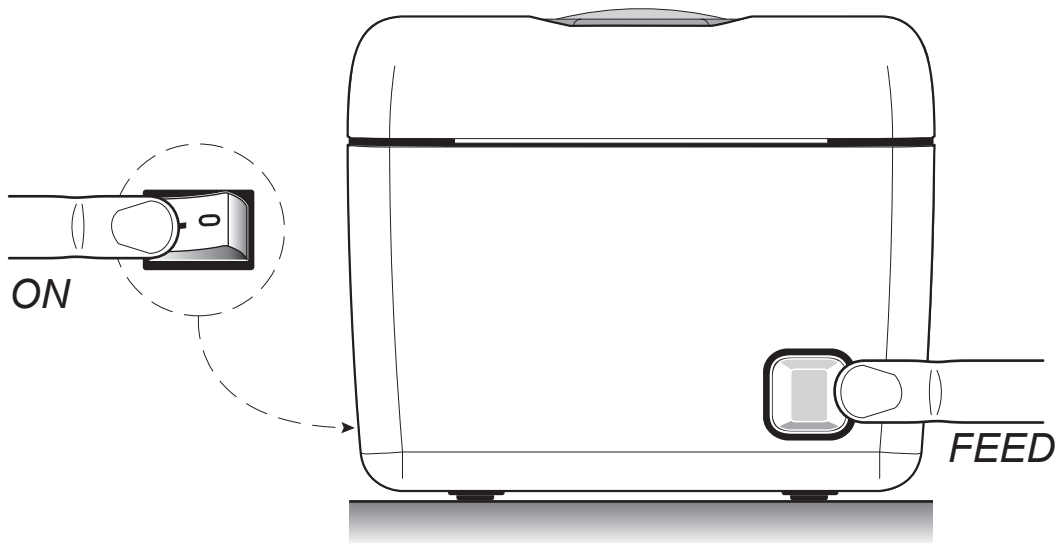

While pressing the FEED key,
switch on the device by pressing the ON/OFF key.

2

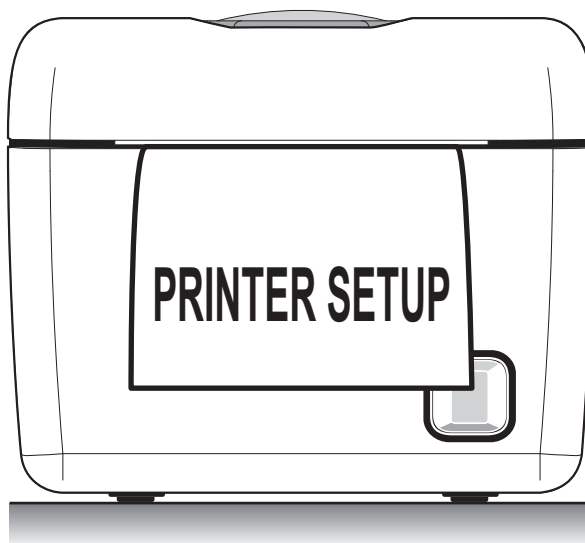

The device prints the report with the settings parameters.
Follow the instruction printed on paper to proceed with configuration procedure.

5.2 Setup report

The following figures show the setup reports of the device. The shown values for parameters are sample values; for the list and the description of device parameters see the following paragraphs.

Q3X (standard models)

<p><i>DEVICE NAME and FIRMWARE MODULES RELEASE</i></p>	}	<p>Q3X printer</p> <p>SCODE <code> - rel 2.22</p> <p>FCODE <code> - rel 1.00</p>
<p><i>DEVICE STATUS</i></p>	}	<p>PRINTER SETUP</p> <p>PRINTER TYPEQ3</p> <p>PRINTING HEAD TYPE.....KRB72</p> <p>INTERFACEUSB</p> <p>PROGRAM MEMORY TEST.....OK</p> <p>DYNAMIC RAM TEST.....OK</p> <p>EXTERNAL MEMORY TESTOK</p> <p>CUTTER TEST.....OK</p> <p>HEAD VOLTAGE [V] = 23.70</p> <p>HEAD TEMPERATURE [°C] = 25</p> <p>POWER ON COUNTER = 4</p> <p>PAPER PRINTED [cm] = 40</p> <p>CUT COUNTER = 1</p>
<p><i>PRINTER PARAMETERS</i></p>	}	<p>Wireless..... : OFF</p> <p>RS232 Baud Rate : 19200 bps</p> <p>RS232 Data Length : 8 bits/chr</p> <p>RS232 Parity : None</p> <p>RS232 Handshaking : Xon/Xoff</p> <p>Busy Condition : RxFull</p> <p>USB Address Number : 0</p> <p>USB Virtual COM..... : Disabled</p> <p>Autofeed : CR Disabled</p> <p>Print Mode : Normal</p> <p>Chars / inch : A=15 B=20 cpi</p> <p>Speed / Quality..... : Normal</p> <p>Notch Alignment : Enabled</p> <p>Notch Threshold : 40%</p> <p>Notch Distance [mm] : +15</p> <p>PaperEnd Buffer Clear : Disabled</p> <p>Font Type..... : International</p> <p>Code Table [num] : 00</p> <p>USB Virtual COM..... : Disabled</p> <p>Print Density : 0%</p>
<p><i>KEYS FUNCTIONS</i></p>	}	<p>[PUSH] enter Printer setup</p> <p>[FAST PUSH] skip setup</p>

Q3X (WiFi models)

<p><i>DEVICE NAME and FIRMWARE MODULES RELEASE</i></p>	}	<p style="text-align: center;">Q3X printer</p> <p>SCODE <code> - rel 2.22</p> <p>FCODE <code> - rel 1.00</p>
<p><i>DEVICE STATUS</i></p>	}	<p style="text-align: center;">PRINTER SETUP</p> <p>PRINTER TYPEQ3</p> <p>PRINTING HEAD TYPEKRB72</p> <p>INTERFACEUSB</p> <p>PROGRAM MEMORY TEST.....OK</p> <p>DYNAMIC RAM TEST.....OK</p> <p>EXTERNAL MEMORY TESTOK</p> <p>CUTTER TEST.....OK</p> <p>HEAD VOLTAGE [V] = 23.70</p> <p>HEAD TEMPERATURE [°C] = 25</p> <p>POWER ON COUNTER = 4</p> <p>PAPER PRINTED [cm] = 40</p> <p>CUT COUNTER = 1</p>
<p><i>WiFi MODULE PARAMETERS</i></p>	}	<p>[Network configuration]</p> <p>DHCP Client ⁽¹⁾.....: Disabled</p> <p>IP Address ⁽¹⁾.....: 192.168. 10. 52</p> <p>Subnet Mask ⁽¹⁾.....: 255.255.255. 0</p> <p>Default Gateway ⁽¹⁾.....: 192.168. 0. 5</p> <p>[Wi-Fi]</p> <p>WiFi SSID ⁽¹⁾.....: Custom</p> <p>Security Type ⁽¹⁾.....: NONE</p> <p>Wireless ⁽¹⁾.....: ON</p> <p>MAC Address WiFi ⁽¹⁾.....: 00-00-00-00-00-00</p>
<p><i>PRINTER PARAMETERS</i></p>	}	<p>Wireless.....: ON</p> <p>RS232 Baud Rate: 19200 bps</p> <p>RS232 Data Length.....: 8 bits/chr</p> <p>RS232 Parity.....: None</p> <p>RS232 Handshaking.....: Xon/Xoff</p> <p>Busy Condition.....: RxFull</p> <p>USB Address Number.....: 0</p> <p>USB Virtual COM.....: Disabled</p> <p>Autofeed.....: CR Disabled</p> <p>Print Mode.....: Normal</p> <p>Chars / inch.....: A=15 B=20 cpi</p> <p>Speed / Quality.....: Normal</p> <p>Notch Alignment.....: Enabled</p> <p>Notch Threshold.....: 40%</p> <p>Notch Distance [mm].....: +15</p> <p>PaperEnd Buffer Clear.....: Disabled</p> <p>Font Type.....: International</p> <p>Code Table [num].....: 00</p> <p>USB Virtual COM.....: Disabled</p> <p>Print Density.....: 0%</p>
<p><i>KEYS FUNCTIONS</i></p>	}	<p>[PUSH] enter Printer setup</p> <p>[FAST PUSH] skip setup</p>

NOTE:

(1) : To set the WiFi parameters of the device use the “CePrinterSet” tool, downloadable from the DOWNLOAD section of the web site www.custom.biz.

Q3X (Bluetooth® models)

*DEVICE NAME and
FIRMWARE MODULES
RELEASE*

Q3X printer	
SCODE <code>	- rel 2.22
FCODE <code>	- rel 1.00

PRINTER SETUP

*DEVICE
STATUS*

PRINTER TYPE Q3
PRINTING HEAD TYPE KRB72
INTERFACE BLUETOOTH
PROGRAM MEMORY TEST OK
DYNAMIC RAM TEST OK
EXTERNAL MEMORY TEST OK
CUTTER TEST OK
HEAD VOLTAGE [V] = 23.70
HEAD TEMPERATURE [°C] = 25
POWER ON COUNTER = 4
PAPER PRINTED [cm] = 40
CUT COUNTER = 1
BT PRINTER ID = Q3x_623065333430
PAIRING BT PIN = 1234
BT BUILD VERSION = 121016A IDPS

*PRINTER
PARAMETERS*

Wireless **ON**

BT AutoReconnect **Disabled**
Pairing BT **Disabled**
RS232 Baud Rate **19200 bps**
RS232 Data Length **8 bits/chr**
RS232 Parity **None**
RS232 Handshaking **Xon/Xoff**
Busy Condition **RxFull**
USB Address Number **0**
USB Virtual COM **Disabled**
Autofeed **CR Disabled**
Print Mode **Normal**
Chars / inch **A=15 B=20 cpi**
Speed / Quality **Normal**
Notch Alignment **Enabled**
Notch Threshold **40%**
Notch Distance [mm] **+15**
PaperEnd Buffer Clear **Disabled**
Font Type **International**
Code Table [num] **00**
USB Virtual COM **Disabled**
Print Density **0%**

KEYS FUNCTIONS

[**PUSH**] *enter Printer setup*
[**FAST PUSH**] *skip setup*

5.3 Device status

The device operating status is indicated in the configuration print-out in which, next to the name of the components displayed, the following information is given:

PRINTER TYPE	<i>device model</i>
PRINTING HEAD TYPE	<i>print head model</i>
INTERFACE	<i>interface present</i>
PROGRAM MEMORY TEST	<i>OK appears if functioning and NOT OK if faulty</i>
DYNAMIC RAM TEST	<i>OK appears if functioning and NOT OK if faulty</i>
EXTERNAL MEMORY TEST	<i>OK appears if functioning and NOT OK if faulty</i>
CUTTER TEST	<i>OK appears if functioning and NOT OK if faulty</i>
HEAD VOLTAGE	<i>voltage of the head</i>
HEAD TEMPERATURE	<i>temperature of the head</i>
POWER ON COUNTER	<i>number of power-ups made</i>
PAPER PRINTED	<i>centimetres of paper printed</i>
CUT COUNTER	<i>number of cuts performed</i>
BT PRINTER ID *	<i>printer identifier</i>
PAIRING BT PIN *	<i>printer password</i>
BT BUILD VERSION *	<i>firmware release of the Bluetooth® module</i>

NOTE:

* : Only for Bluetooth® models.

5.4 Printer parameters

This device allows the configuration of the parameters listed in the following table.

The parameters marked with the symbol ^D are the default values.

Settings remain active even after the device has been turned off and they are stored in non-volatile memory.

Wireless

Activation of the Bluetooth® module or WiFi on the device:

ON
OFF ^D

NOTE: If the "Wireless" parameter is set to ON (active) do not connect any communication cable to the device. Otherwise disconnect all communication cables from the device to work with the Wireless mode.

BT AutoReconnect

Setting the automatically connection function (only for Apple® devices)

Disabled ^D = AutoReconnect function disabled. To communicate with the printer must perform the pairing between the Apple® device and the printer when communication is interrupted (power off, stand by, etc.).

Enabled = AutoReconnect function enabled. The printer automatically attempts to restore the connection with the last device connected Apple® whenever communication is interrupted (power off, stand by, etc.). Before enabling this function, you must perform the pairing between the Apple® device and printer.

NOTE: The parameter is printed only for Bluetooth® models.

Pairing BT

Setting the pairing function for the Bluetooth® devices:

Disabled ^D = pairing function disabled. No passkey is requested to make association

Enabled = pairing function enabled. To set it entering the pincode/passkey indicated on the setup report "Pairing BT PIN" (1234).

NOTE: The parameter is printed only for Bluetooth® models.
To communicate with Bluetooth® devices Apple® set the parameter to Disabled.

RS232 BAUD RATE

Communication speed of the serial interface:

1200 19200 ^D
2400 38400
4800 57600
9600 115200

NOTE: Parameter valid only with serial interface.

RS232 DATA LENGTH

Number of bit used for characters encoding:

7 bits/char
8 bits/char ^D

NOTE: Parameter valid only with serial interface.

RS232 PARITY

Bit for the parity control of the serial interface:

*None^D = parity bit omitted
Even = even value for parity bit
Odd = odd value for parity bit*

NOTE: Parameter valid only with serial interface.

RS232 HANDSHAKING

Handshaking:

*XON/XOFF^D = software handshaking
Hardware = hardware handshaking (CTS/RTS)*

NOTE:
Parameter valid only with serial interface.

When the receive buffer is full, if handshaking is set to XON/XOFF, the device sends the XOFF (0x13) on the serial port. When the receive buffer has cleared once again, if handshaking is set to XON/XOFF, the device sends the XON (0x11) on the serial port.

BUSY CONDITION

Activation mode for Busy signal:

*OffLine/ RXFull = Busy signal is activated when the device is both in OffLine status and the buffer is full
RXFull^D = Busy signal is activated when the buffer is full*

NOTE: Parameter valid only with serial interface.

USB ADDRESS NUMBER

Numerical address code for the univocal identification of the USB device (in case of more than a USB device connected with the same PC):

<i>0^D</i>	<i>2</i>	<i>4</i>	<i>6</i>	<i>8</i>
<i>1</i>	<i>3</i>	<i>5</i>	<i>7</i>	<i>9</i>

AUTOFEED

Setting of the Carriage Return character:

*CR disabled^D = Carriage Return disabled
CR enabled = Carriage Return enabled*

PRINT MODE

Printing mode:

*Normal^D = enables printing in normal writing way
Reverse = enables printing rotated 180 degrees*

CHARS / INCH

Font selection:

*A = 11 cpi, B = 15 cpi
A = 15 cpi, B = 20 cpi^D*

NOTE: CPI = Characters Per Inch

SPEED / QUALITY

Setting of printing speed and printing quality:

*Normal^D
High Quality*

NOTCH ALIGNMENT*Alignment management:**Disabled^D = the notch alignment is not performed**Enabled = the notch alignment is performed*

NOTCH THRESHOLD*Threshold value (in percent) for the recognition of the presence of notch by the notch sensor:*

0.75V	1.50V	2.25V
1.00V	1.75V ^D	2.50V
1.25V	2.00V	2.75V

NOTE: If the "Notch Alignment" parameter is disabled, this parameter is not printed.

NOTCH DISTANCE*"Notch Distance" is the minimum distance (in mm) between the upper edge of ticket and the notch (see chapter 10).**The numeric value of the distance is made up with the following four parameters for the setting of three digits (two for the integer part of the number, one for the decimal part and of the sign):*

*Setting the digit for tens:***NOTCH DISTANCE [mm x 10]**

0 ^D	2	4	6	8
1	3	5	7	9

*Setting the digit for units:***NOTCH DISTANCE [mm x 1]**

0 ^D	2	4	6	8
1	3	5	7	9

*Setting the digit for decimals:***NOTCH DISTANCE [mm x .1]**

0 ^D	2	4	6	8
1	3	5	7	9

NOTES:*For example, to set the notch distance to 15 mm, modify the parameters as follows:**Notch Distance [mm x 10] = 1**Notch Distance [mm x 1] = 5**Notch Distance [mm x .1] = 0**If the "Notch Alignment" parameter is disabled, the parameters for the "Notch Distance" are not printed.*

PAPEREND BUFFER CLEAR*Cleaning mode of the data in receive buffer, if the printing is stopped due to lack of paper:**Disabled^D = The data remain in the receive buffer. When the paper runs out, the device keeps the remaining data in the receive buffer and prints the remaining portion of the ticket after that the new paper is loaded.**Enabled = When the paper runs out, all data in the receive buffer are deleted.*

FONT TYPE

Setting of the font type:

International^D = Enables the use of the 256 characters font tables

Chinese GB18030 = Enables the use of the chinese extended font GB18030-2000

NOTE: When the "INTERNATIONAL" font is enabled, you need to choose the character code table (parameter "CODE TABLE"). When the Chinese or Korean fonts is enabled, the selection of the character code table is suspended (parameter "CODE TABLE").

CODE TABLE [num]

Identifier number of the character code table to use.

The numeric value of the identifier is made up with the following two parameters for the setting of two digits for the tens and the units:

Setting the digit for tens:

CODE TABLE [num x 10]

<i>0^D</i>	<i>2</i>	<i>4</i>
<i>1</i>	<i>3</i>	<i>5</i>

Setting the digit for units:

CODE TABLE [num x 1]

<i>0^D</i>	<i>2</i>	<i>4</i>	<i>6</i>	<i>8</i>
<i>1</i>	<i>3</i>	<i>5</i>	<i>7</i>	<i>9</i>

NOTE:

See the paragraph 7.7 to learn about the character tables corresponding to the identification numbers set with this parameter.

The character tables set with this parameter are the same set with the command 0x1B 0x74 (refer to the Commands Manual of the device).

USB VIRTUAL COM

Setting the USB port as a virtual serial port:

Disabled^D = Virtual COM disabled

Enabled = Virtual COM enabled

NOTE: To use this configuration it is necessary to install an additional driver.

PRINT DENSITY

Adjusting the printing density:

<i>--25%</i>	<i>0%^D</i>	<i>+25%</i>
<i>-12%</i>	<i>+12%</i>	

5.5 Hexadecimal dump

This function is used for the diagnosis of the characters received from the communications port. Characters are printed as hexadecimal code and the corresponding ASCII code (see below). Each line is preceded by a counter in hexadecimal that indicates the number of bytes received.

During the startup, if you hold down the FEED key, the printer enters the self-test routine and print the setup report. The printer remains in standby until a key is pressed or characters are received through the communication port (Hexadecimal Dump mode). For each character sent, the receipt contain an indication of the hexadecimal and ASCII values (if the characters are underlined, the receive buffer is full). Shown below is an example of a Hexadecimal Dump:

HEXADECIMAL DUMP									
31	32	33	34	35	...	<u>12345</u>	...		
39	30	31	32	33	...	<u>90123</u>	...		
37	38	39	75	69	...	<u>789ui</u>	...		
68	6B	6A	73	64	...	<u>hkjsd</u>	...		
73	64	66	6B	6A	...	<u>sdfkj</u>	...		
66	73	64	66	6B	...	<u>fsdfk</u>	...		
65	69	6F	79	75	...	<u>eioyu</u>	...		
6F	72	69	75	77	...	<u>oriuw</u>	...		
6F	75	77	65	72	...	<u>ouwer</u>	...		
77	65	72	69	6F	...	<u>werio</u>	...		
72	69	6F	75	77	...	<u>riouw</u>	...		
6B	6C	73	64	66	...	<u>kl sdf</u>	...		
64	66	6B	73	64	...	<u>dfksd</u>	...		
73	64	66	6B	6A	...	<u>sdfkj</u>	...		
66	6B	F2	6A	73	...	<u>fk>j</u>	...		
6A	6B	6C	68			<u>jklh</u>			

6 MAINTENANCE

6.1 Paper jam

1

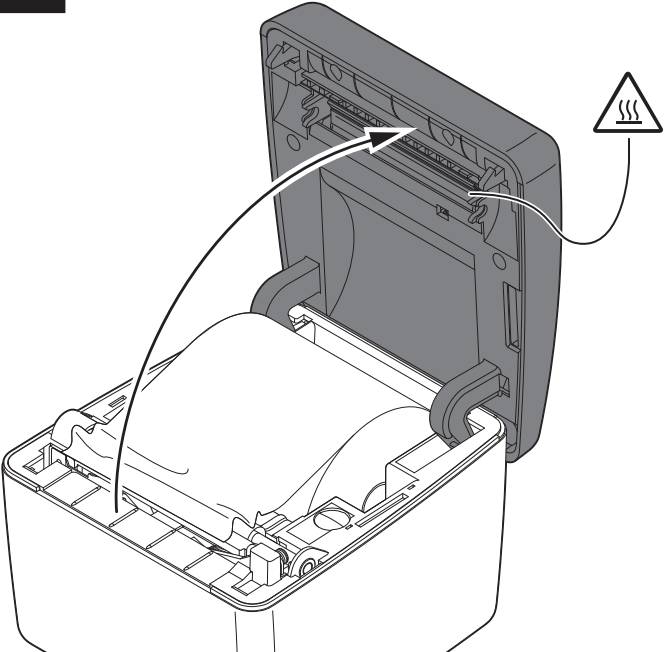

Open the device cover
(see par. 4.2).

2

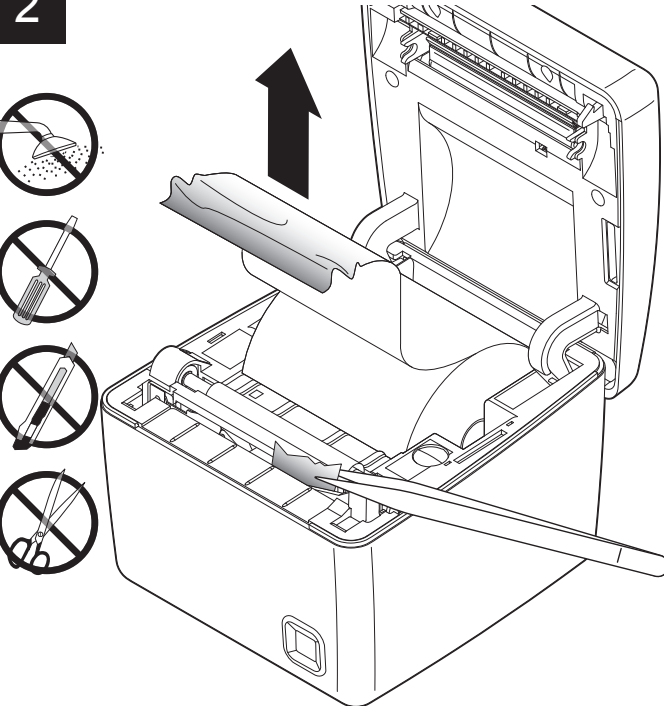

Lift the damage paper,
check and remove possible scraps of paper
along the cutter path.

3

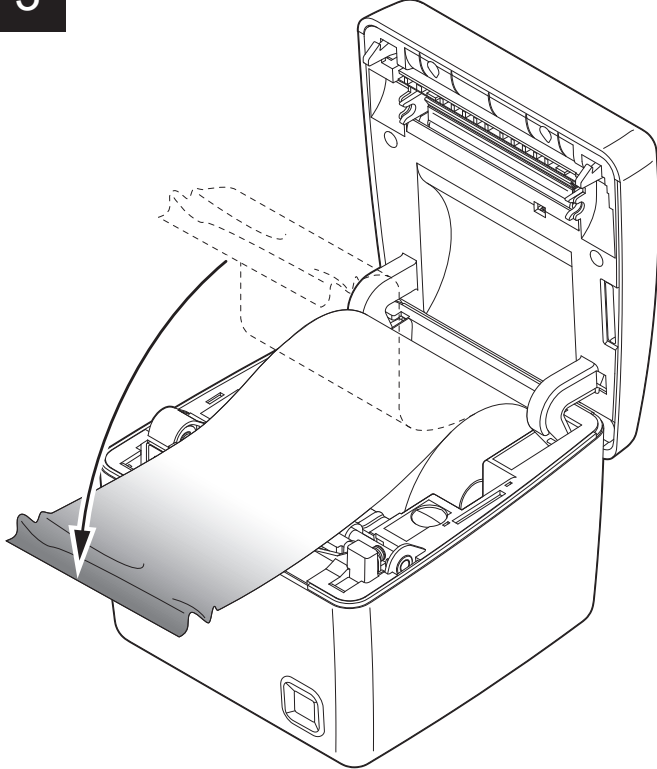

Pull the paper in order to have the damaged part
outside the device.

4

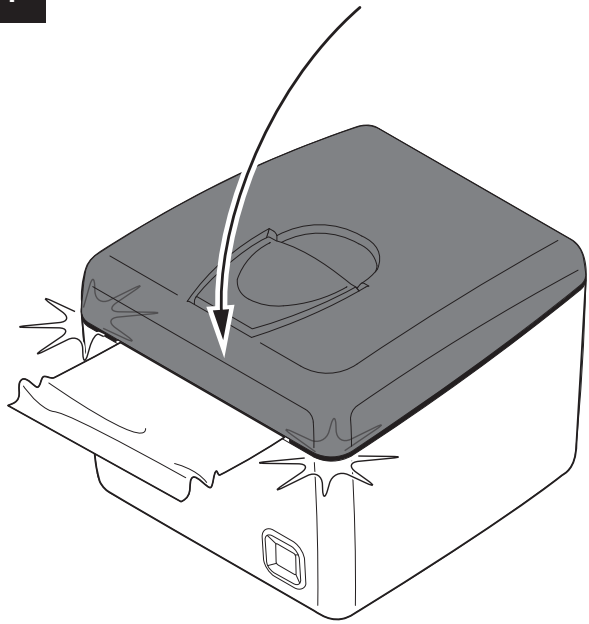

Close the cover.

6.2 Planning of cleaning operations

The regular cleaning of the device keeps the print quality and extends its life. The following table shows the recommended planning for the cleaning operations.

EVERY PAPER CHANGE	
Printhead	Use isopropyl alcohol
Rollers	Use isopropyl alcohol
EVERY 5 PAPER CHANGES	
Cutter	Use compressed air
Paper path	Use compressed air or tweezers
Sensors	Use compressed air
EVERY 6 MONTHS OR AS NEEDED	
Printer case	Use compressed air or a soft cloth

For specific procedures, see the following pages.

NOTE:

If you use the device in dusty environments, you must reduce the intervals between the cleaning operations.

6.3 Cleaning

For periodic cleaning of the device, see the instructions below

Sensors

1

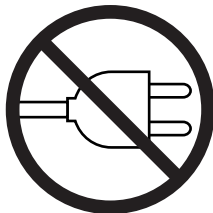

Disconnect the power supply cable and open the device cover (see par. 4.2)

2

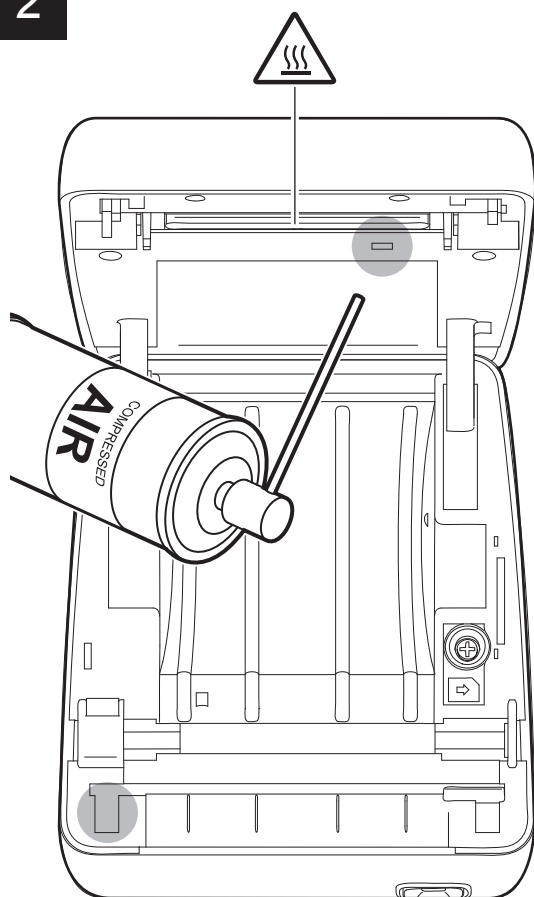

ATTENTION:

Do not use alcohol, solvents, or hard brushes.
Do not let water or other liquids get inside the device.



Clean the device sensors
by using compressed air.

Paper path

1

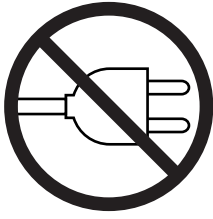

Disconnect the power supply cable and open the device cover (see par. 4.2)

2

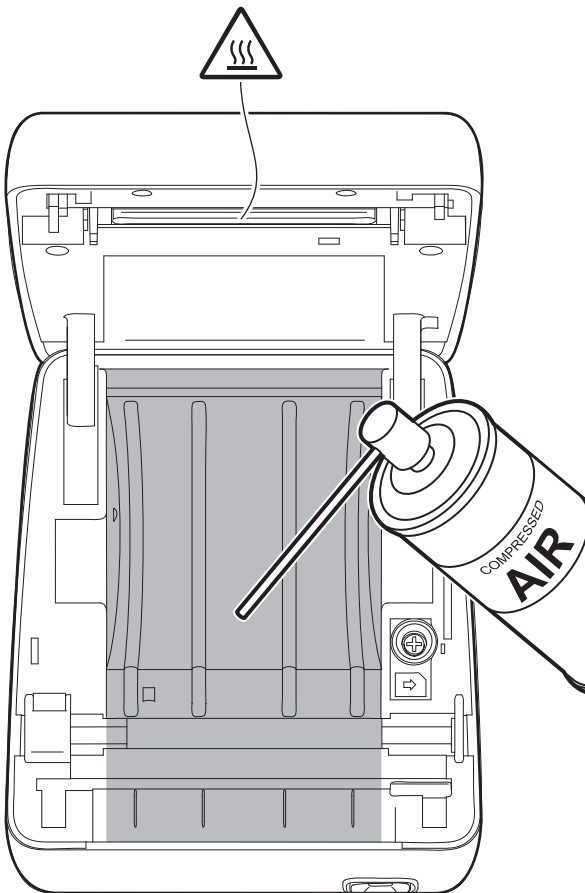

ATTENTION:

Do not use alcohol, solvents, or hard brushes.
Do not let water or other liquids get inside the device.



Clean the area involved in the passage of paper by using compressed air.

Print head

1

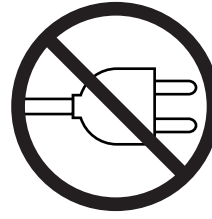

Disconnect the power supply cable and open the device cover (see par. 4.2)

2

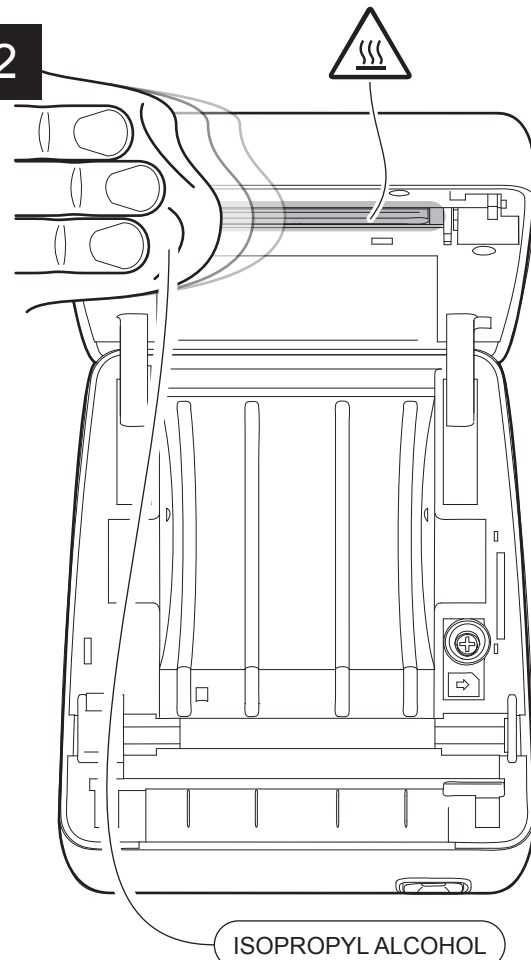

ATTENTION:

Do not use solvents, or hard brushes.
Do not let water or other liquids get inside the device.



Clean the printing head by using a non-abrasive cloth moistened with isopropyl.

Printing roller

1

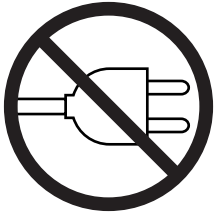

Disconnect the power supply cable and open the device cover (see par. 4.2)

2

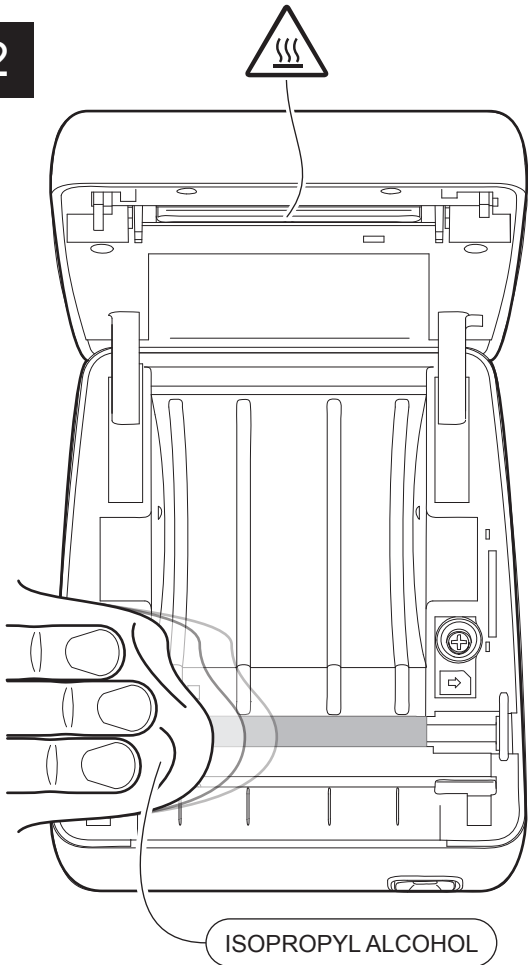

ATTENTION:
Do not use solvents, or hard brushes.
Do not let water or other liquids get inside the device.



Clean the printing roller by using a non-abrasive cloth moistened with isopropyl.

Case

1

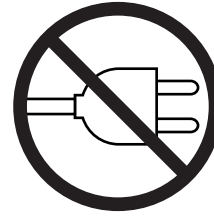

Disconnect the power supply cable

2

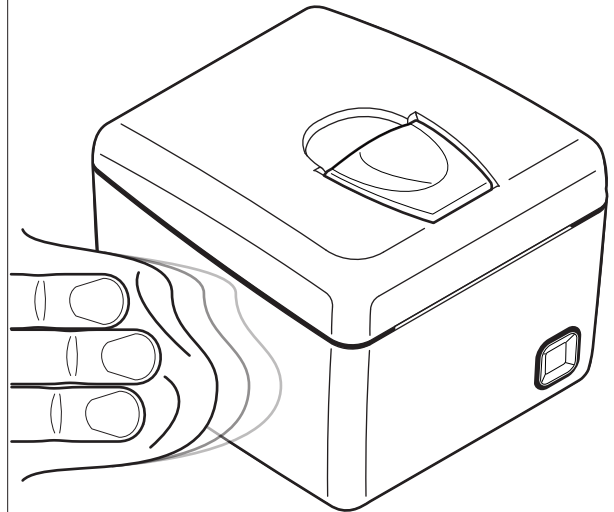

ATTENTION:
Do not use alcohol, solvents, or hard brushes.
Do not let water or other liquids get inside the device.



To clean the device, use compressed air or a soft cloth.

Cutter

1

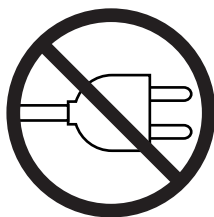

Disconnect the power supply cable and open the device cover (see par. 4.2)

2

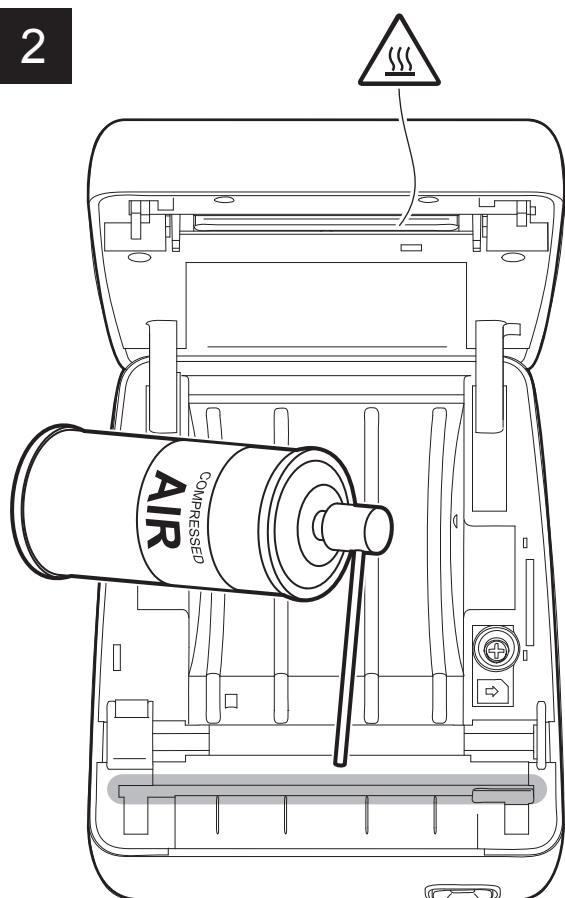

ATTENTION:

Do not use alcohol, solvents, or hard brushes.
Do not let water or other liquids get inside the device.



Clean the cutter compartment from the inside using compressed air.

6.4 Upgrade firmware

WARNING: During communication between PC/device for the firmware update it is strictly forbidden to disconnect the communication cable or to remove the power supply of the devices not to endanger the proper functioning of the device.

NOTES:

The latest firmware of the device is available in the download area of the web site www.custom.biz

Install on the PC used for device upgrading the UPG-CEPRN software available in the download area of the web site www.custom.biz.

UPDATE VIA SERIAL INTERFACE

Proceed as follows:

1. Write down the product code (14 digits) printed on the product label (see par. 2.3).
2. Go to the web site www.custom.biz and download the appropriate firmware release from the DOWNLOAD area.
3. Print the SETUP report (see chapter 5).
4. Switch OFF the device.
5. Connect the device to the PC using a serial cable (see paragraph 3.2).
6. Switch ON the device.
7. Launch the software UPGCEPRN.
8. Select the update file .PSW location:

9. Select the serial communication port (ex. COM1):

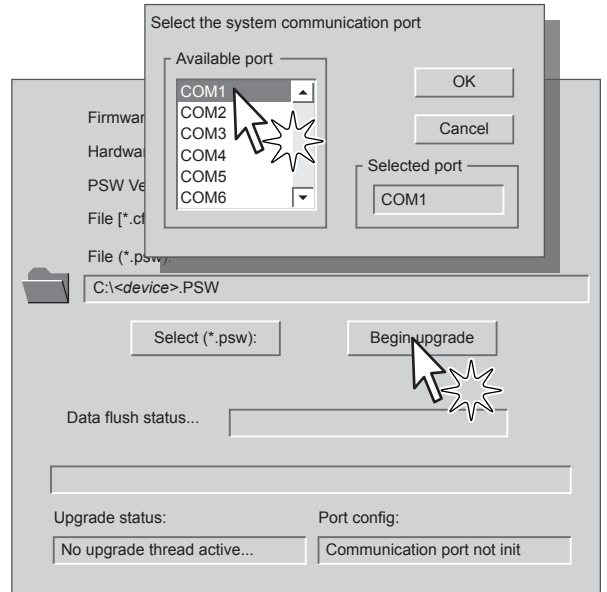

10. Detecting and setting of the parameters necessary for serial communication are performed automatically and then updating begins.
11. After a few minutes a message on the screen warns that the update is completed.

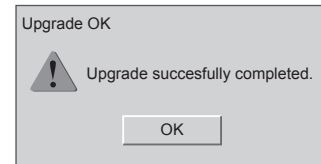

12. Print a new SETUP report to verify the new firmware release (see chapter 5).

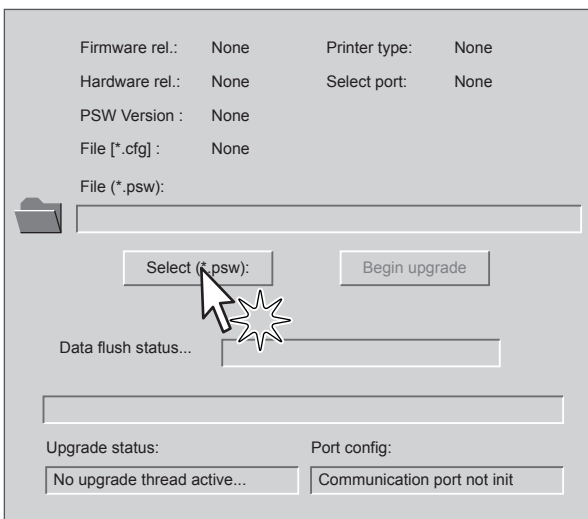

UPDATE VIA USB INTERFACE

ATTENTION:

Only during the firmware update, the connection between PC and device must be direct, without the use of wireless HUB.

Only during the firmware update, do not connect or disconnect other USB devices.

NOTE: For communication via USB you must install on PC the device driver available in the download area of the web site www.custom.biz.

Proceed as follows:

1. Write down the product code (14 digits) printed on the product label (see par. 2.3).
2. Go to the web site www.custom.biz and download the appropriate firmware release from the DOWNLOAD area.
3. Print the SETUP report (see chapter 5).
4. Switch OFF the device.
5. Connect the device to the PC using a USB cable (see paragraph 3.2).
6. Switch ON the device.
7. Launch the software UPGCEPRN.
8. Select the update file .PSW location:

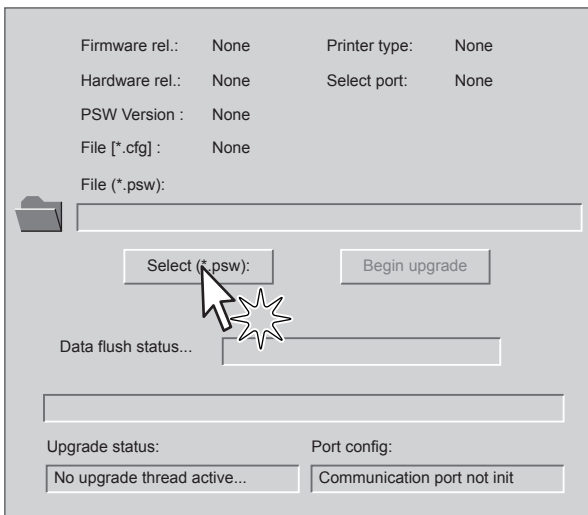

9. Select item USB and then select the USB device among those proposed (e.g. device1):

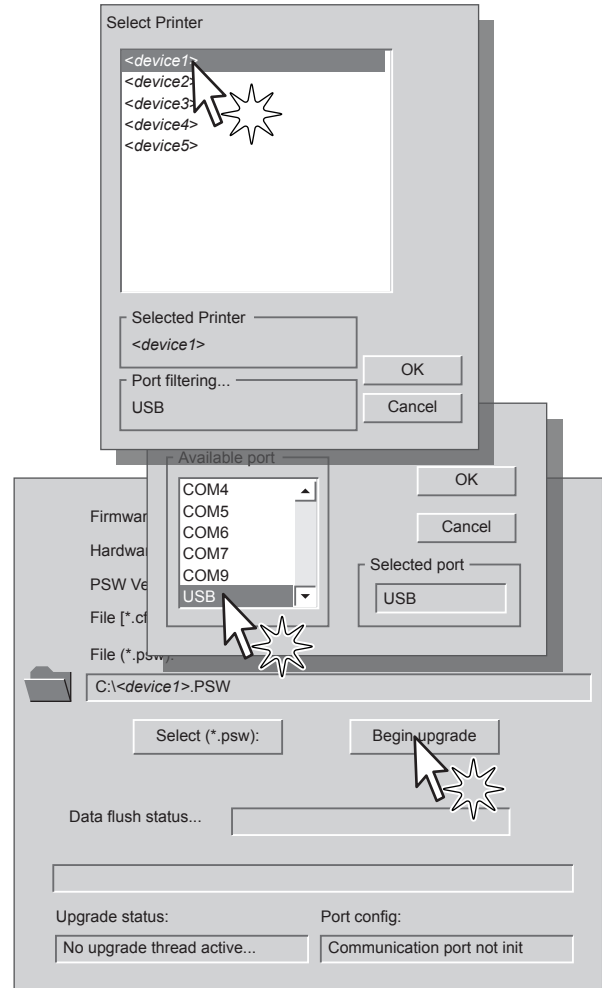

10. After a few minutes a message on the screen warns that the update is completed.

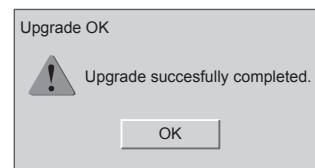

11. Print a new SETUP report to verify the new firmware release (see chapter 5).

7 SPECIFICATION

7.1 Hardware specifications

GENERALS	
Sensors	Head temperature, paper presence, detection of black mark, cover open
MTBF ⁽¹⁾	127 243 hours
Emulations	CUSTOM/POS
Printing driver	Windows XP, VISTA (32/64bit), Windows 7 (32/64bit), Windows 8 (32/64bit), Windows 8.1 (32/64bit), OPOS, Linux (32/64bit), Android iOS
INTERFACES	
USB port	12 Mbit/sec (USB 2.0 full speed)
RS232 serial port	from 1200 to 115200 bps
MEMORIES	
Receive buffer	20 Kbytes
Flash memory	4 Mbytes (+1Mbyte internal to the micro)
RAM memory	2 Mbytes
Graphic memory	1 logo (576 x 910 dots)
PRINTER	
Resolution	203 dpi (8 dot/mm)
Printing method	Thermal, fixed head
Head life ⁽²⁾	50 Km / 100M pulse
Printing width	72 mm

Printing mode	Normal, 90°, 180°, 270°
Printing format	Height/Width from 1 to 8, bold, reverse, underlined, italic
Character fonts	54 character code tables (see par. 7.7) Extended chinese GB18030-2000
Printable barcode	UPCA, UPCE, EAN13, EAN8, CODE39, ITF, CODABAR, CODE93, CODE128, CODE32, PDF417
Printing speed ⁽²⁾ ⁽³⁾	Normal = 140 mm/sec High Quality = 100 mm/sec

PAPER

Type of paper	Thermal rolls, heat-sensitive side on outside of roll
Paper width	80 mm ± 0,5 mm
Paper weight	from 55 g/m ² to 60 g/m ²
Paper thickness	63 µm
Recommended types of paper	KANZAN KF50 MITSUBISHI PF5067
External roll diameter	max. 80 mm
Internal roll core diameter	12 mm (+ 1mm) 25 mm (+ 1mm)
Core thickness	2 mm (+1 mm)
Paper end	Not attached to roll core
Core type	Cardboard or plastic

CUTTER

Paper cut	Partial
Estimated life ⁽²⁾	1 000 000 cuts

WI-FI MODULE SPECIFICATIONS

Standards	IEEE 802.11b/g
-----------	----------------

Wireless speed	11 Mbps
Protocol supported	TCP/IP, IPv4
Security	40 bits and 128 bits WPA and WPA2 encryption
Antenna	2.4-GHz chip antenna
Power supply	DC 3.3V

BLUETOOTH® MODULE SPECIFICATIONS

Communication speed	Bluetooth® = 2.0 Class 2 - SPP (Serial port profile)
---------------------	--

PRINTER ELECTRICAL SPECIFICATIONS

Power supply	24 Vdc ±10% (optional external power supply)
Medium consumption ⁽³⁾	1 A
Stand-by consumption	0.05 A

ELECTRICAL SPECIFICATIONS POWER SUPPLY cod.961GE020000001 ⁽⁴⁾

Power supply voltage	from 100 Vac to 240 Vac
Frequency	from 47 Hz to 63 Hz
Current (output)	2.5 A
Power	60 W

ELECTRICAL SPECIFICATIONS POWER SUPPLY cod.963GE020000003 (optional)

Power supply voltage	from 100 Vac to 240 Vac
Frequency	from 50 Hz to 60 Hz
Current (output)	2.5 A
Power	60 W

ENVIRONMENTAL CONDITIONS

Operating temperature	from 0°C to +50°C
Relative humidity	from 10% Rh to 85% Rh

Storage temperature from -20 °C to +70 °C

Storage relative humidity from 10% Rh to 90% Rh

NOTES:

(1) : Control board

(2) : Respecting the regular schedule of cleaning for the device components.

(3) : Referred to a standard CUSTOM receipt (L=10cm, Density = 12,5% dots on).

(4) : For receipts with wide black zones is recommended the optional power supply cod. 963GE020000003 that provides a peak current higher for larger time intervals.

7.2 Character specifications

Character set		3	
Character density	11 cpi	15 cpi	20 cpi
Number of columns	32	42	56
Chars / sec	1815	2310	3080
Lines / sec	55	55	55
Characters (L x H mm)-Normal	2.25 x 3	1.75 x 3	1.25 x 3

NOTE: Theoretical values.

7.3 Device dimensions

Length	140 mm
Height	117 mm
Width	150 mm
Weight	920 g

NOTES:

Dimensions referred to devices without paper roll.

All the dimensions shown in following figures are in millimetres.

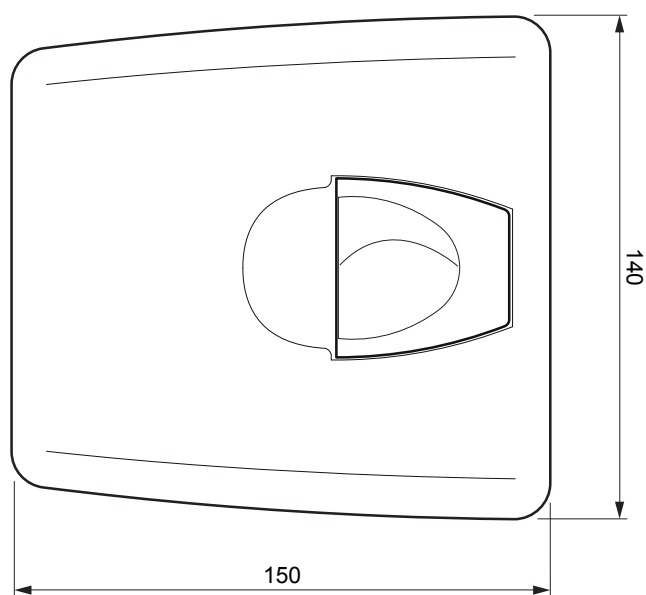
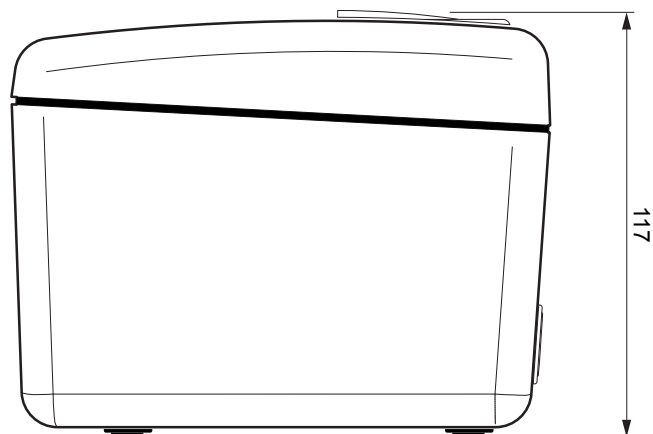
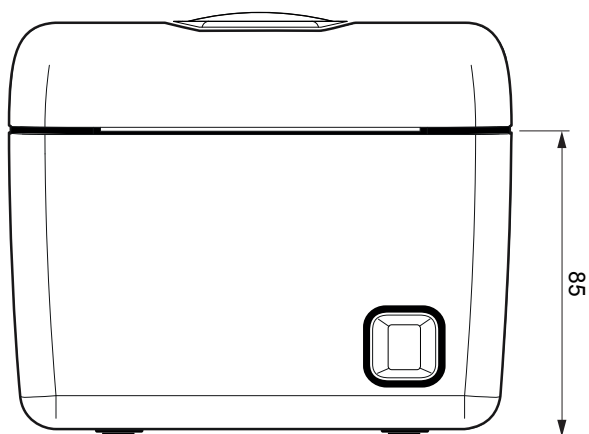

7.4 Power supply dimensions cod. 961GE020000001

Length	112 mm
Height	27 mm
Width	48 mm

All the dimensions shown in following figures are in millimetres.

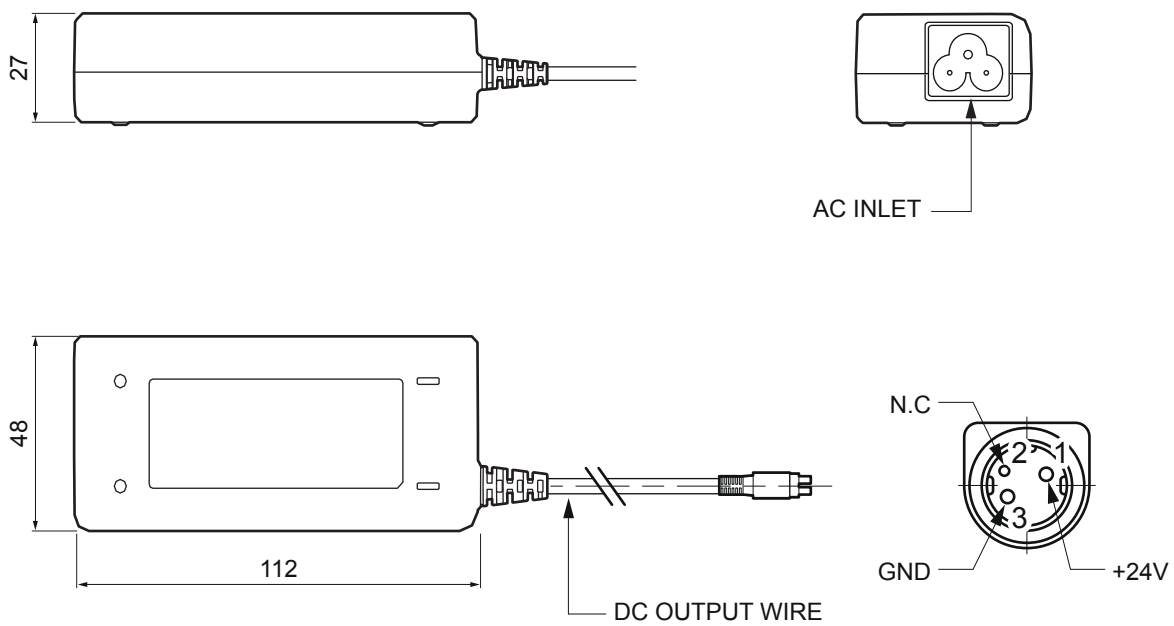

7.5 Power supply dimensions cod. 963GE02000003 (optional)

Length	127 mm
Height	35.5 mm
Width	56 mm

All the dimensions shown in following figures are in millimetres.

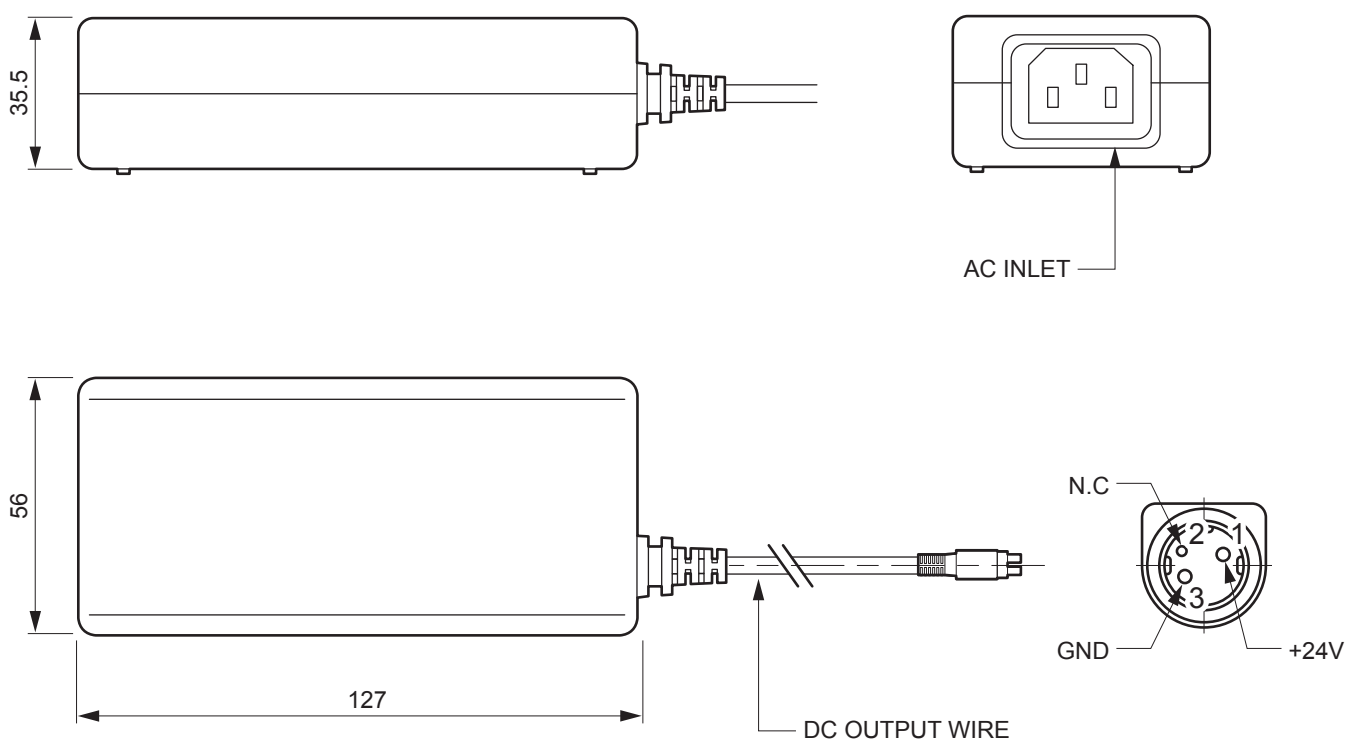

7.6 Paper specification

Paper with black mark for fixed sensor

The following image shows the placement of the black mark on the thermal side of the paper. For more information about the use of paper with black mark see Chapter 10.

All the dimensions shown in following figures are in millimetres.

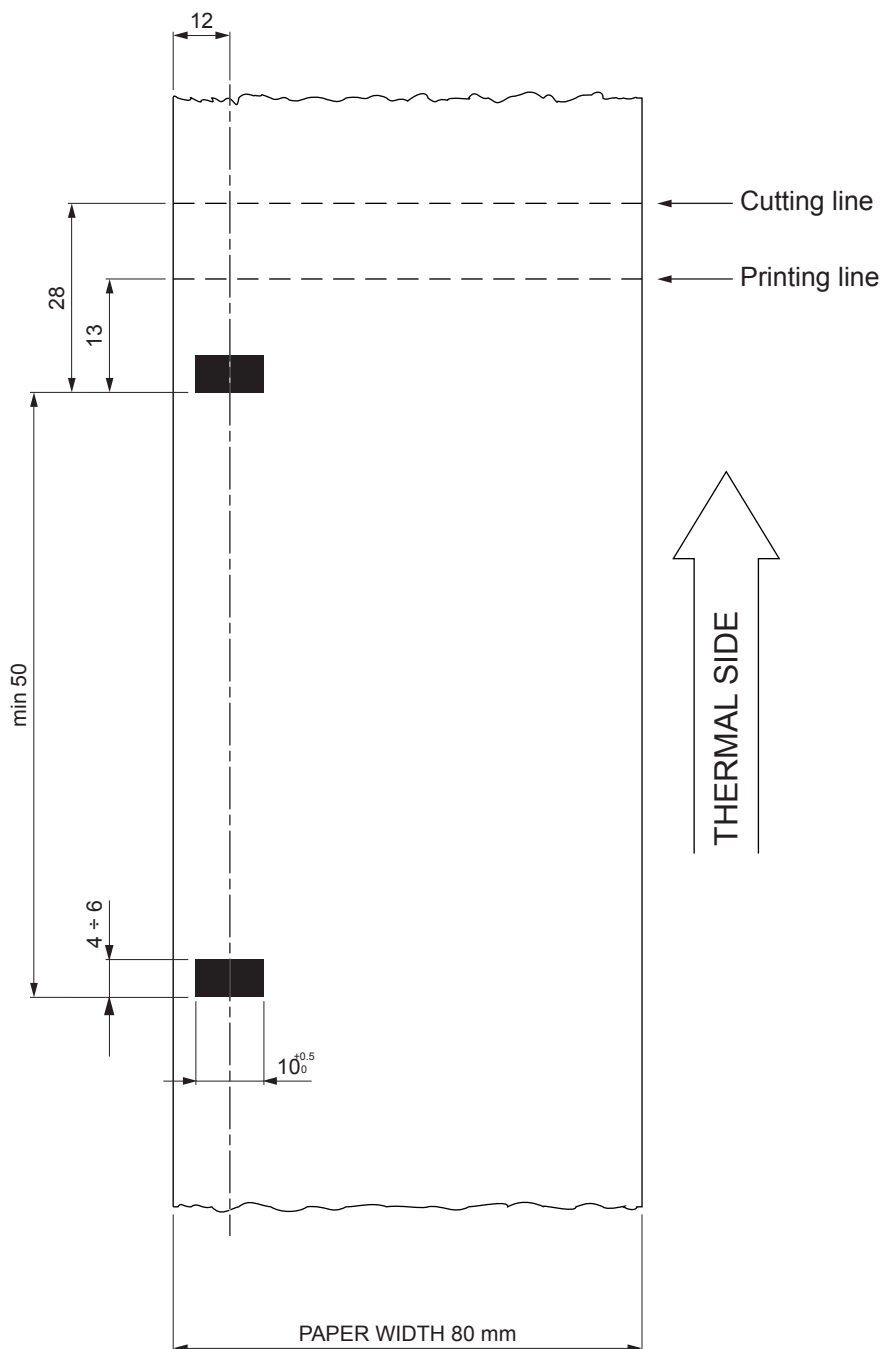

7.7 Character sets in CUSTOM/POS emulation

The printer has 3 internal fonts with a width of 11, 15, 20 cpi, which can be associated with one of the coding tables stored on the device.

The selection of the font and the encoding table is done via command (see the commands manual of the device) or through the Setup procedure by properly setting the parameter “Chars / Inch”, “Code Table” (see par. 5.4).

The following is the complete list of coding tables that can be installed on the device.

<CodeTable>	Character Tables	
0	PC437 - U.S.A., Standard Europe	
1	Katakana	
2	PC850 - Multilingual	
3	PC860 - Portuguese	
4	PC863 - Canadian/French	
5	PC865 - Nordic	
11	PC851 - Greek	on request
12	PC853 - Turkish	on request
13	PC857 - Turkish	From Release 4.1 and subsequent
14	PC737 - Greek	
15	ISO8859-7 - Greek	on request
16	WPC1252	on request
17	PC866 - Cyrillic 2	
18	PC852 - Latin 2	
19	PC858 for Euro symbol at position 213	
20	KU42 - Thai	
21	TIS11 - Thai	on request
26	TIS18 - Thai	on request
30	TCVN_3 - Vientamese	on request
31	TCVN_3 - Vientamese	on request
32	PC720 - Arabic	on request
33	WPC775 - Baltic Rim	on request
34	PC855 - Cyrillic	

<CodeTable>	Character Tables	
35	PC861 - Icelandic	on request
36	PC862 - Hebrew	
37	PC864 - Arabic	
38	PC869 - Greek	on request
39	ISO8859-2 - Latin 2	on request
40	ISO8859-15 - Latin 9	on request
41	PC1098 - Farci	on request
42	PC1118 - Lithuanian	on request
43	PC1119 - Lithuanian	on request
44	PC1125 - Ukranian	on request
45	WPC1250 - Latin 2	
46	WPC1251 - Cyrillic	on request
47	WPC1253 - Greek	on request
48	WPC1254 - Turkish	on request
49	WPC1255 - Hebrew	on request
50	WPC1256 - Arabic	on request
51	WPC1257 - Baltic Rim	on request
52	WPC1258 - Vientamese	on request
53	KZ1048 - Kazakhstan	on request
255	Space page	



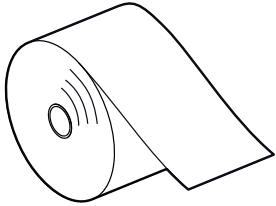

8 CONSUMABLES

The following table shows the list of available consumables for device:

DESCRIPTION	CODE
<p>THERMAL PAPER ROLL</p> <p>weight = 58g/m² width = 80mm Ø external = 80mm Ø core = 12mm</p>	<p>67300000000398</p> 

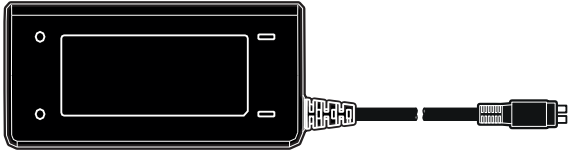
9 ACCESSORIES

The following table shows the list of available accessories for device:

DESCRIPTION	CODE
<p>POWER SUPPLY (for technical specifications, see the paragraph 7.1)</p>	<p>961GE02000001</p> 
<p>POWER SUPPLY (for technical specifications, see the paragraph 7.1)</p>	<p>963GE02000003</p> 
<p>SERIAL CABLE 9 pin male connector - 9 pin female connector 1.8 mt</p>	<p>2650000000352</p> 
<p>USB CABLE AB type 1.8 mt</p>	<p>2650000000356</p> 

10 ALIGNMENT

Device is provided with a sensor for the use of alignment notch in order to handle roll of tickets with pre-printed fields and a fixed length;

The alignment notch may be formed by black mark printed on paper (see par.7.6).

The alignment sensor assembled on the device is “reflection” sensor: this kind of sensor emits a band of light and detects the quantity of light reflected to it. The presence of the notch is therefore detected by the amount of light that returns to the sensor, considering that the light is reflected by the white paper and absorbed by the black mark.

The following paragraphs show how to correctly set the configuration parameters of device in order to assure the alignment.

10.1 Enable alignment

Device is provided with one sensor for alignment, placed on the upper flat of device.

To guarantee the alignment, it is necessary to correctly choose the sensor to use for the notch detection depending on the type of notch and its location on the ticket.

To do this, you must enable the parameter “Notch Alignment” during the Setup procedure (see chapter 5) and set the correct value of this parameter as described in the following table.

SENSOR USED (see following figures)	VALUE OF THE “NOTCH ALIGNMENT” PARAMETER	USING MODE OF SENSOR	NOTCH TYPE
-	Disabled	-	Alignment disabled
1	Enabled	Reflection	Black mark printed on the thermal side of paper

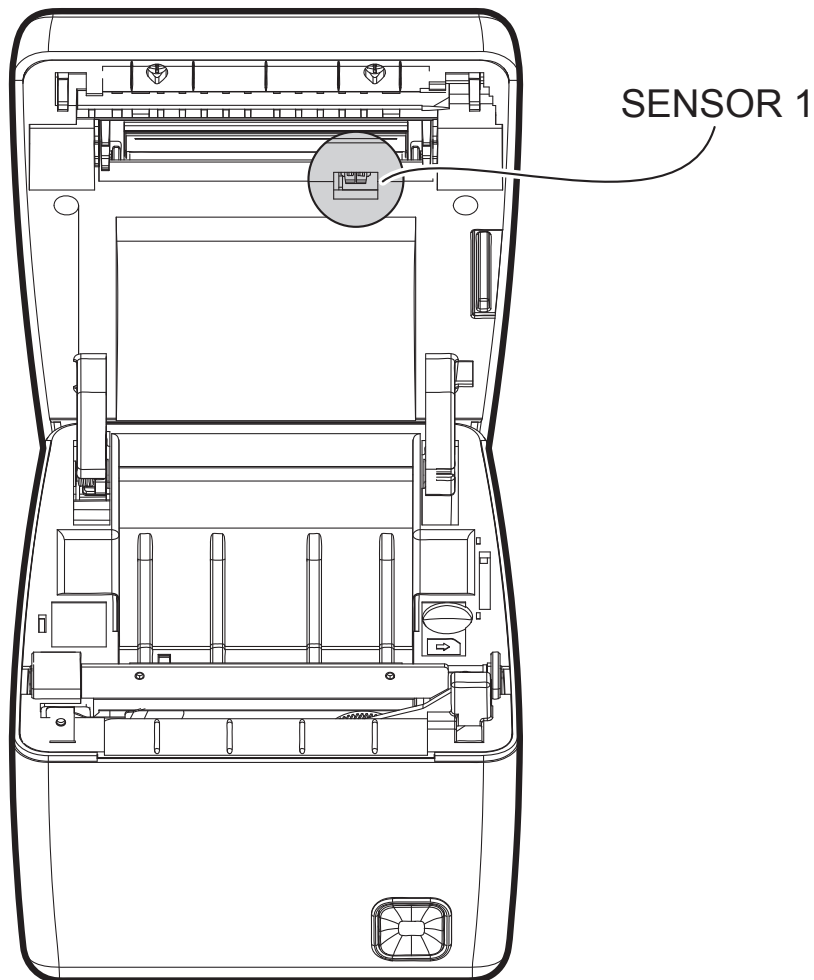

The following figure show the usable format of paper and the corresponding sensor used for alignment:

Paper with black mark on the thermal side

In the standard model the detection of black mark and paper presence is performed by the fixed sensor.

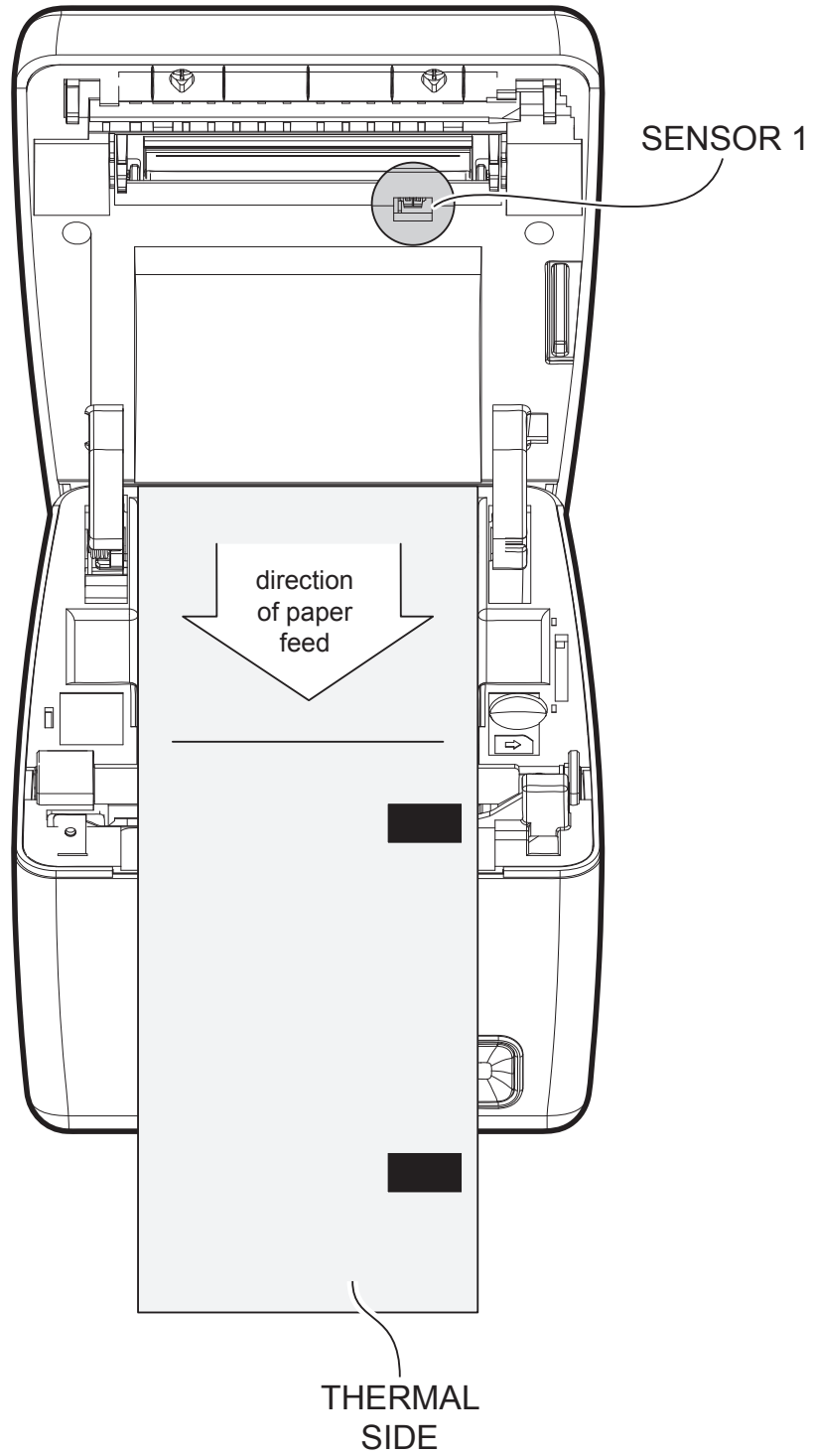

10.2 Calibration

The sensor calibration occurs automatically and consists in adjusting the quantity of light emitted to match the degree of whiteness of the paper used and the degree of black of the mark printed on paper.

The device automatically performs the self-calibration during the Setup procedure only if the “Notch Alignment” parameter is set to a value other than “Disabled” (see chapter 5).

When self-calibration starts, the device performs some paper feeds and then it prints the calibration result and the value of the PWM duty-cycle of the alignment sensor driver so that it can be perform an optimal notch detection:

Autosetting Notch : OK
Polarization Volt : 2.4V [75%]

The “Autosetting Notch” parameter indicates the result of the self-calibration procedure; OK will appear if it has been successful, NOT OK will appear if the procedure has failed.

After the printing of the procedure result, the device offers the execution of the function of paper characterization “Characterize Paper” and the change of the “Notch Threshold” parameter which represents the detection threshold of the notch. Choosing the “Yes” value for the “Characterize Paper” parameter, the device prints a graphic representation (see following figures) of the outgoing voltage of the alignment sensor (expressed as a percentage) and the “Notch Threshold” value. This graphic representation is useful to set the most suitable value to assign to the “Notch Threshold” parameter and then to better identify the optimal threshold value which takes into account the variations of the signal and the small oscillations around zero.

The following figure shows an example of paper with the non-thermal paper printed with black marks: the outgoing voltage is constant while passing the white paper between two notches and presents a peak at each black mark. In this case, the optimal value for the “Notch Threshold” parameter is placed about half of the peak.

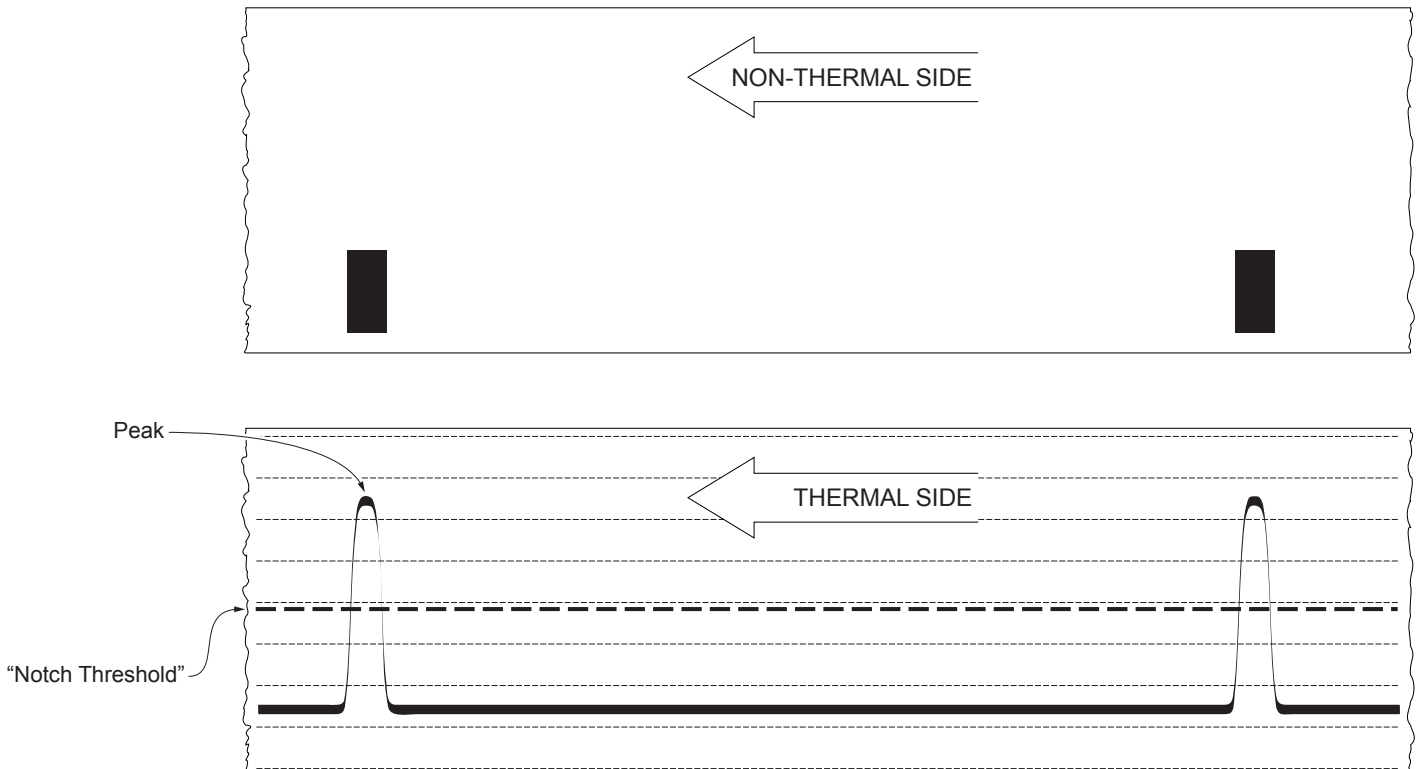

The following figure shows an example of paper with the non-thermal paper printed with black marks and other graphics (for example, a barcode): the outgoing voltage is constant while passing the white paper between two notches, presents a peak at each black mark and presents some “noise” at each barcode. In this case, the optimal value for the “Notch Threshold” parameter is located about halfway between the peak value and the maximum value of the “noise”.

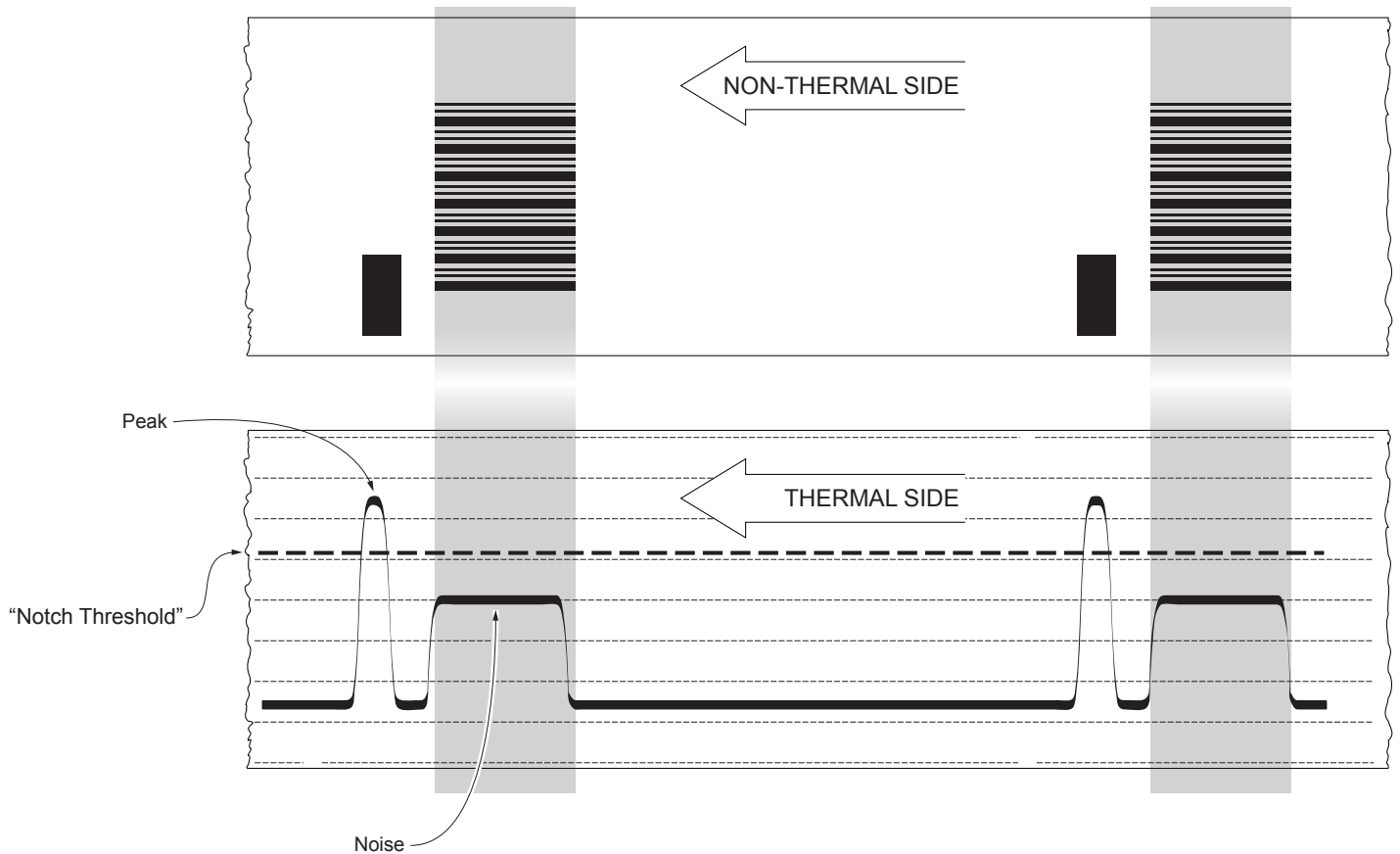

If the maximum value of “noise” read by the sensor is very close to the peak value, it might be difficult to place the value of the “Notch Threshold” at an intermediate point. In these cases, it is mandatory that the portion of paper between the point of printing end and the front notch is completely white (no graphics). In this way, the only next graphic detected by the sensor for alignment after the printing end will be the notch.

10.3 Alignment parameters

The “alignment point” is defined as the position inside the ticket to use for the notch alignment. The distance between the notch edge and the alignment point is defined as “Notch Distance”.

Referring to the front of the notch, the value of “Notch Distance” value varies from 0mm minimum and 22mm maximum.

If the “Notch Distance” value is set to 0, the alignment point is set at the beginning of the notch.

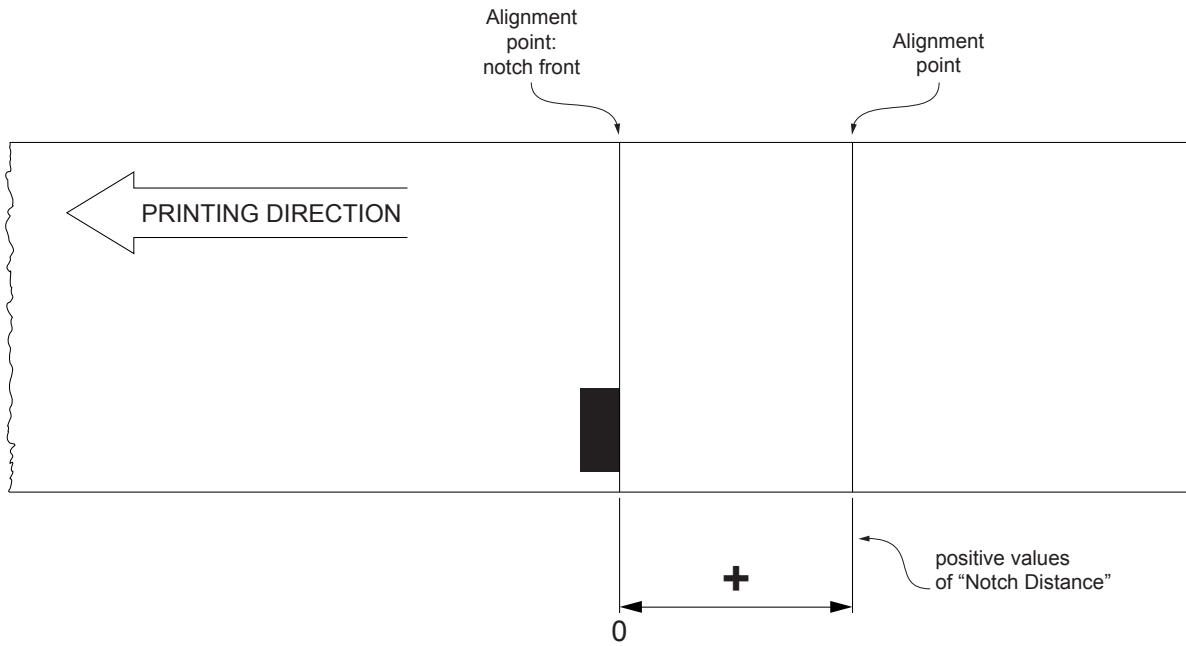

The following figure shows a simplified section of the device with the paper path and the distances (in mm) between the alignment sensor, the print head, cutter (cutting line) and paper out mouth.

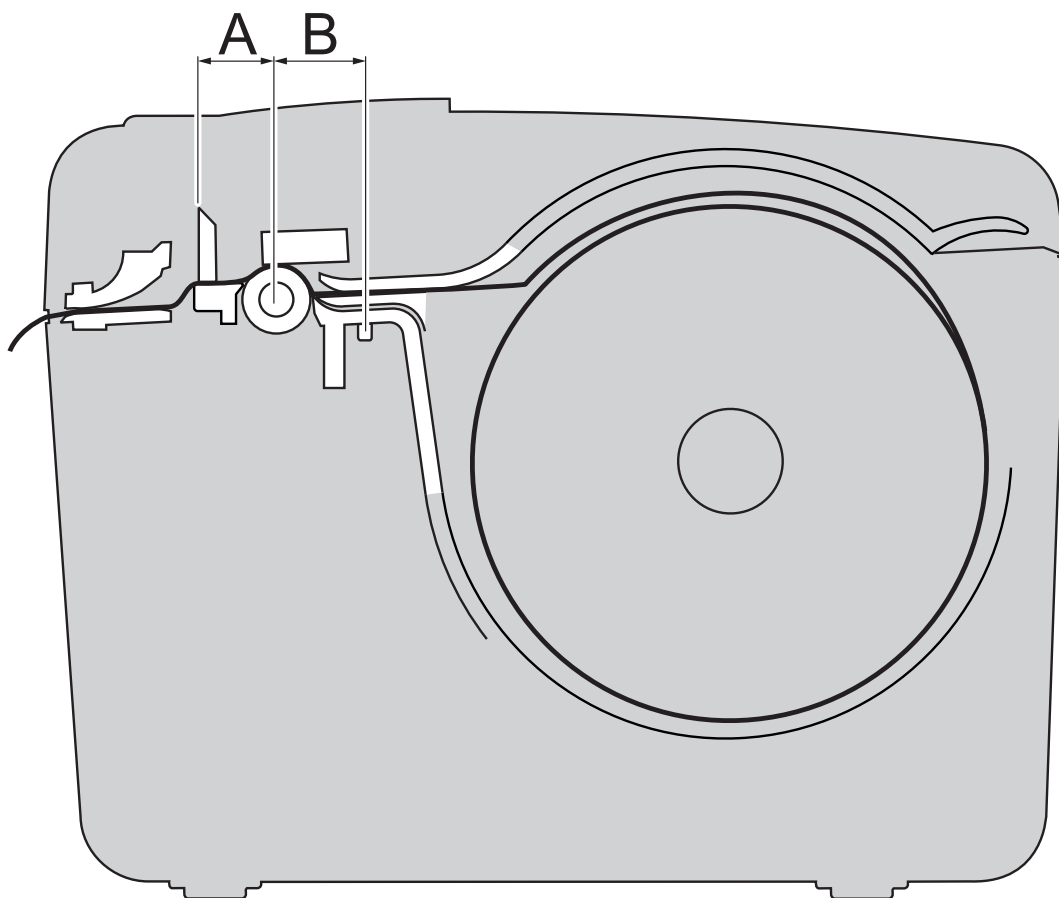

A = distance between printing head and cutter= 15 mm

B = distance between printing head and alignment sensor = 13.5 mm

CUSTOM/POS EMULATION

To define the alignment point you need to set the device parameters that compose the numerical value of the “Notch Distance” parameter. (see par.5.4).

For example, to set a notch distance of 15mm between the notch and the alignment point, the parameters must be set on the following values:

Notch Distance [mm x 10] : 1
Notch Distance [mm x 1] : 5
Notch Distance [mm x .1] : 0

The “Notch Distance” parameter, may be modified as follows:

- during the Setup procedure of the device (see chapter 5)
- by driver

10.4 Printing area

In order to print ticket containing only one notch and to not overlay printing to a notch (that will make it useless for the next alignment), it is important to well calibrate:

- The height of the printing area of ticket according to the inter-notch distance

The following figure shows an example of tickets with “Notch Distance” set to 0:

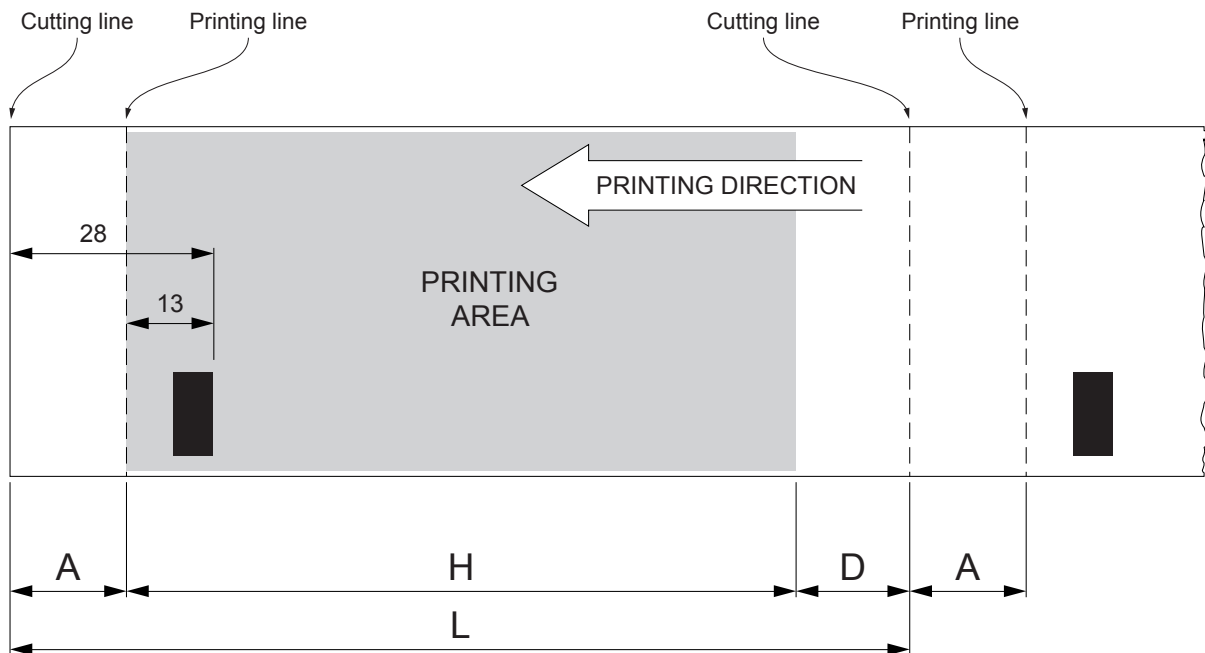

A “Non-printable area” of 15 mm generated from:

“Distance between notch front/cutting line” - “Distance between notch front/printing line”

where:

“Distance between notch front/cutting line” = 28 mm (fixed distance)

“Distance between notch front/printing line” = 13 mm (fixed distance)

H Distance between the first and the last print line, called “Height of the printing area”.

L Ticket length.

D Automatic feed for alignment at the next notch.

To use all the notches on the card, you must comply with the following equation:

$$H + A \leq L$$

The height of the printing area (H) can be increased to make no progress on alignment (D) but no further.

11 TECHNICAL SERVICE

In case of failure, send the 4 pieces of information listed below to our support team:

1. Product code
2. Serial number
3. Hardware release
4. Firmware release

To get the necessary data, proceed as follows:

1



XXXXXXXXXXXXXXXX Rx

00000000000000000000

Write down the data printed on the product label (see paragraph 2.3)

2

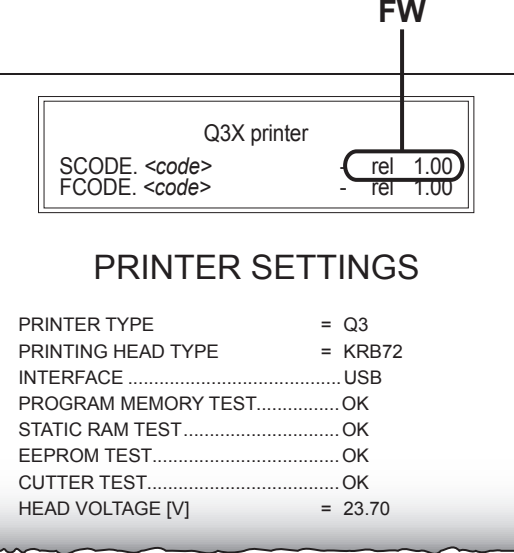

Q3X printer

SCODE: <code> rel 1.00
FCODE: <code> rel 1.00

PRINTER SETTINGS

PRINTER TYPE = Q3
PRINTING HEAD TYPE = KRB72
INTERFACE USB
PROGRAM MEMORY TEST..... OK
STATIC RAM TEST..... OK
EEPROM TEST..... OK
CUTTER TEST..... OK
HEAD VOLTAGE [V] = 23.70

Print a Setup report (see paragraph 5.1)
The Setup report shows the firmware release

3



↓

Customer Service Department:

support@custom.it
(worldwide)

or

support@customamerica.com
(specific for North/South American customers)

Send an e-mail to the Technical Service, with the data collected.

CUSTOM[®]

CUSTOM S.p.A.

World Headquarters

Via Berettine, 2/B - 43010 Fontevivo, Parma ITALY

Tel. +39 0521 680111 - Fax +39 0521 610701

info@custom.biz - www.custom.biz

All rights reserved

www.custom.biz