



Questo manuale d'istruzione è fornito da trovaprezzi.it. Scopri tutte le offerte per [Edimax IGS-1210P](#)
o cerca il tuo prodotto tra le [migliori offerte di Switch](#)



Questo manuale d'istruzione è fornito da trovaprezzi.it. Scopri tutte le offerte per [Edimax IGS-1210P](#)
o cerca il tuo prodotto tra le [migliori offerte di Switch](#)



IGS-1005/IGS-1105P/IGS-1210P

Quick Installation Guide

10-2021 / V1.0

Edimax Technology Co., Ltd.

No. 278, Xinhua 1st Rd., Neihu Dist., Taipei City, Taiwan

Email: support@edimax.com.tw

Edimax Technology Europe B.V.

Fijenhof 2, 5652 AE Eindhoven, The Netherlands

Email: support@edimax.nl

Edimax Computer Company

530 Technology Drive Suite 100, Irvine, CA 92618, USA

Email: support@edimax.us

Contents

I. Product Information	1
I-1. Package Contents	2
I-2. Hardware Interface	3
I-3. LED Status	6
II. Installation.....	8
II-1. Mounting the Switch	8
II-2. Powering the Switch	9
II-2-1. Wiring Power Inputs	9
II-2-2. Wiring P-Fail Alarm Device:	10
II-2-3. DC Power Input:.....	10
II-3. Connecting to Network Devices.....	11

I. Product Information

The IGS-1005, IGS-1105P and IGS-1210P are designed with fanless, DIN-rail, wall-mounted hole and metal case to offer an easy plug-and-play, flexible-deployment, cost-effective, energy efficient solution for users looking to extend networks and fulfill their high bandwidth data transfer and streaming needs.

An ideal solution for industrial networks such as automotive, factory automation, oil and gas, mining, military, transportation, substation, energy and outdoor applications of railways, roads, tunnels, smart cities, city surveillance and traffic monitoring.

You can find all supporting documents from the link below or via QR Code:

<https://www.edimax.com/download>



(Once you've visited the Edimax official website, please enter model no. "IGS-1005, IGS-1105P and IGS-1210P" into the search box to search for your product.)

Download

To select your product and find related download materials, enter the model number into the search box on the right side or follow the simple steps below:

*Feel free to contact us anytime if you need help or if you can't find your product.

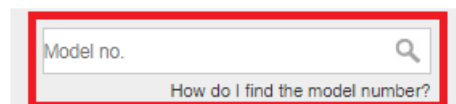

I-1. Package Contents

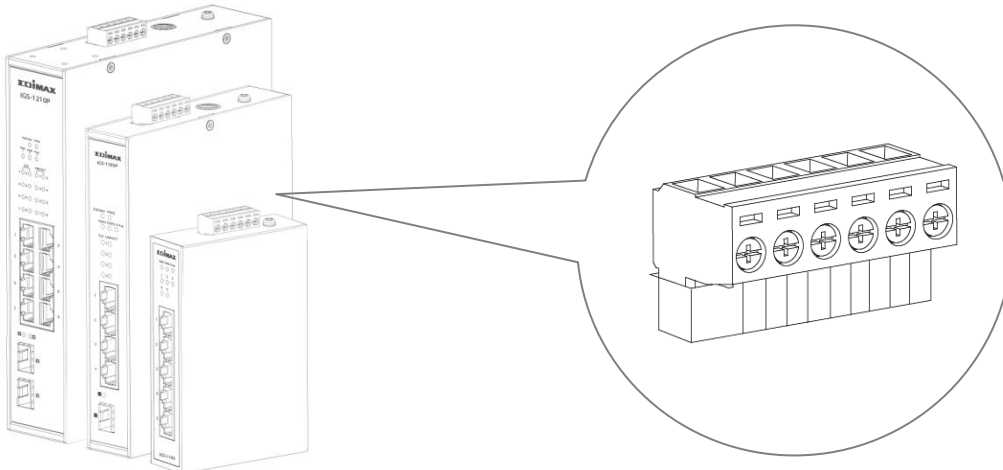

IGS-1005, IGS-1105P or IGS-1210P

DC Power Terminal Block

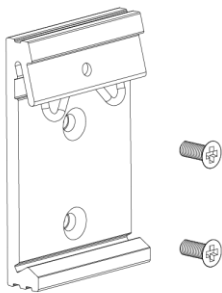

DIN-Rail Mounting Kit



Quick Installation Guide

I-2. Hardware Interface

IGS-1005 Dimension: 127.5(H) x 30(W) x 83.6(D) mm

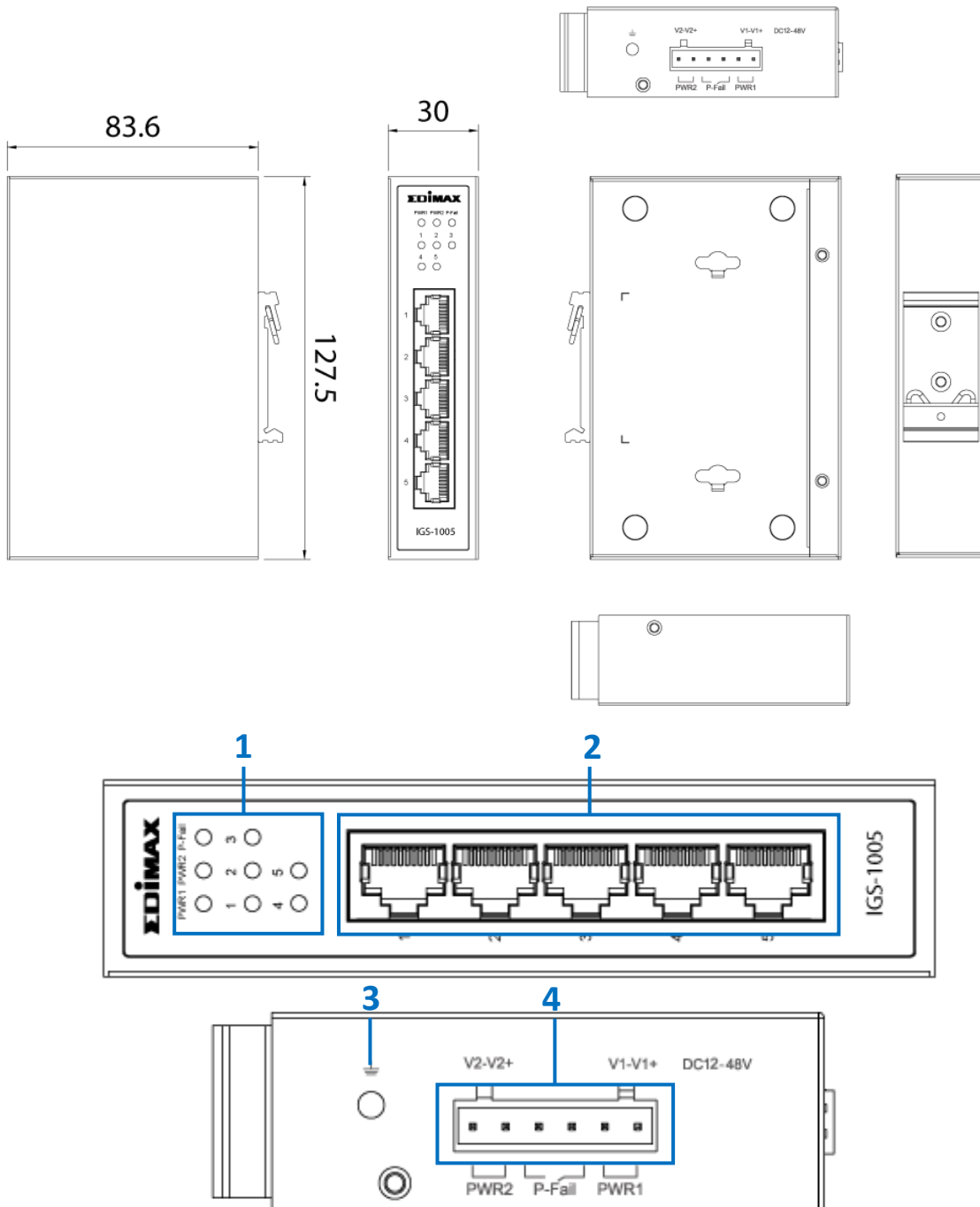

No.	Description
1	LED (PWR1, PWR2, P-Fail, Link/ACT 1~5)
2	LAN Port x 5
3	Grounding Screw
4	Power1/Power2/P-Fail Connector

IGS-1105P Dimension: 180(W) x 130(D) x 32(H) mm

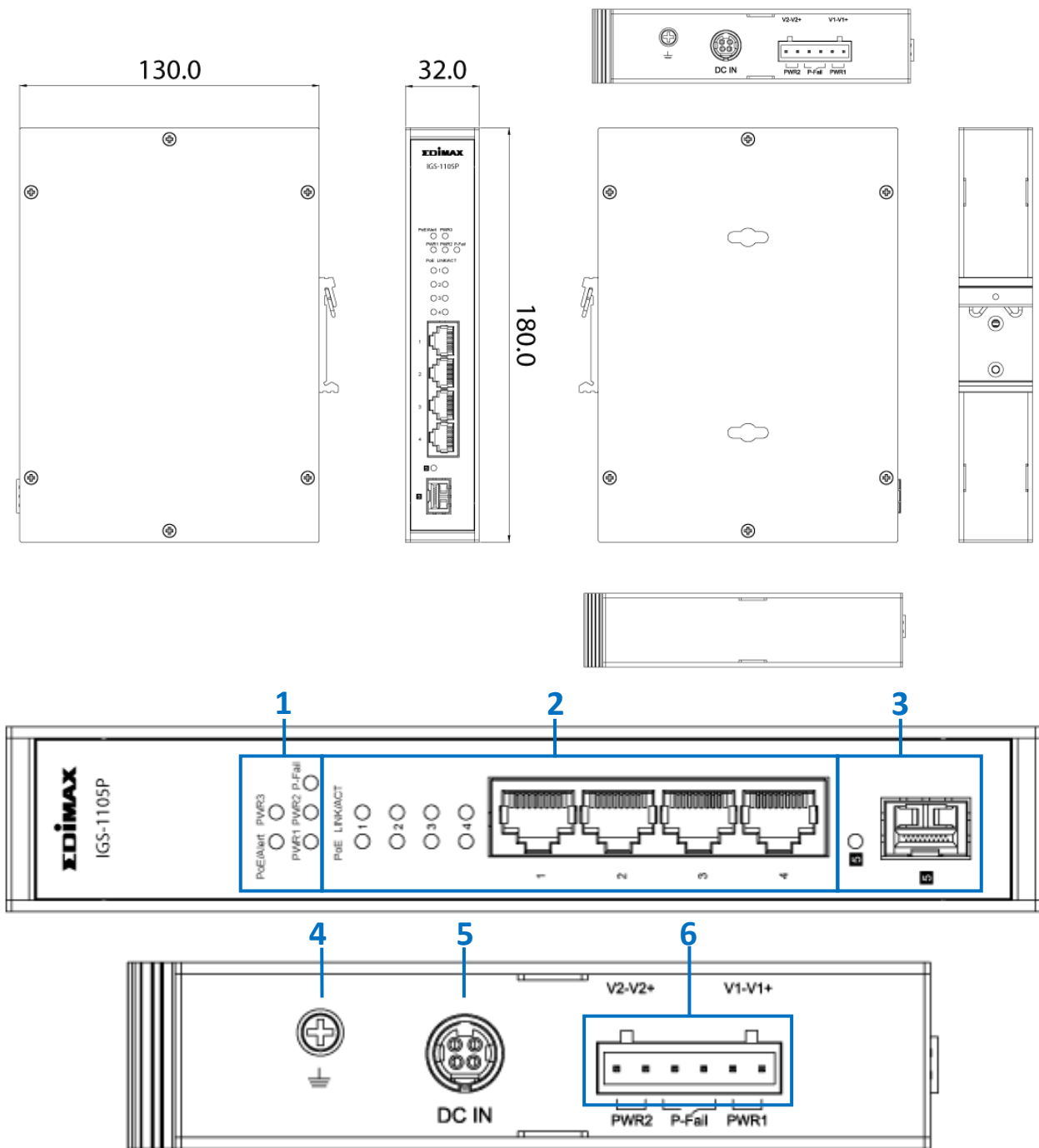

No.	Description
1	LED (PoE/Alert, PWR3, PWR1, PWR2, P-Fail)
2	LED (PoE (1~4), LINK/ACT (1~4)), LAN Port x 4
3	LED (Link/ACT (5)), SFP Port x 1
4	Grounding Screw
5	DC In(48-55V) Power Jack
6	Power1/Power2/P-Fail Connector

IGS-1210P Dimension: 210(H) x 160.6(D) x 46(W) mm

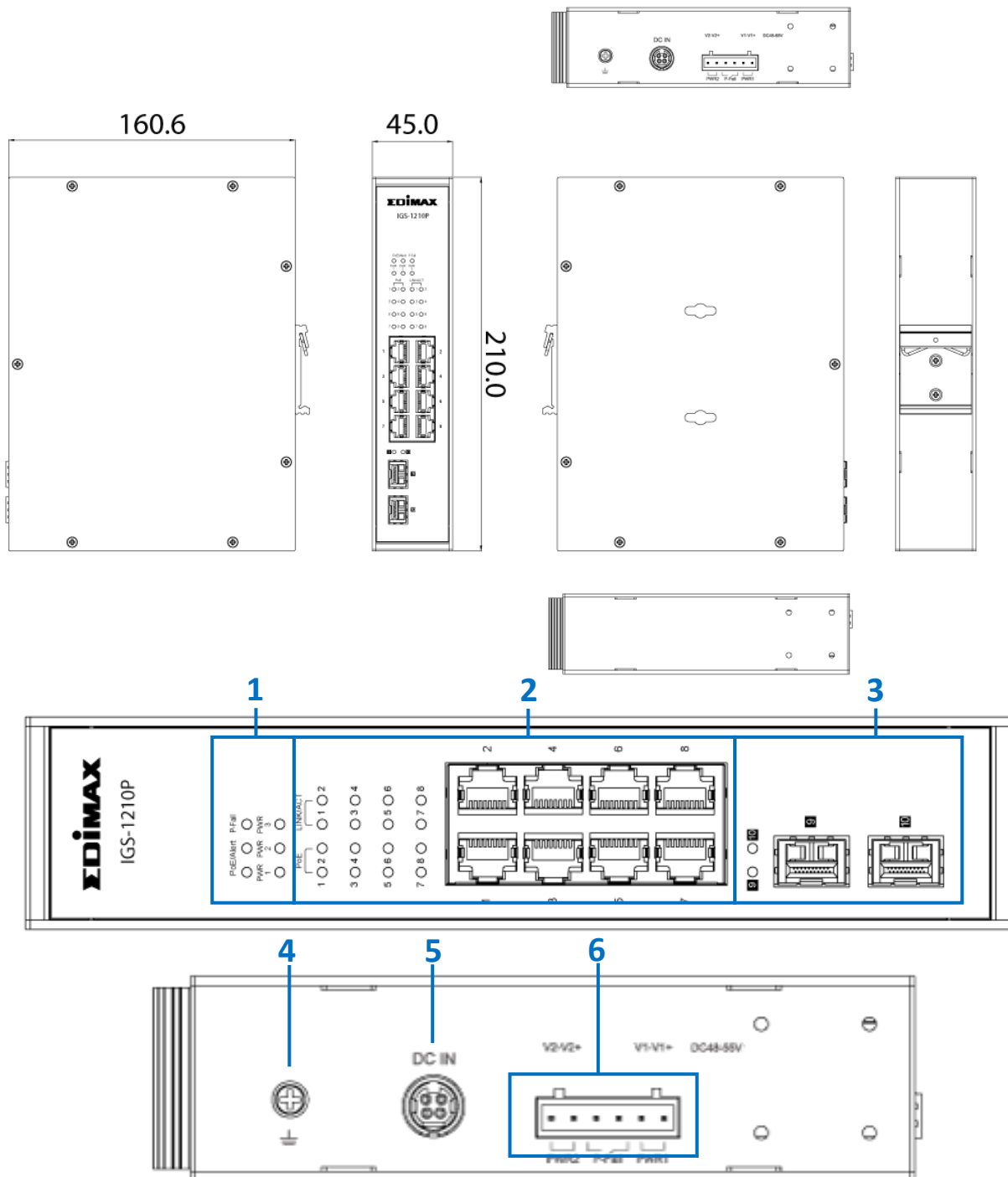

No.	Description
1	LED (PoE/Alert, P-Fail, PWR1, PWR2, PWR3)
2	LED (PoE (1~8), LINK/ACT (1~8)), LAN Port x 8
3	LED (Link/ACT (8~9)), SFP Port x 2
4	Grounding Screw
5	DC In(48-55V) Power Jack
6	Power1/Power2/P-Fail Connector

I-3. LED Status

IGS-1005

LED	Color	Status	Description
P1 (PWR1)	Green	On	The switch is powered by PWR1
		Off	PWR1 is disconnected or failed
P2 (PWR2)	Green	On	The system is powered by PWR2
		Off	PWR2 is disconnected or failed
P-Fail	Green	On	PWR1 or PWR2 is failed.
		Off	The switch is powered by PWR1 and PWR2
Port 1-5 (Link/ACT)	Amber	On	The Port is connected, Link at 10/100M
		Flashing	Sending or receiving data
		Off	The Port is disconnected or link failure
	Green	On	The Port is connected, Link at 1000M
		Flashing	Sending or receiving data
		Off	The Port is disconnected or link failure

IGS-1105P & IGS-1210P

LED	Color	Status	Description
PWR1	Green	On	The system is powered by PWR1
		Off	PWR1 is disconnected or failed
P2 (PWR2)	Green	On	The switch is powered by PWR2
		Off	PWR2 is disconnected or failed
P3 (DC IN)	Green	On	The switch is powered by DC IN
		Off	DC IN is disconnected or failed
P-Fail	Green	On	PWR1 or PWR2 is failed.
		Off	The switch is powered by PWR1 and PWR2
PoE/Alert	Green	On	Total PoE power consumed is exceeding PoE power budget
		Off	Total PoE power consumed is under PoE power budget
PoE	Green	On	Feeding power to PoE devices
		Off	PoE function is not active
LINK/ACT	Amber	On	The Port is connected, Link at 10/100M
		Flashing	Sending or receiving data
		Off	The Port is disconnected or link failure
	Green	On	The Port is connected, Link at 1000M
		Flashing	Sending or receiving data
		Off	The Port is disconnected or link failure
SFP Port	Green	On	The Port is connected, Link at 100/1000M
		Flashing	Sending or receiving data
		Off	The Port is disconnected or link failure

II. Installation

II-1. Mounting the Switch

The industrial switch can be wall-mounted or DIN-Rail mounted. Follow bellow instruction for DIN-Rail mounting.

1. Attach the DIN-rail mounting bracket to the switch.

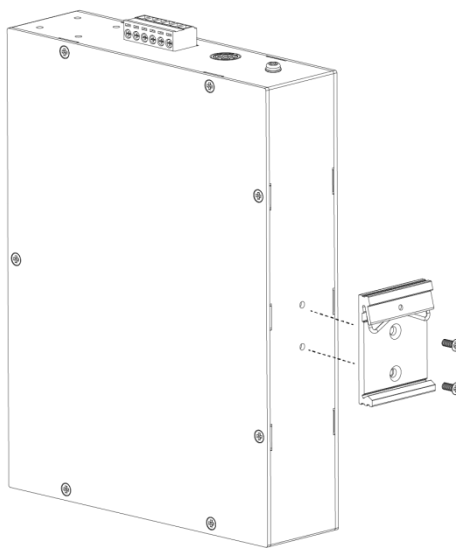

2. Follow the steps below to mount the switch on the DIN-Rail track.

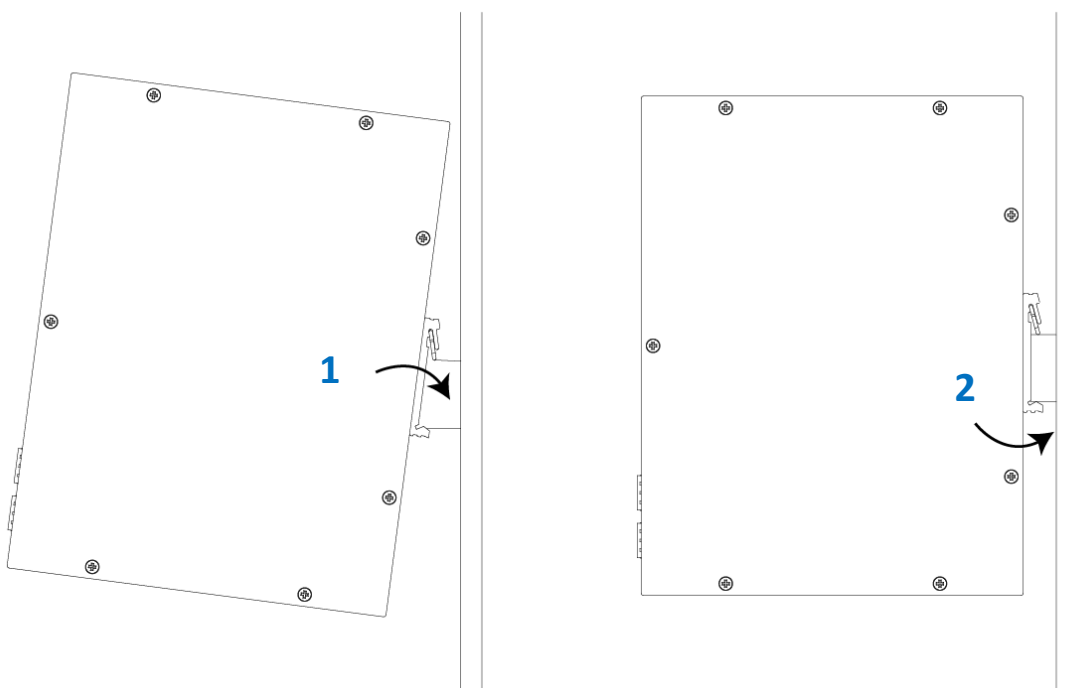

STEP1. Insert the upper end of the DIN-Rail mounting bracket into the DIN-Rail track from its upper side.

STEP2. Lightly push the bottom of the DIN-Rail mounting bracket into the track.

STEP3. Check if the DIN-Rail mounting bracket is tightly attached to the track.

II-2. Powering the Switch

Connect the power source (sold separately) to the switch. Connect the power adapter to the DC-jack or connect a DIN-Rail power source to the power terminal block. (Power adapter and DIN-Rail power supply NOT included)

II-2-1. Wiring Power Inputs

IGS-1005/IGS-1105P/IGS-1210P supports power redundancy. If either power supply fails, the switch will keep operating as usual, and hence guarantees a constant power source for the system.

The P-Fail relay allows taking precautions against potential power failures. (DIN Rail power supply NOT included)

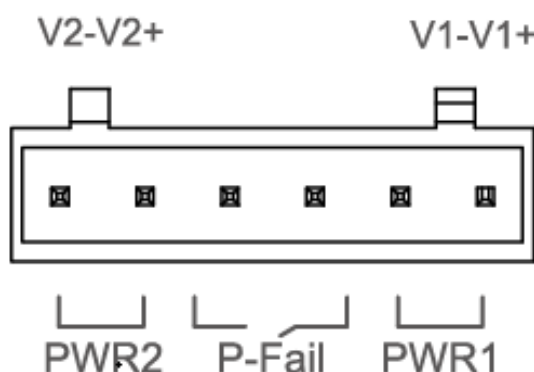

1. Insert the Negative / Positive DC wires into the PWR1 (V1-,V1+) terminals respectively. Tighten the screws to prevent the wires from loosening.
2. **Redundant Power:** Insert the Negative / Positive DC wires into the PWR2 (V2-,V2+) terminals respectively. Tighten the screws to prevent the wires from loosening.

II-2-2. Wiring P-Fail Alarm Device:

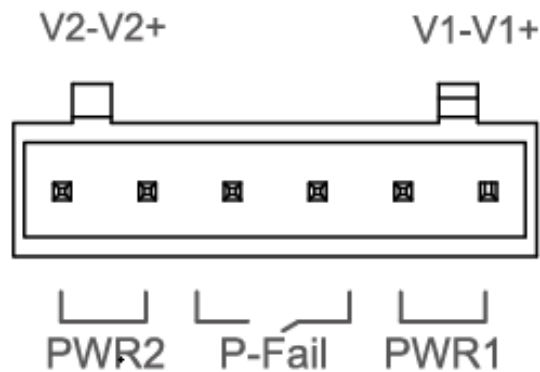

Insert the wires (no electrical polarity) into the **“P-Fail”** terminal block (Fault Alarm Relay). Tighten the screws to prevent the wires from loosening.

Whenever the **“P-Fail”** is triggered, it means one of the power supplies is disconnected or failed.

II-2-3. DC Power Input:

DC Power Input: For IGS-1105P and IGS-1210P ONLY.



DC IN: 48-55VDC, 2A or above

NOTE:

- AC to DC power adaptor NOT included.
- P-Fail won't be triggered when **“DC IN”** is disconnected or failed.

II-3. Connecting to Network Devices

Connect the switch to end nodes using a standard Cat5e Ethernet cable as shown in the illustration below and check the LEDs to confirm the connections are established. The installation procedures have been completed.

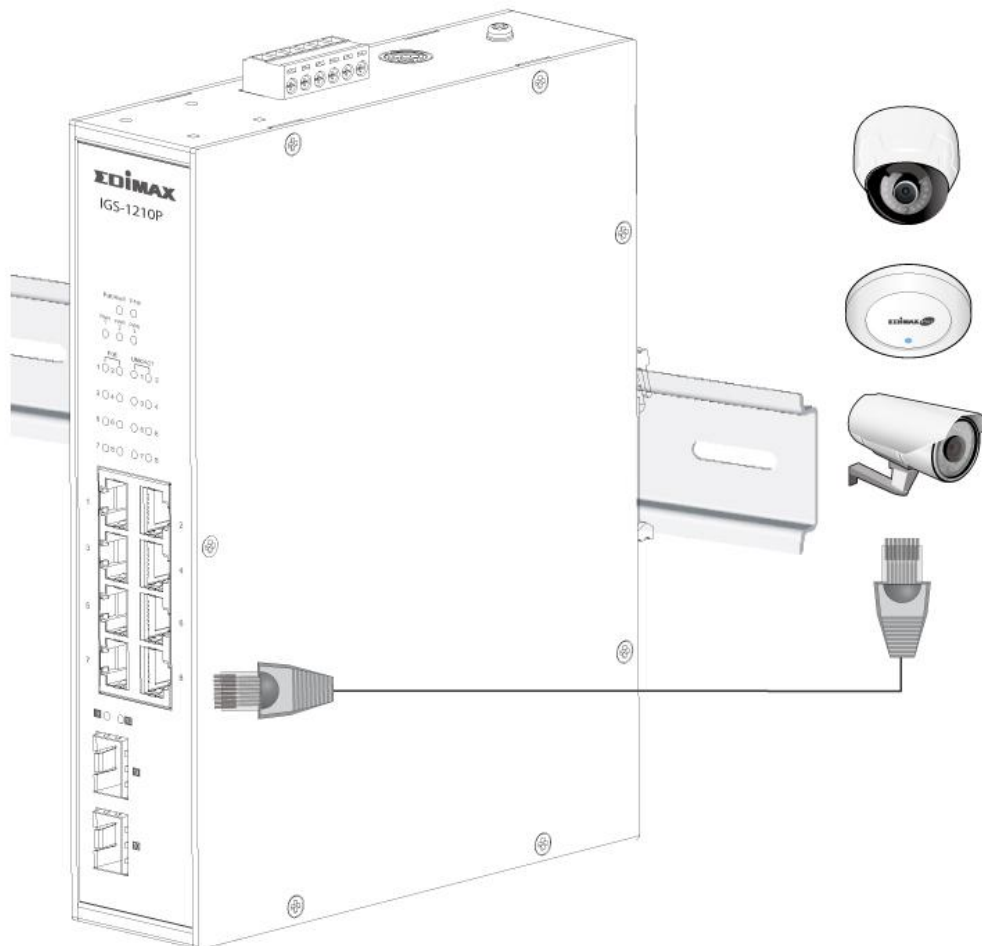

COPYRIGHT

Copyright © Edimax Technology Co., Ltd. all rights reserved. No part of this publication may be reproduced, transmitted, transcribed, stored in a retrieval system, or translated into any language or computer language, in any form or by any means, electronic, mechanical, magnetic, optical, chemical, manual or otherwise, without the prior written permission from Edimax Technology Co., Ltd.

Edimax Technology Co., Ltd. makes no representations or warranties, either expressed or implied, with respect to the contents hereof and specifically disclaims any warranties, merchantability, or fitness for any particular purpose. Any software described in this manual is sold or licensed as is. Should the programs prove defective following their purchase, the buyer (and not this company, its distributor, or its dealer) assumes the entire cost of all necessary servicing, repair, and any incidental or consequential damages resulting from any defect in the software. Edimax Technology Co., Ltd. reserves the right to revise this publication and to make changes from time to time in the contents hereof without the obligation to notify any person of such revision or changes.

The product you have purchased and the setup screen may appear slightly different from those shown in this QIG. The software and specifications are subject to change without notice. Please visit our website www.edimax.com for updates. All brand and product names mentioned in this manual are trademarks and/or registered trademarks of their respective holders.

Federal Communication Commission Interference Statement

This equipment has been tested and found to comply with the limits for a Class A digital device, pursuant to Part 15 of the FCC Rules. These limits are designed to provide reasonable protection against harmful interference when the equipment is operated in a commercial environment. This equipment generates, uses, and can radiate radio frequency energy and, if not installed and used in accordance with the instruction manual, may cause harmful interference to radio communications. Operation of this equipment in a residential area is likely to cause harmful interference in which case the user will be required to correct the interference at his own expense.

FCC Radiation Exposure Statement

This device complies with FCC radiation exposure limits set forth for an uncontrolled environment and it also complies with Part 15 of the FCC RF Rules. This equipment must be installed and operated in accordance with provided instructions and the antenna(s) used for this transmitter must be installed to provide a separation distance of at least 20 cm from all persons and must not be co-located or operating in conjunction with any other antenna or transmitter. End-users and installers must be provided with antenna installation instructions and consider removing the no-collocation statement.

This device complies with Part 15 of the FCC Rules. Operation is subject to the following two conditions:

- (1) this device may not cause harmful interference, and
- (2) this device must accept any interference received, including interference that may cause undesired operation.

Caution!

Any changes or modifications not expressly approved by the party responsible for compliance could void the user's authority to operate the equipment.

R&TTE Compliance Statement

This equipment complies with all the requirements of DIRECTIVE 2014/30/EU OF THE EUROPEAN PARLIAMENT AND THE COUNCIL of March 9, 1999 on radio equipment and telecommunication terminal equipment and the mutual recognition of their conformity (R&TTE). The R&TTE Directive repeals and replaces in the directive 98/13/EEC (Telecommunications Terminal Equipment and Satellite Earth Station Equipment) As of April 8, 2000.

Safety

This equipment is designed with the utmost care for the safety of those who install and use it. However, special attention must be paid to the dangers of electric shock and static electricity when working with electrical equipment. All guidelines of this and of the computer manufacture must therefore be allowed at all times to ensure the safe use of the equipment.

EU Countries Intended for Use

The ETSI version of this device is intended for home and office use in Austria, Belgium, Bulgaria, Cyprus, Czech, Denmark, Estonia, Finland, France, Germany, Greece, Hungary, Ireland, Italy, Latvia, Lithuania, Luxembourg, Malta, Netherlands, Poland, Portugal, Romania, Slovakia, Slovenia, Spain, Sweden, Turkey, and United Kingdom. The ETSI version of this device is also authorized for use in EFTA member states: Iceland, Liechtenstein, Norway, and Switzerland.

EU Countries Not Intended for Use

None

EU Declaration of Conformity

- English:** This equipment is in compliance with the essential requirements and other relevant provisions of Directive 2014/30/EU.
- Français:** Cet équipement est conforme aux exigences essentielles et autres dispositions de la directive 2014/30/EU.
- Čeština:** Toto zařízení je v souladu se základními požadavky a ostatními příslušnými ustanoveními směrnic 2014/30/EU.
- Polški:** Urządzenie jest zgodne z ogólnymi wymaganiami oraz szczególnymi warunkami określonymi Dyrektywą UE 2014/30/EU.
- Română:** Acest echipament este în conformitate cu cerințele esențiale și alte prevederi relevante ale Directivei 2014/30/EU.
- Русский:** Это оборудование соответствует основным требованиям и положениям Директивы 2014/30/EU.
- Magyar:** Ez a berendezés megfelel az alapvető követelményeknek és más vonatkozó irányelveknek (2014/30/EU).
- Türkçe:** Bu cihaz 2014/30/EU. direktifleri zorunlu istekler ve diğer hükümlerle ile uyumludur.
- Українська:** Обладнання відповідає вимогам і умовам директиви 2014/30/EU.
- Slovenčina:** Toto zariadenie spĺňa základné požiadavky a ďalšie príslušné ustanovenia smerníc 2014/30/EU.
- Deutsch:** Dieses Gerät erfüllt die Voraussetzungen gemäß den Richtlinien 2014/30/EU.
- Español:** El presente equipo cumple los requisitos esenciales de la Directiva 2014/30/EU.
- Italiano:** Questo apparecchio è conforme ai requisiti essenziali e alle altre disposizioni applicabili della Direttiva 2014/30/EU.
- Nederlands:** Dit apparaat voldoet aan de essentiële eisen en andere van toepassing zijnde bepalingen van richtlijn 2014/30/EU.
- Português:** Este equipamento cumpre os requisitos essenciais da Directiva 2014/30/EU.
- Norsk:** Dette utstyret er i samsvar med de viktigste kravene og andre relevante regler i Direktiv 2014/30/EU.
- Svenska:** Denna utrustning är i överensstämmelse med de väsentliga kraven och övriga relevanta bestämmelser i direktiv 2014/30/EU.
- Dansk:** Dette udstyr er i overensstemmelse med de væsentligste krav og andre relevante forordninger i direktiv 2014/30/EU.
- suomen kieli:** Tämä laite täyttää direktiivien 2014/30/EU. oleelliset vaatimukset ja muut asiaankuuluvat määräykset.

FOR USE IN

AT	BE	BG	CZ	DK	DE				
EE	IE	EL	ES	FR	HR	IT	CY	LV	LT
LU	HU	MT	NL	PL	PT	RO	SI	SK	FI
SE	UK	UK(PN)	TR	IS	LI	NO	CH	RU	UA



WEEE Directive & Product Disposal



At the end of its serviceable life, this product should not be treated as household or general waste. It should be handed over to the applicable collection point for the recycling of electrical and electronic equipment, or returned to the supplier for disposal.

Declaration of Conformity

We, Edimax Technology Co., Ltd., declare under our sole responsibility, that the equipment described below complies with the requirements of the European R&TTE directives.

Equipment: Industrial 5-Port Gigabit Din-Rail Switch (IGS-1005)
Industrial 5-Port Gigabit PoE+ Din-Rail Switch with 1 SFP (IGS-1105P)
Industrial 10-Port Gigabit PoE+ Din-Rail Switch with 2 SFP (IGS-1210P)
Model No.: IGS-1005/IGS-1105P/IGS-1210P

The following European standards for essential requirements have been followed:

Directives 2014/30/EU

EMC : EN 55032:2015+A11:2020
EN 55035:2017+A11:2020

Directives 2014/35/EU

Safety (LVD) : EN 62368-1:2014+A11:2017

Edimax Technology Europe B.V.
Fijenhof 2,
5652 AE Eindhoven,
The Netherlands

Printed Name: David Huang
Title: Director
Edimax Technology Europe B.V.

a company of:
Edimax Technology Co., Ltd.
No. 278, Xinhua 1st Rd.,
Neihu Dist., Taipei City,
Taiwan



Date of Signature: Oct., 2021

Signature:

A handwritten signature in black ink, appearing to read 'Albert Chang', written over a horizontal line.

Printed Name:

Albert Chang

Title:

Director

Edimax Technology Co., Ltd.

Declaration of Conformity

We, Edimax Technology Co., Ltd., declare under our sole responsibility, that the equipment described below complies with the requirements of the United Kingdom EMC and Safety directives.

Equipment: Industrial 5-Port Gigabit Din-Rail Switch (IGS-1005)
Industrial 5-Port Gigabit PoE+ Din-Rail Switch with 1 SFP (IGS-1105P)
Industrial 10-Port Gigabit PoE+ Din-Rail Switch with 2 SFP (IGS-1210P)
Model No.: IGS-1005/IGS-1105P/IGS-1210P

The following European standards for essential requirements have been followed:

Electromagnetic Compatibility Regulations 2016 (S.I. 2016/1091)

EMC : EN 55032:2015+A11:2020
EN 55035:2017+A11:2020

Electrical Equipment (Safety) Regulations 2016 (S.I. 2016/1101)

Safety (LVD) : EN 62368-1:2014+A11:2017

Edimax Technology Europe B.V.
Fijenhof 2,
5652 AE Eindhoven,
The Netherlands

Printed Name: David Huang
Title: Director
Edimax Technology Europe B.V.

a company of:
Edimax Technology Co., Ltd.
No. 278, Xinhua 1st Rd.,
Neihu Dist., Taipei City,
Taiwan



Date of Signature: Oct., 2021

Signature: _____

A handwritten signature in black ink, appearing to read 'Albert Chang', written over a horizontal line.

Printed Name: Albert Chang

Title: Director

Edimax Technology Co., Ltd.