



Questo manuale d'istruzione è fornito da trovaprezzi.it. Scopri tutte le offerte per [Epson SureColor SC-P6500D](#) o cerca il tuo prodotto tra le [migliori offerte di Plotter](#)



Questo manuale d'istruzione è fornito da trovaprezzi.it. Scopri tutte le offerte per [Epson SureColor SC-P6500D](#) o cerca il tuo prodotto tra le [migliori offerte di Plotter](#)

**EPSON**<sup>®</sup>  
EXCEED YOUR VISION

**SC-P8500DM Series / SC-P8500D Series /  
SC-P6500D Series / SC-P6500DE Series /  
SC-P6500E Series**

**SC-T7700DM Series / SC-T5700DM Series /  
SC-T7700D Series / SC-T5700D Series /  
SC-T3700D Series / SC-T3700DE Series /  
SC-T3700E Series**

**SC-P8500DL Series / SC-T7700DL Series**

# User's Guide

---

## Copyrights and Trademarks

---

# Copyrights and Trademarks

No part of this publication may be reproduced, stored in a retrieval system, or transmitted in any form or by any means, electronic, mechanical, photocopying, recording, or otherwise, without the prior written permission of Seiko Epson Corporation. The information contained herein is designed only for use with this Epson printer. Epson is not responsible for any use of this information as applied to other printers.

Neither Seiko Epson Corporation nor its affiliates shall be liable to the purchaser of this product or third parties for damages, losses, costs, or expenses incurred by the purchaser or third parties as a result of accident, misuse, or abuse of this product or unauthorized modifications, repairs, or alterations to this product, or (excluding the U.S.) failure to strictly comply with Seiko Epson Corporation's operating and maintenance instructions.

Seiko Epson Corporation shall not be liable for any damages or problems arising from the use of any options or any consumable products other than those designated as Original Epson Products or Epson Approved Products by Seiko Epson Corporation.

Seiko Epson Corporation shall not be held liable for any damage resulting from electromagnetic interference that occurs from the use of any interface cables other than those designated as Epson Approved Products by Seiko Epson Corporation.

EPSON, EPSON EXCEED YOUR VISION, EXCEED YOUR VISION, and their logos are registered trademarks or trademarks of Seiko Epson Corporation.

Microsoft<sup>®</sup>, Windows<sup>®</sup>, and Windows Vista<sup>®</sup> are registered trademarks of Microsoft Corporation.

Mac, macOS, OS X, Bonjour, Safari, and AirPrint are trademarks of Apple Inc., registered in the U.S. and other countries.

Chrome<sup>™</sup>, Chrome OS<sup>™</sup>, and Android<sup>™</sup> are trademarks of Google Inc.

Intel<sup>®</sup> is a registered trademark of Intel Corporation.

Adobe and Reader are either registered trademarks or trademarks of Adobe in the United States and/or other countries.

HP-GL/2<sup>®</sup> and HP RTL<sup>®</sup> are registered trademarks of Hewlett-Packard Corporation.

ICC profiles made by X-Rite solutions are included.

*General Notice: Other product names used herein are for identification purposes only and may be trademarks of their respective owners. Epson disclaims any and all rights in those marks.*

© 2022 Seiko Epson Corporation.

## Contents

# Contents

## Copyrights and Trademarks

## Introduction

Notes on Manuals. . . . .	7
Meaning of Symbols. . . . .	7
Illustrations. . . . .	7
Product Model Descriptions. . . . .	7
Manual Organization. . . . .	7
Viewing Video Manuals. . . . .	7
Viewing PDF Manuals. . . . .	8
Printer Parts. . . . .	9
Front Section. . . . .	9
Around the Roll Paper. . . . .	10
Around the Ink Cartridges (Except for the SC-P8500DL Series/SC-T7700DL Series). . . . .	12
Around the Ink Supply Unit (SC-P8500DL Series/SC-T7700DL Series). . . . .	13
Back. . . . .	14
Inside. . . . .	15
Scanner (SC-P8500DM Series/SC-T7700DM Series/SC-T5700DM Series only). . . . .	16
Control panel. . . . .	17
Home screen operations. . . . .	18
Features. . . . .	20
Realizing High Resolution. . . . .	20
Notes on Usage and Storage. . . . .	20
Installation space. . . . .	20
Notes when using the printer. . . . .	21
Notes when not using the printer. . . . .	21
Notes when using the control panel. . . . .	22
Notes on handling ink cartridges (only for models with ink cartridges). . . . .	22
Notes on handling the ink supply units (only for models with ink supply units). . . . .	23
Notes on handling paper. . . . .	23
Saving Power. . . . .	24

## Introducing the Software

Supplied Software. . . . .	26
Pre-installed Software. . . . .	27
Using Epson Media Installer. . . . .	28
Starting Procedure. . . . .	28
Configuration of main screen. . . . .	29
Edit Media Settings Screen Configuration. . . . .	32
Adding Paper Information. . . . .	34
Editing Paper Information. . . . .	34

Sharing Paper Information with Multiple Computers. . . . .	34
Using Web Config. . . . .	35
Starting Procedure. . . . .	35
Closing Procedure. . . . .	35
Function Summary. . . . .	36
Using Epson Edge Dashboard. . . . .	36
Starting Procedure. . . . .	36
Closing Procedure. . . . .	36
Using EPSON Software Updater. . . . .	37
Checking software update availability. . . . .	37
Receiving update notifications. . . . .	37
Updating Software or Installing Additional Software. . . . .	37
Checking software update availability. . . . .	37
Receiving update notifications. . . . .	38
Uninstalling Software. . . . .	38
Windows. . . . .	38
Mac. . . . .	39

## Changing the Network Connection Methods

Switching to Wired LAN. . . . .	40
Switching to Wireless LAN. . . . .	40
Directly Connecting Wirelessly (Wi-Fi Direct). . . . .	41

## Basic Operations

Notes on Loading the Paper. . . . .	42
Loading and Removing the Roll Paper. . . . .	42
Loading Roll 1/Roll paper. . . . .	42
Removing Roll 1/Roll paper. . . . .	44
Loading Roll 2 (Except for the SC-P6500E Series/SC-T3700E Series). . . . .	46
Removing Roll 2 (Except for the SC-P6500E Series/SC-T3700E Series). . . . .	48
Loading and Removing Cut Sheets/Poster Board. . . . .	50
Loading Cut Sheets. . . . .	50
Loading Poster Board. . . . .	53
Removing Cut Sheets/Poster Board. . . . .	56
Setting Loaded Paper. . . . .	56
How to Set. . . . .	57
When the paper type is not displayed on the control panel or in the driver. . . . .	58
Optimizing Media Settings (Automatic Adjustment). . . . .	61

**Contents**

Precautions when performing Print Adjustments. . . . . 61

Automatic Adjustment Procedure. . . . . 62

If you cannot perform Automatic Adjustment. . . 62

Feeding Roll Paper Manually. . . . . 63

Loading Paper for Auto Take-up (Except for the SC-P6500E Series/SC-T3700E Series). . . . . 63

    Loading Method for Auto Take-up. . . . . 64

    Removing Method for Auto Take-up. . . . . 68

Basic Printing Methods(Windows). . . . . 70

Basic Printing Methods(Mac). . . . . 73

Printable area. . . . . 75

    Roll Paper Printable Area. . . . . 75

    Cut Sheets Printable Area. . . . . 75

Turning Off the Power Using Power Off Timer. . . . 76

Canceling Printing. . . . . 76

**Adobe® PostScript® 3™ Expansion Unit**

When Printing Using the Adobe® PostScript® 3™ Expansion Unit Fails or is Interrupted. . . . . 78

**Using the SSD Unit (Optional)**

Using the SSD Unit from the Printer Driver. . . . . 79

Creating a Storage Space. . . . . 80

Saving Data to Storage. . . . . 81

    Saving a Document from your Computer to Storage (Windows). . . . . 81

    Saving a Document from your Computer to Storage (Mac). . . . . 81

    Saving Data from a Memory Device to Storage. . 81

Using Data Saved to Storage. . . . . 82

    Printing Data in Storage. . . . . 82

Managing Storage Spaces and Documents. . . . . 82

    Searching for Storage Spaces and Documents. . . 82

    Deleting a Document from Storage. . . . . 82

    Changing the Storage Period or Setting to Indefinite. . . . . 82

    Deleting a Storage Space. . . . . 83

    Restricting Operations for Shared Storage Spaces. . . . . 83

**Various Printing Methods**

Enlargements and Horizontal and Vertical Banners. . . . . 84

Fitting Documents to the Width of the Roll Paper. . . . . 84

    Choosing a Print Size. . . . . 85

    Fitting Documents to the Output Size. . . . . 86

Printing at Non-Standard Sizes. . . . . 88

Printing CAD Drawings. . . . . 90

    Printing Using CAD/Line Drawing Mode in the Printer Driver. . . . . 90

    Printing Using HP-GL/2 and HP RTL Emulation. . . . . 91

Automatically Switch Roll Paper for Printing (Except for the SC-P6500E Series/SC-T3700E Series). . . . . 91

    Switching Between Roll 1 and Roll 2 According to the Paper Type. . . . . 91

    Switching Between Roll 1 and Roll 2 According to the Page Size. . . . . 93

    Start Printing from Roll with Least Amount Remaining, and Switch Between Roll 1 and Roll 2 when Paper Runs Out. . . . . 94

Borderless Printing. . . . . 96

    Types of Borderless Printing Methods. . . . . 96

    Supported Paper. . . . . 96

    About Roll Paper Cutting. . . . . 97

    Setting Procedures for Printing. . . . . 98

    Correct color and print. . . . . 99

N-up/Poster. . . . . 102

    Folded Double-Side (Windows only). . . . . 103

    Multi-Page Printing (N-up). . . . . 103

    Poster (Windows Only). . . . . 104

Poster Layout(Windows only). . . . . 109

    Setting Procedures for Printing. . . . . 110

    Saving and Recalling Settings. . . . . 110

Using Epson Smart Panel (Except for Models that do not Support Wireless LAN). . . . . 111

Using AirPrint. . . . . 111

Printing Over the Web (Upload Printing). . . . . 112

    Function Summary. . . . . 112

    Upload and Print Procedure. . . . . 112

Printing Files in a Shared Folder (Folder Printing) 113

    Function Summary. . . . . 113

    Preparing a Shared Folder. . . . . 113

    Print from Folder Procedure. . . . . 114

Printing Files Directly from a USB Flash Drive. . . 114

**Color Management Printing**

About Color Management. . . . . 116

Color Management Print Settings. . . . . 116

## Contents

Setting profiles. . . . .	117
Setting color management with applications. . . . .	117
Setting Color Management with the Printer Driver. . . . .	118
Color Management Printing by Host ICM (Windows). . . . .	118
Color Management Printing by ColorSync (Mac). . . . .	119
Color Management Printing by Driver ICM(Windows only). . . . .	120

### **Using the Printer Driver(Windows)**

Displaying the Settings Screen. . . . .	122
With the Start button. . . . .	122
Displaying Help. . . . .	123
Click the Help Button to Display. . . . .	123
Right-click on the item you want to check and display. . . . .	123
Customizing the Printer Driver. . . . .	124
Saving various settings as your Select Settings. . . . .	124
Summary of the Utility Tab. . . . .	125

### **Using the Printer Driver(Mac)**

Displaying the Settings Screen. . . . .	126
Displaying Help. . . . .	126
Using Presets. . . . .	126
Saving Presets. . . . .	126
Deleting Presets. . . . .	127
Using Epson Printer Utility 4. . . . .	127
Starting Epson Printer Utility 4. . . . .	127
Epson Printer Utility 4 Functions. . . . .	127

### **Copy (SC-P8500DM Series/SC-T7700DM Series/SC-T5700DM Series Only)**

Placing Documents in the Scanner. . . . .	129
Loadable Document Sizes. . . . .	129
Loadable Paper Types. . . . .	129
Documents That Cannot Be Loaded. . . . .	130
When loading documents that are thin, that are easily torn, or that you do not want to damage. . . . .	130
Procedure for Copying. . . . .	132

### **Scan (SC-P8500DM Series/SC-T7700DM Series/SC-T5700DM Series Only)**

Function Summary. . . . .	134
Preparing to Scan. . . . .	134
Procedure for Scanning. . . . .	135
Saving Scanned Images to Your Computer. . . . .	136

### **Menu List**

Paper Setting. . . . .	138
General Settings. . . . .	147
Supply Status. . . . .	160
Maintenance. . . . .	161
Language. . . . .	161
Printer Status/Print. . . . .	162
Contacts Manager (SC-P8500DM Series/SC-T7700DM Series/SC-T5700DM Series only). . . . .	162
User Settings (Except for the SC-P8500DM Series/SC-T7700DM Series/SC-T5700DM Series) . . . . .	163
User Settings (SC-P8500DM Series/SC-T7700DM Series/SC-T5700DM Series). . . . .	163
Authentication Device Status. . . . .	163
Epson Open Platform Information. . . . .	163
Copy (SC-P8500DM Series/SC-T7700DM Series/SC-T5700DM Series Only). . . . .	163
Scan (SC-P8500DM Series/SC-T7700DM Series/SC-T5700DM Series Only). . . . .	164
Memory Device. . . . .	167
Network Folder. . . . .	170
Storage (Only when an SSD Unit is Installed). . . . .	171

### **Maintenance**

Print Head Maintenance. . . . .	172
Maintenance Operations. . . . .	172
Print Head Nozzle Check. . . . .	172
Print Head Cleaning. . . . .	173
Paper Feed Adjust. . . . .	175
Ruled Line Alignment. . . . .	176
Replacing Consumables. . . . .	177
Replacing Ink Cartridges (Except for the SC-P8500DL Series/SC-T7700DL Series). . . . .	177
Replacing Ink Supply Units (SC-P8500DL Series/SC-T7700DL Series Only). . . . .	179
Replacing the Maintenance Box and Borderless Maintenance Box. . . . .	180
Replacing the auto cutter blade. . . . .	184

**Contents**

Cleaning the Printer. . . . . 186  
 Cleaning the outside. . . . . 186  
 Cleaning the inside. . . . . 186

**Problem Solver**

When a Message is Displayed. . . . . 188  
 When an Error Message and Error Code are Displayed. . . . . 189  
 Troubleshooting. . . . . 190  
     You cannot print (because the printer does not work). . . . . 190  
     The printer sounds like it is printing, but nothing prints. . . . . 192  
     The prints are not what you expected. . . . . 193  
     Feeding or ejecting problems. . . . . 203  
     Others. . . . . 207  
 Copying or Scanning Problems (SC-P8500DM Series/SC-T7700DM Series/SC-T5700DM Series Only). . . . . 209

**Appendix**

Options and Consumable Products. . . . . 214  
     Epson Special Media. . . . . 214  
     Ink Cartridges (Except for the SC-P8500DL Series/SC-T7700DL Series). . . . . 214  
     Ink Supply Units (SC-P8500DL Series/SC-T7700DL Series). . . . . 217  
     Others. . . . . 219  
 Supported Media. . . . . 220  
     Epson Special Media Table. . . . . 220  
     Supported Commercially Available Paper. . . . . 229  
     Supported Paper Widths. . . . . 230  
     Before Printing on Commercially Available Paper. . . . . 231  
 Moving or Transporting the Printer. . . . . 233  
     Moving to Another Location in the Same Building. . . . . 234  
     Transporting the Printer. . . . . 235  
     If the Environment Indoors or During Transportation Drops to -10 °C or Lower. . . . . 236  
 System Requirements. . . . . 237  
     Printer Driver. . . . . 237  
     Web Config. . . . . 239  
 Specifications Table (Except for the SC-P8500DL Series/SC-T7700DL Series). . . . . 240  
 Specifications Table (SC-P8500DL Series/SC-T7700DL Series Only). . . . . 243

**Where To Get Help**

Technical Support Web Site. . . . . 247  
 Contacting Epson Support. . . . . 247  
     Before Contacting Epson. . . . . 247  
     Help for Users in North America. . . . . 247  
     Help for Users in Europe. . . . . 248  
     Help for Users in Taiwan. . . . . 248  
     Help for Users in Australia/New Zealand. . . . . 248  
     Help for Users in Singapore. . . . . 249  
     Help for Users in Thailand. . . . . 249  
     Help for Users in Vietnam. . . . . 249  
     Help for Users in Indonesia. . . . . 249  
     Help for Users in Hong Kong. . . . . 250  
     Help for Users in Malaysia. . . . . 250  
     Help for Users in India. . . . . 250  
     Help for Users in the Philippines. . . . . 251

## Introduction

# Introduction

## Notes on Manuals

### Meaning of Symbols

 <b>Warning:</b>	Warnings must be followed to avoid serious bodily injury.
---	---

 <b>Caution:</b>	Cautions must be followed to avoid bodily injury.
---	---

 <b>Important:</b>	Important must be followed to avoid damage to this product.
---	---

<b>Note:</b>	Notes contain useful or additional information on the operation of this product.
--------------	--

	Indicates related reference content.
---	--------------------------------------

## Illustrations

The illustrations may differ slightly from the model you are using. Please be aware of this when using the manuals.

## Product Model Descriptions

Some models described in this manual may not be sold in your country or region.

## Manual Organization

The manuals for the product are organized as shown below.

You can view the PDF manuals using Adobe Acrobat Reader or Preview (Mac).

Setup Guide (booklet)	Provides information on how to setup the printer after unpacking it from the box. Make sure you read this manual to perform operations safely.
Pin-up Manuals	Provides explanations for basic printer operations. Print it out and put it up on a wall near to the printer.
General Information (PDF)	Provides printer specifications and contact details.
Online Manual	
User's Guide (this manual)	Provides overall information and instructions on using the printer and on solving problems.
Administrator's Guide (PDF)	Provides network administrators with information on management and printer settings.
Epson Video Manuals	Provides videos on performing a variety of maintenance procedures.

## Viewing Video Manuals

The video manuals have been uploaded to YouTube.

You can view them by clicking **Epson Video Manuals (video)** from the top page of the Online Manual, or by clicking the following blue text.

[Video Manuals](#)

## Introduction

If the subtitles are not displayed when you play the video, click the subtitles icon shown in the image below.

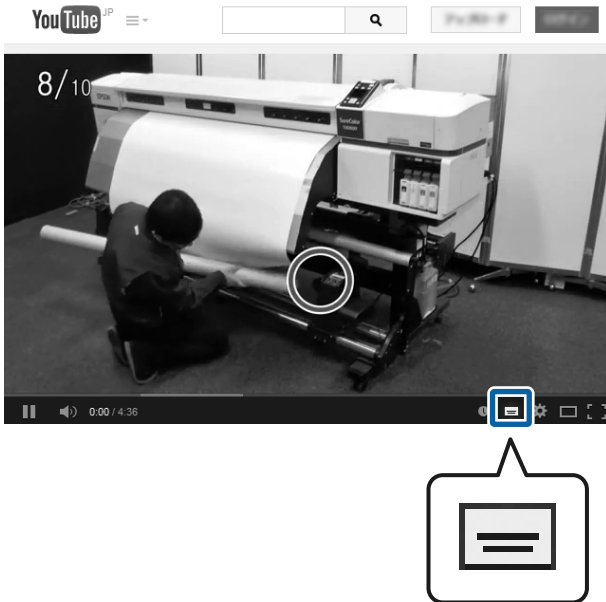

- 3 Click the title to open the relevant page.

Click [+] to open the titles lower in the hierarchy.

- 4 If the reference is in blue text, click the blue text to open the relevant page.

To return to the previous page, do the following.

### For Windows

While pressing the Alt key, press the ← key.

### For Mac

While pressing the command key, press the ← key.

- 5 You can input and search for keywords, such as the names of items you want to confirm.

### For Windows

Right click on a page in the PDF manual and select **Find** in the menu that is displayed to open the search toolbar.

### For Mac

Select **Find** in the **Edit** menu to open the search toolbar.

- 6 To enlarge the text in the display that is too small to see well, click ⊕. Click ⊖ to reduce the size. To specify a part of an illustration or screenshot to enlarge, do the following.

### For Windows

Right click on the page in the PDF manual and select **Marquee Zoom** in the menu that is displayed. The pointer changes to a magnifying glass, use it to specify the range of the place you want to enlarge.

### For Mac

Click **View** menu - **Zoom** - **Marquee Zoom** in this order to change the pointer to a magnifying glass. Use the pointer as a magnifying glass to specify the range of the place you want to enlarge.

- 7 Opens the previous page or next page.

## Viewing PDF Manuals

This section uses Adobe Acrobat Reader DC as an example to explain the basic operations for viewing the PDF in Adobe Acrobat Reader.

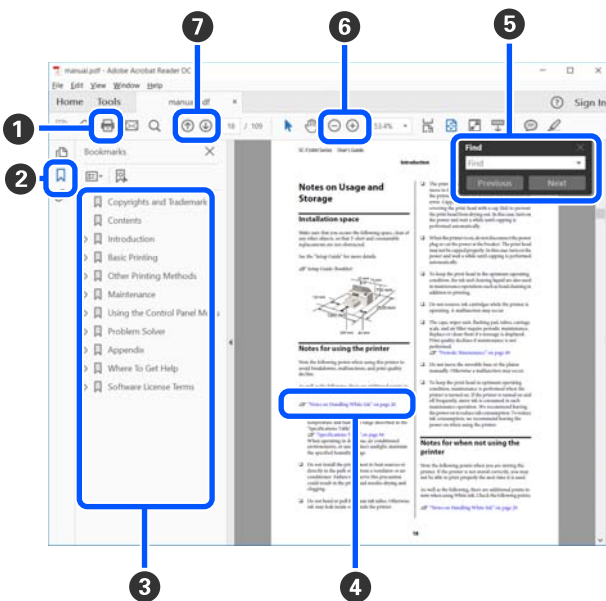

- 1 Click to print the PDF manual.
- 2 Each time it is clicked, the bookmarks are hidden or shown.

## Introduction

# Printer Parts

## Front Section

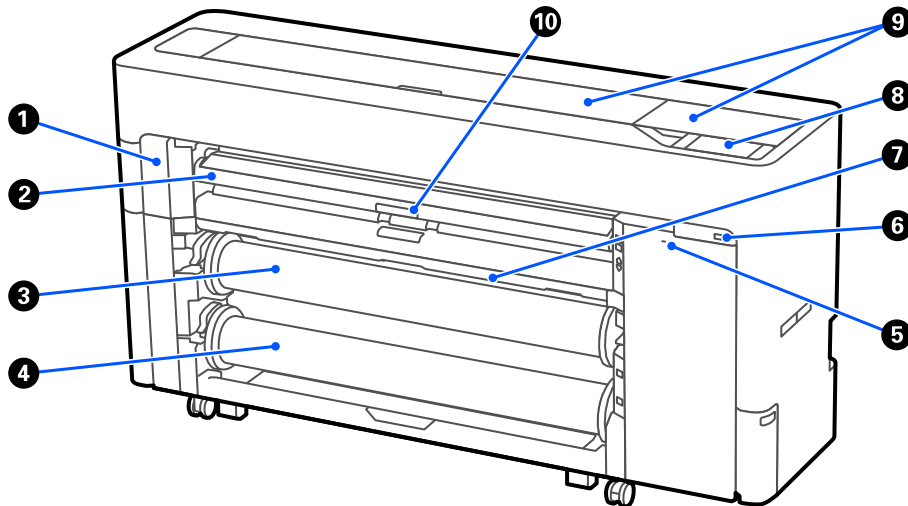

### 1 Maintenance cover

Open when replacing the auto cutter blade.

[“Replacing the auto cutter blade” on page 184](#)

### 2 Paper support

Change the position for feeding roll paper, cut sheets, and poster board. Also, when replacing the Borderless Maintenance Box, set it to the top position.

### 3 Roll 1 (Known as Roll paper on the SC-P6500E Series/SC-T3700E Series.)

This can also be used to take-up media.

[“Loading Paper for Auto Take-up \(Except for the SC-P6500E Series/SC-T3700E Series\)” on page 63](#)

### 4 Roll 2 (Not available on the SC-P6500E Series/SC-T3700E Series.)

[“Loading Roll 2 \(Except for the SC-P6500E Series/SC-T3700E Series\)” on page 46](#)

### 5 Security lock slot

You can install a security lock for theft prevention.

### 6 USB memory port

You can connect a USB flash drive to print directly.

[“Printing Files Directly from a USB Flash Drive” on page 114](#)

### 7 Paper basket

## Introduction

### 8 Control panel

The printer is equipped with a 4.3-inch touch panel.

### 9 Printer cover

Open this cover when cleaning the inside of the printer or clearing jams.

### 10 Paper support lock lever

The paper support lock lever.

## Around the Roll Paper

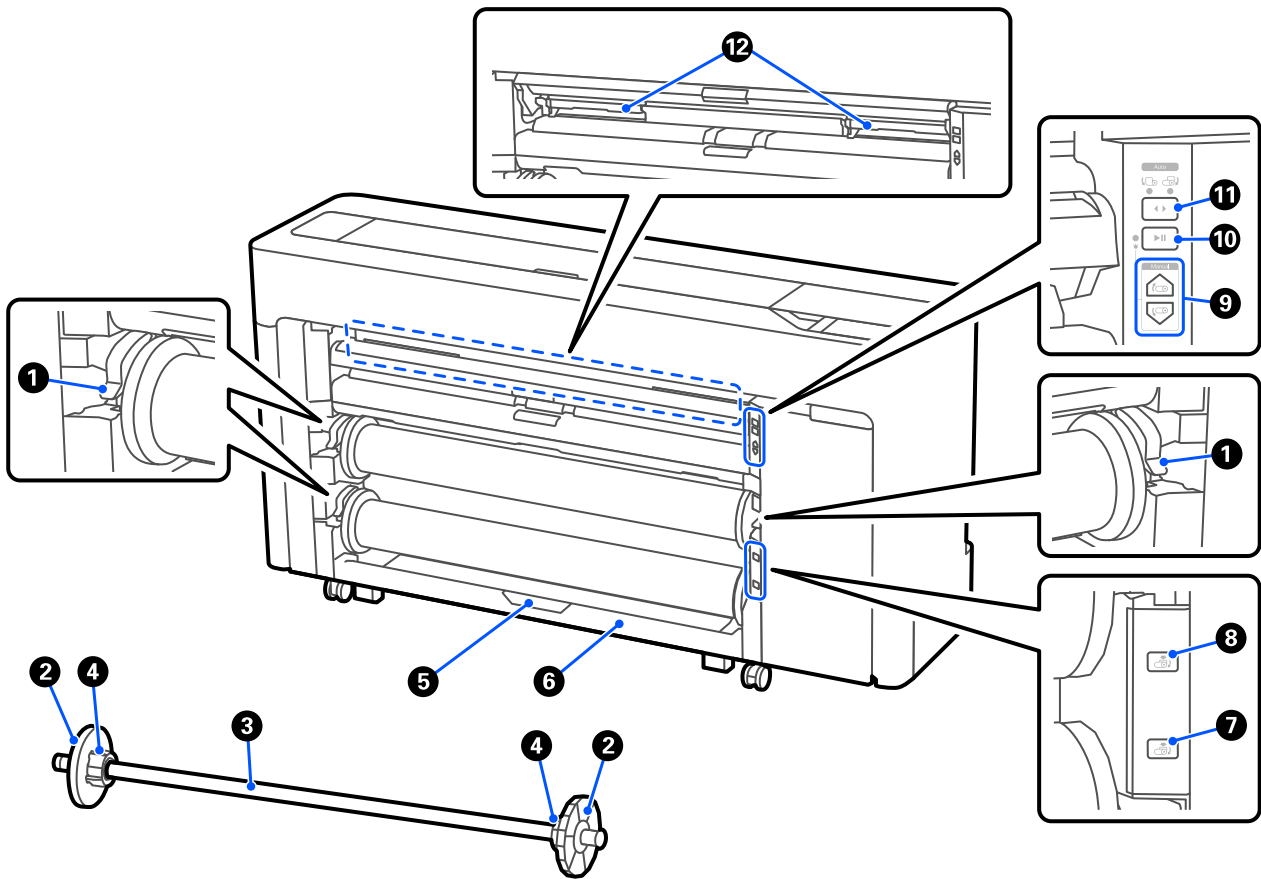

### 1 Spindle lock lever

The spindle lock lever.

### 2 Media edge guide

This fixes the roll paper placed on the spindle. Attach or remove the transparent media edge guide when loading roll paper.

### 3 Spindle

When loading roll paper, insert this through the roll paper.

## Introduction

### 4 Core adapter

Attach or remove the core adapter according to the size of the roll paper core.

 [“Loading and Removing the Roll Paper” on page 42](#)

### 5 Roll2 unit lock lever (Not available on the SC-P6500E Series/SC-T3700E Series.)

The roll2 unit lock lever.

### 6 Roll 2 unit (Not available on the SC-P6500E Series/SC-T3700E Series.)

The unit for loading roll2.

 [“Loading Roll 2 \(Except for the SC-P6500E Series/SC-T3700E Series\)” on page 46](#)

### 7 Roll2 removal button (Not available on the SC-P6500E Series/SC-T3700E Series.)

Ejects and rewinds media for roll 2.

### 8 Roll1 removal button

Ejects and rewinds media for roll 1.

### 9 Manual take-up button (Not available on the SC-P6500E Series/SC-T3700E Series.)

Use this to take-up or rewind media when roll 1 is set to automatic take-up.

 [“Loading Paper for Auto Take-up \(Except for the SC-P6500E Series/SC-T3700E Series\)” on page 63](#)

### 10 Pause/resume button (Not available on the SC-P6500E Series/SC-T3700E Series.)

Use this to pause and resume take-up when roll 1 is set to automatic take-up.

 [“Loading Paper for Auto Take-up \(Except for the SC-P6500E Series/SC-T3700E Series\)” on page 63](#)

### 11 Take-up direction switch (Not available on the SC-P6500E Series/SC-T3700E Series.)

When using roll 1 for automatic take-up, select the take-up direction (printed side out/printed side in).

 [“Loading Paper for Auto Take-up \(Except for the SC-P6500E Series/SC-T3700E Series\)” on page 63](#)

### 12 Borderless Maintenance Box

Maintenance box for borderless printing.

 [“Replacing the Borderless Maintenance Box” on page 182](#)

## Introduction

### Around the Ink Cartridges (Except for the SC-P8500DL Series/ SC-T7700DL Series)

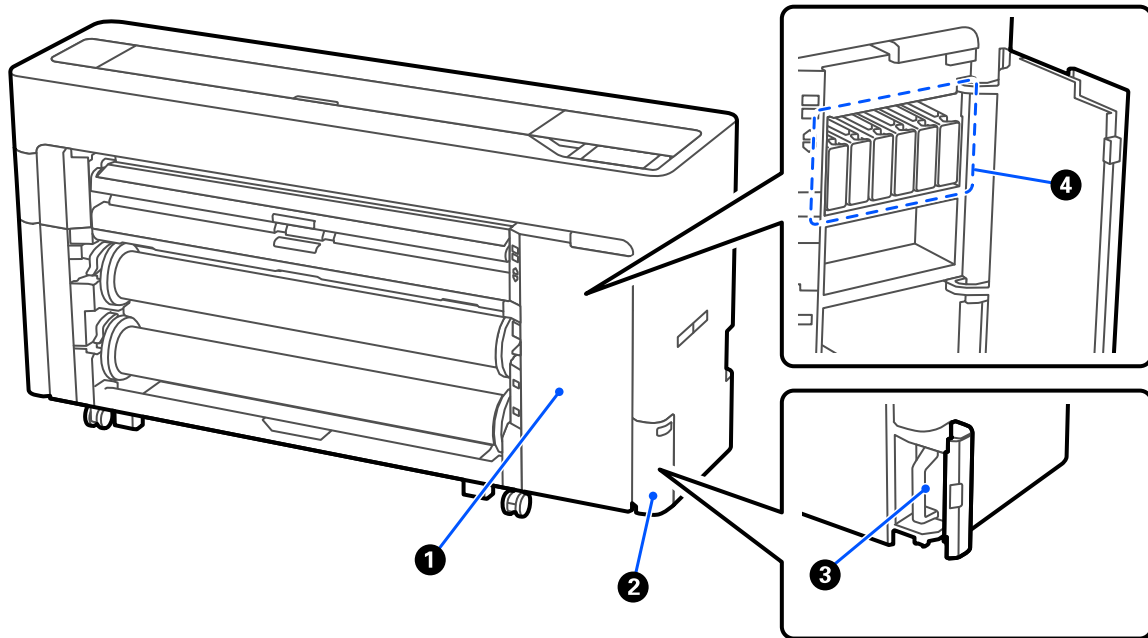

#### ① Ink cartridge cover

Open when replacing ink cartridges.

 [“Replacing Ink Cartridges \(Except for the SC-P8500DL Series/SC-T7700DL Series\)”](#) on page 177

#### ② Maintenance box cover

Open when replacing the maintenance box .

 [“Replacing the Maintenance Box”](#) on page 181

#### ③ Maintenance box

#### ④ Ink Cartridges

**Introduction**

**Around the Ink Supply Unit (SC-P8500DL Series/SC-T7700DL Series)**

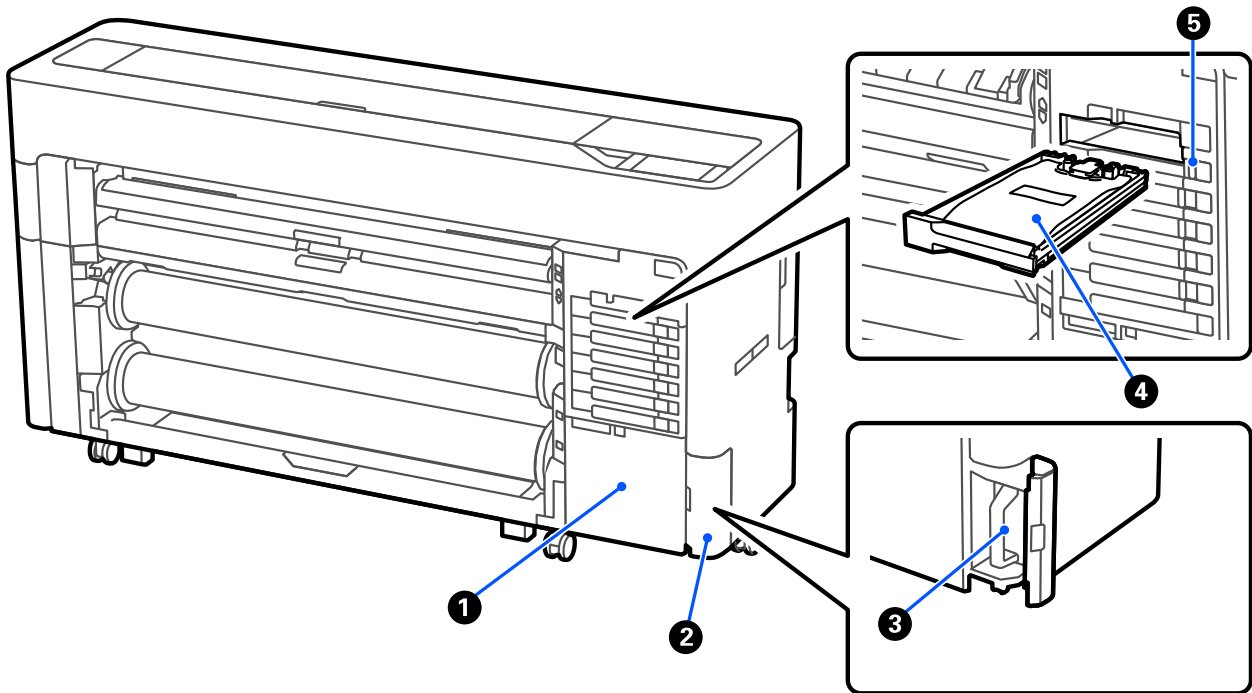

**1 Accessory case**

**2 Maintenance box cover**

Open when replacing the maintenance box .

[“Replacing the Maintenance Box” on page 181](#)

**3 Maintenance box**

**4 Ink Supply Unit**

[“Replacing Ink Supply Units \(SC-P8500DL Series/SC-T7700DL Series Only\)” on page 179](#)

**5 Lock switch**

## Introduction

### Back

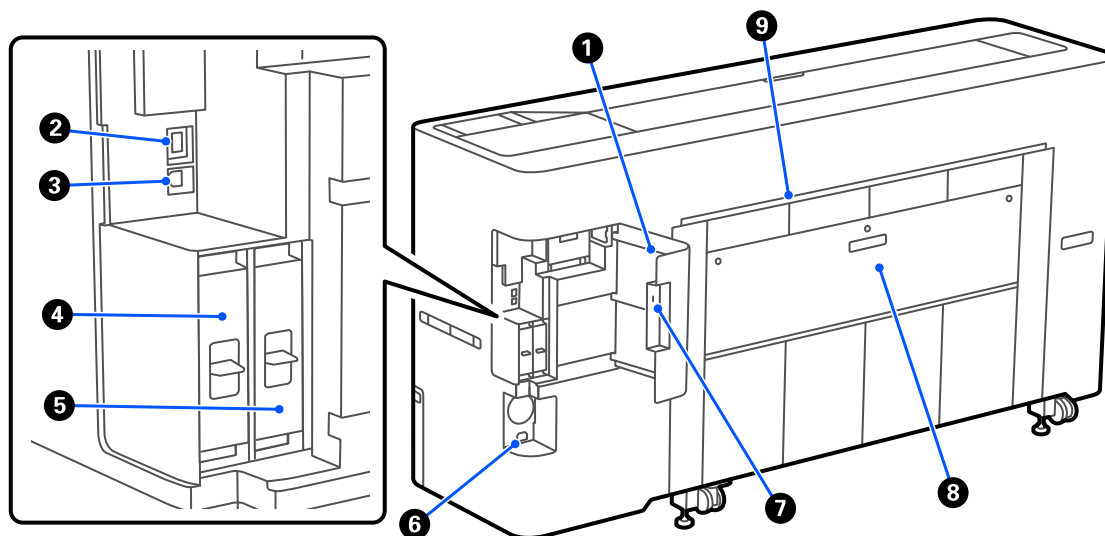

**1 Port cover**

**2 LAN port**

Connects the LAN cable.

**3 USB port**

Connect to your computer with a USB cable.

**4 Optional storage unit slot**

The SC-P8500DM Series/SC-T7700DM Series/SC-T5700DM Series come with an SSD Unit installed. Models other than the SC-P8500DM Series/SC-T7700DM Series/SC-T5700DM Series can be equipped with the optional SSD Unit.

**5 Adobe® PostScript® 3™ expansion unit**

The printer is equipped with the Adobe® PostScript® 3™ expansion unit. (Not included with some models.)

**6 DC inlet**

Connect the supplied power cable here.

**7 Security lock slot**

You can install a security lock for theft prevention.

**8 Rear cover 1**

**9 Cut sheet/Poster board paper slot (rear)**

Paper slot for feeding cut sheet/poster board from the rear.

 [“Loading and Removing Cut Sheets/Poster Board” on page 50](#)

## Introduction

### Inside

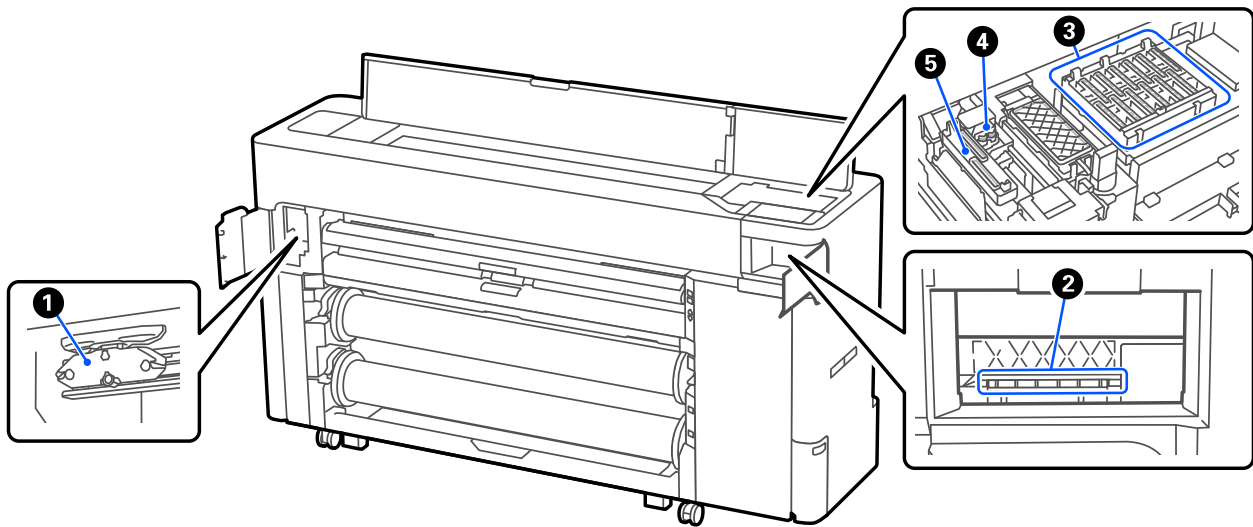

#### 1 Auto cutter blade

If the paper is not cut neatly, replace the auto cutter blade.

 [“Replacing the auto cutter blade” on page 184](#)

#### 2 Print head

Try cleaning it when automatic cleaning does not clear clogging in the print head.

 [“Cleaning around the print head and caps” on page 196](#)

#### 3 Capping stations

Except when printing, these caps cover the print head nozzles to prevent them from drying. Try cleaning it when automatic cleaning does not clear clogging in the print head.

 [“Cleaning around the print head and caps” on page 196](#)

#### 4 Wipers

Used to wipe off ink that is stuck to the surface of the print head nozzles. Try cleaning these when automatic cleaning does not clear clogging in the print head.

 [“Cleaning around the print head and caps” on page 196](#)

#### 5 Suction Cap

During head cleaning, this cap sucks the optimum amount of ink from the print head nozzles. Try cleaning these when automatic cleaning does not clear clogging in the print head.

 [“Cleaning around the print head and caps” on page 196](#)

## Introduction

---

### Scanner (SC-P8500DM Series/SC-T7700DM Series/SC-T5700DM Series only)

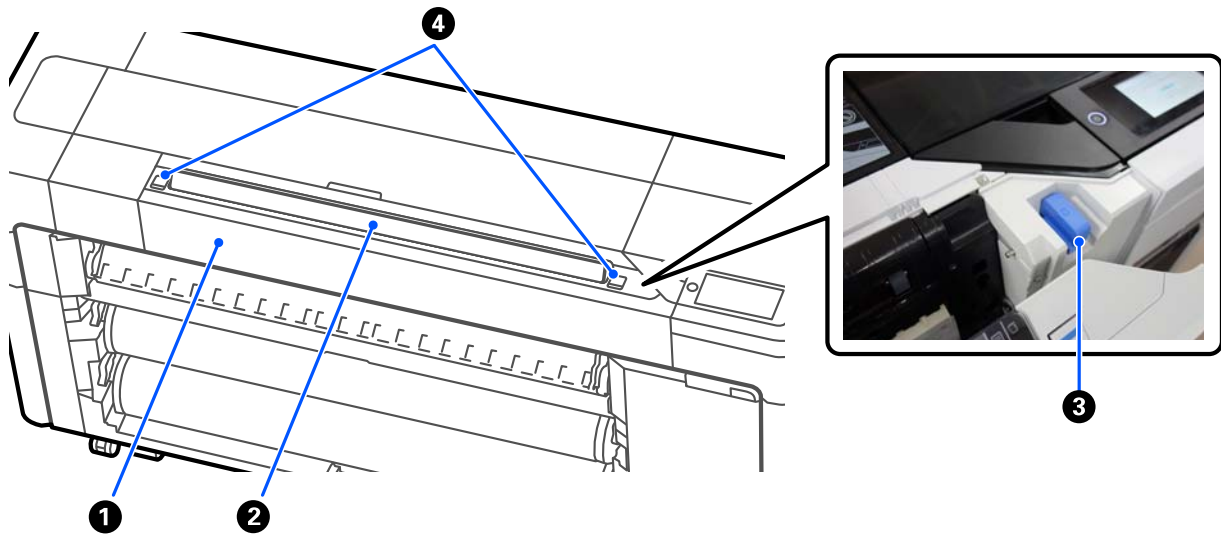

**1 Scanner cover**

Open this cover when a paper jam occurs and so on.

**2 Scanner slot**

Insert originals to be scanned.

**3 Scanner edge guide**

Store the scanner edge guide when you open the scanner cover. This guide allows you to feed originals straight into the printer.

**4 Lock lever**

Open the scanner cover while pressing the left and right lock levers.

## Introduction

### Control panel

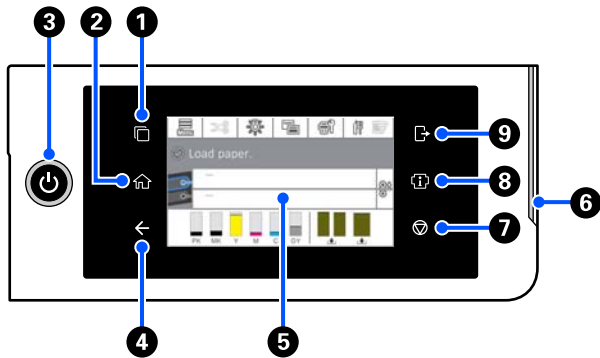

#### 1 Authentication system switching button

Lit when an authentication system is connected.  
Press to switch the authentication system.

#### 2 Home button

Press this button while a menu is displayed to return to the Home screen. The light is off when it cannot be used during operations such as paper feeding.

#### 3 button (power button)

#### 4 Back button (authentication system only)

Lit when an authentication system is connected.

#### 5 Control panel

This is a touch panel to display the printer's status, menus, error messages, and so on.

#### 6 Alert lamp

Turns on to notify you when an error has occurred.  
You can check the details of the error on the control panel.

#### 7 button (stop button)

Press to stop operations.

#### 8 Information button

You can check the status of the printer by viewing consumable information and the list of messages.  
You can also check the job history.

#### Note:

SC-P8500DM Series/SC-T7700DM Series/  
SC-T5700DM Series Only

Press the Information button, and then press  to operate the scanner. Press to open the scanner cover or to remove scanned originals.

#### 9 Authentication system logout button

Lit when an authentication system is connected.  
Press to log out of the authentication system.

## Introduction

### Home screen operations

The home screen varies depending on the printer model. You can also switch the home screen using the screen switching button.

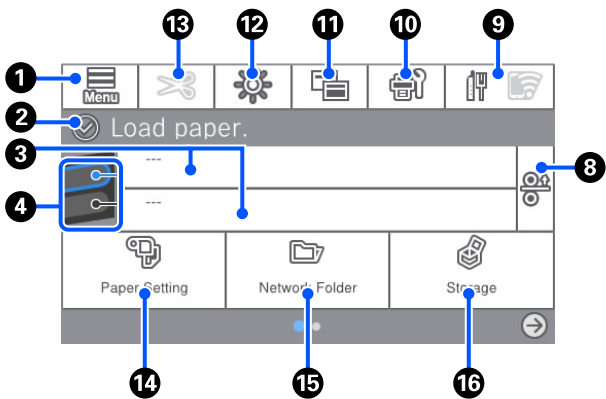
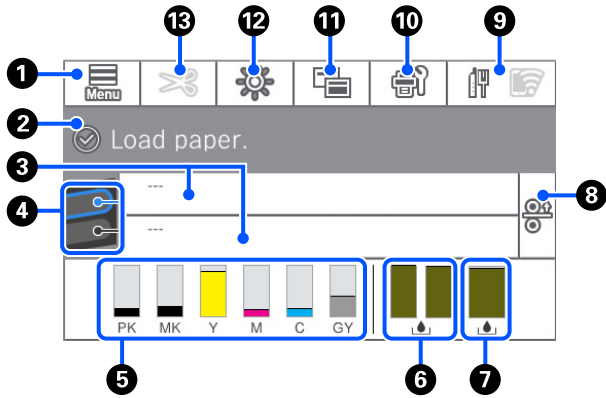

SC-P8500DM Series/SC-T7700DM Series/  
SC-T5700DM Series Only

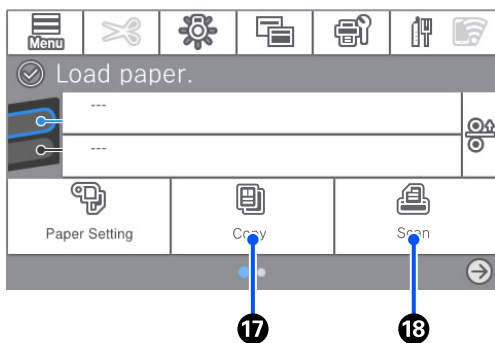

**1 Menu**

Allows you to make paper settings, printer settings, and perform printer maintenance. See the following for a list of the menus.

[“Menu List” on page 138](#)

**2 Information display area**

Displays the printer's status, error messages, and so on.

**3 Paper loading information**

Displays paper information for the loaded paper.

**4 Reserve Paper Switching**

Press during printing to switch to the paper from the selected paper source to use it for the next page. You can select this when there is no paper loaded in either paper source. Press during printing to display the Paper Setting screen.

**5 Displays the ink levels**

Displays the amount of ink remaining. The abbreviation below the bar indicates the ink color.

PK : Photo Black

MK : Matte Black

Y : Yellow

M : Magenta

C : Cyan

GY : Gray (SC-P Series)

R : Red (SC-T Series)

When is displayed, the corresponding ink is running low. Press the display area to check the model number for the ink cartridge or ink supply unit.

**6 Displays the amount of space remaining in the Borderless Maintenance Box.**

## Introduction

Displays the approximate amount of available space in the Borderless Maintenance Box for borderless printing. When  is displayed, the amount of empty space in the Borderless Maintenance Box is low. Press the display area to check the Borderless Maintenance Box model number.

### 7 Displays the amount of space remaining in the Maintenance Box

Displays the approximate amount of available space in the Maintenance Box. When  is displayed, the amount of empty space in the Maintenance Box is low. Press the display area to check the Maintenance Box model number.

### 8 Paper Release

Releases the paper allowing you to pull it out. This is disabled during paper feeding or printing.







### 9 Network icon

The network connection status is indicated by an icon as shown below.

Pressing the icon allows you to switch the network connection status.

 [“Changing the Network Connection Methods” on page 40](#)

Wireless LAN may not be supported depending on the specifications and destination. In this case, use a wired LAN.

	Not connected to a wired LAN or the wired LAN or wireless LAN not set.
	Connected to a wired LAN.
	Wireless LAN (Wi-Fi) is disabled.
	Searching for SSID, IP address not set, or signal strength is 0 or poor.
	Connected to a wireless LAN (Wi-Fi). The number of lines indicates the signal strength. The more lines there are, the better the signal strength.
	Wi-Fi Direct (simple AP) connection is disabled.

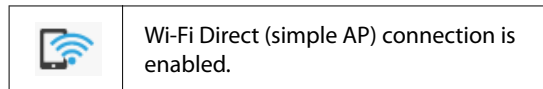

### 10 Maintenance

You can check and clean the print head nozzles, replace consumables, and clean parts.

### 11 Switch screens

You can switch the Home screen display.

### 12 Inside Light

You can turn the internal lighting on or off. Turn on the internal light when you want to check the print as it is being printed.

### 13 Feed/Cut Paper

When roll paper is loaded, you can perform paper feed adjustments, cut the paper, and make cutting settings.

### 14 Paper Setting menu button

Press this button when loading, removing, setting, or adjusting paper.

### 15 Folder printing

You can print a file from a shared folder on the network that has been setup in advance.

 [“Printing Files in a Shared Folder \(Folder Printing\)” on page 113](#)

### 16 Storage Settings

Displayed when the SSD Unit is installed. You can make storage settings which allow you to store documents in the SSD unit and print them when needed.

### 17 Copy

 [“Copy \(SC-P8500DM Series/SC-T7700DM Series/SC-T5700DM Series Only\)” on page 129](#)

### 18 Scanner

 [“Scan \(SC-P8500DM Series/SC-T7700DM Series/SC-T5700DM Series Only\)” on page 134](#)

**Introduction**

**Features**

The main features of this printer are described below.

**Realizing High Resolution**

The newly developed ink technology provides high definition for photo, fine art, and proofing paper.

**New print head design**

Our new print heads are equipped with a 2.64 inch integrated precision core  $\mu$ TFP head with a staggered array, and we have adopted a resolution of 300 dpi for optimal printing.

**A variety of black and color inks**

As well as the three basic ink colors, the SC-P Series has gray ink and the SC-T Series has red ink.

Two types of black ink with the following features have also been installed.

**Two types of black ink to suit your printing purposes**

The printer automatically switches between two types of black ink to suit the paper type being used; Photo Black which realizes a smooth, professional finish on glossy paper and Matte Black which increases black optical density using matte paper.

**Notes on Usage and Storage**

**Installation space**

Make sure that you secure the following space, clear of any other objects, so that paper ejection and consumable replacement are not obstructed.

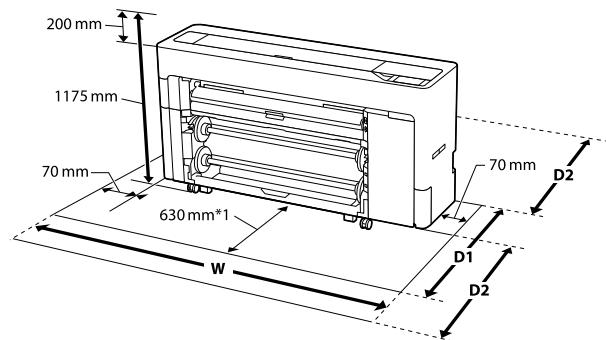

**SC-P8500DM Series/SC-P8500D Series/SC-T7700D Series/SC-P8500DL Series/SC-T7700DM Series/SC-T7700DL Series**

W	D1	D2
1988 mm	1129 mm	Secure up to 1600 mm plus the working space. The space required depends on the cut sheets/poster board being used.

**SC-T5700DM Series/SC-T5700D Series**

W	D1	D2
1785 mm	1129 mm	Secure up to 1600 mm plus the working space. The space required depends on the cut sheets/poster board being used.

## Introduction

### SC-P6500D Series/SC-T6500DE Series/SC-T3700D Series/SC-T3700DE Series

W	D1	D2
1505 mm	1129 mm	Secure up to 1600 mm plus the working space. The space required depends on the cut sheets/poster board being used.

### SC-P6500E Series/SC-T3700E Series

W	D1	D2
1505 mm	829 mm	Secure up to 1600 mm plus the working space. The space required depends on the cut sheets/poster board being used.

\*1 : For the SC-P6500E Series/SC-T3700E Series, secure a working space of 330 mm.

D1 : The space required when not using cut sheets/poster board.

D2 : The space required when using cut sheets/poster board. Secure up to 1600 mm front and back plus the working space.

## Notes when using the printer

Note the following points when using this printer to avoid breakdowns, malfunctions, and print quality decline.

- ❑ When using the printer, observe the operating temperature and humidity range described in the "Specifications Table".
    - 🔗 ["Specifications Table \(Except for the SC-P8500DL Series/SC-T7700DL Series\)" on page 240](#)
    - 🔗 ["Specifications Table \(SC-P8500DL Series/SC-T7700DL Series Only\)" on page 243](#)
- Even when the conditions above are met, you may not be able to print properly if the environmental conditions are not suitable for the paper. Be sure to use the printer in an environment where the

paper's requirements are met. For more details, see the documentation supplied with the paper. Also, when operating in dry areas, air conditioned environment, or under direct sunlight, maintain the appropriate humidity.

- ❑ Avoid using the printer in locations with heat sources or that are exposed to direct draughts from ventilators or air conditioners. Failure to observe this precaution could result in the print head nozzles drying and clogging.
- ❑ The print head may not be capped (i.e., may not move to the right-hand side) if an error occurs and the printer is turned off without first resolving the error. Capping is a function for automatically covering the print head with a cap (lid) to prevent the print head from drying out. In this case, turn on the power and wait a while until capping is performed automatically.
- ❑ When the power is on, do not remove the power plug or cut the power at the breaker. The print head may not be capped properly. In this case, turn on the power and wait a while until capping is performed automatically.
- ❑ Even when the printer is not in use, some ink will be consumed for all colors by head cleaning and other maintenance operations needed to keep the head in good condition.

## Notes when not using the printer

If you are not using it, note the following points when storing the printer. If it is not stored correctly, you may not be able to print properly the next time it is used.

- ❑ If you do not print for a long time, the print head nozzles may become clogged. We recommend that you print once a week to prevent the print head from clogging.
- ❑ The roller may leave an impression on paper that is left in the printer. This can also cause wavy or curled paper resulting in paper feeding problems or the print head could be scratched. Remove any paper when storing.

## Introduction

- ❑ Store the printer after confirming that the print head has been capped (the print head is positioned at the far right). If the print head is left uncapped for a long time, the print quality may decline.

**Note:**

*If the print head is not capped, turn the printer on, and then turn it off.*

- ❑ To prevent the accumulation of dust and other foreign matter in the printer, close all covers before placing it in storage.  
If the printer will not be used for an extended period, protect it with an anti-static cloth or other cover.  
The print head nozzles are very small, and they can become clogged easily if fine dust gets on the print head, and you may not be able to print properly.
- ❑ When turned on after an extended period of disuse, the printer may automatically perform head cleaning to ensure print quality.  
 ["Print Head Maintenance" on page 172](#)

## Notes when using the control panel

- ❑ Touch the panel with your finger. It will only react when you touch it with your finger.
- ❑ It may not react when operated with something other than a finger, when operated with wet fingers or gloved hands, or when operated when there is a protective sheet or sticker on the panel.
- ❑ Do not operate with sharp objects such as ballpoint pens or mechanical pencils. Doing so could damage the control panel.
- ❑ If the panel gets dirty, wipe it with a soft cloth. If the panel is particularly dirty, dampen the cloth with water containing a small amount of neutral detergent, firmly wring the cloth dry before using it to wipe the panel, and then finish by wiping with a soft, dry cloth. Never use volatile chemicals such as thinner, benzene, or alcohol. Doing so could damage the surface of the control panel.

- ❑ Do not use in an environment that is subject to sudden changes in temperature or humidity. Condensation may form inside the panel, causing a decline in performance.
- ❑ Some pixels on the screen may not light up or may light up constantly. Also, due to the characteristics of the liquid crystal display, uneven brightness may occur, but this is not a malfunction.

## Notes on handling ink cartridges (only for models with ink cartridges)

Note the following points when handling ink cartridges to maintain good print quality.

- ❑ The supplied ink cartridges and Maintenance Boxes are for use during the initial charging. Prepare replacement ink cartridges and Maintenance Boxes in advance.
- ❑ We recommend that ink cartridges be stored at room temperature out of direct sunlight and used before the expiry date printed on the packaging.
- ❑ To ensure good results, we recommend that all the ink in the cartridge be used within a year of installation.
- ❑ Ink cartridges that have been stored at low temperatures for an extended period should be allowed to return to room temperature over a period of four hours.
- ❑ Do not touch the IC chips on the ink cartridges. You may not be able to print properly.
- ❑ Install ink cartridges into all slots. You cannot print if any of the slots are empty.
- ❑ Do not leave the printer without ink cartridges installed. The ink in the printer will dry out and the printer will not function as expected. Leave ink cartridges in all slots even while you do not use the printer.
- ❑ The ink level and other data are stored in the IC chip, allowing cartridges to be used after being removed and replaced.

## Introduction

- ❑ To avoid getting dirt on the ink supply port, store the removed ink cartridge properly. The ink supply port has a valve in it so it does not need to be capped.
- ❑ Removed ink cartridges may have ink around the ink supply port, so be careful not to get any ink on the surrounding area when removing the cartridges.
- ❑ To maintain the quality of the print head, this printer stops printing before ink cartridges are completely expended.
- ❑ Although the ink cartridges may contain recycled materials, this does not affect printer function or performance.
- ❑ Do not dismantle or remodel ink cartridges. You may not be able to print properly.
- ❑ Do not drop or otherwise subject an ink cartridge to a strong impact. Ink may leak from the cartridge.

---

### Notes on handling the ink supply units (only for models with ink supply units)

- ❑ Store ink supply units at room temperature out of direct sunlight.
- ❑ To ensure print quality, we recommend using all of the ink before whichever of the following dates is earlier:
  - ❑ The recommended expiry date shown on the ink supply unit packaging
  - ❑ One year from the date the ink supply unit was installed
- ❑ Ink supply units that have been stored at low temperatures for an extended period should be allowed to return to room temperature over a period of four hours.
- ❑ The ink level and other data are stored in the IC chip, allowing ink supply units to be used after being removed and replaced.

- ❑ To avoid getting dirt on the ink supply port, store the removed ink supply unit properly. The ink supply port has a valve in it so it does not need to be capped.
- ❑ Removed ink supply units may have ink around the ink supply port, so be careful not to get any ink on the surrounding area when removing the ink supply units.
- ❑ Do not touch the ink supply unit IC chip. Doing so may prevent normal operation and printing.
- ❑ Do not drop or knock an ink supply unit against hard objects; otherwise, the ink may leak from the ink supply unit.
- ❑ Even when the printer is not in use, some ink will be consumed for all colors by head cleaning and other maintenance operations needed to keep the head in good condition.
- ❑ Although the ink supply units may contain recycled materials, this does not affect printer function or performance.
- ❑ Do not leave the printer without ink supply units installed. The ink in the printer will dry out and the printer will not function as expected. Leave ink supply units for all colors installed even when the printer is not in use.
- ❑ Install ink supply units for all colors. You cannot print unless all colors are installed.
- ❑ To maintain the quality of the head, this printer stops printing before ink supply units are completely expended.
- ❑ Do not dismantle or remodel ink supply units. You may not be able to print properly.

---

### Notes on handling paper

Note the following points when handling and storing the paper. If the paper is not in good condition, print quality may decline.

Check the documentation supplied with each paper.

## Introduction

### Notes on Handling

- ❑ Use Epson special media under normal room conditions (temperature: 15 to 25°C, humidity: 40 to 60%).
- ❑ Do not fold the paper or scratch the surface of the paper.
- ❑ Avoid touching the printable surface of the paper with your bare hands. Moisture and oils from your hands can affect print quality.
- ❑ Handle paper by the edges. We recommend wearing cotton gloves.
- ❑ Changes in temperature and humidity may cause paper to become wavy or curled. Check the following points.
  - ❑ Load the paper just before printing.
  - ❑ Do not use wavy or curled paper. For roll paper, cut off the wavy or curled parts and then load it again. For cut sheets, use new paper.
- ❑ Do not wet the paper.
- ❑ Do not throw away the paper packaging as you can use it for storing the paper.
- ❑ Avoid locations that are subject to direct sunlight, excessive heat, or humidity.
- ❑ Keep cut sheets in their original package after opening, and keep them in a flat place.
- ❑ Remove roll paper that is not in use from the printer. Rewind it correctly and then store it in the original packaging that came with the roll paper. If you leave the roll paper in the printer for a long time, its quality may decline.

### Notes on handling printed paper

To maintain long lasting, high quality print results, note the following points.

- ❑ Do not rub or scratch the printed surface. If they are rubbed or scratched, the ink may peel off.
- ❑ Do not touch the printed surface, as this may remove the ink.

- ❑ After printing, make sure the print outs are completely dry, and do not stack or fold the paper. Otherwise, the color may change where they touch (leaves a mark). These marks will disappear if they are separated immediately and dried; however, they will remain if not separated.
- ❑ If you put the print outs in an album before they are completely dry, they may be blurred.
- ❑ Do not use a dryer to dry the print outs.
- ❑ Avoid direct sunlight.
- ❑ Prevent color distortion while displaying or storing the print outs by following the instructions in the paper's documentation.

#### Note:

*Typically, print outs and photos fade over time (color distortion) due to the effects of light and various constituents in the air. This also applies to Epson special media. However, with the correct storage method, the degree of color distortion can be minimized.*

- ❑ *See the documentation supplied with Epson special media for detailed information on handling the paper after printing.*
- ❑ *The colors of photos, posters, and other printed materials appear different under different lighting conditions (light sources<sup>\*</sup>). The colors of print outs from this printer may also appear different under different light sources.*  
<sup>\*</sup> *Light sources include sunlight, fluorescent light, incandescent light, and other types.*

## Saving Power

The printer enters sleep mode or turns off automatically if no operations are performed for a set period. You can adjust the time before power management is applied.

Any increase will affect the product's energy efficiency. Please consider the environment before making any changes.

### Sleep mode

The printer enters sleep mode when there are no errors, no print jobs being received, and no control panel or other operations performed. When the printer enters sleep mode, the control panel's screen turns off and the internal motors and other parts switch off to consume less power.

## Introduction

Sleep mode is cleared if a print job is received or a button on the control panel is pressed.

You can set the time before entering sleep mode from 1 to 120 minutes. At default settings, the printer enters sleep mode if no operations are performed for 15 minutes. You can change the **Sleep Timer** in “General Settings”.

 [“General Settings” on page 147](#)

**Note:**

*When the printer enters sleep mode, the control panel's screen goes blank as if the power has been turned off, but the power light remains on.*

### Power Off Timer

The printer is equipped with a Power Off Timer option that automatically turns the printer off if no errors occur, no print jobs are received, and no control panel or other operations are performed for a set period of time. You can set the time until the printer automatically turns off from 30 minutes to 12 hours.

The factory default setting is **Off**. You can perform **Power Off Timer** from the “General Settings” menu.

 [“General Settings” on page 147](#)

## Introducing the Software

# Introducing the Software

## Supplied Software

The following table shows the software supplied.



Windows versions are provided on the software disc supplied. If you are using a Mac or a computer without a disc-drive, you can download and install the software from the following link: <https://epson.sn>.

For details on the various software, see the online help of each software or the *Administrator's Guide* (online manual).



**Note:**

Convenient software compatible with this printer is introduced on the Epson website. Please check the information from the following link.

<https://www.epson.com>

Software Name	Function
Printer Driver	Install the printer driver to take full advantage of the functionality of this printer when printing.
PS printer driver (Except for models without the Adobe PS3 Expansion Unit)	Use this printer driver when printing using the Adobe® PostScript® 3™ expansion unit. The Adobe® PostScript® 3™ expansion unit is included on the CD supplied.
PS Folder (Except for models without the Adobe PS3 Expansion Unit)	This software allows you to print without using any other applications by simply dragging and dropping the corresponding file onto the PS Folder icon. The Adobe® PostScript® 3™ expansion unit is included on the CD supplied.
Epson Software Updater	Software to check whether there is any software update information and then notify you and install the software if an update is available. It allows you to update the firmware and already installed software of the printer.  <a href="#">"Updating Software or Installing Additional Software" on page 37</a>
LFP Print Plug-In for Office (Windows only)	Plug-in software for Microsoft Office applications (Word, Excel, and PowerPoint). Installing this plug-in displays ribbon items in Office applications that give quick access to horizontal and vertical banner printing and enlarged printing. It can be installed by selecting it in the Install more screen when installing the software. You can also install it later with Epson Software Updater. The supported Microsoft versions are shown below. Office 2003/Office 2007/Office 2010/Office 2013/Office 2016/Office 2019
Epson Edge Dashboard*	Convenient software for administrating multiple printers. This enables confirmation in a list of the status of printers registered for monitoring. You can also easily copy custom paper settings on one printer to multiple other printers.  <a href="#">"Starting Procedure" on page 36</a>  <a href="#">"Closing Procedure" on page 36</a>

## Introducing the Software

Software Name	Function
Epson Media Installer*	<p>This is a tool for adding paper information to the printer or printer driver.</p> <p>If you are using Windows, you can start this tool from the printer driver.</p> <p>If you are using Mac, you can start this tool from /Applications/Epson Software/Epson Utilities/Epson Media Installer.app.</p> <p> <a href="#">"Using Epson Media Installer" on page 28</a></p>
EpsonNet Config SE	<p>Software to configure the initial settings of the network or change the settings of the network in bulk when installing or relocating Epson printers and scanners.</p> <p>EpsonNet Config SE is not installed automatically. Download it from the Epson website and then install it if necessary.</p> <p><a href="https://www.epson.com">https://www.epson.com</a></p> <p>For Windows, you can install the software from the following folder on the supplied software disc.</p> <p>\\Network\EpsonNetConfig</p> <p> <i>Administrator's Guide</i></p>
Scanner Driver (Epson Scan 2) (SC-P8500DM Series/ SC-T7700DM Series/SC-T5700DM Series Only)	<p>Epson Scan 2 is the driver that controls the scanner. Make sure you install this if you want to use the scanner.</p>
Document Capture Pro* or Document Capture* (SC-P8500DM Series/ SC-T7700DM Series/SC-T5700DM Series Only)	<p>Document Capture Pro or Document Capture is software that allows you to easily and efficiently digitize originals such as documents and spreadsheets to suit your needs. Make sure you install this if you want to save scanned data to your computer.</p>

\*Download software from the Internet, and install. Connect your computer to the Internet and install the software.

## Pre-installed Software

This software is pre-installed on the printer. You can start it from a web browser via a network.

Software Name	Function
Web Config	<p>You can configure the network security settings from Web Config. It also provides an e-mail notification function to inform you when errors and so on occur in the printer.</p> <p> <a href="#">"Using Web Config" on page 35</a></p>

## Introducing the Software

# Using Epson Media Installer

This section provides a summary of the Epson Media Installer features and basic operations.

Epson Media Installer allows you to add paper information from the Internet. You can also edit the paper information you have added.

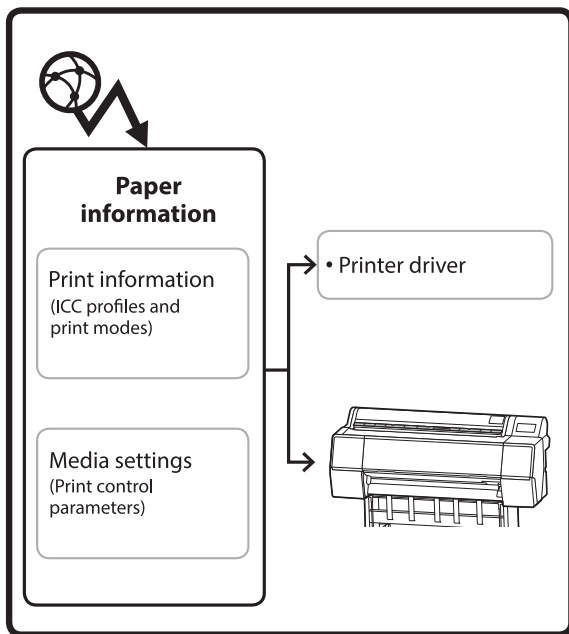

Paper information, including ICC profiles, print modes, and print control parameters, is downloaded from servers. Downloaded paper information is saved in the printer driver or the printer.

## Starting Procedure

**Note:**

You need to download Epson Media Installer. See your printer's support page for details on installation.

See the following for more information.

[“Introducing the Software” on page 26](#)

Use one of the following methods to start Epson Media Installer.

### For Windows

Start Epson Media Installer.  
Start/Epson Software/Epson Media Installer

### For Mac

Start Epson Media Installer.  
/Applications/Epson Software/Epson Utilities/Epson Media Installer.app

### Printer driver (Windows)

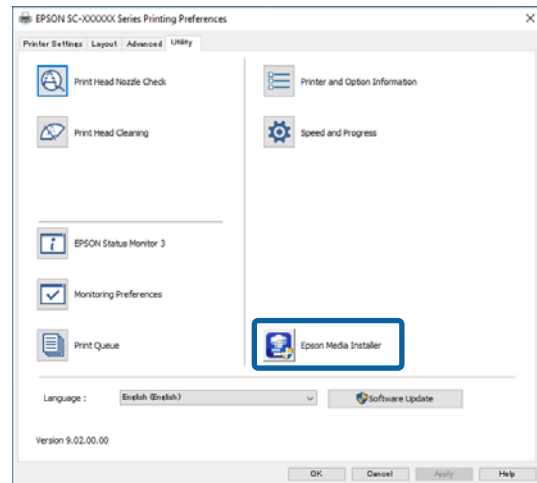

### Epson Edge Dashboard



## Introducing the Software

### Configuration of main screen

One of the following screens is displayed when you start Epson Media Installer. Click the screen name at the top of the screen to switch screens.

- Media Management screen
- Media Download screen

The configuration and functions of the screens are shown below.

### Media Management screen

Displays paper information stored on the selected printer.

However, paper information set in **Custom Paper Setting** on the printer's control panel is not displayed.

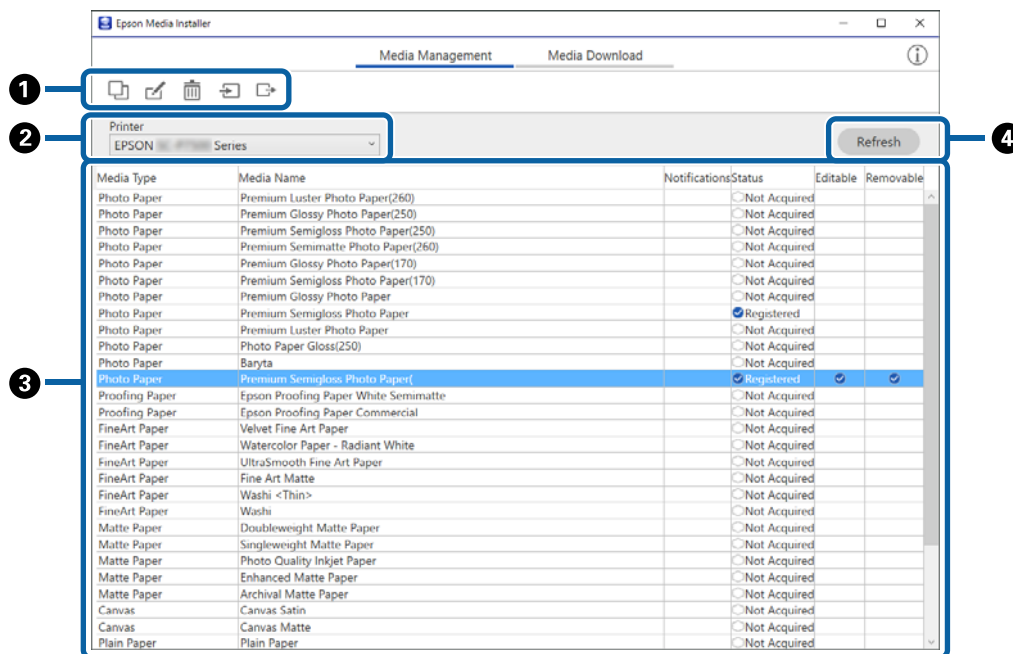

	Names of parts	Function
1	Media operation area	<p>You can perform the following operations on the paper information selected in the media list (3).</p> <ul style="list-style-type: none"> <li> (Copy Media): Makes a copy of the selected paper information and saves it in the printer or the printer driver.</li> <li> (Edit): Changes the settings for the selected paper information. If the settings can be changed, the Edit Media Settings screen is displayed. <a href="#">"Edit Media Settings Screen Configuration" on page 32</a></li> <li> (Delete): Deletes the selected paper information from the printer or the printer driver.</li> <li> (Import from File): Imports a paper information file. You can only import one file at a time.</li> <li> (Export to File): Exports selected paper information to a file. You can only export one file at a time.</li> </ul>

## Introducing the Software

	Names of parts	Function
2	Printer	Select the printer for which you want to display the paper information.
3	Media List	<p>Displays paper information stored on the printer selected in Printer (2) as a list.</p> <p>The following explains the display contents of each column.</p> <ul style="list-style-type: none"> <li><input type="checkbox"/> Media Type Displays the paper information for each media type. The order in which media types are displayed is the same as on the printer's control panel.</li> <li><input type="checkbox"/> Media Name Paper information copied using <input type="checkbox"/> (Copy Media) has the word "(Copy)" displayed at the end of the name.</li> <li><input type="checkbox"/> Notifications When additional information is available, <b>i</b> is displayed. Click it to view the information.</li> <li><input type="checkbox"/> Status                             <ul style="list-style-type: none"> <li><input checked="" type="checkbox"/> Registered: Paper information that has been downloaded to Epson Media Installer, and saved to the printer or the printer driver.</li> <li><input type="checkbox"/> Not Acquired: Paper information that has not been downloaded to Epson Media Installer, but has been saved to the printer or the printer driver. You can print on Epson Special Media even if the status is <b>Not Acquired</b>.</li> </ul> </li> <li><input type="checkbox"/> Editable <input checked="" type="checkbox"/> is displayed for paper information with settings that can be changed.</li> <li><input type="checkbox"/> Removable <input checked="" type="checkbox"/> is displayed for paper information that can be deleted.</li> </ul>
4	Refresh button	Click this if paper information you added previously is not displayed in the printer driver.

## Media Download screen

Download paper information from the server and register it to your printer, printer driver, and so on.

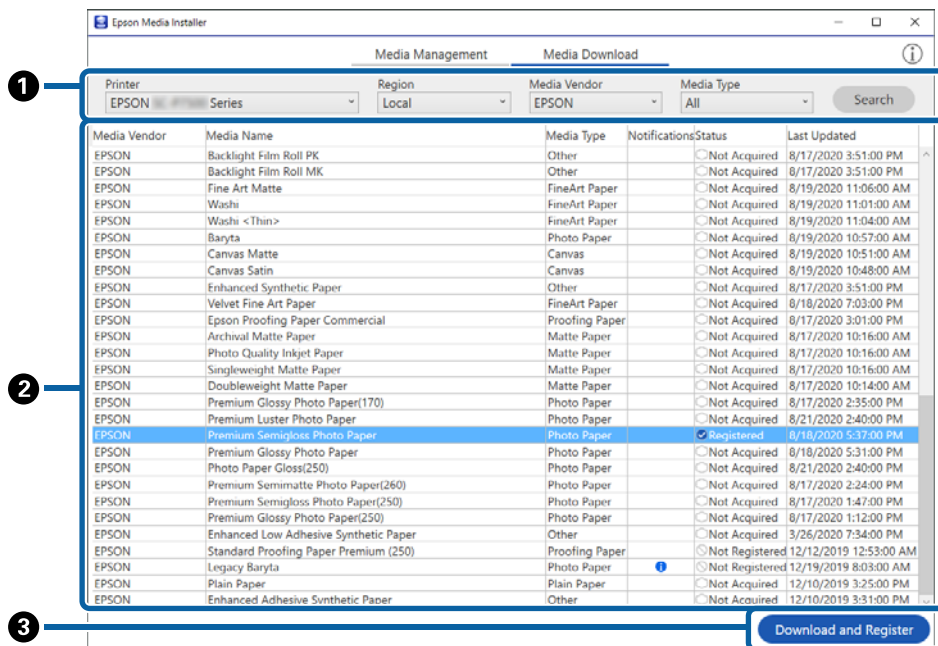

## Introducing the Software

	Names of parts	Function
①	Search conditions area	To narrow down the paper information displayed in the media list (②), specify the conditions and click <b>Search</b> .
②	Media List	<p>Paper information that meets the search conditions specified in the search conditions area (①) is displayed.</p> <p>The following explains the display contents of <b>Notifications</b> and <b>Status</b>.</p> <ul style="list-style-type: none"> <li><input type="checkbox"/> <b>Notifications</b> When additional information is available,  is displayed. Click it to view the information.</li> <li><input type="checkbox"/> <b>Status</b> <ul style="list-style-type: none"> <li><input checked="" type="checkbox"/> <b>Registered:</b> Paper information that has been downloaded to Epson Media Installer, and saved to the printer or the printer driver.</li> <li><input checked="" type="checkbox"/> <b>Update Available:</b> Paper information on the server has been updated. When you download the paper information again, the latest paper information is saved to the printer or the printer driver.</li> <li><input type="checkbox"/> <b>Not Registered:</b> Paper information has not been saved to the printer or the printer driver.</li> <li><input type="checkbox"/> <b>Not Acquired:</b> Paper information has not been downloaded to Epson Media Installer.</li> </ul> </li> </ul>
③	Download and Register button	Download the selected paper information from the server and save it to the printer or the printer driver.

## Introducing the Software

# Edit Media Settings Screen Configuration

Change the paper information settings on the Edit Media Settings screen.

The following are the main setting items.

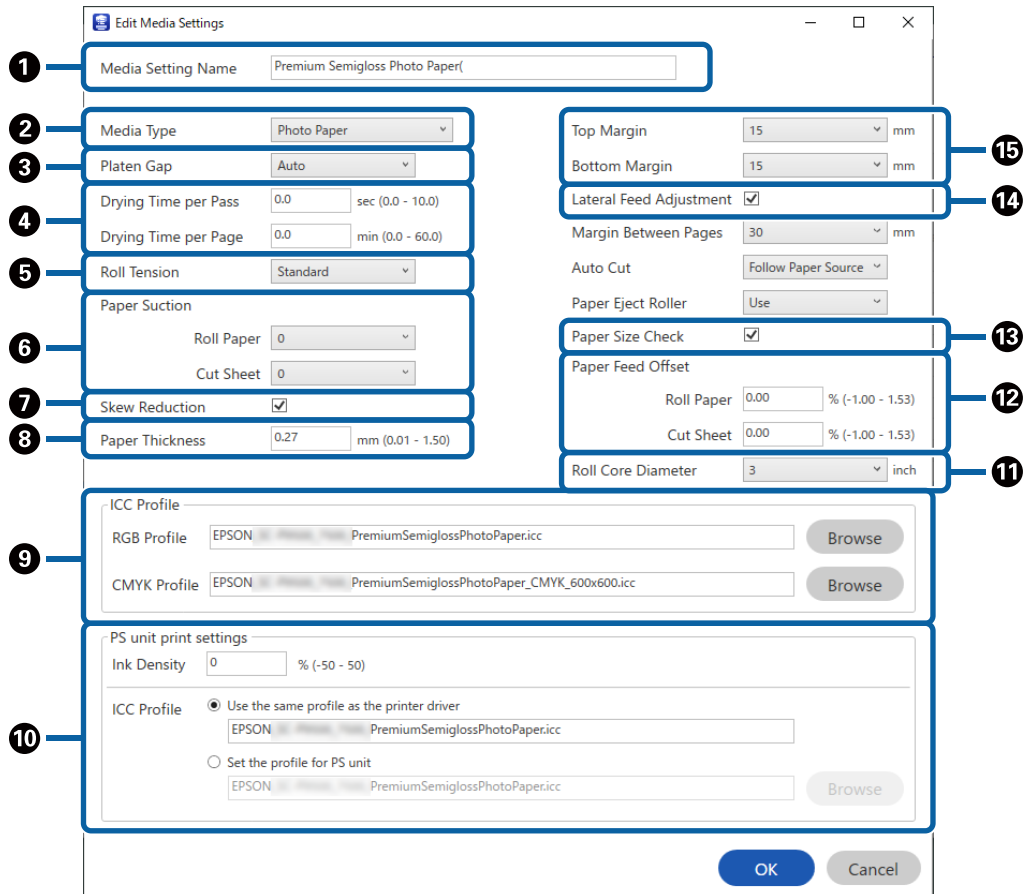

Item	Function	
1	Media Setting Name	You can change the media name to any name you want.
2	Media Type	You can change the type of paper information. This change is reflected in the printer driver's display and the printer's control panel.
3	Platen Gap	Select a wider setting if print results are scratched or smudged.
4	Drying Time	You can set the drying time for each print head movement (pass) or the drying time for each page.
5	Roll Tension	Adjust this when paper gets wrinkled during printing.
6	Paper Suction	Thin or soft paper may not be fed correctly. If this occurs, reduce the setting value.
7	Skew Reduction	Select this to reduce paper skew while feeding.
8	Paper Thickness	Set the thickness of the paper.

## Introducing the Software

	Item	Function
9	ICC Profile	<p>Click <b>Browse</b> to change the ICC profile. You can set <b>RGB Profile</b> and <b>CMYK Profile</b>.</p> <ul style="list-style-type: none"> <li><input type="checkbox"/> When printing using the printer driver, set <b>RGB Profile</b>.</li> <li><input type="checkbox"/> When printing using a software RIP, set the color mode profile that is supported by your RIP to either <b>RGB Profile</b> or <b>CMYK Profile</b>.</li> </ul>
10	PS unit print settings	<p>Displayed when the Adobe® PostScript® 3™ expansion unit is installed. Sets the print settings when using the Adobe® PostScript® 3™ expansion unit.</p>
	Ink Density	<p>Set the ink density for printing using the PS Folder. When printing from the Adobe® PostScript® 3™ expansion unit without using the PS Folder, the ink density set in the PS printer driver is applied.</p> <p>See the following for details on the PS Folder.   "Adobe® PostScript® 3™ Expansion Unit User's Guide"</p>
	ICC Profile	<p>Set the ICC profile when printing from the Adobe® PostScript® 3™ extension unit. Select one of the following.</p> <ul style="list-style-type: none"> <li><input type="checkbox"/> <b>Use the same profile as the printer driver</b>            The profile set as the <b>RGB Profile</b> for the ICC Profile (9) is used as the ICC profile when printing from the Adobe® PostScript® 3™ expansion unit. This cannot be selected if the <b>RGB Profile</b> is blank, so set the <b>RGB Profile</b> first.</li> <li><input type="checkbox"/> <b>Set the profile for PS unit</b>            Select this when the CMYK profile is used as the ICC profile when printing from the Adobe® PostScript® 3™ expansion unit. Click <b>Browse</b> to set the profile.</li> </ul>
11	Roll Core Diameter	Set the paper core size for the roll paper being loaded.
12	Paper Feed Offset	<p>Optimizes the paper feed when printing. By adjusting the gap between the data size and the print size, you can reduce the chance of banding (horizontal banding) or uneven colors.</p> <p>Example of entering settings            When printing at a data size of 100 mm and a print size of 101 mm, the offset is 1.0%. Therefore, you would enter a value of -1.0%.</p>
13	Paper Size Check	Select this to automatically detect the width of the loaded paper.
14	Lateral Feed Adjustment	Select this to correct differences in the left or right of the paper feed. The printer does not support this function.
15	Margins	If the margin at the leading edge of the paper is small, colors may be uneven depending on the paper and printing environment. If this occurs, print a larger margin at the leading edge of the paper.

See the following for details on making settings other than the above.

 "Paper Setting" on page 138

## Introducing the Software

### Adding Paper Information

See the following for details on how to add paper information to the printer or printer driver using Epson Media Installer.

[“Adding Paper Information” on page 59](#)

### Editing Paper Information

See the following for details on how to edit paper information that has been added.

[“Editing Paper Information” on page 60](#)

### Sharing Paper Information with Multiple Computers

This section explains how to share paper information that was added/edited using Epson Media Installer between computers when multiple computers are connected to one printer.

For example, you can connect computer [A] and computer [B] to one printer and then add/edit paper information in Epson Media Installer on computer [A]. In this case, the added/edited paper information is displayed in the Epson Media Installer on computer [B], but the added/edited paper information is not displayed in the printer driver on [B]. To display the added/edited paper information in the printer driver for [B], share the paper information between the computers.

### Sharing added paper information

**1** Start Epson Media Installer on one of the computers connected to the same printer and add the paper information.

[“Adding Paper Information” on page 59](#)

**2** Start Epson Media Installer on a different computer than in step 1, and then click **Media Download**.

**3** Select the same paper information that you added in step 1, and then click **Download and Register**.

Paper information is added to the paper type for the printer driver on this computer.

When three or more computers are connected to one printer, repeat steps 2 to 3 for each computer.

### Sharing edited paper information

**1** Start Epson Media Installer on one of the computers connected to the same printer and edit the paper information.

[“Editing Paper Information” on page 60](#)

**2** Click **Media Management**, select the paper information you edited in step 1, and then click **(Export)**.

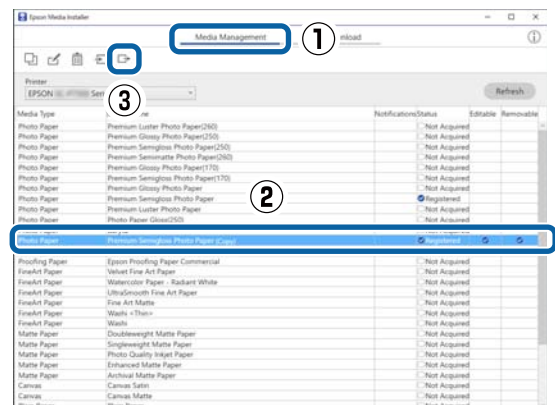

**3** Select the save location, and then save the file. The saved file has the extension .emy.

**4** Start Epson Media Installer on a different computer than in steps 1 to 3, and then click **Media Management**.

## Introducing the Software

- Click  (Import).  
The **Open** screen is displayed.

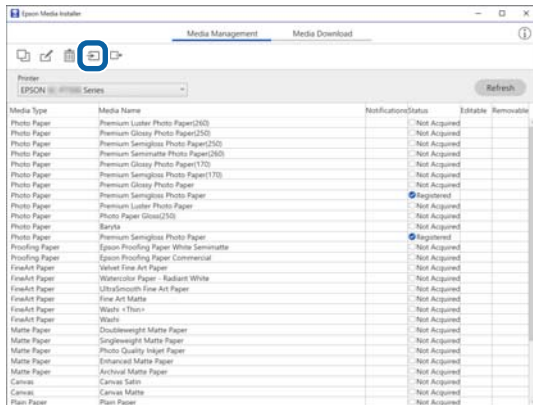

- Select the file you saved in step 3, and then click **Open**.  
The file extension is (.emy).

If there are no files displayed with the extension .emy, select **EMY File(\*.emy)** from the drop-down menu to the right of the **File Name**.

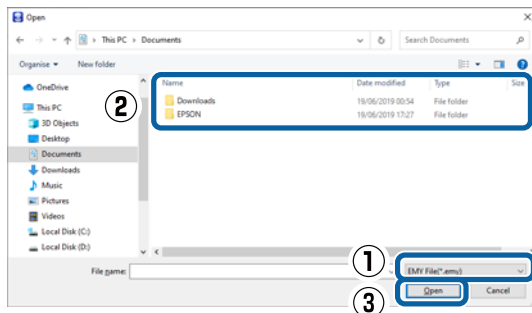

Paper information is added to the paper type for the printer driver on this computer.



When three or more computers are connected to one printer, repeat steps 4 to 6 for each computer.

## Using Web Config

Provides an overview of starting the software and the functions provided.

## Starting Procedure

Start the software from a web browser on a computer or smart device that is connected to the same network as the printer.

- Check the IP address of the printer.  
Press   on the Home screen, select the connected network, and check the IP address.

### Note:

The IP address can also be checked by printing a network connection check report. A report can be printed by touching the following in order from the Home screen.

**Menu - General Settings - Network Settings - Connection Check**

- Start a Web browser on a computer or smart device connected to the printer via the network.

- Enter the IP address of the printer in the address bar of the Web browser and press the **Enter** or **Return** key.

Format:

IPv4: http://IP address of printer/

IPv6: http://[IP address of printer]/

Example:

IPv4: http://192.168.100.201/

IPv6: http://[2001:db8::1000:1]/

### Note:

The initial value for the administrator user name is blank (nothing entered), and the initial value for the administrator password is the product's serial number. Check the product's serial number on the label on the printer.

## Closing Procedure

Close the Web browser.

## Introducing the Software

### Function Summary

This section introduces the main functions of Web Config. See the *Administrator's Guide* for more details.



### Main Functions

- ❑ Check the printer's status, such as the remaining amount of ink.
- ❑ Check and update the printer's firmware version.
- ❑ Configure the printer's network settings and advanced security settings, such as SSL/TLS communication, IPsec/IP filtering, and IEEE802.1X, which cannot be configured with the printer alone.
- ❑ Edit the custom paper settings and export and import the settings.  
The custom paper settings registered in **Menu - General Settings - Printer Settings - Custom Paper Setting** of the printer can be changed as well as exported to a file and then imported (registered) to another printer. This is convenient when you install multiple printers and want to use common custom paper settings for them.
- ❑ You can print by simply selecting the file you want to print, and then uploading it to the printer.

## Using Epson Edge Dashboard

### Starting Procedure

Epson Edge Dashboard is a Web application that resides on your computer. When you start your computer, Epson Edge Dashboard starts automatically and is always running.

1

Display the screen using the following method.

#### Windows

Click the **Epson Edge Dashboard** icon on the desktop taskbar, and then select **Show Epson Edge Dashboard**.



You can also click **Start - All Programs (or Programs) - Epson Software - Epson Edge Dashboard**.

#### Mac

Click the **Epson Edge Dashboard** icon on the menu bar of the desktop, and then select **Show Epson Edge Dashboard**.



2

The Epson Edge Dashboard screen is displayed.

For details, see the Epson Edge Dashboard help.

### Closing Procedure

Close the web browser and close the Epson Edge Dashboard screen display. Since Epson Edge Dashboard is a resident software, it does not stop running.

## Introducing the Software

# Using EPSON Software Updater

## Checking software update availability

- 1 Check the following status.
  - The computer is connected to the Internet.
  - The printer and the computer can communicate.

- 2 Start EPSON Software Updater.

### Windows 8.1/Windows 8

Enter the software name in the search charm, and select the icon displayed.

### Windows 10/Windows 11

Click the start button, and then click **All Programs - Epson Software - EPSON Software Updater**.

### Mac

Click **Go - Applications - Epson Software - EPSON Software Updater**.

#### Note:

*In Windows, you can also start by clicking the printer icon on the desktop toolbar and selecting **Software Update**.*

- 3 Update the software and manuals.  
Follow the on-screen instructions to continue.

#### Important:

*Do not turn off the computer or printer while updating.*

#### Note:

*Software that is not displayed in the list cannot be updated by EPSON Software Updater. Check the latest versions of software on the Epson website.*

<https://www.epson.com>

## Receiving update notifications

- 1 Start EPSON Software Updater.
- 2 Click **Auto upload settings**.
- 3 Select the interval to perform the update check in the **Interval to Check** field of the printer and then click **OK**.

## Updating Software or Installing Additional Software

When you install the software during setup as described in the *Setup Guide*, Epson Software Updater is installed. Epson Software Updater allows you to update the firmware and already installed software of the printer, and install additional software compatible with the printer.

#### Note:

*The software is updated as needed for greater convenience and more robust functionality. We recommend setting to receive update notifications with Epson Software Updater and updating the software as soon as possible when there is a notification.*

## Checking software update availability

- 1 Check the following status.
  - The computer is connected to the Internet.
  - The printer and the computer can communicate.

- 2 Start Epson Software Updater.
  - Windows  
Display the list of all the programs and then click Epson Software Updater in the Epson Software folder.

## Introducing the Software

**Note:**

- ❑ If you press the Windows key (key with Windows logo mark) on the keyboard and then type the software name in the search box of the displayed window, the software appears immediately.
- ❑ The software can also be started by clicking the printer icon on the Taskbar of the desktop and then selecting **Software Update**.

- ❑ Mac  
Click **Go - Applications - Epson Software - EPSON Software Updater**.

- 3** Update the software and manuals.  
Follow the on-screen instructions to continue.

**! Important:**

Do not turn off the computer or printer while updating.

**Note:**

Software that is not displayed in the list cannot be updated by Epson Software Updater. Check the latest versions of software on the Epson website.

Also, if you are using Windows Server OS, you cannot use Epson Software Updater to install the software. Download the software from the Epson website.

<https://www.epson.com>

## Receiving update notifications

### Windows

- 1** Start Epson Software Updater.
- 2** Click **Auto upload settings**.
- 3** Select the interval to perform the update check in the **Interval to Check** field of the printer and then click **OK**.

### Mac

The software is set by default to check and notify whether there are updates every 30 days.

## Uninstalling Software

### Windows

**! Important:**

- ❑ You must log in as an Administrator.
- ❑ Enter the administrator password when prompted and then proceed with the remainder of the operation.

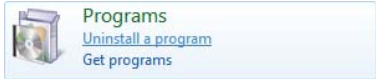
- 1** Turn off the printer, and unplug the interface cable.
- 2** Close all applications running on your computer.
- 3** From **Control Panel**, click **Programs - Uninstall a program**.  

- 4** Select the software you want to remove and then click **Uninstall/Change** (or **Change/Remove** / **Add/Remove**).

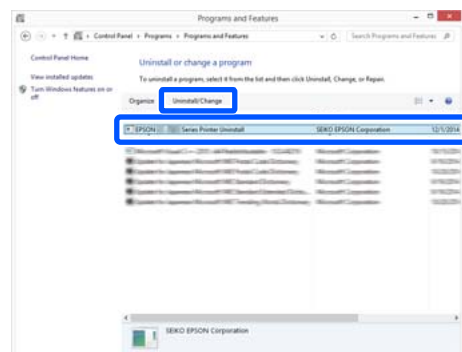
You can remove the printer driver and EPSON Status Monitor 3 by selecting **EPSON SC-XXXXX Printer Uninstall**.



## Introducing the Software

- 5** Select the target printer icon, and then click **OK**.



- 6** Follow the on-screen instructions to continue.  
When the delete confirmation message appears, click **Yes**.

Restart the computer if you are reinstalling the printer driver.

---

## Mac

When reinstalling or upgrading the printer driver or other software, follow the steps below to uninstall the target software first.

### Printer Driver

Use the Uninstaller.

### Downloading the Uninstaller

Download the “Uninstaller” from the Epson website.

<https://www.epson.com>

### Procedure

After downloading the “Uninstaller”, follow the instructions on the Epson website.

### Other Software

Drag and drop the folder with the software name from the **Applications** folder into **Trash** to delete.

## Changing the Network Connection Methods

# Changing the Network Connection Methods

The printer can connect to a wired LAN or a wireless LAN. Furthermore, it also supports Wi-Fi Direct (Simple AP) which allows a smart device or other device to directly connect wirelessly with the printer even when there is no wired LAN or wireless LAN environment.

The printer cannot connect to a wired LAN and wireless LAN at the same time. A Wi-Fi Direct connection is possible regardless of whether or not the printer is connected to a network.

Wireless LAN may not be supported depending on the specifications and destination. In this case, use a wired LAN.

This section describes the procedures to use to switch the connection method.

**Note:**

See the *Administrator's Guide (online manual)* for details on the network settings.

## Switching to Wired LAN

- 1 Press   on the Home screen.

**Note:**

The shape and color of the icon differ depending on the connection status.

 ["Home screen operations" on page 18](#)

- 2 Press **Description**.
- 3 Press **Wired LAN Connection Method**.
- 4 The process to disable the wireless LAN connection with the access point starts. Wait until **The Wi-Fi connection is disabled**. is displayed.

- 5 Connect your router and the printer with a LAN cable.

See the following for the location of the printer's LAN port.

 ["Back" on page 14](#)

## Switching to Wireless LAN

The SSID (network name) and password of the access point to which the printer is to be connected are required. Confirm them in advance. The printer can be connected to a wireless LAN while the LAN cable is still connected.

**Note:**

If your access point supports WPS (Wi-Fi Protected Setup), the printer can be connected using **Push Button Setup(WPS)** or **PIN Code Setup(WPS)** without using an SSID and password.

- 1 Press   on the Home screen.

**Note:**

The shape and color of the icon differ depending on the connection status.

 ["Home screen operations" on page 18](#)

- 2 Press **Router**.
- 3 Press **Start Setup**.  
Details of the wired LAN connection status are displayed.
- 4 Press **Change to Wi-Fi connection.**, check the displayed message, and then press **Yes**.
- 5 Press **Wi-Fi Setup Wizard**.
- 6 Select the desired SSID.  
If the desired SSID is not displayed, press **Search Again** to update the list. If it is still not displayed, press **Enter Manually** and directly enter the SSID.

## Changing the Network Connection Methods

**7** Press **Enter Password** and enter the password.

**Note:**

- Differentiate between uppercase and lowercase when entering the password.
- If the SSID was entered directly, set **Password** to **Available** before entering the password.

**8** When input is finished, press **OK**.

**9** Check the settings and then press **Start Setup**.

**10** Press **OK** to finish the procedure.

If the connection fails, select **Print Check Report** to print a network connection check report. You can check the action to take in the report.

**11** Close the Network Connection Settings screen.

## Directly Connecting Wirelessly (Wi-Fi Direct)

A direct connection with the printer can be established temporarily when, for example, the printer is not connected to a network or you do not have permission to log on to the network.

Wi-Fi Direct is disabled by default. The following describes the procedure from enabling Wi-Fi Direct to connecting.

**Note:**

The printer can connect with up to four smart devices or computers at the same time. If you want to connect another device when there are already four devices connected, disconnect the connection to the printer from a device that is already connected.

**1** Press   on the Home screen.

**Note:**

The shape and color of the icon differ depending on the connection status.

 ["Home screen operations" on page 18](#)

**2** Press **Wi-Fi Direct**.

When Wi-Fi Direct is already enabled, the network (SSID), password, number of connected devices, and so on are displayed. Go to step 5.

**Note:**

If a part of the displayed network (SSID) or device name, and so on cannot be seen because it is cut off at the right edge of the screen, press the corresponding item to display the entire setting value.

**3** Press **Start Setup**.

**4** Press **Start Setup**.

Wi-Fi Direct is enabled, and the network (SSID) and password are displayed.

**5** Open the Wi-Fi setting screen on the device you want to connect with the printer, select the SSID displayed on the screen of the printer, and enter the password just as it is displayed on the screen.

**6** When a connection is established, press **Close** to finish the procedure.

**7** Press **Close** on the screen of the printer to close the network connection settings screen.

When the printer driver is installed on the connected device, you can print using the printer driver.

**Note:**

When you turn off the power of the printer, the connections with connected devices are all disconnected. To reconnect after turning the printer back on, perform the procedure again from step 1.

## Basic Operations

# Basic Operations

## Notes on Loading the Paper



### Caution:

Do not rub the edges of the paper with your hands. The edges of the paper are thin and sharp and could cause an injury.

### Do not load roll paper with the right and left edges uneven

Loading roll paper with the right and left edges uneven may cause paper feeding problems or paper meandering may occur during printing. Rewind the paper to make the edges even before using roll paper or use roll paper with no problem.

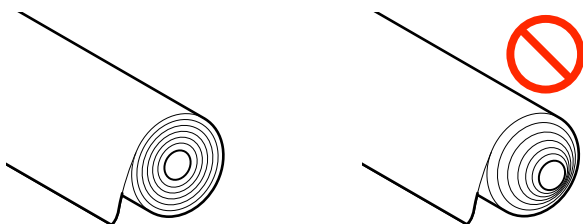

### Do not load curled paper

Loading curled paper may cause paper jams or soiled prints. Flatten the paper before use by bending it in the opposite way or use paper with no problem.

### Unsupported paper

Do not use paper that is wavy, torn, cut, folded, too thick, too thin, has a sticker affixed, etc. Doing so may cause paper jams or soiled prints. See the following for paper supported by the printer.

 “Epson Special Media Table” on page 220

 “Supported Commercially Available Paper” on page 229

## Loading and Removing the Roll Paper

### Loading Roll 1/Roll paper

1

Turn on the printer.

2

Set the paper support to the position shown in the illustration.

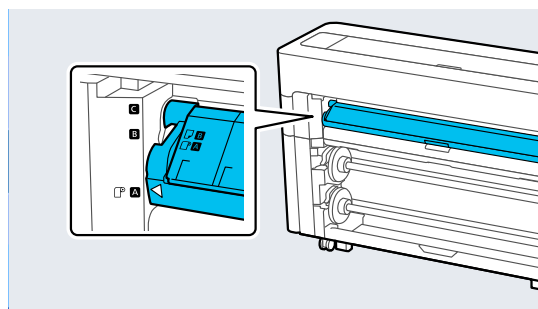
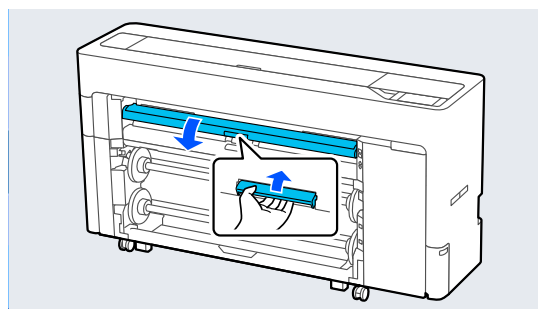

### Note:

Close the flap if it is open.

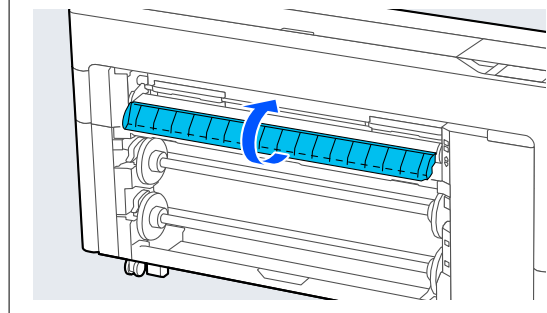

## Basic Operations

- 3** Raise the spindle lock lever.

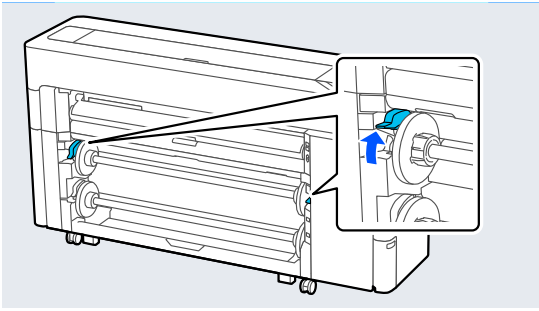

- 4** Remove the spindle.

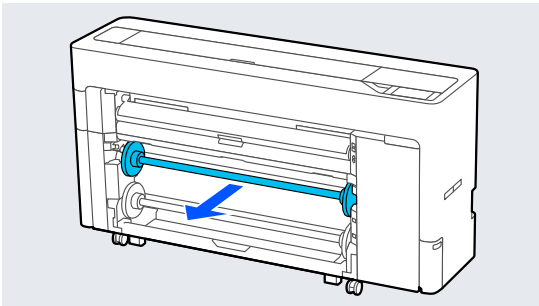

- 5** Remove the transparent media edge guide from the spindle.

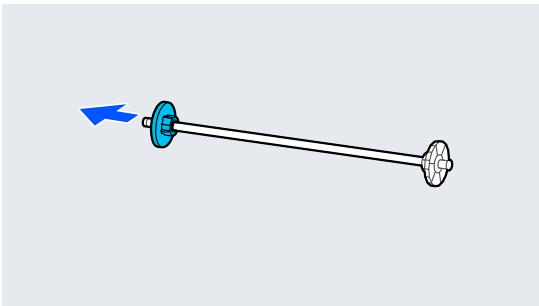

- 6** Attach or remove the core adapter according to the core size of the roll paper to be loaded.

### 2-inch core

Remove the core adapters from the media edge guides on both sides.

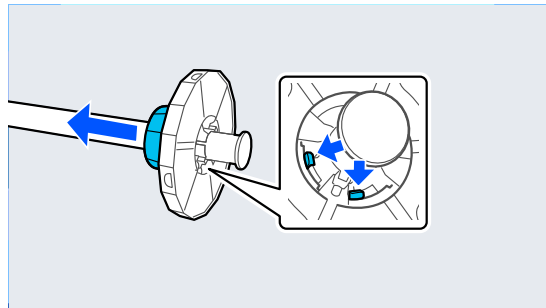
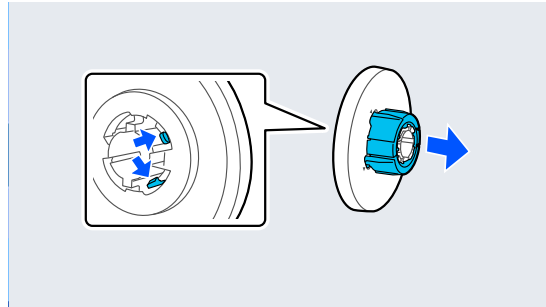

### 3-inch core

Attach the core adapters to the media edge guides on both sides.

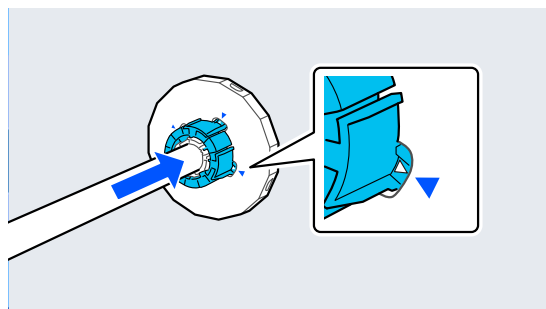
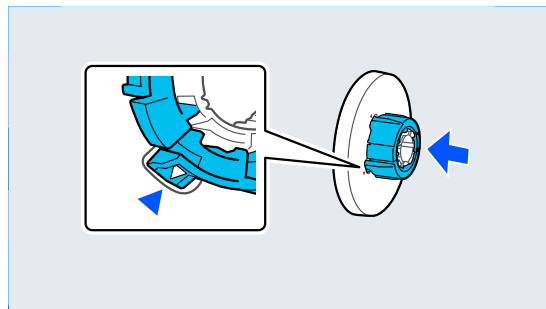

## Basic Operations

- 7** Insert the spindle with the roll paper facing the direction shown in the illustration.

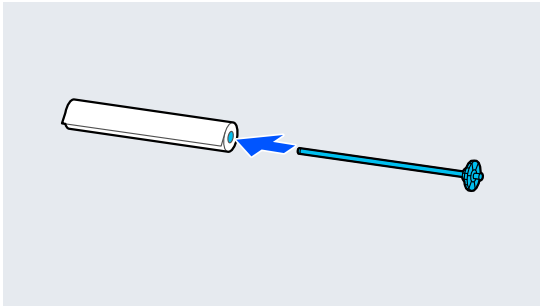

- 8** Attach the transparent media edge guide to the spindle.

Attach them so that there are no gaps between the roll paper and the media edge guides.

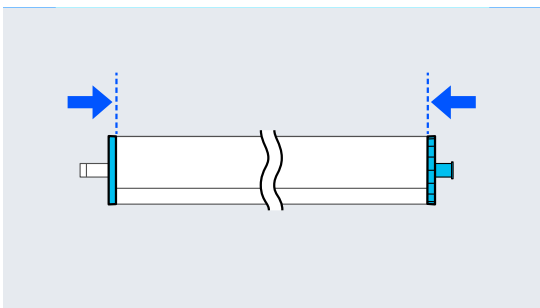
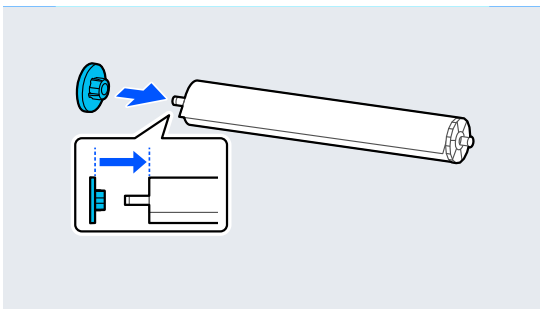

- 9** Place the spindle into the grooves with the black media edge guide on the right.

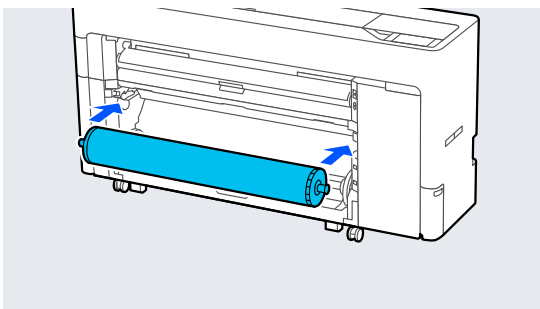

- 10** Lower the spindle lock lever.

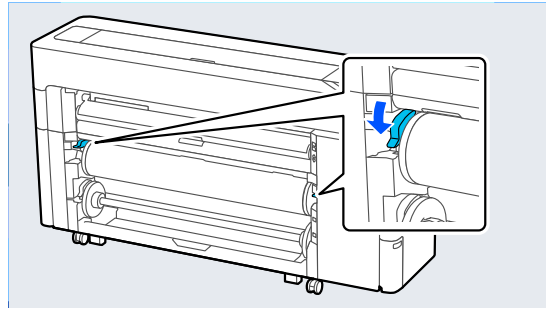

- 11** Pull out the paper basket.

You can stack one sheet at a time in the paper basket. When printing multiple sheets, remove the ejected paper so that print outs do not accumulate in the basket.

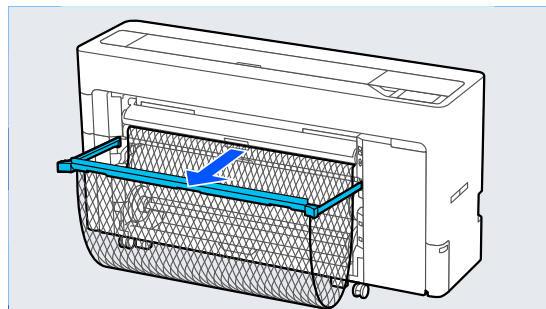

- 12** Make the paper settings.

 [“Setting Loaded Paper” on page 56](#)

## Removing Roll 1/Roll paper

This section describes how to remove the roll paper from the printer after printing.

If the roll paper is not cut, select **Paper Setting - Roll 1** or **Roll - Feed/Cut Paper** and adjust the cutting position to cut the roll paper.

- 1** If the paper basket is pulled out, remove the printing paper and store the paper basket.

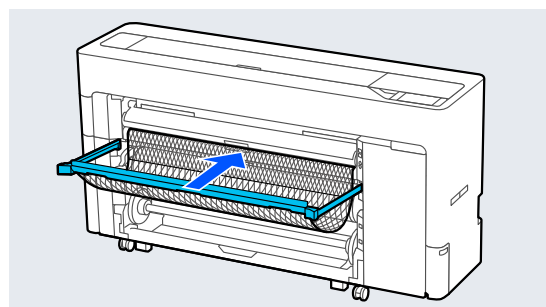

## Basic Operations

### 2 Select Paper Setting - Roll 1 or Roll - Remove.

**Note:**

You can also eject the roll paper by pressing the Roll1 removal button.

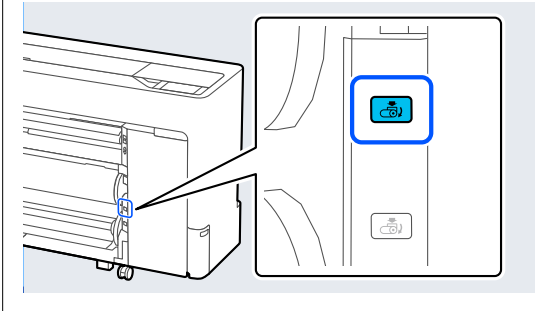

### 3 Raise the spindle lock lever.

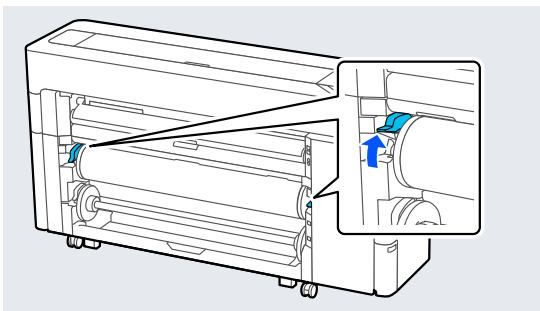

### 4 Remove the spindle.

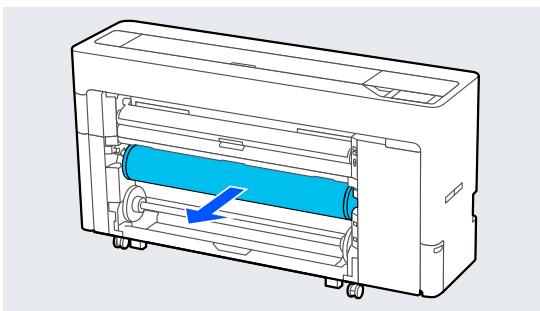

### 5 Remove the transparent media edge guide from the spindle.

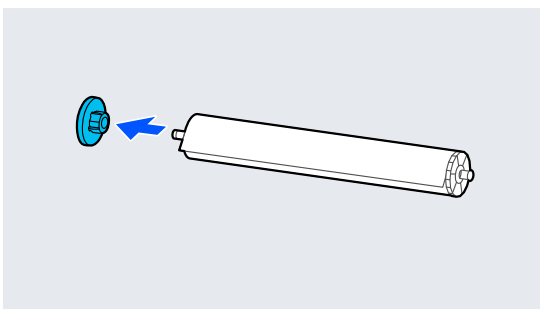

### 6 Remove the roll paper from the spindle.

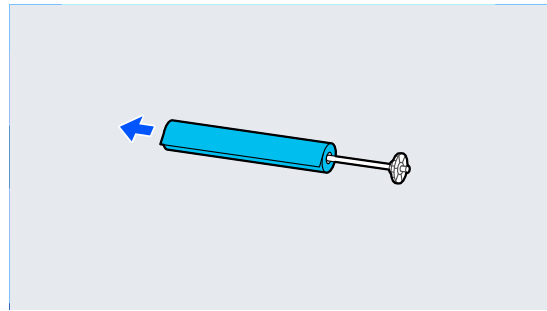

### 7 Attach the transparent media edge guide to the spindle.

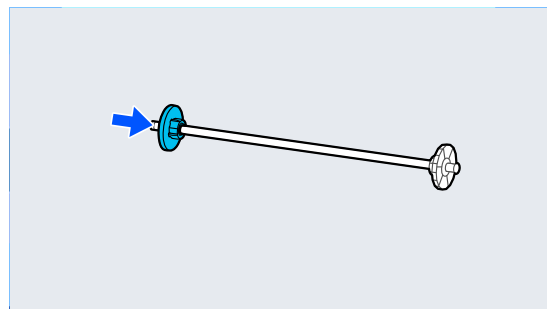

### 8 Place the spindle into the grooves with the black media edge guide on the right.

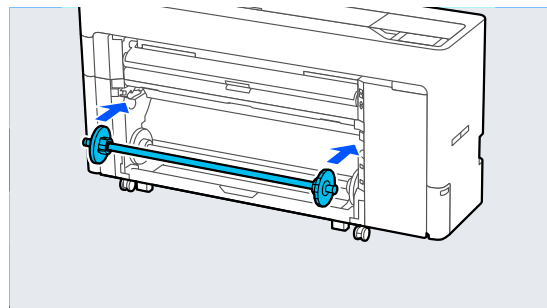

### 9 Lower the spindle lock lever.

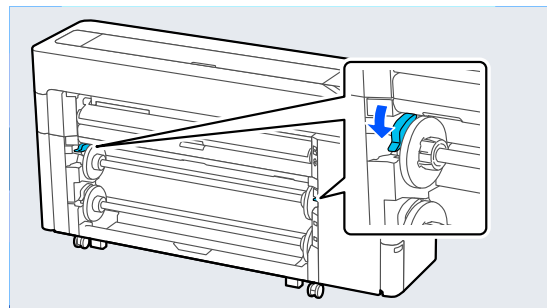

## Basic Operations

### Loading Roll 2 (Except for the SC-P6500E Series/SC-T3700E Series)

- 1 Turn on the printer.
- 2 Set the paper support to the position shown in the illustration.

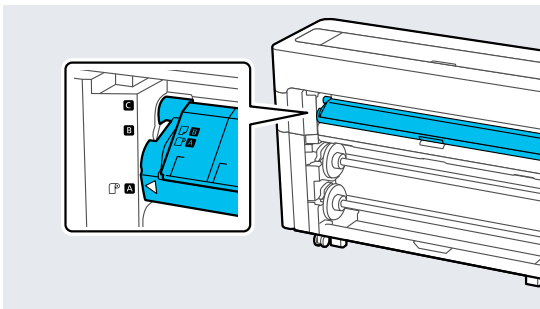
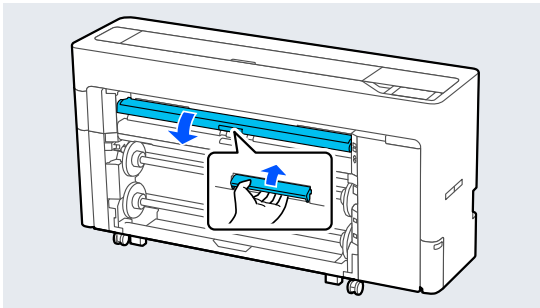

**Note:**  
Close the flap if it is open.

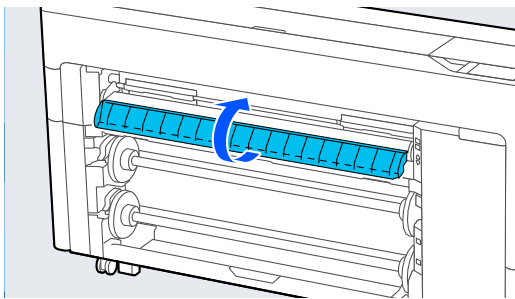

- 3 Raise the spindle lock lever.

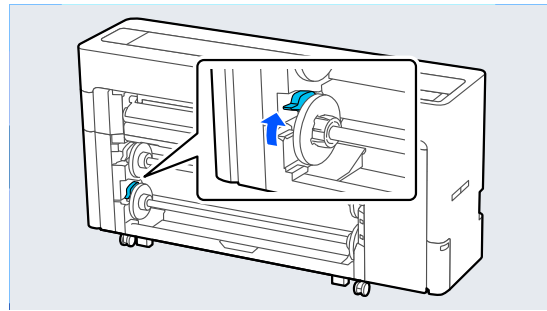

- 4 Pull out the roll 2 unit.

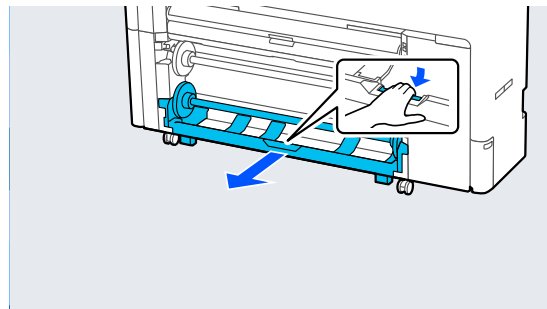

- 5 Remove the spindle.

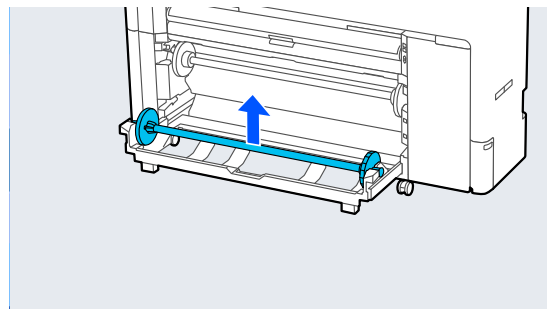

- 6 Remove the transparent media edge guide from the spindle.

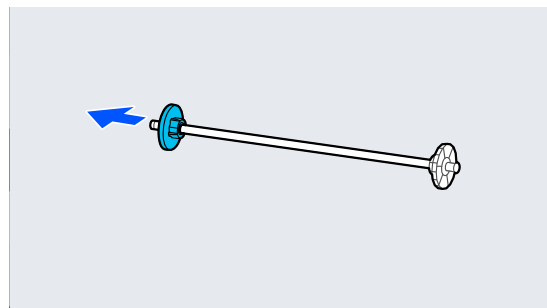

## Basic Operations

- 7** Attach or remove the core adapter according to the core size of the roll paper to be loaded.

### 2-inch core

Remove the core adapters from the media edge guides on both sides.

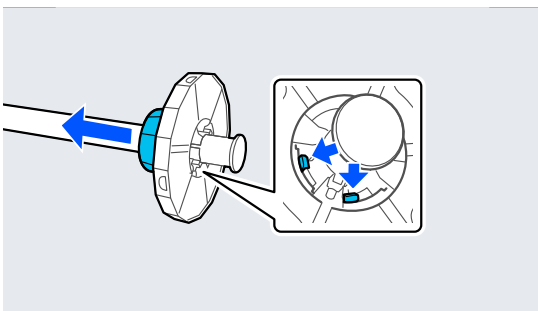
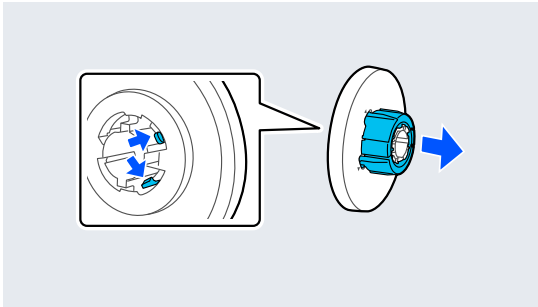

### 3-inch core

Attach the core adapters to the media edge guides on both sides.

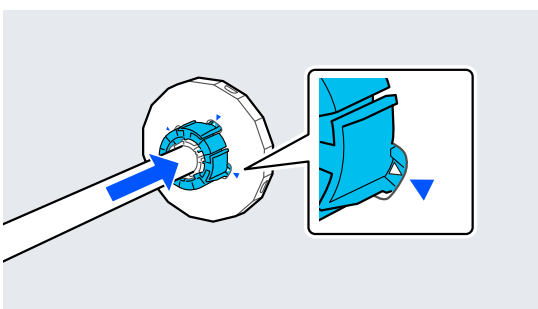
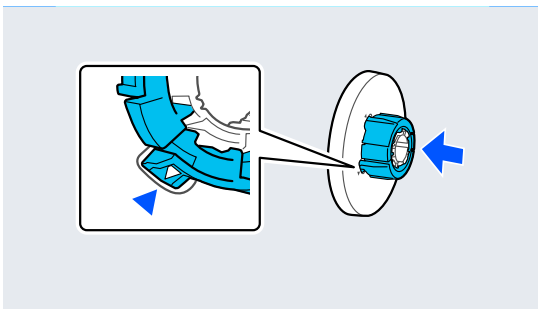

- 8** Insert the spindle with the roll paper facing the direction shown in the illustration.

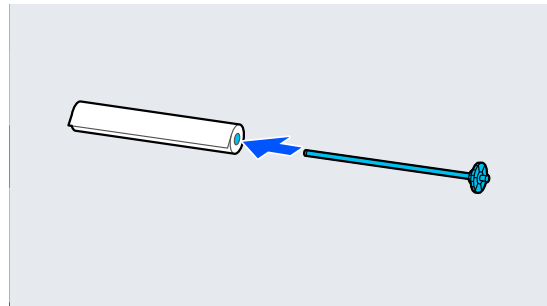

- 9** Attach the transparent media edge guide to the spindle.

Attach them so that there are no gaps between the roll paper and the media edge guides.

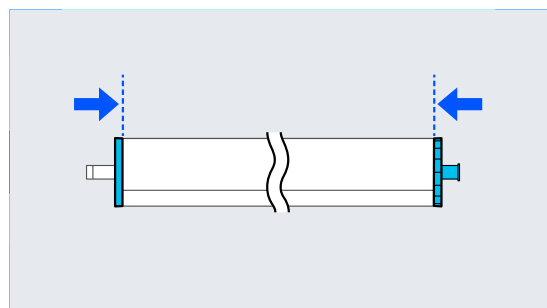
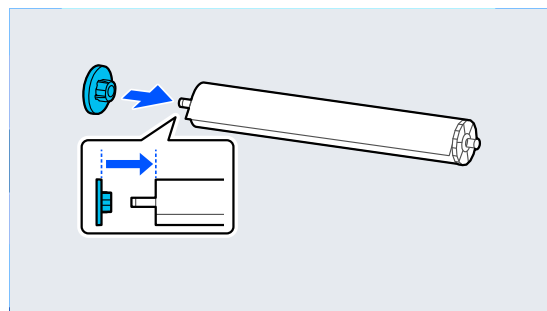

- 10** Place the spindle into the grooves with the black media edge guide on the right.

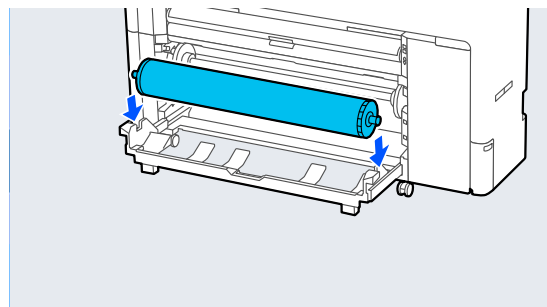

## Basic Operations

- 11** Return the roll2 unit.

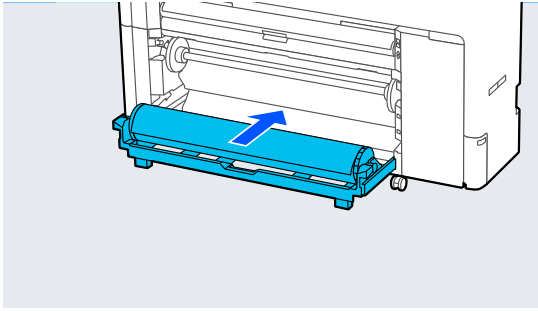

- 12** Lower the spindle lock lever.

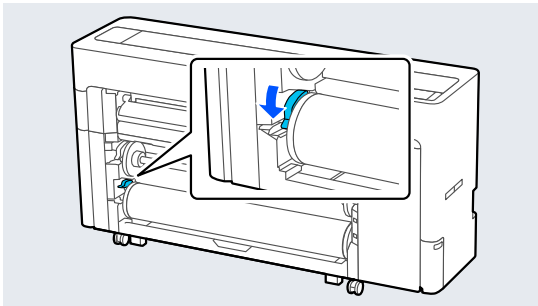

- 13** Pull out the paper basket.

You can stack one sheet at a time in the paper basket. When printing multiple sheets, remove the ejected paper so that print outs do not accumulate in the basket.

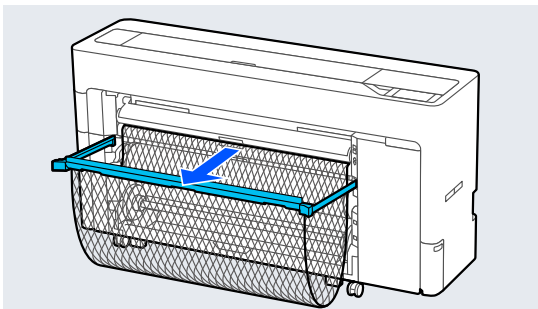

- 14** Make the paper settings.

"Setting Loaded Paper" on page 56

## Removing Roll 2 (Except for the SC-P6500E Series/SC-T3700E Series)

This section describes how to remove the roll paper from the printer after printing. If the roll paper is not cut, select **Menu - Paper Setting - Roll 2 - Feed/Cut Paper** and adjust the cutting position to cut the roll paper.

**!** **Important:**

Do not pull out the roll2 unit while the paper is loaded.

Otherwise, the paper may wrinkle when you return the roll2 unit after it has been pulled out.

When returning the unit, slowly return the roll2 unit while taking-up the paper.

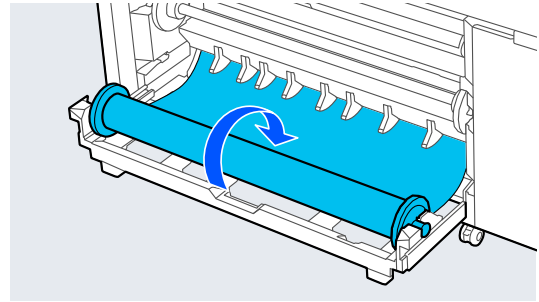

- 1** If the paper basket is pulled out, remove the printing paper and store the paper basket.

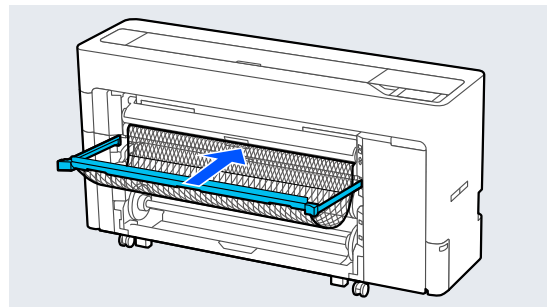

- 2** Select **Menu - Paper Setting - Roll 2 - Remove**.

**Note:**

You can also eject the roll paper by pressing the Roll2 removal button.

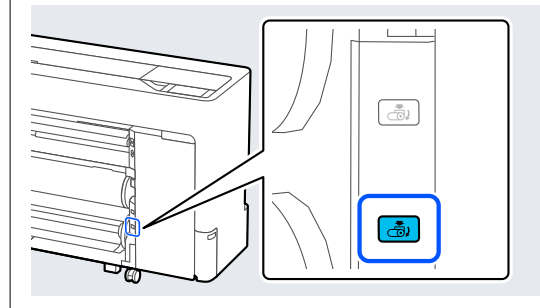

## Basic Operations

- 3** Raise the spindle lock lever.

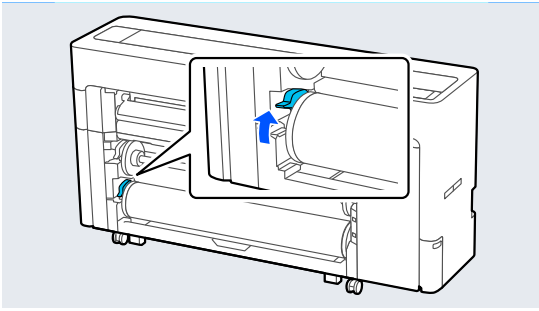

- 4** Pull out the roll2 unit.

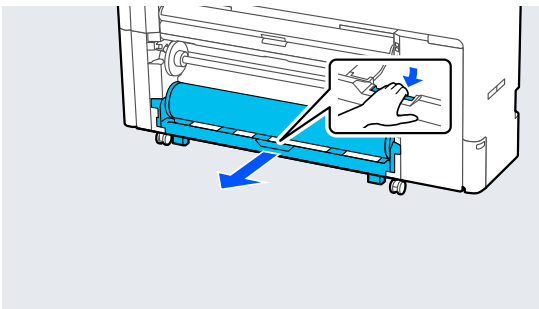

- 5** Remove the spindle.

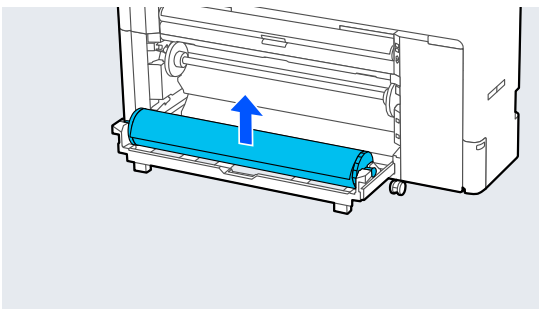

- 6** Remove the transparent media edge guide from the spindle.

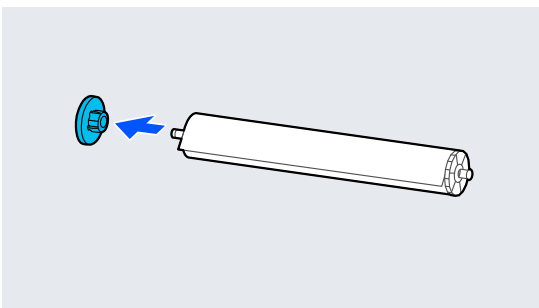

- 7** Remove the roll paper from the spindle.

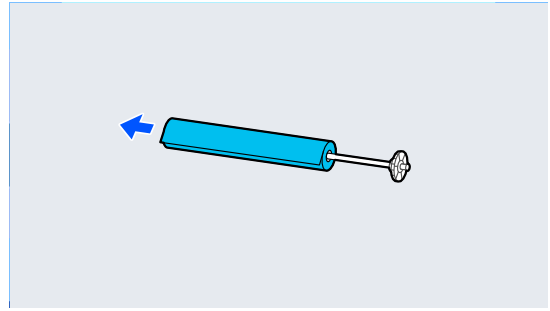

- 8** Attach the transparent media edge guide to the spindle.

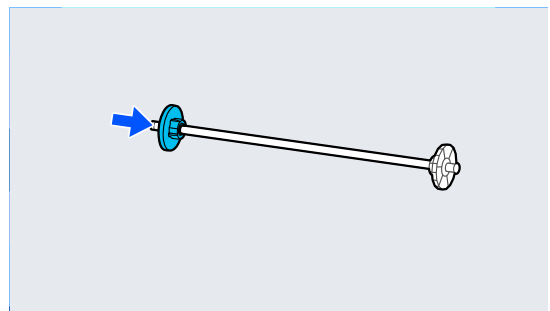

- 9** Place the spindle into the grooves with the black media edge guide on the right.

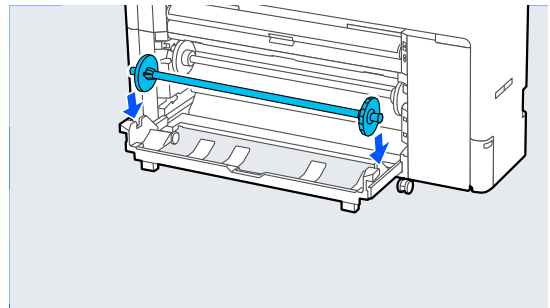

- 10** Return the roll2 unit.

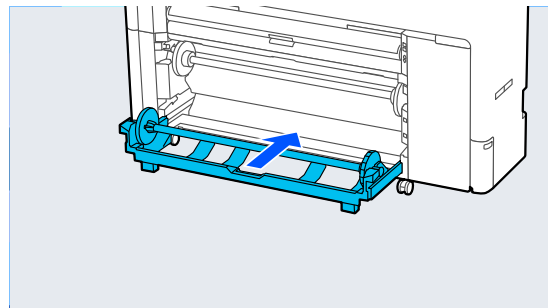

## Basic Operations

- 11** Lower the spindle lock lever.

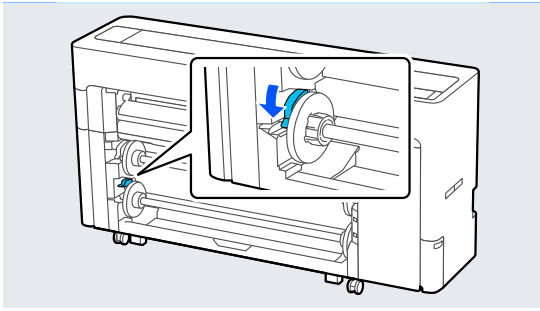

- 3** Set the paper support to the position shown in the illustration.

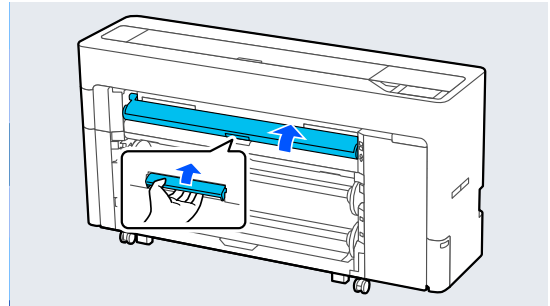

## Loading and Removing Cut Sheets/Poster Board

### Loading Cut Sheets

You can feed the paper from the front or the back. In both cases, the paper is ejected from the front after printing.

Set front feeding or rear feeding on the control panel.

Select the paper feed position from **Menu - General Settings - Printer Settings - Paper Source Settings - Cut Sheet/Poster Board Paper Slot**.

**!** **Important:**

*When printing cut sheets, make sure there is enough space at the rear of the printer.*

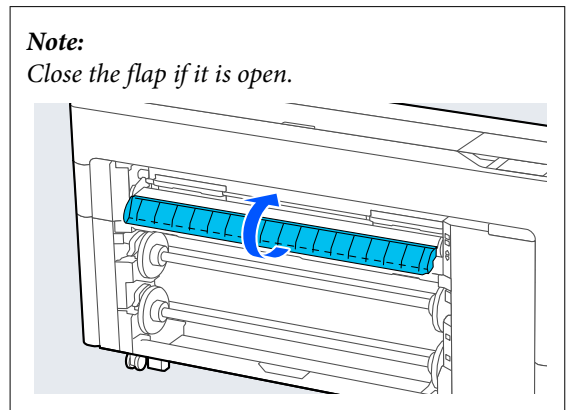
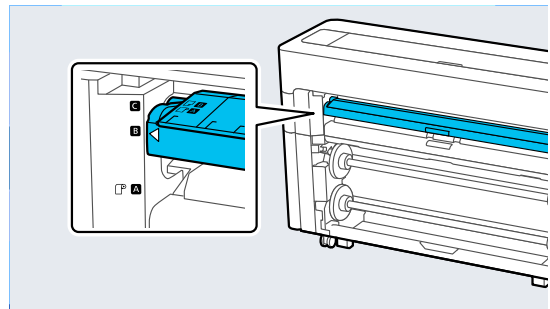

### Feeding paper from the rear of the printer

- 1** Turn on the printer.
- 2** Make the paper settings.  
[☞ "Setting Loaded Paper" on page 56](#)

## Basic Operations

- 4** Go to the rear of the printer, align the paper with the alignment position on the left side with the side to be printed facing up.

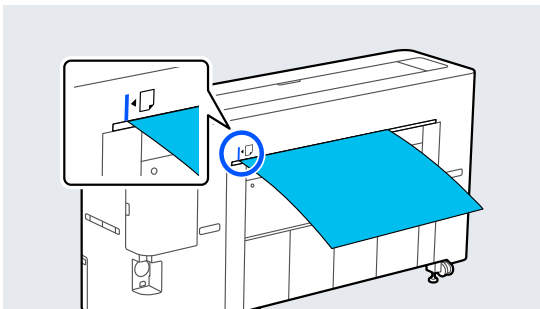
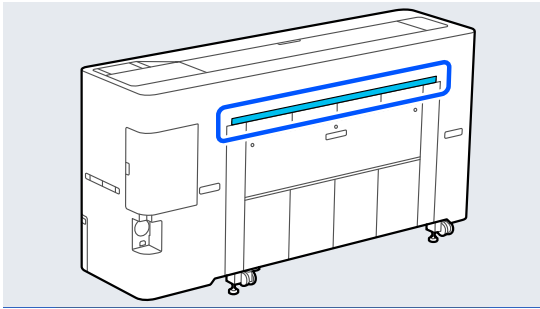

- 5** Insert the paper straight into the printer to the position shown in the illustration.

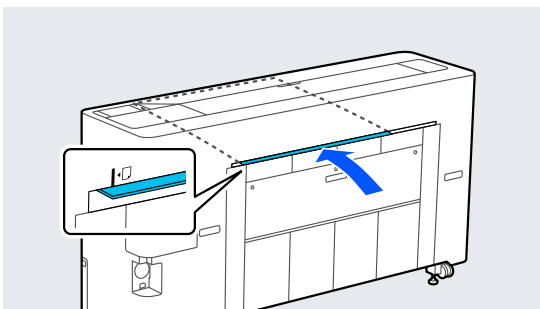
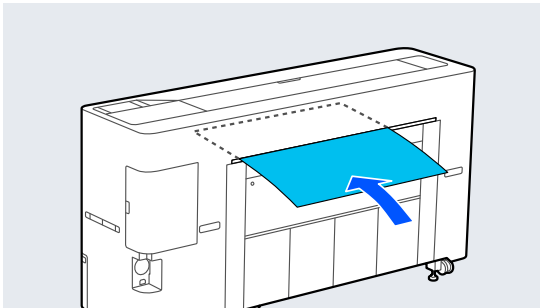

- 6** Pull out the paper basket.

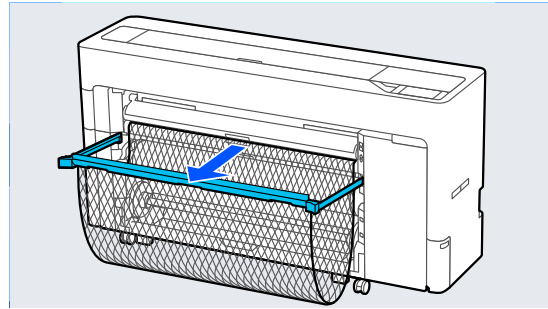

### Feeding paper from the front of the printer

**!** **Important:**

*If paper with a firm curl is fed from the front, the paper may get jammed and cannot be inserted. In this case, feed the paper from the back.*

- 1** Turn on the printer.
- 2** Make the paper settings.  
 ↗ [“Setting Loaded Paper” on page 56](#)
- 3** Set the paper support to the position shown in the illustration.

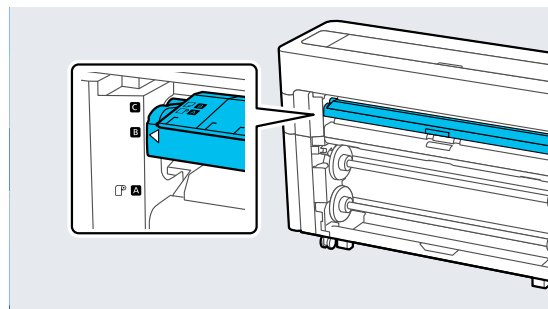
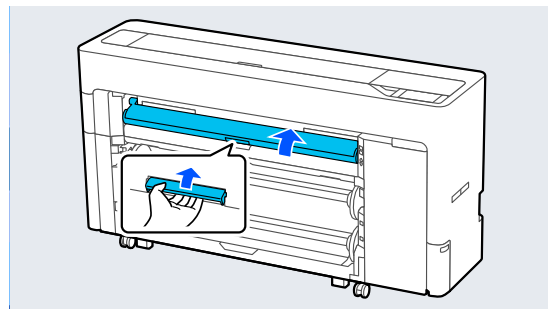

## Basic Operations

**Note:**

Close the flap if it is open.

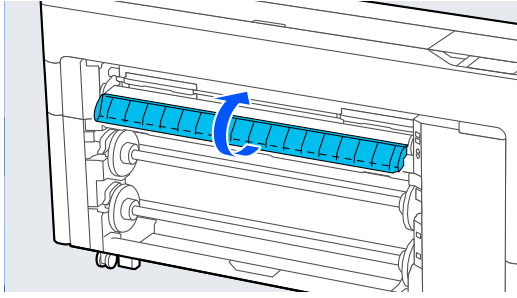

**4**

Align the paper with the alignment position on the right side with the side to be printed facing up.

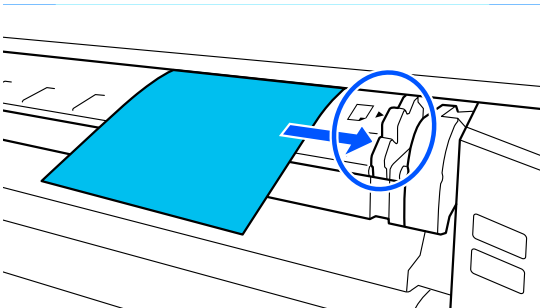
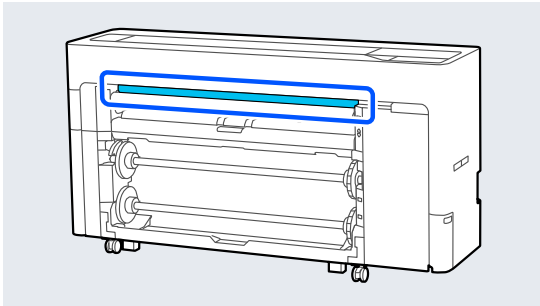

**5**

Insert the paper.

**When using cut sheets with a paper length of 297 mm or longer:**

Insert the paper straight into the printer to the position shown in the illustration.

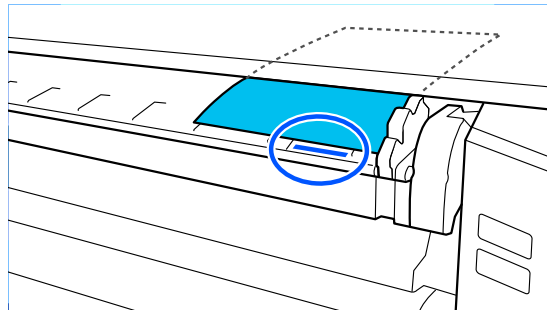
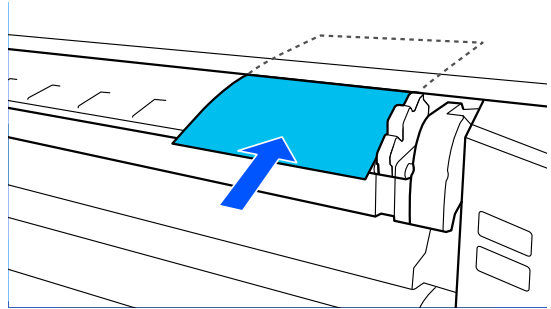

Make sure that it passes under the internal rollers.

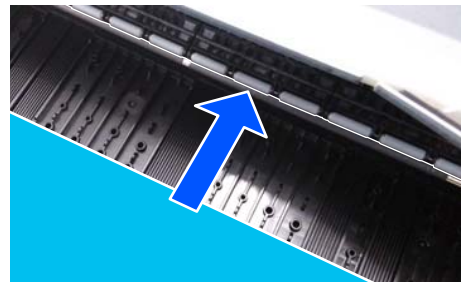

## Basic Operations

**When using cut sheets with a paper length shorter than 297 mm:**

Insert the paper past the alignment mark, making sure that it passes under the internal rollers.

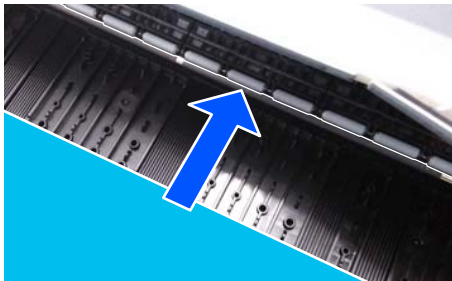
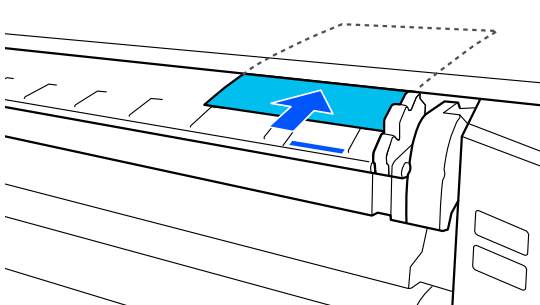

**6** Pull out the paper basket.

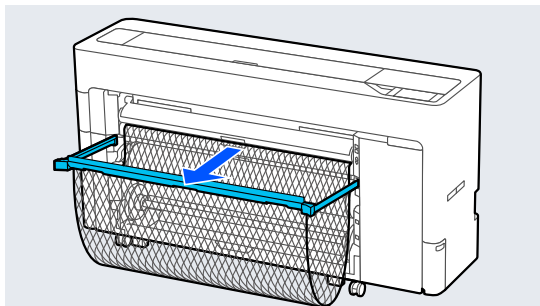

## Loading Poster Board

You can feed the paper from the front or the back. In both cases, the paper is ejected from the front after printing.

Set front feeding or rear feeding on the control panel.

Select the paper feed position from **Menu - General Settings - Printer Settings - Paper Source Settings - Cut Sheet/Poster Board Paper Slot**.

### **!** Important:

- When printing poster board, make sure there is enough space at the rear of the printer.
- Feed poster board in a portrait orientation. If you feed the paper in a landscape orientation, the print quality may decline.

## Feeding paper from the rear of the printer

- 1** Turn on the printer.
- 2** Make the paper settings.  
🔗 [“Setting Loaded Paper” on page 56](#)
- 3** Set the paper support to the position shown in the illustration.

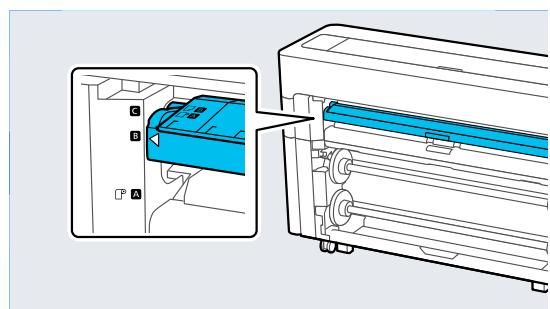
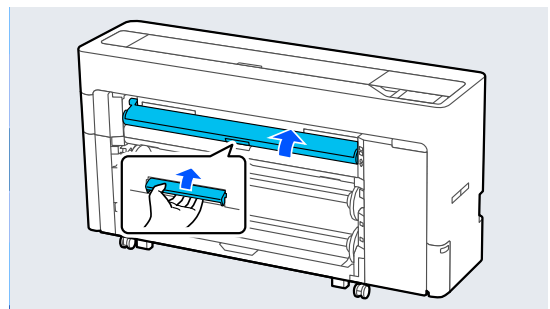

## Basic Operations

**Note:**

Close the flap if it is open.

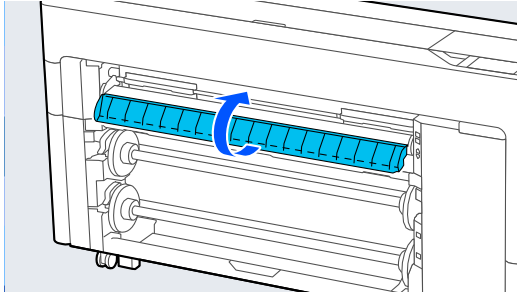

**4**

Go to the rear of the printer, align the paper with the alignment position on the left side with the side to be printed facing up.

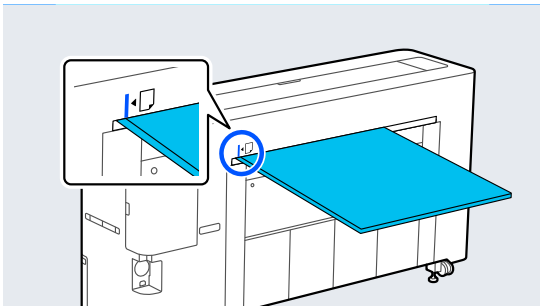
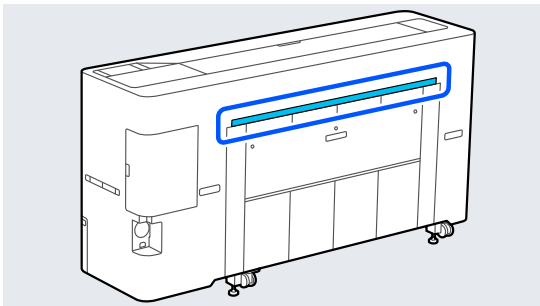

**5**

Insert the paper straight into the printer to the position shown in the illustration.

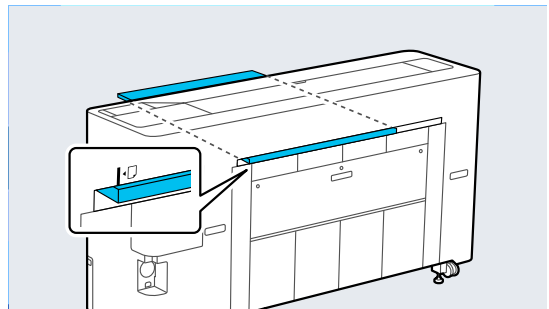
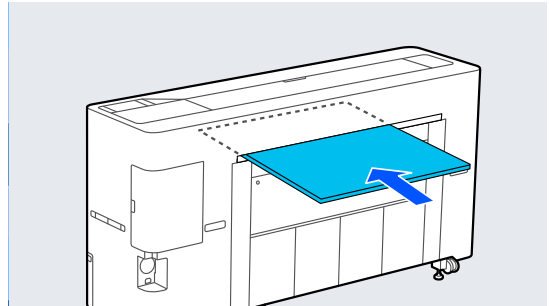

**6**

When loading poster board with a paper length of 600 mm or more, pull out the paper basket to reduce bending of the poster board while printing.

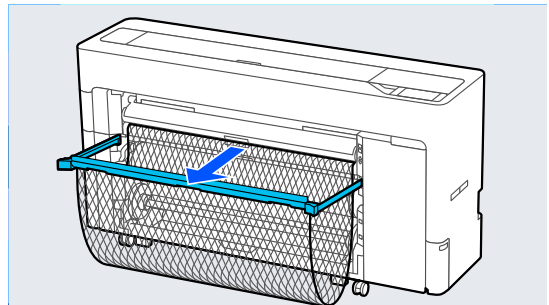

The paper basket supports the poster board which reduces bending while printing.

**While printing**

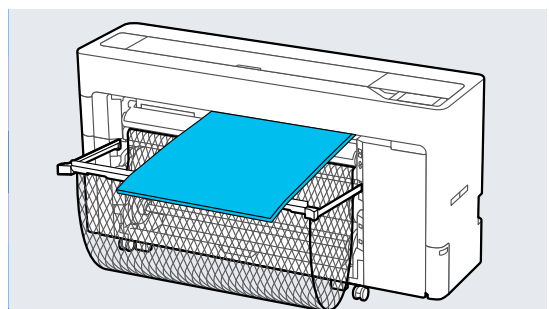

## Basic Operations

### Feeding paper from the front of the printer

**!** **Important:**

*If paper with a firm curl is fed from the front, the paper may get jammed and cannot be inserted. In this case, feed the paper from the back.*

- 1** Turn on the printer.
- 2** Make the paper settings.  
🔗 “Setting Loaded Paper” on page 56
- 3** Set the paper support to the position shown in the illustration.

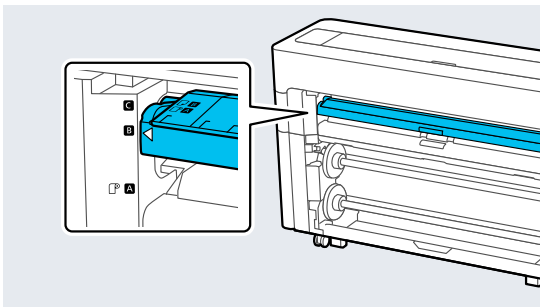
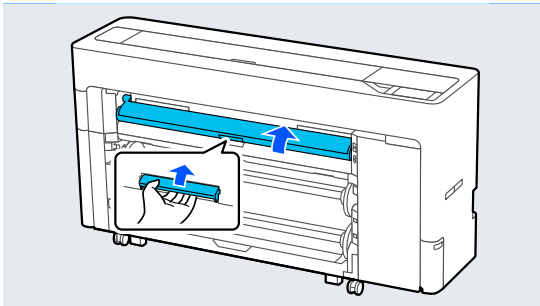

**Note:**  
Close the flap if it is open.

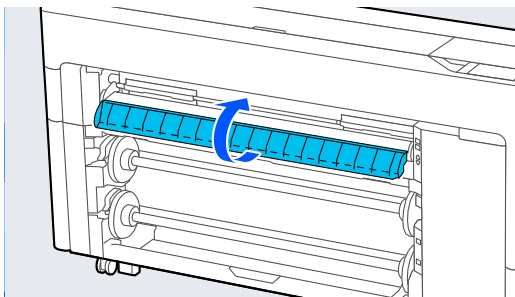

- 4** Align the paper with the alignment position on the right side with the side to be printed facing up.

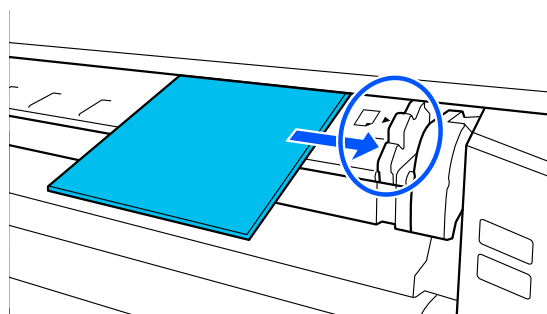
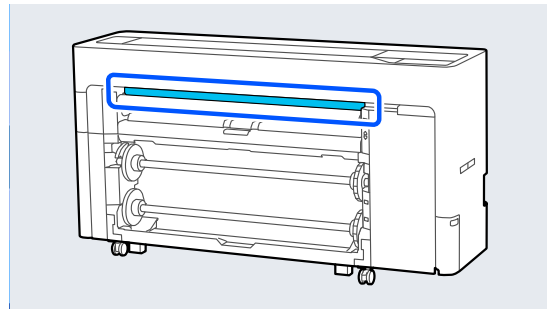

- 5** Insert the paper straight into the printer to the position shown in the illustration.

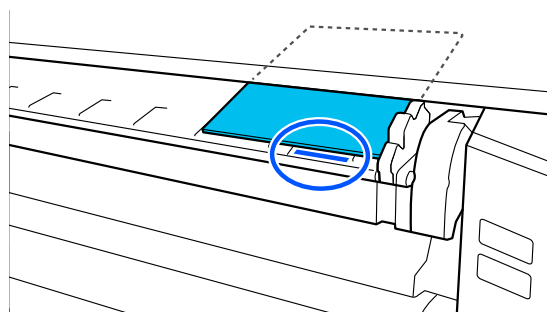
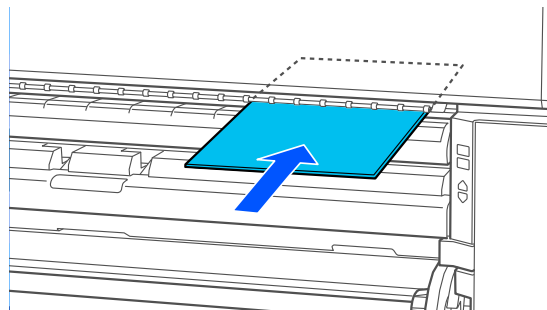

## Basic Operations

### **Important:**

Insert the poster board making sure that it passes under the internal rollers.

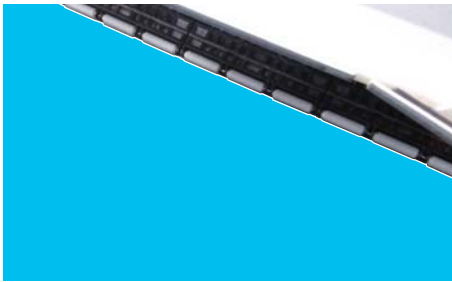
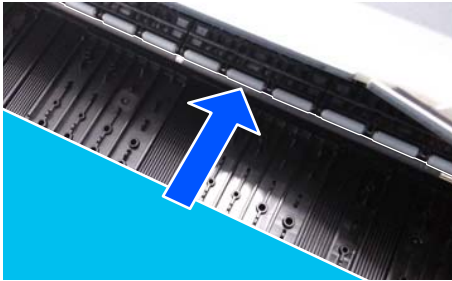

- 6** When loading poster board with a paper length of 600 mm or more, pull out the paper basket to reduce bending of the poster board while printing.

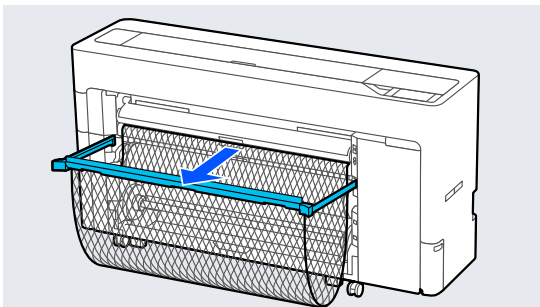

The paper basket supports the poster board which reduces bending while printing.

### While printing

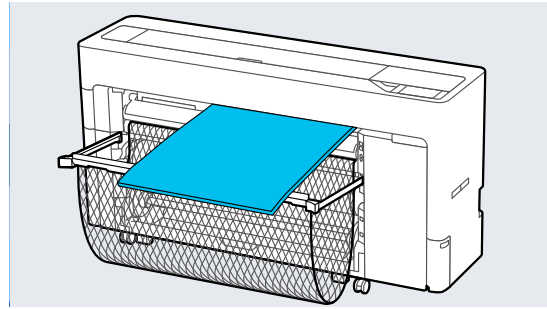

## Removing Cut Sheets/Poster Board

- 1** Select Menu - Paper Setting - Cut Sheet or Poster Board - Remove.
- 2** While supporting the paper so that it does not fall, press OK.

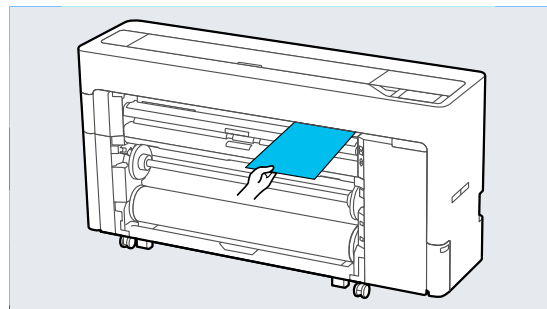

- 3** If the paper basket is pulled out, remove the printing paper and store the paper basket.

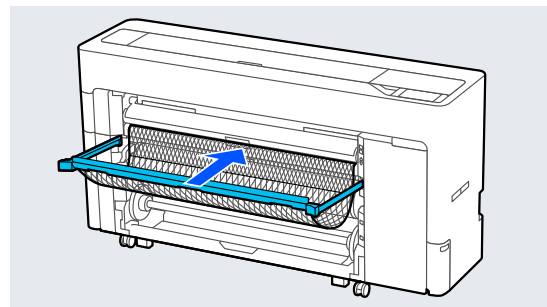

## Setting Loaded Paper

Set the paper type before you start printing. Not setting a paper type that matches the loaded paper will cause wrinkles, scuffing, uneven colors, and other trouble.

## Basic Operations

### Note:

- ❑ Set the same settings in the printer driver as the paper type you have set.  
If the paper type settings on the control panel and in the printer driver are different, the paper settings in the printer driver take precedence. However, if the paper type set on the control panel is the same as the paper type saved in Custom Paper Setting, the paper settings on the control panel take priority. See the following for more details on Custom Paper Setting.  
☞ [“Make custom paper settings on the control panel” on page 61](#)
- ❑ When using roll paper that is easily damaged, select **Menu - General Settings - Printer Settings - Paper Source Settings - Roll Paper Setup - Auto Loading - Off** before loading the paper. See the following for details on feeding roll paper manually.  
☞ [“Feeding Roll Paper Manually” on page 63](#)

## How to Set

- 1 Select the loaded paper in **Menu - Paper Setting**.
- 2 Check that the loaded paper and the paper type displayed on the screen match.

### Roll Paper

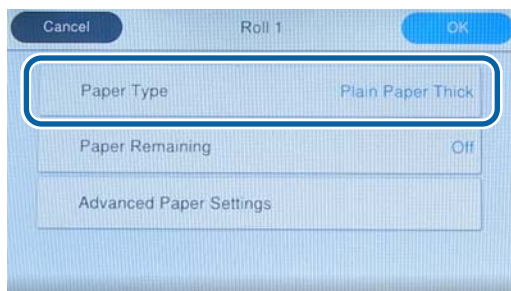

### Cut sheet/Poster board

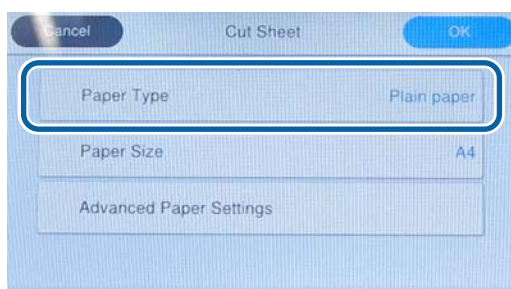

If the paper type displayed does not match the paper type that you have loaded, press **Paper Type** to set the paper type.

See the following if the paper type you have loaded is not displayed on the control panel.

☞ [“When the paper type is not displayed on the control panel or in the driver” on page 58](#)

- 3 To manage the amount of roll paper remaining, set **Remaining Amount Management to On**, and then set **Remaining Amount** and **Remaining Alert**.



### Note:

When **Manage Remaining Amount** is set, a barcode is printed on the leading edge of the paper when you remove the roll paper. The next time you load the roll paper, the amount remaining and the paper type are set automatically.

However, depending on the paper, the printer may not be able to read the barcode.

- 4 For cut sheets/poster board, check that the loaded paper and the paper size displayed on the screen match.

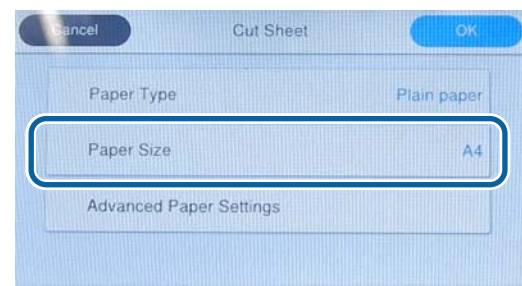

If the loaded paper does not match the paper size displayed on the screen, press **Paper Size** to set the paper size.

## Basic Operations

- 5** Press **OK** on the paper setting screen to start feeding the paper.

When the message "Ready to print." is displayed on the Home screen, you can start printing.

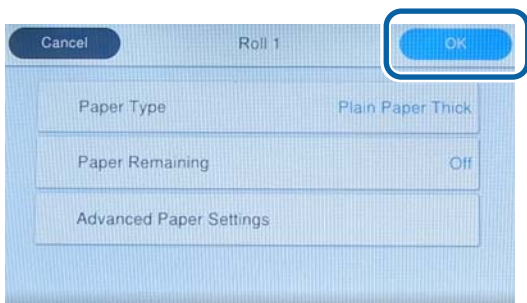

**Note:**

To make detailed paper settings such as the platen gap, press **Advanced Paper Settings**, and then set each item.

See the following for items you can set.

[☞ "Menu List" on page 138](#)

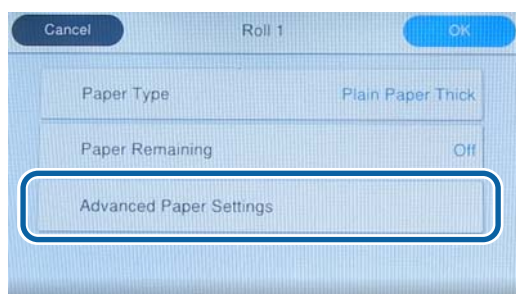

The advanced paper settings are saved for the currently selected paper type.

When **Roll Paper Setup - Auto Loading - Off** is selected, or if the roll paper cannot be fed automatically, feed the roll paper manually. See the following for details on feeding roll paper manually.

[☞ "Feeding Roll Paper Manually" on page 63](#)

## When the paper type is not displayed on the control panel or in the driver

If the paper type is not displayed on the control panel or in the printer driver, you can use one of the following methods to make paper settings.

- Use Epson Media Installer
- Make custom paper settings on the control panel
- Use Epson Edge Print  
(For details on how to use Epson Edge Print, see the Epson Edge Print manual.)

## Use Epson Media Installer

This allows you to add paper information from the Internet. You can also edit the paper information you have added.

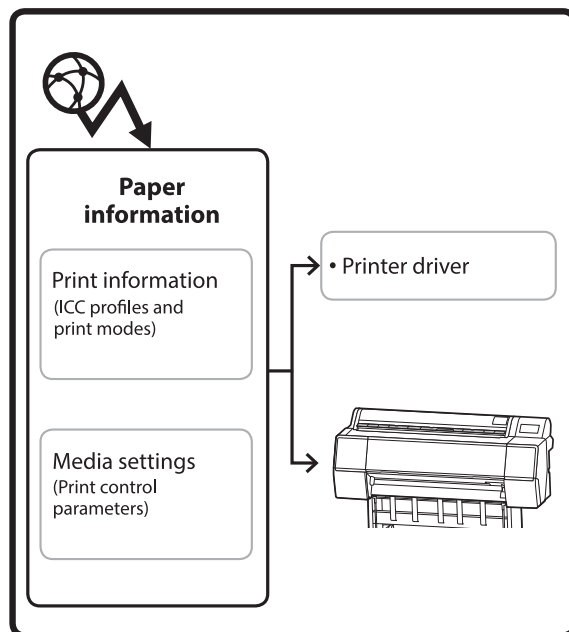

Paper information, including ICC profiles, print modes, and print control parameters, is downloaded from servers.

Downloaded paper information is saved in the printer driver or the printer.

**Note:**

You need to download Epson Media Installer. See your printer's support page for details on installation.

See the following for more information.

[☞ "Introducing the Software" on page 26](#)

## Basic Operations

### Adding Paper Information

**1** Use one of the following methods to start Epson Media Installer.

#### For Windows

Start Epson Media Installer.  
Start/Epson Software/Epson Media Installer

#### For Mac

Start Epson Media Installer.  
/Applications/Epson Software/Epson Utilities/  
Epson Media Installer.app

#### Printer driver (Windows)

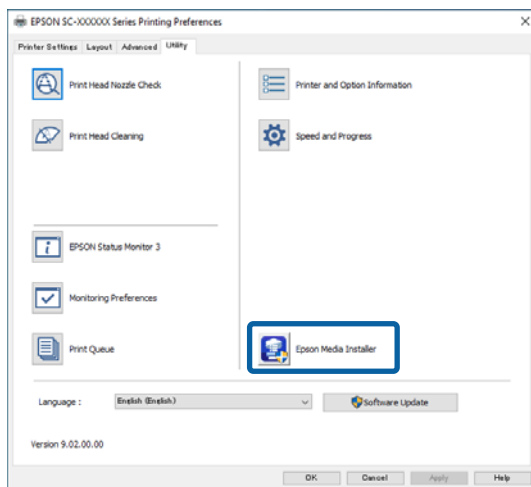

#### Epson Edge Dashboard



Epson Media Installer starts and displays a list of paper information that you can add.

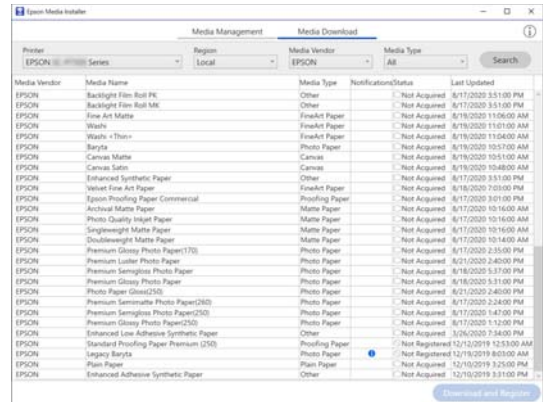

**2** Add the paper information. Select the paper you want to use, and then click **Download and Register** to add the selected paper information.

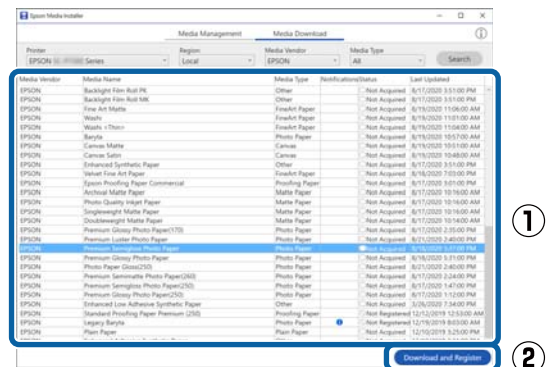

**3** Paper information is added to the paper type for the printer driver.

Select the paper you want to print on.

**Note:**

Paper information added using Epson Media Installer is also added to **Printer Settings - Custom Paper Setting** on the control panel.

You cannot change the paper information settings on the control panel.

## Basic Operations

### Printer driver (Windows)

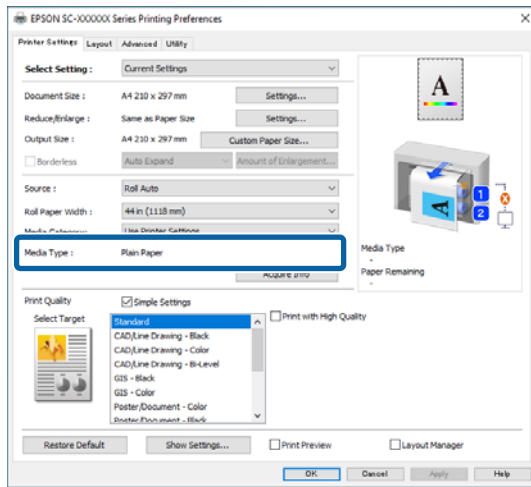

### Printer driver (Mac)

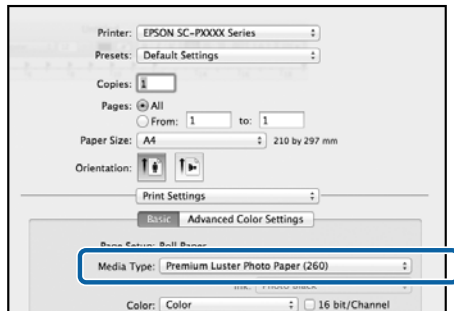

#### **Important:**

If you uninstall and reinstall the printer driver, use Epson Media Installer to re-register the paper information.

If you do not re-register the paper information, paper information added previously using Epson Media Installer may not be displayed in the printer driver.

#### Re-registering Paper Information

Start Epson Media Installer, and then click **Media Management - Refresh**.

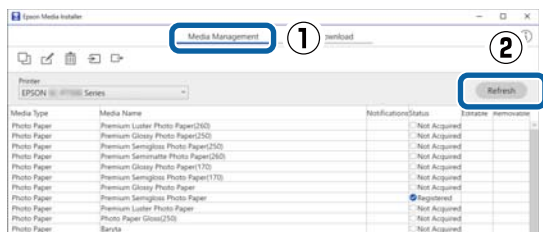

### Editing Paper Information

To edit the paper information, copy the added paper information and then change the settings. You cannot directly edit the added paper information.

- 1 Start Epson Media Installer, and then click **Media Management**.

Displays paper information stored on the printer.

However, paper information set in **Custom Paper Setting** on the printer's control panel is not displayed.

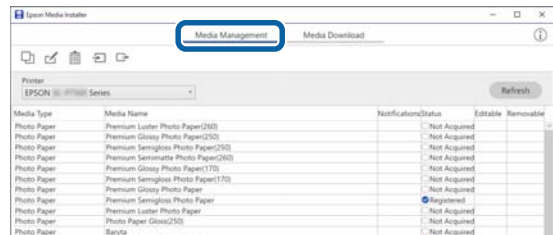

- 2 Select the paper information you want to edit, and then click (Copy Media).

You can only copy paper information that has **Registered** displayed as the **Status** in the list.

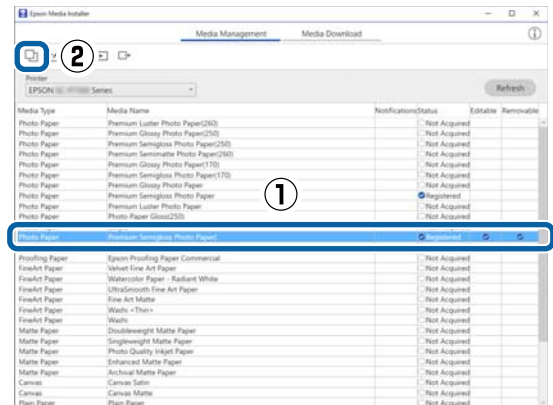

A copy of the paper information is created. The copy has the word "(Copy)" displayed at the end of the media name.

## Basic Operations

- 3 Select the paper information you copied, and then click  (Edit).

The Edit Media Settings screen is displayed.

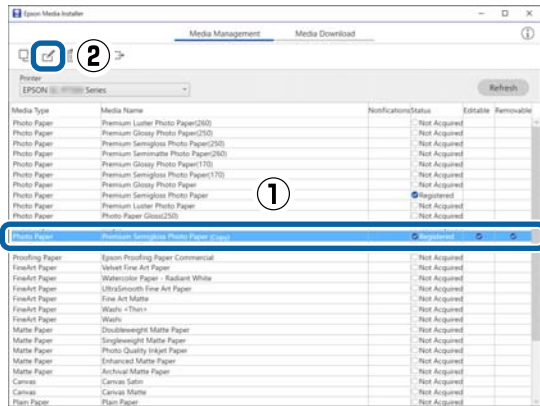

- 4 Change the settings according to your printing needs and so on, and then click OK.

See the following for more details on the Edit Media Settings screen.

 [“Edit Media Settings Screen Configuration” on page 32](#)

- 5 The edited paper information is reflected in the printer driver.

### Make custom paper settings on the control panel

- 1 Select **General Settings - Printer Settings - Custom Paper Setting** on the control panel.

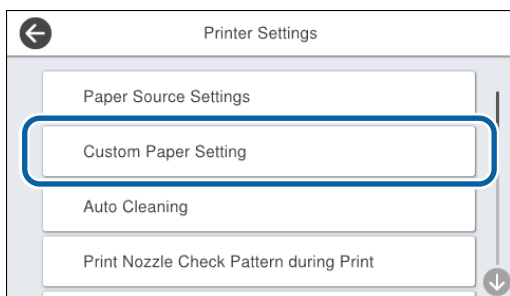

- 2 Select a paper number from 1 to 30 to save the settings.

- 3 Set the paper information.  
Make sure you set the following items.

- Change Reference Paper
- Paper Thickness
- Roll Core Diameter (roll paper only)

- Paper Feed Offset

**Note:**

**Paper Feed Offset** is a function that allows you to adjust the difference between the data size and the print size.

**Example:**

When printing at a data size of 100 mm and a print size of 101 mm, the offset is 1.0%. Therefore, you would enter a value of -1.0%.

See the following for details on the other settings.

 [“General Settings” on page 147](#)

## Optimizing Media Settings (Automatic Adjustment)

You should optimize the media settings in the following situations. To optimize the media settings, perform **Automatic Adjustment from Print Adjustments** in the printer's menu.

### When you have registered media settings from paper information to the printer

When paper information has been added using the Epson Media Installer, optimize the media settings to correct individual differences in your media and printer so that you can perform optimal printing using your combination of media and printer.

### When you have changed the Advanced setting after saving media settings.

## Precautions when performing Print Adjustments

**Adjustments are made depending on the paper loaded in the printer.**

- Under the actual printing conditions, correctly load the media that needs to be adjusted in the printer.  
When printing using the auto take-up function, load the auto take-up and then perform Print Adjustments.

## Basic Operations

- ❑ Make sure you select the name set when you added the media setting value or set in **Custom Paper Setting** from the printer's menu as the **Paper Type**.

### Make sure nozzles are not clogged before adjusting.

If nozzles are clogged, adjustments will not be performed correctly.

Perform Print Head Nozzle Check to check if the nozzles are clogged, and then perform Print Head Cleaning if necessary.

 [“Print Head Nozzle Check” on page 172](#)

Auto adjustment cannot be performed when using the following paper.

- ❑ Plain Paper
- ❑ Enhanced Matte Board
- ❑ Transparent or colored paper

Perform manual adjustment when using these types of paper.

 [“If you cannot perform Automatic Adjustment” on page 62](#)

---

## Automatic Adjustment Procedure

Automatic Adjustment performs Paper Feed Adjust and Print Head Alignment automatically while printing the pattern.

The pattern is printed. Load paper that is 388 mm or wider and 558 mm or longer.

You may not be able to perform Automatic Adjustment depending on the media you are using. If an error occurs, or if you notice banding or graininess in the print results even after performing Automatic Adjustment, perform **Paper Feed Adjust** and **Ruled Line Alignment** from the Print Adjustments menu.

 [“If you cannot perform Automatic Adjustment” on page 62](#)

**1** Check that the printer is ready, and load the media according to the actual usage conditions.

**2** From the Home screen, press **Paper Setting - Roll 1/Roll 2/Cut Sheet/Poster Board - Print Adjustments - Automatic Adjustment**.

**3** Press **Standard - Auto Adjustment - Start**.

Auto adjust starts, and the adjustment pattern is printed.

Wait until adjustment is complete.

### Note:

Perform the following if you are not satisfied with the adjustments made by **Automatic Adjustment - Standard**, or if you want to perform **Automatic Adjustment** to match your printing needs.

Select **Automatic Adjustment - Details - Auto Adjustment**. Select the items that suits your printing needs in **Select Target** and **Print Quality**, and then press **Start**.

---

## If you cannot perform Automatic Adjustment

Perform **Paper Feed Adjust** and **Ruled Line Alignment** separately. In both cases, visually inspect the printed pattern and enter the measurements to perform adjustments.

Before making adjustments, be sure to read the following:

 [“Precautions when performing Print Adjustments” on page 61](#)

### Paper Feed Adjust

This menu is also used when banding (horizontal banding, tint unevenness, or stripes) is detected in printing results.

To adjust from the Home screen, press **Paper Setting - Roll 1/Roll 2/Cut Sheet/Poster Board - Print Adjustments - Paper Feed Adjust - Manual**.

 [“Paper Feed Adjust” on page 175](#)

## Basic Operations

### Ruled Line Alignment



This menu is also used when graininess is detected in printing results.

To adjust from the Home screen, press **Paper Setting - Roll 1/Roll 2/Cut Sheet/Poster Board - Print Adjustments - Ruled Line Alignment - Manual (Standard)**.

 [“Ruled Line Alignment” on page 176](#)

### Feeding Roll Paper Manually

When **Roll Paper Setup - Auto Loading- Off** is selected, or if the roll paper cannot be fed automatically, follow the steps below to feed the roll paper manually.

- 1** Load the roll paper.
  -  [“Loading Roll 1/Roll paper” on page 42](#)
  -  [“Loading Roll 2 \(Except for the SC-P6500E Series/SC-T3700E Series\)” on page 46](#)

- 2** Insert the leading edge of the roll paper into the paper feed slot, and continue to feed until you hear a sound.

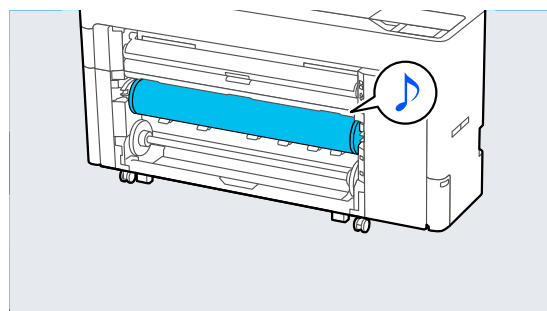
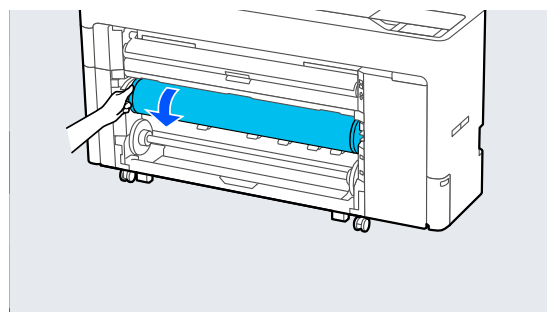
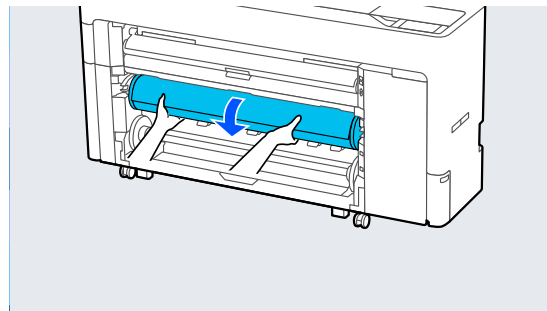

### Loading Paper for Auto Take-up (Except for the SC-P6500E Series/ SC-T3700E Series)

You can use roll 1 as a take-up unit in either the printed side in or printed side out direction.

Printed side out

Printed side in

## Basic Operations

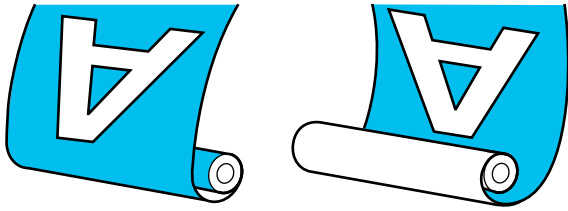

Taking-up with printed side out places the printed surface on the outside of the roll.

Taking-up with printed side in places the printed surface on the inside of the roll.

### Loading Method for Auto Take-up

#### Important:

Skewing errors may occur when automatically taking up thick paper such as enhanced matte paper or fine art paper. If a skewing error occurs, the print position may shift causing print quality to decline. Check the print quality, clear the error and continue using the printer, or change the paper type.

- 1 Turn on the printer.
- 2 Select **Menu - General Settings - Printer Settings - Paper Source Settings - Roll Paper Setup - Roll1 Function - Take-up**.
- 3 Load roll paper in the roll2 unit.  
See the following for more details on loading roll paper.  
[☞ “Loading Roll 2 \(Except for the SC-P6500E Series/SC-T3700E Series\)” on page 46](#)
- 4 Make the paper settings.  
[☞ “Setting Loaded Paper” on page 56](#)
- 5 Select **Menu - Paper Setting - Roll 2 - Prepare for Take-up**.  
Press **Proceed** to display the take-up procedure on the control panel. Follow the instructions on the panel to load the take-up media.

- 6 Raise the spindle lock lever for roll1.

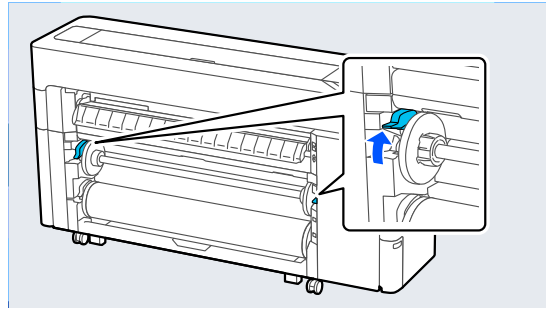

- 7 Remove the spindle.

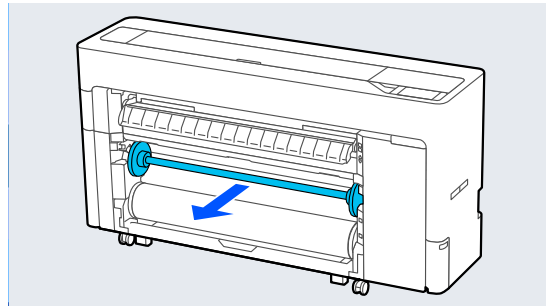

- 8 Remove the transparent media edge guide from the spindle.

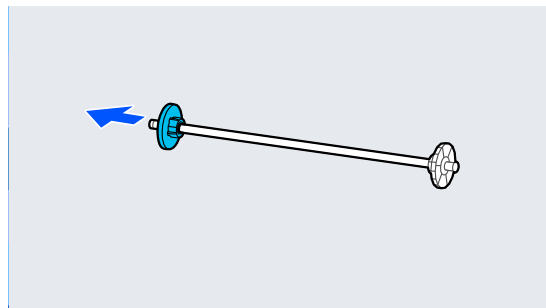

## Basic Operations

- 9** Remove the rim of the media edge guide from the end.

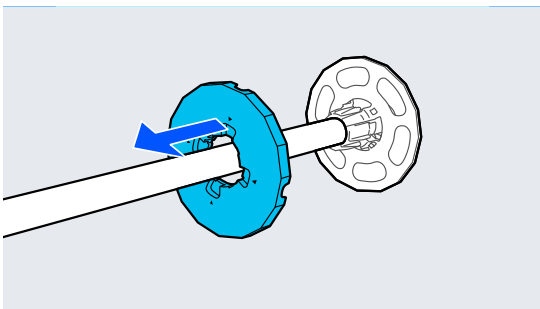
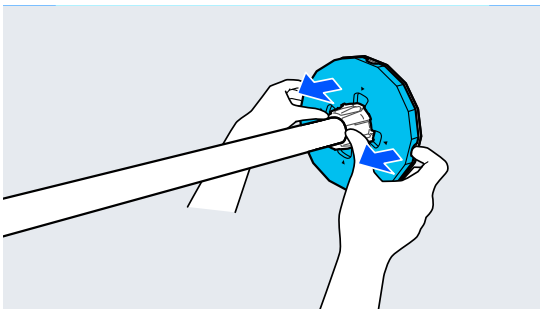
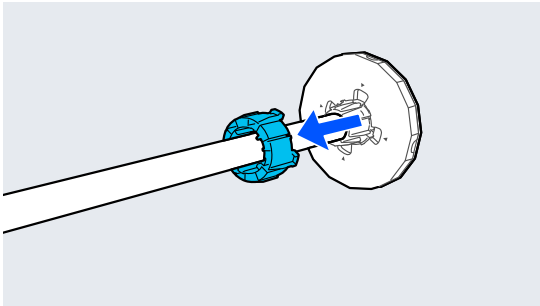

- 10** Attach or remove the core adapter according to the core size of the roll paper to be loaded.

### 2-inch core

Remove the core adapters from the media edge guides on both sides.

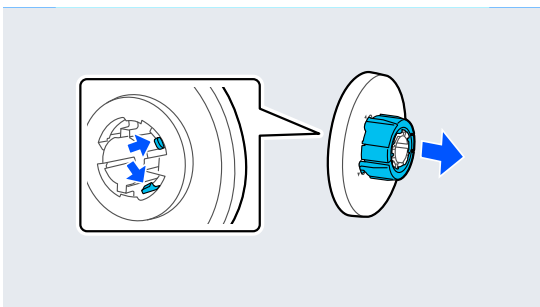

### 3-inch core

Attach the core adapters to the media edge guides on both sides.

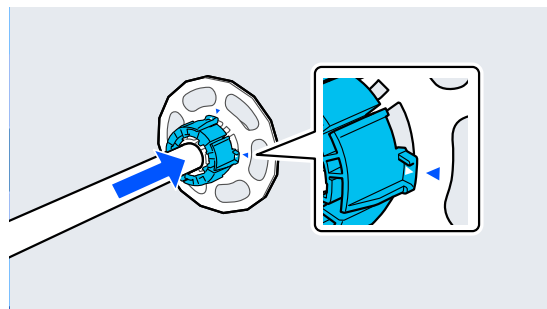
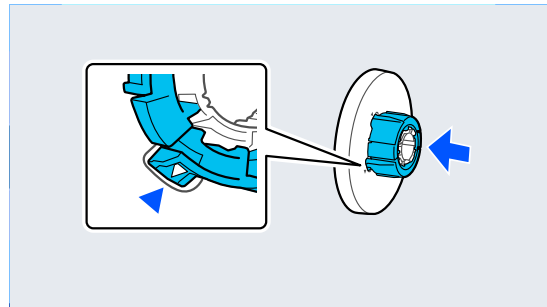

- 11** Insert the spindle into the roll core.

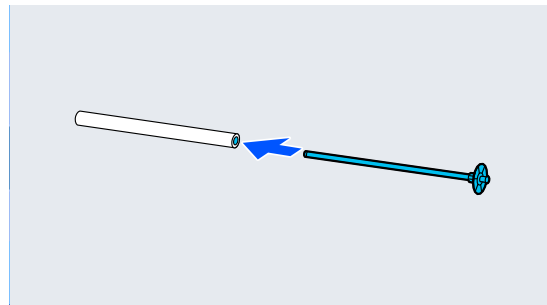

## Basic Operations

- 12** Attach the transparent media edge guide to the spindle.

Attach it so that the gap between the roll core and the media edge guide is approximately 10 mm (0.4 in.).

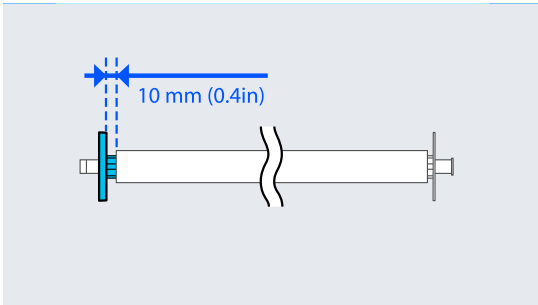
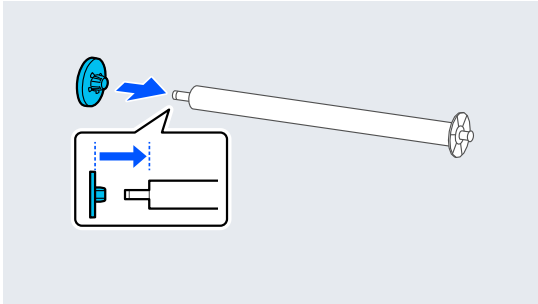

- 13** Place the spindle into the grooves with the black media edge guide on the right.

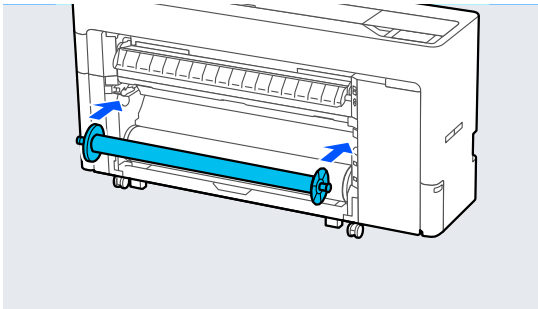

- 14** Lower the spindle lock lever.

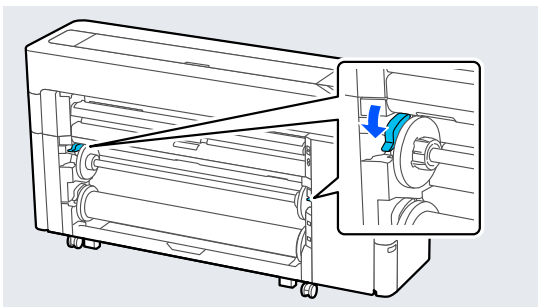

- 15** Press the pause/resume button, and then use the take-up direction switch to select either printed side in or printed side out.

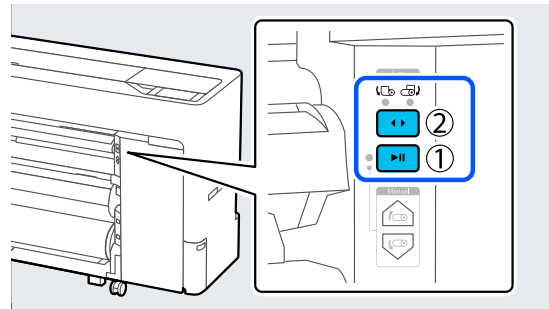

After selecting the take-up direction, press the pause/resume button.

## Basic Operations

- 16** Set the paper support to the position shown in the illustration, and then open the flap.

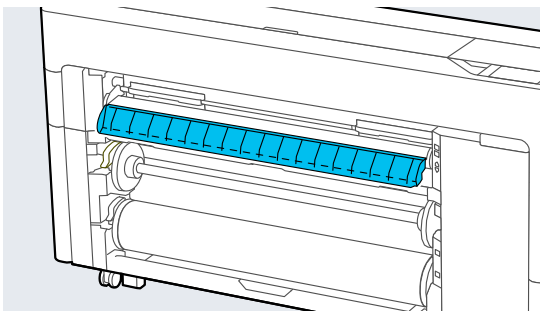
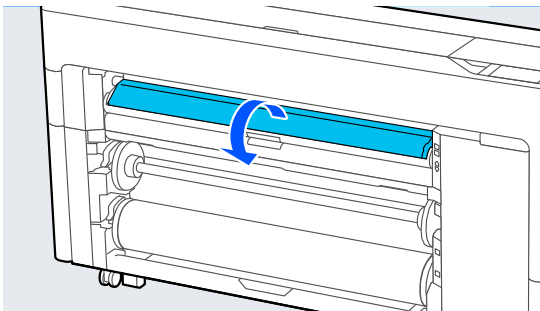
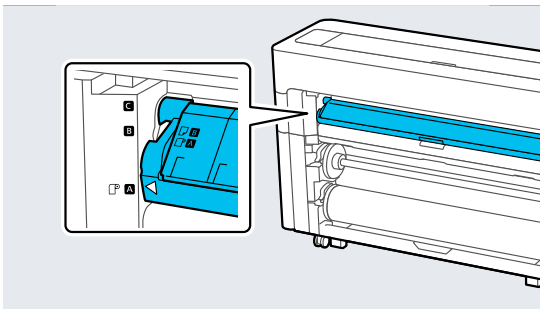
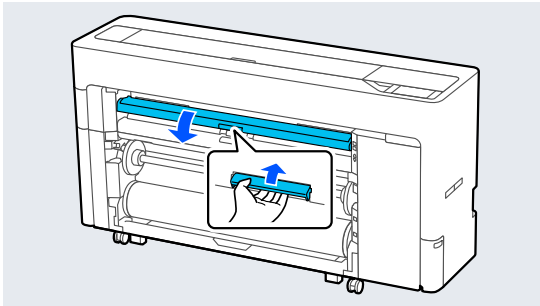

- 17** Set the paper support to the position shown in the illustration.

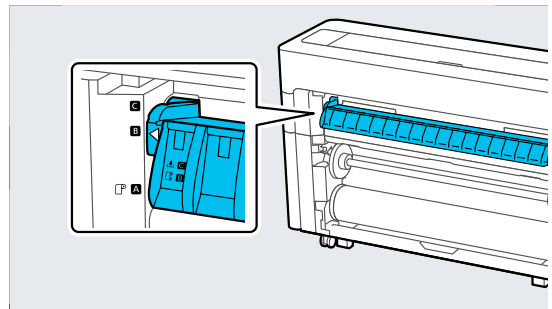
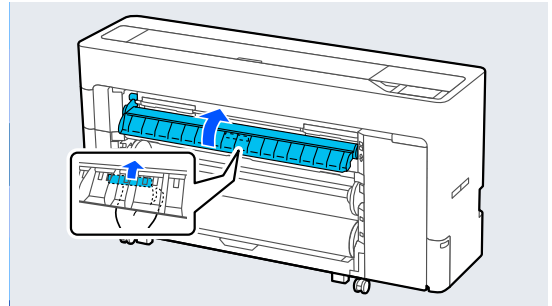

- 18** On the control panel, press **OK** to feed the paper to the take-up position.

- 19** Use **Backward** and **Forward** to adjust the length of paper required for the take-up loading.

- 20** Cut the leading edge of the paper as shown.

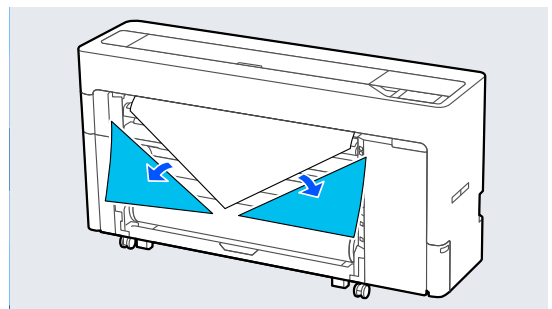
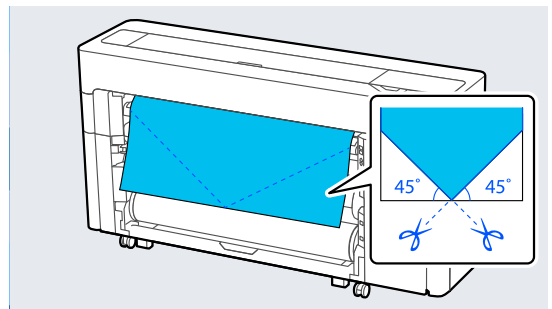

## Basic Operations

- 21** Check the take-up direction and attach the end of the paper to the roll core.

Printed side out

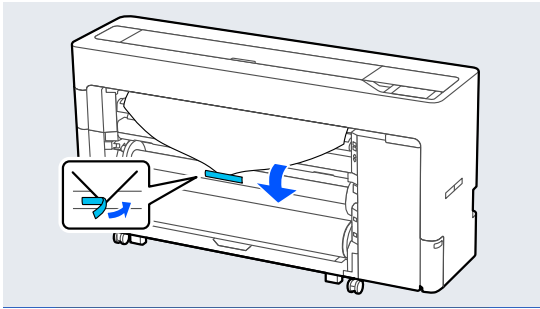

Printed side in

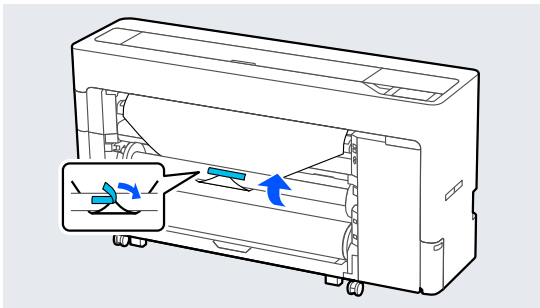

- 22** Press and hold **Forward** on the control panel to feed the roll paper about one revolution of the take-up roll core.

- 23** Press and hold the Manual take-up button to wind the roll paper once around the roll core.

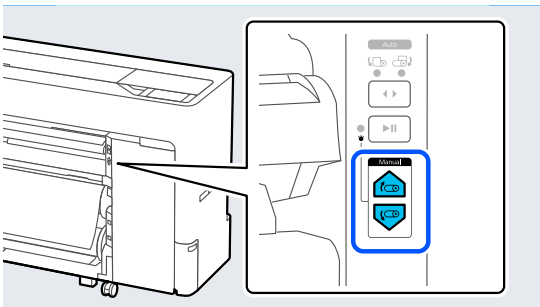

- 24** Press **Complete**.

## Removing Method for Auto Take-up

- 1** Select **Paper Setting - Roll 2 - Feed/Cut Paper** and adjust the cutting position to cut the roll paper.

- 2** Take-up the cut paper.

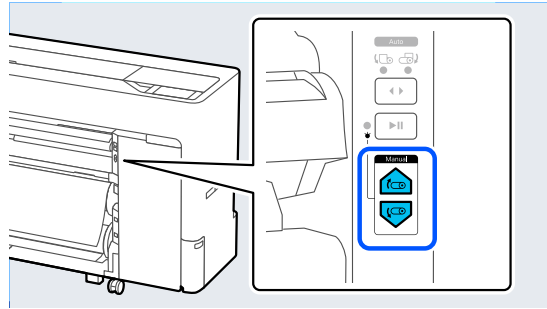

- 3** Raise the spindle lock lever for roll 1.

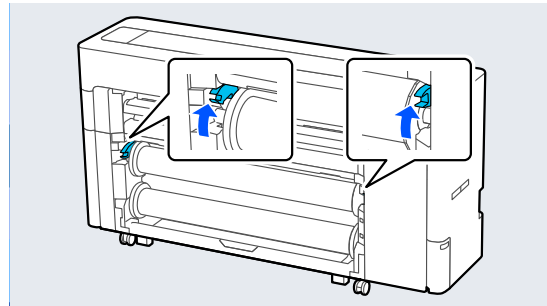

- 4** Remove the spindle.

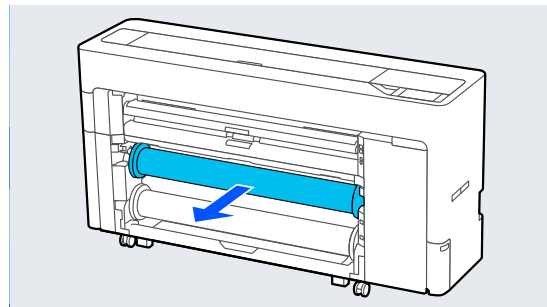

- 5** Remove the transparent media edge guide from the spindle.

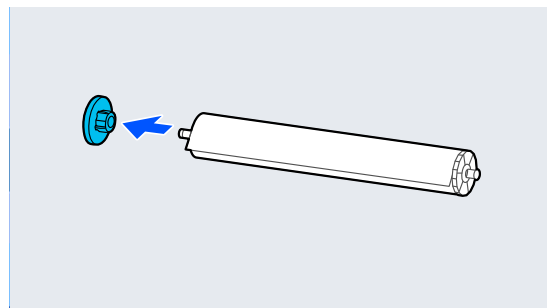

## Basic Operations

- 6** Remove the roll paper that has been taken-up from the spindle.

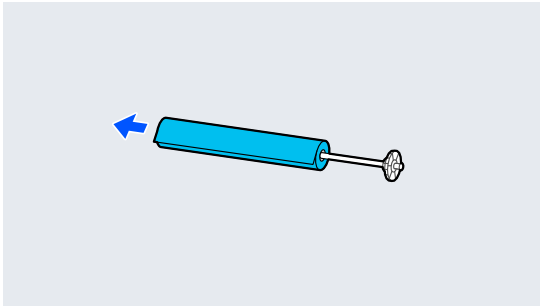

- 7** Attach the rim of the media edge guide to the end.

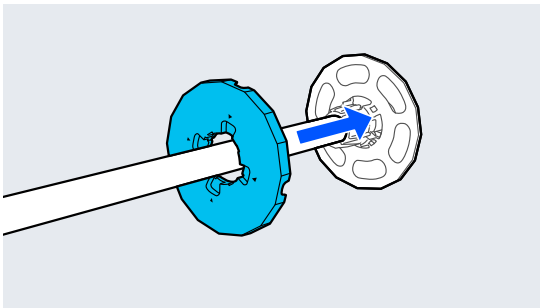

- 8** Attach the transparent media edge guide to the spindle.

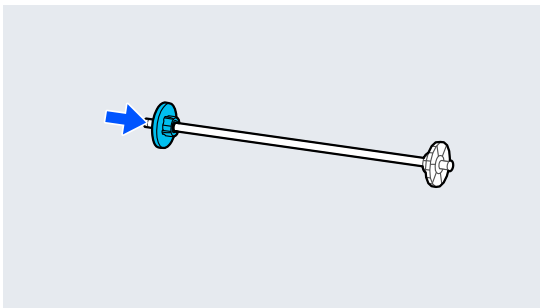

- 9** Place the spindle into the grooves with the black media edge guide on the right.

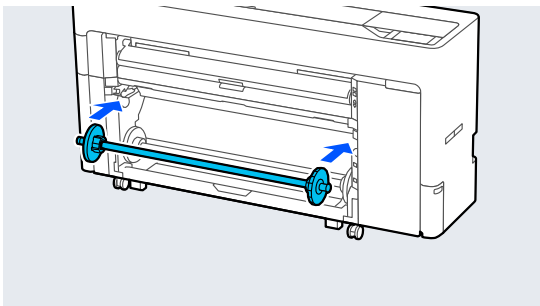

- 10** Lower the spindle lock lever.

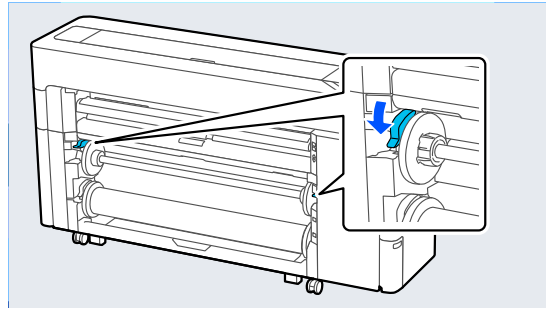

## Basic Operations

# Basic Printing Methods (Windows)

Printing is performed from the software that created the data to be printed. The following explains the basic operating procedure for printing.

- 1 Turn on the printer, and load the paper.  
 ➤ “Loading and Removing the Roll Paper” on page 42  
 ➤ “Loading and Removing Cut Sheets/Poster Board” on page 50

- 2 When you have created the data, click **Print** in the **File** menu.

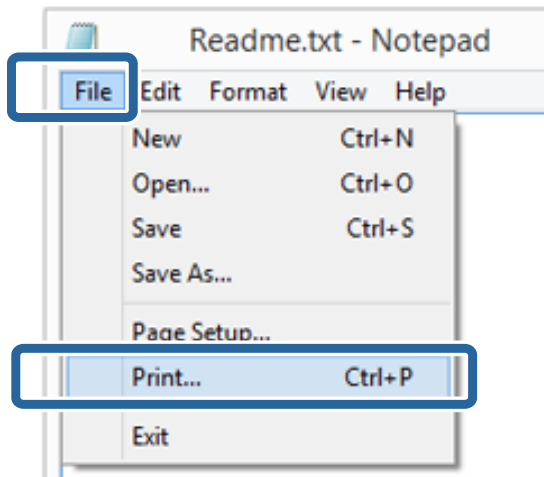

- 3 After confirming that the printer is selected, click **Printer properties** or **Properties** to display the Printer Settings screen.

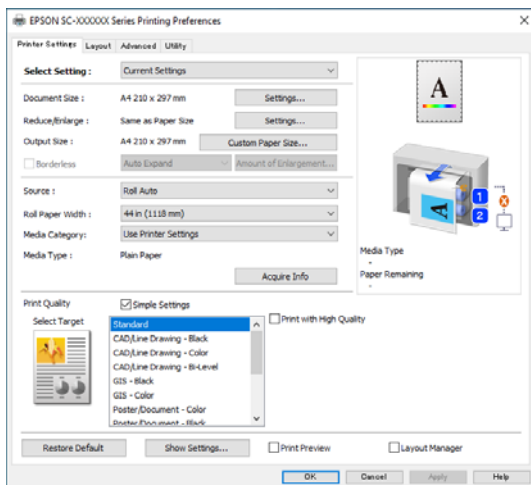

- 4 Set **Page Size**. Set the paper size set when creating the print data in the software.

Set the **Paper Size** and **Reduce/Enlarge** according to the loaded paper.

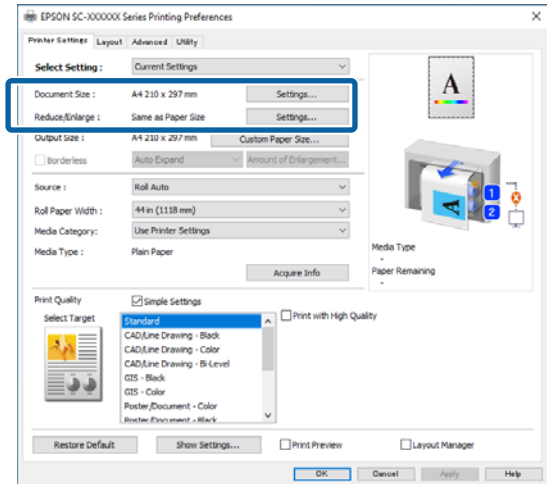

- 5 Set the **Output Size** according to the paper loaded in the printer.

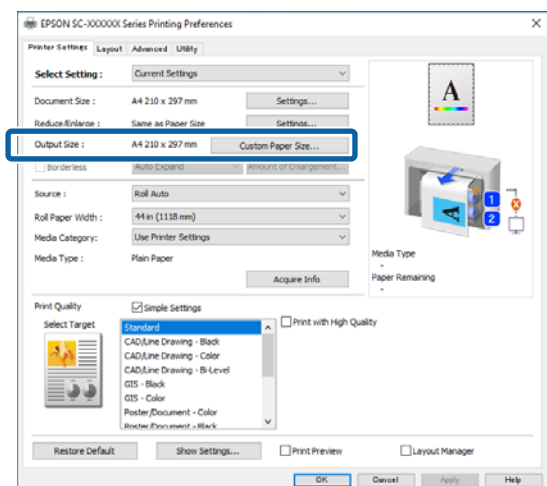

- 6 Make the borderless settings.  
To print without a border (margin), select **Borderless**.

## Basic Operations

Set the expansion and the amount of enlargement as necessary.

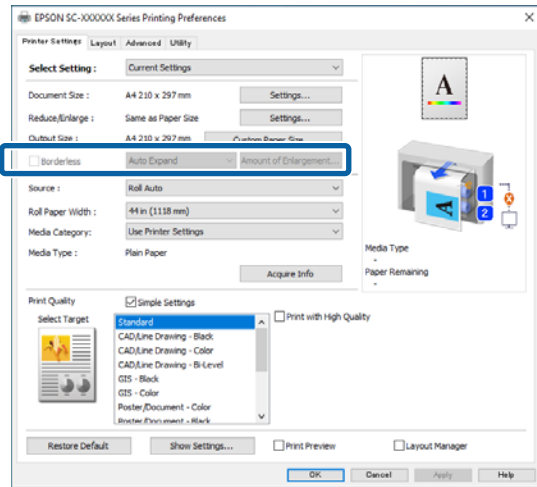

**Note:**

Depending on the paper, borderless printing may not be supported, in which case you cannot perform borderless printing.

**7** Set the **Source**, **Roll Paper Width**, **Media Category**, and **Media Type**.

Click **Acquire Info** to display information of the paper loaded in the printer.

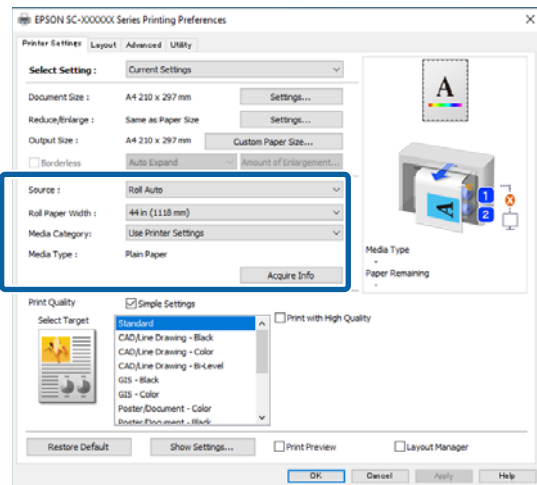

**8** Set the print quality. Set **Select Target**.  
**SC-P Series**

Select **Select Target**. Set the **Print Mode**, **Color Mode**, and **Level** as necessary.

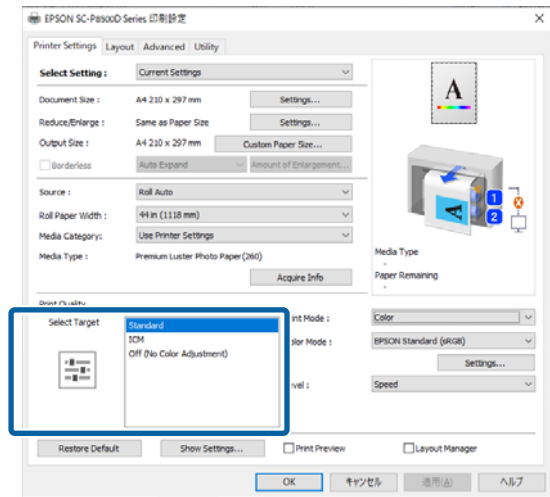

**SC-T Series**

Select **Simple Settings** as necessary.

When printing in high quality, select **Print with High Quality**.

To make detailed print quality settings, clear **Simple Settings**.

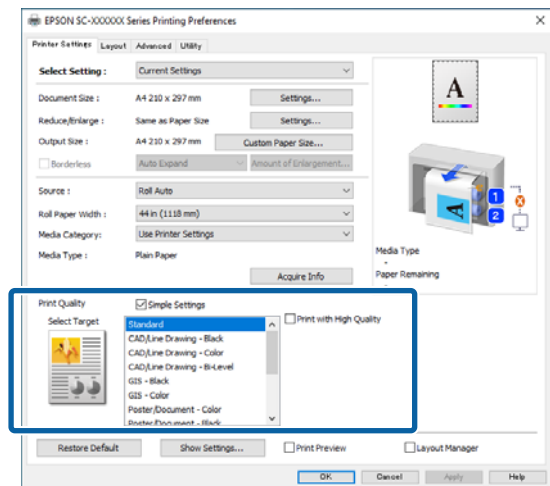

## Basic Operations

**9** Check the content of the settings.

The settings are reflected in the illustration on the right, so check this to make sure everything is correct.

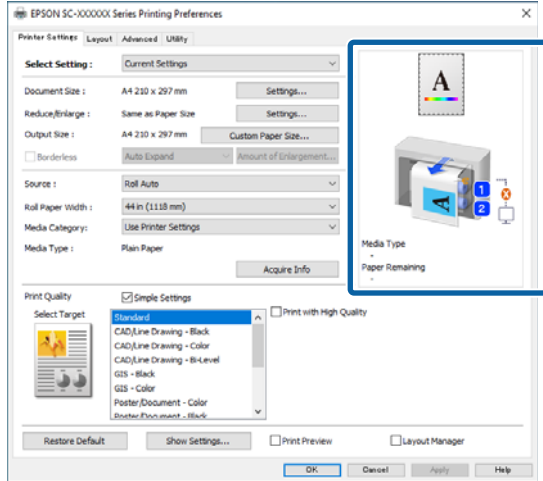

**10** Click the **OK** button.

**11** When settings are complete, click **Print**.

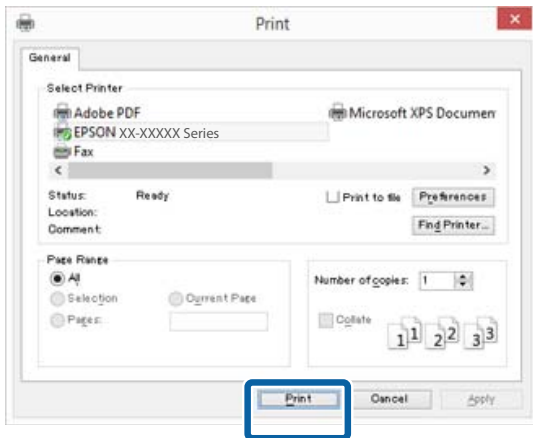

The progress bar is displayed, and printing starts.

### Screen while printing

The following screen is displayed when you start printing, and the progress bar (the computer's processing status) is displayed. On this screen you can check the remaining ink level, product numbers for the ink cartridges, and so on.



An error message is displayed if an error occurs or an ink cartridge needs replacing while printing.



## Basic Operations

# Basic Printing Methods (Mac)

- 1 Turn on the printer, and load the paper.  
 ↗ “Loading and Removing the Roll Paper” on page 42  
 ↗ “Loading and Removing Cut Sheets/Poster Board” on page 50
- 2 When you have created the data, click **Print** and so on from the **File** menu of the application.

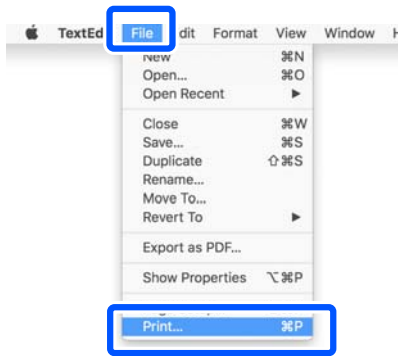

- 3 Click **Show Details** at the bottom of the screen.

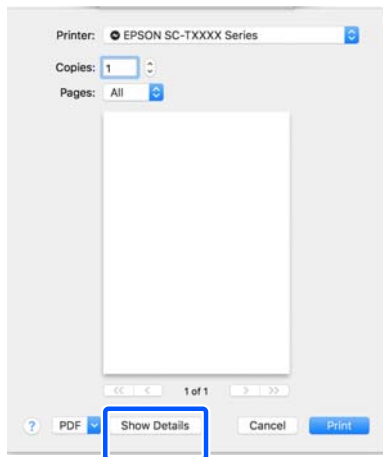

For Mac OS X v10.6 and v10.5, click the arrow (▼) on the page settings screen to set the items.

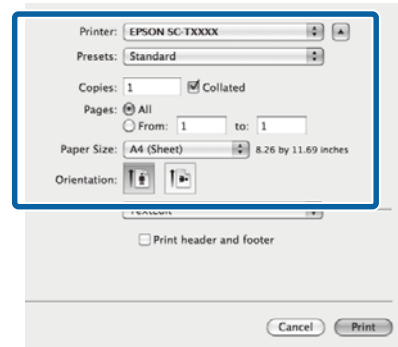
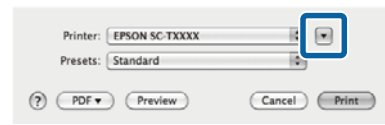

**Note:**

If page settings are not displayed in the print screen, click the “page settings” option (for example, **Page Setup**) in the **File** menu.

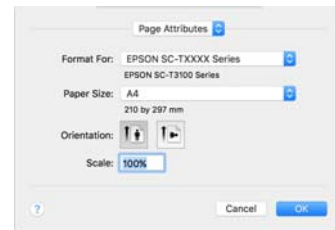

- 4 Check that this printer is selected, and then set the paper size.

In **Paper Size**, set the paper size, borderless printing method, and the paper source.

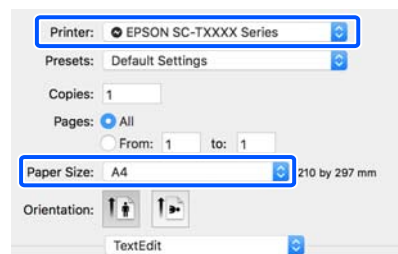

## Basic Operations

- 5 Select **Printer Settings** from the list, and then check the print paper settings.

When **Auto** is selected for Roll Switching when the printer driver is opened, the paper type and width for the roll paper currently being used by the printer are selected. When performing printing, the roll paper to be printed is switched according to the **Auto** setting from the printer's **General Settings - Printer Settings - Paper Source Settings - Roll Paper Setup - Roll Switching** menu.

 [“Automatically Switch Roll Paper for Printing \(Except for the SC-P6500E Series/SC-T3700E Series\)” on page 91](#)

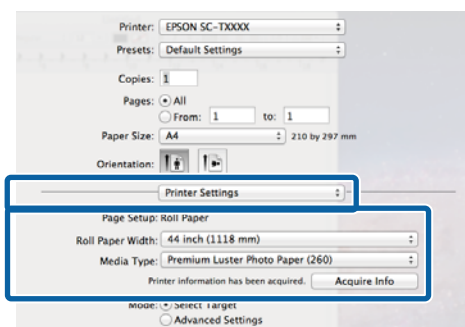

If the displayed content is not what you want, change the printer paper to the paper you want to use, and then click the **Acquire Info** button. The printer information is reacquired and the settings are updated.

- 6 Select the intended use of the printed material. Choose an option according to the type of document and how it will be used.

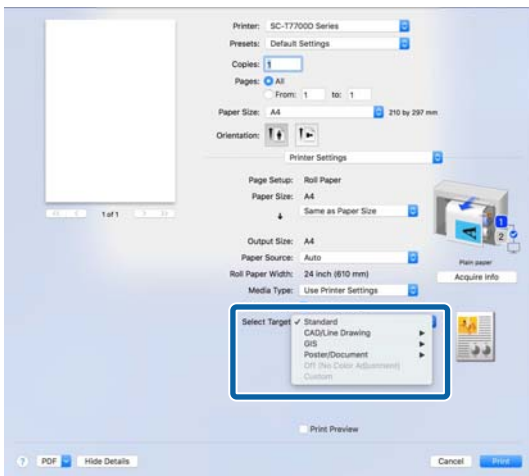

To set the color correction method or color adjustments in detail to match your preferences, select **Advanced Settings** as the **Mode Settings**.

- 7 Check the content of the settings. The settings are reflected in the illustration on the right, so check this to make sure everything is correct.

- 8 When settings are complete, click **Print**.

The printer icon is displayed in the Dock while printing. Click the printer icon to display the status. You can check the progress of the current print job and the printer status information. You can also cancel a print job.

Also, if an error occurs while printing, a notification message is displayed.

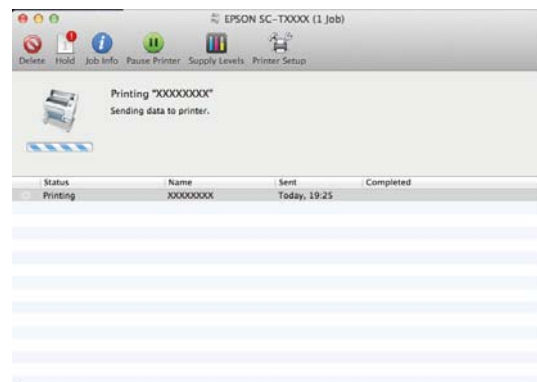

## Basic Operations

### Printable area

This section describes the printable areas for the printer.

If the margin set in an application is larger than the following setting values, sections beyond the specified margins are not printed. For example, if 15 mm is selected for the left and right margins in the printer menus and the document fills the page, the 15 mm at the left and right sides of the page will not be printed.

### Roll Paper Printable Area

The gray area in the illustration below shows the printable area.

When printing borderless on the left and right, the left and right margins are 0 mm. When printing borderless on all sides, the margins for all sides are set to 0 mm.

The arrow in the illustration indicates the direction that the paper is ejected.

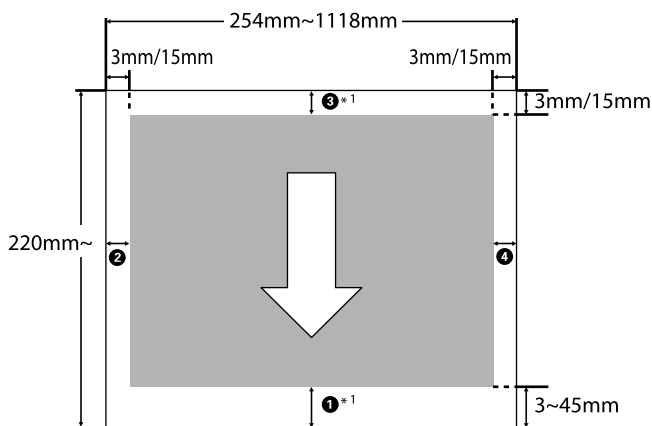

\*1 If you select **Save Roll Paper** as the **Roll Paper Option** on the **Advanced** tab in the printer driver, the top and bottom margins of the paper are set to 0 mm.

① to ④ in the illustration represent the top, bottom, left, and right margins.

When performing borderless printing, the following values are set to 0 mm.

- When performing left/right borderless printing: ②, ④

- When performing borderless printing for all edges: ①, ②, ③, ④

Otherwise, the margins depend on the setting value of the **Top/Bottom Margins** in the menu.

**Top/Bottom Margins** setting  [“Paper Setting” on page 138](#)

The initial default values are 3 mm/15 mm.

#### **Important:**

- Printing is distorted when the trailing edge of the roll paper comes off the core. Make sure the trailing edge does not come inside the printing area.*
- Even if the margins change, the printed size does not change.*

Premium Glossy Photo Paper (250)/Premium Semigloss Photo Paper (250)/Premium Luster Photo Paper (260)/Premium Semimatte Photo Paper (260)

Also, when printing the following paper in **CAD/Line Drawing** mode, the values for ① and ③ are 3 mm.

Singleweight Matte Paper

### Cut Sheets Printable Area

When printing borderless on the left and right, the left and right margins are 0 mm. (Borderless printing is not available with poster board.)

The arrow in the illustration indicates the direction that the paper is ejected.

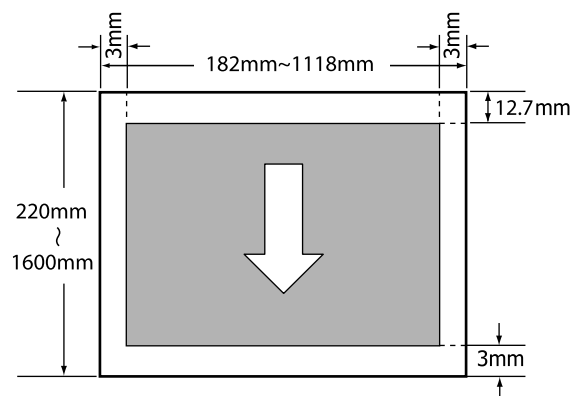

## Basic Operations

# Turning Off the Power Using Power Off Timer

The printer offers the following two power management options.

### ❑ Sleep mode

The printer enters sleep mode when there are no errors, no print jobs being received, and no control panel or other operations performed. When the printer enters sleep mode, the control panel's screen turns off and the internal motors and other parts switch off to consume less power. Sleep mode is cleared if a print job is received or a button on the control panel is pressed.

You can set the time before entering sleep mode by selecting from 1 to 120 minutes. At default settings, the printer enters sleep mode if no operations are performed for 15 minutes. The time before entering sleep mode can be changed in the General Settings menu. [☞ “General Settings” on page 147](#)

#### Note:

When the printer enters sleep mode, the control panel's screen goes blank as if the power has been turned off, but the  light remains on.

### ❑ Power Off Timer

The printer is equipped with a Power Off Timer option that automatically turns the printer off if no errors occur, no print jobs are received, and no control panel or other operations are performed for a set period of time. You can set the time until the printer automatically turns off from 30 minutes to 12 hours.

The factory default setting is **Off**. You can perform **Power Off Timer** from the **General Settings** menu.

[☞ “General Settings” on page 147](#)

## About Power Management

You can adjust the time before Power Management is applied. Any increase will affect the printer's energy efficiency. Please consider the environment before making any changes.

# Canceling Printing

There are a few ways to stop printing operations depending on the situation.

When the computer has finished sending data to the printer, you cannot cancel the print job from the computer. Cancel on the printer.

## Canceling from a Computer (Windows)

### When the Progress Bar is displayed

Click **Cancel Printing**.

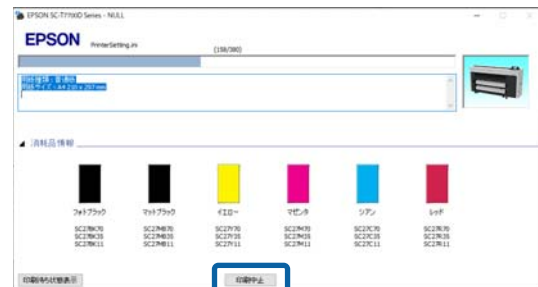

### When the Progress Bar is not displayed

1

While printing, click the printer icon displayed on the taskbar.

Whether or not an icon is displayed depends on the settings selected for Windows.

2

Right-click on the print data name you want to cancel to display the document menu, and then click **Cancel**.

To cancel all print data, click **Cancel All Documents** in the **Printer** menu.

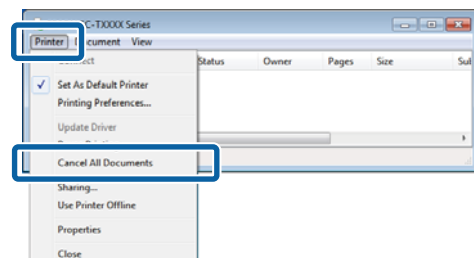

If the job has been sent to the printer, print data is not displayed on the above screen.



## Adobe® PostScript® 3™ Expansion Unit

# Adobe® PostScript® 3™ Expansion Unit

The Adobe® PostScript® 3™ expansion unit is equipped as standard. (Not included with some models.)

The Adobe® PostScript® 3™ expansion unit allows you to output without replacing fonts as it comes with the fonts installed in Windows and Mac.

You can also use the PS Folder function to print files such as PDF and EPS without using another application. Use the PS driver when printing using the Adobe® PostScript® 3™ expansion unit.

For details on using the Adobe® PostScript® 3™ expansion unit, see the "Installing the Software" sheet supplied. See the CD supplied for the operating instructions.

## When Printing Using the Adobe® PostScript® 3™ Expansion Unit Fails or is Interrupted

You cannot print using the Adobe® PostScript® 3™ expansion unit in the following cases.

- **If the print width exceeds the width of the printer.**

Change the input data or the print settings so that the print width fits the width of the printer.

Enabling Auto Rotate may also solve the problem.

- **If an unsupported paper type is selected.**

Check the paper type, and then try printing again.

- **If the print data has been corrupted.**

If this occurs, check the print data. Correct the data if necessary.

- **If the print data is too complicated to process.**

If this occurs, try lowering the PDF rendering level in **Printer Settings - PS Settings**. (Only when printing PDF files)

- **The file size of the print data exceeds the maximum limit.**

Make sure the file size is 2 GB or less.

**Note:**

*If a problem occurs, enable PS Error Sheet printing from **Printer Settings - PS Settings** to print details of the error.*

## Using the SSD Unit (Optional)

# Using the SSD Unit (Optional)

By connecting the optional SSD Unit, you can store documents on the SSD and view, print, or output them as files when needed.

Installed as standard for the SC-P8500DM Series/SC-T7700DM Series/SC-T5700DM Series. You can also save scanned data.

 [“Scan \(SC-P8500DM Series/SC-T7700DM Series/SC-T5700DM Series Only\)” on page 134](#)

The space for storing data is called "Storage". Storing frequently used data in Storage means that you can quickly and easily print without using a computer.

### **Important:**

*Data in Storage may be lost or corrupted in the following situations.*

- When the disk is affected by static electricity or electrical noise*
- When the disk has been used incorrectly*
- After a malfunction or repair*
- When the disk was damaged by a natural disaster*

*We take no responsibility for any data loss, data corruption, or problems due to any cause, even including those listed above and within the warranty period. Note that we are also not responsible for the recovery of lost or corrupted data.*

### **Note:**

*When removing the SSD Unit, select **General Settings - System Administration - Disable the Optional storage unit.***

Type		Explanation
Shared Storage	Shared Storage (Fixed)	Anyone can store and use documents. You cannot change the Folder Name or set a password. Also, you cannot delete the Storage space.
	Shared Storage	You can create multiple Storage spaces to organize your documents. You can set a password for the Storage to limit storage and use of documents to a select number of users. You can also set a password for each document to restrict access to it.
Personal Folder		When user authentication is enabled, only logged-in users can store and use documents. It is not displayed when other users log in. Users can only have one Personal Folder.

## Using the SSD Unit from the Printer Driver

To use the SSD Unit from the printer driver, you need to make settings on the printer driver screen.

### Windows

**1**

Select Preferences on the Printer Properties screen

## Using the SSD Unit (Optional)

- 2 Select **Acquire from Printer**, and then press **Get**.

If **Option Storage: Available** is displayed in the **Current Printer Information** section, you can use the SSD Unit.

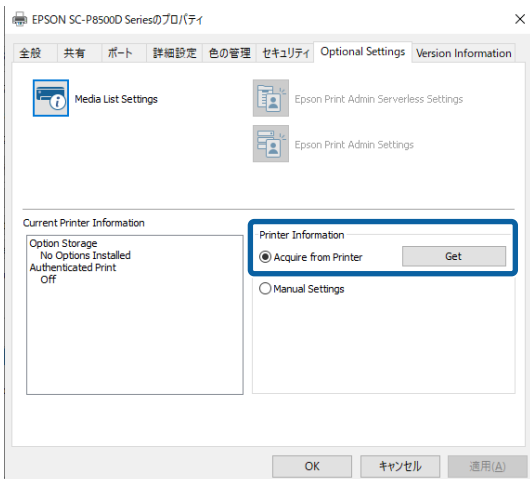

### Mac

- 1 Select **Storage Settings** on the Printer Properties screen.

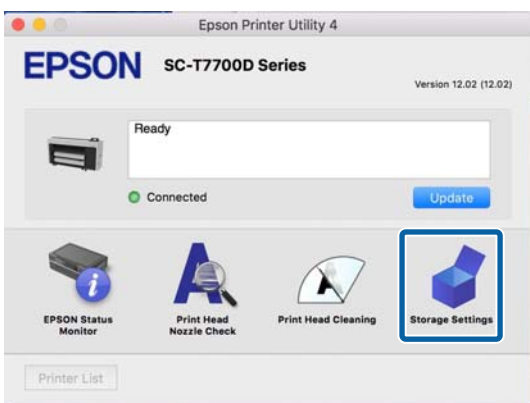

- 2 Make settings on the **Storage Settings** screen.

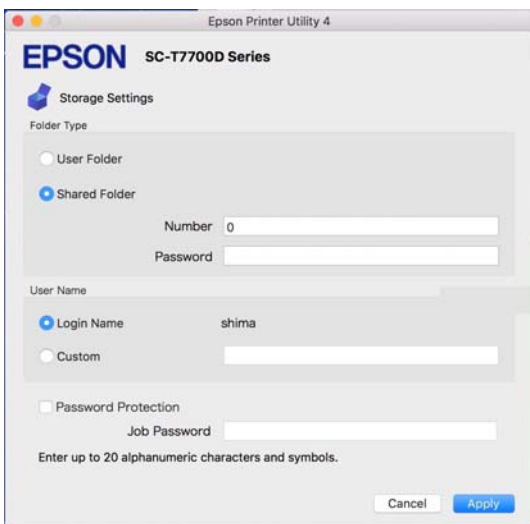

You can now use the SSD Unit.

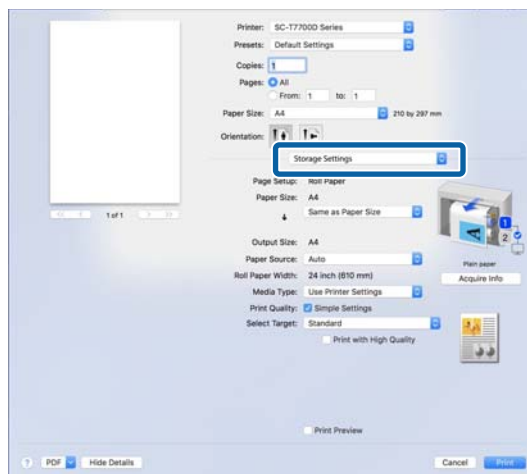

## Creating a Storage Space

An administrator or a user can create a shared Storage space. However, users can only create Storage spaces when **Menu - General Settings - Storage Settings - Shared Folder Access Control - Access** is set to **Allowed** and **Operation Authority** is set to **User**.

You cannot create a **Personal Folder**.

- 1 Select  on the printer's control panel.

- 2 Enter a value for each item on the Storage Settings screen.

- Storage number:**  
If no number is entered, it will be assigned automatically.
- Folder Name (required item):**  
Enter a name within 30 characters.
- Storage Password:**  
Set this to restrict the use of the Storage space with a password. Once this has been set, you will be required to enter a password to save documents to Storage, view documents in Storage, and perform Storage operations.
- Automatic File Deletion Settings:**  
Set whether or not to automatically delete saved documents.

## Using the SSD Unit (Optional)

# Saving Data to Storage

## Saving a Document from your Computer to Storage (Windows)

When printing a document from the printer driver, you can select the Storage where you want to store it. You can also save the print data to Storage without printing the document.

**1** In the printer driver, open the **Advanced** tab.

**2** Select **Save to Storage and Print** from **Job Type**.

**Note:**

Select **Save to Storage** from **Job Type** if you want to save the print data to Storage without printing the document.

**3** Click **Settings**.

**4** If the folder name you want to save to is not displayed in **Folder Name** on the Storage Settings screen, click **Storage Settings**, add the folder name in **Folder List (Printer)**, and then click **OK**.

**Note:**

If the folder name you want to save to is not displayed in **Folder List (Printer)**, click **Update Folder List** and wait for the update to complete.

**5** Select the folder name you want to save to from **Folder Name** on the Storage Settings screen.

**Note:**

If you do not know the **Password**, contact your administrator.

**6** Set other items as necessary, and then click **OK**.

**7** If you want to change the resolution of the print data when saving to Storage, click the **Printer Settings** tab - **Print Quality** - **Advanced Settings**, set the print quality on the Quality Options screen, and then click **OK**.

**8** Set each item on the **Printer Settings** tab and the **Advanced** tab, and then click **OK**.

**9** Click **Print**.

## Saving a Document from your Computer to Storage (Mac)

When printing a document from the printer driver, you can select the Storage where you want to store it. You can also save the print data to Storage without printing the document.

**1** Click **Storage Settings** on the printer driver's Epson Printer Utility screen.

**2** Set the save location, and then click **OK**.

**3** Select **Print Settings** from the pop-up menu on the printer driver screen.

**4** Select **Save to Storage and Print** as the printing method.

**Note:**

Select **File Storing** as the printing method if you want to save the print data to Storage without printing the document.

**5** Set other items as necessary.

**6** Click **Print**.

## Saving Data from a Memory Device to Storage

You can save data at the same time as printing. You can also just save data.

**1** Connect the memory device to the printer's USB memory port.

**2** Select **Memory Device** on the Home screen.

## Using the SSD Unit (Optional)

- 3 Select the type of data you want to save, and then select a file.
- 4 Select the **Advanced** tab, and then select **File Storing**.
- 5 Set **File Storing** to **On**.
- 6 Specify the Storage, and then change the other settings as necessary.

**Note:**

*In **Setting**, select whether you want to print the file at the same time as saving it to Storage.*

- 7 Tap .

## Using Data Saved to Storage

### Printing Data in Storage

- 1 Select **Storage** on the printer's control panel.
- 2 Select the Storage space where the document you want to print is stored, and then select **Open**.
- 3 Select the file.
- 4 Set the number of copies you want to print.
- 5 Make print settings as necessary.
- 6 Tap .

## Managing Storage Spaces and Documents

### Searching for Storage Spaces and Documents

You can use the following keywords to search for Storage spaces and documents.

- When searching for a Storage space: Storage Number or Folder Name
- When searching for a document: Document Name or User Name

- 1 Select **Storage** on the printer's control panel.
- 2 Enter a keyword in the search box on the Storage list screen.

To search for a document, search in the same way on the Document list screen.

### Deleting a Document from Storage

- 1 Select **Storage** on the printer's control panel.
- 2 Select the Storage space containing the document you want to delete, and then select **Open**.
- 3 Select the document, and then select **Delete**.

You can also select multiple documents and delete them all at once.

### Changing the Storage Period or Setting to Indefinite

Documents in Storage are not automatically deleted by default.

## Using the SSD Unit (Optional)

The administrator or user can change the storage period or set it to indefinite. However, users can only change this setting when **Menu - General Settings - Storage Settings - Shared Folder Access Control - Access** is set to **Allowed** and **Automatic Delete Setting Authority** is set to **User**.

- 1 Select **Menu** on the printer's control panel.
- 2 Select **General Settings - Storage Settings - Shared Folder File Management**.
- 3 Change the storage period.

---

## Deleting a Storage Space

An administrator or a user can delete a shared Storage space. However, users can only delete Storage spaces when **Menu - General Settings - Storage Settings - Shared Folder Access Control - Access** is set to **Allowed** and **Operation Authority** is set to **User**.

- 1 Select **Storage** on the printer's control panel.
- 2 Select the Storage space you want to delete, and then select **Delete**.
  - If a password has been set for the Storage space, you will need to enter the password. However, administrators can delete without entering the password.
  - You cannot delete a Storage space that contains a document with a password. However, administrators can still delete the Storage space.
  - When you delete a Storage space, all of the documents in that Storage are also deleted.

---

## Restricting Operations for Shared Storage Spaces

Set whether to allow only administrators or other users to operate shared Storage spaces.

- 1 Select **Menu** on the printer's control panel.

- 2 Select **General Settings - Storage Settings - Shared Folder Access Control - Operation Authority**.

- 3 Select **User** or **Administrator Only**.

## Various Printing Methods

# Various Printing Methods

## Enlargements and Horizontal and Vertical Banners

The printer driver can enlarge or reduce documents for different paper sizes. There are three setting methods.

Before printing at non-standard sizes, including vertical or horizontal banners and documents with equal sides, enter the desired paper size in the printer driver.

[“Printing at Non-Standard Sizes” on page 88](#)

- Fit to Roll Paper Width**  
Automatically enlarges or reduces the image size to fit the roll paper width.



- Specify Size**  
You can specify the enlargement or reduction ratio. Use this method for a non-standard paper size.

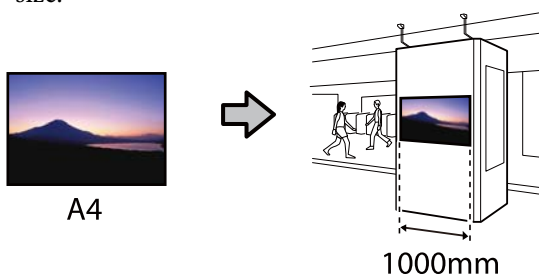

- Fit to Output Size**  
Automatically enlarges or reduces the image size to fit the paper size.

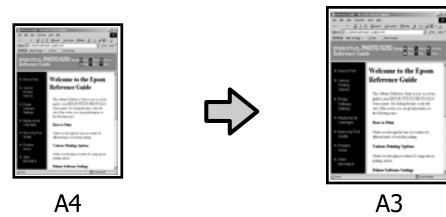

## Fitting Documents to the Width of the Roll Paper

### Settings in Windows

- 1 Display the printer driver's Printer Settings screen, and then set the same paper size as the data's paper size in **Page Size**.

[“Basic Printing Methods\(Windows\)” on page 70](#)

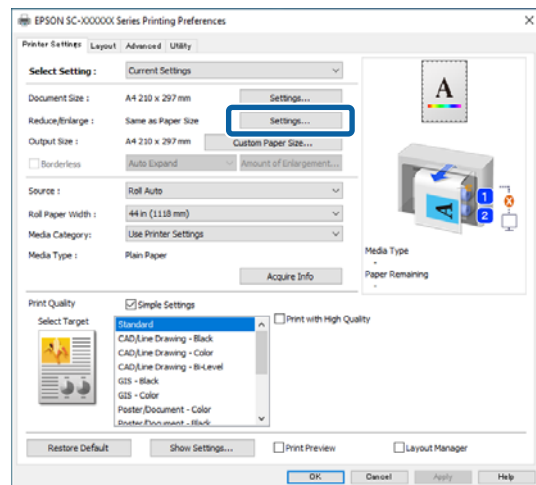

## Various Printing Methods

### 2 Select Settings - Fit to Roll Paper Width.

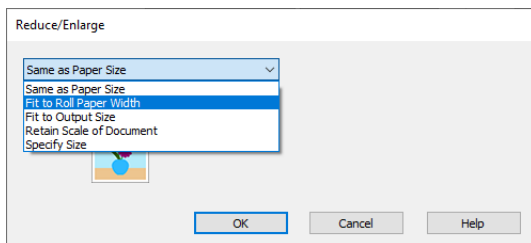
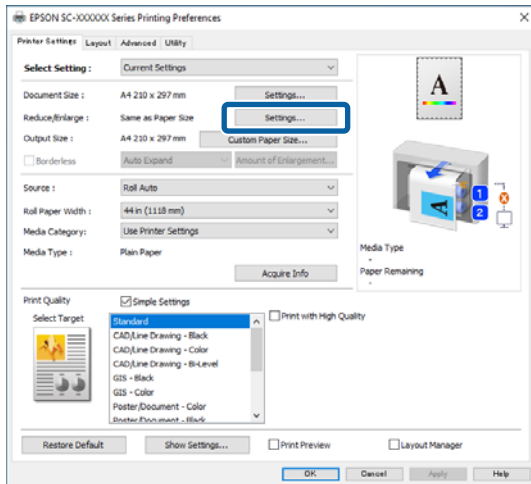

### 3 Select Fit Short Side to Roll Paper Width or Fit Long Side to Roll Paper Width.

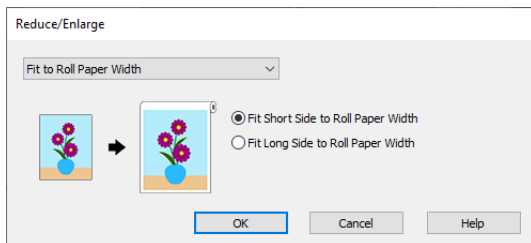

### 4 Check other settings, and then start printing.

#### Settings in Mac

### 1 Display the Print screen, select **Page Layout Settings** from the list, and then select **Reduce/Enlarge**.

[“Basic Printing Methods\(Mac\)” on page 73](#)

### 2 Select **Fit to Roll Paper Width**, and then select whether to fit the short side of the document to the roll paper width or fit the long side to the roll paper width.

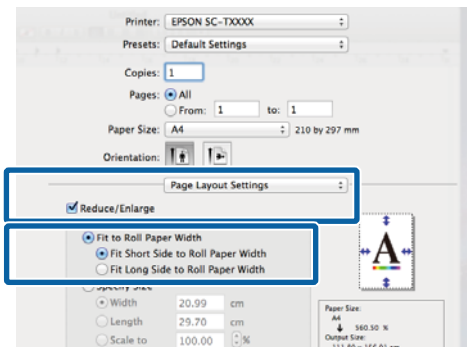

### 3 Check other settings, and then start printing.

## Choosing a Print Size

#### Settings in Windows

### 1 Display the printer driver's Printer Settings screen, and then set the same paper size as the data's paper size in **Page Size**.

[“Basic Printing Methods\(Windows\)” on page 70](#)

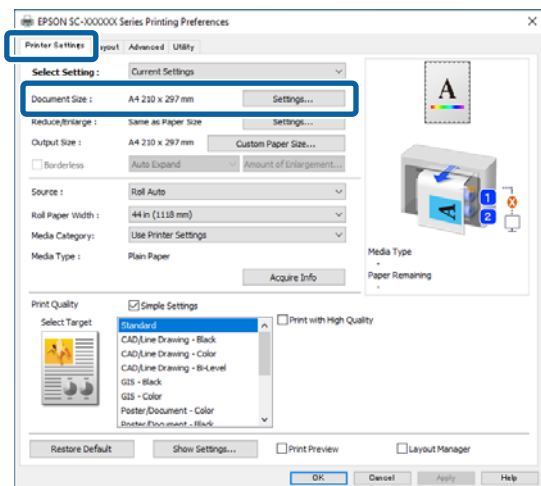

## Various Printing Methods

### 2 Select Settings - Specify Size.

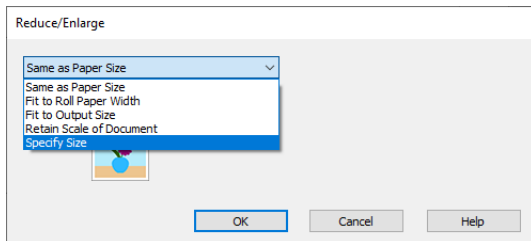
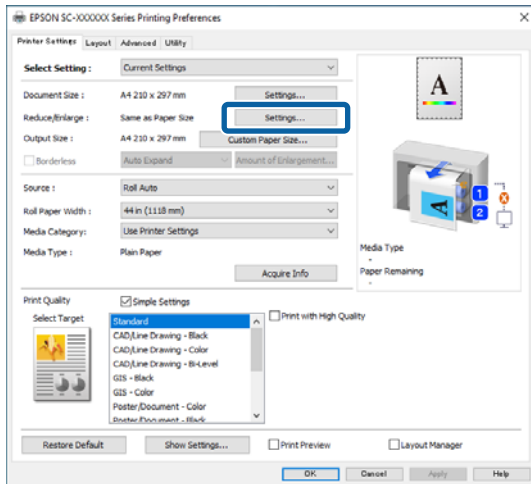

### 3 Set the size.

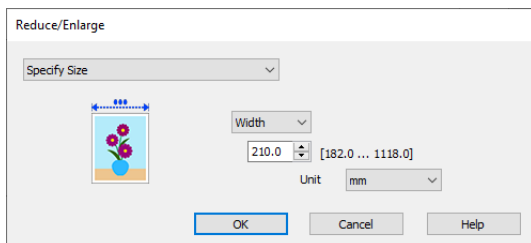

### 4 Check other settings, and then start printing.

#### Settings in Mac

### 1 Display the Print screen, select **Page Layout Settings** from the list, and then select **Reduce/Enlarge**.

[“Basic Printing Methods\(Mac\)” on page 73](#)

### 2 Select **Specify Size**, and then select a size specification method to set the size.

Set a value directly or click the arrows to the right of the scale box to set the value.

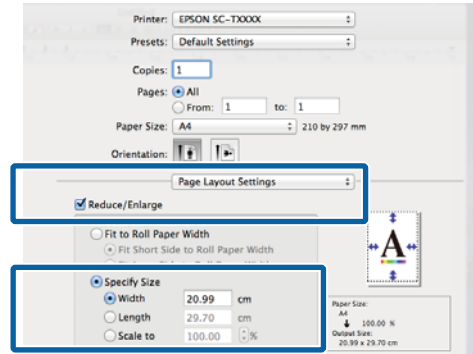

### 3 Check other settings, and then start printing.

## Fitting Documents to the Output Size

#### Settings in Windows

### 1 Display the printer driver's Printer Settings screen, and then set the same paper size as the data's paper size in **Page Size**.

[“Displaying the Settings Screen” on page 122](#)

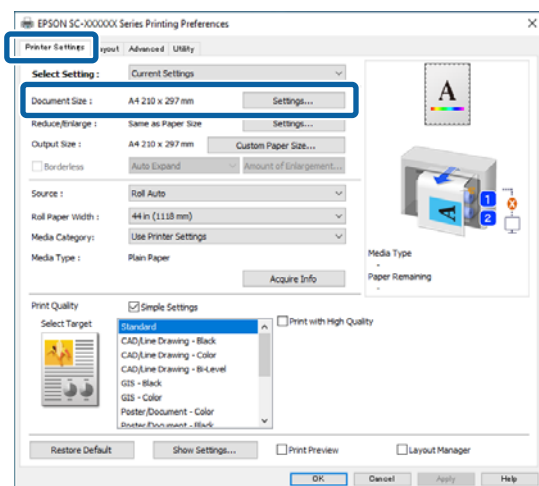

## Various Printing Methods

### 2 Select Settings - Fit to Output Size.

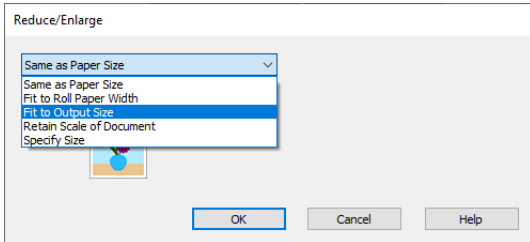

**Note:**

You can also print according to the output size by selecting **Scale to fit paper size** in the **Paper Handling** section on the print screen.

### 3 Select the paper size for printing.

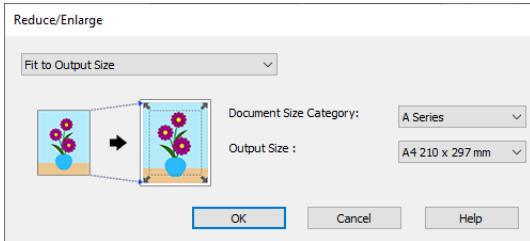

### 4 Check other settings, and then start printing.

#### Settings in Mac

### 1 Display the Print screen, select **Page Layout Settings** from the list, and then select **Reduce/Enlarge**.

📖 [“Basic Printing Methods\(Mac\)”](#) on page 73

### 2 Select **Fit to Output Size**, and then select the size of the paper loaded in the printer.

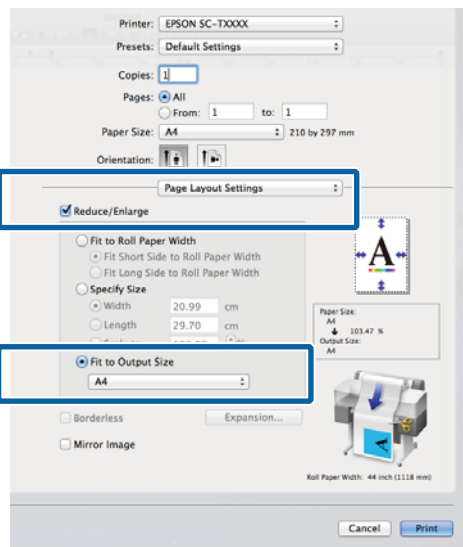

### 3 Check other settings, and then start printing.

## Various Printing Methods

# Printing at Non-Standard Sizes

Before printing at non-standard sizes, including vertical or horizontal banners and documents with equal sides, save the desired paper size in the printer driver. Once they have been saved in the printer driver, custom sizes can be selected in the application Page Setup and other print dialogs.



The following sizes can be used.

Paper Width	182 to 1118 mm
Paper Height	Windows: 205 to 91000 mm Mac OS X: 127 to 15240 mm

### Important:

- The smallest size supported by the printer is 254mm wide × 127mm long. If a smaller size is entered in the printer driver as a **Custom Paper Size...**, the document will print with wider-than-expected margins, which must be trimmed.
- For Mac OS X Custom Paper Sizes, although you can specify a large paper size which cannot be loaded on this printer, it will not be printed properly.
- The available output size is limited depending on the application.

## Settings in Windows

- 1 Display the printer driver's Printer Settings screen, and then click **Custom Paper Size...**

 “Basic Printing Methods(Windows)” on page 70

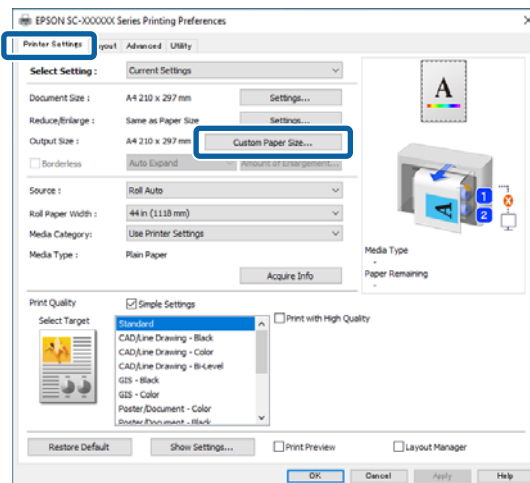

- 2 On the Custom Paper Size... screen, set the paper size you want to use, and then click **Save**.

- Enter the paper name in the **Paper Size Name** field.
- Select a standard size that is close to the size of the paper you want to use in **Base Paper Size** to view its **Paper Width** and **Paper Height** values.
- If you select an aspect ratio in **Fix Aspect Ratio** and select **Landscape** or **Portrait** for **Base**, you can set the size by just entering a value in either **Paper Width** or **Paper Height**.

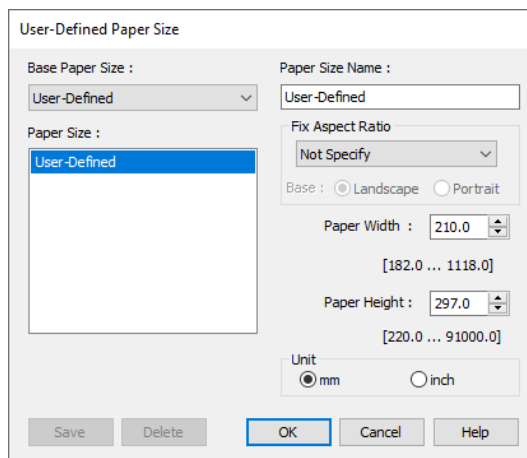

## Various Printing Methods

**Note:**

- To change the paper size you saved, select the paper size name from the list on the left.
- To delete a saved paper size, select the paper size name from the list on the left of the screen and then click **Delete**.
- You can save up to 100 paper sizes.

**3** Click **OK**.

You can now select the new paper size from **Paper Size** on the Printer Settings screen.

You can now print as normal.

### Settings in Mac

**1** Display the Print screen, and then select **Manage Custom Sizes** from the **Paper Size** list.

 [“Basic Printing Methods\(Mac\)” on page 73](#)

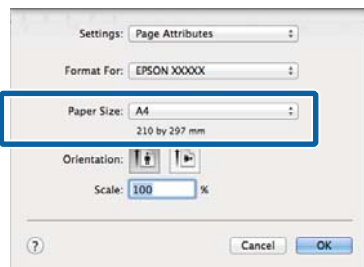

**Note:**

If page setting options are not available in the application's print dialog, display the page settings dialog.

**2** Click **+** and then enter the paper size name.

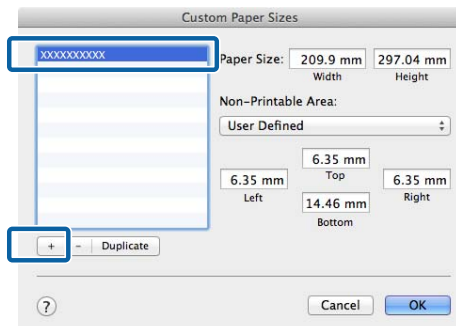

**3** Enter values in **Width** and **Height** for the **Paper Size**, enter the margins, and then click **OK**.

The ranges of page sizes and margin sizes that can be specified differ depending on your printer model and the settings on the printer.

 [“Printable area” on page 75](#)

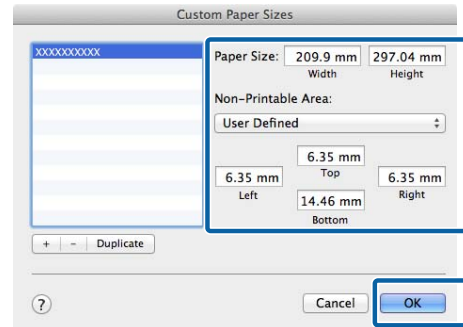

**Note:**

- To edit a saved custom size, choose its name from the list on the left.
- To duplicate a saved paper size, select its name from the list on the left of the screen and click **Duplicate**.
- To delete a saved custom size, select it in the list on the left and click **-**.
- The custom paper size setting differs depending on the operating system version. See your operating system's documentation for details.

**4** Click **OK**.

You can select the paper size you saved from the Paper Size pop-up menu.

You can now print as normal.

## Various Printing Methods

# Printing CAD Drawings

This printer supports HP-GL/2 and HP RTL used for plotter printing. You can use either of the following methods to print CAD drawings on this printer.

- Print using the CAD/Line Drawing mode in the supplied printer driver.
- Print using HP-GL/2 and HP RTL emulation used for plotter printing.

The printer automatically switches between normal printing and HP-GL/2 or HP RTL emulation printing based on the print data it receives. However, if mode switching is not performed correctly and printing is not performed properly, set the **General Settings - Printer Settings - Language - Network** to HP-GL/2.

## Printing Using CAD/Line Drawing Mode in the Printer Driver

When printing CAD drawings from a Windows application, we recommend printing using the CAD/Line Drawing mode in the printer driver.

### Windows

- 1 Display the printer driver's Printer Settings screen, and then make the following settings.

#### SC-P Series

Select **Select Target** in **Print Quality**, and then select **Standard**. In **Print Mode** select **Color**, **Black**, or **Black (Bi-Level)**.

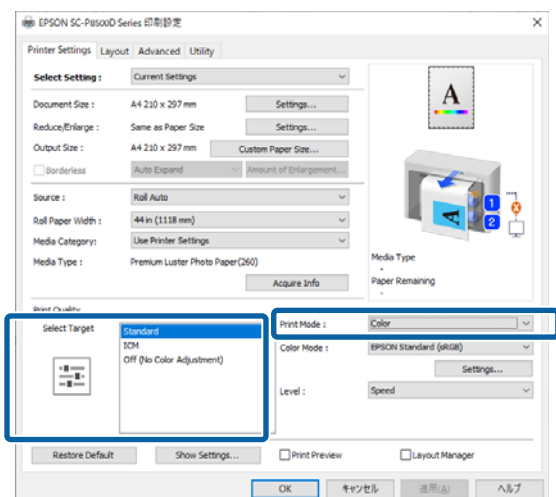

#### SC-T Series

Select **Select Target** in **Print Quality**, and then select **CAD/Line Drawing - Black**, **CAD/Line Drawing - Color**, or **CAD/Line Drawing - Bi-Level**.

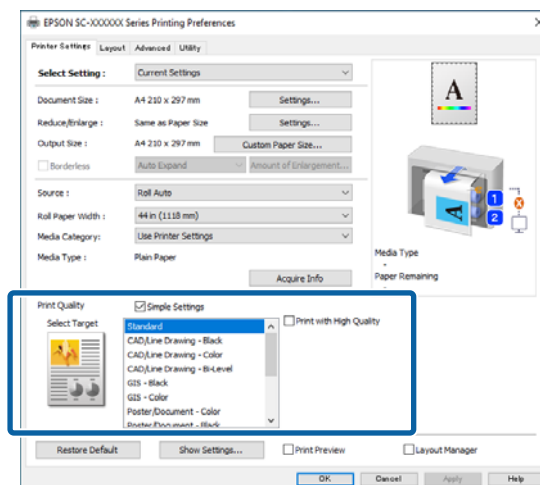

*Note:*  
**CAD/Line Drawing - Black**, **CAD/Line Drawing - Color**, **CAD/Line Drawing - Bi-Level** are displayed as selections in **Select Target** when a suitable paper type for printing CAD drawings is selected.

- 2 Check other settings, and then start printing.

### Mac

- 1 Display the Print screen, and then select **Printer Settings** from the list.

[“Basic Printing Methods\(Mac\)” on page 73](#)

## Various Printing Methods

### 2 Select Line Drawing in Print Quality.

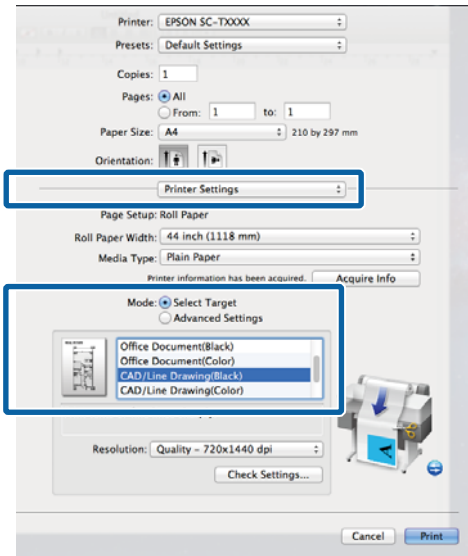

### 3 Check other settings, and then start printing.

## Printing Using HP-GL/2 and HP RTL Emulation

The printer can emulate\* HP-GL/2 (compatible with HP Designjet 750C) and HP RTL.

If you want to print using HP-GL/2 or HP RTL output from your software, set the output device as follows according to your model.

HP Designjet 750C C3196A

\* Not all functions are supported. If you will use an untested application, test its output in advance.

For a list of applications that have been tested, visit the Epson website at <https://www.epson.com>.

#### Important:

*The printer may not perform as expected if the size of the data to be printed is extremely large.*

Keep the following points in mind when printing using HP-GL/2 or HP RTL emulation.

#### HP-GL/2 Settings

When printing using HP-GL/2 and HP RTL emulation, use **Printer Settings - HP-GL/2 Unique Settings** from the printer's **General Settings**.

## Automatically Switch Roll Paper for Printing (Except for the SC-P6500E Series/ SC-T3700E Series)

You can automatically switch to the appropriate roll paper for a print job. The following outlines the conditions and priorities for switching roll paper.

Priority	Item	Content
1	Paper Type	Switch to roll paper that has the same paper type as the print job.
2	Paper Width	Switch to roll paper that has the same or a similar paper width to the print job.
3	Paper Length	Switch to roll paper with less paper remaining.

## Switching Between Roll 1 and Roll 2 According to the Paper Type

If you frequently use the printer as described in the following example, you can make the settings below to automatically switch between Roll 1 and Roll 2 to print according to the paper type.

## Various Printing Methods

### Usage example

When using different paper types for different purposes, such as printing drawings for internal verification on plain paper and printing drawings for presentations or client submission on color printing paper.

The following explanation assumes that the paper is loaded as follows. The width of each paper should be the same.

Roll 1: Plain paper

Roll 2: Singleweight Matte Paper

### Settings on Windows

**1** Select **Menu - General Settings - Printer Settings - Paper Source Settings - Roll Switching - Auto - Paper Type** from the printer's control panel.

**2** Select the **Type Match**.

**Note:**

When **Disable** is selected, printing is performed even if the paper loaded in the printer and the paper type selected in the driver are different.

**3** Display the printer driver's Printer Settings screen, and then select **Roll Auto** as the **Source**.

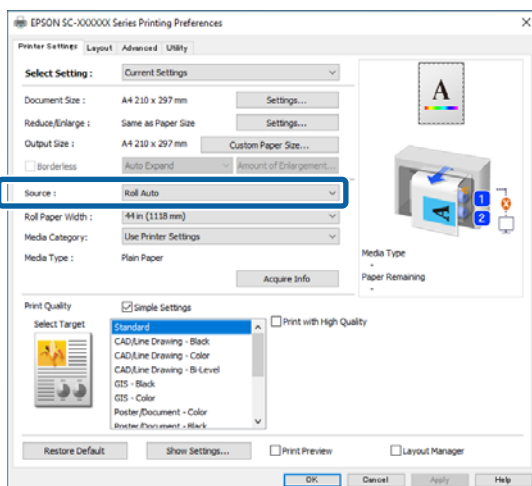

**4** Select the paper type you want to print on in **Media Category - Paper Type**.

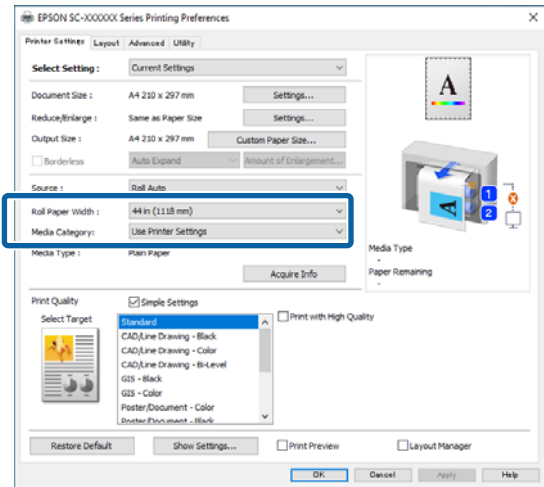

**5** Make any other necessary settings, such as the Page Size and **Print Quality**, and then print.

### Settings in Mac

**1** Select **Menu - General Settings - Printer Settings - Paper Source Settings - Roll Switching - Auto - Paper Type** from the printer's control panel.

**2** Select the **Type Match**.

**Note:**

When **Disable** is selected, printing is performed even if the paper loaded in the printer and the paper type selected in the driver are different.

**3** Display the Print screen on your computer, make sure roll paper is selected as the **Paper Size**, and then select **Printer Settings** from the list.

## Various Printing Methods

- 4** Make sure that **Auto** is displayed for Roll Switching.

If **Auto** is not displayed, click it and select **Auto**.

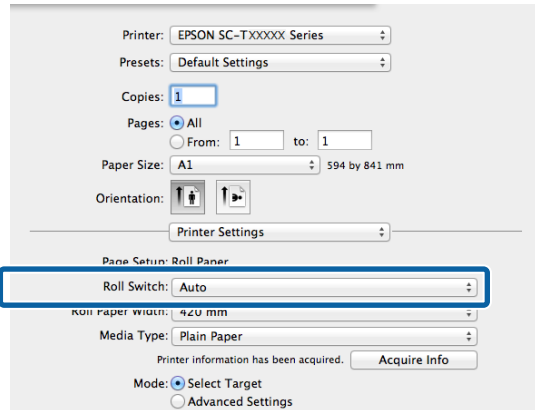

- 5** Select the paper type you want to print on in **Media Type**.

In this example, we will select **Plain paper** or **Singleweight Matte Paper** according to the intended usage.

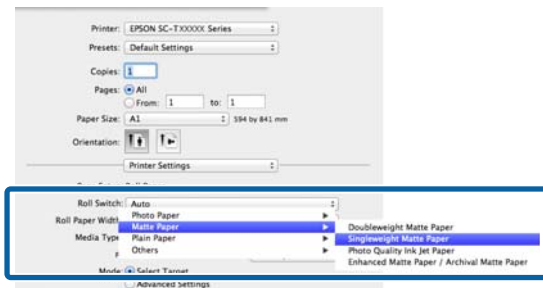

- 6** Make any other necessary settings, such as the **Print Quality**, and then print.

The **Media Type** differs to the setting on the printer. If this message is displayed, click Ignore.

## Switching Between Roll 1 and Roll 2 According to the Page Size

If you frequently use the printer as described in the following example, you can make the settings below to automatically switch between Roll 1 and Roll 2 to print according to the page size of the print job.

### Usage example

When printing drawings at various sizes, such as A0, A1, A2, and A3, by automatically switching to the roll paper with the smaller margins.

The following explanation assumes that the paper is loaded as follows. The paper type should be the same.

Roll 1: A2 wide

Roll 2: A0 wide

### Settings on Windows

- 1** Select **General Settings - Printer Settings - Paper Source Settings - Roll Paper Setup - Roll Switching - Auto - Paper Width** from the printer's control panel.

- 2** Select **Optimize Margins** or **Width Match**.

Select **Optimize Margins** to print on the roll paper with smaller margins.

Select **Width Match** to print on the roll paper with the same paper width as the print job.

**Note:**  
Select **Disable** to print regardless of the paper width.

- 3** Display the printer driver's **Printer Settings** screen, and then select **Roll(Auto)** as the **Source**.

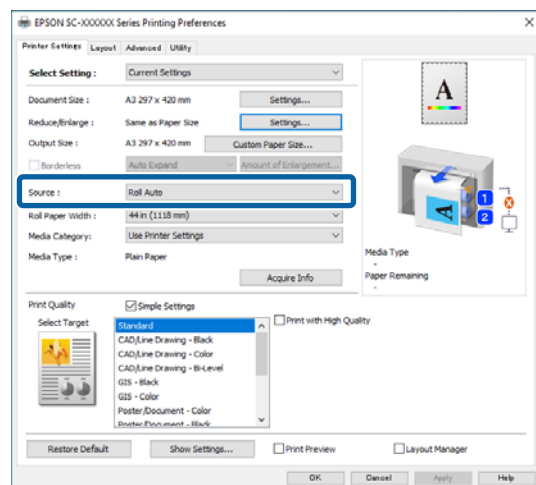

## Various Printing Methods

- 4** For the **Page Size**, set the paper size set in the software.

In this example, we will select **A1 594 x 841 mm**.

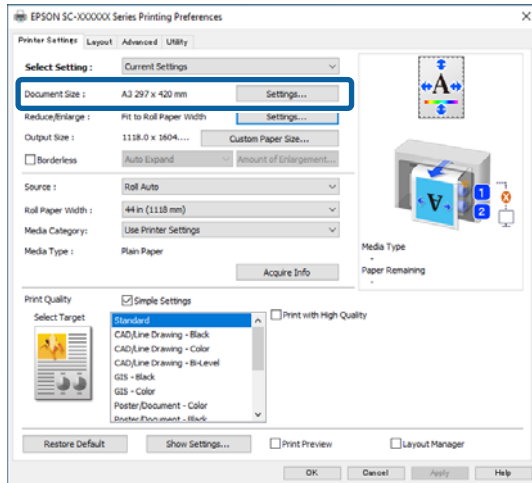

- 5** Make any other necessary settings, such as the **Print Quality**, and then print.

Printing is performed on roll 2 (A0 width) roll paper.

If you select **A3** or **A2** in step 4, printing is performed on roll 1 (A2 width) roll paper.

### Settings in Mac

- 1** Select **General Settings - Printer Settings - Paper Source Settings - Roll Paper Setup - Roll Switching - Auto - Paper Width** from the printer's control panel.

- 2** Select **Optimize Margins** or **Width Match**.

Select **Optimize Margins** to print on the roll paper with smaller margins.

Select **Width Match** to print on the roll paper with the same paper width as the print job.

**Note:**  
Select **Disable** to print regardless of the paper width.

- 3** Display the Print screen on your computer, and make sure roll paper is selected as the **Paper Size**.

In this example, we will select **A1**.

- 4** Make sure that **Auto** is displayed for Roll Switching.

If **Auto** is not displayed, click it and select **Auto**.

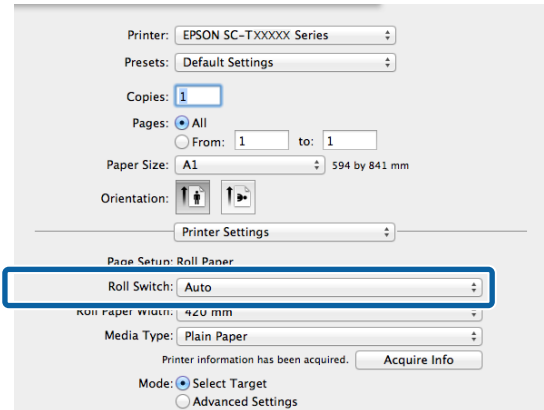

- 5** Make any other necessary settings, such as the **Print Quality**, and then print.

Printing is performed on roll 2 (A0 width) roll paper.

If you select **A3** or **A2** in step 3, printing is performed on roll 1 (A2 width) roll paper.

## Start Printing from Roll with Least Amount Remaining, and Switch Between Roll 1 and Roll 2 when Paper Runs Out

Load paper of the same paper type and the same paper width into Roll 1 and Roll 2, and when the paper runs out, the printer automatically switches the roll paper to continue printing. Printing starts from the roll with the least amount of paper remaining.

### Usage example

- When you want to prioritize the roll paper with the least amount of paper remaining to finish off the roll.
- When you want to continue printing without interruption by automatically switching roll paper to print a large amount of paper in an unattended continuous operation.

## Various Printing Methods

### Settings on Windows

- 1 Select **General Settings - Printer Settings - Paper Source Settings - Roll Paper Setup - Roll Switching - Auto - Paper Length** from the printer's control panel.

- 2 Select **Remaining Amount Priority**.

**Note:**

- Select **Data Length Priority** to prevent the roll paper from being switched during printing. Make the remaining roll paper management settings before printing. [“Paper Setting” on page 138](#)
- Select **Disable** to print regardless of the amount of paper remaining.

- 3 Load paper with the same paper type and the same paper width into roll 1 and roll 2.

- 4 Display the printer driver's Printer Settings screen, and then select **Roll(Auto)** as the **Source**.

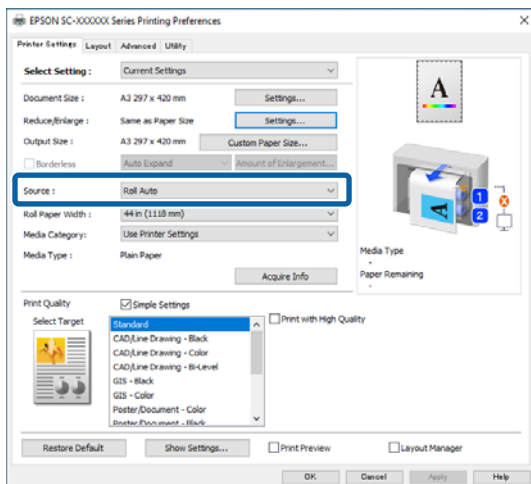

- 5 Make any other necessary settings, such as the **Page Size** and **Print Quality**, and then print.

Printing starts from the roll paper with the least amount of paper remaining. When the paper runs out, the printer automatically switches the roll paper to continue printing.

### Settings in Mac

- 1 Select **General Settings - Printer Settings - Paper Source Settings - Roll Paper Setup - Roll Switching - Auto - Paper Length** from the printer's control panel.

- 2 Select **Remaining Amount Priority**.

**Note:**

- Select **Data Length Priority** to prevent the roll paper from being switched during printing. Make the remaining roll paper management settings before printing. [“Paper Setting” on page 138](#)
- Select **Disable** to print regardless of the amount of paper remaining.

- 3 Load paper with the same paper type and the same paper width into roll 1 and roll 2.

- 4 Display the Print screen on your computer, make sure roll paper is selected as the **Paper Size**, and then select **Printer Settings** from the list.

- 5 Make sure that **Auto** is displayed for Roll Switching.

If **Auto** is not displayed, click it and select **Auto**.

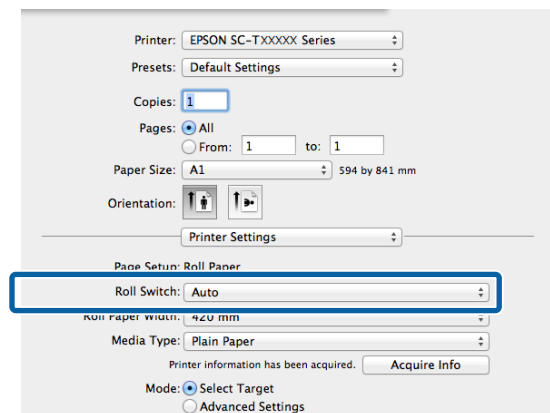

- 6 Make any other necessary settings, such as the **Print Quality**, and then print.

Printing starts from the roll paper with the least amount of paper remaining. When the paper runs out, the printer automatically switches the roll paper to continue printing.

## Various Printing Methods

### Borderless Printing

You can print your data without margins on the paper.

The types of borderless printing you can choose vary as shown below depending on the media type.

Roll Paper: No margins for all edges, no margins for the left and right

Cut Sheets: No margins for the left and right only

(Borderless printing is not available with poster board.)

When printing borderless for all edges, you can also configure the cutting operation. [☞ “About Roll Paper Cutting” on page 97](#)

When performing left and right borderless printing, margins appear on the top and bottom of the paper.

Top/Bottom Margin Values [☞ “Printable area” on page 75](#)

**Note:**

Borderless printing may not be available depending on the paper width being used. See the following for paper widths that support borderless printing.

[☞ “Supported Paper Widths” on page 230](#)

### Types of Borderless Printing Methods

You can perform borderless printing using the following two methods.

Auto Expand

The printer driver enlarges the print data to a size slightly larger than the paper size and prints the enlarged image. The sections which are beyond the paper edges are not printed; therefore, resulting in borderless printing.

Use settings such as Page Setup in the applications to set the size of the image data as follows.

- Match the paper size and page setting for the print data.

- If the application has margin settings, set the margins to 0 mm.
- Make the image data as large as the paper size.

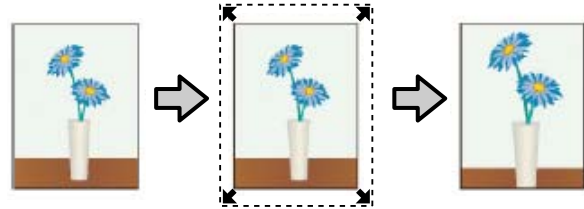

Retain Size

Create the print data larger than the paper size in the applications to produce borderless output. The printer driver does not enlarge the image data. Use settings such as Page Setup in the applications to set the size of the image data as follows.

- Create print data larger than its actual print size by 3 mm on the left and right (6 mm in total).
- If the application has margin settings, set the margins to 0 mm.
- Make the image data as large as the paper size.

Select this setting if you want to avoid image enlargement by the printer driver.

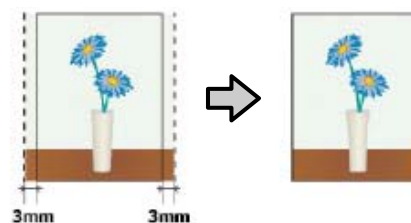

### Supported Paper

Depending on the paper type and size, print quality may decline or borderless printing may not be available.

[☞ “Epson Special Media Table” on page 220](#)

[☞ “Supported Commercially Available Paper” on page 229](#)

## Various Printing Methods

### About Roll Paper Cutting

When performing borderless printing on roll paper, you can specify whether to perform left and right borderless printing or all edges borderless printing, and how to cut the paper in the printer driver's **Advanced - Roll Paper Option**. The cutting operation for each value is shown in the following chart.

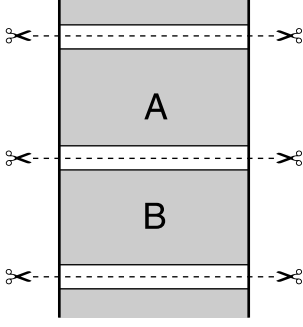
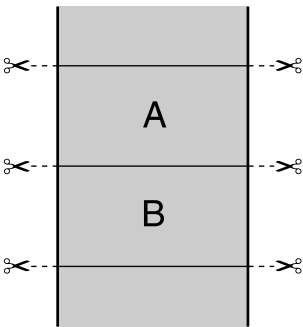
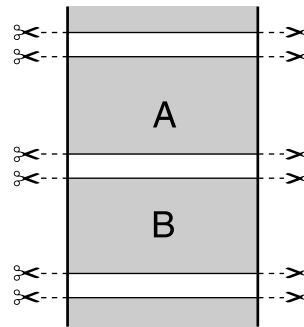
Printer driver settings	Borderless	Single Cut	Double Cut
Cutting Operation			
Explanation	<p>The default printer driver setting is <b>Borderless</b>.</p>	<ul style="list-style-type: none"> <li><input type="checkbox"/> The top area may become slightly uneven depending on the image since the print operation stops while cutting the top edge of the roll paper.</li> <li><input type="checkbox"/> If the cut position is misaligned slightly, small parts of the image may be shown on the top or bottom of the adjacent pages. If this occurs, perform <b>Adjust Cut Position</b>.</li> <li><input type="checkbox"/> When continuously printing multiple sheets, the printer cuts 1 mm inside on the top edge of the first page and the bottom edge of the subsequent pages to avoid showing margins.</li> </ul>	<ul style="list-style-type: none"> <li><input type="checkbox"/> The top area may become slightly uneven depending on the image since the print operation stops while cutting the top edge of the roll paper.</li> <li><input type="checkbox"/> The printed paper is approximately 2 mm shorter than the specified size since the printer cuts the paper inside the image to avoid showing top and bottom margins.</li> <li><input type="checkbox"/> After cutting the bottom edge of the previous page, the printer feeds the paper, and then cuts the top edge of the following page. Although this produces 60 to 127 mm cut-off pieces, the cut is more accurate.</li> <li><input type="checkbox"/> If there is a margin at the top, perform Adjust Cut Position.</li> </ul>

## Various Printing Methods

### Setting Procedures for Printing

#### Settings in Windows

- 1 Display the printer driver's Printer Settings screen, and then set the same paper size as the data's paper size in **Page Size**.

[“Basic Printing Methods\(Windows\)” on page 70](#)

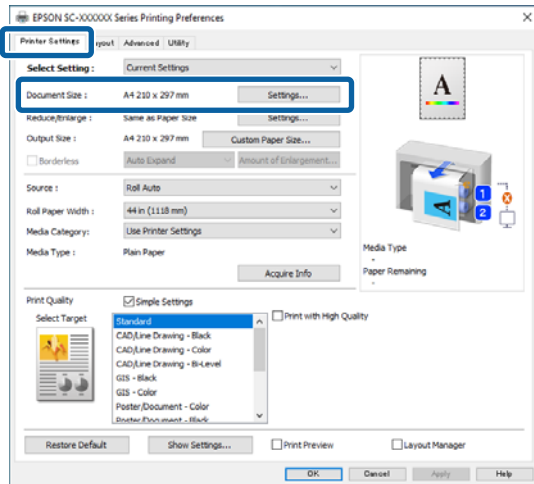

- 2 Select **Settings - Fit to Roll Paper Width**.

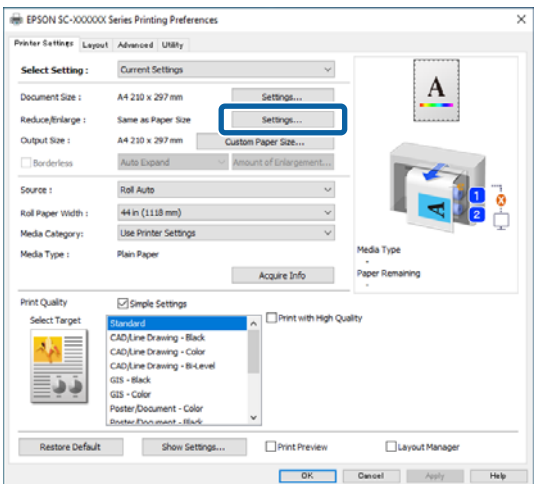

- 3 Select **Borderless**, and then **Amount of Enlargement** to set the amount of enlargement.

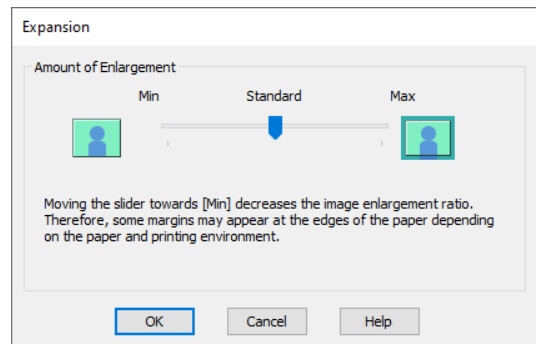
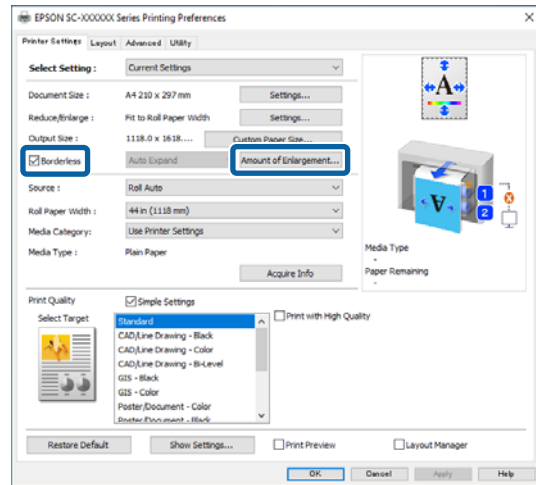

**Note:**  
Moving the slider towards **Standard** decreases the image enlargement ratio. Therefore, some margins may appear at the edges of the paper depending on the paper and printing environment.

- 4 Check other settings, and then start printing.

#### Settings in Mac

- 1 Display the Print screen and select the paper size from the **Paper Size** option, and then select a borderless printing method.

[“Basic Printing Methods\(Mac\)” on page 73](#)

The selections for borderless printing methods are displayed as shown below.

- xxxx (Roll Paper (Borderless, Auto Expand))
- xxxx (Roll Paper (Borderless, Retain Size))
- xxxx (Sheet (Borderless, Auto Expand))
- xxxx (Sheet (Borderless, Retain Size))

## Various Printing Methods

Where XXXX is the actual paper size, such as A4.

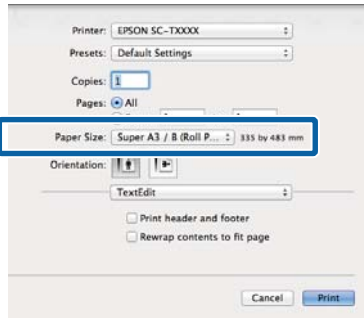

**Note:**

If page setting options are not available in the application's print dialog, display the page settings dialog.

**2**

When you select **Auto Expand** as the paper size, select **Page Layout Settings** from the list, and then click **Amount of Enlargement**.

The following shows the amount of enlargement.

- Max : 3 mm for left and 5 mm for right  
(the image shifts 1 mm to the right)
- Standard : 3 mm left and right
- Min : 1.5 mm left and right



**Note:**

Moving the slider towards **Min** decreases the image enlargement ratio. Therefore, some margins may appear at the edges of the paper depending on the paper and printing environment.

**3**

When printing on roll paper, select **Advanced** from the list, and then set **Auto Cut**.

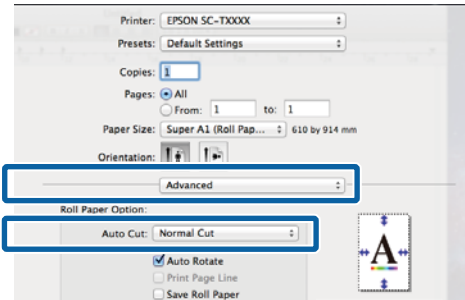

[“About Roll Paper Cutting” on page 97](#)

**4**

Check other settings, and then start printing.

## Correct color and print

The printer driver automatically and internally corrects colors to match the color space. You can select from the following color correction modes. On the SC-T Series, you can select the color correction method by clearing the **Print Quality - Simple Settings** checkbox.

- EPSON Standard (sRGB)  
Optimizes the sRGB space and corrects the color.
- Adobe RGB  
Optimizes the Adobe RGB space and corrects the color.
- Business Graphics (SC-T Series)  
Performs color correction to sharpen your images based on the sRGB space.
- Line Drawing  
Optimizes color correction for line drawing by processing the border between lines and the background as discontinuous.
- ICM  
Performs color management to match the colors in the image data to those in the printed output (Windows only).  
[“Color Management Printing” on page 116](#)
- Off (No Color Adjustment)  
Color correction is not performed by the printer driver. Choose if color management is performed by the application.  
[“Color Management Printing” on page 116](#)

## Various Printing Methods

When you select **EPSON Standard (sRGB)**, **Business Graphics**, or **Line Drawing Settings** in **Color Mode**, the **Settings** button is displayed.

Clicking the **Settings** button allows you to perform operations such as finely adjusting the Gamma, Brightness, Contrast, Saturation, and color balance.

Use this option when the application in use does not have a color correction function.

**Note:**

*The color correction options available vary with the operating system and the type of paper used.*

### Settings in Windows

**1** When using applications featuring a color management function, specify how to adjust colors from these applications.

When using applications without a color management function, start from Step 2.

Depending on the type of the application, make the settings following the table below.

Adobe Photoshop CS3 or later  
 Adobe Photoshop Elements 6 or later  
 Adobe Photoshop Lightroom 1 or later

OS	Color Management Settings
Windows 10, Windows 8.1, Windows 8, Windows 7, Windows Vista	Printer Manages Colors
Windows XP (Service Pack 2 or later and .NET 3.0 or later)	
Windows XP (other than the above)	No Color Management

In other applications, set **No Color Management**.

**Note:**

*For information on supported platforms, see the website for the application in question.*

Setting example for Adobe Photoshop CS5

Open the Print dialog box.

Select **Color Management** and then **Document**. Select **Printer Manages Colors** as the **Color Handling** setting, and then click **Print**.

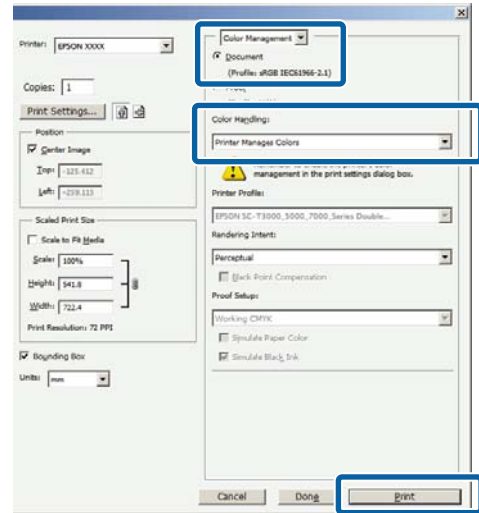

**2** Click the **Color Mode** setting. On the SC-T Series, clear the **Print Quality - Simple Settings** checkbox, and then click the **Color Mode** setting.

[“Basic Printing Methods\(Windows\)” on page 70](#)

To make fine adjustments, click **Settings**.

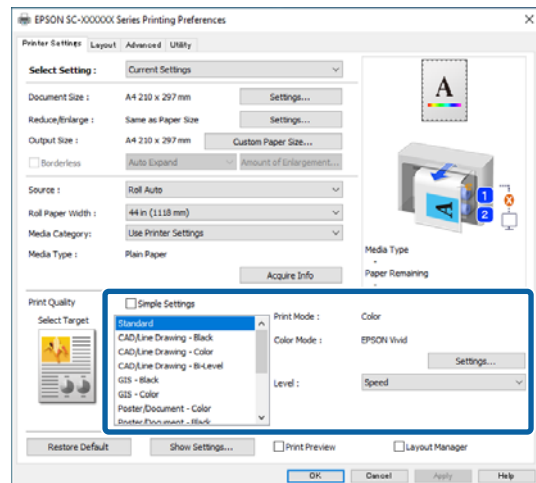

## Various Printing Methods

- 3** When you click **Settings**, you can adjust items such as the **Gamma**, **Brightness**, **Contrast**, **Saturation**, and color balance.

See the printer driver help for more details on each item.

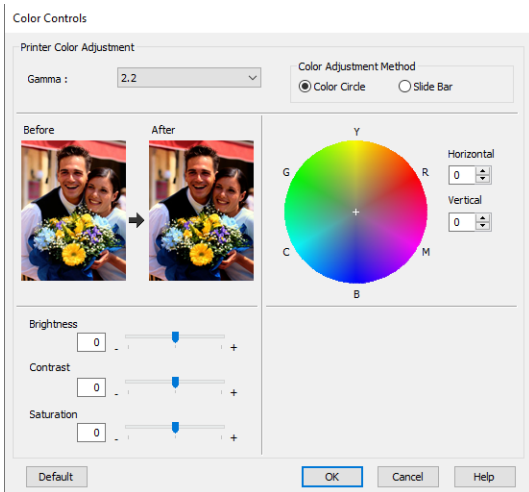

**Note:**

You can adjust the correction value by checking the sample image on the left side of the screen. Furthermore, you can select **Color Circle** or **Slide Bar** from **Color Adjustment Method** and finely adjust the color balance.

- 4** Check other settings, and then start printing.

### Settings in Mac

- 1** When using applications featuring a color management function, specify how to adjust colors from these applications.

When using applications without a color management function, start from Step 2.

When using the following applications, set the color management setting to **Printer Manages Colors**.

Adobe Photoshop CS3 or later  
 Adobe Photoshop Elements 6 or later  
 Adobe Photoshop Lightroom 1 or later

In other applications, set **No Color Management**.

**Note:**

For information on supported platforms, see the website for the application in question.

Setting example for Adobe Photoshop CS5

Open the Print dialog box.

Select **Color Management** and then **Document**. Select **Printer Manages Colors** as the **Color Handling** setting, and then click **Print**.

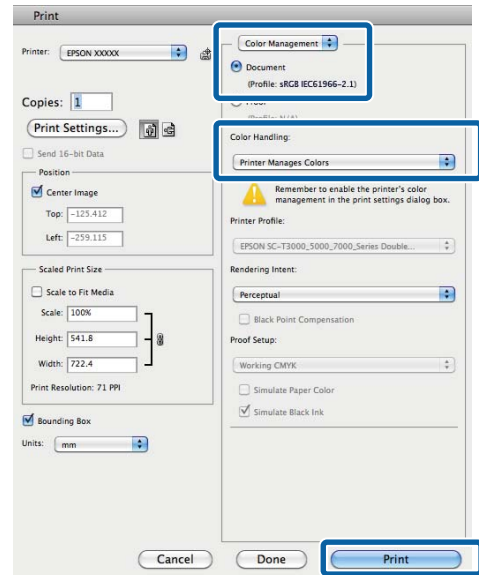

- 2** Display the Print screen.

[“Basic Printing Methods\(Mac\)” on page 73](#)

- 3** Select **Color Matching** from the list, and then click **EPSON Color Controls**.

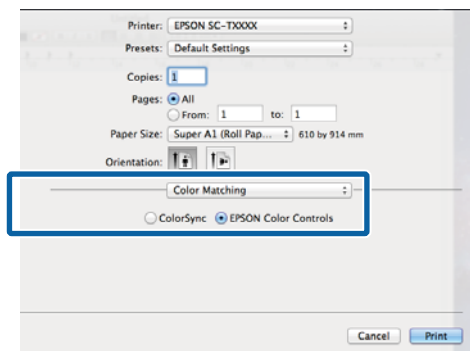

**Note:**

**EPSON Color Controls** will not be available in the following applications if Step 1 is omitted.

- Adobe Photoshop CS3 or later
- Adobe Photoshop Lightroom 1 or later
- Adobe Photoshop Elements 6 or later

## Various Printing Methods

**4** Select **Printer Settings** from the list, and then select **Advanced Settings** in **Mode Settings**.

**5** Select a color mode method in **Color Mode**.  
To make fine adjustments, click **Settings**.

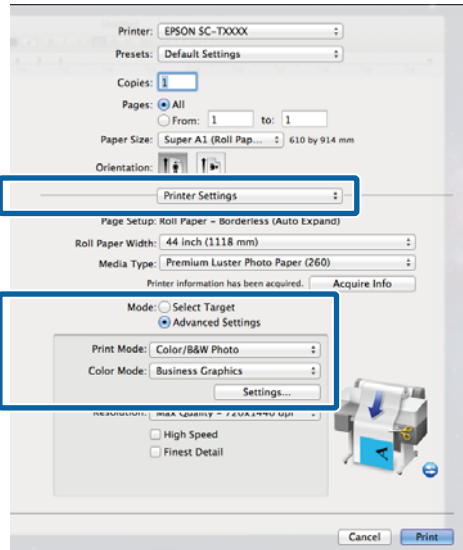

**Note:**

If you are using any of the following applications on Mac OS X v10.5, clear the **Use Generic RGB** check box.

- Adobe Photoshop CS3 or later
- Adobe Photoshop Lightroom 1 or later
- Adobe Photoshop Elements 6 or later

Select this if you are using software other than the above.

**6** Make the necessary settings.

See the printer driver help for more details on each item.



**7** Check other settings, and then start printing.

## N-up/Poster

You can print multiple pages of data on a single sheet, or print a single page across multiple sheets.

There are three ways available to print N-up/Posters.

- **Folded Double-Side (Windows only)**

Two consecutive pages can be printed on a single sheet. The second page is flipped 180° and printed adjacent to the first page, allowing the paper to be folded to make a 2-sided document.

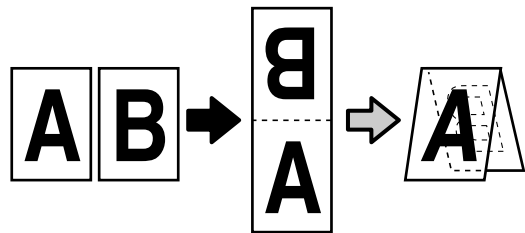

- **N-up**

Two or four consecutive pages can be printed on a single sheet.

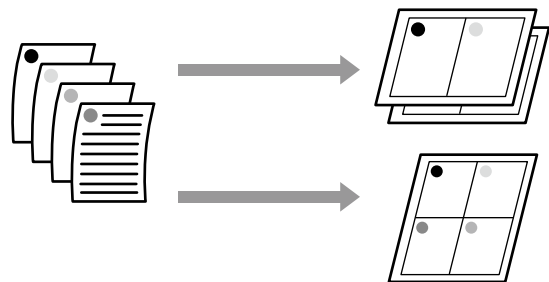

## Various Printing Methods

### • Poster (Windows Only)

A single page can be printed across multiple sheets. The sheets can then be joined together to form large posters (up to 16 times the original size). When **Borderless Poster Print** is enabled, you can splice the output paper as it is without cutting the margins, but the parts of the image that expand beyond the edges in borderless printing are lost, which means the image may misalign at the joins.

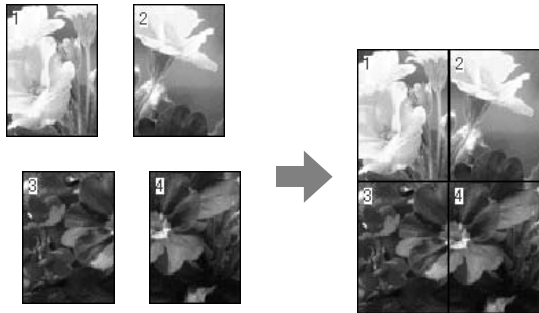

## Folded Double-Side (Windows only)

**1** Display the Layout tab of the printer driver, and then select **Page Layout**. Select **Folded Double-Side** and click the **Settings** button.

[“Basic Printing Methods\(Windows\)” on page 70](#)

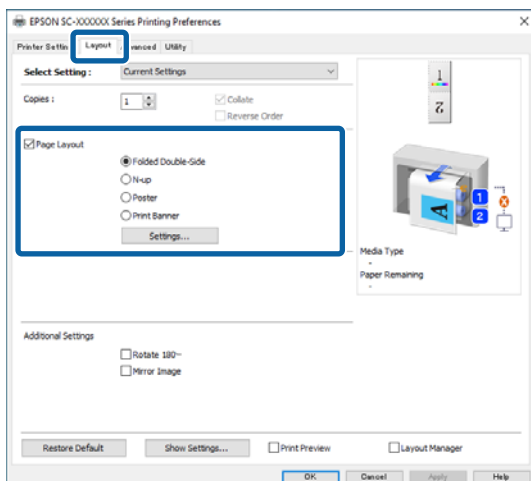

**2** Set **Binding Edge** and **Binding Margin** in the **Folded Double-Side Setting** dialog box.

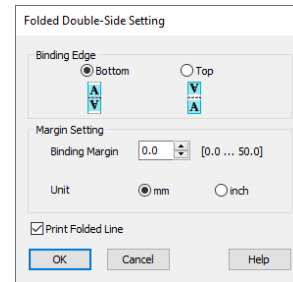

**3** Check other settings, and then start printing.

## Multi-Page Printing (N-up)

### Note:

- In Windows, you cannot use the N-up printing function when performing borderless printing.
- In Windows, you can use the Reduce/Enlarge function (Fit to Page) to print the data on different sizes of paper.

[“Printing at Non-Standard Sizes” on page 88](#)

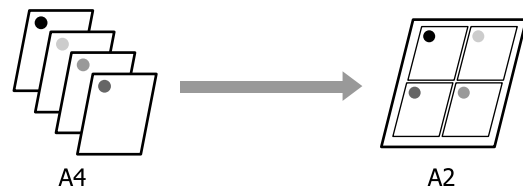

## Various Printing Methods

### Settings in Windows

- 1 Display the Layout tab of the printer driver, and then select **Page Layout**. Select **N-up** and click the **Settings** button.

“Basic Printing Methods(Windows)” on page 70

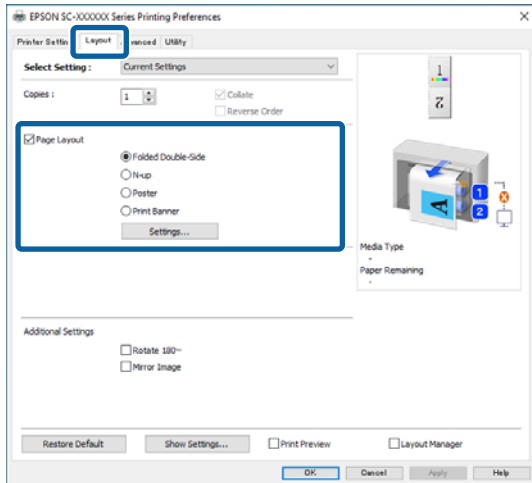

- 2 Set **Number of pages per sheet** and **Page Order** in the Print Layout dialog box.

If the **Print page frames** check box is selected, page frames are printed on each page.

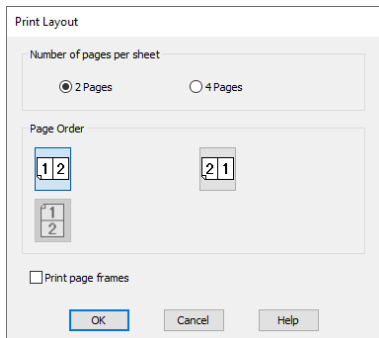

- 3 Check other settings, and then start printing.

### Settings in Mac

- 1 Display the Print dialog box, select **Layout** from the list, and specify the number of pages per sheet and so on.

“Basic Printing Methods(Mac)” on page 73

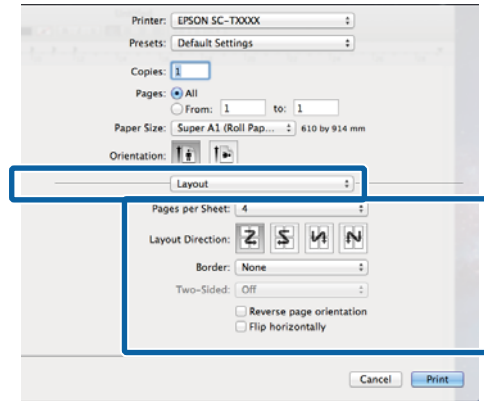

**Note:**

You can print frames around arranged pages using the **Border** function.

- 2 Check other settings, and then start printing.

## Poster (Windows Only)

- 1 Display the Layout tab of the printer driver, and then select **Page Layout**. Select **Poster** and click the **Settings** button.

“Basic Printing Methods(Windows)” on page 70

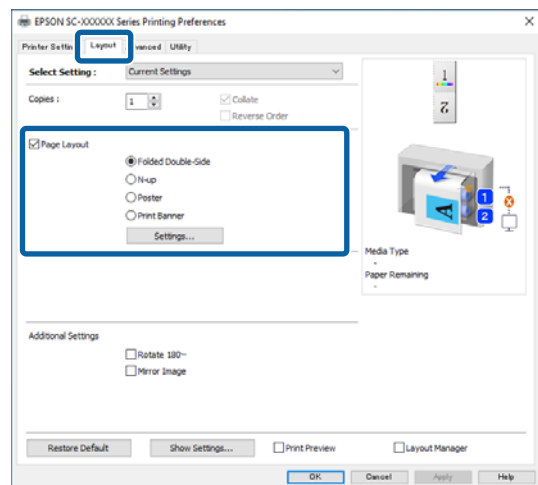

## Various Printing Methods

**2** Set Number of panels in the Poster dialog box.

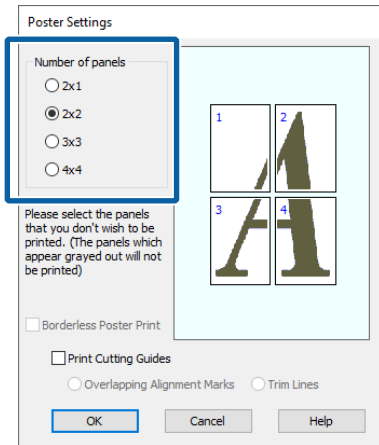

**3** Select whether to print the poster with or without borders.

**When borderless is selected:**

Select **Borderless Poster Print**.

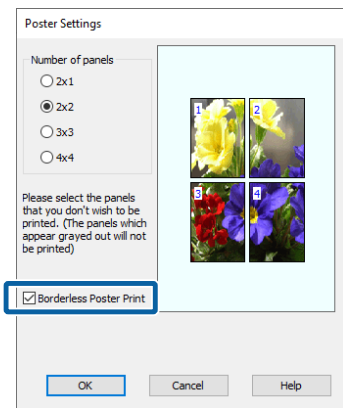

**Note:**

- If **Borderless Poster Print** is grayed out, the selected paper or the size does not support borderless printing.  
[🔗 "Supported Paper" on page 96](#)
- If **Auto Cut** is set to **Single Cut** or **Double Cut**, the image is cut 1 to 2 mm inside the edge of the image, which means the image may misalign at the joins.

**When with margins is selected:**

Clear **Borderless Poster Print**.

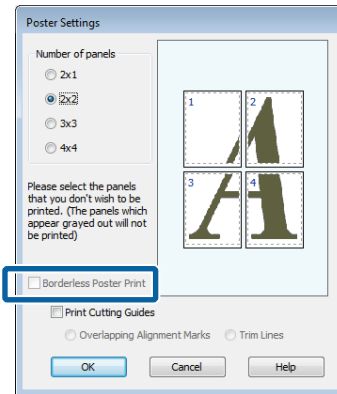

**Note:**

*Regarding the size after joining together:*

*When **Borderless Poster Print** is cleared, the **Print Cutting Guides** items are displayed.*

*The finished size is the same whether or not **Print page frames** is selected. However, if **Overlapping Alignment Marks** is selected, the finished size is smaller with an overlap.*

**4** Check other settings, and then start printing.

### Joining poster sheets with borders in multi-page printing

If **Overlapping Alignment Marks** is selected, join guides (indicated by the lines drawn through and around the X marks in the illustration below) will be printed on each sheet.

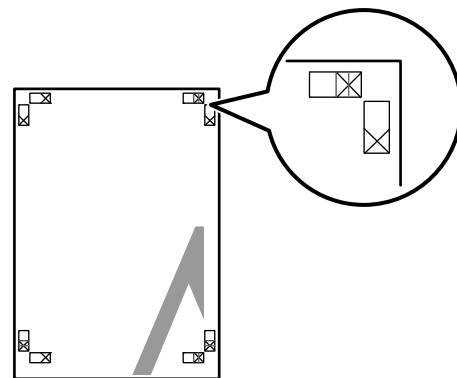

## Various Printing Methods

**Note:**

If the output is in color, the join guides will be in blue and the cut guides in red; otherwise, all the guides will be printed in black.

The following section describes how to join four printed pages together.

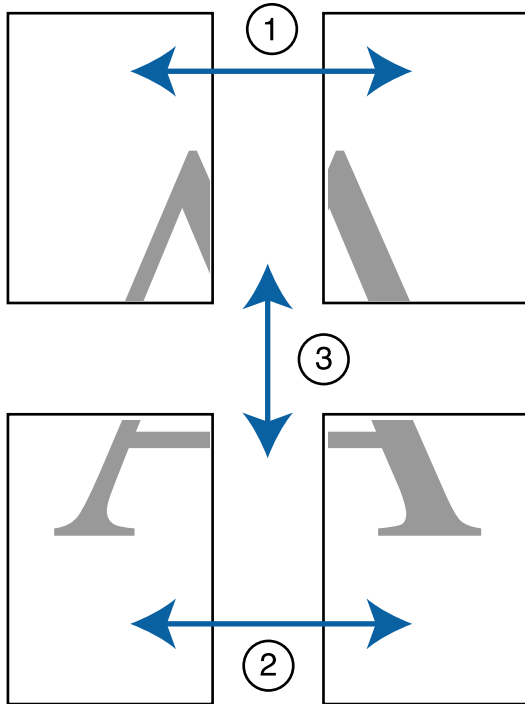

- 1 Ready the two top sheets and trim the excess from the left sheet by cutting along the line joining the two join guides (the centers of the X marks).

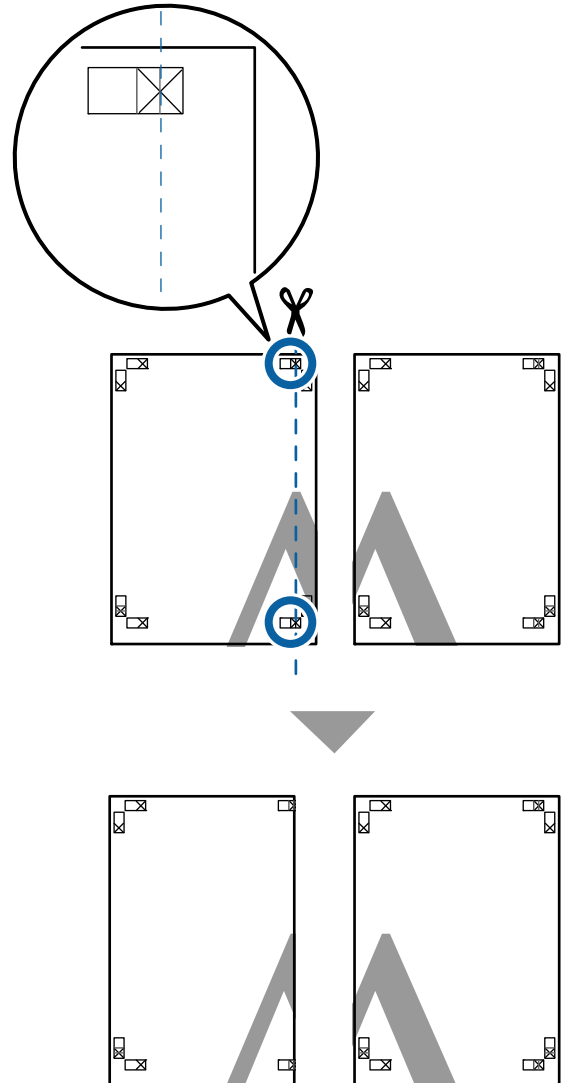

- 2 Lay the upper left sheet on top of upper right sheet. Lineup the X marks as shown in the illustration below, and temporarily fasten them using an adhesive tape on the back.

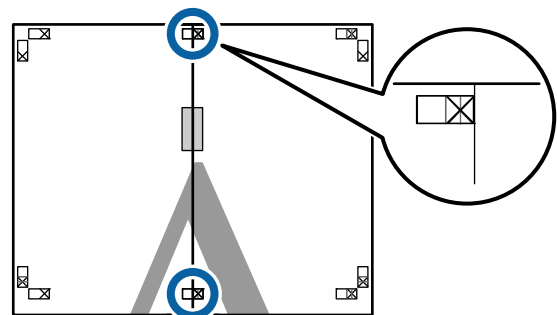

### Various Printing Methods

- 3** With the two sheets overlapping, trim the excess by cutting along the line joining the two cut guides (the lines to the left of the X marks).

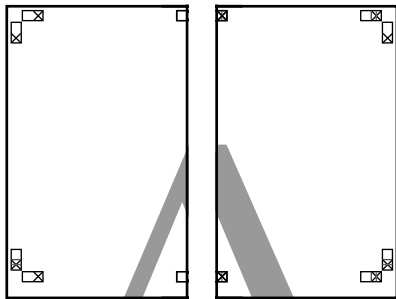
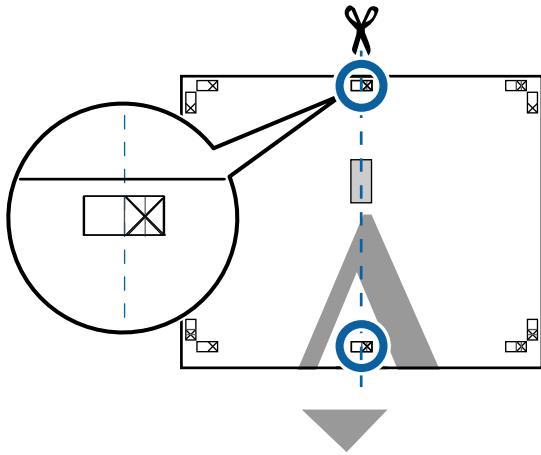

- 4** Rejoin the two sheets.  
Use an adhesive tape to stick the backs of the sheets together.

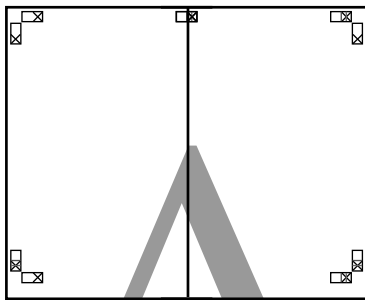

- 5** Follow steps 1 to 4 to join the lower two sheets.

- 6** Trim the bottom from the upper sheets by cutting along the line joining the two guides (the lines above the X marks).

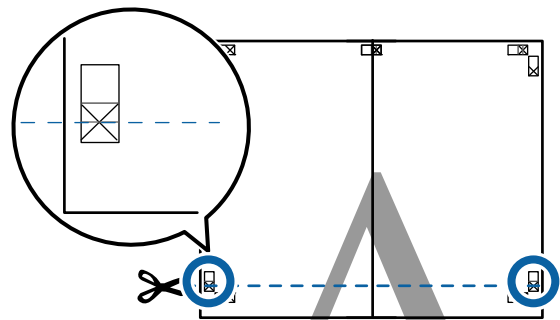

- 7** Lay the upper sheet on top of the lower sheet. Lineup the X marks as shown in the illustration below, and temporarily fasten them using an adhesive tape on the back.

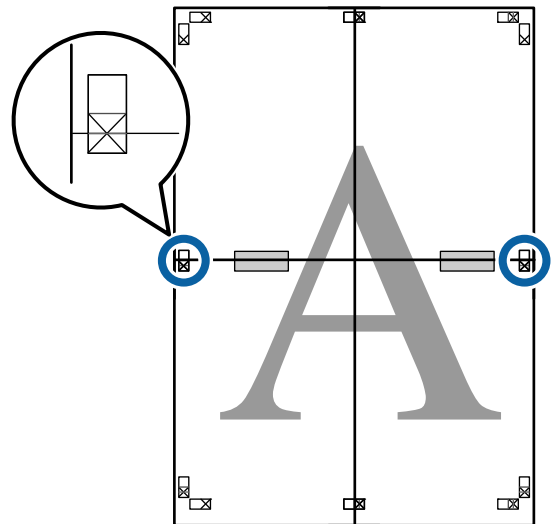

### Various Printing Methods

- 8** With the two sheets overlapping, trim the excess by cutting along the line joining the two cut guides (the lines above the X marks).

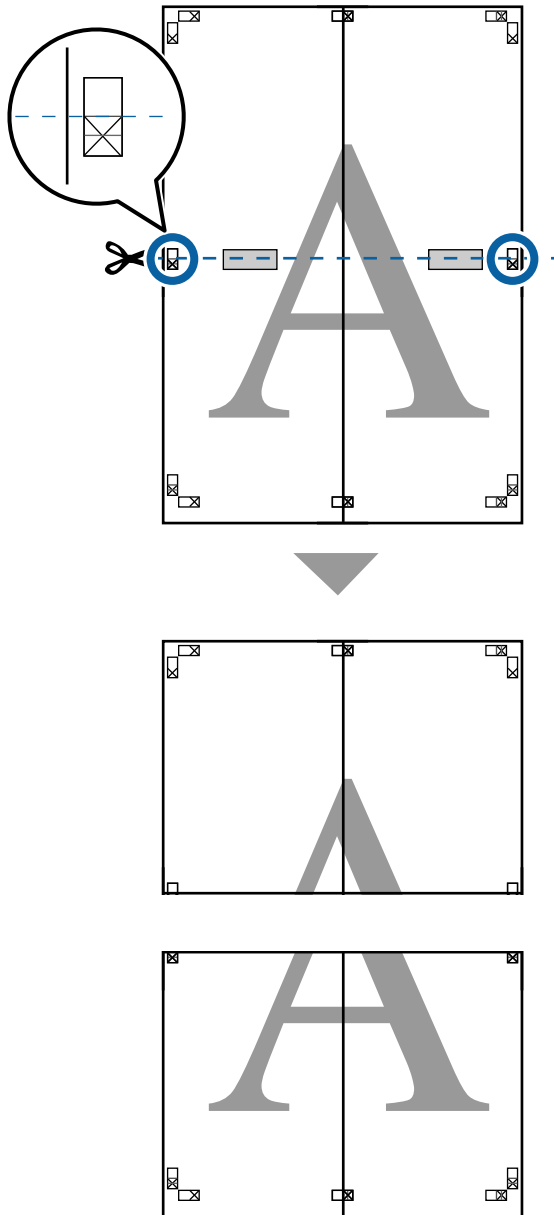

- 9** Join the upper and lower sheets together. Use an adhesive tape to stick the backs of the sheets together.

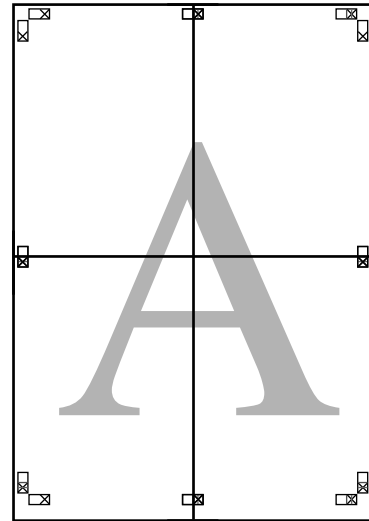

## Various Printing Methods

- 10** After joining all the sheets, trim off the borders by cutting along the cut guides (outside the X marks).

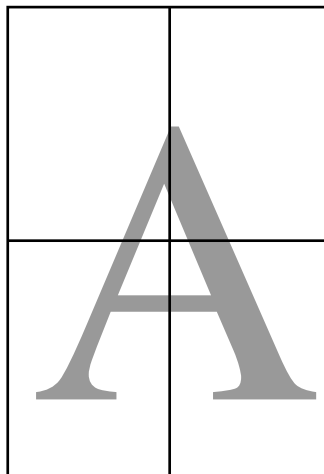
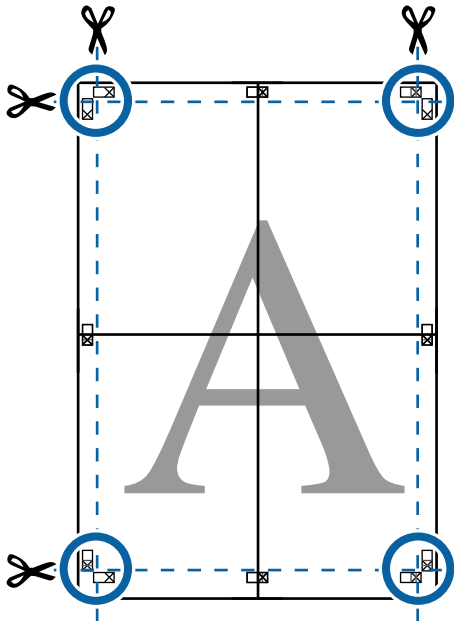

## Poster Layout (Windows only)

The poster layout function allows you to arrange multiple items of print data created with different applications on a sheet of paper and print them all at once.

You can layout multiple items to create posters and exhibition material. It also provides a more efficient use of paper when printing.

### Sample Multi-Document Layout

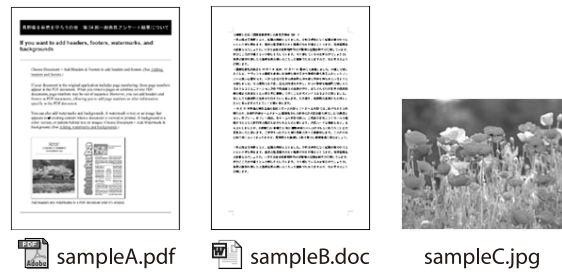

### Sample Free Vertical/Horizontal Layout

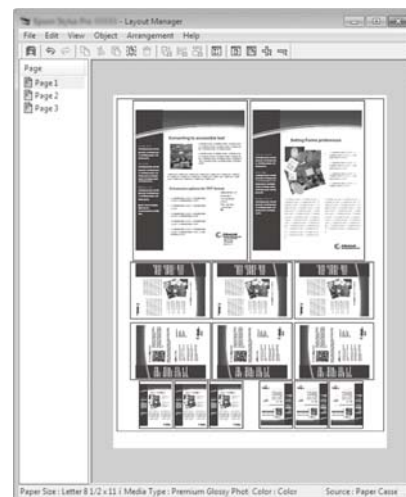

## Various Printing Methods

### Setting Procedures for Printing

- 1 Open the file you want to print in your application.
- 2 Select **Layout Manager** on the printer driver's Printer Settings screen, and then in **Paper Size** set the page size created by the application.

 [“Basic Printing Methods\(Windows\)” on page 70](#)

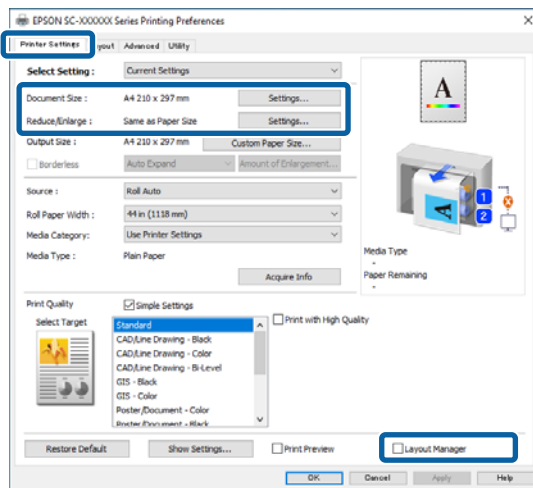

**Note:**

The **Page Size** is the size that will be placed on the **Layout Manager** screen. Set the actual paper size to be printed on the screen in step 6.

- 3 After clicking **OK**, the **Layout Manager** screen opens when printing using your application.  
The data is not printed, but placed on the paper in the **Layout Manager** screen where one page is one object.
- 4 Leave the **Layout Manager** screen open and repeat steps 1 to 3 to place the next item.  
The object is added to the **Layout Manager** screen.
- 5 Arrange the layout for the objects on the **Layout Manager** screen.

Objects can be moved or resized by dragging as well as rearranged or rotated using the tool buttons or the options in the **Object** menu.

You can change the size and position of each object in the **Preferences** or **Arrangement** menus from the **File** menu.

For details on each function, see the help on the **Layout Manager** screen.

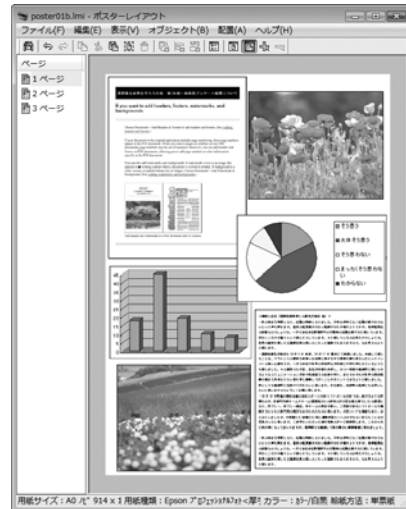

- 6 Click the **File** menu - **Properties** to set the print settings on the printer driver screen.

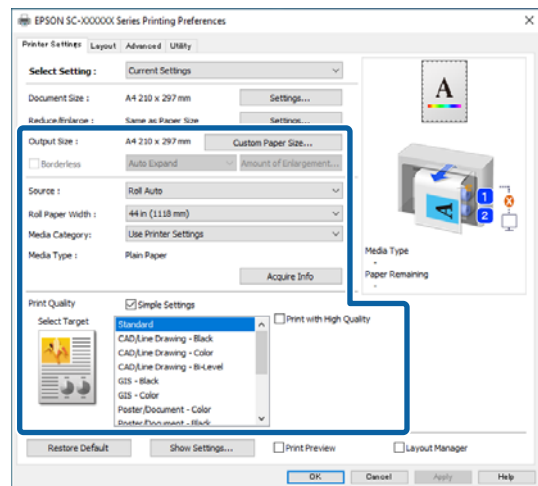

Set each item such as **Paper Setting**, **Source**, or **Paper Size** (or **Roll Paper Width** for roll paper).

- 7 Click the **File** menu on the **Layout Manager** screen, and then click **Print**.  
Printing starts.

### Saving and Recalling Settings



You can save the layout and setting information on the **Layout Manager** screen as a file. If you need to close your application in the middle of a job, you can save it to a file and then open it later to continue your work.

## Various Printing Methods

### Saving

- 1 On the Layout Manager screen, click the **File** menu - **Save As...**
- 2 Enter the file name, select the location, and then click **Save**.
- 3 Close the Layout Manager screen.

### Opening saved files

- 1 Right-click the Utility shortcut icon  on the Windows taskbar, and then click **Layout Manager** in the menu displayed.  
The Layout Manager screen is displayed.  
If the Utility shortcut icon is not displayed on the Windows taskbar:  [“Summary of the Utility Tab” on page 125](#)
- 2 On the Layout Manager screen, click the **File** menu - **Open**.
- 3 Select the location and open the required file.

## Using Epson Smart Panel (Except for Models that do not Support Wireless LAN)

You can print photos and documents from smart devices such as smartphones and tablets.

**Note:**

*The operations differ depending on the device.*

- 1 Load the paper into the printer.
- 2 Connect the printer to a Wi-Fi network.

- 3 If it is not already installed, install Epson Smart Panel.  
 [“Introducing the Software” on page 26](#)
- 4 Connect the smart device to the same Wi-Fi network as the printer.
- 5 Start the Epson Smart Panel and follow the instructions in the application to print.

## Using AirPrint

AirPrint enables instant wireless printing from iPhone, iPad, iPod touch, and Mac without the need to install drivers or download software.

Except for models that do not support wireless LAN.



- 1 Load paper in your product.
- 2 Set up your product for wireless printing. See the link below.  
<http://epson.sn>
- 3 Connect your Apple device to the same wireless network that your product is using.
- 4 Print from your device to your product.

**Note:**

*For details, see the AirPrint page on the Apple website.*

## Various Printing Methods

# Printing Over the Web (Upload Printing)

## Function Summary

Uploaded and Print is a function that allows you to start Web Config and print from a computer that does not have a printer driver installed.

You can print by simply selecting the file you want to print, and then uploading it to the printer. If the browser you are using supports drag and drop, you can upload multiple files in a batch and print them in order.

The following are files that can print from an upload.

- JPEG
- HP-GL/2
- TIFF
- PDF (Models without the Adobe® PostScript® 3™ expansion unit can only print data created using the scan function provided by Epson inkjet printers.)

## Upload and Print Procedure

- 1 Load the paper into the printer.
- 2 Start Web Config.  
 [“Using Web Config” on page 35](#)
- 3 Display the **Print** tab, and then click **Upload and Print**.

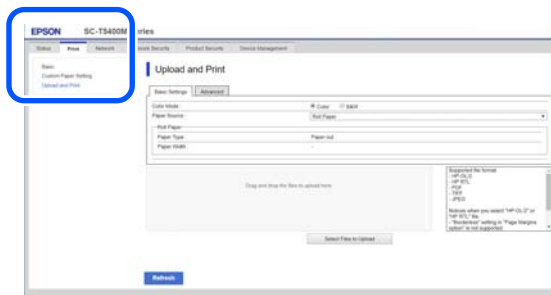

**Note:**  
If the **Print** tab does not appear, contact your system administrator.

- 4 Do the settings for printing.  
Select Color Mode and Paper Source in **Basic Settings**.

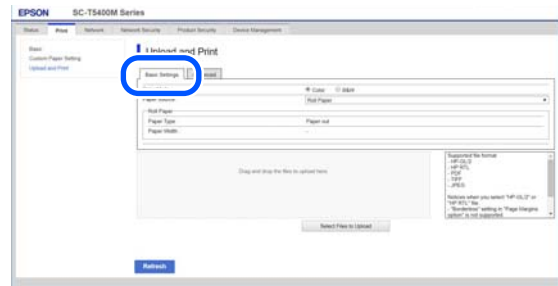

Do the settings, such as Quality, from **Advanced**.

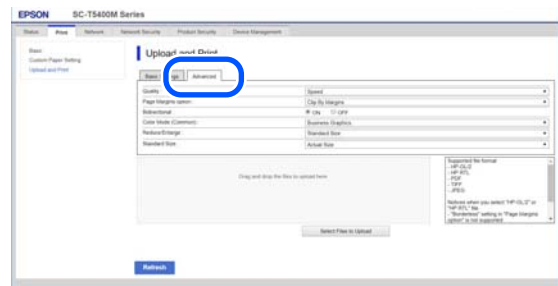

**Note:**  
You need the optional SSD Unit to print multiple copies. Install the SSD Unit and create a Storage space.

 [“Creating a Storage Space” on page 80](#)

- 5 Start printing by dragging and dropping the data.

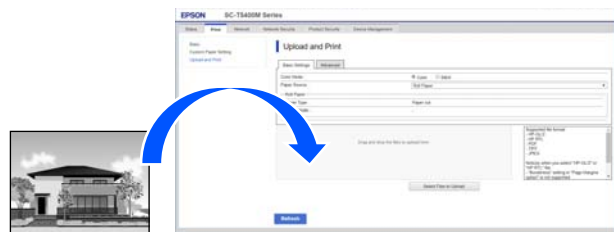

## Various Printing Methods

# Printing Files in a Shared Folder (Folder Printing)

## Function Summary

You can select and print a file from a shared folder on the network that has been setup in advance.

Make the settings for the shared folder on the printer's screen or in Web Config.

 [“Preparing a Shared Folder” on page 113](#)

The following files can be printed from a network folder/FTP.

- JPEG
- HP-GL/2
- TIFF
- PDF (Models without the Adobe® PostScript® 3™ expansion unit can only print data created using the scan function provided by Epson inkjet printers.)

## Preparing a Shared Folder

### Setup from the printer

- 1** Press **Menu** on the Home screen.
- 2** Press **General Settings - Network Settings - Advanced - Shared Folder**.

The shared folder settings screen appears.

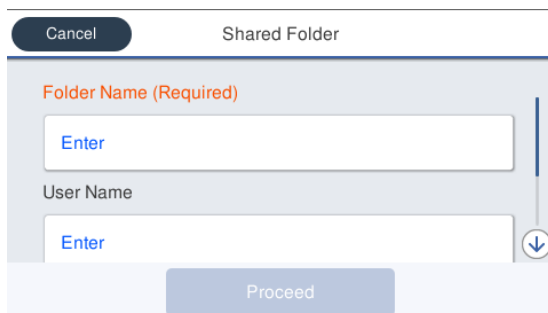

- 3** Enter each item.
  - Folder Name: Within 255 characters, enter the network path for the shared folder.
  - User Name: Enter the user name that you use to log into the computer.
  - Password: Enter the password that you use to log into the computer.
- 4** Press **Proceed** to complete the settings for the shared folder.

### Setup from Web Config

- 1** Start Web Config.
  -  [“Using Web Config” on page 35](#)
- 2** Display the **Print** tab, and then click **Basic**.



**Note:**  
If the **Print** tab does not appear, contact your system administrator.

- 3** Enter each item for **Print from Folder**.
  - Print from Folder: Select enable.
  - Folder Name: Enter the network path for the shared folder.
  - User Name: Enter the user name that you use to log into the computer.
  - Password: Enter the password that you use to log into the computer.

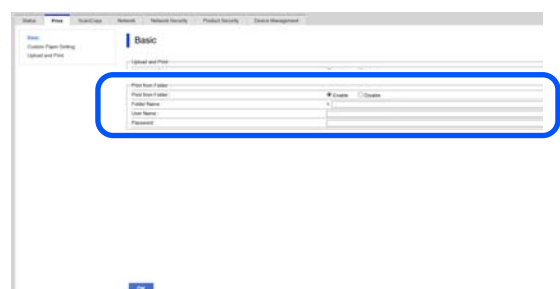

## Various Printing Methods

- Click **OK** to complete the settings for the shared folder.

### Print from Folder Procedure

The procedure to print from a folder from the printer's screen is as follows.

- On the Home screen, press **Network Folder**.  
After a short while, a list of the files in the shared folder appears.

- Select 1 file to print.

- Select **B&W** or **Color**.  
**Using advanced settings such as enlarging or reducing size**

Go to step 4.

#### Printing at actual size without advanced settings

Go to step 5.

**Note:**

You need the optional SSD Unit to print multiple copies. Install the SSD Unit and create a Storage space.

 ["Creating a Storage Space" on page 80](#)

- Press the **Advanced** tab.  
You can set the reduce/enlarge ratios in Reduce/Enlarge. If you set **Auto Fit Page** to **On**, printing is performed by automatically enlarging to fit the width of the roll paper or the size of the cut sheet paper loaded in the printer.

Set other items.

**Note:**

When **Page Margins option - Borderless** is selected, either **Clip By Margins** or **Oversize** in the **Menu - General Settings - Printer Settings - Universal Print Settings - Page Margins option** is applied for HP-GL/2 files.

You can select **Reduce/Enlarge** in HP-GL/2 files, but it is not applied.

- Press the **Print** button.

### Printing Files Directly from a USB Flash Drive

By connecting a USB flash drive to the printer, you can print JPEG or TIFF files stored in the memory directly from the printer.

PDF files are also supported. (Models without the Adobe® PostScript® 3™ expansion unit can only print data created using the scan function provided by Epson inkjet printers.)

USB flash memories formatted in FAT and exFAT file systems can be used. However, you cannot use USB flash memories with security functions such as password protected ones.

- Connect the USB flash memory, in which the data to be printed is saved, to the printer.

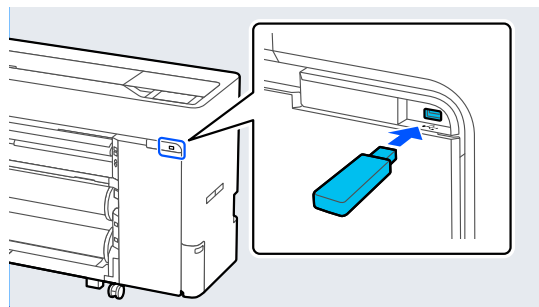

- Press **Memory Device** on the Home screen.

- Press **JPEG**, **TIFF**, **PDF**, or **HP-GL/2**.

- Select 1 file to print.

#### When selecting JPEG

Press to select the file image to print, and then press **Proceed to Print**.

This will add a check mark to the selected image. Press **Single View** to enlarge the selected image to confirm.

#### When selecting TIFF or PDF

From the list, press a file name to select it.

## Various Printing Methods

**Note:**

- ❑ Files in formats other than JPEG, TIFF, or PDF are not displayed on the printer's screen.
- ❑ Any characters in the folder or file names that cannot be displayed by the printer is displayed as "?".

**5**

Select **B&W** or **Color**.

Using advanced settings such as enlarging or reducing size

Go to step 6.

Printing at actual size without advanced settings

Go to step 7.

**Note:**

- ❑ Except for the SC-P6500DE Series/ SC-P6500E Series/SC-T3700DE Series/ SC-T3700E Series:  
You need the optional SSD Unit to print multiple copies. Install the SSD Unit and create a Storage space.  
[🔗 "Creating a Storage Space" on page 80](#)
- ❑ SC-P6500DE Series/SC-P6500E Series/ SC-T3700DE Series/SC-T3700E Series:  
The optional SSD Unit is required to print multiple copies of HPGL/HPGL2 files. Install the SSD Unit and create a Storage space.  
[🔗 "Creating a Storage Space" on page 80](#)

**6**

Press the **Advanced** tab.

You can set the reduce/enlarge ratios in Reduce/Enlarge. If you set **Auto Fit Page to On**, printing is performed by automatically enlarging to fit the width of the roll paper or the size of the cut sheet paper loaded in the printer.

Set other items.

**Note:**

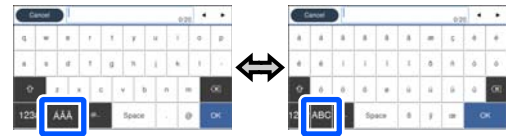

Each press of the following bottom left icon switches the input method as follows.

AB: Enter the alphabet

1#: Enter numbers and symbols

**7**

Press the numeric value for the number of prints and then enter the number of prints in the keypad screen.

**Note:**

The **Preview** button allows you to check the print image (JPEG, TIFF, or PDF only).

**8**

Press the **Print** button.

## Color Management Printing

# Color Management Printing

## About Color Management

Even when using the same image data, the original image and the displayed image may look different, and the printed results may look different to the image you see on the display. This occurs due to the difference in characteristics when input devices such as scanners and digital cameras capture colors as electronic data, and when output devices such as display screens and printers reproduce colors from the color data. The color management system is a means to adjust differences in color conversion characteristics among input and output devices. A color management system is included with operating systems such as Windows and Mac OS, in addition to image processing applications. Windows includes the ICM color management system, and Mac OS X includes ColorSync color management system.

In a color management system, a color definition file called a "Profile" is used to perform color matching between devices. (This file is also called an ICC profile.) The profile of an input device is called an input profile (or source profile), and the profile of an output device, such as a printer, is called a printer profile (or output profile). A profile is prepared for each media type in this printer's driver.

The color conversion areas by the input device and the color reproduction area by the output device differ. As a result, there are color areas that do not match even when performing color matching using a profile. In addition to specifying profiles, the color management system also specifies conversion conditions for areas where color matching failed as "intent". The name and type of intent vary depending on the color management system you are using.

You cannot match the colors on the printed results and display by color management between the input device and the printer. To match both colors, you need to perform color management between the input device and the display as well.

## Color Management Print Settings

You can perform color management printing using this printer's printer driver in the following two ways.

Choose the best method according to the application you are using, the operating system environment, the aim of the print out, and so on.



### Setting color management with applications

This method is for printing from applications that support color management. All color management processes are carried out by the application's color management system. This method is useful when you want to obtain the same color management print results using a common application among different operating system environments.

 ["Setting color management with applications" on page 117](#)

### Setting color management with the printer driver

The printer driver uses the operating system's color management system and carries out all color management processes. You can configure the color management settings in the printer driver using the following two methods.

- Host ICM (Windows) / ColorSync (Mac OS X)  
Set when printing from applications that support color management. This is effective in producing similar print results from different applications under the same operating systems.  
 ["Color Management Printing by Host ICM \(Windows\)" on page 118](#)  
 ["Color Management Printing by ColorSync \(Mac\)" on page 119](#)
- Driver ICM (Windows only)  
This allows you to perform color management printing from applications that do not support color management.  
 ["Color Management Printing by Driver ICM\(Windows only\)" on page 120](#)

## Color Management Printing

### Setting profiles

Settings for the input profile, printer profile, and intent (matching method) vary between three types of color management printing since their color management engines are used differently. This is because color management usage differs between the engines. Make settings in the printer driver or application as described in the following table.

	Input profile settings	Printer profile settings	Intent settings
Driver ICM (Windows)	Printer Driver	Printer Driver	Printer Driver
Host ICM (Windows)	Application	Printer Driver	Printer Driver
ColorSync (Mac OS X)	Application	Printer Driver	Application
Application	Application	Application	Application

Printer profiles for each paper type that is needed when performing color management printing are installed with the printer's printer driver. You can select the profile from the printer driver's settings screen.

You can select the profile from the printer driver's settings screen.

[“Color Management Printing by Driver ICM\(Windows only\)” on page 120](#)

[“Color Management Printing by Host ICM \(Windows\)” on page 118](#)

[“Color Management Printing by ColorSync \(Mac\)” on page 119](#)

[“Setting color management with applications” on page 117](#)

### Setting color management with applications

Print using applications with a color management function. Make the color management settings in the application and disable the printer driver's color adjustment function.

- 1 Make color management settings in the applications.

Setting example for Adobe Photoshop CS5

Open the Print dialog box.

Select **Color Management** and then **Document**. Select **Photoshop Manages Colors** in **Color Handling**, select **Printer Profile** and **Rendering Intent**, and then click **Print**.

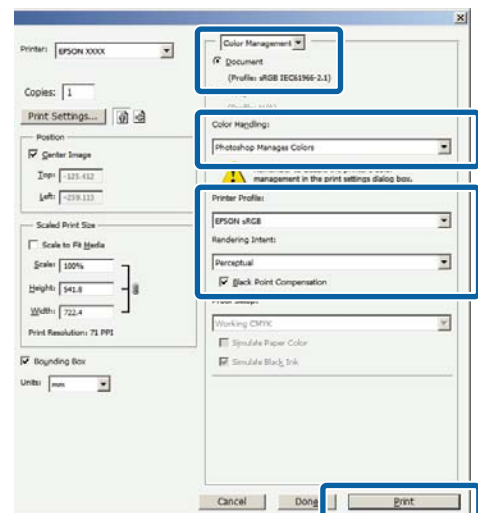

- 2 Display the printer driver settings screen (Windows) or print screen (Mac).

Make printer driver settings.

**For Windows**

[“Basic Printing Methods\(Windows\)” on page 70](#)

**For Mac**

[“Basic Printing Methods\(Mac\)” on page 73](#)

## Color Management Printing

3

Set color management to off.

**For Windows**

Clear the **Simple Settings** checkbox in **Print Quality** on the Printer Settings screen, and then select **No Color Management**.

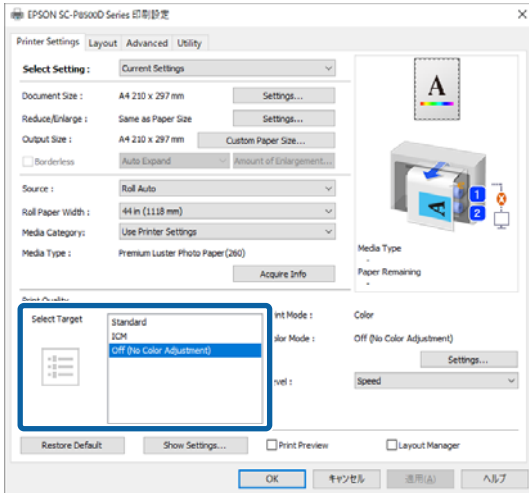

**For Mac**

Select **Printer Settings** from the list, and then select **Advanced Settings** in **Mode Settings**. Also, set the **Color Mode** to **Off (No Color Adjustment)**.

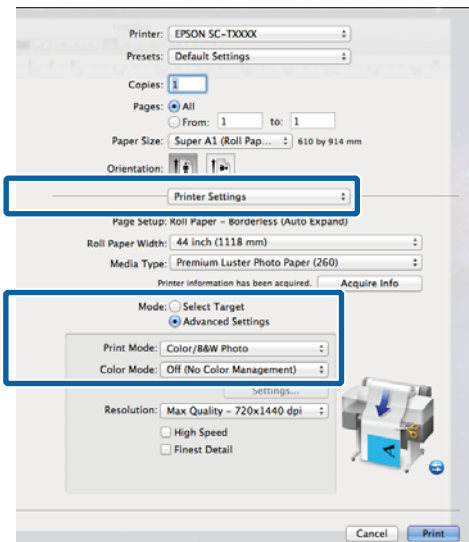

4

Check other settings, and then start printing.

## Setting Color Management with the Printer Driver

### Color Management Printing by Host ICM (Windows)

Use image data in which an input profile has been embedded. The application must also support ICM.

1

Make the settings for color adjustment using the application.

Depending on the type of the application, make the settings following the table below.

Adobe Photoshop CS3 or later  
 Adobe Photoshop Elements 6 or later  
 Adobe Photoshop Lightroom 1 or later

OS	Color Management Settings
Windows 11, Windows 10, Windows 8.1, Windows 8, Windows 7, Windows Vista	Printer Manages Colors
Windows XP (Service Pack 2 or later and .NET 3.0 or later)	Printer Manages Colors
Windows XP (other than the above)	No Color Management

In other applications, set **No Color Management**.

**Note:**  
 For information on supported platforms, see the website for the application in question.

Setting example for Adobe Photoshop CS5

Open the Print dialog box.

## Color Management Printing

Select **Color Management** and then **Document**. Select **Printer Manages Colors** as the **Color Handling** setting, and then click **Print**.

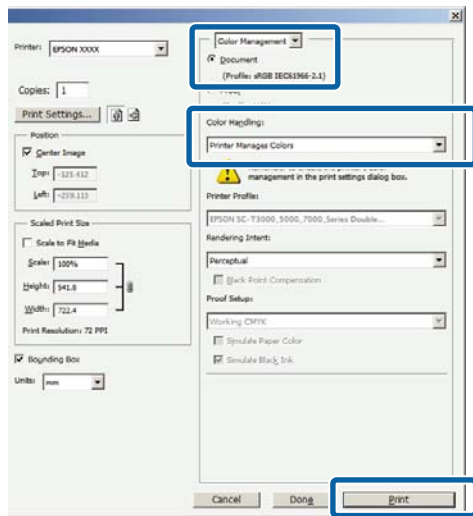

When using applications without a color management function, start from Step 2.

- 2 Clear the **Simple Settings** checkbox in **Print Quality** on the printer driver's **Printer Settings** screen, select **ICM**, and then click **Settings**.

[“Basic Printing Methods\(Windows\)” on page 70](#)

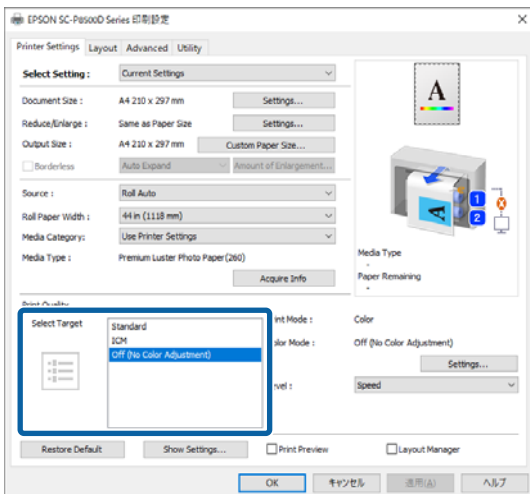

- 3 Select **ICM Mode** in **Printer Color Adjustment**. See the printer driver help for more details.

When you select genuine Epson paper in **Media Type** on the **Printer Settings** screen, the printer profile corresponding to the paper is automatically specified and displayed in the **Printer Profile Description** column.

To change the profile, select the **Show all profiles** check box.

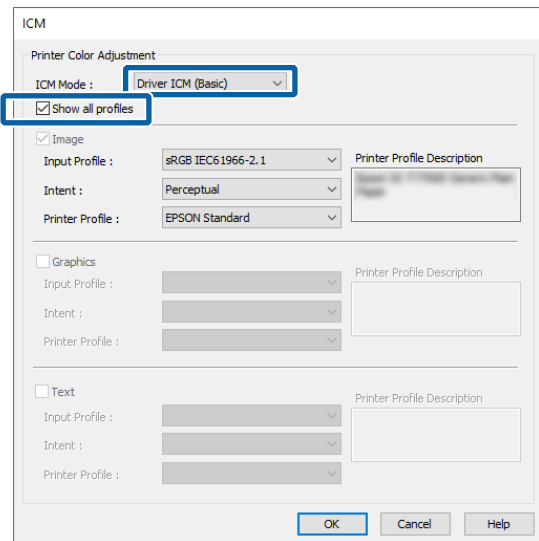

- 4 Check other settings, and then start printing.

## Color Management Printing by ColorSync (Mac)

Use image data in which an input profile has been embedded. The application must also support ColorSync.

**Note:**  
Depending on the application, color management printing by **ColorSync** may not be supported.

- 1 Disable the color management functions in the application.
- 2 Display the **Print** screen.  
[“Basic Printing Methods\(Mac\)” on page 73](#)

## Color Management Printing

- 3** Select **Color Matching** from the list, and then click **ColorSync**.

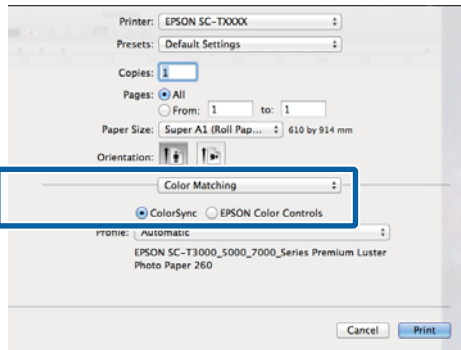

- 4** Select **Printer Settings** from the list, and then select **Advanced Settings** in **Mode Settings**. Also, set the **Color Mode** to **Off (No Color Adjustment)**.

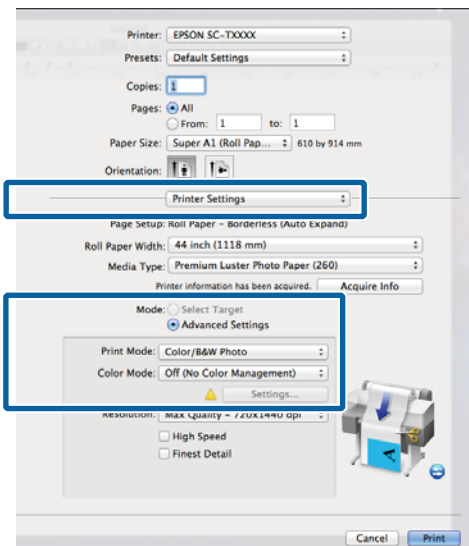

- 5** Check other settings, and then start printing.

## Color Management Printing by Driver ICM (Windows only)

The printer driver uses its own printer profiles to perform color management. You can use the following two color correction methods.

- Driver ICM (Basic)  
Specify one type of profile and intent for processing the entire image data.
- Driver ICM (Advanced)  
The printer driver distinguishes between **Image**, **Graphics**, and **Text** areas in the image data, and

then specifies a different profile and intent for each of the three areas.

### When using applications featuring a color management function

Make the settings for color processing using the application before making printer driver settings.

Depending on the type of the application, make the settings following the table below.

Adobe Photoshop CS3 or later  
 Adobe Photoshop Elements 6 or later  
 Adobe Photoshop Lightroom 1 or later

OS	Color Management Settings
Windows 11, Windows 10, Windows 8.1, Windows 8, Windows 7, Windows Vista	Printer Manages Colors
Windows XP (Service Pack 2 or later and .NET 3.0 or later)	
Windows XP (other than the above)	No Color Management

In other applications, set **No Color Management**.

**Note:**

For information on supported platforms, see the website for the application in question.

Setting example for Adobe Photoshop CS5

Open the Print dialog box.

## Color Management Printing

Select **Color Management** and then **Document**.  
Select **Printer Manages Colors** as the **Color Handling** setting, and then click **Print**.

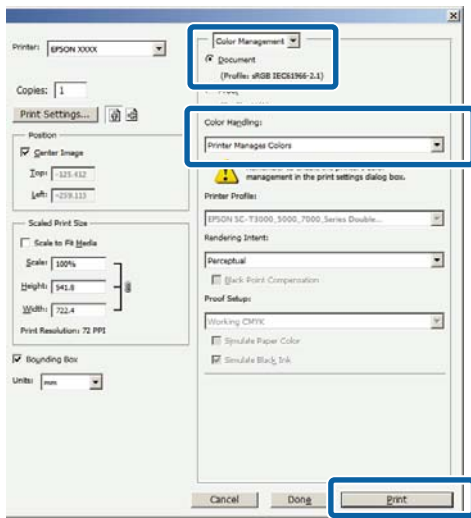

1 On the printer driver's Printer Settings screen, select **ICM** in **Print Quality**, and then click **Settings** in **Color Mode**.

[“Basic Printing Methods\(Windows\)” on page 70](#)

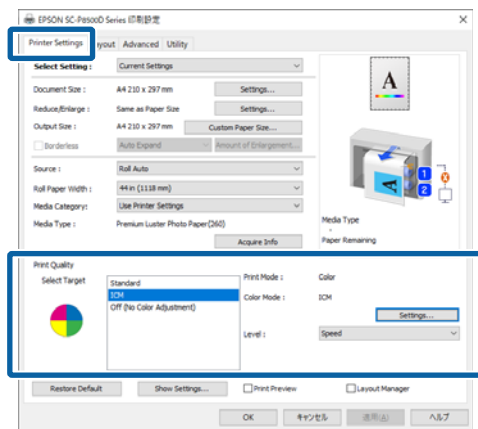

2 From **ICM Mode** on the ICM screen, select **Driver ICM (Basic)** or **Driver ICM (Advanced)**.

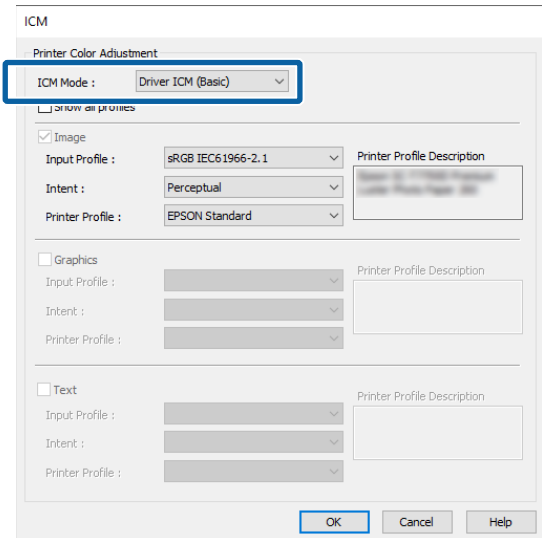

If you select **Driver ICM (Advanced)**, you can specify the profiles and intent for each image such as photos, graphics, and text data.

Intent	Explanation
Saturation	Keeps the current saturation unchanged and converts the data.
Perceptual	Converts the data so that a more visually natural image is produced. This feature is used when a wider gamut of color is used for image data.
Relative Colorimetric	Converts the data so that a set of color gamut and white point (or color temperature) coordinates in the original data match their corresponding print coordinates. This feature is used for many types of color matching.
Absolute Colorimetric	Assigns absolute color gamut coordinates to the original and print data and converts the data. Therefore, color tone adjustment is not performed on any white point (or color temperature) for the original or print data. This feature is used for special purposes such as logo color printing.

3 Check other settings, and then start printing.

## Using the Printer Driver(Windows)

# Using the Printer Driver (Windows)

## Displaying the Settings Screen

You can access the printer driver in the following ways:

- From Windows applications  
 [“Types of Borderless Printing Methods” on page 96](#)
- With the Start button

### With the Start button

Follow the steps below when specifying common settings among applications or performing printer maintenance, such as Print Head Nozzle Check or Print Head Cleaning.

- 1** On the **Control Panel** click **Hardware and Sound** and then **View devices and printers**.

**Windows 11/10/8.1/8/7**

Click **Hardware and Sound** (or **Hardware**) and then **View devices and printers** (or **Devices and Printers**).

**For Windows Vista**

Click , **Control Panel**, **Hardware and Sound**, and then **Printer**.

**For Windows XP**

Click **Start**, **Control Panel**, **Printers and Other Hardware**, and then **Printers and Faxes**.

**Note:**

*If your Windows XP Control Panel is in **Classic View**, click **Start**, **Control Panel**, and then **Printers and Faxes**.*

- 2** Right-click your printer icon, and click **Printing preferences**.

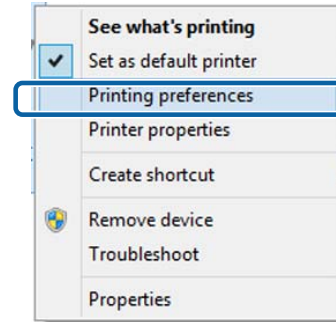

The printer driver setting screen is displayed.

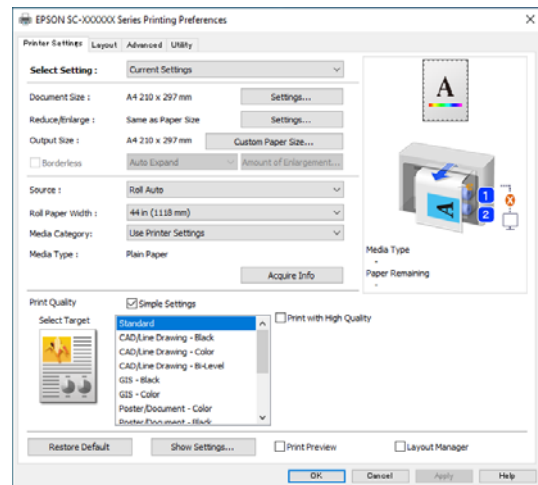

Make the necessary settings. These settings become the default settings of the printer driver.

## Using the Printer Driver(Windows)

### Displaying Help

You can access the printer driver help in the following ways:

- Click **Help**
- Right-click on the item you want to check and display

### Click the Help Button to Display

By displaying help, you can use the contents page or keyword search to read the help.

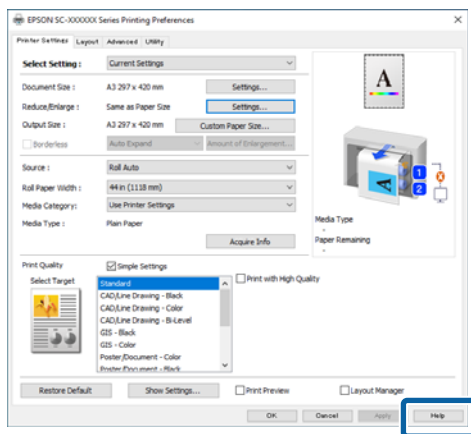

### Right-click on the item you want to check and display

Right-click the item, and then click **Help**.

**Note:**

*In Windows XP, click  on the title bar, and then click the item you want to know more about to display the help.*

## Using the Printer Driver(Windows)

# Customizing the Printer Driver

You can save the settings or change the display items as you prefer.

## Saving various settings as your Select Settings

You can save all printer driver settings as a Select Setting. Additionally, in Select Setting the recommended settings for a variety of uses are already available.

This allows you to easily load settings that have been stored in Select Settings, and repeatedly print using exactly the same settings.

**1** Set each item for the **Printer Settings** screen and the Page Setup screen that you want to save as your Select Settings.

**2** Select **Select Setting - Custom Settings**.

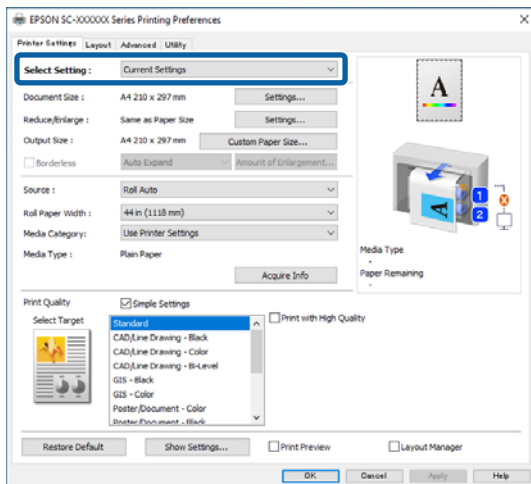

**3** When you enter a name in **Name** and click **Save**, the settings are saved in **List**.

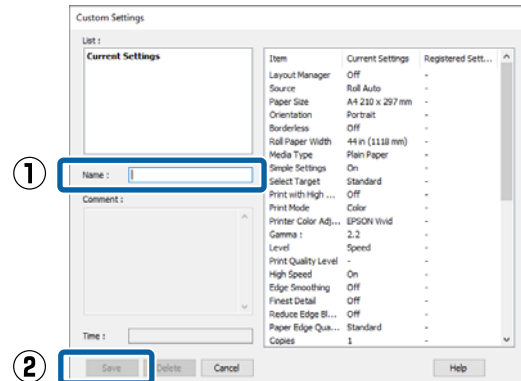

You can load the settings you have saved from **Select Setting** on the Printer Settings screen.

### Note:

- You can save up to 100 settings.
- Select the settings you want to save, and then click **Export...** to save them to a file. You can share the settings by clicking **Import...** to import the saved file on another computer.
- Select the settings you want to delete, and then click **Delete**.

## Using the Printer Driver(Windows)

# Summary of the Utility Tab

You can perform the following maintenance functions from the printer driver's **Utility** tab.

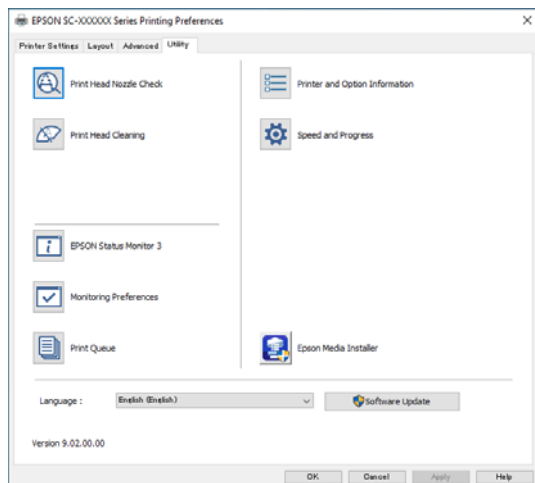

### Print Head Nozzle Check

This function prints a nozzle check pattern to check if the print head nozzles are clogged.

If you see banding or gaps in the print outs, perform head cleaning to clear any clogged nozzles.

[🔗 “Print Head Nozzle Check” on page 172](#)

### Print Head Cleaning

If you see banding or gaps in the print outs, perform head cleaning. Cleans the surface of the print head to improve the print quality.

[🔗 “Print Head Cleaning” on page 173](#)

### EPSON Status Monitor 3

You can check the printer's status, such as the remaining ink level and error messages, on the computer's screen.

### Monitoring Preferences

You can select the error notifications displayed on the EPSON Status Monitor 3 screen, or register a shortcut for the Utility icon to the taskbar.

#### Note:

If you select **Shortcut Icon** on the **Monitoring Preferences** screen, the **Utility** shortcut icon is displayed on the Windows taskbar.

By right-clicking the icon, you can display the following menu and perform maintenance functions.

EPSON Status Monitor 3 starts when the printer name is clicked from the displayed menu.



### Print Queue

You can display the list of all waiting jobs.

On the Print Queue screen, you can view information on the data waiting to be printed, delete and reprint these jobs.

### Printer and Option Information

Displays the inkset information. These settings should not normally be changed.

If you cannot acquire inkset information automatically, select an inkset according to the ink type that is installed in the printer.

### Speed and Progress

You can set various functions for printer driver basic operations.

### Epson Media Installer

If the paper information you want to use is not displayed on the control panel or in the driver, you can add paper information from the Internet.

## Using the Printer Driver(Mac)

# Using the Printer Driver (Mac)

## Displaying the Settings Screen

The display method of the printer driver setting screen may differ depending on the application or the OS version.

## Displaying Help

Click  in the printer driver setting screen to display Help.

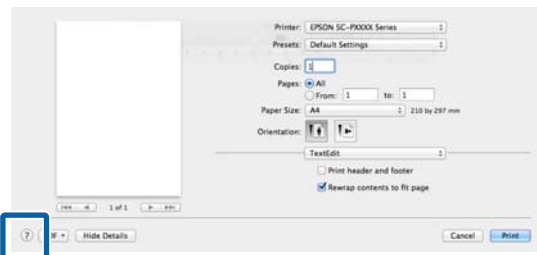

## Using Presets

You can adjust the ink density according to the paper being used, and then save the settings for future use.

## Saving Presets

- 1 Set each item for Paper Size and Print Settings to the values you want to save as a preset.  
Select **Paper Configuration** from the list and set the ink density according to the paper being used.

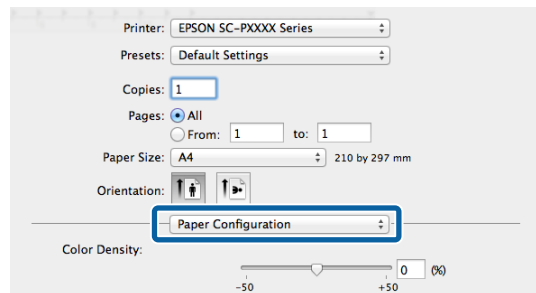

- 2 Click **Save Current Settings as Preset...** in Presets.

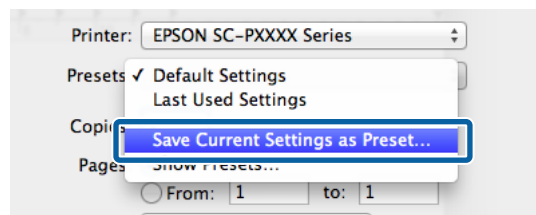

- 3 Enter a name, and then click **OK**.

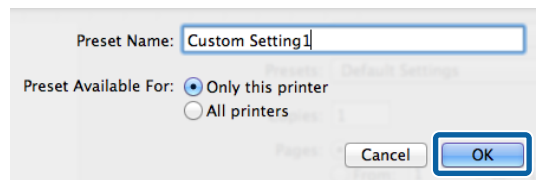

**Note:**  
If you select **All Printers** in **Target Presets**, you can select the Presets you saved from all of the printer drivers installed on your computer.

The settings are saved to the **Presets**.

You can now select the settings saved in the **Presets**.

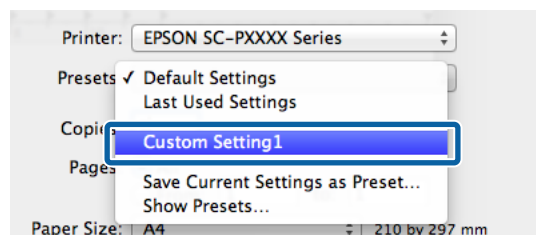

## Using the Printer Driver(Mac)

### Deleting Presets

- 1 Click **Show Presets...** in **Presets** on the Print screen.

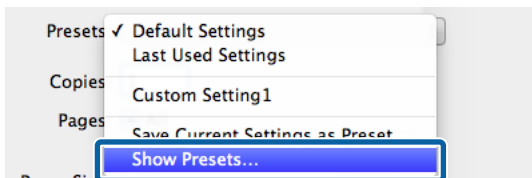

- 2 Select the settings you want to delete, click **Delete**, and then click **OK**.

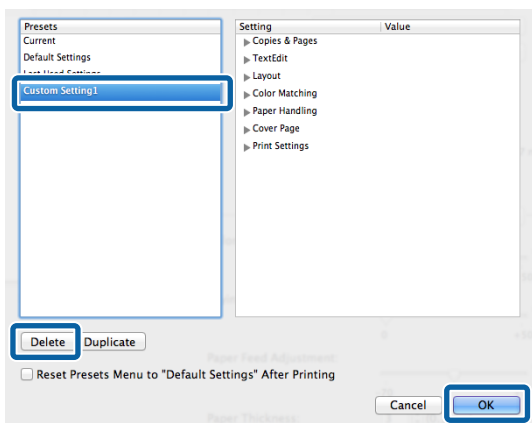

### Using Epson Printer Utility 4

You can perform maintenance functions such as nozzle checks and print head cleaning from Epson Printer Utility 4. This utility is installed automatically when you install the printer driver.

#### Starting Epson Printer Utility 4

- 1 Click **System Preferences - Printers & Scanners** (or **Print & Fax**) from the Apple menu.
- 2 Select the printer and click **Options & Supplies - Utility - Open Printer Utility**.

#### Epson Printer Utility 4 Functions

You can perform the following maintenance functions from Epson Printer Utility 4.

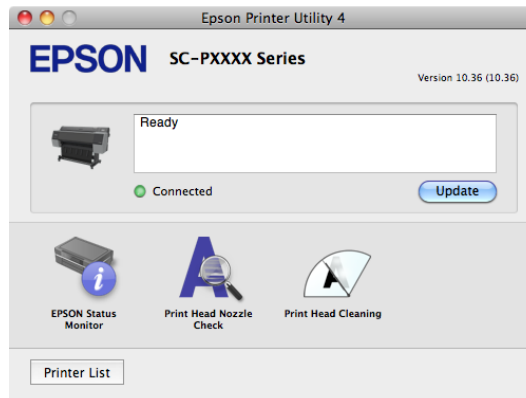

##### EPSON Status Monitor

You can check the printer's status, such as the remaining ink level and error messages, on the computer's screen.

##### Print Head Nozzle Check

This function prints a nozzle check pattern to check if the print head nozzles are clogged.

If you see banding or gaps in the print outs, perform head cleaning to clear any clogged nozzles.

 ["Print Head Nozzle Check" on page 172](#)

## Using the Printer Driver(Mac)

### Print Head Cleaning

If you see banding or gaps in the print outs, perform head cleaning. Cleans the surface of the print head to improve the print quality.

 [“Print Head Cleaning” on page 173](#)

**Copy (SC-P8500DM Series/SC-T7700DM Series/SC-T5700DM Series Only)**

# Copy (SC-P8500DM Series/SC-T7700DM Series/SC-T5700DM Series Only)

## Placing Documents in the Scanner

You can load one document.

The document sizes and paper types that can be loaded and the documents that cannot be loaded are as follows.

**! Important:**

*If a document covered in dust is loaded, the dust may adhere inside the scanner and decrease the quality of copied or scanned images. Before loading a document into the scanner, remove any dust from the document.*

## Loadable Document Sizes

Original Size : Maximum 914.4 x 30480 mm

: Minimum 148.0 x 148.0 mm

Document thickness : 0.06 to 0.8 mm

### Copy

Color/B&W

Print Quality	With Skew Correction	Without Skew Correction
Super Fine	2747 mm	
Fine	2747 mm	
Speed	5494 mm	

Print Quality	With Skew Correction	Without Skew Correction
Draft	5494 mm	

### Scan

TIFF: Monochrome binary (B&W)

Output resolution	With Skew Correction	Without Skew Correction
600 dpi	2749 mm	30480 mm
400 dpi	4129 mm	30480 mm
300 dpi	5509 mm	30480 mm
200 dpi	8269 mm	30480 mm

JPEG: Color/B&W

Output resolution	With Skew Correction	Without Skew Correction
600 dpi	2747 mm	2747 mm
400 dpi	4120 mm	4120 mm
300 dpi	5494 mm	5494 mm
200 dpi	8241 mm	8241 mm

PDF: Color/B&W

Output resolution	With Skew Correction	Without Skew Correction
600 dpi	2747 mm	2747 mm
400 dpi	4120 mm	4120 mm
300 dpi	5494 mm	5494 mm
200 dpi	8241 mm	8241 mm

## Loadable Paper Types

- Plain Paper
- Recycled
- Coated paper
- Tracing Paper

**Copy (SC-P8500DM Series/SC-T7700DM Series/SC-T5700DM Series Only)**

- Film
- Blueprint
- Actual printing stock
- Carrier sheet

**! Important:**

*If tracing paper is loaded, the printer cannot automatically detect the width. On the control panel, set **Original Size** or **Scan Size**.*

 [“Copy \(SC-P8500DM Series/SC-T7700DM Series/SC-T5700DM Series Only\)” on page 163](#)

 [“Scan \(SC-P8500DM Series/SC-T7700DM Series/SC-T5700DM Series Only\)” on page 164](#)

**When loading documents that are thin, that are easily torn, or that you do not want to damage**

Use the optional carrier sheet for thin documents and documents that you do not want to damage.

 [“Options and Consumable Products” on page 214](#)

**Documents That Cannot Be Loaded**

Do not load originals such as the following. Failure to observe this precaution could cause paper jams or damage the printer.

- Originals that are bound
- Originals that are bent
- Originals with carbon backing
- Originals that are attached with staples, paper clips, or glue
- Originals that have many holes, such as loose leaf paper
- Originals that are shaped irregularly or not cut at right angles
- Originals with photos, stickers, or labels attached
- Originals that are transparent
- Originals that are glossy
- Originals that have become deteriorated
- Originals that are torn

## Copy (SC-P8500DM Series/SC-T7700DM Series/SC-T5700DM Series Only)



### Important:

#### Notes on Using the Carrier Sheet

When scanning using a carrier sheet, the paper color (background color) of the document may remain in the scan results, or wrinkle shadows may appear.

If you are concerned about these issues, try making adjustments in **Remove Background**.

#### Removing the background

- ❑ **When copying**  
Select **Copy - Advanced - Image Quality - Remove Background - Auto - Off** on the Home screen, and then set the adjustment value to a positive value between -4 to 4.  
 “Copy (SC-P8500DM Series/SC-T7700DM Series/SC-T5700DM Series Only)” on page 163
- ❑ **When scanning and saving to an email or folder**  
Select **Scan** on the Home screen, and then select **Email** or **Network Folder/FTP** depending on the target location.  
Select **Scan Settings - Image Quality - Remove Background - Auto - Off**, and then set the adjustment value to a positive value between -4 to 4.  
 “Scan (SC-P8500DM Series/SC-T7700DM Series/SC-T5700DM Series Only)” on page 164
- ❑ **When saving scanned data to an external memory device**  
Select **Scan - To Memory Device - Advanced - Image Quality - Remove Background - Auto - Off** on the Home screen, and then set the adjustment value to a positive value between -4 to 4.  
 “Scan (SC-P8500DM Series/SC-T7700DM Series/SC-T5700DM Series Only)” on page 164

## Documents That Need the Carrier Sheet

- ❑ Valuable documents that you do not want to damage (documents on loan, master copies, old drawings, antique maps, works of art, etc.)

- ❑ Documents with fragile surfaces and/or materials (collages, newspapers, rice paper, oil pastel drawings, etc.)
- ❑ Transparent and translucent film

## Notes for When Putting Documents into the Carrier Sheet

Insert the document in the carrier sheet as shown.

- ❑ Insert the document with the side to be scanned facing the transparent sheet.
- ❑ Align the top edge of the document with part **A** of the carrier sheet.
- ❑ Align the side of the document with line **B**.

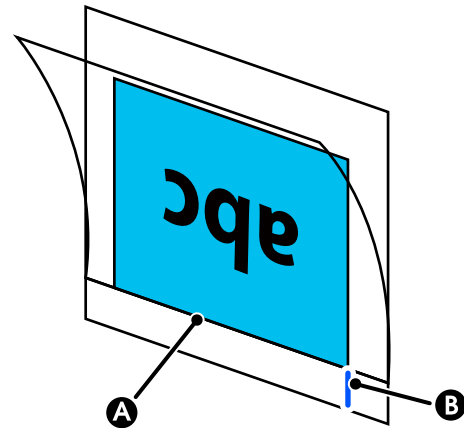

### Important:

If the carrier sheet is loaded, the printer cannot automatically detect the width. On the control panel, set **Original Size** or **Scan Size**. Or, set **Top Offset** to 19 mm.

 “Copy (SC-P8500DM Series/SC-T7700DM Series/SC-T5700DM Series Only)” on page 163

 “Scan (SC-P8500DM Series/SC-T7700DM Series/SC-T5700DM Series Only)” on page 164

**Copy (SC-P8500DM Series/SC-T7700DM Series/SC-T5700DM Series Only)**

# Procedure for Copying

**Important:**

- ❑ If the original tends to curl, load the original after straightening the curl.
- ❑ Smooth the creases in the original, and then load it.

**Note:**

For a document longer than 1 meter, support the document with your hand so it does not skew as it feeds.

**1** Load paper into the printer, and then make settings for the loaded paper.

🔗 “Setting Loaded Paper” on page 56

**2** Touch **Copy** on the Home screen.

The scanner slot opens automatically. If it does not open, place your hand in the position shown in the figure to open it.

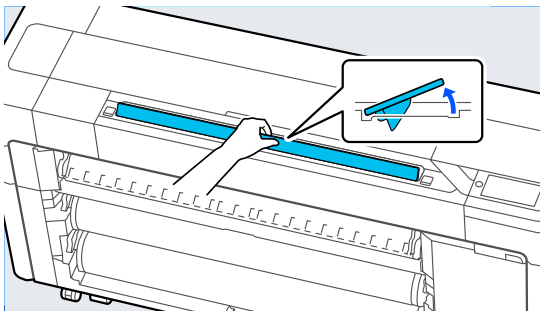

**3** During standard scanning (without using a carrier sheet), align the right edge of the document with the position shown in the figure.

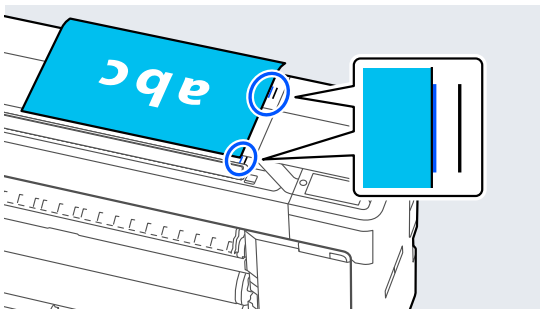

When using a carrier sheet, align the right edge of the document with the position shown in the figure.

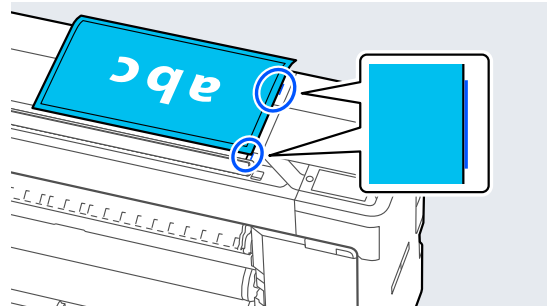

**4** With the side to be scanned facing up, insert the document into the scanner slot.

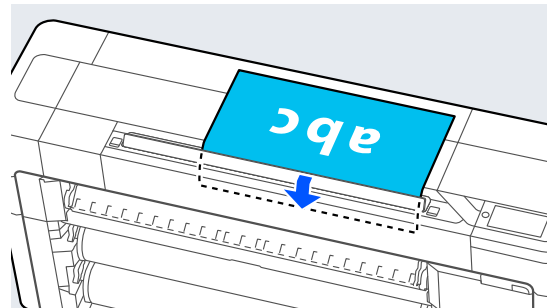

**Note:**

Store the scanner edge guide when you open the scanner cover. If the document is not fed straight, use the scanner edge guide.



When loaded



**Copy (SC-P8500DM Series/SC-T7700DM Series/SC-T5700DM Series Only)**

- 5** In **Basic Settings**, do the settings for Color, Print Quality, Density, and Reduce/Enlarge.  
If you are doing detailed settings, such as Original Type, do the settings from **Advanced**.  
If you are using the optional carrier sheet, you must do the following settings in **Advanced**.
- Specify a user defined size as the **Original Size**.
  - Set **Top Offset** to 19 mm.
- 6** Press the numeric value for the number of prints and then enter the number of prints in the keypad screen.
- 7** Press the **Copy** button to start scanning the document.

**! Important:**

*Do not press down on the scanner cover or place anything on top of it while copying.  
Otherwise, the copy results may be distorted or the original may get jammed.*

To avoid skewing for documents longer than 1 m, guide the document with both hands while scanning.



- 8** Remove the original when scanning is complete.  
While holding the original, press the **OK** button on the screen, and then remove the original.

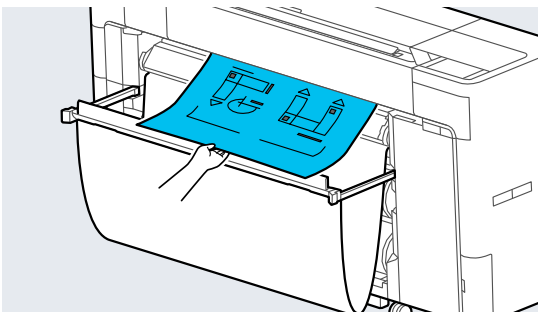

Printing starts when the original has been completely removed.

## Scan (SC-P8500DM Series/SC-T7700DM Series/SC-T5700DM Series Only)

# Scan (SC-P8500DM Series/SC-T7700DM Series/SC-T5700DM Series Only)

## Function Summary

The following are 5 ways that you can save or send the data of scanned images.

**Network Folder/FTP:** Save the scanned image in a folder through the network. For the recipient, you can specify a shared folder (a folder that uses SMB protocol) that was created on a computer or a folder on the FTP server. You must do the settings for the shared folder or FTP server in advance.

**Email:** Attach the scanned image directly into an email to be able to send it from the printer. You must register an email server and do its settings in advance.

**Computer:** Save the scanned image to the specified computer. Install "Document Capture Pro" or "Document Capture" and "Epson Scan 2" on your computer. See the *Administrator's Guide* for more details on how to make settings in "Document Capture Pro". See the following for details on how to save scanned images to your computer.

[📄 "Saving Scanned Images to Your Computer" on page 136](#)

**Memory Device:** You can save the scanned image to a USB flash memory that is installed in the printer. You do not have to do any settings in advance.

**Storage:** Scanned images are saved to the built-in SSD Unit.

## Preparing to Scan

The following settings must be done in advance to save a scanned image to a folder or send a scanned image via email.

- Shared folder settings and FTP server settings  
Set up in Web Config. See the *Administrator's Guide* for more details.
- Mail server settings  
Set up in Web Config. See the *Administrator's Guide* for more details.
- Settings for the recipient email addresses and the contacts for the shared folder  
Do the settings from the printer's screen or from Web Config. This section explains the contacts settings in the shared folder from the printer's screen. See the *Administrator's Guide* for more details on how to make settings in Web Config.

### Creating Contacts

- 1** Press **Menu - General Settings**.
- 2** Touch, in order, **Contacts Manager - Register/Delete**.
- 3** Touch, in order, **Add Entry - Add Contact - Network Folder/FTP**.

The Add Entry screen appears.

- 4** Check the details for each item and input any necessary information.
  - Registry Number: Set a registry number for the address.
  - Name: Name that appears in your contacts (up to 30 characters).

## Scan (SC-P8500DM Series/SC-T7700DM Series/SC-T5700DM Series Only)

- ❑ **Index Word:** Use to search your contacts (up to 30 characters).
- ❑ **Communication Mode:** Select SMB.
- ❑ **Store to:** Enter a shared folder's network path (within 255 characters). When you enter letters, numbers, and symbols, specify single-byte and double-byte characters correctly. If the setting for single-byte and double-byte characters is incorrect, you will not be able to save to the shared folder.
- ❑ **User Name:** Enter the user name that you use to log into the computer.
- ❑ **Password:** Enter the password that you use to log into the computer.
- ❑ **Assign to Frequent Use:** Register an address for frequent use. When an address is specified, it will appear on the top screen.

**Note:**

If you do not have a password set on your computer, you do not have to enter a user name or password.

- 5** Touch **OK** to finish registering a shared folder to your contacts.

## Procedure for Scanning

Advance settings vary depending on where the scanned image will be saved. Customize settings in advance if necessary.

 [“Preparing to Scan” on page 134](#)

**Note:**

First, check that the printer's **Date/Time** and **Time Difference** are set correctly. From the control panel, select, in order, **Settings - General Settings - Basic Settings - Date/Time Settings**.

- 1** Press **Scan** on the Home screen, and then select the location.

The scanner slot opens automatically. If it does not open, place your hand in the position shown in the figure to open it.

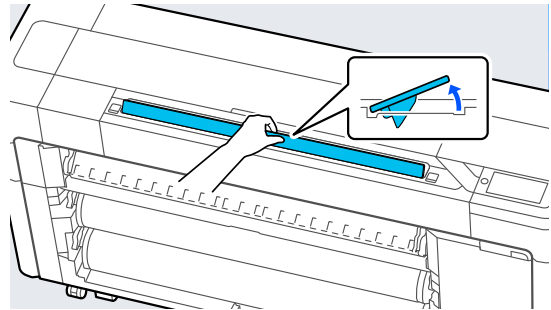

- 2** During standard scanning (without using a carrier sheet), align the right edge of the document with the position shown in the figure.

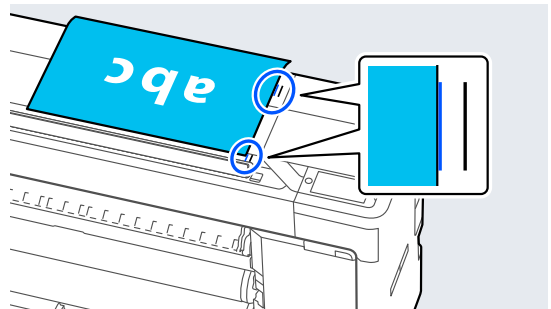

When using a carrier sheet, align the right edge of the document with the position shown in the figure.

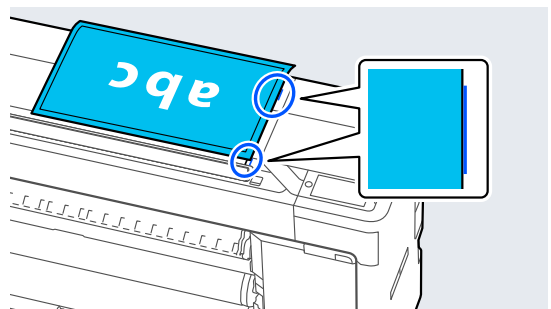

**Scan (SC-P8500DM Series/SC-T7700DM Series/SC-T5700DM Series Only)**

- 3** With the side to be scanned facing up, insert the document into the scanner slot.

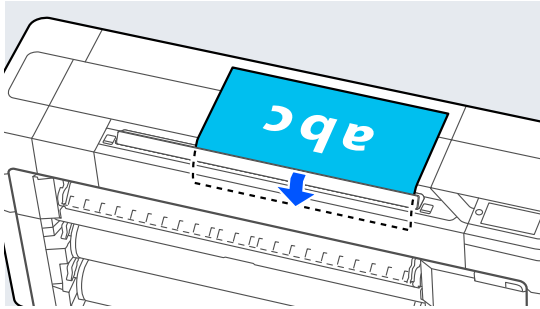

**Note:**

Store the scanner edge guide when you open the scanner cover. If the document is not fed straight, use the scanner edge guide.



When loaded



- 4** Touch **Scan Settings**, and then do the settings for scanning.  
 Select settings, such as the Color Mode and the File Format.  
 If you are using the optional carrier sheet, you must do the following settings.
  - Specify a user defined size as the **Scan Size**.
  - Set **Top Offset** to 19 mm.

- 5** Press the **Store** button to start scanning.

**! Important:**

Do not press down on the scanner cover or place anything on top of it while scanning.

Otherwise, the scan results may be distorted or the original may get jammed.

To avoid skewing for documents longer than 1 m, guide the document with both hands while scanning.



- 6** Remove the original when scanning is complete.

While holding the original, press the **OK** button on the screen, and then remove the original.

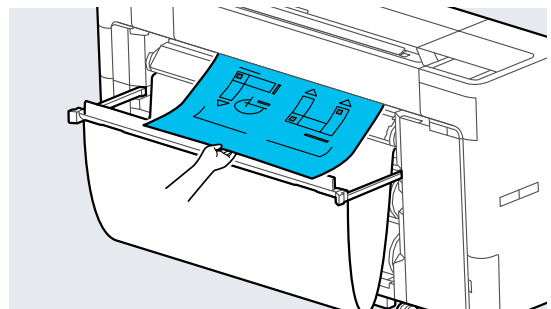

**! Important:**

If scanning is performed while printing, the original is not supported. Hold the original so that it does not fall.

## Saving Scanned Images to Your Computer

**Note:**

First, check that the printer's **Date/Time** and **Time Difference** are set correctly. From the control panel, select, in order, **Settings - General Settings - Basic Settings - Date/Time Settings**.

## Scan (SC-P8500DM Series/SC-T7700DM Series/SC-T5700DM Series Only)

- 1** Press **Scan - To Computer** on the Home screen.
- 2** Select the computer on which "Document Capture Pro" is installed.  
The scanner slot opens.
- 3** Scan the original.  
 ["Procedure for Scanning" on page 135](#)

## Menu List

# Menu List

## Paper Setting

Item	Setting/Additional Explanation
Roll 1 (Known as Roll Paper on the SC-P6500E Series/SC-T3700E Series)	
Remove	Roll paper is ejected. After the paper has been ejected, information on how to remove the roll paper is displayed.
Feed/Cut Paper	Use <b>Backward</b> and <b>Forward</b> to adjust the amount of paper being fed. Press Cut to cut the paper.

### Menu List

Item	Setting/Additional Explanation
Print Adjustments	
Automatic Adjustment	
Standard	Automatically performs <b>Paper Feed Adjust</b> and <b>Ruled Line Alignment</b> .
Details	Select this if you are not satisfied with the adjustments made by <b>Automatic Adjustment - Standard</b> , or if you want to perform <b>Automatic Adjustment</b> to match your printing needs. Select the items that suit your printing needs in <b>Select Target</b> and <b>Print Quality</b> .
Paper Feed Adjust	
Auto	Use this menu when Automatic Adjustment cannot be performed, or when banding (horizontal banding, tint unevenness, or stripes) is detected in printing results.
Manual	<p>Quality First, Length Accuracy First</p> <p>Select the following if you are not satisfied with the adjustments made by <b>Paper Feed Adjust - Auto</b>, or if you want to perform <b>Paper Feed Adjust</b> to match your printing needs.</p> <p><b>Quality First</b> is suitable for printing images that require an emphasis on image quality. Make adjustments while visually checking the adjustment patterns.</p> <p><b>Length Accuracy First</b> is suitable for printing images that require an emphasis on dimensions and length such as CAD. Measure and adjust the distance of the printed measurement positions.</p>
Ruled Line Alignment	
Auto(Standard)	Use this menu when Automatic Adjustment cannot be performed, or when the ruled lines are misaligned or if there is graininess in the printing results.
Auto(Details)	Use this menu if you are not satisfied with the results of adjustment performed by <b>Ruled Line Alignment - Auto(Standard)</b> or when ruled lines are misaligned at the edge of the paper.
Manual(Standard)	Use this menu if you are not satisfied with the results of adjustment performed by <b>Ruled Line Alignment - Auto</b> . Visually inspect the printed pattern and enter the measurements to perform adjustments.
Manual(Details)	Use this menu if you are not satisfied with the adjustments made by <b>Ruled Line Alignment - Auto</b> or <b>Manual(Standard)</b> , or if you want to perform <b>Ruled Line Alignment</b> to match your printing needs. Select the items that suit your printing needs in <b>Select Target</b> and <b>Print Quality</b> , and the pattern is printed. Make adjustments while visually checking the adjustment patterns.

### Menu List

Item	Setting/Additional Explanation
Advanced Paper Settings	
Confirm ICC profile (Except for models without the Adobe PS3 Expansion Unit)	The ICC profile name is displayed when using paper with custom paper settings.
Confirm Color Density (Except for models without the Adobe PS3 Expansion Unit)	The ink density is displayed when using paper with custom paper settings. The ink density cannot be changed.
Paper Thickness	0.01 - 1.50 mm (0.01 mm units)/0.4 - 59.1 mil (0.1 mil units) This item is only displayed for custom paper settings.
Platen Gap	Auto, 1.2, 1.6, 1.9, 2.1, 2.4 Select a wider setting if print results are scratched or smudged.
Top/Bottom Margins	Standard, Top 3 mm/Bottom 3 mm, Top 15 mm/Bottom 15 mm, Top 20 mm/Bottom 15 mm, Top 45 mm/Bottom 15 mm When you select <b>Standard</b> , the margins are set automatically according to the paper.
Paper Suction	-3 - +3
Paper Size Check	On, Off When this is set to <b>On</b> , the width of the loaded roll paper is automatically detected.
Auto Cut	Follow Paper Source Settings, Never Cut
Roll Core Diameter	2inch, 3inch Set the paper core size for the roll paper being loaded.
Paper Eject Roller	Auto, Use, Do Not Use
Paper Feed Offset	-1.0 - +1.50% This item is only displayed for custom paper settings.
Restore Default Settings	This item is only displayed for standard media settings. Restores advanced settings to their default settings. The advanced paper settings are saved for the paper type. When printing is complete, the default settings are restored.
Remaining Amount Management	
Remaining Amount Management	On, Off
Remaining Amount	Enter the amount of paper remaining.
Remaining Alert	A warning is displayed when the amount of remaining roll paper is running low. Enter the amount of remaining roll paper that will trigger the warning.
Change Paper Type (or Change Paper Type/Paper Width)	
Paper Type	Recently Used Paper, Recently Added Media, More Paper Types
Paper Width	A Series, US-ANSI, US-ARCH, B Series (ISO), B Series (JIS), Photo Series, Others, User Defined

## Menu List

Item	Setting/Additional Explanation
Roll 2 (except for the SC-P6500E Series/SC-T3700E Series)	
Remove	Roll paper is ejected. After the paper has been ejected, information on how to remove the roll paper is displayed.
Feed/Cut Paper	Press Cut to cut the paper.
Prepare for Take-up	Press when using the auto take-up function. See the following for more information.  <a href="#">"Loading Method for Auto Take-up" on page 64</a>
Print Adjustments	
Automatic Adjustment	
Standard	Automatically performs <b>Paper Feed Adjust</b> and <b>Ruled Line Alignment</b> .
Details	Select this if you are not satisfied with the adjustments made by <b>Automatic Adjustment - Standard</b> , or if you want to perform <b>Automatic Adjustment</b> to match your printing needs. Select the items that suit your printing needs in <b>Select Target</b> and <b>Print Quality</b> .
Paper Feed Adjust	
Auto	Use this menu when Automatic Adjustment cannot be performed, or when banding (horizontal banding, tint unevenness, or stripes) is detected in printing results.
Manual	Quality First, Length Accuracy First Select the following if you are not satisfied with the adjustments made by <b>Paper Feed Adjust - Auto</b> , or if you want to perform <b>Paper Feed Adjust</b> to match your printing needs. <b>Quality First</b> is suitable for printing images that require an emphasis on image quality. Make adjustments while visually checking the adjustment patterns. <b>Length Accuracy First</b> is suitable for printing images that require an emphasis on dimensions and length such as CAD. Measure and adjust the distance of the printed measurement positions.
Ruled Line Alignment	
Auto(Standard)	Use this menu when Automatic Adjustment cannot be performed, or when the ruled lines are misaligned or if there is graininess in the printing results.
Auto(Details)	Use this menu if you are not satisfied with the results of adjustment performed by <b>Ruled Line Alignment - Auto(Standard)</b> or when ruled lines are misaligned at the edge of the paper.
Manual(Standard)	Use this menu if you are not satisfied with the results of adjustment performed by <b>Ruled Line Alignment - Auto</b> . Visually inspect the printed pattern and enter the measurements to perform adjustments.
Manual(Details)	Use this menu if you are not satisfied with the adjustments made by <b>Ruled Line Alignment - Auto</b> or <b>Manual(Standard)</b> , or if you want to perform <b>Ruled Line Alignment</b> to match your printing needs. Select the items that suit your printing needs in <b>Select Target</b> and <b>Print Quality</b> , and the pattern is printed. Make adjustments while visually checking the adjustment patterns.

## Menu List

Item	Setting/Additional Explanation
Advanced Paper Settings	
Confirm ICC profile (Except for models without the Adobe PS3 Expansion Unit)	The ICC profile name is displayed when using paper with custom paper settings.
Confirm Color Density (Except for models without the Adobe PS3 Expansion Unit)	The ink density is displayed when using paper with custom paper settings. The ink density cannot be changed.
Paper Thickness	0.01 - 1.50 mm (0.01 mm units)/0.4 - 59.1 mil (0.1 mil units)
Platen Gap	Auto, 1.2, 1.6, 1.9, 2.1, 2.4 Select a wider setting if print results are scratched or smudged.
Top/Bottom Margins	Standard, Top 3 mm/Bottom 3 mm, Top 15 mm/Bottom 15 mm, Top 20 mm/Bottom 15 mm, Top 45 mm/Bottom 15 mm When you select <b>Standard</b> , the margins are set automatically according to the paper.
Paper Suction	-3 - +3
Paper Size Check	On, Off When this is set to <b>On</b> , the width of the loaded roll paper is automatically detected.
Auto Cut	Follow Paper Source Settings, Never Cut
Roll Core Diameter	2inch, 3inch Set the paper core size for the roll paper being loaded.
Paper Eject Roller	Auto, Use, Do Not Use
Paper Feed Offset	-1.0 - +1.50% This item is only displayed for custom paper settings.
Restore Default Settings	Restores advanced settings to their default settings. The advanced paper settings are saved for the paper type. When printing is complete, the default settings are restored.
Remaining Amount Management	
Remaining Amount Management	On, Off
Remaining Amount	Enter the amount of paper remaining.
Remaining Alert	A warning is displayed when the amount of remaining roll paper is running low. Enter the amount of remaining roll paper that will trigger the warning.
Change Paper Type (or Change Paper Type/Paper Width)	
Paper Type	Recently Used Paper, Recently Added Media, More Paper Types
Paper Width	A Series, US-ANSI, US-ARCH, B Series (ISO), B Series (JIS), Photo Series, Others, User Defined

### Menu List

Item	Setting/Additional Explanation
Cut Sheet	
Remove	Ejects cut sheets. After the paper has been ejected, information on how to remove the cut sheets is displayed.
Print Adjustments	
Automatic Adjustment	
Standard	Automatically performs <b>Paper Feed Adjust</b> and <b>Ruled Line Alignment</b> .
Details	Select this if you are not satisfied with the adjustments made by <b>Automatic Adjustment - Standard</b> , or if you want to perform <b>Automatic Adjustment</b> to match your printing needs. Select the items that suit your printing needs in <b>Select Target</b> and <b>Print Quality</b> .
Paper Feed Adjust	
Auto	Use this menu when Automatic Adjustment cannot be performed, or when banding (horizontal banding, tint unevenness, or stripes) is detected in printing results.
Manual	Quality First, Length Accuracy First Select the following if you are not satisfied with the adjustments made by <b>Paper Feed Adjust - Auto</b> , or if you want to perform <b>Paper Feed Adjust</b> to match your printing needs. <b>Quality First</b> is suitable for printing images that require an emphasis on image quality. Make adjustments while visually checking the adjustment patterns. <b>Length Accuracy First</b> is suitable for printing images that require an emphasis on dimensions and length such as CAD. Measure and adjust the distance of the printed measurement positions.
Ruled Line Alignment	
Auto(Standard)	Use this menu when Automatic Adjustment cannot be performed, or when the ruled lines are misaligned or if there is graininess in the printing results.
Auto(Details)	Use this menu if you are not satisfied with the results of adjustment performed by <b>Ruled Line Alignment - Auto(Standard)</b> or when ruled lines are misaligned at the edge of the paper. Select the items that suit your printing needs in <b>Select Target</b> and <b>Print Quality</b> .
Manual(Standard)	Use this menu if you are not satisfied with the results of adjustment performed by <b>Ruled Line Alignment - Auto</b> . Visually inspect the printed pattern and enter the measurements to perform adjustments.
Manual(Details)	Use this menu if you are not satisfied with the adjustments made by <b>Ruled Line Alignment - Auto</b> or <b>Manual(Standard)</b> , or if you want to perform <b>Ruled Line Alignment</b> to match your printing needs. Select the items that suit your printing needs in <b>Select Target</b> and <b>Print Quality</b> , and the pattern is printed. Make adjustments while visually checking the adjustment patterns.

## Menu List

Item	Setting/Additional Explanation
Advanced Paper Settings	
Confirm ICC profile (Except for models without the Adobe PS3 Expansion Unit)	The ICC profile name is displayed when using paper with custom paper settings.
Confirm Color Density (Except for models without the Adobe PS3 Expansion Unit)	The ink density is displayed when using paper with custom paper settings. The ink density cannot be changed.
Paper Thickness	0.01 - 1.50 mm (0.01 mm units)/0.4 - 59.1 mil (0.1 mil units) This item is only displayed for Custom Paper Setting.
Platen Gap	Auto, 1.2, 1.6, 1.9, 2.1, 2.4 Select a wider setting if print results are scratched or smudged.
Paper Suction	-3 - +3 Thin or soft paper may not be fed correctly. If this occurs, reduce the setting.
Paper Size Check	On, Off When this is set to <b>On</b> , the width of the loaded paper is automatically detected.
Paper Eject Roller	Auto, Use, Do Not Use
Paper Feed Offset	-1.0 - +1.50% Displayed when using paper with custom paper settings.
Restore Default Settings	Restores <b>Advanced Paper Settings</b> to their default settings. The <b>Advanced Paper Settings</b> are saved for the paper type. When printing is complete, the default settings are restored.
Change Paper Type/Paper Size	
Paper Type	You can select the paper type.
Paper Size	A Series, US-ANSI, US-ARCH, B Series (ISO), B Series (JIS), Photo Series, Others, User Defined

### Menu List

Item	Setting/Additional Explanation
Poster Board	
Remove	Poster board is ejected. After the media has been ejected, information on how to remove the cut sheets or poster board is displayed.
Print Adjustments	
Paper Feed Adjust	
Manual	Quality First, Length Accuracy First Select the following when banding (horizontal banding, tint unevenness, or stripes) is detected in printing results. <b>Quality First</b> is suitable for printing images that require an emphasis on image quality. Make adjustments while visually checking the adjustment patterns. <b>Length Accuracy First</b> is suitable for printing images that require an emphasis on dimensions and length such as CAD. Measure and adjust the distance of the printed measurement positions.
Ruled Line Alignment	
Manual(Standard)	Use this menu when Automatic Adjustment cannot be performed, or when the ruled lines are misaligned or if there is graininess in the printing results. Visually inspect the printed pattern and enter the measurements to perform adjustments.
Manual(Details)	Select the following if you are not satisfied with the adjustments made by <b>Manual(Standard)</b> , or if you want to perform <b>Ruled Line Alignment</b> to match your printing needs. Select the items that suit your printing needs in <b>Select Target</b> and <b>Print Quality</b> , and the pattern is printed. Make adjustments while visually checking the adjustment patterns.

### Menu List

Item	Setting/Additional Explanation
Advanced Paper Settings	
Confirm ICC profile (Except for models without the Adobe PS3 Expansion Unit)	The ICC profile name is displayed when using paper with custom paper settings.
Confirm Color Density (Except for models without the Adobe PS3 Expansion Unit)	The ink density is displayed when using paper with custom paper settings. The ink density cannot be changed.
Paper Thickness	0.01 - 1.50 mm (0.01 mm units)/0.4 - 59.1 mil (0.1 mil units)
Paper Suction	-3 - +3 Thin or soft paper may not be fed correctly. If this occurs, reduce the setting.
Paper Size Check	On, Off When this is set to <b>On</b> , the width of the loaded poster board is automatically detected.
Paper Feed Offset	-1.0 - +1.50% This item is only displayed for Custom Paper Setting.
Restore Default Settings	Restores <b>Advanced Paper Settings</b> to their default settings. The <b>Advanced Paper Settings</b> are saved for the paper type. When printing is complete, the default settings are restored.
Change Paper Type/Paper Size	
Paper Type	You can select the paper type.
Paper Size	A Series, US-ANSI, US-ARCH, B Series (ISO), B Series (JIS), Photo Series, Others, User Defined

## Menu List



## General Settings

Item	Setting/Additional Explanation
Basic Settings	
LCD Brightness	1 - 9
Sounds	
Button Press	0 - 10
Paper Set	0 - 10
Scanner Ready Notice (SC-P8500DM Series/SC-T7700DM Series/SC-T5700DM Series)	0 - 10
Completion Notice	0 - 10
Error Tone	0 - 10
Sound Type	Pattern1, Pattern2
Inside Light	Auto, Manual
Alert Lamp Notice	On, Off
Sleep Timer	1 to 120 minutes
Wake from Sleep	Allows you to set the method for waking from sleep mode.
Power Off Timer	Off, 30minutes, 1h, 2h, 4h, 8h, 12h This feature may not be available depending on your region.
Power Off Settings	Select this setting to turn the printer off automatically if it is not used for a specified period of time. Any increase will affect the product's energy efficiency. Please consider the environment before making any changes.
Power Off If Disconnected	Off, On Select this setting to turn the printer off after a specified period of time when all ports including the LINE port are disconnected. This feature may not be available depending on your region. See the following website for the specified period of time. <a href="https://www.epson.eu/energy-consumption">https://www.epson.eu/energy-consumption</a>
Circuit Breaker Interlock Startup	On, Off
Date/Time Settings	Date/Time, Daylight Saving Time, Time Difference
Language	Dutch, English, French, German, Italian, Japanese, Korean, Portuguese, Polish, Russian, Simplified Chinese, Spanish, Traditional Chinese

### Menu List

Item	Setting/Additional Explanation
Print Screen	Professional, Simple
Edit Home (SC-P8500DM Series/SC-T7700DM Series/ SC-T5700DM Series)	Add Icon, Delete Icon, Move Icon, Reset Icon Display
Operation Time Out	On, Off
Keyboard	QWERTY, AZERTY, QWERTZ
Length Unit	m, ft / in
Default Screen(Job/Status)	Job Status, Log, Printer Status

### Menu List

Item	Setting/Additional Explanation
Printer Settings	
Paper Source Settings	
Roll Paper Setup	
Auto Loading	<p>On, Off</p> <p>When this is set to <b>On</b>, paper is fed automatically after the paper has been loaded. When this is set to <b>Off</b>, paper is not fed automatically. Feed the paper manually.</p> <p> <a href="#">"Feeding Roll Paper Manually" on page 63</a></p>
Roll1 Function (except for the SC-P6500E Series/ SC-T3700E Series)	<p>Advance, Take-up</p> <p>When using roll 1 for take-up, select <b>Take-up</b>. When using anything else, select <b>Advance</b>.</p>
Roll Switching (except for the SC-P6500E Series/SC-T3700E Series)	
Auto	<p>Automatically switches between Roll 1 and Roll 2 for optimum printing efficiency.</p> <p>Roll paper switching conditions include the <b>Paper Type, Paper Width, and Paper Length</b>.</p> <ul style="list-style-type: none"> <li><input type="checkbox"/> Paper Type: You can select <b>Type Match</b> or <b>Disable</b>. Select <b>Type Match</b> to switch roll paper when the paper loaded in roll 1 and roll 2 match. Select <b>Disable</b> to switch roll paper even when the paper loaded in roll 1 and roll 2 does not match.</li> <li><input type="checkbox"/> Paper Width: You can select <b>Optimize Margins, Width Match, or Disable</b>. Select <b>Optimize Margins</b> to print on the roll paper with smaller margins. Select <b>Width Match</b> to print on the roll paper with the same paper width as the print job. Select <b>Disable</b> to switch the roll paper regardless of the paper width.</li> <li><input type="checkbox"/> Paper Length: You can select <b>Data Length Priority, Remaining Amount Priority, or Disable</b>. Select <b>Data Length Priority</b> to prevent the roll paper from being switched during printing. Make the remaining roll paper management settings before printing. Select <b>Remaining Amount Priority</b> to prioritize the roll paper with the least amount of paper remaining to finish off the roll before switching to the other roll paper. Select <b>Disable</b> to switch the roll paper regardless of the amount of paper remaining.</li> </ul> <p>See the following for more details on roll switching settings.</p> <p> <a href="#">"Automatically Switch Roll Paper for Printing (Except for the SC-P6500E Series/SC-T3700E Series)" on page 91</a></p>
Roll 1	<p>Select this when printing on roll 1 to prevent automatically switching the roll paper.</p>
Roll 2	<p>Select this when printing on roll 2 to prevent automatically switching the roll paper.</p>

## Menu List

Item	Setting/Additional Explanation
Print Job Priority (except for the SC-P6500E Series/ SC-T3700E Series)	Same Roll, Queued Order  Displayed when the SSD Unit is installed. When <b>Same Roll</b> is selected, priority is given to printing jobs that are suitable for the roll paper being fed. This can shorten printing time by reducing the number of roll paper changes. When Queued Order is selected, jobs are printed in the order in which they are received. Switch the roll paper according to the job you are printing.
Cut Settings	
Auto Cut	On, Off
Print Cutting Guideline	On, Off  If Auto Cut is <b>Off</b> , you can choose to print ( <b>On</b> ) or not print ( <b>Off</b> ) cut lines on roll paper. Cut lines are not printed if Auto Cut is On or when printing cut sheets or poster board.
Wait for Cut Between Pages	On, Off
Cut for Borderless Print	Two Cuts, One Cut
Quick Cut	On, Off
Cut Mode	Normal, Quiet
Margin Refresh	On, Off
Roll End Option	Continue, Stop Printing, Reprint  Select whether to print the remaining data on the replaced roll ( <b>Continue</b> ), to stop printing ( <b>Stop Printing</b> ), or print again from the beginning ( <b>Reprint</b> ). <b>Reprint</b> is only available when the SSD Unit is installed.
Take-up After Cut (except for the SC-P6500E Series/ SC-T3700E Series)	On, Off
Error Notice	
Paper Size Notice	On, Off
Paper Type Notice	On, Off
Detect Paper Skew	On, Off
Platen Gap Offset	Standard, Wide, Wider, Widest
Cut Sheet/Poster Board Slot	Front, Back
Custom Paper Setting	
01-30	Displays the registered number and registered media name. Paper setting information that has been registered using the driver or other software cannot be changed by the printer.
Change Name	Displays the media name registration screen.
Change Reference Paper	Displays the reference paper type.

### Menu List

Item	Setting/Additional Explanation
Advanced Paper Settings	
Confirm ICC profile (Except for models without the Adobe PS3 Expansion Unit)	The ICC profile name is displayed when using paper with custom paper settings.
Confirm Color Density (Except for models without the Adobe PS3 Expansion Unit)	The ink density is displayed when using paper with custom paper settings. The ink density cannot be changed.
Paper Thickness	0.01 - 1.50 mm (0.4 - 59.1 mil) (0.01 mm units)
Platen Gap	Auto, 1.2, 1.6, 1.9, 2.1, 2.4
Top/Bottom Margins	Standard, Top 3 mm/Bottom 3 mm, Top 15 mm/Bottom 15 mm, Top 20 mm/Bottom 15 mm, Top 45 mm/Bottom 15 mm  When you select <b>Standard</b> , the margins are set automatically according to the paper.
Paper Suction	Roll 1 (known as Roll on the SC-P6500E Series/SC-T3700E Series), Roll 2, Cut Sheet, Poster Board  -3 - +3  Thin or soft paper may not be fed correctly. If this occurs, reduce the setting.
Paper Size Check	On, Off  When this is set to <b>On</b> , the width of the loaded paper is automatically detected.
Auto Cut	Follow Paper Source Settings, Never Cut
Roll Core Diameter	2inch, 3inch  Set the paper core size for the roll paper being loaded.
Paper Eject Roller	Auto, Use, Do Not Use
Paper Feed Offset	Roll 1 (known as Roll on the SC-P6500E Series/SC-T3700E Series), Roll 2, Cut Sheet, Poster Board  -1.0 - +1.50%
Delete	Deletes the registered custom paper setting.
Auto Cleaning	
On	Sets the timing that you want the printer to check the status of the nozzles, and if clogged nozzles are detected, cleans the nozzles up to the set number of times. If the nozzles are not clogged, cleaning is not performed.
Standard	Sets normal automatic cleaning.
Custom	You can set the timing and frequency for auto cleaning.
Nozzle Check Schedule	During Print, After Print
Nozzle Check Sensitivity	You can set the sensitivity of the nozzle check and the maximum number of cleaning cycles.
Nozzle Check Result Notice	On, Off
Off	Turns off auto cleaning.

### Menu List

Item	Setting/Additional Explanation
Printing Language	
USB	Auto, HP-GL/2, PS (except for models without the Adobe PS3 Expansion Unit)
Network	Auto, HP-GL/2, PS (except for models without the Adobe PS3 Expansion Unit)
Universal Print Settings	
Paper Source	Roll(Auto), Roll 1 (known as Roll on the SC-P6500E Series/SC-T3700E Series), Roll 2, Cut Sheet, Poster Board
Print Quality	Standard, Draft, Speed, Fine, High Quality, Max Quality
Color Mode	Color, B&W
Page Margins option	Clip By Margins, Oversize
Page Margin	3 mm, 5 mm
Smoothing	Off, On
Base Output Size	Auto, A Series, US-ANSI, US-ARCH, B Series (ISO), B Series (JIS), Photo Series, Others, User Defined
Resolution	Standard, 300dpi, 600dpi, 1200dpi
Select Target	Poster(Photo)/Perspective (SC-P Series only), Poster/Document (SC-T Series only), GIS, CAD/Line Drawing, Off (No Color Management)
Save To Optional storage unit (Except for the SC-P8500DM Series/ SC-T7700DM Series/SC-T5700DM Series)	Print And Save, Print Only, Save Only
Save to Storage (SC-P8500DM Series/SC-T7700DM Series/SC-T5700DM Series only)	Print And Save, Print Only, Save Only
HP-GL/2 Unique Settings	
Rotate	0°, 90°, 180°, 270°
Origin Setup	Left Edge, Center
Mirror Image	On, Off
Line Merge	On, Off
Select Target	Poster(Photo)/Perspective (SC-P Series only), Poster/Document (SC-T Series only), GIS, CAD/Line Drawing, Off (No Color Management)
Select Palette	Software, Default, Palette A, Palette B
Print Color Palette	Prints the color palette pattern.
Define Palette	Palette A, Palette B
Restore default HP-GL/2 Unique Settings	Restores the default HP-GL/2 unique settings.

## Menu List

Item	Setting/Additional Explanation
PS Menu (Except for models without the Adobe PS3 Expansion Unit)	
Version	Displays the PostScript/PDF version.
CMYK Simulation	You can select the CMYK ink color you want to simulate when reproducing CMYK ink colors for an offset printer.
RGB Source	When printing RGB data, you can select the RGB color definition you want to simulate.
Rendering Intent	You can select how to convert the color space when performing absolute colorimetric, relative colorimetric, perceptual, saturation CMYK simulation, and RGM simulation.
Black Point Compensation	On, Off Normally, select <b>On</b> . Select "Off" if you feel shadows are too light when converting from a wide color space to a narrow color space.
Preserve Black	On, Off Set to <b>On</b> to print the K-axis area using black ink when printing CMYK images.
Auto Rotate	On, Off Set to On to automatically rotate print data 90° to the right depending on the paper width, data size, and other conditions.
PS Error Sheet	On, Off Set to <b>On</b> to print the contents of the error when a PostScript error occurs.
Optimize Edge Quality	On, Off Set to <b>On</b> to improve the image quality at the edges.
PDF Rendering Level	Level 1 - 3 Normally, this is set to <b>3</b> . Creates a PS that reproduces the PDF as closely as possible, but may not be printable. If this occurs, try lowering the rendering level.
PDF Overprint Simulation	On, Off Set to <b>On</b> to print the image using transparent colors when printing an image with overprint settings.
Clear All Settings	Restores the PS settings to their default settings.

## Menu List

Item	Setting/Additional Explanation
Reduce Edge Blurriness	On, Off Set to <b>On</b> to reduce edge blurring in image outlines, text, and ruled lines.
Memory Device Interface	Enable, Disable
Thick Paper	On, Off
Bidirectional	On, Off Set to <b>On</b> to make the print head print while moving left and right. Set to <b>Off</b> if ruled lines are misaligned due to print head misalignment.
Print Nozzle Check Pattern during Print	Every Pages, Off Prints a nozzle check pattern for any page. When this is set, a check pattern for clogged nozzles is printed at the top of the page. See the following for details on the nozzle check pattern.  <a href="#">"Print Head Nozzle Check" on page 172</a>
Store Held Job (SC-P6500DE Series/SC-P6500E Series/ SC-T3700DE Series/SC-T3700E Series only)	On, Off Displayed when storage has been set.
Use Production Stacker	Enable, Disable
PC Connection via USB	Enable, Disable
USB I/F Timeout Setting	20 to 600 seconds
Print while Scanning (SC-P8500DM Series/SC-T7700DM Series/ SC-T5700DM Series only)	On, Off You can scan while printing. However, you cannot scan when the optional production stacker is installed.

## Menu List

Item	Setting/Additional Explanation
Network Settings	
Wi-Fi Setup	Allows you to select the Wi-Fi connection method.
Connect via Wi-Fi	<p>Wi-Fi Setup Wizard, Push Button Setup(WPS), Others (PIN Code Setup, Wi-Fi Auto Connect, Disable Wi-Fi)</p> <p>Disable Wi-Fi Allows you to disable Wi-Fi when it is not being used. Since this prevents the printer from emitting signals, the overall power consumption is reduced.</p>
Wi-Fi Direct	iOS, Android, Other OS Devices, Change
Wired LAN Connection Method	Displays the status of the wired LAN connection.
Network Status	

## Menu List

Item	Setting/Additional Explanation
Wired LAN/Wi-Fi Status	Displays the network connection status and IP address.
Wi-Fi Direct Status	Displays the connection name (SSID) and password.
Email Server Status (SC-P8500DM Series/SC-T7700DM Series/SC-T5700DM Series only)	Displays information on the email server settings.
Print Status Sheet	Prints a network status sheet.
Connection Check	Diagnoses the network connection status.
Advanced	
Device Name	Displays the device name.
TCP/IP	Set the IP address of the printer.
Proxy Server	Use, Do Not Use When this is set to Use, you can configure a proxy server.
Email Server (SC-P8500DM Series/SC-T7700DM Series/SC-T5700DM Series only)	You can set up for your email server and test the connection.
Shared Folder	Allows you to make shared folder settings.
IPv6 Address	Enable, Disable Select whether to enable or disable the IPv6 function.
MS Network Sharing	Enable, Disable
Link Speed & Duplex	Auto, 10BASE-T Half Duplex, 10BASE-T Full Duplex, 100BASE-TX Half Duplex, 100BASE-TX Full Duplex
Redirect HTTP to HTTPS	Enable, Disable Set to <b>Enable</b> to automatically convert HTTP to HTTPS for access.
Disable IPsec/IP Filtering	Displays the status of IPsec/IP filtering.
Disable IEEE802.1X	Displays the status of IEEE802.1X.
iBeacon Transmission	Enable, Disable

### Menu List

Item	Setting/Additional Explanation
Scan Settings (SC-P8500DM Series/SC-T7700DM Series/SC-T5700DM Series only)	
Confirm Recipient	Off, On
Document Capture Pro Settings	
Operation Mode	Client Mode, Server Mode
Server Address	You can set the server address.
Group Settings	You can set up for groups.
Email Server	You can set up for your email server.
Scan Options	
Confirm Before Ejecting Scanned Document	On, Off
Correct Skewed Image	On, Off
Document Feed Adjustment	-1.00 - 1.00
Image Stitching Smoother	On, Off
Image Stitching Adjustment	-5 - 5
Auto Remove Background	On, Off

## Menu List

Item	Setting/Additional Explanation
Storage Settings (Displayed when the SSD Unit is connected.)	
Shared Folder Access Control	
Access	Allowed, Not Allowed
Operation Authority	User, Administrator Only
Automatic Delete Setting Authority	User, Administrator Only
Shared Folder File Management	
Automatic File Deletion	Off, On
Period Until Deletion	By Hours, By Days
Apply to All Shared Folders	Applies the automatic deletion setting to all shared folders.
Personal Folder File Management	
Automatic File Deletion	Off, On
Period Until Deletion	By Hours, By Days
Additional Action	
Delete File after Output	Off, On
Access Control	Allowed, Not Allowed
Search Options	Allows you to set the search method for documents in the folder.
Begins with	Searches for documents that begin with a specific phrase.
Ends with	Searches for documents that end with a specific phrase.
Includes	Searches for documents that include a specific phrase.
Access from WebConfig	Allowed, Allowed when Logged in, Not Allowed
System Administration	
Contacts Manager (SC-P8500DM Series/SC-T7700DM Series/SC-T5700DM Series only)	
Register/Delete	You can register or change your contacts.
Frequent	You can manage frequently used contacts.
Print Contacts	List of all Contacts, List of Email Contacts, List of Network Folder/FTP Contacts
View Options	Tile View, List View
Search Options	Begins with, Ends with, Includes



### Menu List

Item	Setting/Additional Explanation
Security Settings	
Restrictions	
Job Log Access	Off, On
Access to Register/Delete Contacts	Off
Access to Recent of Scan to Email	Off, On
Access to Show Sent History of Scan to Email	Off, On
Access to Language	Off, On
Access to Thick Paper	Off, On
Protection of Personal Data	Off, On
Access Control	Off, On
Accept Unknown User Jobs	Off, On
Admin Settings	
Admin Password	Change, Restore Default Settings
Lock Setting	On, Off
Password Encryption	
Password Encryption	Off, On
Encryption Key Backup	Backs up the encryption key.
Audit Log	On, Off
Format the Optional storage unit (Except for the SC-P8500DM Series/ SC-T7700DM Series/SC-T5700DM Series) Format the Storage (SC-P8500DM Series/SC-T7700DM Series/ SC-T5700DM Series only)	Secure (Quick), Secure (Sanitizing) Displayed when the SSD Unit is connected. <input type="checkbox"/> Secure (Quick): Uses a text pattern to randomly overwrite the entire hard disk. <input type="checkbox"/> Secure (Sanitizing): Overwrites and checks 00/FF/random data using an algorithm that complies with the U.S. Department of Defense Standards (DoD5220-22m). This option takes longer than the others to finish formatting, however it does provide the securest method of erasing data. Select this when you need to erase confidential data.
Disable the Optional storage unit (Except for the SC-P8500DM Series/ SC-T7700DM Series/SC-T5700DM Series)	Select this when you need to remove the optional storage.
Restore Default Settings	Network Settings, Copy Settings (SC-P8500DM Series/SC-T7700DM Series/SC-T5700DM Series only), Scan Settings (SC-P8500DM Series/SC-T7700DM Series/SC-T5700DM Series only), Clear All Data and Settings
Firmware Update	Updates to the latest firmware.

## Menu List



# Supply Status

Displays the amount of ink remaining in the ink cartridges or the model number and amount of free space in the maintenance boxes.

 is displayed when the amount of ink remaining in the ink cartridges or the amount of free space in the maintenance boxes is running low. Even if  is displayed, you can continue printing until replacement is required. Prepare new ink cartridges or maintenance boxes as soon as possible.

## Menu List

# Maintenance

Item	Setting/Additional Explanation
Print Head Nozzle Check	Select the paper feed method to print the nozzle check pattern. See the following for details on the nozzle check pattern.  <a href="#">"Print Head Nozzle Check" on page 172</a>
Print Head Cleaning	Cleans the selected color. Only run this when the nozzles are clogged.  <a href="#">"Print Head Cleaning" on page 173</a>
Power Cleaning	Performs power cleaning for the selected color.
Remove Paper	Removes any scraps of paper that remain inside the printer.
Ink Cartridge(s) Replacement	Displays the amount of ink remaining and the model number for the ink cartridge. Press <b>How To...</b> to view the replacement instructions on the screen.
Replace Maintenance Box	Maintenance Box, Borderless Maintenance Box Displays the amount of free space remaining and the model number of the maintenance box. Press <b>How To...</b> to view the replacement instructions on the screen.
Replace Auto cutter blade	You can replace the cutter. Press <b>How To...</b> to view the replacement instructions on the screen.
Adjust Cut Position	-3.0 to 3.0 mm
Cleaning the Maintenance Parts	
Wiping the Print Head	You can clean the print head. Press <b>Start</b> to move the print head to the cleaning position.
Wiping around the Cap	You can clean around the caps. Press <b>Start</b> to move the print head to the cleaning position.
Keeping Preparation	Perform this procedure when the printer is stored or transported in an environment of -10°C or lower. See the following for more information.  <a href="#">"If the Environment Indoors or During Transportation Drops to -10 °C or Lower" on page 236</a>

# Language

You can select the language displayed on the panel. Select from the following languages.

Dutch, English, French, German, Italian, Japanese, Korean, Portuguese, Polish, Russian, Simplified Chinese, Spanish, Traditional Chinese

## Menu List

# Printer Status/Print

Item	Setting/Additional Explanation
Print Status Sheet	Prints a Configuration Status Sheet.
Firmware Version	Displays the Printer, Adobe PS3 Expansion Unit (except for models without the Adobe PS3 Expansion Unit), and the Firmware Version.
Optional storage unit (Except for the SC-P8500DM Series/ SC-T7700DM Series/SC-T5700DM Series) Storage (SC-P8500DM Series/SC-T7700DM Series/ SC-T5700DM Series only)	Displays the connection status of the SSD Unit.
Adobe PS3 Expansion Unit (except for models without the Adobe PS3 Expansion Unit)	Displays the status for the Adobe® PostScript® 3™ Expansion Unit.
Platen Gap Value for Last Print Job	Displays the platen gap value the last time printing was performed.
Network	Displays the connection status for wired, Wi-Fi, and Wi-Fi Direct. You can also print a Status Sheet.
Fatal Error Log	Displays the codes and dates for errors that have occurred in the past.
Operation Report	You can check the operation reports from the total amount of fed media or the total number of carriage passes.
Custom	You can make custom settings for scanning, copying, and printing from folders.  Displayed when settings are available.

# Contacts Manager (SC-P8500DM Series/SC-T7700DM Series/SC-T5700DM Series only)

Item	Setting/Additional Explanation
Register/Delete	You can register, change, or delete your contacts.
Frequent	Email, Network Folder/FTP  Displays addresses that have been set for frequent use. You can also set addresses for standard use.
Print Contacts	List of all Contacts, List of Email Contacts, List of Network Folder/FTP Contacts  You can print your contacts by specifying a print area.
View Options	Tile View, List View  You can change how to view your contacts.
Search Options	Begins with, Ends with, Includes  You can change how to search for contacts.

## Menu List

### User Settings (Except for the SC-P8500DM Series/ SC-T7700DM Series/SC-T5700DM Series)

You can select the paper feed method and so on when printing from the folder.

### User Settings (SC-P8500DM Series/SC-T7700DM Series/SC-T5700DM Series)

Item	Setting/Additional Explanation
Scan to Network Folder/FTP	You can set the Color Mode, File Format, Resolution, and so on as the scan settings.
Scan to Email	You can set the Color Mode, File Format, Resolution, and so on as the scan settings.
Scan to Memory Device	You can set the Color Mode, File Format, Resolution, and so on as the scan settings.
Scan to Storage	You can set the Color Mode, Resolution, Scan Size, and so on as the scan settings.
Copy Settings	You can set the Color Mode, Print Quality, Density, and so on as the copy settings.
Network Folder	You can select the Paper Source, Color Mode, Print Quality and so on when printing from the folder.

### Authentication Device Status

Displays the Authentication Device Status.

### Epson Open Platform Information

Displays the Epson Open Platform version and product key.

### Copy (SC-P8500DM Series/SC-T7700DM Series/ SC-T5700DM Series Only)

Item	Setting/Additional Explanation
Basic Settings	

### Menu List

Item	Setting/Additional Explanation
Copies	Set the number of copies you want to print.
Color Mode	Black/White, Color
Print Quality	Draft, Speed, Fine, High Quality, Max Quality
Density	-4 - 4
Paper Source	Roll(Auto), Roll 1, Roll 2, Cut Sheet, Poster Board
Reduce/Enlarge	You can select the ratio from Auto Fit Page, Custom Size, Actual Size, or Specified Size.
Page Margins option	Clip By Margins, Oversize, Borderless
<b>Advanced</b>	
Original Type	Text/Line Drawing & Image, Tracing Paper, Blueprint, Blueprint Inverted, Watercolor Rendering
<b>Original Size</b>	
Regular Size	Select Auto Detect or a default original size.
User-Defined	Enter manually, User-Defined List
Top Offset	Sets the alignment position for the top edge.
Image Quality	Contrast, Color Correction, Sharpness, Remove Background
Bidirectional	On, Off
Auto Rotate	On, Off
File Storing	You can save copied data to a storage space.
Clear All Settings	You can clear the copy settings.

## Scan (SC-P8500DM Series/SC-T7700DM Series/SC-T5700DM Series Only)

Item	Setting/Additional Explanation
Network Folder/FTP	

### Menu List

Item	Setting/Additional Explanation
Destination	You can set the communication mode, storage location, and so on.
Scan Settings	
Color Mode	Black/White, Color
File format	You can set the File Format, Compression Ratio, and PDF Settings.
Resolution	200dpi, 300dpi, 400dpi, 600dpi
Scan Size	Select the scan size of the original
Top Offset	Sets the alignment position for the top edge.
Original Type	Text/Line Drawing & Image, Tracing Paper, Blueprint, Blueprint Inverted, Watercolor Rendering
Density	-4 - 4
Image Quality	Contrast, Sharpness, Remove Background
File Storing	You can save scanned data to a storage space.
File Name	You can set a file name for the scanned data.
Email	
Destination	You can set the destination.
Scan Settings	
Color Mode	Black/White, Color
File format	You can set the File Format, Compression Ratio, and PDF Settings.
Resolution	200dpi, 300dpi, 400dpi, 600dpi
Scan Size	Select the scan size of the original
Top Offset	Scan to align with the top edge.
Original Type	Text/Line Drawing & Image, Tracing Paper, Blueprint, Blueprint Inverted, Watercolor Rendering
Density	-4 - 4
Image Quality	Contrast, Sharpness, Remove Background
File Storing	You can save scanned data to a storage space.
Subject	You can set the subject line of the email.
Attached File Max Size	1MB, 2MB, 5MB, 10MB, 20MB, 30MB
File Name	You can set a file name for the scanned data.
Mail Encryption	On, Off
Digital Signature	On, Off
Menu	Show Sent History, Email Server

## Menu List

Item	Setting/Additional Explanation
Computer	You can save scanned data to a specified computer.
Memory Device	
Basic Settings	
Color Mode	Black/White, Color
File format	You can set the File Format, Compression Ratio, and PDF Settings.
Resolution	200dpi, 300dpi, 400dpi, 600dpi
Scan Size	Select the scan size of the original
Top Offset	Scan to align with the top edge.
Original Type	Text/Line Drawing & Image, Tracing Paper, Blueprint, Blueprint Inverted, Watercolor Rendering
Advanced	
Density	-4 - 4
Image Quality	Contrast, Sharpness, Remove Background
File Storing	You can save scanned data to a storage space.
File Name	You can set a file name for the scanned data.
Storage	
Store to	You can set the location.
Scan Settings	
Color Mode	Black/White, Color
Resolution	200dpi, 300dpi, 400dpi, 600dpi
Scan Size	Select the scan size of the original
Top Offset	Scan to align with the top edge.
Original Type	Text/Line Drawing & Image, Tracing Paper, Blueprint, Blueprint Inverted, Watercolor Rendering
Density	-4 - 4
Image Quality	Contrast, Sharpness, Remove Background
File Name	You can set a file name for the scanned data.
File Password	You can set a password for the scanned data.
User Name	You can set the user name of the user who created the scanned data.
WSD (except when set to Japanese)	WSD (Web Service for Devices) for Windows OS can automatically detect devices on the network.

## Menu List

## Memory Device

Item	Setting/Additional Explanation
JPEG	
Display order	You can set the display order.
Basic Settings	
Paper Source	Roll(Auto), Roll 1, Roll 2, Cut Sheet, Poster Board
Color Mode	Black/White, Color
Advanced	
Print Quality	Draft, Speed, Fine, High Quality, Max Quality
Page Margins option	Clip By Margins, Oversize, Borderless
Bidirectional	On, Off
Select Target	Poster(Photo)/Perspective (SC-P Series only), Poster/Document (SC-T Series only), GIS, CAD/Line Drawing, Off (No Color Management)
CMYK Simulation	You can select the CMYK ink color you want to simulate when reproducing CMYK ink colors for an offset printer. Displayed when the Adobe PS3 expansion unit is enabled.
RGB Source	When printing RGB data, you can select the RGB color definition you want to simulate. Displayed when the Adobe PS3 expansion unit is enabled.
Rendering Intent	You can select how to convert the color space when performing absolute colorimetric, relative colorimetric, perceptual, saturation CMYK simulation, and RGM simulation. Displayed when the Adobe PS3 Expansion Unit is enabled.
Target Contents	Standard, GIS, Line Drawing Displayed when the Adobe PS3 Expansion Unit is enabled.
Reduce/Enlarge	You can select the ratio from Auto Fit Page, Custom Size, Actual Size, or Specified Size.
File Storing	You can set the storage space in which to save data printed from a memory device. This is available when the optional SSD Unit is connected.
PDF (Displayed when the Adobe PS3 Expansion Unit is enabled.)	
Epson Scanned PDF (Displayed when the Adobe PS3 Expansion Unit is enabled.)	

## Menu List

Item	Setting/Additional Explanation
Display order	You can set the display order.
Basic Settings	
Paper Source	Roll(Auto), Roll 1, Roll 2, Cut Sheet, Poster Board
Color Mode	Black/White, Color
Advanced	
Print Quality	Draft, Speed, Fine, High Quality, Max Quality
Page Margins option	Clip By Margins, Oversize, Borderless
Bidirectional	On, Off
Select Target	Poster(Photo)/Perspective (SC-P Series only), Poster/Document (SC-T Series only), GIS, CAD/Line Drawing, Off (No Color Management)
CMYK Simulation	You can select the CMYK ink color you want to simulate when reproducing CMYK ink colors for an offset printer. Displayed when the Adobe PS3 expansion unit is enabled.
RGB Source	When printing RGB data, you can select the RGB color definition you want to simulate. Displayed when the Adobe PS3 expansion unit is enabled.
Rendering Intent	You can select how to convert the color space when performing absolute colorimetric, relative colorimetric, perceptual, saturation CMYK simulation, and RGM simulation. Displayed when the Adobe PS3 Expansion Unit is enabled.
Target Contents	Standard, GIS, Line Drawing Displayed when the Adobe PS3 Expansion Unit is enabled.
Reduce/Enlarge	You can select the ratio from Auto Fit Page, Custom Size, Actual Size, or Specified Size.
File Storing	You can set the storage space in which to save data printed from a memory device. This is available when the optional SSD Unit is connected.
TIFF	

## Menu List

Item	Setting/Additional Explanation
Display order	You can set the display order.
Basic Settings	
Paper Source	Roll(Auto), Roll 1, Roll 2, Cut Sheet, Poster Board
Color Mode	Black/White, Color
Advanced	
Print Quality	Draft, Speed, Fine, High Quality, Max Quality
Page Margins option	Clip By Margins, Oversize, Borderless
Bidirectional	On, Off
Select Target	Poster(Photo)/Perspective (SC-P Series only), Poster/Document (SC-T Series only), GIS, CAD/Line Drawing, Off (No Color Management)
CMYK Simulation	You can select the CMYK ink color you want to simulate when reproducing CMYK ink colors for an offset printer. Displayed when the Adobe PS3 Expansion Unit is enabled.
RGB Source	When printing RGB data, you can select the RGB color definition you want to simulate. Displayed when the Adobe PS3 Expansion Unit is enabled.
Rendering Intent	You can select how to convert the color space when performing absolute colorimetric, relative colorimetric, perceptual, saturation CMYK simulation, and RGM simulation. Displayed when the Adobe PS3 Expansion Unit is enabled.
Target Contents	Standard, GIS, Line Drawing Displayed when the Adobe PS3 Expansion Unit is enabled.
Reduce/Enlarge	You can select the ratio from Auto Fit Page, Custom Size, or Specified Size.
File Storing	You can set the storage space in which to save data printed from a memory device. This is available when the optional SSD Unit is connected.
HP-GL/2	

## Menu List

Item	Setting/Additional Explanation
Display order	You can set the display order.
Basic Settings	
Paper Source	Roll(Auto), Roll 1, Roll 2, Cut Sheet, Poster Board
Color Mode	Black/White, Color
Advanced	
Print Quality	Draft, Speed, Fine, High Quality, Max Quality
Page Margins option	Clip By Margins, Oversize
Bidirectional	On, Off
Select Target	Poster(Photo)/Perspective (SC-P Series only), Poster/Document (SC-T Series only), GIS, CAD/Line Drawing, Off (No Color Management)
Base Output Size	Auto, A Series, US-ANSI, US-ARCH, B Series (ISO), B Series (JIS), Photo Series, Others, User Defined
File Storing	You can set the storage space in which to save data printed from a memory device.

## Network Folder

Item	Setting/Additional Explanation
Basic Settings	
Paper Source	Roll(Auto), Roll 1, Roll 2, Cut Sheet, Poster Board
Color Mode	Black/White, Color
Advanced	
Common Settings	
Print Quality	Draft, Speed, Fine, High Quality, Max Quality
Bidirectional	On, Off
File Storing	You can save data printed from a folder to a storage space.
HP-GL/2 Unique Settings	
Page Margins option	Clip By Margins, Oversize
Select Target	Poster(Photo)/Perspective (SC-P Series only), Poster/Document (SC-T Series only), GIS, CAD/Line Drawing, Off (No Color Management)
Base Output Size	Auto, A Series, US-ANSI, US-ARCH, B Series (ISO), B Series (JIS), Photo Series, Others, User Defined

## Menu List

Item	Setting/Additional Explanation
Except for HP-GL/2	
Page Margins option	Clip By Margins, Oversize, Borderless
Select Target	Poster(Photo)/Perspective (SC-P Series only), Poster/Document (SC-T Series only), GIS, CAD/Line Drawing, Off (No Color Management)
CMYK Simulation	You can select the CMYK ink color you want to simulate when reproducing CMYK ink colors for an offset printer.
RGB Source	When printing RGB data, you can select the RGB color definition you want to simulate.
Rendering Intent	You can select how to convert the color space when performing absolute colorimetric, relative colorimetric, perceptual, saturation CMYK simulation, and RGM simulation.
Target Contents	Standard, GIS, Line Drawing
Reduce/Enlarge	You can select the ratio from Auto Fit Page, Custom Size, or Regular Size.

## Storage (Only when an SSD Unit is Installed)

Item	Setting/Additional Explanation
Open	
Delete	Delete data in the storage space.
Delete All	Delete all data in the storage space.
Others	File Name, User Name, File Password
Store (SC-P8500DM Series/SC-T7700DM Series/SC-T5700DM Series only)	
Settings	
Folder Number	You can divide storage spaces by number.
Folder Name (Required)	You can name the storage spaces.
Folder Password	Register, Change, Clear All Settings
Automatic File Delete Settings	
Automatic File Deletion	Follow General Settings, Off, On
Period Until Deletion	By Hours, By Days
Delete	

## Maintenance

# Maintenance

## Print Head Maintenance

You need to perform print head maintenance if white lines appear in your print outs or if you notice the print quality has declined.

## Maintenance Operations

You can perform the following printer maintenance functions for maintaining the print head in good condition to ensure the best print quality. Carry out appropriate maintenance depending on the print results and situation.

### Auto Cleaning

When this is set to On, the printer automatically checks for clogged nozzles and performs cleaning if it detects clogged nozzles.

**Note:**

- This function does not guarantee 100% detection of clogged nozzles.
- A small amount of ink is consumed when detecting clogged nozzles.
- Ink is consumed when performing automatic cleaning.

You can change the timing for the nozzle check in Auto Cleaning. Set this to Off if you do not want to perform auto cleaning.

 [“General Settings” on page 147](#)

**Note:**

*Even when Auto Cleaning is set to Off, auto cleaning may be performed to maintain printer quality.*

### Print Head Nozzle Check

Print a nozzle check pattern to check for clogged nozzles if you have not used the printer for an extended period or before printing an important job. Visually inspect the printed check pattern and clean the print head if you notice faint or missing areas.

 [“Print Head Nozzle Check” on page 172](#)

### Print Head Cleaning

Use this if you notice faint or missing areas in the prints. Cleans the surface of the print head to improve the print quality. There are two types of cleaning available depending on the level of cleaning required; normal head cleaning and powerful head cleaning.

 [“Print Head Cleaning” on page 173](#)

Normally, perform Normal head cleaning. If nozzles are clogged even after performing Normal head cleaning several times, perform Powerful Cleaning.

### Paper Feed Adjust

Use this function if you are unable to resolve banding issues (horizontal striped lines or uneven colors) in the standard print area (for cut sheets, the area excluding the 1 to 2 cm strip at the bottom of the paper) even after cleaning the print head or performing head alignment.

 [“Paper Feed Adjust” on page 175](#)

### Ruled Line Alignment

Adjust the position of the print head when lines are misaligned or when the print results appear grainy. Print Head Alignment corrects print head misalignments during printing.

 [“Ruled Line Alignment” on page 176](#)

## Print Head Nozzle Check

Nozzle checks can be performing from a computer or using printer's control panel.

### From the printer

- 1** Make sure that the roll paper or a cut sheet of A4 size or larger is loaded in the printer.
- 2** Choose a paper type that matches the paper in the printer.
 

 [“Setting Loaded Paper” on page 56](#)
- 3** Press **Menu - Maintenance - Print Head Nozzle Check**.

## Maintenance

**4** Press **Start** to start printing a check pattern.

**5** Review the printed check pattern while referring to the following section.

### Example of clean nozzles

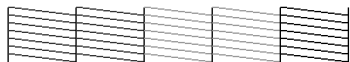

If none of the pattern is missing, the print head nozzles are not clogged. Press  to end the nozzle clogging check.

### Example of clogged nozzles

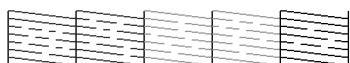

If any segments are missing in the nozzle check pattern, press  to perform head cleaning.

**6** Select the row of nozzles you want to clean, and then press **OK**.

Cleaning starts. Cleaning takes about 4 to 9 minutes.

#### Note:

*The more color pairs selected, the longer it takes to perform cleaning. Also, depending on the status of the nozzles, it can take up to about 32 minutes.*

**7** Follow the on-screen instructions to print a check pattern, and inspect the results to determine if the problem has been resolved.

## From the computer

Explanations in this section use the Windows printer driver as an example.

Use Epson Printer Utility 4 for Mac.

 [“Epson Printer Utility 4 Functions” on page 127](#)

**1** Make sure that the roll paper or a cut sheet of A4 size or larger is loaded in the printer.

**2** Choose a paper type that matches the paper in the printer.

 [“Setting Loaded Paper” on page 56](#)

**3** Click **Print Head Nozzle Check** from the **Utility** tab in the printer driver's **Properties** (or **Printing preferences**) screen.

**4** Click **Print**.

The nozzle check pattern is printed.

**5** Check the nozzle check pattern.

If there is no problem: click **Finish**.

If there is a problem: click **Clean**.

After printing a nozzle check pattern, make sure that the nozzle check pattern printing is complete before printing your data or cleaning the print head.

## Print Head Cleaning

Although head cleaning can be performed from the computer or the printer, the cleaning procedures differ as explained below.

### From the printer

You can select two levels of cleaning strength.

 [“From the printer” on page 174](#)

### From the computer

 [“From the computer” on page 174](#)

## Notes on Print Head Cleaning

### Ink is consumed during head cleaning.

Clean the print head only if print quality declines; for example, if the printout is blurry or the color is incorrect or missing.

### When cleaning all nozzles, ink is consumed from all colors.

Even if you are using only black inks for black and white printing, color inks are also consumed.

### Prepare a new maintenance box if there is not enough empty space in the box.

If you repeat head cleaning, the ink in the maintenance box may fill up sooner than expected.

## Maintenance

### Power Cleaning consumes much more ink than Print Head Cleaning.

Check the remaining ink level in advance, and prepare a new ink cartridge before you start cleaning if the ink is low.

**Print head cleaning cannot be performed unless the temperature conditions are correct. See the following for the appropriate temperature conditions.**

 [“Specifications Table \(Except for the SC-P8500DL Series/SC-T7700DL Series\)” on page 240](#)

 [“Specifications Table \(SC-P8500DL Series/SC-T7700DL Series Only\)” on page 243](#)

**If the nozzles are still clogged after performing Power Cleaning, turn off the printer and leave it overnight or longer.**

When left for some time, the clogged ink may dissolve.

If the nozzles are still clogged, contact your dealer or Epson Support.

### From the printer

Before starting this procedure, be sure to read the following:

 [“Notes on Print Head Cleaning” on page 173](#)

- 1** Select **Menu - Maintenance - Print Head Cleaning** on the control panel.
- 2** Select nozzle arrays for cleaning.  
Select the color pairs with faint or missing segments in the check pattern.
- 3** Press **OK** to start cleaning.  
Head cleaning takes about 4 to 10 minutes.

**Note:**

*The more color pairs selected, the longer it takes to perform cleaning. Depending on the status of the nozzles and the Auto Clean Max Repeat setting, this function can take up to 28 minutes.*

A confirmation message is displayed when cleaning is complete.

- 4** Press **Yes** to print a check pattern and check for clogging.

If you do not want to perform a nozzle check, press **No** to exit.

If the nozzles are still clogged, repeat steps 1 to 3 several times. If you cannot clear the clogged nozzles even after repeating cleaning several times, see the following to perform **Power Cleaning**.

### Power Cleaning

Before starting this procedure, be sure to read the following:

 [“Notes on Print Head Cleaning” on page 173](#)

- 1** Select **Menu - Maintenance - Power Cleaning** on the control panel.
- 2** Select the nozzle arrays for Power Cleaning.  
Select the color pairs with faint or missing segments in the check pattern.
- 3** Press the **OK** button to start Power Cleaning.  
Power Cleaning takes about 8 minutes.

**Note:**

*The more color pairs selected, the longer it takes to perform cleaning. Also, depending on the status of the nozzles, it can take up to about 28 minutes.*

When Power Cleaning is complete, you are returned to the screen displayed before cleaning was performed.

- 4** Press **Yes** to print a check pattern and check for clogging.  
If you do not want to perform a nozzle check, press **No** to exit.

### From the computer

Before starting this procedure, be sure to read the following:

 [“Notes on Print Head Cleaning” on page 173](#)

## Maintenance

Explanations in this section use the Windows printer driver as an example.

Use Epson Printer Utility 4 for Mac.

 [“Using Epson Printer Utility 4” on page 127](#)

**1** Click **Print Head Cleaning** from the **Utility** tab in the printer driver's **Properties** (or **Printing preferences**) screen.

Select **All Colors** to clean all of the print heads (nozzles).

When you select **Auto Select**, a nozzle check is performed and only the clogged print heads (nozzles) are cleaned. Cleaning is not performed if the print heads (nozzles) are not clogged.

**2** Click **Start**.

Head cleaning starts. Head cleaning takes about 4 to 9 minutes.

**Note:**

*When **Auto Cleaning** is set to On, the nozzles are checked after head cleaning, and if clogging is detected, auto cleaning is performed. Depending on the status of the nozzles and the Auto Clean Max Repeat setting, this function can take up to 32 minutes.*

**3** Click **Print Head Nozzle Check**.

Check the nozzle check pattern.

If you see any faint or missing segments in the nozzle check pattern, click **Clean**.

If you cannot clear the clogged nozzles even after repeating cleaning several times in succession, select **Power Cleaning** from **Print Head Cleaning** on the printer's control panel.

 [“From the printer” on page 174](#)

## Paper Feed Adjust

Use this function if you are unable to resolve banding issues (horizontal striped lines or uneven colors) in the standard print area (for cut sheets, the area excluding the 1 to 2 cm strip at the bottom of the paper) even after cleaning the print head or performing head alignment.

The following types of paper feed adjustment are available. However, you may not be able to select some items depending on the paper.

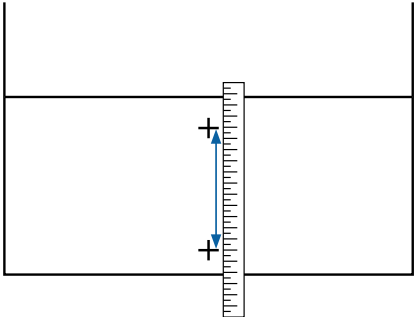
Auto	We normally recommend using this method as it rarely causes any problems and is easy to execute. It takes about 9 to 35 minutes to complete the adjustments. The time required varies depending on the status of the printer.
Manual	<p>Select the following if you are not satisfied with the adjustments made by <b>Auto</b>, or if you want to perform <b>Paper Feed Adjust</b> to match your printing needs.</p> <p>Select <b>Quality First</b> or <b>Length Accuracy First</b> as the adjustment method.</p> <p><b>Quality First</b> is suitable for printing images that require an emphasis on image quality. Make adjustments while visually checking the adjustment patterns.</p> <p><b>Length Accuracy First</b> is suitable for printing images that require an emphasis on dimensions and length such as CAD. Measure and adjust the distance of the printed measurement positions. Prepare a long ruler that can measure in increments of 0.5 mm.</p> 

## Paper feed adjustment method

**1** Load the paper.

Load paper that is 388 mm or wider and 558 mm or longer. When adjusting using commercially available paper, make sure you register the Custom Paper in advance.

**2** Choose a paper type that matches the paper in the printer.

 [“Setting Loaded Paper” on page 56](#)

**3** Select **Menu - Paper Setting - Print Adjustments - Paper Feed Adjust** from the control panel.

## Maintenance

**4** Select the paper feed adjustment that best suits your needs and intended usage.

**5** If you select manual adjustment, follow the on-screen instructions to make adjustments.

### Ruled Line Alignment

If lines are misaligned or print results are grainy, perform Print Head Alignment.

The print head fires ink when moving to the left and to the right while printing. Since there is a short distance (gap) between the paper surface and the print head, a print misalignment may occur due to the paper thickness, changes in temperature or humidity, and internal inertia while the print head moves.

The following types of ruled line alignment are available. However, you may not be able to select some items depending on the paper.

Auto(Standard)	We normally recommend using this method as it rarely causes any problems and is easy to execute. It takes about 9 to 35 minutes to complete the adjustments. The time required varies depending on the status of the printer.
Auto(Details)	Use this menu if you are not satisfied with the results of adjustment performed by <b>Auto(Standard)</b> or when ruled lines are misaligned at the edge of the paper. It takes about 9 to 35 minutes to complete the adjustments. The time required varies depending on the status of the printer.
Manual(Standard)	Use this menu if you are not satisfied with the results of adjustment performed by <b>Auto</b> . Make adjustments while visually checking the adjustment patterns.
Manual(Details)	Use this menu if you are not satisfied with the adjustments made by <b>Auto</b> or <b>Manual(Standard)</b> , or if you want to perform <b>Ruled Line Alignment</b> to match your printing needs. Select the items that suit your printing needs in <b>Select Target</b> and <b>Print Quality</b> , and the pattern is printed. Make adjustments while visually checking the adjustment patterns.

### Precautions when performing Ruled Line Alignment

**Adjustments are made depending on the paper loaded in the printer.**

Choose a paper type that matches the paper in the printer.  
When adjusting using commercially available paper, make sure you register the custom paper in advance.

 [“Setting Loaded Paper” on page 56](#)

**Make sure that nozzles are not clogged.**

If nozzles are clogged, adjustment may not be performed correctly. Print the check pattern, perform a visual inspection, and perform head cleaning if necessary.

 [“Print Head Nozzle Check” on page 172](#)

**Auto adjustment cannot be performed when using the following paper.**

- Plain Paper
- Enhanced Matte Board
- Transparent or colored paper

Perform manual adjustment when using these types of paper.

**When performing auto adjustment, make sure that no external light (direct sunlight) enters the printer.**

Otherwise, the printer's sensors may not read the adjustment pattern correctly. If auto adjustment cannot be performed even after making sure no external light is entering the printer, perform manual adjustment.

### Ruled Line Alignment method

Before starting this procedure, be sure to read the following:

 [“Precautions when performing Ruled Line Alignment” on page 176](#)

## Maintenance

- 1 Load the paper.  
When performing Auto(Standard) or Auto(Details), load paper that is 388 mm or wider and 558 mm or longer.  
When performing Manual(Standard) or Manual(Details), load paper that is 210 mm or wider and 297 mm or longer.  
When adjusting using commercially available paper, make sure you register the Custom Paper in advance.
- 2 Choose a paper type that matches the paper in the printer.  
 [“Setting Loaded Paper” on page 56](#)
- 3 Select **Menu - Paper Setting - Print Adjustments - Ruled Line Alignment** from the control panel.
- 4 Select the ruled line alignment that best suits your needs and intended usage.
- 5 If you select manual adjustment, follow the on-screen instructions to make adjustments.

## Replacing Consumables

### Replacing Ink Cartridges (Except for the SC-P8500DL Series/SC-T7700DL Series)

If one of the installed ink supply units is expended, printing cannot be performed.

If an ink cartridge remaining amount falls below the minimum amount, you can continue printing after replacing the ink cartridge.

If the remaining ink amount drops yet printing is continued, then replacement of an ink cartridge during printing may be required. If you replace it while printing, colors may look different depending on how the ink dries. When this is not permissible, we recommend first replacing the ink cartridge with a new one before printing. The removed ink cartridge can be installed again and used until the remaining amount falls below the minimum amount.

Supported ink cartridges  [“Options and Consumable Products” on page 214](#)

### Replacing Ink Cartridges

You can use the same procedure to replace all ink cartridges.

#### **Important:**

*Epson recommends the use of genuine Epson ink cartridges. Epson cannot guarantee the quality or reliability of non-genuine ink. The use of non-genuine ink may cause damage that is not covered by Epson's warranties, and under certain circumstances, may cause erratic printer behavior. Information about non-genuine ink levels may not be displayed, and use of non-genuine ink is recorded for possible use in service support.*

## Maintenance

- 1** Remove the new ink cartridge from the bag.

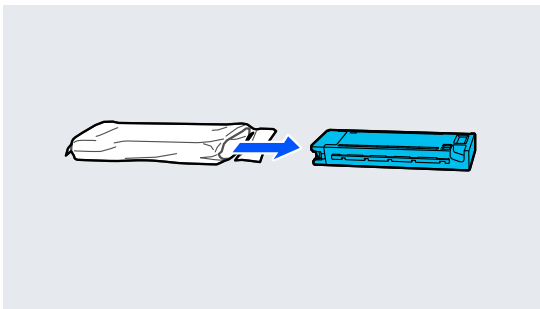

**!** **Important:**

Do not touch the parts shown in the illustration.

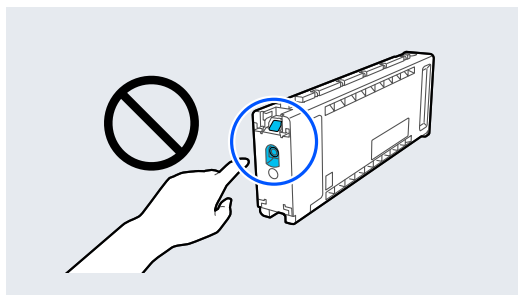

- 2** Shake the ink cartridge for 10 seconds 30 times horizontally in approximately 10 cm movements as shown in the illustration.

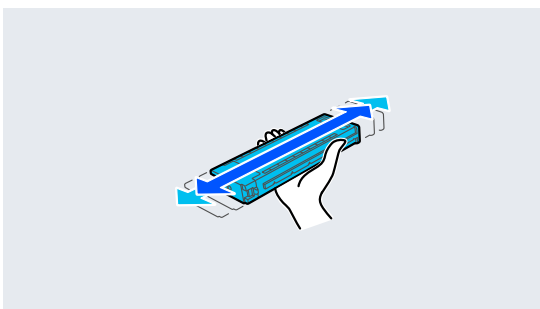

- 3** Open the ink cartridge cover.

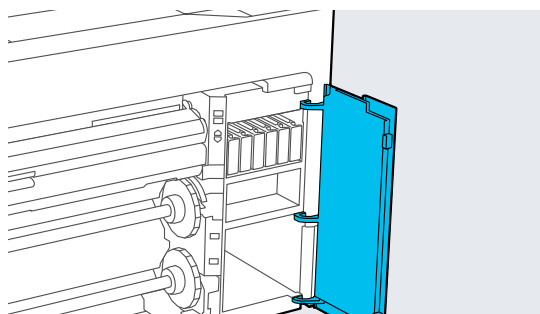
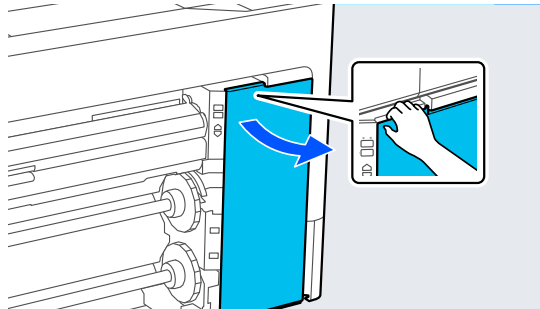

- 4** Place your finger into the gap and remove the ink cartridge.

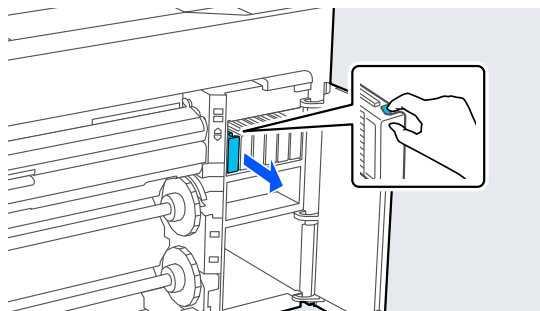

**!** **Important:**

Removed ink cartridges may have ink around the ink supply port, so be careful not to get any ink on the surrounding area when removing the cartridges.

- 5** Push the ink cartridge all the way into the slot.

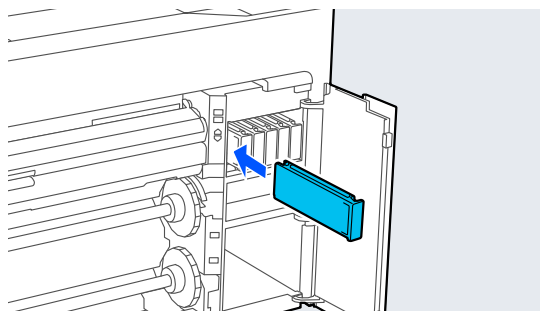

## Maintenance

**! Important:**

Install ink cartridges into all slots. You cannot print if any of the slots are empty.

- 6** Close the ink cartridge cover.

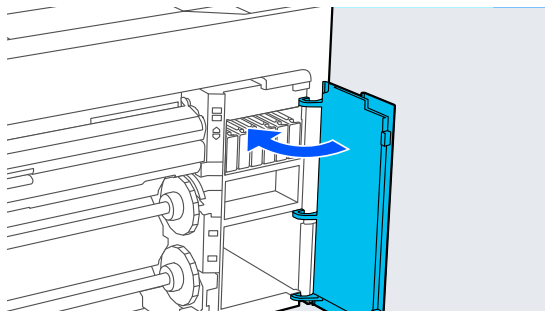

### Replacing Ink Supply Units (SC-P8500DL Series/ SC-T7700DL Series Only)

If one of the installed ink supply units is expended, printing cannot be performed. If ink is expended while printing, you can continue printing after replacing the ink supply unit. If you continue to use an ink supply unit that is running low, you may need to replace the ink supply unit while printing. If you replace it while printing, colors may look different depending on how the ink dries. If you want to avoid issues such as this, we recommend replacing the ink supply unit before printing. You can still use the removed ink supply unit in the future until it is expended.

Supported ink supply units

[“Ink Supply Units \(SC-P8500DL Series/SC-T7700DL Series\)”](#) on page 217

**! Important:**

Epson recommends the use of genuine Epson ink supply units. Epson cannot guarantee the quality or reliability of non-genuine ink. The use of non-genuine ink may cause damage that is not covered by Epson's warranties, and under certain circumstances, may cause erratic printer behavior. Information about non-genuine ink levels may not be displayed, and use of non-genuine ink is recorded for possible use in service support.

- 1** Move the lock switch as shown in the illustration to unlock it, and then remove the ink tray with both hands.

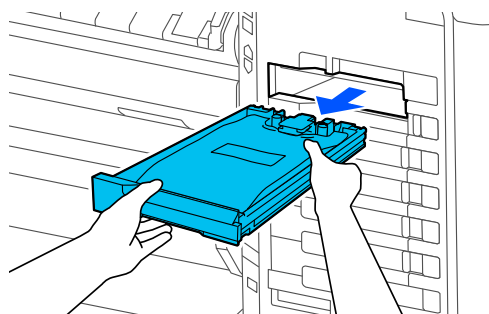
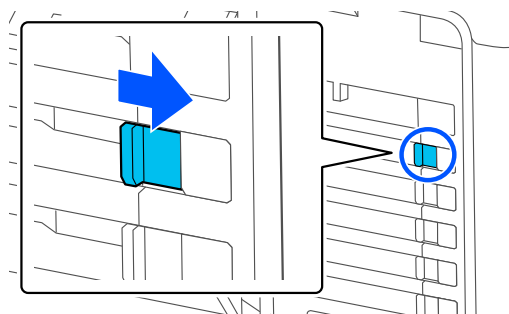

**! Important:**

Removed ink supply units may have ink around the ink supply port, so be careful not to get any ink on the surrounding area when removing the ink supply units.

- 2** Pull out the ink supply unit.

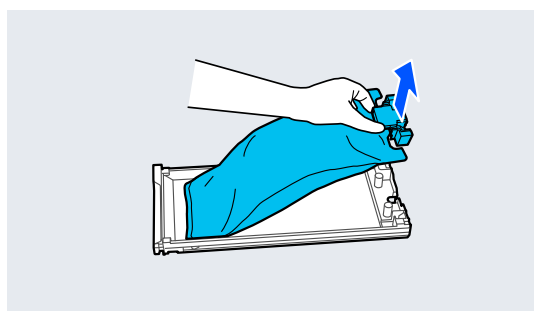

## Maintenance

- 3** Do not touch the parts shown in the illustration.

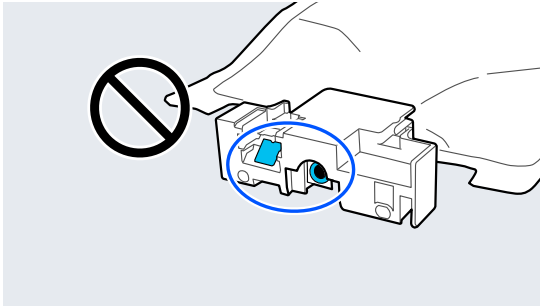

- 4** Place the ink supply unit into the tray.

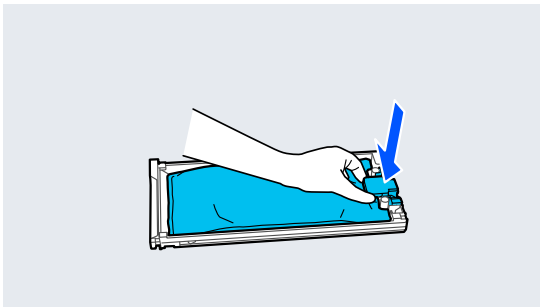
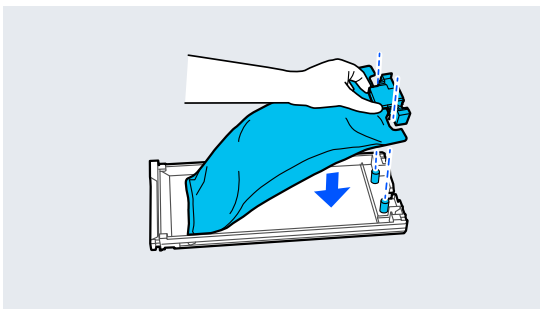

- 5** Hold the tray and shake it up and down at an angle of approximately 60 degrees, as shown in the illustration, approximately 10 times in 10 seconds.

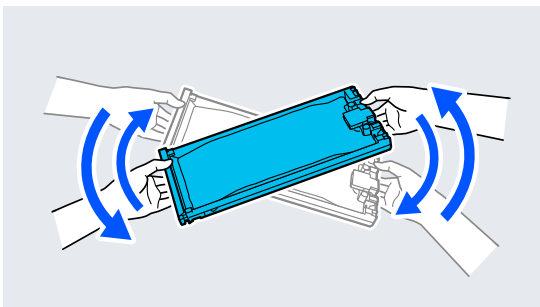

- 6** Check the color and then insert the ink tray; push the ink tray firmly all the way in.

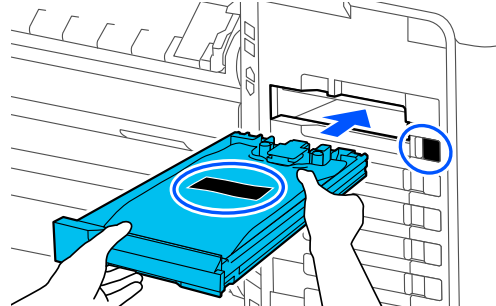

**!** **Important:**

*Install ink trays in all of the slots. You cannot print if any of the slots are empty.*

- 7** Move the lock switch as shown in the illustration to lock it.

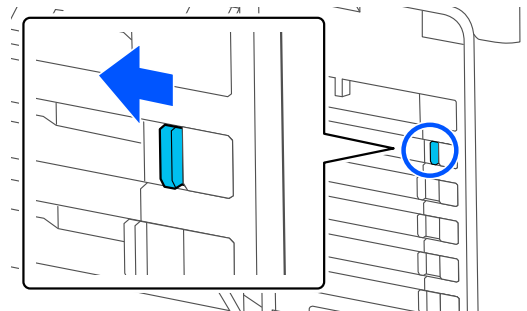

## Replacing the Maintenance Box and Borderless Maintenance Box

Replace the maintenance box with the Not Enough Space message displayed.

Supported Maintenance Box

 [“Options and Consumable Products” on page 214](#)

**!** **Important:**

*Do not reuse maintenance boxes that have been removed and left out in the open for a long period of time. The ink on the inside will be dry and hard and will be unable to absorb enough ink.*

## Maintenance

### Replacing the Maintenance Box

**!** **Important:**

*Do not replace the Maintenance Box while printing.  
Failure to observe this precaution could cause ink to leak.*

- 1** Prepare a new Maintenance Box and the clear bag included.

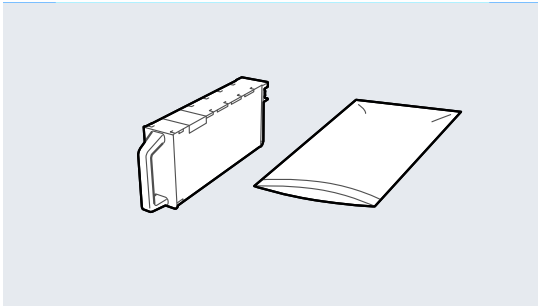

**!** **Important:**

*Do not touch the IC chip on the maintenance box.  
Doing so may prevent normal operation and printing.*

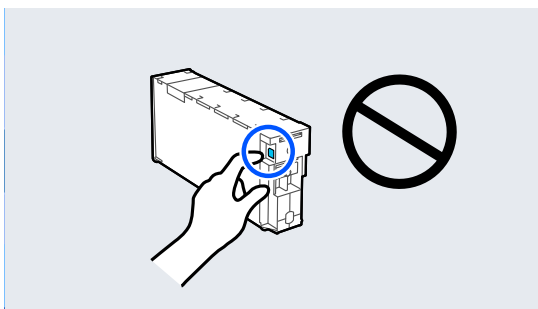

- 2** Open the maintenance box cover.

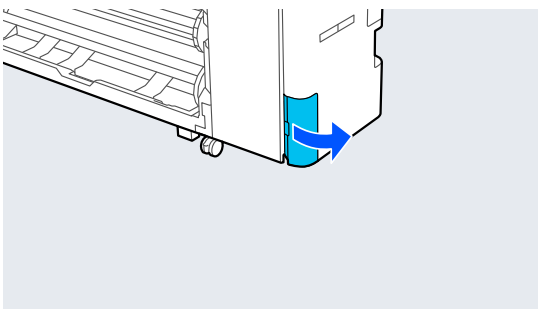

- 3** Pull out the Maintenance Box.

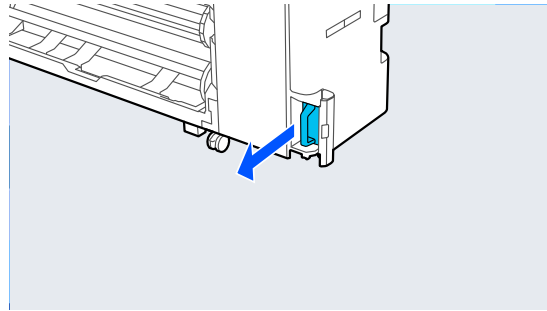

- 4** Place the used Maintenance Box in the clear bag included.

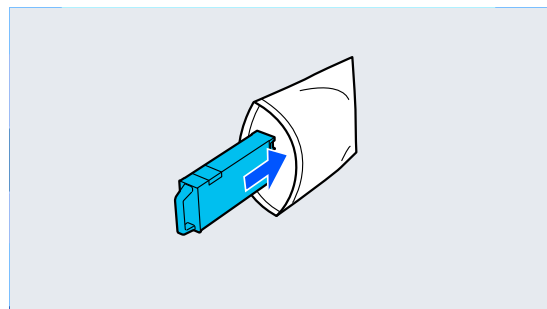

**!** **Important:**

*Do not tilt the Maintenance Box until the bag's press seal has been firmly closed. Failure to observe this precaution could cause ink to leak.*

- 5** Carefully insert the new Maintenance Box.

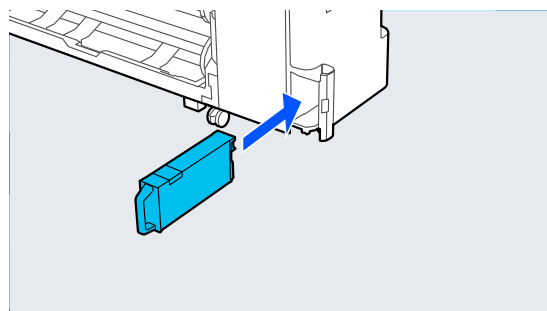

## Maintenance

- 6** Close the maintenance box cover.

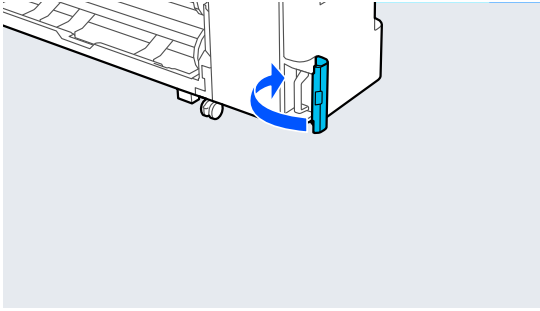

### Replacing the Borderless Maintenance Box

Follow the steps below to replace the Borderless Maintenance Box (maintenance box for borderless printing).

**!** **Important:**

*Do not replace the Borderless Maintenance Box while printing.  
Failure to observe this precaution could cause ink to leak.*

- 1** Prepare a new Borderless Maintenance Box and the clear bag included.

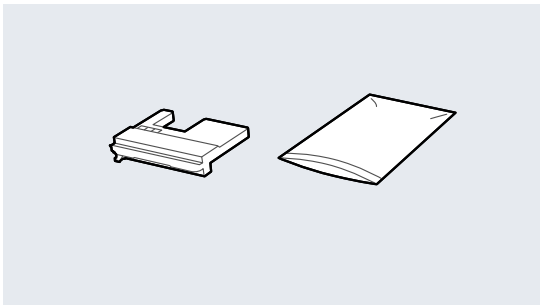

**!** **Important:**

*Do not touch the IC chip on the Borderless Maintenance Box.  
Doing so may prevent normal operation and printing.*

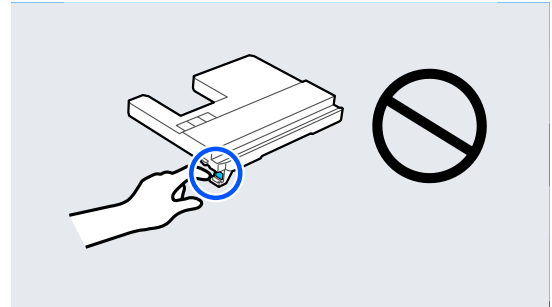

- 2** Set the paper support to the position shown in the illustration, and then open the flap.

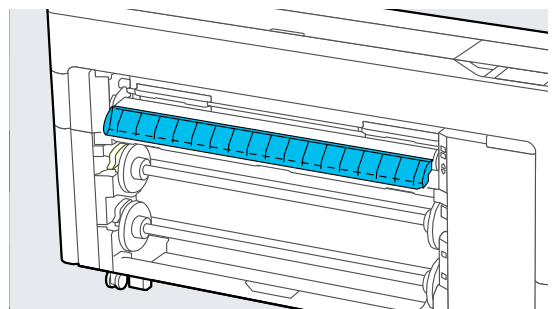
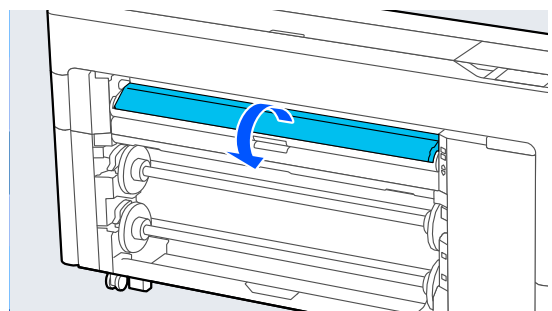
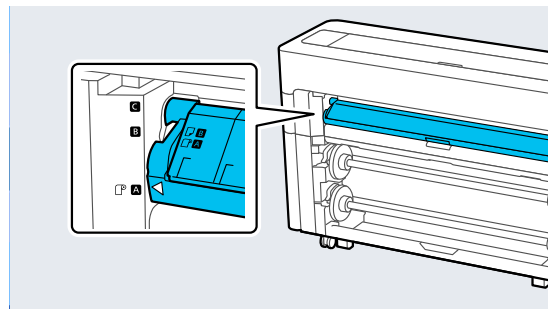
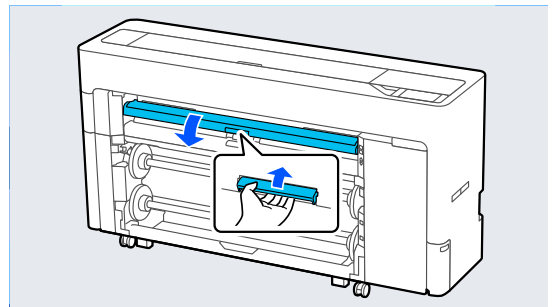

## Maintenance

- 3** Set the paper support to the position shown in the illustration.

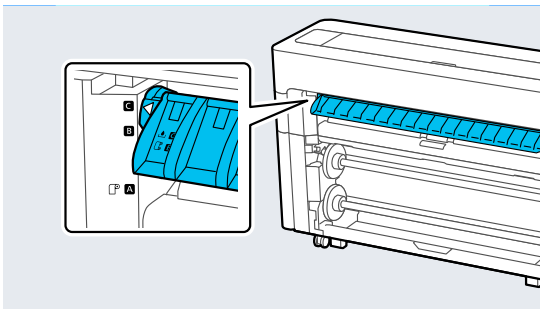
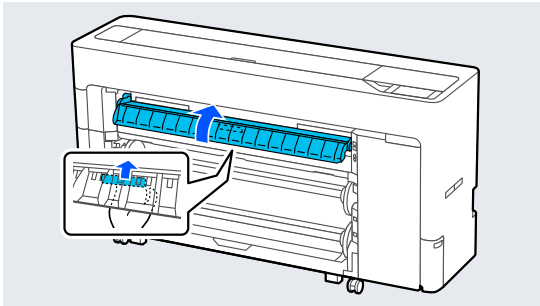

- 4** Pull out the Borderless Maintenance Box.

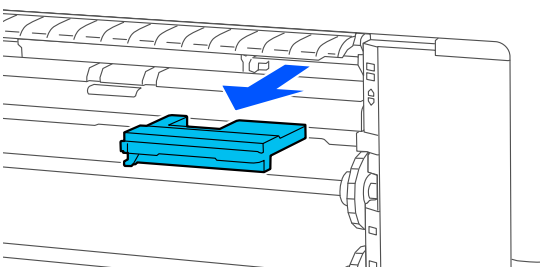
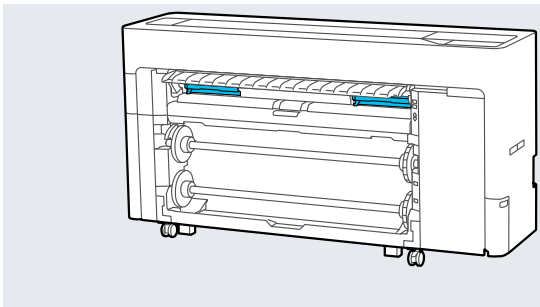

**Note:**

The location of the Borderless Maintenance Box varies slightly depending on the model.

- 5** Place the used Borderless Maintenance Box in the clear bag included.

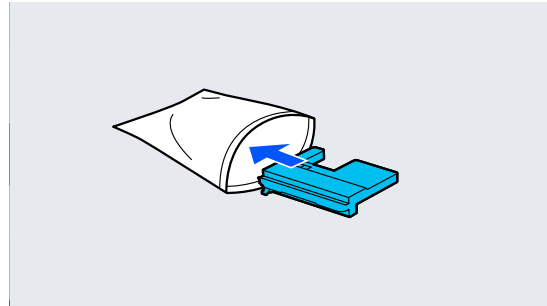

**Important:**

Do not tilt the Borderless Maintenance Box until the bag's press seal has been firmly closed. Failure to observe this precaution could cause ink to leak.

- 6** Carefully insert the new Borderless Maintenance Box.

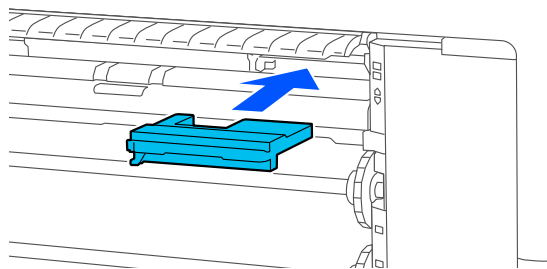

## Maintenance

- 7** Set the paper support to the position shown in the illustration, and then close the flap.

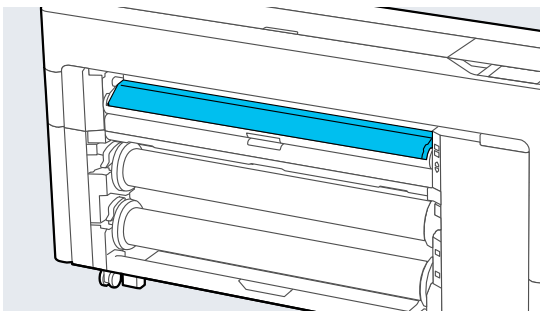
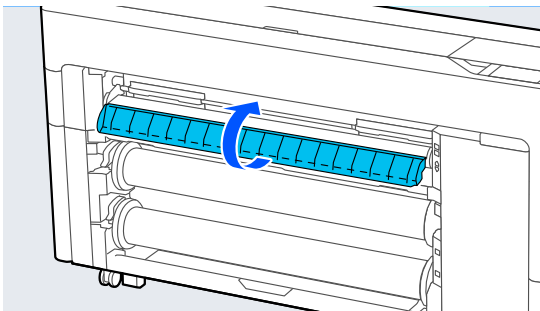
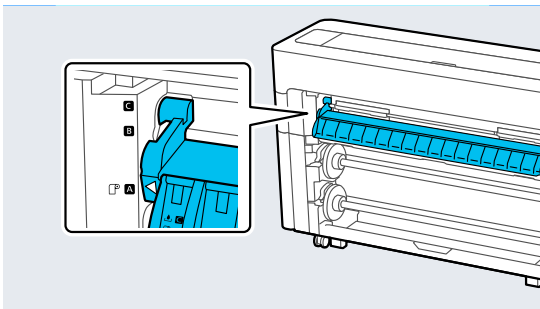
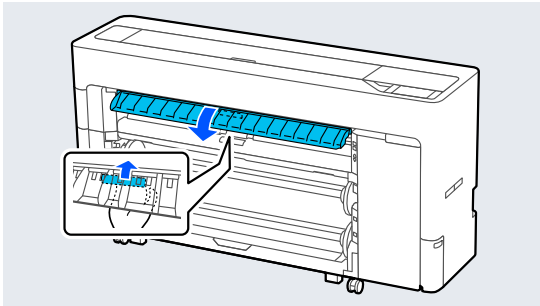

### Replacing the auto cutter blade

Replace the auto cutter blade if the paper is not cut cleanly or if the edges of the cut sections are fluffy.

Supported auto cutter blades

“Options and Consumable Products” on page 214

Use a cross-head screwdriver to replace the auto cutter blade. Make sure you have a cross-head screwdriver with you before replacing the cutter.

**!** **Important:**

*Take care not to damage the cutter blade. Dropping it or knocking it against hard objects may chip the blade.*

- 1** Remove any paper from the printer.
- “Removing Roll 1/Roll paper” on page 44
  - “Removing Roll 2 (Except for the SC-P6500E Series/SC-T3700E Series)” on page 48
  - “Removing Cut Sheets/Poster Board” on page 56

- 2** Press **Menu - Maintenance - Replace Auto cutter blade**.

- 3** Open the maintenance cover.

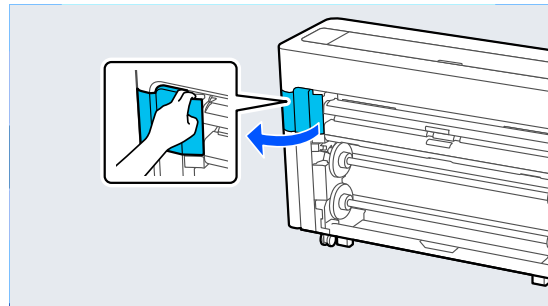

- 4** Loosen the screw that secures the cutter with the cross-head screwdriver.

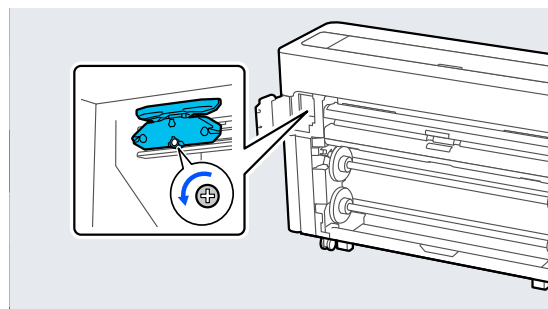

## Maintenance

- 5** Remove the old auto cutter blade from the printer.

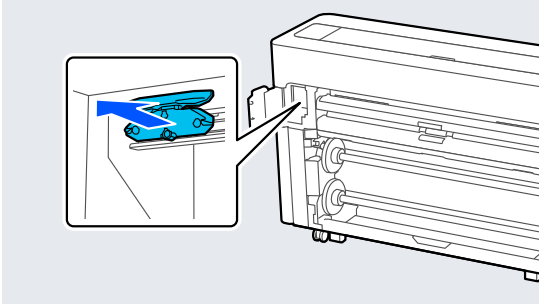

**!** **Caution:**

*Do not store the auto cutter blade within the reach of children. The blade of the auto cutter blade could cause an injury. Pay careful attention when replacing the auto cutter blade.*

- 6** Install the new auto cutter blade with the protective material still attached.

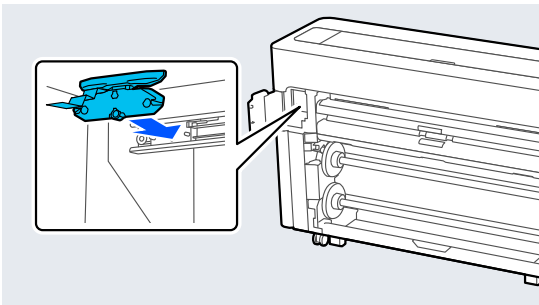

- 7** Tighten the screw that secures the cutter with the cross-head screwdriver.

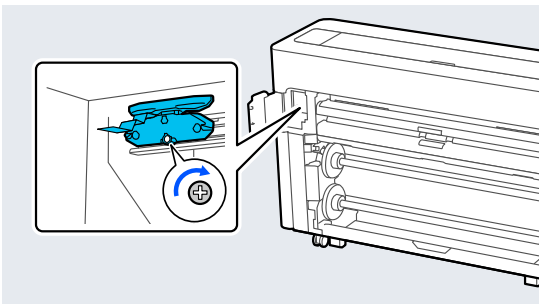

**!** **Important:**

*Screw the cutter firmly, otherwise the auto cutter blade position may be slightly shifted or skewed.*

- 8** Close the maintenance cover.

- 9** After replacing the cutter, press **OK**.

When the control panel returns to the screen displayed before you started this procedure, remove the auto cutter blade protector that has dropped inside the maintenance cover.

## Maintenance

# Cleaning the Printer

To keep your printer in optimum operating condition, clean it regularly (about once a month).

## Cleaning the outside

- 1 Remove any paper from the printer.
- 2 Make sure the printer is turned off and the screen has turned off, and then unplug the power cable from the outlet.
- 3 Use a soft, clean cloth to carefully remove any dust or dirt.

To prevent dust from accumulating, be sure to clean the following areas on the back and sides.

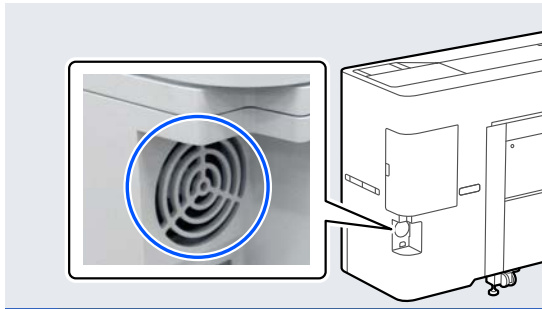

If the printer is particularly dirty, dampen the cloth with water containing a small amount of neutral detergent, and then firmly wring the cloth dry before using it to wipe the printer's surface. Next, use a dry cloth to wipe away any remaining moisture.

### **!** Important:

*Never use benzene, thinners, or alcohol to clean the printer. They could cause discoloration and deformities.*

## Cleaning the inside

Clean the pressure rollers if prints are smudged or soiled.

Ink and particles of paper adhering to the platen should be removed, as they may otherwise soil the paper.

### **!** Important:

*Failure to remove dust and particles of paper from the platen could result in clogged nozzles or damage to the print head.*

## Cleaning the roller

Follow the steps below to clean the roller by feeding plain paper.

- 1 Turn on the printer, and load it with the widest available roll paper.  
[📄 “Loading and Removing the Roll Paper” on page 42](#)
- 2 Press **⏪ - Forward**.  
Paper is fed while **Forward** is pressed. If the paper is not soiled, cleaning is complete.
- 3 Cut the paper after cleaning is done.  
Press **⏪ - Cut** to cut the paper.

## Cleaning Inside the Printer

- 1 Make sure the printer is turned off and the screen has turned off, and then unplug the power cable from the outlet.
- 2 Leave the printer for a minute.
- 3 Open the printer cover and use a soft, clean cloth to carefully clean away any dust or dirt inside the printer.

Thoroughly wipe the area shown in blue in the illustration below. To avoid spreading the dirt, wipe from the top to the bottom. If the printer is particularly dirty, dampen the cloth with water containing a small amount of neutral detergent, and then firmly wring the cloth dry before using it to wipe the printer's surface. Then, dry off the inside of the printer with a dry, soft cloth.

### **!** Important:

*Do not touch the rollers or ink tubes while cleaning. Doing so may cause a malfunction or soiled prints.*

## Maintenance

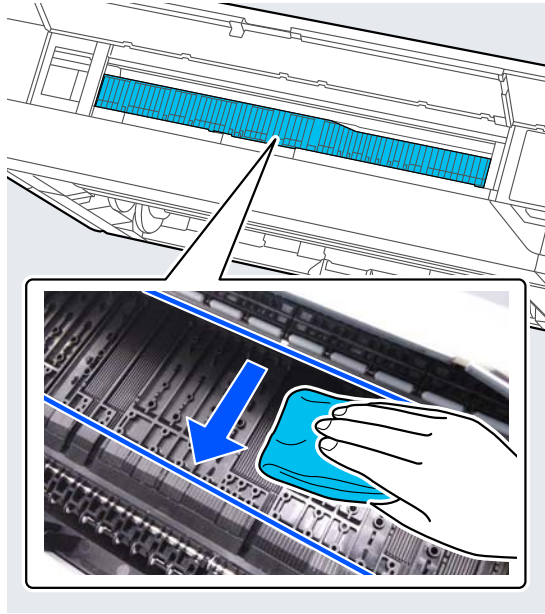

**Note:**

The part shown in the following illustration gets dirty easily, so be sure to wipe it thoroughly.

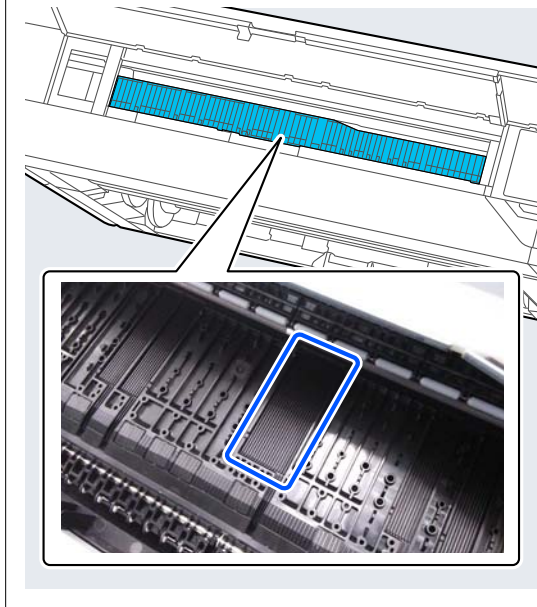

4

If any paper particles (that looks like white powder) accumulates on the platen, use something like a cocktail stick to push it in.

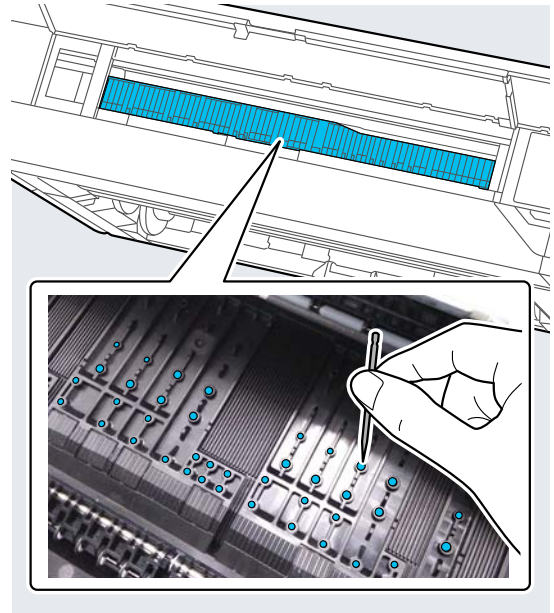

5

The reverse side of the printed paper is soiled, use a cleaning stick to wipe the area shown below from the back to the front.

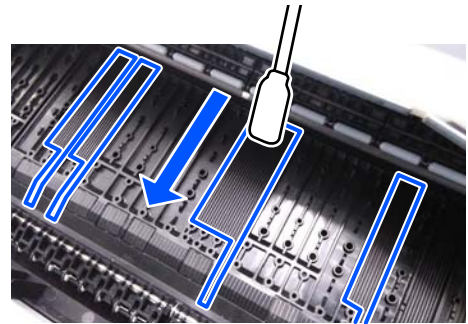

6

After cleaning, close the printer cover.

## Problem Solver

---

# Problem Solver

---

## When a Message is Displayed

If one of the following messages is displayed, read and follow the instructions below.

Messages	What to do
Change paper settings Paper setting in the printer driver is different from paper information registered in the printer. Change paper setting from the application or the driver. For details, see your documentation.	To change paper information that was registered using Epson Media Installer, load the paper and then use the control panel.  You can also use Epson Media Installer to change paper information for paper that has not been loaded.  However, you may not be able to change the paper information depending on the version of Epson Media Installer you are using.
TCP/IP configuration failed The combination of the IP address and the subnet mask is invalid. See your documentation for more details.	Enter the correct values for the IP address and the default gateway. Check with your network administrator if you do not know the correct values.

## Problem Solver

# When an Error Message and Error Code are Displayed

Error messages	What to do
<p>A printer part needs to be replaced. Contact Epson Support. For details, see your documentation.</p> <p>XXXXXXXX (Where XXXXXXXX is a 6-digit or 8-digit alphanumeric code.)</p>	<p>A part used in the printer is nearing the end of its service life.</p> <p>Contact your dealer or Epson Support and tell them the maintenance request code.</p> <p>This cannot be cleared until the part is replaced. A printer error occurs if you continue to use the printer.</p>
<p>Printer error. Turn power off and on again. If the problem persists, contact Epson Support.</p> <p>XXXXXXXX (Where XXXXXXXX is a 6-digit or 8-digit alphanumeric code.)</p>	<p>An error message is displayed in the following situations.</p> <ul style="list-style-type: none"> <li><input type="checkbox"/> The power cable is not connected securely</li> <li><input type="checkbox"/> An error that cannot be cleared occurs</li> </ul> <p>When a printer error occurs, the printer automatically stops printing. Turn off the printer, disconnect the power cable from the outlet and from the DC inlet on the printer, and then reconnect. Repeat this several times if the error continues to occur.</p> <p>If the same call for service is displayed on the LCD panel, contact your dealer or EpsonSupport for assistance. Tell them the call for service code is "XXXXXXXX".</p>

## Problem Solver

# Troubleshooting

## You cannot print (because the printer does not work)

### The printer does not turn on.

■ **Is the power cable plugged into the electrical outlet or the printer?**

Make sure the power cable is securely plugged into the printer.

■ **Is there a problem with the power outlet?**

Make sure your outlet works by connecting the power cable for another electric product.

### The printer turns off automatically.

■ **Is Power Off Timer enabled?**

To prevent the printer turning off automatically, select **Off**.

 ["General Settings" on page 147](#)

### The printer driver is not installed properly (Windows).

■ **Is the icon for this printer displayed in the Devices and Printers/Printers/Printers and Faxes folder?**

- Yes  
The printer driver is installed. See the "The printer is not communicating with the computer" section.
- No  
The printer driver is not installed. Install the printer driver.

■ **Does the printer port setting match the printer connection port?**

Check the printer port.

Click the **Port** tab in the printer Properties dialog and check the option selected for **Print to the following port(s)**.

- USB: **USBxxx** (x stands for the port number) for the USB connection
- Network: The correct IP address for the network connection

If it is not indicated, the printer driver is not installed correctly. Delete and reinstall the printer driver.

### The printer driver is not installed properly (Mac).

■ **Is the printer added to the printer list?**

Click **System Preferences - Printers & Scanners** (or **Print & Fax**) from the Apple menu.

If the printer name is not displayed, add the printer.

### The printer is not communicating with the computer.

■ **Is the cable plugged in properly?**

Confirm that the interface cable is securely connected to both the printer port and the computer. Also, make sure the cable is not broken nor bent. If you have a spare cable, try connecting with the spare cable.

■ **Does the interface cable specification match the specifications for the computer?**

Make sure the interface cable specifications match the specifications for the printer and the computer.

 ["System Requirements" on page 237](#)

■ **When using a USB hub, is it being used correctly?**

In the USB specification, daisy-chains of up to five USB hubs are possible. However, we recommend that you connect the printer to the first hub connected directly to the computer. Depending on the hub you are using, the operation of the printer may become unstable. If this should occur, plug the USB cable directly into your computer's USB port.

## Problem Solver

### ■ Is the USB hub recognized correctly?

Make sure the USB hub is recognized correctly on the computer. If the computer correctly detects the USB hub, disconnect all USB hubs from the computer and connect the printer directly to the computer USB port. Ask the USB hub manufacturer about USB hub operation.

## You cannot print under the network environment.

### ■ Are the network settings correct?

Ask your network administrator for the network settings.

### ■ Connect the printer directly to the computer using a USB cable, and then try to print.

If you are able to print via USB, there is a problem with network settings. Ask your system administrator, or refer to the manual for your network system. If you cannot print via USB, see the appropriate section in this User's Guide.

### ■ Are you using a wired LAN connection with a device that supports IEEE802.3az (Power Saving Ethernet)?

When using a wired LAN connection with a device that supports IEEE802.3az (Energy Efficient Ethernet, Power Saving Ethernet), the connection may become unstable, connection may not be possible, or the communication speed may be slow. Follow the steps below to disable IEEE802.3az on your computer and printer before connecting.

- (1) Disconnect the LAN cables from the computer and the printer.
- (2) Disable IEEE802.3az if it is enabled on your computer.
- (3) Connect the computer and printer directly with a LAN cable.
- (4) On the printer, check the printer's IP address in **Menu - General Settings - Network Settings - Connection Check**.
- (5) On the computer, start Web Config. Open a web browser, and then enter the printer's IP address.
- (6) Select **Network Settings - Ethernet**.
- (7) Set **IEEE 802.3az** to **Off**.
- (8) Click **Next**.
- (9) Click **Settings**.
- (10) Disconnect the LAN cable that connects to computer to the printer.
- (11) Enable IEEE802.3az on your computer if you disabled it in step 2.
- (12) Connect the LAN cables you disconnected in step 1 to the computer and printer.

If this problem continues to occur after following the steps above, it may be being caused by a device other than the printer.

## The printer has an error.

### ■ View the message displayed on the control panel.

 ["When a Message is Displayed" on page 188](#)

## Problem Solver

### The printer stops printing.

#### ■ Does the current printer status show Paused? (Windows)

If you stop printing or the printer stops printing because of an error, the print queue enters a **Pause** status. You cannot print in this status.

Double-click the printer icon in the **Devices and Printers**, **Printers**, or **Printers and Faxes** folder; if printing is paused, open the **Printer** menu and clear the **Pause** check box.

#### ■ Does the current printer status show Paused? (Mac)

Open the status dialog for your printer and check whether printing is paused.

(1) Select **System Preferences > Printers & Scanners** (or **Print & Fax**) > **Open Print Queue** > from the **Apple** menu.

(2) Double-click the icon for any printer that is **Paused**.

(3) Click **Resume Printer**.

#### ■ Are you using the Adobe® PostScript® 3™ expansion unit?

Printing using the Adobe® PostScript® 3™ expansion unit may have failed or been interrupted. See the following for more details on the problem and some possible solutions.

[🔗 "Adobe® PostScript® 3™ Expansion Unit" on page 78](#)

### Your problem is not listed here.

#### ■ Decide whether the trouble is caused by the printer driver or the application. (Windows)

Perform a test print from the printer driver so that you can check that the connection between the printer and computer is correct and the printer driver settings are correct.

(1) Make sure that the printer is turned on and in ready status, and load A4 or larger paper.

(2) Open the **Devices and Printers**, **Printers**, or **Printers and Faxes** folder.

(3) Right-click the printer icon, and select **Properties**.

(4) In the Properties dialog, select the **General** tab and click **Print Test Page**.

After a while the printer starts to print a test page.

If the test page is printed correctly, the connection between the printer and computer is correct. Go to the next section.

If the test page is not printed correctly, check the items above again.

[🔗 "You cannot print \(because the printer does not work\)" on page 190](#)

The "Driver Version" shown on the test page is the version number of the Windows internal driver. This differs from the Epson printer driver version that you installed.

---

### The printer sounds like it is printing, but nothing prints

#### The print head moves, but nothing prints.

#### ■ Confirm the printer operation.

Print a nozzle check pattern. Because a nozzle check pattern can be printed without connecting to a computer, you can check the operations and print status for the printer.

[🔗 "Print Head Nozzle Check" on page 172](#)

Check the next section if the nozzle check pattern is not printed correctly.

## Problem Solver

- **Is the message *Motor self adjustment running* displayed on the control panel's screen?**

The printer adjusts the internal motor. Wait for a while without turning off the printer.

### The nozzle check pattern is not printed correctly.

- **Perform head cleaning.**

The nozzles may be clogged. Print a nozzle check pattern again after performing head cleaning.

 ["Print Head Cleaning" on page 173](#)

- **Has the printer been left unused for a long time?**

If the printer has not been used for a long time, the nozzles may have dried up and have been clogged.

Perform print head cleaning.

 ["Print Head Nozzle Check" on page 172](#)

### The prints are not what you expected

#### Print quality is poor, uneven, too light, or too dark.

- **Are the print head nozzles clogged?**

If the nozzles are clogged, specific nozzles do not fire ink and the print quality declines. Print a nozzle check pattern.

 ["Print Head Nozzle Check" on page 172](#)

- **Has Ruled Line Alignment been performed?**

With bidirectional printing, the print head prints while moving left and right. If the print head is misaligned, ruled lines may be misaligned accordingly. If vertical ruled lines are misaligned with bidirectional printing, perform Ruled Line Alignment.

 ["Ruled Line Alignment" on page 176](#)

- **Are you using a genuine Epson ink cartridge/ink supply unit?**

This printer is developed for use with Epson ink cartridges/ink supply units. If you use non-Epson ink cartridges, printouts may be faint, or the color of the printed image may be changed because the remaining ink level is not correctly detected. Be sure to use the correct ink cartridge/ink supply unit.

- **Are you using an old ink cartridge/ink supply unit?**

The print quality declines when an old ink cartridge/ink supply unit is used. Replace the old ink cartridge/ink supply unit with a new one. We recommend using all the ink in the cartridge/ink supply unit before the expiry date printed on the package (within a year of installation in the printer).

- **Have the ink cartridges/ink supply units been shaken?**

The ink cartridges/ink supply units for this printer contain pigment inks. Shake the cartridges thoroughly before installing them in the printer.

 ["Replacing Ink Cartridges \(Except for the SC-P8500DL Series/SC-T7700DL Series\)" on page 177](#)

 ["Replacing Ink Supply Units \(SC-P8500DL Series/SC-T7700DL Series Only\)" on page 179](#)

- **Is the Media Type setting correct?**

Print quality can be affected if the media settings in the printer driver/on the printer and the actual paper do not match. Be sure to match the media type setting with the paper that is loaded in the printer.

- **Did you select a low quality mode (such as Speed) as the Print Quality?**

If the options selected for **Print Quality > Quality Options** place priority on speed, quality will be sacrificed for print speed, potentially causing print quality to decline. To improve print quality, select **Level** options that give priority to quality.

## Problem Solver

### ■ Are you printing on poster board?

Depending on the type of poster board, print quality may decline due to curves in the paper. Support the edges of the paper during printing to keep the paper horizontal.

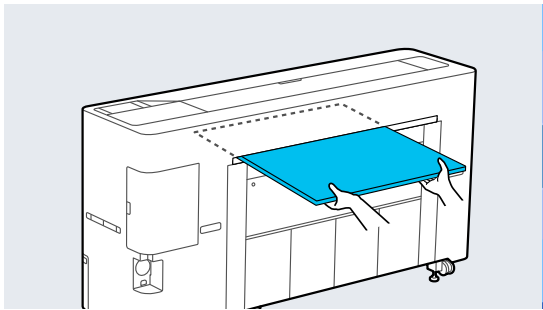

### ■ Is color management enabled?

Enable color management.

["Color Management Printing" on page 116](#)

### ■ Have you compared the printing result with the image on the display monitor?

Since monitors and printers produce colors differently, printed colors will not always match on-screen colors perfectly.

### ■ Did you open the printer cover while printing?

If the printer cover is opened while printing, the print head stops suddenly causing unevenness in the color. Do not open the printer cover while printing.

### ■ Is Ink is low. displayed in the control panel?

The print quality may decline when the ink is low. We recommend replacing the ink cartridge/ink supply unit with a new one. If there is a difference in color after replacing the ink cartridge/ink supply unit, try performing head cleaning a few times.

### ■ Are you printing at High Speed on commercially available paper?

If you have selected Custom Paper from **Paper Type** and the colors are uneven in your printouts, try the following.

- If you have not registered settings for the commercially available paper. See the following to register the settings.  
["Before Printing on Commercially Available Paper" on page 231](#)
- If you have registered settings for the commercially available paper. Perform uni-directional printing. Follow the steps below to clear the checkbox for **High Speed** in the printer driver.  
Windows: On the Printer Settings screen, select **Quality Options** from **Print Quality**.  
Mac: Select Print Settings from the list, and then select the **Advanced Color Settings** tab.

## The color is not exactly the same as another printer.

### ■ Colors vary depending on the printer type due to each printer's characteristics.

Because inks, printer drivers, and printer profiles are developed for each printer model, the colors printed by different printer models are not exactly the same.

You can achieve similar colors with the same color adjustment method or the same gamma setting by using the printer driver.

["Color Management Printing" on page 116](#)

To match the color precisely, use the color measurement device to perform color management.

## I am worried about different and/or uneven coloring the print quality at the leading edge of the paper.

### ■ Printing quality is dependent on multiple different factors as quality of paper and the printing environment. The margin at the leading edge of the paper can be small or colors may be uneven or different.

Print a larger margin at the leading edge of the paper.

["Paper Setting" on page 138](#)

## Problem Solver

- **In Quality Options from the printer driver, set Paper Edge Quality to Add Top Margin or Optimize Media Edge Print Quality.**

**Add Top Margin** prints everything in dual head mode, so it prints at the same print speed as normal, but the leading edge margin is larger than normal.

Since **Optimize Media Edge Print Quality** prints everything in single head mode, the print speed is slower than normal.

- **Are the settings for Top Margin too short?**

If the values set for **Top Margin** in the Paper menu are wider than the margins set in the application, priority will be given to the values selected for **Top Margin**. For example, if 15 mm is selected for the left and right margins in the printer's Paper menu and you print data created in an application that is set to fill the paper size, the 15 mm at the left and right sides of the page will not be printed.

 ["Printable area" on page 75](#)

### The print is not positioned properly on the media.

- **Have you specified the print area?**

Check the print area in the settings of the application and the printer.

- **Is the correct option selected for Page Size?**

If the option selected for **Roll Paper Width** or **Paper Size** in the printer driver does not match the paper loaded in the printer, the print may not be in the correct position or some of the data may be printed off the paper. In this case, check the print settings.

- **Is the paper skewed?**

If **Off** is selected for **Detect Paper Skew** in the Printer Settings menu, printing will continue even if the paper is skewed, resulting in data being printed off the paper. Select **ON** for **Detect Paper Skew** in the Printer Settings menu.

 ["General Settings" on page 147](#)

- **Does the print data fit within the paper width?**

Although under normal circumstances printing stops if the print image is wider than the paper, the printer may print outside the bounds of the paper when **Off** is selected for **Paper Size Check** in the Printer Settings menu. Change the setting to **ON**.

 ["Paper Setting" on page 138](#)

### Vertical ruled lines are misaligned.

- **Is the print head misaligned? (in bidirectional printing)**

With bidirectional printing, the print head prints while moving left and right. If the print head is misaligned, ruled lines may be misaligned accordingly. If vertical ruled lines are misaligned with bidirectional printing, perform Ruled Line Alignment.

 ["Ruled Line Alignment" on page 176](#)

### The printed surface is scuffed or soiled.

- **Is the paper too thick or too thin?**

Check that the paper specifications are compatible with this printer.

 ["Supported Media" on page 220](#)

For information about the media types and appropriate settings for printing on paper from other manufacturers or when using RIP software, see the documentation supplied with the paper, or contact the dealer of the paper or the manufacturer of the RIP.

- **Is the paper wrinkled or creased?**

Do not use old paper or paper with creases in it. Always use new paper.

## Problem Solver

### ■ Is the paper wavy or curled?

If the paper becomes wavy or warped due to changes in temperature or humidity, the paper may be scuffed.

Check the following points.

- Load the paper just before printing.
- Do not use wavy or curled paper.  
For roll paper, cut off the wavy or curled parts and then load it again.  
For cut sheets, use new paper.

### ■ Is the print head scuffing the printed surface?

If the printable surface of the paper is scuffed, set **Custom Paper Setting** from **General Settings** or **Platen Gap** from **Paper Setting** to widen the gap. If print results still do not improve, try changing the **Paper Eject Roller** or **Paper Eject Roller** from **General Settings** to **Use** in **Custom Paper Setting**. However, when using glossy paper, setting **Paper Eject Roller** to **Use** may damage the printable surface.

 ["Paper Setting" on page 138](#)

 ["General Settings" on page 147](#)

### ■ Is the print head scuffing the edge of the paper?

In Paper Setting, set **Roll 1** (known as **Roll** on the SC-P6500E Series/SC-T3700E Series) or **Roll 2 - Top/Bottom Margins** to **45 mm**.

 ["Paper Setting" on page 138](#)

### ■ Is the print head scuffing the trailing edge of the paper?

Depending on the paper itself as well as the environment during printing, storage conditions, and the content of the print data, the trailing edge may be scuffed when printing.

Create data with a wider bottom margin.

If the problem continues to occur, select **Optimize Edge Quality** in the printer driver before printing.

### ■ Is the print head scuffing the left or right edges of the paper?

Depending on the paper itself as well as the environment during printing, storage conditions, and the content of the print data, the left or right edges may be scuffed when printing.

Create data with a wider left or right margin. If the problem continues to occur, rotate the data 90 degrees in the printer driver or your software, and then print.

### ■ When printing multiple pages, is Auto Cut - Never Cut set?

If you print continuously without cutting the paper for each page, the pages may rub together causing scuffing to occur. Create data with a wider margin between pages.

### ■ Does the interior of the printer need cleaning?

The rollers may need cleaning. Clean the rollers by feeding and ejecting paper.

 ["Cleaning the inside" on page 186](#)

### ■ Try cleaning the area around the print head.

If the printing surface is dirty even after taking the measures described before this item, see the following to clean around the print head, caps, and wipers.

 ["Cleaning around the print head and caps" on page 196](#)

### ■ Widen the bottom margin.

Depending on the paper usage, storage conditions, and the content of the print data, the bottom edge may be scuffed when printing. In this situation it is best to create your data with a wider bottom margin.

## Cleaning around the print head and caps

If print head clogging cannot be cleared using automatic cleaning, clean the print head and the area around the caps.

## Problem Solver

### **Important:**

- ❑ *Never touch any parts or circuit boards other than those that need to be cleaned. Doing so may cause the printer to malfunction or print quality to decline.*
- ❑ *Always use new cleaning sticks. Re-using a stick that has already been used may actually apply dirt to the printer.*
- ❑ *Do not touch the tips of the cleaning sticks. Sebum may stick to it reducing the cleaning effect.*
- ❑ *Touch a metallic object before starting work to discharge any static electricity.*
- ❑ *Do not wipe the caps with an organic solvent such as alcohol. Doing so may damage the print head.*
- ❑ *Do not move the print head by hand. Failure to observe this precaution could damage the printer.*
- ❑ *If paper is loaded in the printer, we recommend removing it before starting work.*

### **Wiping the Print Head**

- 1** Select **Maintenance - Cleaning the Maintenance Parts - Wiping the Print Head**.

The print head moves to the cleaning position.

- 2** Open the maintenance cover.

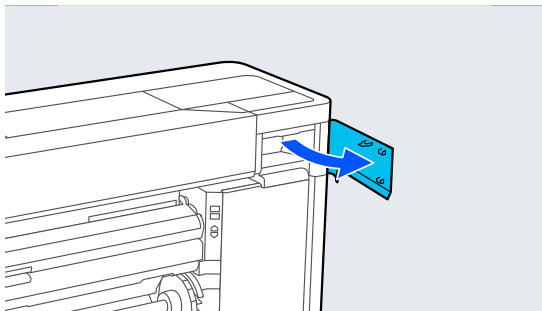

- 3** Use the cleaning stick to remove any ink, fluff, or trash.

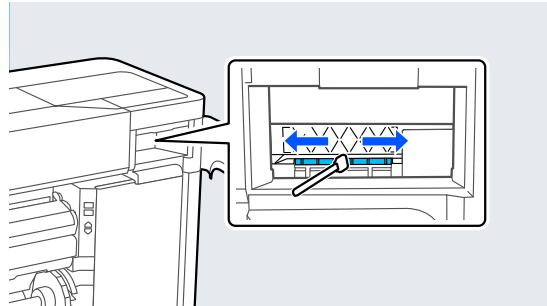

- 4** Close the maintenance cover.

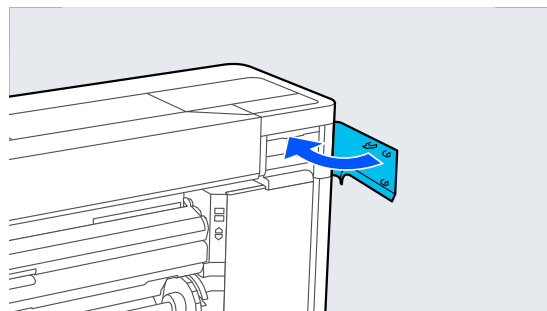

- 5** Go to the rear of the printer.

- 6** Open the port cover.

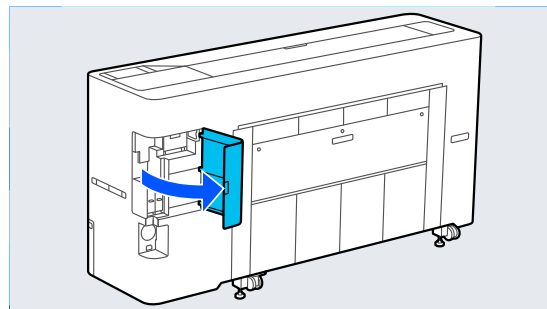

- 7** Open the rear maintenance cover.

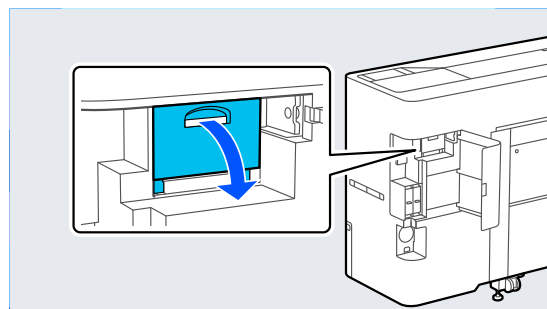

## Problem Solver

- 8** Clean the edges of the print head with a cleaning stick.

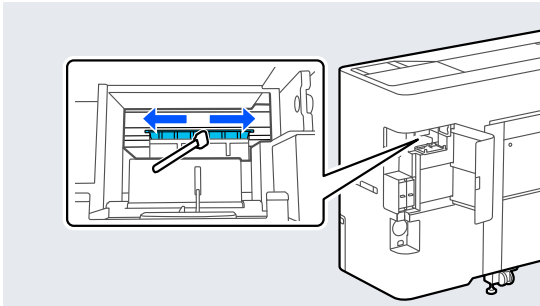

- 9** Close the rear maintenance cover.

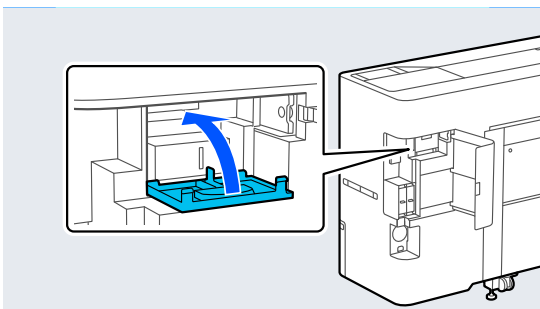

- 10** Close the port cover.

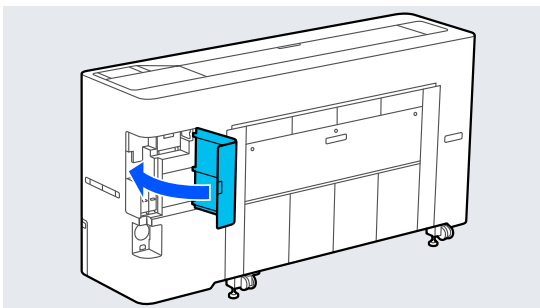

- 11** Press **OK** on the control panel.  
The print head returns to its original position.

### Wiping around the Cap

- 1** Select **Maintenance - Cleaning the Maintenance Parts - Wiping around the Cap**.

The print head moves to the cleaning position.  
Wait for the print head to stop moving.

- 2** Open the printer cover.

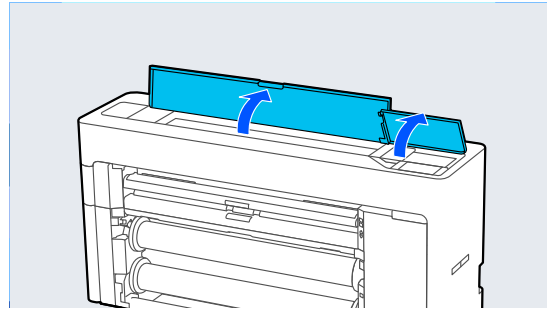

- 3** Remove the part shown in the figure.

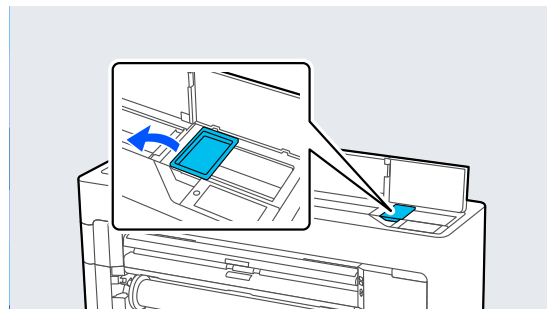

- 4** Use a new cleaning stick to wipe any dirt off the capping station.

- (1) Hold the cleaning stick so that it is vertical, and wipe the inner areas of all of the capping stations.

#### **!** Important:

*Do not press too hard on the edges or the area surrounding the caps with tweezers or cleaning sticks. Doing so could cause the parts to become deformed preventing capping from being performed correctly.*

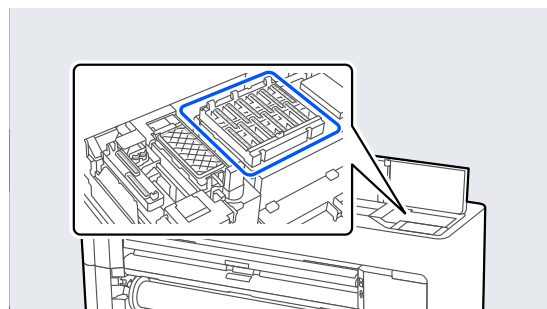

## Problem Solver

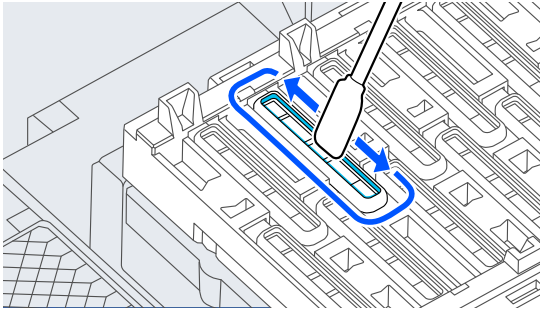
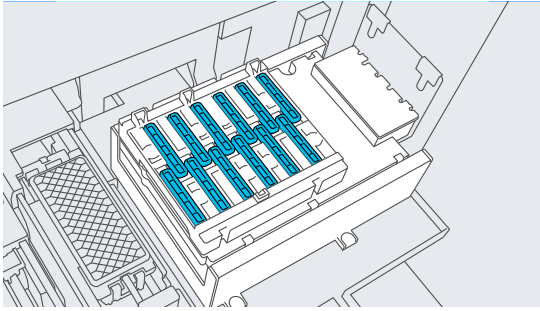

- (2) Hold the cleaning stick so that it is vertical, and wipe the inner areas of all of the capping stations.

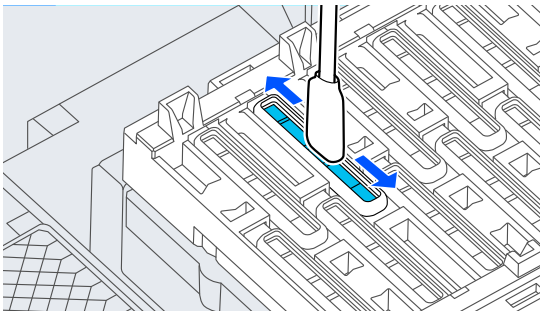

- (3) Hold the cleaning stick so that it is vertical, and wipe the outer areas of all of the capping stations.

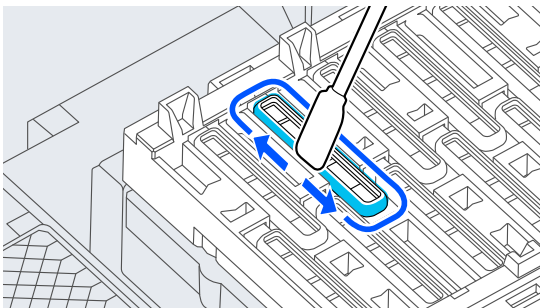

- (4) Wipe the edges of all of the capping stations with the flat surface of the cleaning stick.

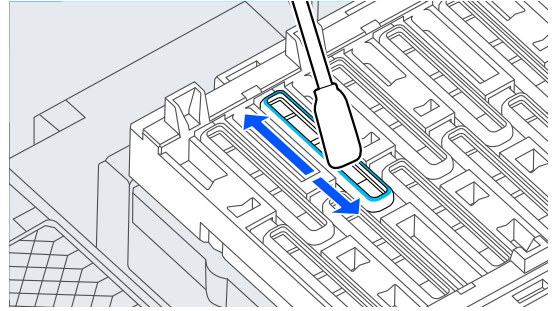

- (5) Hold the cleaning stick so that it is vertical, and wipe the guides of all of the capping stations.

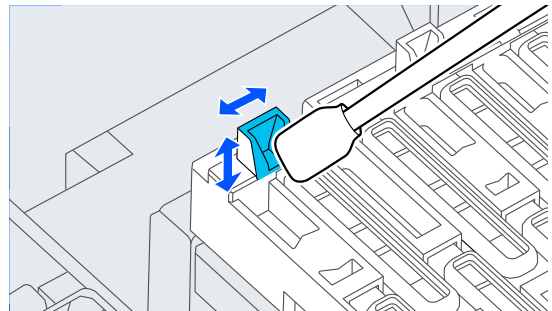
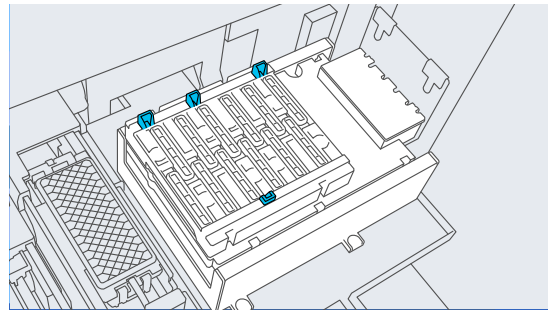

- (6) If there is any fluff or dust in the caps, remove it with the tip of the cleaning stick or with tweezers.

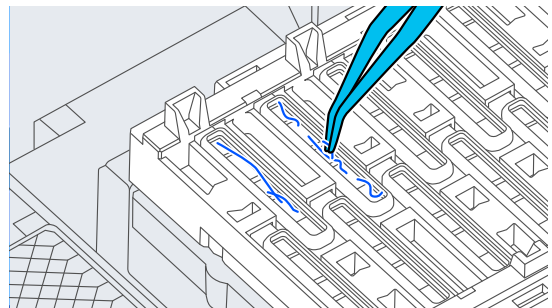

## Problem Solver

- 5** Use a new cleaning stick to wipe any dirt off the wiper.

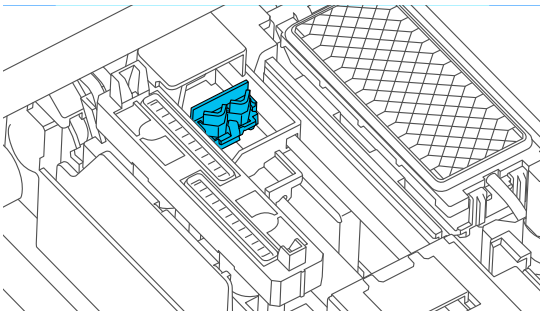
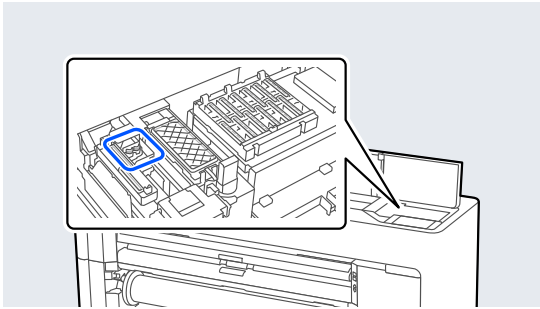

- (1) Wipe around the wiper on the front.

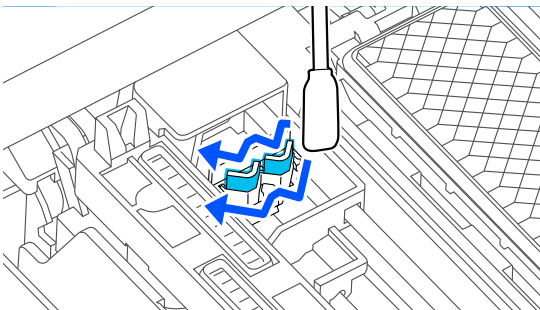

- (2) Wipe around the wiper at the back.

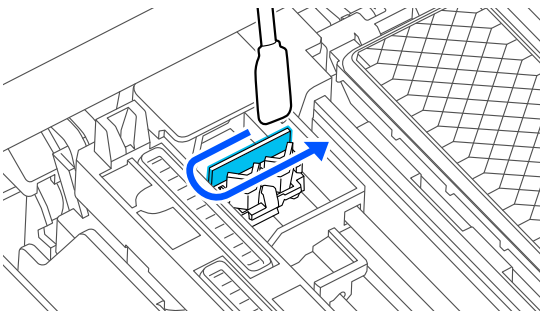

- (3) Wipe the edges of the wipers.

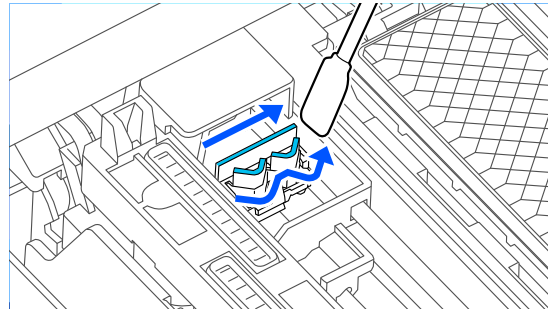

- 6** Use a new cleaning stick to wipe any dirt off the suction caps.

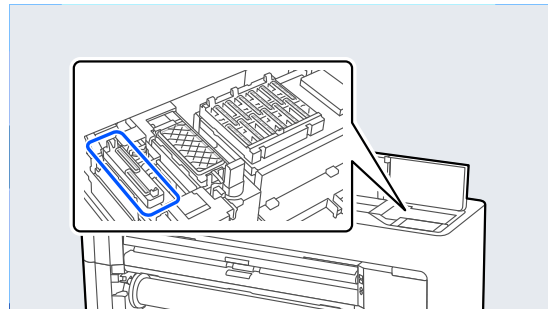

- (1) Hold the cleaning stick so that it is vertical, and wipe the outer areas of all of the suction caps.

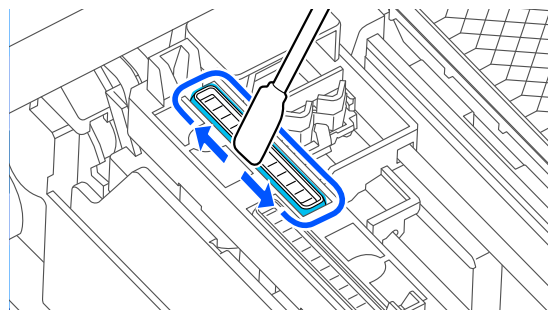

- (2) Wipe the edges of all of the suction caps with the flat surface of the cleaning stick.

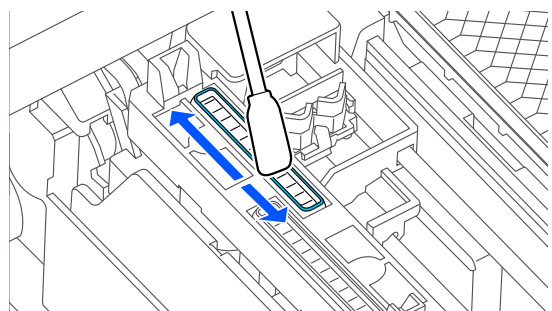

## Problem Solver

- (3) Hold the cleaning stick so that it is vertical, and wipe the guides of all of the suction caps.

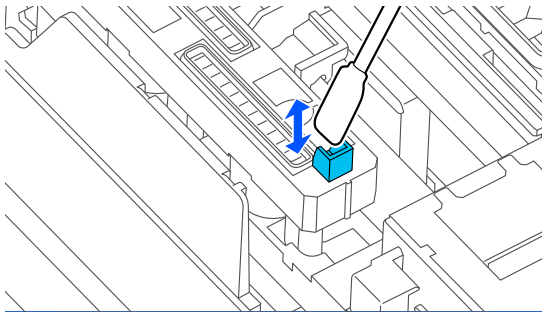
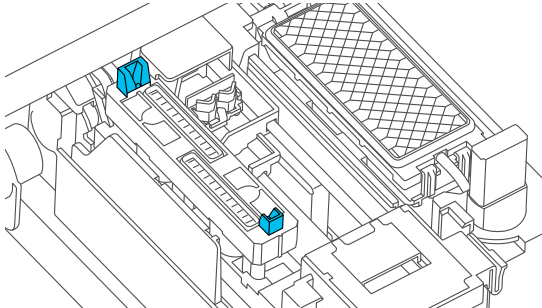

- (4) If there is any fluff or dust in the caps, remove it with the tip of the cleaning stick or with tweezers.

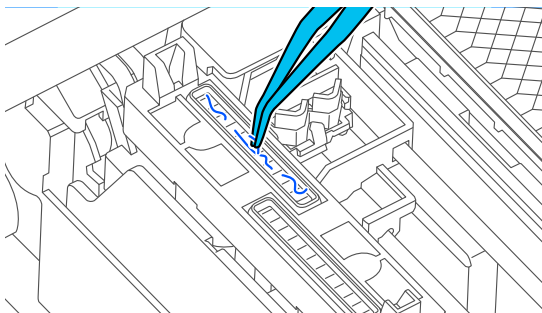

- 7** Install the part shown in the illustration.

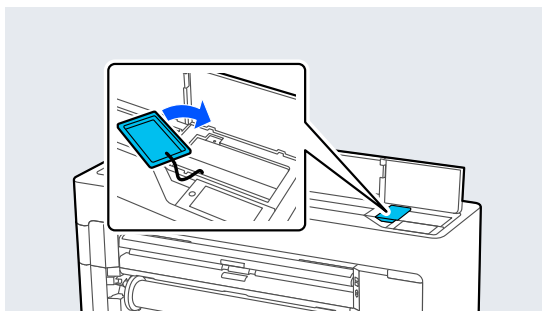

- 8** Close the printer cover.

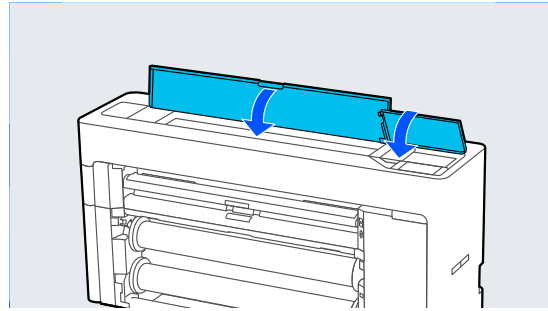

- 9** Press **OK** on the control panel.

The print head returns to its original position. Cleaning is performed automatically if the print head is clogged.

### The paper is wrinkled.

- **Are you using the printer at normal room temperature?**

Epson special media should be used at normal room temperature (temperature: 15 to 25°C, humidity: 40 to 60%). For information about paper such as thin paper from other manufacturers that requires special handling, see the documentation supplied with the paper.

- **When using non-Epson special media, have you made the paper configuration?**

When using non-Epson special media, configure the paper characteristics (custom paper) before printing.

 ["Before Printing on Commercially Available Paper" on page 231](#)

### Print outs are wrinkled



## Problem Solver

### ■ Dry the paper after printing

Drying the paper after printing may help to reduce wrinkles in the paper.

Rolling out the paper and stretching it can also improve any wrinkles in the paper.

### ■ Lower the ink density used when printing

The paper may wrinkle when printing using high density ink. Lower the ink density in Advanced Media Control in the driver.

### ■ Lower the resolution used when printing

The paper may wrinkle when printing at a high resolution. Lower the resolution in "Print Quality" from the driver.

## The printable surface is scratched

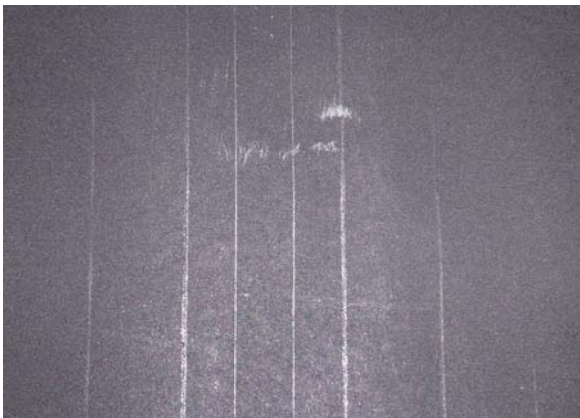

### ■ Disable the paper eject roller.

Select **Paper Setting - Roll 1 (Roll)/Roll 2/Cut Sheet - Advanced Paper Settings - Paper Eject Roller - Do Not Use** on the control panel.

However, if you do not use the paper eject roller, the print head may rub the printable surface. If the printable surface is rubbed, set **General Settings** or **Paper Setting** on the control panel to widen the platen gap.

## The reverse side of the printed paper is soiled.

### ■ Select ON for Paper Size Check in the Settings menu

Although printing normally stops if the print image is wider than the paper, when **OFF** is selected for **Paper Size Check** in the Printer Settings menu, the printer may print beyond the edges of the paper, getting ink on the inside of the printer in the process. This can be prevented by changing the setting to **ON**.

[🔗 "Paper Setting" on page 138](#)

[🔗 "Cleaning the inside" on page 186](#)

### ■ Is ink dry on the printed surface?

Depending on the printing density and paper type, the ink may take a while to dry. Do not stack the paper until the printed surface is dry.

### ■ Does the platen need cleaning?

Clean the inside of the printer.

[🔗 "Cleaning the inside" on page 186](#)

## Too much ink is fired.

### ■ Is the Media Type setting correct?

Make sure that the printer driver's **Media Type** settings match the paper that you are using. The amount of ink to be fired is controlled according to the media type. If the settings do not match the paper loaded, too much ink may be fired.

### ■ Is the Color Density setting appropriate?

Lower the density of the ink in the **Advanced Media Control** dialog box from the printer driver. The printer may be printing with too much ink for some paper. See the printer driver help for more details on the Advanced Media Control dialog box.

### ■ Are you printing on tracing paper?

If too much ink is used when printing in **Gray** on tracing paper, you may get better results by choosing a lower print density in the **Advanced Media Control** dialog box of the printer driver.

## Problem Solver

### Margins appear in borderless printing.

#### ■ Are the settings for the print data in the application correct?

Make sure that the paper settings in the application are correct as well as in the printer driver.

 ["Setting Loaded Paper" on page 56](#)

#### ■ Are the paper settings correct?

Make sure that the paper settings of the printer match the paper that you are using.

#### ■ Have you changed the amount of enlargement?

Adjust the amount of enlargement for borderless printing. Margins may appear if you set the amount of enlargement to **Standard**.

 ["Borderless Printing" on page 96](#)

#### ■ Is the paper stored correctly?

The paper may expand or contract if it is not stored correctly so that margins appear even when borderless is set. See the documentation supplied with the paper for more information on the storage method.

#### ■ Are you using paper that supports borderless printing?

Paper that does not support borderless printing may expand or contract while printing so that margins appear even when borderless is set. We recommend using paper that is designed to support borderless printing.

#### ■ Try adjusting the cutter.

When there are margins on the top and bottom of the roll paper while performing borderless printing, try performing **Adjust Cut Position** from General Settings. It may reduce the margins.

 ["General Settings" on page 147](#)

### Feeding or ejecting problems

#### Unable to feed or eject paper.

#### ■ Is the paper loaded in the correct position?

See the following for the correct paper loading positions.

 ["Loading and Removing the Roll Paper" on page 42](#)

 ["Loading and Removing Cut Sheets/Poster Board" on page 50](#)

If the paper is loaded correctly, check the condition of the paper that you are using.

#### ■ Is the paper loaded in the correct direction?

Load poster board in a portrait orientation. If they are not loaded in the correct direction, the paper may not be recognized and an error may occur.

 ["Loading and Removing Cut Sheets/Poster Board" on page 50](#)

#### ■ Is the paper wrinkled or creased?

Do not use old paper or paper with creases in it. Always use new paper.

#### ■ Is the paper damp?

Do not use paper that is damp. Also, Epson special media should be left in the bag until you intend to use it. If it is left out for a long time, the paper curls up and gets damp so that it does not feed properly.

#### ■ Is the paper wavy or curled?

If changes in temperature and humidity cause paper to become wavy or curled, the printer may not be able to recognize the paper size correctly.

Check the following points.

- Load the paper just before printing.
- Do not use wavy or curled paper. For roll paper, cut off the wavy or curled parts and then load it again. For cut sheets, use new paper.

## Problem Solver

### ■ Is the paper too thick or too thin?

Check that the paper specifications are compatible with this printer. For information about the media types and appropriate settings for printing on paper from other manufacturers or when using RIP software, see the documentation supplied with the paper, or contact the dealer of the paper or the manufacturer of the RIP.

### ■ Are you using the printer at normal room temperature?

Epson special media should be used at normal room temperature (temperature: 15 to 25°C, humidity: 40 to 60%).

### ■ Is paper jammed in the printer?

Open the printer cover of the printer and check that there are no paper jams or foreign objects in the printer. If paper is jammed, perform **Maintenance - Remove Paper**.

### ■ Is the paper suction too strong?

If you continue to have problems with ejected paper, try lowering the Paper Suction (the amount of suction used to keep the paper on the paper feed path).

 ["Paper Setting" on page 138](#)

### ■ Are you using paper that curls easily?

When using paper that curls easily, make sure you are in an environment with a room temperature of 23 degrees or higher.

## Roll marks are left on the paper

### ■ Is roll paper being fed using Auto Loading?

Depending on the paper, roll marks may be left on the paper when it is fed automatically or when switching rolls. In this situation, take the following measures.

- Select **Menu - General Settings - Printer Settings - Paper Source Settings - Roll Paper Setup - Auto Loading - Off** to feed the roll paper manually.  
 ["Feeding Roll Paper Manually" on page 63](#)
- If roll marks remain even after manual feeding, feed the paper manually until you hear the printer beep twice.
- When printing using roll switching, roll marks may be left on the paper when switching rolls. From **Menu - General Settings - Printer Settings - Roll Paper Setup - Paper Source Settings - Roll Switching**, select **Roll 1** or **Roll 2**.

## Paper does not collect in the paper basket or is creased or folded when the paper basket is used.

### ■ Does the print job require a lot of ink, or is the humidity of the work environment high?

Depending on the job and the work environment, paper may not collect in the paper basket. Take the following measures as appropriate.

- Paper does not collect in the paper basket: Use your hands to lightly press the paper into the paper basket as it is ejected from the printer.
- The paper folds after it has been cut automatically: Select manual cutting and take the paper in both hands after it is cut.
- The paper wrinkles and does not collect well in the paper basket: Resume printing after closing the paper basket. Before the paper ejected from the printer touches the floor, take it in both hands and continue to lightly support it until printing is complete.

## Roll paper jam

To remove jammed paper, follow the steps below:

## Problem Solver

- 1 Cut the paper at the position shown in the illustration.

### Roll 1/Roll

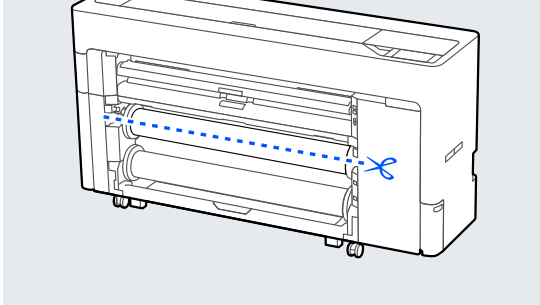

### Roll 2

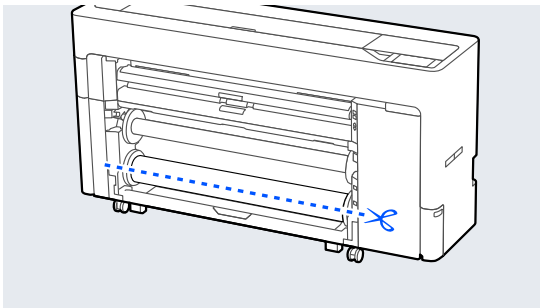

- 2 Open the printer cover.

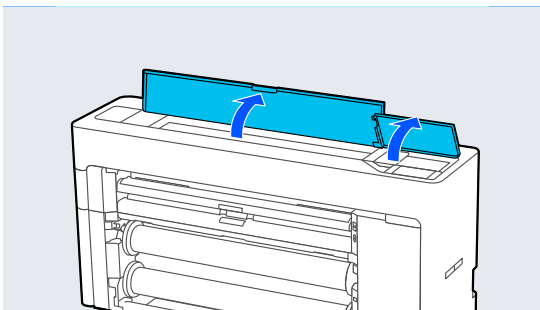

**!** **Important:**

Do not touch the cables around the print head. Doing so may cause a malfunction to occur.

- 3 If the print head is over the media, move it away from the jam.

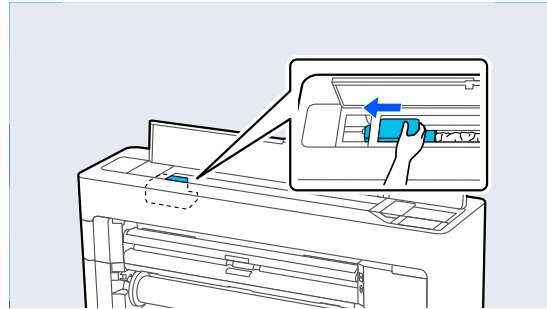

**!** **Important:**

Other than when you are clearing paper jams, do not touch the print head. If you touch the print head with your hand, static electricity may cause a malfunction.

- 4 Pull out the paper. Do not touch the parts shown in the illustration.

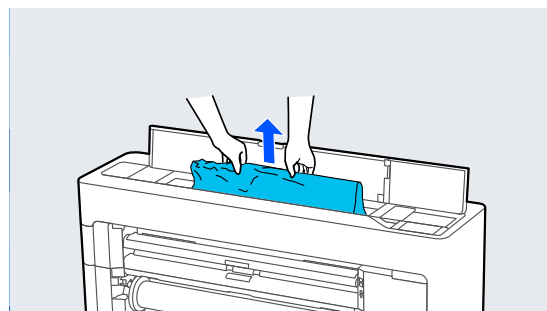
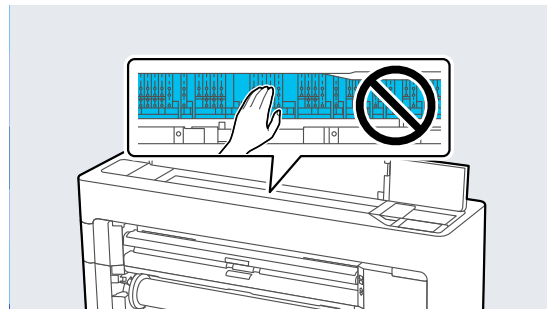

- 5 Close the printer cover.

## Problem Solver

- 6** If there is any paper left inside the printer, open the rear cover and remove the paper.

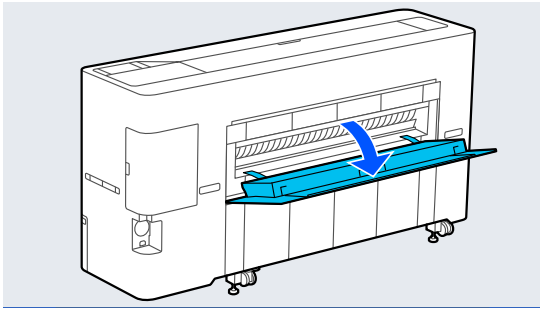

- 7** Turn the printer off and then back on.

- 8** Reload the paper and resume printing.

**!** **Important:**

*Before you reload the roll paper, cut the edge straight horizontally. Cut any wavy or wrinkled sections. If there is a problem at the edge, decreased print quality and paper jams may occur.*

### Cut sheets jam

To remove jammed paper, follow the steps below:

- 1** Open the printer cover.

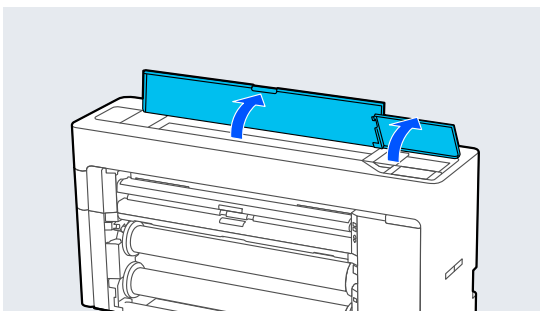

**!** **Important:**

*Do not touch the cables around the print head. Doing so may cause a malfunction to occur.*

- 2** If the print head is over the media, move it away from the jam.

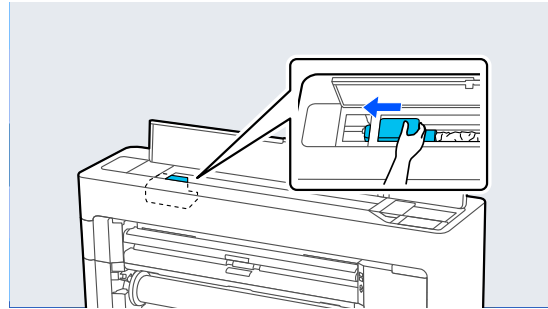

**!** **Important:**

*Other than when you are clearing paper jams, do not touch the print head. If you touch the print head static electricity may cause a malfunction.*

- 3** Pull out the paper.

Do not touch the parts shown in the illustration.

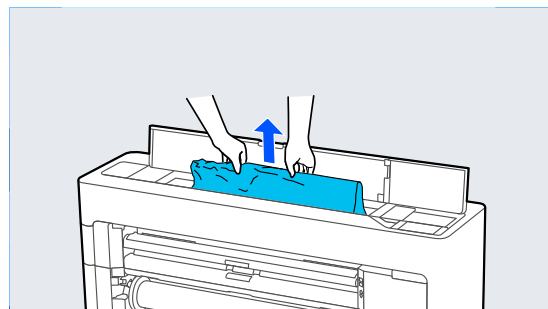
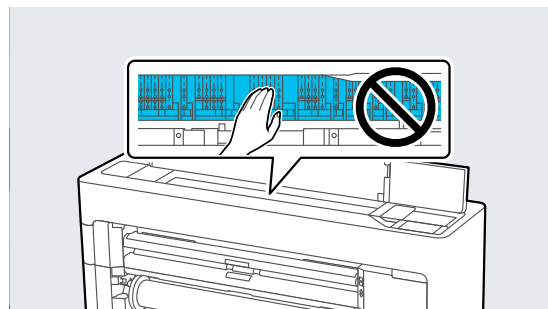

- 4** Close the printer cover.

- 5** Turn the printer off and then back on.

- 6** Reload the paper and resume printing.

## Problem Solver

### Original is jammed (SC-P8500DM Series/SC-T7700DM Series/SC-T5700DM Series only)

To remove a jammed original, follow the steps.

#### **Caution:**

When opening and closing the scanner cover, keep your hands away from the joint between the cover and the printer.

If your fingers or hands get caught, it could cause an injury.

#### 1 Open the scanner cover.

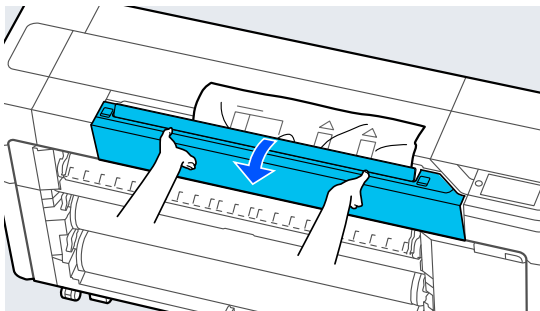
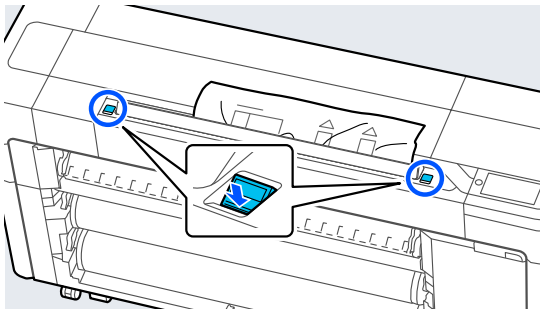

#### **Important:**

Do not lean against or place objects on the scanner cover.

#### 2 Remove the jammed original.

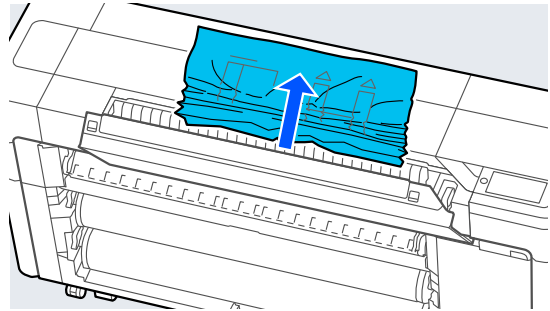

#### 3 Close the scanner cover.

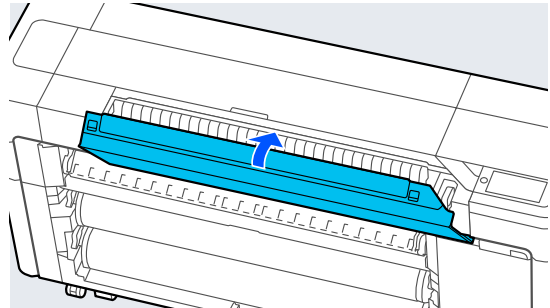

## Others

### The control panel display keeps turning off.

#### ■ Is the printer in sleep mode?

Sleep mode is exited if a print job is received or the  button on the control panel is pressed. The time before entering sleep mode can be changed in the General Settings menu.

 ["General Settings" on page 147](#)

### Color ink runs out quickly even when printing in the Black&White mode or when printing black data.

#### ■ Color ink is consumed during the head cleaning process.

If all nozzles are selected when you perform **Print Head Cleaning** or **Power Cleaning**, inks of all colors will be used. (Even if B&W mode is selected, all colors of ink are consumed during print head cleaning.)

 ["Print Head Cleaning" on page 173](#)

## Problem Solver

### The paper is not cut cleanly.

- Depending on the paper, if Quick Cut on the control panel is set to On, the paper may not be cut cleanly as shown below.



Select **General Settings - Printer Settings - Paper Source Settings - Roll Paper Setup - Cut Settings - Quick Cut - Off** from the control panel.

- **Replace the cutter.**

If the paper is not cut cleanly, replace the cutter.

 ["Replacing the auto cutter blade" on page 184](#)

### A light is visible inside the printer.

- **This is not a failure.**

The red light is a light inside the printer.

### The administrator password has been lost

- Should you forget the administrator password, contact your dealer or Epson Support.

### Head cleaning is performed automatically

- The printer may automatically perform head cleaning to ensure print quality.

### Cannot update the firmware for the printer

- **Are there any jobs in progress or outstanding jobs on the printer?**

Wait for the jobs to finish being processed or cancel the jobs.

### Printing stops when printing in a VPN (Virtual Private Network) environment

- **Try setting the network setting to 100Base-TX Auto.**

You can set this from Settings - General Settings - Network Settings - Quality Options on the control panel.

You can also change network settings in Web Config or Epson Device Admin.

- **Print using the SSD Unit. Store the print data in the SSD Unit before printing.**

Select Print after Transmission Completed or Print Mode - Save only in the printer driver's Hard Disk Unit Settings.

### The printer turned off due to a power cut

- **Turn off the printer, and then turn it back on.**

When the printer is not turned off normally, the print head may not be capped correctly. If the print head is left uncapped for a long time, the print quality may decline.

When you turn on the printer, capping is performed automatically after a few minutes.

Also, if the printer is turned off during calibration, data transmission and writing adjustment values may not be performed correctly. When the date is initialized, the adjustment values are also initialized.

## Problem Solver

### Copying or Scanning Problems (SC-P8500DM Series/ SC-T7700DM Series/ SC-T5700DM Series Only)

#### Lines Appear on Scanned or Copied Documents



Follow the steps below to clean the inside of the scanner. Dust or dirt that is stuck to the scanner's glass surface or the white board may cause unwanted lines or marks on copy results and scanned images.

If the scanner is very dirty, wipe it clean.

#### **Caution:**

When opening and closing the scanner cover, keep your hands away from the joint between the cover and the printer.

If your fingers or hands get caught, it could cause an injury.

#### **Important:**

- Do not use volatile chemicals, such as alcohol or paint thinners. Deformation or discoloration could occur.
- Do not apply liquids to or directly spray lubricant on the scanner. Otherwise the equipment and circuits may become damaged, so the printer may not operate correctly.

- 1 Open the scanner cover.

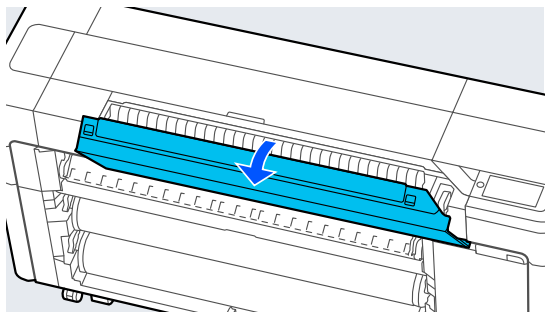
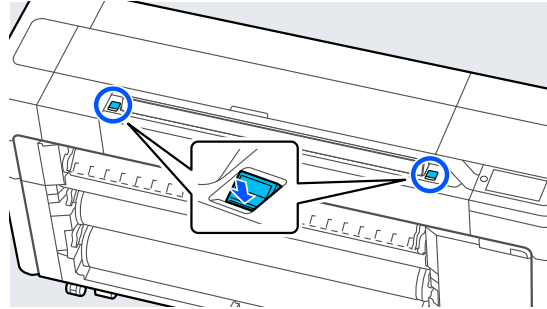

- 2 Use the clean side of a soft cloth to carefully wipe the scanner.



#### **Important:**

- Do not apply excessive force to glass surfaces.
- Do not use brushes or hard objects. They may scratch the glass surface and affect the scan quality.
- Do not directly spray cleaner onto the glass surface.

## Problem Solver

- 3** After you have finished cleaning, close the scanner cover.



### **Important:**

Close the scanner cover right after you have finished cleaning to prevent dust from getting inside.

## Unable to Properly Feed Originals

If the right side of the original's loading position is incorrect, the original cannot be fed properly.

Make sure the right edge of the original is lined up straight. If the document is not loaded straight, use the scanner edge guide.



If the original still cannot be fed properly, change **Original Size** or **Scan Size** to the standard size from **Auto Detect**.

■ **Is the original loaded with skew?**

Reload the original. If the original is loaded with skew, it cannot be fed properly.

■ **Is the original folded?**

Unfold the original.

If the original is folded while the printer is set to **Auto Detect** in **Original Size** or **Scan Size**, the width of the original may not be read correctly, which may cause the original to not feed properly.

■ **Clean inside of the scanner.**

If the printer is set to **Auto Detect** in **Original Size** or **Scan Size**, the width of the original may not be read correctly, which may cause the original to not feed properly.

How to Clean Inside the Scanner  ["Lines Appear on Scanned or Copied Documents" on page 209](#)

■ **You may be using an original that cannot be placed.**

See the following for details on originals that cannot be placed.

 ["Documents That Cannot Be Loaded" on page 130](#)

■ **Is the original loaded with skew?**

Reload the original. If the original is loaded with skew, it cannot be fed properly.

## Original Size or Scan Size are not recognized correctly

■ **Is Original Size or Scan Size set to Auto Detect?**

If **Original Size** or **Scan Size** is set to **Auto Detect**, the size of the original may not be detected correctly. Set **Original Size** or **Scan Size**.

■ **Clean inside of the scanner.**

If there is dust or dirt stuck to the scanner's glass surface or the white board, the size of the original may not be detected correctly. See the item below and follow the same procedures for cleaning.

 ["Lines Appear on Scanned or Copied Documents" on page 209](#)

## Copy Results are not Enlarged to the Width of the Roll Paper

■ **Is the reduce/enlargement copy setting set to Auto Fit Page - On?**

If **Auto Fit Page** is set to **On** in **Reduce/Enlarge** from the Copy menu, the scanner may not be able to detect the size of the original correctly, and the print result will not match the width of the roll paper. In **Advanced - Original Size**, specify the size of the original you loaded.

## Scanned Image Is Misaligned

■ **Change the direction that the original is loaded.**

Changing the direction that the original is loaded may improve scan results.

## Problem Solver

### ■ Is the original curled?

If the original is curled, smooth out the original and place it flat. Then scan the original.

### ■ Try Image Stitching Adjustment.

Doing **Image Stitching Adjustment** may improve scan results.

 ["Image Stitching Adjustment" on page 212](#)

### ■ Try using the optional carrier sheet.

Putting the original into the carrier sheet smooths out any wrinkles and may improve scan results.

## Scanned Image Is Blurred

### ■ Is Image Stitching Smoother set to On?

When **Image Stitching Smoother** is set to **On**, text and lines may be blurred at the points where the scans are joined.

If you are concerned about this issue, touch **Menu - General Settings - Scan Settings - Scan Options - Image Stitching Smoother** from the Home screen, and set this to **Off**.

### ■ Try Image Stitching Adjustment.

If the stitching for the scanned images is not aligned, any text or lines on the stitching may be blurred or fuzzy.

 ["Image Stitching Adjustment" on page 212](#)

## Color of Original (Background Color) Remains in Scanned Image or Shadows of Wrinkles Appear in Scanned Image

### ■ Are you using the optional carrier sheet?

When scanning with a carrier sheet, the background color may remain in the scan results or wrinkles may appear.

If you are concerned about these issues, follow the steps below to try to make adjustments in **Remove Background**.

- When copying  
Select **Copy - Basic Settings - Image Quality - Remove Background - Auto - Off** on the Home screen, and then set the adjustment value to a positive value from -4 to 4.

 ["Copy \(SC-P8500DM Series/SC-T7700DM Series/SC-T5700DM Series Only\)" on page 163](#)

- When scanning and saving to an email or folder  
Select **Scan** on the Home screen, and then select **Email** or **Network Folder/FTP** depending on the target location.  
Select **Scan Settings - Image Quality - Remove Background - Auto - Off**, and then set the adjustment value to a positive value between -4 to 4.

 ["Scan \(SC-P8500DM Series/SC-T7700DM Series/SC-T5700DM Series Only\)" on page 164](#)

- When saving scanned data to an external memory device  
Select **Scan - To Memory Device - Advanced - Image Quality - Remove Background - Auto - Off** on the Home screen, and then set the adjustment value to a positive value between -4 to 4.

 ["Scan \(SC-P8500DM Series/SC-T7700DM Series/SC-T5700DM Series Only\)" on page 164](#)

## Document Feed Adjustment

If the print results and the length of the original of copied or scanned files do not match, use the following procedure to do Document Feed Adjustment. If you want to shorten the length of the print out, press the minus button. If you want to lengthen it, press the plus button. Differences in length may occur due to the type of paper used for printing.

1

Press **Menu** on the Home screen.

## Problem Solver

### 2 Touch **General Settings - Scan Settings - Scan Options - Document Feed Adjustment.**

The adjustment value settings screen appears. The adjustment values are shown in %.

### 3 Either touch - or + to show the intended adjustment values or touch the adjustment entry area to enter the adjustment values using the keypad screen.

Adjustment values are determined as shown below.

Example) When the length of the original is 50 cm and the print result is 50.1 cm:  
 $50/50.1 \times 100 - 100 = -0.1996$ , rounded at the second decimal.

Adjustment value: -0.2

### 4 Touch **OK.**

## Image Stitching Adjustment

As for the original ( **A** ) shown in the figure below, if a misalignment occurs in the scanned image, such as in **B** , do Image Stitching Adjustment using the following procedure.

If the original has wrinkles or is an uneven thicknesses, the parts where the images join together may be misaligned even after performing **Image Stitching Adjustment**.

The arrow in **B** indicates the feed direction of the original.

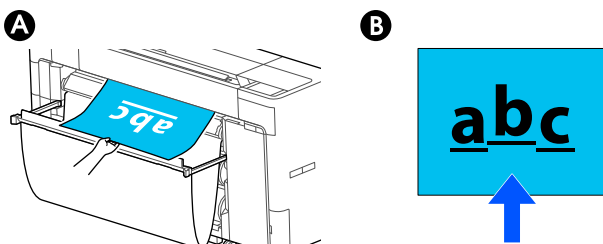

### 1 Touch **Settings** on the Home screen.

### 2 Touch **General Settings - Scan Settings - Scan Options - Image Stitching Adjustment.**

The adjustment value settings screen appears.

### 3 Either touch - or + to show the intended adjustment values or touch the adjustment entry area to enter the adjustment values using the keypad screen.

Shifting the adjustment value by 1 will correct the misalignment by about 0.1 mm in the actual size.

#### **When the Scan Results Are Shifted Up in Relation to the Feed Direction of the Original**

Set the adjustment value toward the plus sign.

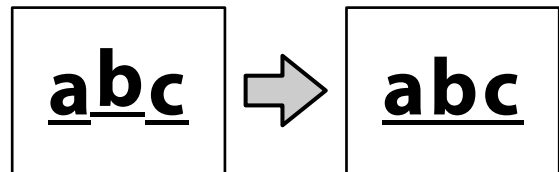

#### **When the Scan Results Are Shifted Down in Relation to the Feed Direction of the Original**

Set the adjustment value toward the minus sign.

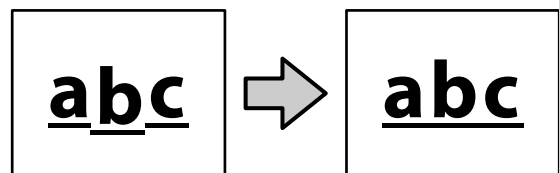

### 4 Touch **OK.**

## The Scanner Slot Has Come Off



## Problem Solver

- **If the scanner slot comes off, open the scanner cover and then install the scanner slot.**

The scanner slot is easier to install if it is inserted from the left.



## Appendix

# Appendix

## Options and Consumable Products

The following options and consumable products are available for use with your printer. (As of August, 2022)

For the latest information, see the Epson Web site.

### Epson Special Media

 [“Epson Special Media Table” on page 220](#)

### Ink Cartridges (Except for the SC-P8500DL Series/SC-T7700DL Series)

Epson recommends the use of genuine Epson ink cartridges. Epson cannot guarantee the quality or reliability of non-genuine ink. The use of non-genuine ink may cause damage that is not covered by Epson's warranties, and under certain circumstances, may cause erratic printer behavior.

Information about non-genuine ink levels may not be displayed, and use of non-genuine ink is recorded for possible use in service support.

 [“Replacing Ink Cartridges \(Except for the SC-P8500DL Series/SC-T7700DL Series\)” on page 177](#)

**SC-P8500DM/SC-P8500D/SC-P8560D/SC-P6500D/SC-P6560D/SC-P6500DE/SC-P6560DE/SC-P6500E/SC-P6560E**

Color Name	Part number	
	700ml	350ml
Photo Black	T48M1	T48U1
Cyan	T48M2	T48U2
Magenta	T48M3	T48U3
Yellow	T48M4	T48U4
Matte Black	T48M8	T48U8
Gray	T48ME	T48UE

## Appendix

### SC-T7700DM/SC-T7700D/SC-T7760DM/SC-T7760D/SC-T5700DM/SC-T5700D/SC-T5760DM/SC-T5760D/ SC-T3700D/SC-T3760D/SC-T3700DE/SC-T3760DE/SC-T3700E/SC-T3760E

Color Name	Part number	
	700ml	350ml
Photo Black	T50M1	T50U1
Cyan	T50M2	T50U2
Magenta	T50M3	T50U3
Yellow	T50M4	T50U4
Matte Black	T50M8	T50U8
Red	T50MF	T50UF

### SC-P8540D/SC-P6540D/SC-P6540DE/SC-P6540E

Color Name	Part number		
	700ml	350ml	110ml
Photo Black	T48Q1	T48X1	T49E1
Cyan	T48Q2	T48X2	T49E2
Magenta	T48Q3	T48X3	T49E3
Yellow	T48Q4	T48X4	T49E4
Matte Black	T48Q8	T48X8	T49E8
Gray	T48QE	T48XE	T49EE

### SC-T7740DM/SC-T7740D/SC-T5740DM/SC-T5740D/SC-T3740D/SC-T3740DE/SC-T3740E

Color Name	Part number		
	700ml	350ml	110ml
Photo Black	T50Q1	T50X1	T51E1
Cyan	T50Q2	T50X2	T51E2
Magenta	T50Q3	T50X3	T51E3
Yellow	T50Q4	T50X4	T51E4
Matte Black	T50Q8	T50X8	T51E8
Red	T50QF	T50XF	T51EF

## Appendix

### SC-P8530DM/SC-P8530D/SC-P6530D/SC-P6530DE/SC-P6530E

Color Name	Part number		
	700ml	350ml	110ml *1
Photo Black	T48R1	T48Y1	T49G1
Cyan	T48R2	T48Y2	T49G2
Magenta	T48R3	T48Y3	T49G3
Yellow	T48R4	T48Y4	T49G4
Matte Black	T48R8	T48Y8	T49G8
Gray	T48RE	T48YE	T49GE

\*1 May not be available depending on the specifications.

### SC-T7730DM/SC-T7730D/SC-T5730DM/SC-T5730D/SC-T3730D/SC-T3730DE/SC-T3730E

Color Name	Part number		
	700ml	350ml	110ml
Photo Black	T50R1	T50Y1	T51F1
Cyan	T50R2	T50Y2	T51F2
Magenta	T50R3	T50Y3	T51F3
Yellow	T50R4	T50Y4	T51F4
Matte Black	T50R8	T50Y8	T51F8
Red	T50RF	T50YF	T51FF

### SC-P8580DM/SC-P8580D/SC-P8590D/SC-P6580D/SC-P6590D/SC-P6580DE/SC-P6590DE/SC-P6580E/SC-P6590E

Color Name	Part number	
	700ml	350ml
Photo Black	T48P1	T48W1
Cyan	T48P2	T48W2
Magenta	T48P3	T48W3
Yellow	T48P4	T48W4
Matte Black	T48P8	T48W8
Gray	T48PE	T48WE

## Appendix

### SC-T7780D/SC-T7790D/SC-T5780DM/SC-T5780D/SC-T5790DM/SC-T5790D/SC-T3780D/SC-T3790D/ SC-T3780DE/SC-T3790DE/SC-T3780E/SC-T3790E

Color Name	Part number	
	700ml	350ml
Photo Black	T50P1	T50W1
Cyan	T50P2	T50W2
Magenta	T50P3	T50W3
Yellow	T50P4	T50W4
Matte Black	T50P8	T50W8
Red	T50PF	T50WF

## Ink Supply Units (SC-P8500DL Series/SC-T7700DL Series)

Epson recommends the use of genuine Epson ink supply units. Epson cannot guarantee the quality or reliability of nongenuine ink. The use of non-genuine ink may cause damage that is not covered by Epson's warranties, and under certain circumstances, may cause erratic printer behavior. Information about non-genuine ink levels may not be displayed, and use of non-genuine ink is recorded for possible use in service support.

### SC-P8500DL/SC-P8560DL

Color Name	Part number
	1600ml
Photo Black	T53F1
Cyan	T53F2
Magenta	T53F3
Yellow	T53F4
Matte Black	T53F8
Gray	T53F7

### SC-T7700DL/SC-T7760DL

Color Name	Part number
	1600ml
Photo Black	T53A1
Cyan	T53A2
Magenta	T53A3
Yellow	T53A4
Matte Black	T53A8

## Appendix

Color Name	Part number
	1600ml
Red	T53A9

### SC-P8540DL

Color Name	Part number
	1600ml
Photo Black	T53H1
Cyan	T53H2
Magenta	T53H3
Yellow	T53H4
Matte Black	T53H8
Gray	T53H7

### SC-T7740DL

Color Name	Part number
	1600ml
Photo Black	T53C1
Cyan	T53C2
Magenta	T53C3
Yellow	T53C4
Matte Black	T53C8
Red	T53C9

### SC-P8530DL





Color Name	Part number
	1600ml
Photo Black	T53J1
Cyan	T53J2
Magenta	T53J3
Yellow	T53J4
Matte Black	T53J8
Gray	T53J7

## Appendix

### SC-T7730DL

Color Name	Part number
	1600ml
Photo Black	T53D1
Cyan	T53D2
Magenta	T53D3
Yellow	T53D4
Matte Black	T53D8
Red	T53D9

## Others

Product	Part number	Explanation
Maintenance Box	C13S210115	Maintenance box for waste ink. This is displayed as Maintenance Box1 on the control panel.  <a href="#">"Replacing the Maintenance Box" on page 181</a>
Borderless Maintenance Box	C13S210116	Maintenance box for borderless printing. This is displayed as Maintenance Box2 on the control panel.  <a href="#">"Replacing the Borderless Maintenance Box" on page 182</a>
Printer Cutter Blade	C13S210117	 <a href="#">"Replacing the auto cutter blade" on page 184</a>
Roll Feed Spindle (44")	C12C936171/C12C936221	The model number depends on your region. Replace the roll paper spindle if it is damaged.
Roll Feed Spindle (36")	C12C937671/C12C937681	
Roll Feed Spindle (24")	C12C937711/C12C937721	
SSD Unit	C12C936671/C12C936681	The model number depends on your region. Optional storage unit. Allows you to save or reprint print jobs.  <a href="#">"Using the SSD Unit (Optional)" on page 79</a>
Production Stacker (44")	C12C937131/C12C937141	Allows you to stack a large amount of printed materials. The model number depends on your region.
Production Stacker (36")	C12C937691/C12C937701	
Production Stacker (24")	C12C937731/C12C937741	

## Appendix

# Supported Media

We recommend you use the following Epson special media for high-quality printing results.

**Note:**

For information about the media types and appropriate settings for printing on paper other than Epson special media or when using raster image processing (RIP) software, see the documentation supplied with the paper, or contact the dealer of the paper or the manufacturer of the RIP.

## Epson Special Media Table

### Roll Paper

The XXX in the ICC profile indicates the model name. Select the name of your model.

Supported paper widths vary depending on the model you are using.

#### **Premium Glossy Photo Paper(250)**

Target Models	All models
Roll core size	3 inches
Paper Type (printer driver)	Premium Glossy Photo Paper(250)
ICC Profile	Epson_XXX_PremiumGlossyPhotoPaper250.icc
Paper Width	406mm/16 inches 610mm/24 inches 914mm/36 inches 1118mm/44 inches

#### **Premium Semigloss Photo Paper(250)**

Target Models	All models
Roll core size	3 inches
Paper Type (printer driver)	Premium Semigloss Photo Paper(250)
ICC Profile	Epson_XXX_PremiumSemiglossPhotoPaper250.icc
Paper Width	406mm/16 inches 610mm/24 inches 914mm/36 inches 1118mm/44 inches

#### **Premium Luster Photo Paper(260)**

Target Models	All models
Roll core size	3 inches
Paper Type (printer driver)	Premium Luster Photo Paper(260)

## Appendix

ICC Profile	Epson_XXX_PremiumLusterPhotoPaper260.icc
Paper Width	406mm/16 inches 610mm/24 inches 914mm/36 inches 1118mm/44 inches

### **Premium Semimatte Photo Paper(260)**

Target Models	All models
Roll core size	3 inches
Paper Type (printer driver)	Premium Semimatte Photo Paper(260)
ICC Profile	Epson_XXX_PremiumSemimattePhotoPaper260.icc
Paper Width	406mm/16 inches 610mm/24 inches 914mm/36 inches 1118mm/44 inches

### **Photo Paper Gloss 250**

Target Models	All models
Roll core size	3 inches
Paper Type (printer driver)	Photo Paper Gloss 250
ICC Profile	Epson_XXX_PhotoPaperGloss250.icc
Paper Width	17 inches 610mm/24 inches 914mm/36 inches 1118mm/44 inches

### **Premium Glossy Photo Paper(170)**

Target Models	All models
Roll core size	2 inches
Paper Type (printer driver)	Premium Glossy Photo Paper(170)
ICC Profile	Epson_XXX_PremiumGlossyPhotoPaper170.icc
Paper Width	420mm(A2) 594mm(A1) 610mm/24 inches 728mm(B1) 914mm/36 inches 1118mm/44 inches

### **Premium Semigloss Photo Paper(170)**

Target Models	All models
Roll core size	2 inches

## Appendix

Paper Type (printer driver)	Premium Semigloss Photo Paper(170)
ICC Profile	Epson_XXX_PremiumSemiglossPhotoPaper170.icc
Paper Width	420mm(A2) 594mm(A1) 610mm/24 inches 728mm(B1) 914mm/36 inches 1118mm/44 inches

### ***Baryta***

Target Models	SC-P Series
Roll core size	2 inches
Paper Type (printer driver)	Baryta
ICC Profile	Epson_XXX_Baryta.icc
Paper Width	17 inches 610mm/24 inches 1118mm/44 inches

### ***Watercolor Paper - Radiant White***

Target Models	SC-P Series
Roll core size	2 inches
Paper Type (printer driver)	Watercolor Paper - Radiant White
ICC Profile	Epson_XXX_WatercolorPaper-RadiantWhite.icc
Paper Width	420mm(A2) 594mm(A1) 610mm/24 inches 728mm(B1) 914mm/36 inches 1118mm/44 inches

### ***UltraSmooth Fine Art paper***

Target Models	SC-P Series
Roll core size	2 inches
Paper Type (printer driver)	UltraSmooth Fine Art paper
ICC Profile	Epson_XXX_UltraSmoothFineArtpaper.icc
Paper Width	420mm(A2) 594mm(A1) 610mm/24 inches 728mm(B1) 914mm/36 inches 1118mm/44 inches

## Appendix

### ***Fine Art Matte***

Target Models	SC-P Series
Roll core size	2 inches
Paper Type (printer driver)	Fine Art Matte
ICC Profile	Epson_XXX_FineArtMatte.icc
Paper Width	420mm(A2) 594mm(A1) 610mm/24 inches 728mm(B1) 914mm/36 inches 1118mm/44 inches

### ***Canvas Matte***

Target Models	All models
Roll core size	2 inches
Paper Type (printer driver)	Canvas Matte
ICC Profile	Epson_XXX_CanvasMatte.icc
Paper Width	420mm(A2) 594mm(A1) 610mm/24 inches 728mm(B1) 914mm/36 inches 1118mm/44 inches

### ***Canvas Satin***

Target Models	All models
Roll core size	2 inches
Paper Type (printer driver)	Canvas Satin
ICC Profile	Epson_XXX_CanvasSatin.icc
Paper Width	420mm(A2) 594mm(A1) 610mm/24 inches 728mm(B1) 914mm/36 inches 1118mm/44 inches

### ***Doubleweight Matte Paper***

Target Models	All models
Roll core size	2 inches
Paper Type (printer driver)	Doubleweight Matte Paper
ICC Profile	Epson_XXX_DoubleweightMattePaper.icc

## Appendix

Paper Width	594mm(A1) 610mm/24 inches 728mm(B1) 914mm/36 inches 1118mm/44 inches
-------------	--

### **Enhanced Matte Paper**

Target Models	All models
Roll core size	2 inches
Paper Type (printer driver)	Enhanced Matte Paper
ICC Profile	Epson_XXX_EnhancedMattePaper.icc
Paper Width	A4 LTR A3 A3+/SuperB A2 US-C

### **Singleweight Matte Paper**

Target Models	All models
Roll core size	2 inches
Paper Type (printer driver)	Singleweight Matte Paper
ICC Profile	Epson_XXX_SingleweightMattePaper.icc
Paper Width	420mm(A2) 17 inches 515mm(B2) 594mm(A1) 610mm/24 inches 728mm(B1) 914mm/36 inches 1118mm/44 inches

### **Plain Paper**

Target Models	All models
Roll core size	2 inches
Paper Type (printer driver)	Plain Paper
ICC Profile	Epson_XXX_GenericPlainPaper.icc

## Appendix

Paper Width	11 inches 420mm(A2) 18 inches 22 inches 594mm(A1) 610mm/24 inches 30 inches 841mm(A0) 34 inches 914mm/36 inches 42 inches
-------------	---

### Plain Paper Thick

Target Models	All models
Roll core size	2 inches
Paper Type (printer driver)	Plain Paper Thick
ICC Profile	Epson_XXX_PlainPaperThick.icc
Paper Width	420mm(A2) 515mm(B2) 594mm(A1) 610mm/24 inches 728mm(B1) 841mm(A0) 914mm/36 inches 1030mm(B0) 1118mm/44 inches

### Plain Paper Thin

Target Models	All models
Roll core size	2 inches
Paper Type (printer driver)	Plain Paper Thin
ICC Profile	Epson_XXX_PlainPaperThin.icc
Paper Width	420mm(A2) 594mm(A1) 841mm(A0) 1030mm(B0)

### Glossy Film2

Target Models	All models
Roll core size	2 inches
Paper Type (printer driver)	Glossy Film 2
ICC Profile	Epson_XXX_GlossyFilm2.icc
Paper Width	610mm/24 inches 914mm/36 inches 1118mm/44 inches

## Appendix

### **Heavy Weight Polyester Banner**

Target Models	All models
Roll core size	2 inches
Paper Type (printer driver)	Heavy Weight Polyester Banner
ICC Profile	Epson_XXX_MCPM Cloth.icc
Paper Width	610mm/24 inches 914mm/36 inches 1118mm/44 inches

### **Enhanced Synthetic Paper**

Target Models	All models
Roll core size	2 inches
Paper Type (printer driver)	Enhanced Synthetic Paper
ICC Profile	Epson_XXX_EnhancedSyntheticPaper.icc
Paper Width	17 inches 610mm/24 inches 914mm/36 inches 1118mm/44 inches

### **Enhanced Adhesive Synthetic Paper**

Target Models	All models
Roll core size	2 inches
Paper Type (printer driver)	Enhanced Adhesive Synthetic Paper
ICC Profile	Epson_XXX_EnhancedAdhesiveSyntheticPaper.icc
Paper Width	610mm/24 inches 914mm/36 inches 1118mm/44 inches

### **Enhanced Low Adhesive Synthetic Paper**

Target Models	All models
Roll core size	2 inches
Paper Type (printer driver)	Enhanced Low Adhesive Synthetic Paper
ICC Profile	Epson_XXX_EnhancedLowAdhesiveSyntheticPaper.icc
Paper Width	610mm/24 inches 914mm/36 inches 1118mm/44 inches

### **Backlight Film Roll**

Target Models	All models
---------------	------------

## Appendix

Roll core size	2 inches
Paper Type (printer driver)	Backlight Film Roll PK
ICC Profile	Epson_XXX_BacklightFilm_PK_BK.icc
Paper Width	610mm/24 inches 914mm/36 inches 1118mm/44 inches

### **Backlight Film Roll**

Target Models	All models
Roll core size	2 inches
Paper Type (printer driver)	Backlight Film Roll MK
ICC Profile	Epson_XXX_BacklightFilm_MK_MB.icc
Paper Width	610mm/24 inches 914mm/36 inches 1118mm/44 inches

### **Cut sheet/Poster board**

The XXX in the ICC profile indicates the model name. Select the name of your model.

Supported paper sizes vary depending on the model you are using.

### **Premium Glossy Photo Paper**

Target Models	All models
Paper Type (printer driver)	Premium Photo Paper Glossy
ICC Profile	Epson_XXX_PremiumGlossyPhotoPaper.icc
Paper Size	A4 LTR 11"x14" A3 A3+/SuperB A2 US-C

### **Premium Photo Paper Semi-gloss**

Target Models	All models
Paper Type (printer driver)	Premium Photo Paper Semi-gloss
ICC Profile	Epson_XXX_PremiumSemiglossPhotoPaper.icc

## Appendix

Paper Size	A4 LTR A3 A3+/SuperB A2 US-C
------------	---

### ***Premium Luster Photo Paper***

Target Models	All models
Paper Type (printer driver)	Premium Luster Photo Paper
ICC Profile	Epson_XXX_PremiumLusterPhotoPaper.icc
Paper Size	A4 LTR A3 A2 US-C

### ***Velvet Fine Art Paper***

Target Models	All models
Paper Type (printer driver)	Velvet Fine Art Paper
ICC Profile	Epson_XXX_VelvetFineArtPaper.icc
Paper Size	A3+ A2

### ***UltraSmooth Fine Art paper***

Target Models	SC-P Series
Paper Type (printer driver)	UltraSmooth Fine Art paper
ICC Profile	Epson_XXX_UltraSmoothFineArtpaper.icc
Paper Size	A3+ A2

### ***Archival Matte Paper***

Target Models	All models
Paper Type (printer driver)	Archival Matte Sheet
ICC Profile	Epson_XXX_ArchivalMattePaper.icc
Paper Size	A4 LTR A3 A3+/SuperB A2 US-C

## Appendix

### Photo Quality Inkjet Paper

Target Models	All models
Paper Type (printer driver)	Photo Quality IJ Paper Sheet
ICC Profile	Epson_XXX_PhotoQualityInkJetPaper.icc
Paper Size	A4 LTR Legal A3 A3+/SuperB A2 US-C

### Enhanced Matte Poster Board

Target Models	All models
Paper Type (printer driver)	Enhanced Matte Poster Board
ICC Profile	Epson_XXX_EnhancedMattePosterBoard.icc
Paper Size	610 mm (24") × 762 mm (30") 762 mm (30") × 1016 mm (40") B2 B1

## Supported Commercially Available Paper

When using commercially available paper, make sure you register the paper information.

 [“Before Printing on Commercially Available Paper” on page 231](#)

This printer supports the following paper specifications for non-Epson media.

#### **Important:**

- Do not use paper that is wrinkled, scuffed, torn, or dirty.
- Although plain paper and recycled paper manufactured by other companies can be loaded and fed in the printer as long as they meet the following specifications, Epson cannot guarantee the print quality.
- Although other paper types manufactured by other companies can be loaded in the printer as long as they meet the following specifications, Epson cannot guarantee the paper feeding and print quality.

### Roll Paper

Supported paper sizes vary depending on the model you are using.

Roll core size	2 or 3 inch
Roll paper outer diameter	Within 170 mm
Paper Width	254 mm (10 inches) to 1,118 mm (44 inches)

## Appendix

Paper Thickness	0.07mm to 0.8mm
-----------------	-----------------

### Cut sheet/Poster board

Supported paper sizes vary depending on the model you are using.

Paper Width	182 mm (B5 width) to 1,118 mm (44 inches)
Paper Length	220 mm to 1600 mm
Paper Thickness	0.07 mm to 0.8 mm (0.8 mm to 1.5 mm for poster board)

## Supported Paper Widths

The following paper widths are supported. You can perform right and left borderless printing on paper sizes that support borderless printing.

Paper Width (Size)		44 inch models		36 inch models		24 inch models	
Inches	mm	Supported	Borderless Printing	Supported	Borderless Printing	Supported	Borderless Printing
44inch	1118mm	Supported	Supported	-	-	-	-
42inch	1067mm	Supported	-	-	-	-	-
	1030mm	Supported	Supported	-	-	-	-
	1000mm	Supported	-	-	-	-	-
36inch	914mm	Supported	Supported	Supported	Supported	-	-
	900mm	Supported	-	Supported	-	-	-
34inch	864mm	Supported	-	Supported	Supported	-	-
ISO A0	841mm	Supported	Supported	Supported	Supported	-	-
	800mm	Supported	-	Supported	-	-	-
30inch	762mm	Supported	-	Supported	-	-	-
JIS B1/B2	728mm	Supported	Supported	Supported	Supported	-	-
F	711mm	-	-	-	-	-	-
ISO B1/B2	707mm	Supported	-	Supported	-	-	-
	700mm	Supported	Supported	Supported	Supported	-	-
27inch	686mm	-	-	-	-	-	-
26inch	660mm	-	-	-	-	-	-
24inch	610mm	Supported	Supported	Supported	Supported	Supported	Supported
	600mm	Supported	-	Supported	-	Supported	-
ISO A1/A2	594mm	Supported	Supported	Supported	Supported	Supported	Supported

## Appendix

Paper Width (Size)		44 inch models		36 inch models		24 inch models	
Inches	mm	Supported	Borderless Printing	Supported	Borderless Printing	Supported	Borderless Printing
22inch	559mm	Supported	-	Supported	-	Supported	-
JIS B2/B3	515mm	Supported	Supported	Supported	Supported	Supported	Supported
20inch	508mm	Supported	Supported	Supported	Supported	Supported	Supported
	500mm	Supported	Supported	Supported	Supported	Supported	Supported
18inch	457mm	Supported	-	Supported	-	Supported	-
	450mm	-	-	-	-	-	-
17inch	432mm	Supported	Supported	Supported	Supported	Supported	Supported
ISO A2/A3	420mm	Supported	-	Supported	-	Supported	-
16inch	406mm	Supported	Supported	Supported	Supported	Supported	Supported
	400mm	Supported	-	Supported	-	Supported	-
JIS B3/B4	364mm	Supported	-	Supported	-	Supported	-
14inch	356mm	Supported	-	Supported	-	Supported	-
ISO B3	353mm	-	-	-	-	-	-
13inch	330mm	Supported	Supported	Supported	Supported	Supported	Supported
12inch	305mm	Supported	-	Supported	-	Supported	-
	300mm	Supported	Supported	Supported	Supported	Supported	Supported
ISO A3/A4	297mm	Supported	-	Supported	-	Supported	-
11inch	279mm	Supported	-	Supported	-	Supported	-
	257mm	Supported	-	Supported	-	Supported	Supported
10inch	254mm	Supported	Supported	Supported	Supported	Supported	Supported
Less than 10 inch	Less than 254mm	-	-	-	-	-	-

## Before Printing on Commercially Available Paper

**Note:**

- Be sure to check the paper characteristics (such as if the paper is glossy, the material, and the thickness) in the manual provided with the paper or contact the dealer of the paper.
- Test the print quality with this printer before purchasing a large amount of paper.

## Appendix

When using paper such as baryta, matte fine art paper, matte canvas, satin canvas, or non-Epson media (commercially available paper), make the paper configuration according to the characteristics of the paper (Custom paper) before printing. Printing without making configuring may cause wrinkles, rubbing, uneven colors, and so on.

Make sure you set the following four items.

<p>Select Reference Paper</p>	<p>The optimum settings for using different types of Epson special media have already been registered to this printer.</p> <p>Check the following, and then select the Epson special media type or general paper settings that are closest to the paper you are using.</p> <p>General paper settings</p> <p>General paper settings have not been optimized for any specific paper type. You can then optimize the settings according to the paper provided by the user.</p> <ul style="list-style-type: none"> <li><input type="checkbox"/> Photo Paper: Baryta</li> <li><input type="checkbox"/> Fine Art Paper: Fine Art Matte</li> <li><input type="checkbox"/> Canvas: satin canvas, matte canvas</li> <li><input type="checkbox"/> Plain paper: Plain paper</li> <li><input type="checkbox"/> Glossy paper: <b>Photo Paper</b></li> <li><input type="checkbox"/> Thick paper that is not glossy: <b>Matte Paper</b></li> <li><input type="checkbox"/> Thin, soft paper that is not glossy; <b>Plain Paper</b></li> <li><input type="checkbox"/> Canvas-like paper: Canvas</li> <li><input type="checkbox"/> Cotton paper with an uneven surface: <b>Fine Art Paper</b></li> <li><input type="checkbox"/> Special media such as film, cloth, poster board, and tracing paper: <b>Others</b></li> </ul>
<p>Paper Thickness</p>	<p>Set the thickness of the paper. If you do not know the paper thickness, check the manual supplied with the paper or the paper supplier.</p> <p>This allows you to reduce the grainy feeling and scuff marks in print outs, as well as differences in the print position and color.</p>
<p>Roll core size</p>	<p>Set the paper core size for the roll paper being loaded.</p>
<p>Paper Feed Offset</p>	<p>Optimizes the paper feed when printing. By adjusting the gap between the data size and the print size, you can reduce the chance of banding (horizontal banding) or uneven colors.</p> <p>Example of entering settings</p> <p>When printing at a data size of 100 mm and a print size of 101 mm, the offset is 1.0%. Therefore, you would enter a value of -1.0%.</p>

 **Important:**

*If you change even one item set in the Paper menu, you need to perform **Paper Feed Offset** again.*

## Appendix

### Make custom paper settings on the control panel

- 1 Select **General Settings - Printer Settings - Custom Paper Setting** on the control panel.

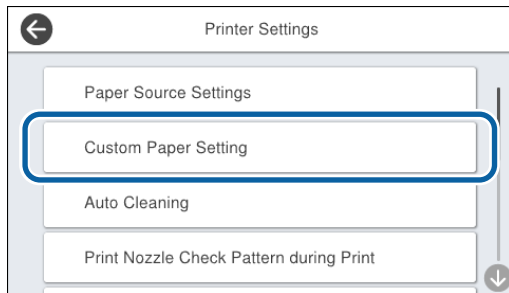

- 2 Select a paper number from 1 to 30 to save the settings.

- 3 Set the paper information.  
Make sure you set the following items.

- Change Reference Paper**
- Paper Thickness**
- Roll Core Diameter** (roll paper only)
- Paper Feed Offset**

See the following for details on the other settings.

[🔗 “General Settings” on page 147](#)

See the following for more details on paper settings.

[🔗 “When the paper type is not displayed on the control panel or in the driver” on page 58](#)

### Moving or Transporting the Printer

This section describes how to move or transport the printer.

## Appendix

### **Caution:**

- ❑ The printer is heavy and should not be carried by one person. When you pack or move the printer, use four or more people when carrying it.
- ❑ When you lift the printer, maintain a natural posture.
- ❑ When you lift the printer, place your hands at the locations indicated in the following illustration.

If you lift the printer while holding other sections, you may be injured. For example, you may drop the printer or your fingers may be pinched when lowering the printer.

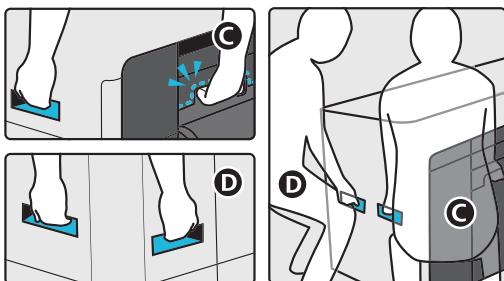
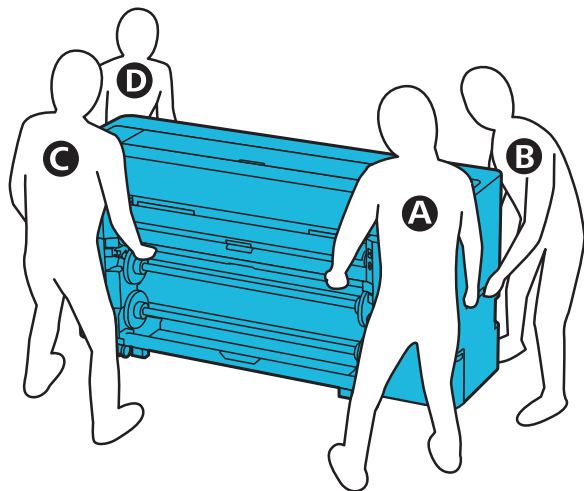
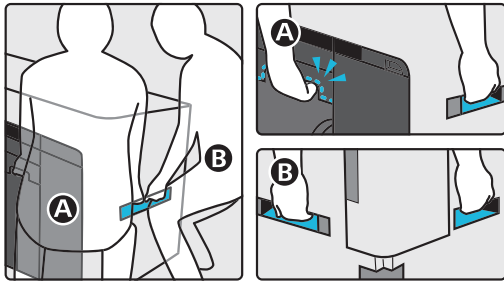

- ❑ Do not tilt the product more than 10 degrees forward or back while moving it. Failure to observe this precaution could cause the product to tip over or ink to leak.

### **Important:**

The print head may be damaged if the environmental temperature falls to  $-10\text{ }^{\circ}\text{C}$  or lower.

If the environmental temperature is expected to be  $-10\text{ }^{\circ}\text{C}$  or lower during movement or transportation, drain the ink before turning off the power.

See the following for more detailed instructions.

 [“If the Environment Indoors or During Transportation Drops to  \$-10\text{ }^{\circ}\text{C}\$  or Lower” on page 236](#)

## Moving to Another Location in the Same Building

### Preparations before moving

This section describes how to move or transport the printer.

It explains how to prepare for a short move, such as to another location in the same building. See the following if you are moving the printer between floors or to another building.

 [“Transporting the Printer” on page 235](#)

If there are no steps or uneven surfaces in the moving path, you can roll the printer on its casters, but note the following points.

### **Caution:**

To prevent accidents such as falling, note the following points when moving the printer.

- ❑ Do not move while the casters are locked.
- ❑ Avoid steps and uneven surfaces.

**1**

Remove all paper from the printer.

**2**

Turn off the printer, and disconnect all cables such as the power cable and LAN cable from the printer.

## Appendix

**3** Close all of the printer's covers.

**4** Unlock the casters.

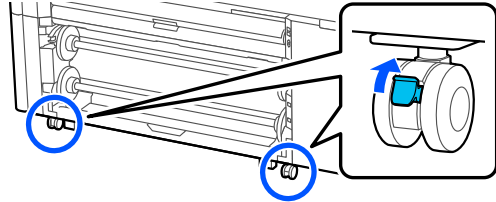

**5** Loosen the stabilizers.

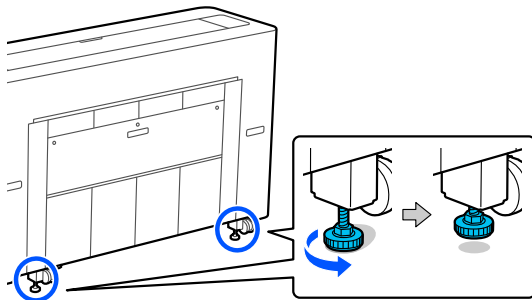

### Operations after moving

This section explains how to prepare the printer for use after moving.

Note the following points when connecting the power cable.

#### **Warning:**

- ❑ To prevent accidents due to electrical leakage, connect to an outlet with a grounded (earthed) connector. Connecting to an outlet other than a grounded outlet may cause electric shock or fire. Check the power outlet you are going to use. If the outlet does not have a grounded connector, contact your dealer.
- ❑ Use only the type of power source indicated on the printer's label. An electric shock or fire could occur.
- ❑ Do not connect the power cable to a power strip or multi plug. An electric shock or fire could occur. Connect the power cable directly to an outlet for domestic use.

**1** Plug the power cable into an outlet with a grounded (earthed) connector, and then turn on the printer.

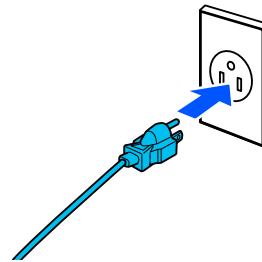

#### **Important:**

*The shape of the power plug varies depending on the country or region. Be sure to use the power cable supplied with the printer.*

**2** Check that the print head nozzles are clear, and if they are clogged, clean the print head.

 [“Print Head Nozzle Check” on page 172](#)

 [“Print Head Cleaning” on page 173](#)

**3** Lock the casters.

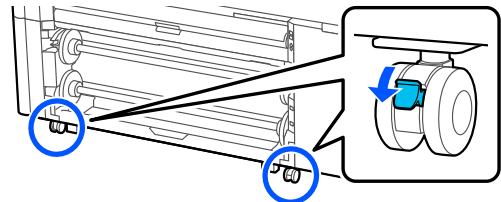

**4** Tighten the stabilizers. Turn the stabilizers by hand until they touch the floor.

Once they touch the floor, do not turn them more than half a turn (180 degrees).

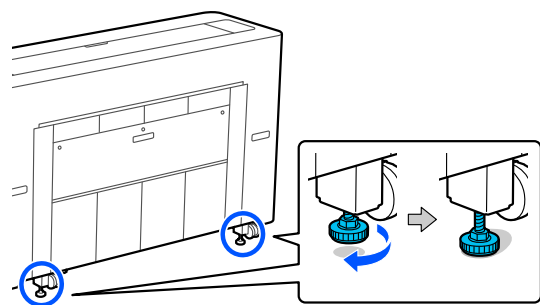

### Transporting the Printer

Before transporting the printer, contact your dealer or Epson Support.



## Appendix

### If the Environment Indoors or During Transportation Drops to -10 °C or Lower

The print head may be damaged if the environmental temperature falls to -10 °C or lower. If the temperature is expected to drop to -10 °C or lower, follow the steps below to drain the ink in advance.

#### **Important:**



*When performing this operation, the discharged ink accumulates in the maintenance box, so make sure there is enough free space in the maintenance box. If there is only a small amount of free space, prepare a replacement maintenance box before starting.*

- 1 Remove all of the paper from the printer.
  -  [“Removing Roll 1/Roll paper” on page 44](#)
  -  [“Removing Roll 2 \(Except for the SC-P6500E Series/SC-T3700E Series\)” on page 48](#)
  -  [“Removing Cut Sheets/Poster Board” on page 56](#)
- 2 Press **Maintenance - Keeping Preparation** from the control panel.
- 3 Press **Start**.  
Ink discharging starts, and the printer turns off automatically when discharging is finished.

#### **Important:**

*Do not open any covers or turn off the printer while discharging ink.*

Next, see the following to prepare for moving or transportation.

-  [“Moving to Another Location in the Same Building” on page 234](#)
-  [“Transporting the Printer” on page 235](#)

#### **Important:**

*If a message is displayed indicating that you need a new XXX ink cartridge when you resume using the printer, prepare an ink cartridge of the color displayed in the XXX section before the next time you use the printer.*

*The next time you turn on the printer, ink will fill the print head nozzles making the printer ready to print; so if you do not have enough ink to fill the nozzles, the printer will not be ready to use until the ink is replaced.*

## Appendix

# System Requirements

Software for this printer can be used in the following environments. (As of August, 2022)  
Supported OS and other elements may change.

For the latest information, see the Epson Web site.

## Printer Driver

### Windows

Operating system	Windows 11 x 64 Windows 10 / Windows 10 x64 Windows 8.1 / Windows 8.1 x64 Windows 8 / Windows 8 x64 Windows 7 / Windows 7 x64 Windows Vista / Windows Vista x64 Windows XP SP3 or later / Windows XP x64 SP2 or later Windows Server 2022 Windows Server 2019 Windows Server 2016 Windows Server 2012 R2 Windows Server 2012 Windows Server 2008 R2 Windows Server 2008 Windows Server 2003 R2 Windows Server 2003 SP2 or later
CPU	Intel Core2 Duo 3.05 GHz or more
Available memory space	1 GB or more
Hard disk (Available volume to install)	32 GB or more
Display resolution	WXGA (1280×800) or better
Connection method with the printer*	USB, Ethernet, or Wi-Fi

\*A wireless LAN connection is not available for models in the SC-T5700D Series that do not have Wi-Fi. For details on the connection methods (interface specifications), see the following.

[🔗 "Specifications Table \(Except for the SC-P8500DL Series/SC-T7700DL Series\)" on page 240](#)

[🔗 "Specifications Table \(SC-P8500DL Series/SC-T7700DL Series Only\)" on page 243](#)

### Mac

Operating system	SC-P8500D Series/SC-T7700D Series: Mac OS X v10.6.8 or later Except for the SC-P8500D Series/SC-T7700D Series: Mac OS X v10.9.5 or later
CPU	Intel Core2 Duo 2 GHz or more
Available memory space	2 GB or more
Hard disk (Available volume to install)	8 GB or more

## Appendix

Display resolution	WXGA+ (1280×800) or better
Connection method with the printer*	USB, Ethernet, or Wi-Fi

\*A wireless LAN connection is not available for models in the SC-T5700D Series that do not have Wi-Fi. For details on the connection methods (interface specifications), see the following.

 [“Specifications Table \(Except for the SC-P8500DL Series/SC-T7700DL Series\)” on page 240](#)

 [“Specifications Table \(SC-P8500DL Series/SC-T7700DL Series Only\)” on page 243](#)

## Appendix

---

### Web Config

Web Config is an application that runs in a web browser on a computer or smart device connected to the same network as the printer.

 *Administrator's Guide*

#### Supported Browsers

Microsoft Edge, Internet Explorer 8 or later, Firefox<sup>\*1</sup>, Chrome<sup>\*1</sup>, Safari<sup>\*1</sup>

\*1 Use the latest version.

See the following for details on the network interfaces.

 [“Specifications Table \(Except for the SC-P8500DL Series/SC-T7700DL Series\)” on page 240](#)

 [“Specifications Table \(SC-P8500DL Series/SC-T7700DL Series Only\)” on page 243](#)

Appendix

# Specifications Table (Except for the SC-P8500DL Series/ SC-T7700DL Series)

Printer Specifications	
Printing method	On-demand inkjet method
Nozzle configuration	
SC-P8500D Series/ SC-P8500DM Series/ SC-6500D Series/ SC-P6500DE Series/ SC-P6500E Series	1600 nozzles x 6 colors (Photo Black, Matte Black, Yellow, Magenta, Cyan, Gray)
SC-T7700D Series/ SC-T7700DM Series/ SC-T5700D Series/ SC-T5700DM Series/ SC-T3700D Series/ SC-T3700DE Series/ SC-T3700E Series	1600 nozzles x 6 colors (Photo Black, Matte Black, Yellow, Magenta, Cyan, Red)
Resolution (maximum)	2400 × 1200 dpi
Control code	
SC-P8500D Series/ SC-P8500DM Series/ SC-P6500D Series/ SC-T7700D Series/ SC-T7700DM Series/ SC-T5700D Series/ SC-T5700DM Series/ SC-T3700D Series	ESC/P raster (undisclosed command), HP-GL/2, HP RTL, Adobe PostScript 3, Adobe PDF 1.7
SC-P6500DE Series/ SC-P6500E Series, SC-T3700DE Series/ SC-T3700E Series	ESC/P raster (undisclosed command), HP-GL/2, HP RTL
Paper feed method	Friction feed
Built-in memory	4 GB
Rated voltage	AC100-240 V
Rated frequency	50/60 Hz
Rated current	3.4-1.6A
Power consumption	

Printer Specifications	
Operating	
SC-P8500D Series/ SC-T7700D Series	Approx. 70W
SC-P8500DM Ser- ies/SC-T7700DM Series/SC-T5700DM Series	Approx. 90W
SC-T5700D Series	Approx. 80W
SC-P6500D Series/ SC-P6500DE Series/ SC-P6500E Series/ SC-T3700D Series/ SC-T3700DE Series/ SC-T3700E Series	Approx. 75W
Ready mode	
Except for the SC-P8500DM Ser- ies/SC-T7700DM Series/SC-T5700DM Series	Approx. 32W
SC-P8500DM Ser- ies/SC-T7700DM Series/SC-T5700DM Series	Approx. 44W
Sleep mode	Approx. 2.0W
Power off	Approx. 0.3W
Temperature	
Operating	10 to 35°C (15 to 25°C is recommended)
In storage (Before un- packing)	-20 to 60 °C (Within 120 hours at 60°C, within a month at 40°C)
In storage (After un- packing)	Ink charged: -10 to 40°C (Within a month at 40°C)  Ink discharged:*1 -20 to 25°C (Within a month at 25°C)
Humidity	
Operating	20 to 80% (40 to 60% is recommended, without condensation)
In storage	5 to 85% (without condensation)

## Appendix

Printer Specifications	
Temperature and humidity range for operating (the range shown by diagonal lines is recommended)	
Dimensions (Width x Depth x Height)	
Maximum (with the paper basket open)	
SC-P8500D Series/ SC-P8500DM Series/ SC-T7700D Series/ SC-T7700DM Series	1848 x 829 x 975 mm
SC-T5700D Series/ SC-T5700DM Series	1645 x 829 x 975 mm
SC-P6500D Series/ SC-P6500DE Series/ SC-P6500E Series/ SC-T3700D Series/ SC-T3700DE Series/ SC-T3700E Series	1365 x 829 x 975 mm
Storage	
SC-P8500D Series/ SC-P8500DM Series/ SC-T7700D Series/ SC-T7700DM Series	1848 x 499 x 975 mm
SC-T5700D Series/ SC-T5700DM Series	1645 x 499 x 975 mm
SC-P6500D Series/ SC-P6500DE Series/ SC-P6500E Series/ SC-T3700D Series/ SC-T3700DE Series/ SC-T3700E Series	1365 x 499 x 975 mm
Weight*2	

Printer Specifications	
SC-P8500D Series/ SC-T7700D Series	Approx. 155 kg
SC-P8500DM Series/ SC-T7700DM Series	Approx. 166 kg
SC-T5700D Series	Approx. 137 kg
SC-T5700DM Series	Approx. 150 kg
SC-P6500D Series/ SC-P6500DE Series/ SC-P6500E Series/ SC-T3700D Series/ SC-T3700DE Series	Approx. 118 kg
SC-T3700E Series	Approx. 115 kg

\*1 Use the **Discharging/Charging Ink** menu in the Maintenance menu to discharge ink from the printer.

"If the Environment Indoors or During Transportation Drops to -10 °C or Lower" on page 236

\*2 Not including ink cartridges.



### Important:

Use the printer at an altitude of 2000 m or less.

Scanner Specifications*1	
Scanner type	Color Simplex Sheet-fed Scanner
Sensor	RGB color filter method CIS
Number of effective pixels	21600 pixels in the main scanning direction (600 dpi)
Original Size	Maximum 914.4 mm x 30480 mm*2 Minimum 148.0 mm x 148.0 mm
Document thickness	0.06 mm to 0.8 mm
Document loading direction	Printable side loaded facing up
Direction of ejection	Scanned side ejected facing up
Number of documents that can be loaded	1
Maximum optical resolution Main scan x Sub scan	600 dpi

## Appendix

Scanner Specifications*1	
Output resolution	200, 300, 400, 600 dpi
Tone	
Color	<input type="checkbox"/> 30 bit input (10 bit input for each RGB color) <input type="checkbox"/> 24 bit output (8 bit output for each RGB color)
Grayscale	<input type="checkbox"/> 10 bit input <input type="checkbox"/> 8 bit output
Black and white	<input type="checkbox"/> 10 bit input <input type="checkbox"/> 1 bit output
Light source	Dual LED (white)

\*1 SC-P8500DM Series/SC-T7700DM Series/SC-T5700DM only

\*2 The maximum length depends on the data format and settings.

 ["Copy \(SC-P8500DM Series/SC-T7700DM Series/SC-T5700DM Series Only\)" on page 129](#)

Interface Specifications	
USB port for a computer	USB 3.2 Gen 1 (Connector: B Type)
USB Memory Port	
USB Flash Memory	Hi-Speed USB (USB Flash Drive with security settings cannot be used.)
File system	FAT, FAT32, exFAT
File format	JPEG, TIFF, some PDFs (See <a href="#">"Printing Files Directly from a USB Flash Drive" on page 114</a> for details on printing PDFs.), HP-GL
Ethernet*1 Standards	IEEE802.3u (100BASE-TX) IEEE802.3ab (1000BASE-T) IEEE 802.3az (supports power-saving models) (The connected device should comply with IEEE802.3az standards.)
Wireless LAN (not available for models that do not have Wi-Fi)	

Interface Specifications	
Standards	
SC-P8500D/ SC-P6500D/ SC-P6500DE/ SC-P6500E SC-T7700D/ SC-T5700D/ SC-T3700D/ SC-T3700DE/ SC-T3700E	IEEE802.11b/g/n
SC-P8530D/ SC-P6530D/ SC-P6530DE/ SC-P6530E SC-T7730D/ SC-T5730D/ SC-T3730D/ SC-T3730DE/ SC-T3730E (except for Taiwan)	
Other than the above (including Taiwan)	IEEE802.11b/g/n/a/ac
Frequency Range	IEEE802.11b/g: 2.4 GHz IEEE802.11n: 2.4 GHz (HT20 only) IEEE 802.11a/n/ac: 5 GHz
Coordination Modes	Infrastructure Wi-Fi Direct (Simple AP) (Not supported for IEEE 802.11b)
Wireless Securities	WEP (64bit/128bit) WPA-PSK (TKIP) WPA2-PSK (AES)*2 WPA3-SAE WPA2-Enterprise (AES) (EAP-TLS/PEAPTLS/PEAPMSCHAPv2/EAP-TTLS) WPA3-Enterprise
Network Printing Protocols/Functions*3	EpsonNet Print (Windows) Standard TCP/IP (Windows) WSD Printing (Windows) Bonjour (Mac) IPP Printing (Windows) IPP Printing (Mac) AirPrint (iOS, Mac)

## Appendix

Interface Specifications	
Security Standards/ Protocols	SSL/TLS (HTTPS Server/Client, IPPS) IEEE802.1X IPsec/IP Filtering SMTPS (STARTTLS, SSL/TLS) SNMPv3 SMB3.1.1

\*1 Use a category 5e or higher STP (shielded twisted pair) cable.

\*2 Complies with WPA2 standards with support for WPA/WPA2 Personal.

\*3 EpsonNet Print supports IPv4 only. The others support both IPv4 and IPv6.

### Warning:

To prevent radio interference to the licensed service, this device is intended to be operated indoors and away from windows to provide maximum shielding. Equipment (or its transmit antenna) that is installed outdoors is subject to licensing.

Ink Specifications	
Type	Dedicated ink cartridges
Ink type	Water-based pigment ink
Use by date	See the expiration date printed on the ink cartridge package or on the cartridge (store at normal temperature)
Print quality guarantee expiry	One year (after installing to the printer)
Storage temperature	
Packed	-20 to 40°C (Within four days at -20°C, within a month at 40°C)
Installed	-10 to 40°C (Within four days at -10°C, within a month at 40°C)
Packed and Transported	-20 to 60°C (Within four days at -20°C, within a month at 40°C, within 72 hours at 60°C)
Cartridge capacity	700 ml, 350 ml, 110 ml (110 ml may not be available depending on the specifications.) 240 ml (for initial charging)

### Important:

- We recommend that you remove and shake the installed ink cartridges once every six months to ensure good print quality.
- The ink freezes if left at below -20 °C for a long time. If it does freeze, leave it at room temperature (25 °C) for at least four hours.
- Do not refill the ink cartridges.

## Specifications Table (SC-P8500DL Series/ SC-T7700DL Series Only)

Printer Specifications	
Printing method	On-demand inkjet method
Nozzle configuration	1600 nozzles x 6 colors SC-P8500DL Series: Photo Black, Matte Black, Yellow, Magenta, Cyan, Gray SC-T7700DL Series: Photo Black, Matte Black, Yellow, Magenta, Cyan, Red
Resolution (maximum)	2400 × 1200 dpi
Control code	ESC/P raster (undisclosed command), HP-GL/2, HP RTL, Adobe PostScript 3, Adobe PDF 1.7
Paper feed method	Friction feed
Built-in memory	4 GB
Rated voltage	AC100-240 V
Rated frequency	50/60 Hz
Rated current	3.4-1.6A
Power consumption	
Operating	Approx. 75 W
Ready mode	Approx. 32 W
Sleep mode	Approx. 2.0 W
Power off	Approx. 0.3 W

## Appendix

Printer Specifications	
Temperature	
Operating	10 to 35°C (15 to 25°C is recommended)
In storage (Before unpacking)	-20 to 60 °C (Within 120 hours at 60°C, within a month at 40°C)
In storage (After unpacking)	Ink charged: -10 to 40°C (Within a month at 40°C) Ink discharged:*1 -20 to 25°C (Within a month at 25°C)
Humidity	
Operating	20 to 80% (40 to 60% is recommended, without condensation)
In storage	5 to 85% (without condensation)
Temperature and humidity range for operating (the range shown by diagonal lines is recommended)	
Dimensions (Width x Depth x Height)	
Maximum dimensions*2	1848 x 829 x 975 mm
Storage	1848 x 499 x 975 mm
Weight*3	Approx. 165 kg

\*1 Use the **Discharging/Charging Ink** menu in the Maintenance menu to discharge ink from the printer.

[“If the Environment Indoors or During Transportation Drops to -10 °C or Lower” on page 236](#)

\*2 With the paper basket open

\*3 Not including the ink supply unit



### Important:

Use the printer at an altitude of 2000 m or less.

Interface Specifications	
USB port for a computer	USB 3.2 Gen 1 (Connector: B Type)
USB Memory Port	
USB Flash Memory	Hi-Speed USB (USB Flash Drive with security settings cannot be used.)
File system	FAT, FAT32, exFAT
File format	JPEG, TIFF, HP-GL, some PDFs (See <a href="#">“Printing Files Directly from a USB Flash Drive” on page 114</a> for details on printing PDFs.)
Ethernet*1 Standards	IEEE802.3u (100BASE-TX) IEEE802.3ab (1000BASE-T) IEEE 802.3az (supports power-saving models) (The connected device should comply with IEEE802.3az standards.)
Wi-Fi	
Standards	
SC-P8500DL/ SC-P8530DL/ SC-T7700DL/ SC-T7730DL (except for Taiwan)	IEEE802.11b/g/n
Other than the above (including Taiwan)	IEEE802.11b/g/n/a/ac

## Appendix

Interface Specifications	
Frequency Range	IEEE802.11b/g: 2.4 GHz IEEE802.11n: 2.4 GHz (HT20 only) IEEE 802.11a/n/ac: 5 GHz
Coordination Modes	Infrastructure Wi-Fi Direct (simple AP) (Not supported for IEEE 802.11b)
Wireless Securities	WEP (64bit/128bit) WPA-PSK (TKIP) WPA2-PSK (AES)*2 WPA3-SAE WPA2-Enterprise (AES) (EAP-TLS/ PEAPTLS/PEAPMSCHAPv2/ EAP-TTLS) WPA3-Enterprise
Network Printing Protocols/Functions*3	EpsonNet Print (Windows) Standard TCP/IP (Windows) WSD Printing (Windows) Bonjour (Mac) IPP Printing (Windows) IPP Printing (Mac) AirPrint (iOS, Mac)
Security Standards/Protocols	SSL/TLS (HTTPS Server/Client, IPPS) IEEE802.1X IPsec/IP Filtering SMTPS (STARTTLS, SSL/TLS) SNMPv3 SMB3.1.1

- \*1 Use a shielded twisted-pair cable (Category 5e or higher).
- \*2 Complies with WPA2 standards with support for WPA/WPA2 Personal.
- \*3 EpsonNet Print supports IPv4 only. The others support both IPv4 and IPv6.

 **Warning:**

To prevent radio interference to the licensed service, this device is intended to be operated indoors and away from windows to provide maximum shielding. Equipment (or its transmit antenna) that is installed outdoors is subject to licensing.

Ink Specifications	
Type	Dedicated ink supply unit
Ink type	Water-based pigment ink
Use by date	See the expiration date printed on the ink supply unit package or on the unit itself (store at normal temperature)
Print quality guarantee expiry	One year (after installing to the printer)
Storage temperature	
Packed	-20 to 40°C (Within four days at -20°C, within a month at 40°C)
Installed	-20 to 40°C (Within four days at -20°C, within a month at 40°C)
Packed and Transported	-20 to 60°C (Within four days at -20°C, within a month at 40°C, within 72 hours at 60°C)
Capacity	1600 ml

 **Important:**

The ink freezes if left at below -20 °C for a long time. If it does freeze, leave it at room temperature (25 °C) for at least four hours.

### For European users

#### Radio Equipment Information

This product intentionally emit radio wave described as follows.

- (a) frequency band in which the radio equipment operates; 2.4 to 2.4835 GHz
- (b) maximum radio-frequency power transmitted in the frequency band in which the radio equipment operates; 20dBm (eirp power)



### For users in Zambia

See the following website to check the information for ZICTA Type Approval.

<https://support.epson.net/zicta/>

## Appendix

### For users in Malaysia

Frequency Band: 2400-2483.5 MHz

## Where To Get Help

---

# Where To Get Help

---

## Technical Support Web Site

Epson's Technical Support Web Site provides help with problems that cannot be solved using the troubleshooting information in your product documentation. If you have a Web browser and can connect to the Internet, access the site at:

<https://support.epson.net/>

If you need the latest drivers, FAQs, manuals, or other downloadables, access the site at:

<https://www.epson.com>

Then, select the support section of your local Epson Web site.

## Contacting Epson Support

---

### Before Contacting Epson

If your Epson product is not operating properly and you cannot solve the problem using the troubleshooting information in your product documentation, contact Epson support services for assistance. If Epson support for your area is not listed below, contact the dealer where you purchased your product.

Epson support will be able to help you much more quickly if you give them the following information:

- Product serial number  
(The serial number label is usually on the back of the product.)
- Product model
- Product software version  
(Click **About**, **Version Info**, or similar button in the product software.)
- Brand and model of your computer
- Your computer operating system name and version
- Names and versions of the software applications you normally use with your product

---

### Help for Users in North America

Epson provides the technical support services listed below.

#### Internet Support

Visit Epson's support website at <https://epson.com/support> and select your product for solutions to common problems. You can download drivers and documentation, get FAQs and troubleshooting advice, or e-mail Epson with your questions.

## Where To Get Help

### Speak to a Support Representative

Dial: (562) 276-1300 (U.S.), or (905) 709-9475 (Canada), 6 am to 6 pm, Pacific Time, Monday through Friday. Days and hours of support are subject to change without notice. Toll or long distance charges may apply.

Before you call Epson for support, please have the following information ready:

- Product name
- Product serial number
- Proof of purchase (such as a store receipt) and date of purchase
- Computer configuration
- Description of the problem

**Note:**

For help using any other software on your system, see the documentation for that software for technical support information.

### Purchase Supplies and Accessories

You can purchase genuine Epson ink cartridges, ribbon cartridges, paper, and accessories from an Epson authorized reseller. To find the nearest reseller, call 800-GO-EPSON (800-463-7766). Or you can purchase online at <http://www.epsonstore.com> (U.S. sales) or <http://www.epson.ca> (Canadian sales).

### Help for Users in Europe

Check your **Pan-European Warranty Document** for information on how to contact Epson support.

### Help for Users in Taiwan

#### Technical Support Web Site

If you need the latest drivers, FAQs, manuals, or videos, please visit Epson's support website at <https://www.epson.com.tw/CustomerAndDownload>

And, select your product.

### Help for Users in Australia/New Zealand

Epson Australia/New Zealand wishes to provide you with a high level of customer service. In addition to your product documentation, we provide the following sources for obtaining information:

#### Your Dealer

Don't forget that your dealer can often help identify and resolve problems. The dealer should always be the first call for advice on problems; they can often solve problems quickly and easily as well as give advice on the next step to take.

#### Internet URL

**Australia**

<https://www.epson.com.au>

**New Zealand**

<https://www.epson.co.nz>

Access the Epson Australia/New Zealand World Wide Web pages.

The site provides a download area for drivers, Epson contact points, new product information and technical support (e-mail).

#### Epson Helpdesk

Epson Helpdesk is provided as a final backup to make sure our clients have access to advice. Operators on the Helpdesk can aid you in installing, configuring and operating your Epson product. Our Pre-sales Helpdesk staff can provide literature on new Epson products and advise where the nearest dealer or service agent is located. Many types of queries are answered here.

The Helpdesk numbers are:

Australia	Phone:	1300 361 054
	Fax:	(02) 8899 3789
New Zealand	Phone:	0800 237 766

## Where To Get Help

We encourage you to have all the relevant information on hand when you ring. The more information you prepare, the faster we can help solve the problem. This information includes your Epson product documentation, type of computer, operating system, application programs, and any information you feel is required.

---

### Help for Users in Singapore

Sources of information, support, and services available from Epson Singapore are:

#### World Wide Web

(<https://www.epson.com.sg>)

Information on product specifications, drivers for download, Frequently Asked Questions (FAQ), Sales Enquiries, and Technical Support via e-mail are available.

#### Epson HelpDesk

**Toll Free: 800-120-5564**

Our HelpDesk team can help you with the following over the phone:

- Sales enquiries and product information
- Product usage questions or problems
- Enquiries on repair service and warranty

---

### Help for Users in Thailand

Contacts for information, support, and services are:

#### World Wide Web

(<https://www.epson.co.th>)

Information on product specifications, drivers for download, Frequently Asked Questions (FAQ), and e-mail are available.

#### Epson Hotline

**(Phone: (66)2460-9699)**

Our Hotline team can help you with the following over the phone:

- Sales enquiries and product information
- Product usage questions or problems
- Enquiries on repair service and warranty

---

### Help for Users in Vietnam

Contacts for information, support, and services are:

Epson Hotline (Phone): +84 28 3925 5545

Service Center: 68 Nam Ky Khoi Nghia  
Street, Nguyen Thai Binh  
Ward,  
District 1, Ho Chi Minh  
City  
Vietnam

---

### Help for Users in Indonesia

Contacts for information, support, and services are:

#### World Wide Web

(<https://www.epson.co.id>)

- Information on product specifications, drivers for download
- Frequently Asked Questions (FAQ), Sales Enquiries, questions through e-mail

#### Epson Hotline

- Sales enquiries and product information
- Technical support
 

Phone	(62) 21-572 4350
Fax	(62) 21-572 4357

#### Epson Service Center

Jakarta      Mangga Dua Mall 3rd floor No 3A/B  
Jl. Arteri Mangga Dua,  
Jakarta

Phone/Fax: (62) 21-62301104

## Where To Get Help

Bandung	Lippo Center 8th floor Jl. Gatot Subroto No.2 Bandung  Phone/Fax: (62) 22-7303766
Surabaya	Hitech Mall It IIB No. 12 Jl. Kusuma Bangsa 116 – 118 Surabaya  Phone: (62) 31-5355035 Fax: (62)31-5477837
Yogyakarta	Hotel Natour Garuda Jl. Malioboro No. 60 Yogyakarta  Phone: (62) 274-565478
Medan	Wisma HSBC 4th floor Jl. Diponegoro No. 11 Medan  Phone/Fax: (62) 61-4516173
Makassar	MTC Karebosi Lt. Ill Kav. P7-8 Jl. Ahmad Yani No.49 Makassar  Phone: (62)411-350147/411-350148

---

## Help for Users in Hong Kong

To obtain technical support as well as other after-sales services, users are welcome to contact Epson Hong Kong Limited.

### Internet Home Page

Epson Hong Kong has established a local home page in both Chinese and English on the Internet to provide users with the following information:

- Product information
- Answers to Frequently Asked Questions (FAQs)
- Latest versions of Epson product drivers

Users can access our World Wide Web home page at:

<https://www.epson.com.hk>

## Technical Support Hotline

You can also contact our technical staff at the following telephone and fax numbers:

Phone: (852) 2827-8911

Fax: (852) 2827-4383

---

## Help for Users in Malaysia

Contacts for information, support, and services are:

### World Wide Web

<https://www.epson.com.my>

- Information on product specifications, drivers for download
- Frequently Asked Questions (FAQ), Sales Enquiries, questions through e-mail

## Epson Trading (M) Sdn. Bhd.

Head Office.

Phone: 603-56288288

Fax: 603-56288388/399

### Epson Helpdesk

- Sales enquiries and product information (Infoline)  
Phone: 603-56288222
- Enquiries on repair services & warranty, product usage and technical support (Techline)  
Phone: 603-56288333

---

## Help for Users in India

Contacts for information, support, and services are:

## Where To Get Help

### World Wide Web

(<https://www.epson.co.in>)

Information on product specifications, drivers for download, and products enquiry are available.

### Helpline

For Service, Product info or to order consumables - 18004250011 (9AM - 6PM) - This is a Toll-free number.

For Service (CDMA & Mobile Users) - 3900 1600 (9AM - 6PM) Prefix local STD code

---

## Help for Users in the Philippines

To obtain technical support as well as other after sales services, users are welcome to contact the Epson Philippines Corporation at the telephone and fax numbers and e-mail address below:

Trunk Line: (63-2) 706 2609

Fax: (63-2) 706 2665

Helpdesk  
Direct Line: (63-2) 706 2625

E-mail: [epchelpdesk@epc.epson.com.ph](mailto:epchelpdesk@epc.epson.com.ph)

### World Wide Web

(<https://www.epson.com.ph>)

Information on product specifications, drivers for download, Frequently Asked Questions (FAQ), and E-mail Inquiries are available.

### Toll-Free No. 1800-1069-EPSON(37766)

Our Hotline team can help you with the following over the phone:

- Sales enquiries and product information
- Product usage questions or problems
- Enquiries on repair service and warranty