



Questo manuale d'istruzione è fornito da trovaprezzi.it. Scopri tutte le offerte per [Intel Server System M50CYP1UR204](#) o cerca il tuo prodotto tra le [migliori offerte di Server](#)



Questo manuale d'istruzione è fornito da trovaprezzi.it. Scopri tutte le offerte per [Intel Server System M50CYP1UR204](#) o cerca il tuo prodotto tra le [migliori offerte di Server](#)



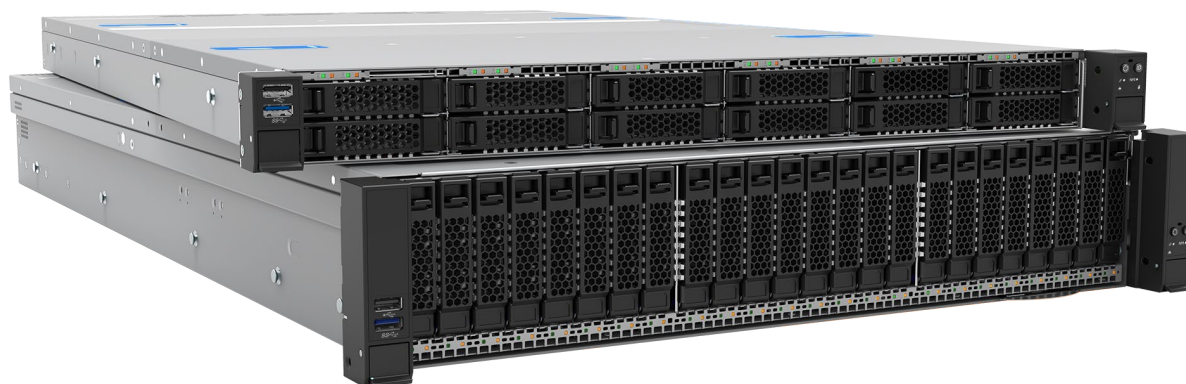
# Intel® Server M50CYP Family

## *Configuration Guide*

A reference document to identify available Intel server building blocks, integrated systems, accessories, and spare parts associated with the Intel® Server M50CYP Family.

Rev. 1.11

March 2023



# M50CYP

**Delivering Breakthrough Data Center System Innovation – Experience What's Inside!**

<This page is intentionally left blank>

## Document Revision History

Date	Revision	Changes
May 2021	1.0	Initial production release.
May 2021	1.1	<ul style="list-style-type: none"> <li>• Tables 10, 11, 12, and 13. Updated packaged gross wt. and un-packaged net wt.</li> <li>• Table 18. Updated Description column for iPC CYPCBLSL204KIT</li> <li>• Chapter 6. Updated 2U GPGPU air duct image</li> <li>• Chapter 7. Updated 2U Tall air duct and 2U Tall air duct images</li> <li>• Tables 37 and 38. Updated tables.</li> <li>• Minor updates throughout for clarity</li> </ul>
June 2021	1.2	<ul style="list-style-type: none"> <li>• Tables 10, 11, 12, 13. Updated "Optional Accessories (sold separately)" column</li> <li>• Table 26. Updated 5th column</li> <li>• Table 35. Updated 1600 W and 2100 W PSUs</li> <li>• Minor updates throughout for clarity</li> </ul>
June 2021	1.3	<ul style="list-style-type: none"> <li>• Table 4, 5, 6. Updated tables</li> <li>• Table 20. Updated 4th column</li> </ul>
July 2021	1.4	<ul style="list-style-type: none"> <li>• Tables 2, 3, 4, 5, 6. Updated tables</li> <li>• Section 1.1.1. Updated section to move M SKU from Supported to Not Supported SKU.</li> <li>• Section 1.1.3. Updated 8th bullet.</li> <li>• Tables 10 and 11. For the "Included" column, updated heat sink reference number from "iPN" to "IPC".</li> <li>• Figures 20 and 21. Updated figures.</li> <li>• Removed "Intel® Integrated RAID Module RMSP3 Product Family" section</li> <li>• Tables 18, 19, 20, 21, 22, 24, 25, 26. Updated tables</li> </ul>
August 2021	1.5	<ul style="list-style-type: none"> <li>• Table 18. Added row on iPC CYPCBLSLHDKIT</li> <li>• Tables 19, 20, 21, 22, 24. Updated tables.</li> <li>• Section 5.3.1, "Intel® Integrated RAID Module RMSP3 Product Family". Added section</li> </ul>
September 2021	1.6	<ul style="list-style-type: none"> <li>• Table 18. Added the cable kits in the last four rows</li> <li>• Table 19. Updated second and third columns.</li> <li>• Table 38. Updated Description column for 1U EVAC Heat Sink</li> <li>• Table 39. Updated Description column for 2U Tall Air Duct row</li> </ul>
January 2022	1.7	<ul style="list-style-type: none"> <li>• Table 18. Added CYPCBLSLHDKIT cable kit</li> <li>• Table 18. Corrected MM# of CYPASMODINT</li> <li>• Table 18. Corrected image and description for CYPCBLSLSSRIS</li> <li>• Table 29. Added E810CQDA1OCPV3, E810XXVDA4OCPV3, X710DA2OCPV3, and X710T4LOCPV3 cards</li> <li>• Table 30 and 31. Updated Description for all Storage and RAID controllers</li> <li>• Corrected Details and Description for CYPCBLINTSTKIT</li> </ul>

## Intel® Server M50CYP Family Configuration Guide

Date	Revision	Changes
March 2022	1.8	<ul style="list-style-type: none"> <li>• Table 18. Added AXXCBLHDHD1150 cable kit.</li> <li>• Table 36. Added CYPCLHDINTST RAID controller to Internal SSD drives kit.</li> <li>• Table 18. Corrected image for CYPCLSLMIDPIN</li> <li>• Table 24. Corrected SAS/SATA 4 or 8-port 12Gb SAS RAID PCIe* Add-in Card→ 12 Gb SAS Expander→ Backplane (BP)</li> <li>• Corrected section 4.5.2 M50CYP2UR 16 x 2.5" / SATA / NVMe Data Cable Guide</li> <li>• Corrected section 4.5.3 M50CYP2UR 16 x 2.5" / SATA / NVMe Data Cable Guide</li> <li>• Corrected MM# 99A5A4# to 99A5A4</li> <li>• Figure 2, "3rd Gen Intel® Xeon® Scalable Processor Identification". Updated figure.</li> <li>• Minor updates throughout for clarity.</li> </ul>
June 2022	1.9	<ul style="list-style-type: none"> <li>• Table 10, 11, 12 and 13 have been updated to explicit all riser cards are separately sold.</li> <li>• Table 18. CYPCLSLHDKIT appeared twice.</li> <li>• Table 27. Corrected port's locations for CYPRISER3RTM</li> <li>• Table 28. Corrected port's locations for CYPRISER3RTM</li> <li>• Table 28. Adding new risers, CYP2URISER1SNL and CYP2URISER2SNL</li> <li>• Table 30. Update description on RMSP3JD160J, RMSP3HD080E, RMSP3AD160F and RMSP3CD080F</li> <li>• Table 31. Update description on RSP3QD160J, RSP3GD016J, RSP3WD080E, RSP3TD160F, RSP3MD088F</li> <li>• Table 32. Update description on RS3P4MF088F</li> <li>• Corrected 2100W PSU MM# from 999D4L to 99C4MW</li> </ul>
November 2022	1.10	<ul style="list-style-type: none"> <li>• Table 39. Update               <ul style="list-style-type: none"> <li>○ Discontinued Trusted Platform Module (TPM) accessory kit – MM# AXXTPMENC8</li> <li>○ Added new Trusted Platform Module (TPM) accessory kit – MM# AXXTPMENC9</li> </ul> </li> </ul>
March 2023	1.11	<ul style="list-style-type: none"> <li>• Table 18. Updating cable's description as follow:               <ul style="list-style-type: none"> <li>○ Changing iPC CYPCLSLAIC2RV to CYPCLSLAIC2RVL</li> <li>○ Changing MM# 99AMXW to MM# 99C79H</li> <li>○ Changing cable's length from 420mm and 550mm to 720mm and 820mm respectively</li> </ul> </li> <li>• Table 39. Update               <ul style="list-style-type: none"> <li>○ Updating MM# for Trusted Platform Module (TPM) accessory kit – AXXTPMENC9</li> </ul> </li> </ul>

## Disclaimers

Intel technologies' features and benefits depend on system configuration and may require enabled hardware, software, or service activation. Performance varies depending on system configuration. No computer system can be absolutely secure. Check with your system manufacturer or retailer or learn more at [intel.com](http://intel.com).

You may not use or facilitate the use of this document in connection with any infringement or other legal analysis concerning Intel products described herein. You agree to grant Intel a non-exclusive, royalty-free license to any patent claim thereafter drafted which includes subject matter disclosed herein.

No license (express or implied, by estoppel or otherwise) to any intellectual property rights is granted by this document.

The products described may contain design defects or errors known as errata, which may cause the product to deviate from published specifications. Current characterized errata are available on request.

Intel disclaims all express and implied warranties, including without limitation, the implied warranties of merchantability, fitness for a particular purpose, and non-infringement, as well as any warranty arising from course of performance, course of dealing, or usage in trade.

This document contains information on products, services and/or processes in development. All information provided here is subject to change without notice. Contact your Intel representative to obtain the latest Intel product specifications.

Copies of documents that have an order number and are referenced in this document may be obtained by calling 1-800-548-4725 or by visiting [www.intel.com/design/literature.htm](http://www.intel.com/design/literature.htm).

Intel, Intel Optane, Xeon, and the Intel logo are trademarks of Intel Corporation or its subsidiaries in the U.S. and/or other countries.

\*Other names and brands may be claimed as the property of others.

© Intel Corporation

## Table of Contents

<b>1. Overview</b>	<b>12</b>
1.1 Configuration Overview	12
1.1.1 Processor Support	13
1.1.2 Memory Support	15
1.1.3 System Configuration Notes	15
1.2 Reference Documents and Support Collaterals	17
1.3 Intel® Server Board M50CYP2SB Options	19
1.4 Intel® Server System M50CYP1UR	25
1.5 Intel® Server System M50CYP2UR	30
1.6 Available Server Board, Chassis, and System SKU Summary	36
<b>2. Server Board Options</b>	<b>37</b>
2.1 Intel® Server Board M50CYP2SB Options	38
<b>3. Server System Configurations</b>	<b>39</b>
3.1 Intel® Server System M50CYP1UR – (1U Rack Mount System)	40
3.2 Intel® Server System M50CYP2UR – (2U Rack Mount System)	43
<b>4. SAS / SATA / NVMe* Data Cable Guide</b>	<b>46</b>
4.1 Data Cable Connector Types	48
4.2 1U / 2U Server System SAS / SATA / NVMe* Cable Kits	49
4.2.1 Cable Kit Product Code Decoder Examples	50
4.2.2 Cable Kit Order Information	51
4.2.3 Cable Recommendations	57
4.3 1U 4 x 2.5" – M50CYP1UR204 SAS / SATA / NVMe* Data Cable Guide	58
4.4 1U 12 x 2.5" – M50CYP1UR212 SAS / SATA / NVMe* Data Cable Guide	60
4.5 2U 2.5" Front Mount Drive Bay Cable Guide	62
4.5.1 M50CYP2UR208 SAS / SATA / NVMe* Data Cable Guide for up to 8 Front Drive Bays	62
4.5.2 Intel® Server System M50CYP2UR 16 x 2.5" SAS / SATA / NVMe* Data Cable Guide	64
4.5.3 Intel® Server System M50CYP2UR 24 x 2.5" SAS / SATA / NVMe* Data Cable Guide	69
4.6 2U 12 x 3.5" – M50CYP2UR312 SAS / SATA / NVMe* Data Cable Guide	73
<b>5. 1U / 2U System Optional Accessories</b>	<b>75</b>

## Intel® Server M50CYP Family Configuration Guide

5.1	1U / 2U PCIe* Riser Card Accessory / Spare FRU Options.....	75
5.1.1	1U Riser Card Options.....	75
5.1.2	2U Riser Card Options.....	77
5.2	Intel® Ethernet Network Adapters for OCP*.....	80
5.3	Intel® RAID Add-in Cards, Modules, and Accessories .....	85
5.3.1	Intel® Integrated RAID Module RMSP3 Product Family .....	85
5.3.2	Intel® RAID Controller Add-in Cards.....	87
5.3.3	Intel® VROC Keys .....	89
5.3.4	Miscellaneous Intel® RAID Accessory Options.....	91
5.4	Power Supply Unit Options and Power Cable Kits .....	92
5.5	1U / 2U Rack Mount Kits .....	95
<b>6.</b>	<b>1U / 2U Miscellaneous Accessory Options.....</b>	<b>97</b>
<b>7.</b>	<b>1U / 2U Spare and Replacement Parts (FRUs) .....</b>	<b>101</b>
<b>Appendix A.</b>	<b>Glossary .....</b>	<b>106</b>

## List of Figures

Figure 1. Intel® Server M50CYP Family Overview.....	12
Figure 2. 3 <sup>rd</sup> Gen Intel® Xeon® Scalable Processor Identification.....	13
Figure 3. Intel® Server Board M50CYP2SB1U Component / Feature Identification .....	19
Figure 4. Intel® Server Board M50CYP2SBSTD Component / Feature Identification.....	20
Figure 5. Server System Components Overview.....	25
Figure 6. 4 x 2.5" front Drive Bay Configuration – M50CYP1UR204.....	25
Figure 7. 12 x 2.5" front Drive Bay Configuration – M50CYP1UR212 .....	26
Figure 8. Back Panel Feature Identification.....	26
Figure 9. Intel® Server System M50CYP2UR Feature Set Identification.....	30
Figure 10. 2U 8 x 2.5" Front Drive Bay Configuration – M50CYP2UR208 .....	30
Figure 11. 2U 16 x 2.5" Front Drive Bay Configuration (based on M50CYP2UR208).....	31
Figure 12. 2U 24 x 2.5" Front Drive Bay Configuration (based on M50CYP2UR208).....	31
Figure 13. 2U 12 x 3.5" Front Drive Bay Configuration – M50CYP2UR312 .....	31
Figure 14. 2U Back Panel Feature Identification.....	32
Figure 15. Illustration of Building Block Options.....	37
Figure 16. Intel® Server System M50CYP1UR Options .....	39
Figure 17. Intel® Server System M50CYP2UR Options .....	39
Figure 18. 2U 8 x 2.5" SAS / SATA / NVMe* Hot-Swap Backplane – Back Side .....	46
Figure 19. 2U 12 x 3.5" HSBP Connector Identification – Back Side .....	47
Figure 20. 1U 4 x 2.5" SAS / SATA / NVMe* Hot Swap Backplane – Back Side .....	47
Figure 21. 1U 12 x 2.5" SAS / SATA / NVMe* Hot Swap Backplane – Back Side .....	47
Figure 22. 4 x 2.5" Front Drive Bay Configuration – M50CYP1UR204.....	58
Figure 23. 12 x 2.5" Front Drive Bay Configuration – M50CYP1UR212 .....	60
Figure 24. 2U 8 x 2.5" Front Drive Bay Configuration – M50CYP2UR208.....	62
Figure 25. 2U 16 x 2.5" Front Drive Bay Configuration .....	65
Figure 26. SAS Expander RES3TV360 Port Mapping.....	67
Figure 27. 2U 24 x 2.5" M50CYP2UR208 Front Drive Bay Configuration.....	69
Figure 28. 2U 2.5" x 24 System HSBP Enumeration.....	69
Figure 29. 2U 12 x 3.5" M50CYP2UR312 Front Drive Bay Configuration .....	73

Figure 30. Intel® Ethernet Network Adapter Placement ..... 80

Figure 31. OCP\* Module Bay Filler Removal (2U System Shown) ..... 81

Figure 32. OCP\* Module with Pull tab Installation (2U System Shown) ..... 81

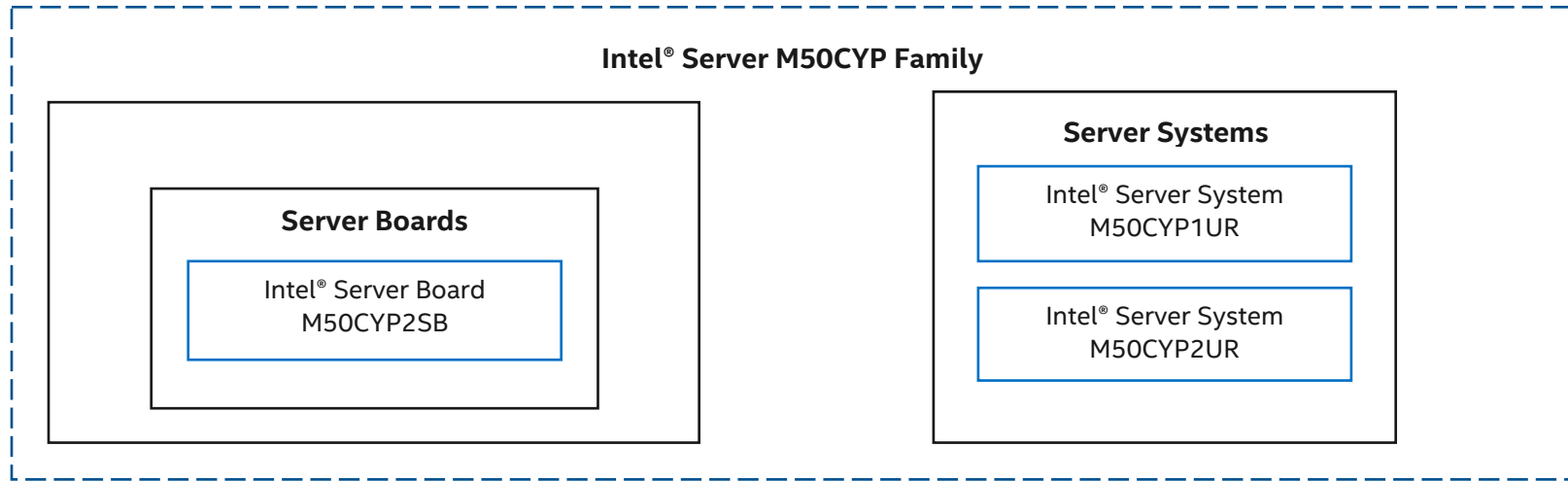
## List of Tables

Table 1. 3 <sup>rd</sup> Gen Intel® Xeon® Scalable Processor Family Feature Comparison .....	14
Table 2. DDR4 DIMM Attributes Table for “Identical” and “Like” DIMMs .....	16
Table 3. Product Family Reference Collaterals.....	17
Table 4. Intel® Server Board M50CYP2SB Features .....	21
Table 5. Intel® Server System M50CYP1UR Features.....	26
Table 6. Intel® Server System M50CYP2UR Features.....	32
Table 7. Server Board (L3) Family Summary .....	36
Table 8. Server System (L6 BIK) Family Summary .....	36
Table 9. Intel® Server Board M50CYP2SB Options.....	38
Table 10. Intel® Server System M50CYP1UR204 product Specifications and Configuration Requirements ....	41
Table 11. Intel® Server System M50CYP1UR212 Specifications and Configuration Requirements.....	42
Table 12. Intel® Server System M50CYP2UR208 Specifications and Configuration Requirements.....	44
Table 13. Intel® Server System M50CYP2UR312 Specifications and Configuration Requirements.....	45
Table 14. Multiport Mini-SAS HD Cable Connectors .....	48
Table 15. x4 PCIe* SlimSAS Cable Connectors .....	48
Table 16. x8 PCIe* SlimSAS Cable Connectors .....	48
Table 17. Data Cable Connector Identification.....	49
Table 18. SAS/SATA/NVMe* Data Cable Kit Description and Order Information.....	51
Table 19. Data Cable Guide for Intel® Server System M50CYP1UR204 .....	58
Table 20. Data Cable Guide for Intel® Server System M50CYP1UR212 .....	60
Table 21. M50CYP2UR208 Cable Guide for up to 8 Front Drive Bays .....	63
Table 22. 2U 2.5" SAS/SATA Cable Guide for 9–16 Front Drive Bays .....	66
Table 23. 2U 2.5" PCIe* NVMe* Cable Guide for 9–16 Front Drive Bays .....	68
Table 24. 2U 2.5" SAS / SATA Cable Guide for 17–24 Front Drive Bays .....	70
Table 25. 2U 2.5" PCIe* NVMe* Cable Guide for 17–24 Front Drive Bays.....	72
Table 26. 2U 12 x 3.5" M50CYP2UR312 SAS / SATA / NVMe* Cable Guide.....	73
Table 27. 1U Riser Card Option .....	75
Table 28. 2U Riser Card Options .....	77
Table 29. Intel® Ethernet Network Adapters for OCP* .....	82

Table 30. Intel® Integrated RAID Module RMSP3 Product Family – SAS 3.0 (12 Gb/s) and PCIe 3.0 .....	85
Table 31. Intel® RAID Controller Add-in Cards – SAS 3.0 (12 Gb/s) and PCIe 3.0.....	87
Table 32. Intel® RAID Controller Add-in Cards – SAS 3.0 (12 Gb/s) and NVMe* PCIe* 4.0 .....	88
Table 33. Optional VROC 7.5 Upgrade Key - Supported NVMe* RAID Features.....	89
Table 34. Intel® VROC Key Option .....	90
Table 35. Intel® RAID Accessory Options.....	91
Table 36. Power Supply Modules and Power Cords.....	92
Table 37. Rack Mount Kits.....	95
Table 38. Miscellaneous Accessory Options.....	97
Table 39. Spare and Replacement Parts.....	101

# 1. Overview

This document provides a catalog of available Intel server products, accessories, and spares for the Intel® Server M50CYP Family.



**Figure 1. Intel® Server M50CYP Family Overview**

For a complete overview of the Intel® Server Board M50CYP2SB features and functions, see the *Intel® Server Board M50CYP2SB Technical Product Specification (TPS)*.

For a complete overview of the Intel® Server System M50CYP1UR features and functions, see the *Intel® Server System M50CYP1UR Technical Product Specification (TPS)*.

For a complete overview of the Intel® Server System M50CYP2UR features and functions, see the *Intel® Server System M50CYP2UR Technical Product Specification (TPS)*.

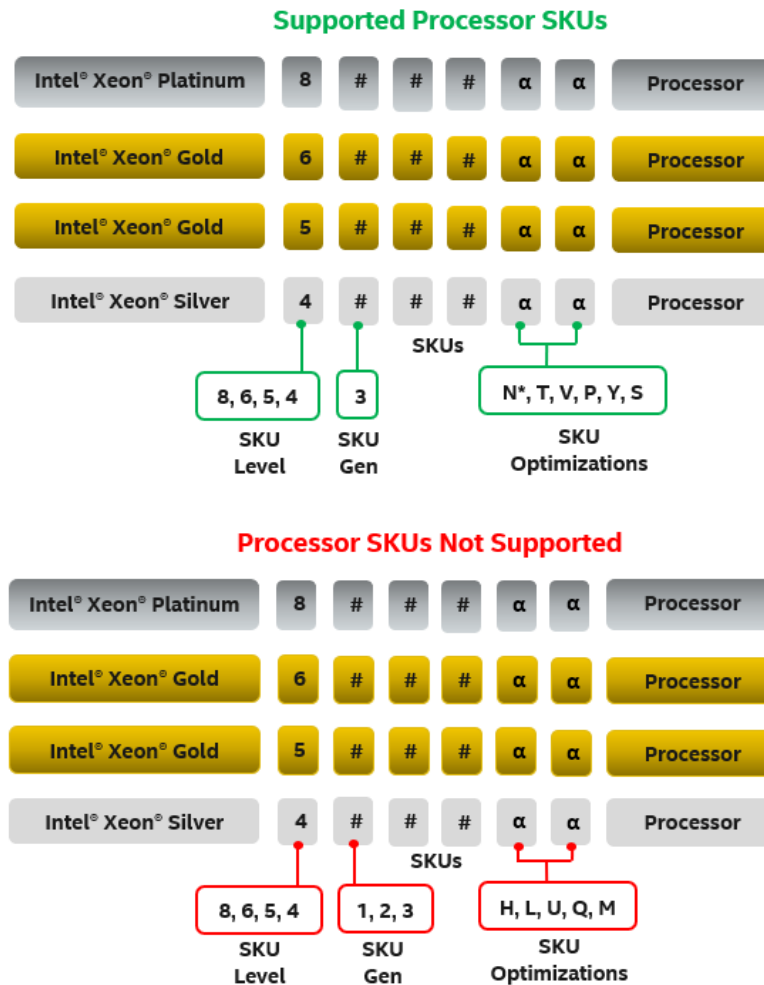
## 1.1 Configuration Overview

The Intel Server M50CYP Family is offered as both server board options and L6 integrated server systems.

- Server board options:
  - **Intel® Server Board M50CYP2SB1U**
  - **Intel® Server Board M50CYP2SBSTD**
- Integrated server system (L6) options:
  - **Intel® Server System M50CYP1UR** – 1U rack mount server systems integrated at level L6 with an Intel® Server Board M50CYP2SB1U and chassis.
  - **Intel® Server System M50CYP2UR** – 2U rack mount server systems integrated at level L6 with an Intel® Server Board M50CYP2SBSTD and chassis.

### 1.1.1 Processor Support

The Intel Server M50CYP Family supports the 3<sup>rd</sup> Gen Intel® Xeon® Scalable processor family. Processor shelves within the product family are identified as shown in the following figure.



**Figure 2. 3<sup>rd</sup> Gen Intel® Xeon® Scalable Processor Identification**

**Notes:**

- Supported 3<sup>rd</sup> Gen Intel Xeon Scalable processor SKUs must not end in (H), (L), (U), (Q), or (M). All other processor SKUs are supported.
- The 8351N SKU is a single-socket optimized SKU and is not supported on the Intel Server M50CYP Family.

The Intel Server M50CYP Family supports the following 3<sup>rd</sup> Gen Intel Xeon Scalable processor family shelves:

- Intel® Xeon® Platinum 8300 processors
- Intel® Xeon® Gold 6300 processors
- Intel® Xeon® Gold 5300 processors
- Intel® Xeon® Silver 4300 processors

**Note:** Previous generation Intel Xeon processors and previous-generation processor heat sinks are not compatible on server boards and server systems described in this document.

**Table 1. 3<sup>rd</sup> Gen Intel® Xeon® Scalable Processor Family Feature Comparison**

Feature	Platinum 8300 Processors	Gold 6300 Processors	Gold 5300 Processors	Silver 4300 Processor
# of Intel® UPI Links	3	3	3	2
Intel® UPI Speed	11.2 GT/s	11.2 GT/s	11.2 GT/s	10.4 GT/s
Supported Topologies	2S-2UPI 2S-3UPI	2S-2UPI 2S-3UPI	2S-2UPI 2S-3UPI	2S-2UPI
Node Controller Support	No	No	No	No
RAS Capability	Advanced	Advanced	Advanced	Standard
Intel® Turbo Boost Technology	Yes	Yes	Yes	Yes
Intel® HT Technology	Yes	Yes	Yes	Yes
Intel® AVX-512 ISA Support	Yes	Yes	Yes	Yes
Intel® AVX-512 - # of 512b FMA Units	2	2	2	2
# of PCIe* Lanes	64	64	64	64
Intel® VMD	Yes	Yes	Yes	Yes

**Note:** Features may vary between processor SKUs.

Reference 3<sup>rd</sup> Gen Intel Xeon Scalable processor specification sheets and product briefs for additional information.

### 1.1.2 Memory Support

The Intel Server M50CYP Family supports the following memory features:

- 32 DIMM slots
  - 16 DIMM slots per processor, eight memory channels per processor
  - Two DIMMs per channel
- Memory capacity
  - Up to 6 TB per processor (processor SKU dependent)
- Memory data transfer rates
  - Up to 3200 MT/s at one or two DIMMs per channel
- Registered DDR4 RDIMM, 3DS-RDIMM, Load Reduced DDR4 (LRDIMM), 3DS-LRDIMM  
**Note:** 3DS = 3 Dimensional Stacking.
- Intel® Optane™ persistent memory 200 series
- DDR4 standard voltage of 1.2 V
- All DDR4 DIMMs must support ECC

### 1.1.3 System Configuration Notes

- The Intel Server Board M50CYP2SB supports the 3<sup>rd</sup> Gen Intel Xeon Scalable processor family.
- Previous generation Intel Xeon processors and Intel Xeon Scalable processor families are not supported.
- **Caution:** Installing processors into the processor sockets should be done with great care. Proper processor orientation with the socket should be made before attempting to install the processor. DO NOT touch any of the contact pins within the processor socket. Doing so could result in bending them and rendering the slot inoperable.
- CPU 1 must be populated for Riser Slot #2 and Riser Slot #3 to be functional.
- Do Not install a heat sink on an empty socket.
- For best performance, memory should be populated evenly across channels starting with the BLUE DIMM slot on each channel. For additional details, see the *Intel® Server System M50CYP1UR Technical Product Specification (TPS)* or *Intel® Server System M50CYP2UR Technical Product Specification (TPS)*.
- **Caution:** Update your server platform to the latest system software posted to RDC before attempting any validation testing. Intel highly recommends you read the complete Update Instructions and Release Notes for each software component before updating the system.
- In a 1U system, all cables routed to the front drive bay of the server system are routed through the right, in-between the cable walls and the chassis side walls. The exception are cables from the server board SlimSAS\* connectors that must be routed through the middle of the fan assembly. No cables should be routed above the processors or DIMMs.
- In a 2U system, cables routed to the front of the server system are routed along the chassis side walls. The exception are cables from the server board SlimSAS connectors. These cables must be routed under the fan assembly. No cables should be routed above the processors or DIMMs. The fan assembly must be removed when routing cables. Care should be taken not to pinch any cables when reinstalling the fan assembly.
- The back edge of the server board has a bank of eight diagnostic LEDs that display a sequence of POST codes during the boot process. Should your system hang during POST, the LEDs will display the last POST event run before the hang. The decoder for these POST code LED sequences can be found in the product *Technical Product Specifications (TPS)* document that can be downloaded from RDC.

## Intel DDR4 DIMM Support Disclaimer

Intel validates and will only provide support for system configurations where all installed DDR4 DIMMs have matching “Identical” or “Like” attributes. See [Table 2](#). A system configured concurrently with DDR4 DIMMs from different vendors will be supported by Intel if all other DDR4 “Like” DIMM attributes match.

Intel does not perform system validation testing nor will it provide support for system configurations where all populated DDR4 DIMMs do not have matching “Like” DIMM attributes as listed in [Table 2](#).

Intel will only provide support for Intel server systems configured with DDR4 DIMMs that have been validated by Intel and are listed on Intel's Tested Memory list for the given Intel server product family.

Intel configures and ships pre-integrated L9 server systems. All DDR4 DIMMs within a given L9 server system as shipped by Intel will be identical. All installed DIMMs will have matching attributes as those listed in the “Identical” *DDR4 DIMM4 Attributes* column in [Table 2](#).

When purchasing more than one integrated L9 server system with the same configuration from Intel, Intel reserves the right to use “Like” DIMMs between server systems. At a minimum, “Like” DIMMs will have matching DIMM attributes as listed in the table below. However, the DIMM model #, revision #, or vendor may be different.

For warranty replacement, Intel will make every effort to ship back an exact match to the one returned. However, Intel may ship back a validated “Like” DIMM. A “Like” DIMM may be from the same vendor but may not be the same revision # or model #, or it may be an Intel validated DIMM from a different vendor. At a minimum, all “Like” DIMMs shipped from Intel will match attributes of the original part according to the definition of “Like” DIMMs in the following table.

**Table 2. DDR4 DIMM Attributes Table for “Identical” and “Like” DIMMs**

<ul style="list-style-type: none"> <li>• DDR4 DIMMs are considered “Identical” when ALL listed attributes between the DIMMs match.</li> <li>• Two or more DDR4 DIMMs are considered “Like” DIMMs when all attributes minus the Vendor, and/or DIMM Part # and/or DIMM Revision#, are the same.</li> </ul>			
Attribute	“Identical” DDR4 DIMM Attributes	“Like” DDR4 DIMM Attributes	Possible DDR4 Attribute Values
Vendor	Match	Maybe Different	Memory Vendor Name
DIMM Part #	Match	Maybe Different	Memory Vendor Part #
DIMM Revision #	Match	Maybe Different	Memory Vendor Part Revision #
SDRAM Type	<b>Match</b>	<b>Match</b>	DDR4
DIMM Type	<b>Match</b>	<b>Match</b>	RDIMM, LRDIMM
Speed (MHz)	<b>Match</b>	<b>Match</b>	2666, 2933, 3200
Voltage	<b>Match</b>	<b>Match</b>	1.2V
DIMM Size (GB)	<b>Match</b>	<b>Match</b>	8GB, 16GB, 32GB, 64GB, 128GB, 256GB
Organization	<b>Match</b>	<b>Match</b>	1Gx72; 2Gx72; 4Gx72; 8Gx72; 16Gx72; 32Gx72
DIMM Rank	<b>Match</b>	<b>Match</b>	1R, 2R, 4R, 8R
DRAM Width	<b>Match</b>	<b>Match</b>	x4, x8
DRAM Density	<b>Match</b>	<b>Match</b>	8Gb, 16Gb

## 1.2 Reference Documents and Support Collaterals

For additional information, see the product support collaterals specified in the following table. The following webpage provides support information for the Intel Server M50CYP Family: <https://www.intel.com/content/www/us/en/support/products/200321.html>

**Table 3. Product Family Reference Collaterals**

Topic	Document Title or Support Collateral	Document Classification
System integration instructions and service guidance	<i>Intel® Server System M50CYP2UR System Integration and Service Guide</i>	Public
System integration instructions and service guidance	<i>Intel® Server System M50CYP1UR System Integration and Service Guide</i>	Public
Technical system-level description	<i>Intel® Server System M50CYP2UR Technical Product Specification</i>	Public
Technical system-level description	<i>Intel® Server System M50CYP1UR Family Technical Product Specification</i>	Public
Technical board-level description	<i>Intel® Server Board M50CYP2SB Technical Product Specification</i>	Public
Server configuration guidance and compatibility	<i>Intel® Server M50CYP Family Configuration Guide</i>	Public
Information on the Integrated BMC Web Console	<i>Integrated Baseboard Management Controller Web Console (Integrated BMC Web Console) User Guide</i>	Public
BIOS technical information on Intel® Server M50CYP Family	<i>BIOS Firmware External Product Specification (EPS)</i>	Intel Confidential
BIOS setup information on Intel® Server M50CYP Family	<i>BIOS Setup Utility User Guide</i>	Public
BMC technical information on Intel® Server M50CYP Family	<i>Integrated Baseboard Management Controller Firmware External Product Specification</i>	Intel Confidential
Base specifications for the IPMI architecture and interfaces	<i>Intelligent Platform Management Interface Specification Second Generation v2.0</i>	Intel Confidential
Specifications for the PCIe* 3.0 architecture and interfaces	<i>PCIe Base Specification, Revision 3.0</i> <a href="http://www.pcisig.com/specifications">http://www.pcisig.com/specifications</a>	Public
Specifications for the PCIe* 4.0 architecture and interfaces	<i>PCIe Base Specification, Revision 4.0</i> <a href="http://www.pcisig.com/specifications">http://www.pcisig.com/specifications</a>	Public
Specification for OCP*	<i>Open Compute Project (OCP) Specification</i>	Intel Confidential
TPM for PC Client specifications	<i>TPM PC Client Specifications, Revision 2.0</i>	Intel Confidential
Functional specifications of 3 <sup>rd</sup> Gen Intel® Xeon® Scalable processor family	<i>3<sup>rd</sup> Generation Intel® Xeon® Scalable Processors, Codename Ice Lake-SP External Design Specification (EDS): Document IDs: 574451, 574942, 575291</i>	Intel Confidential

## Intel® Server M50CYP Family Configuration Guide

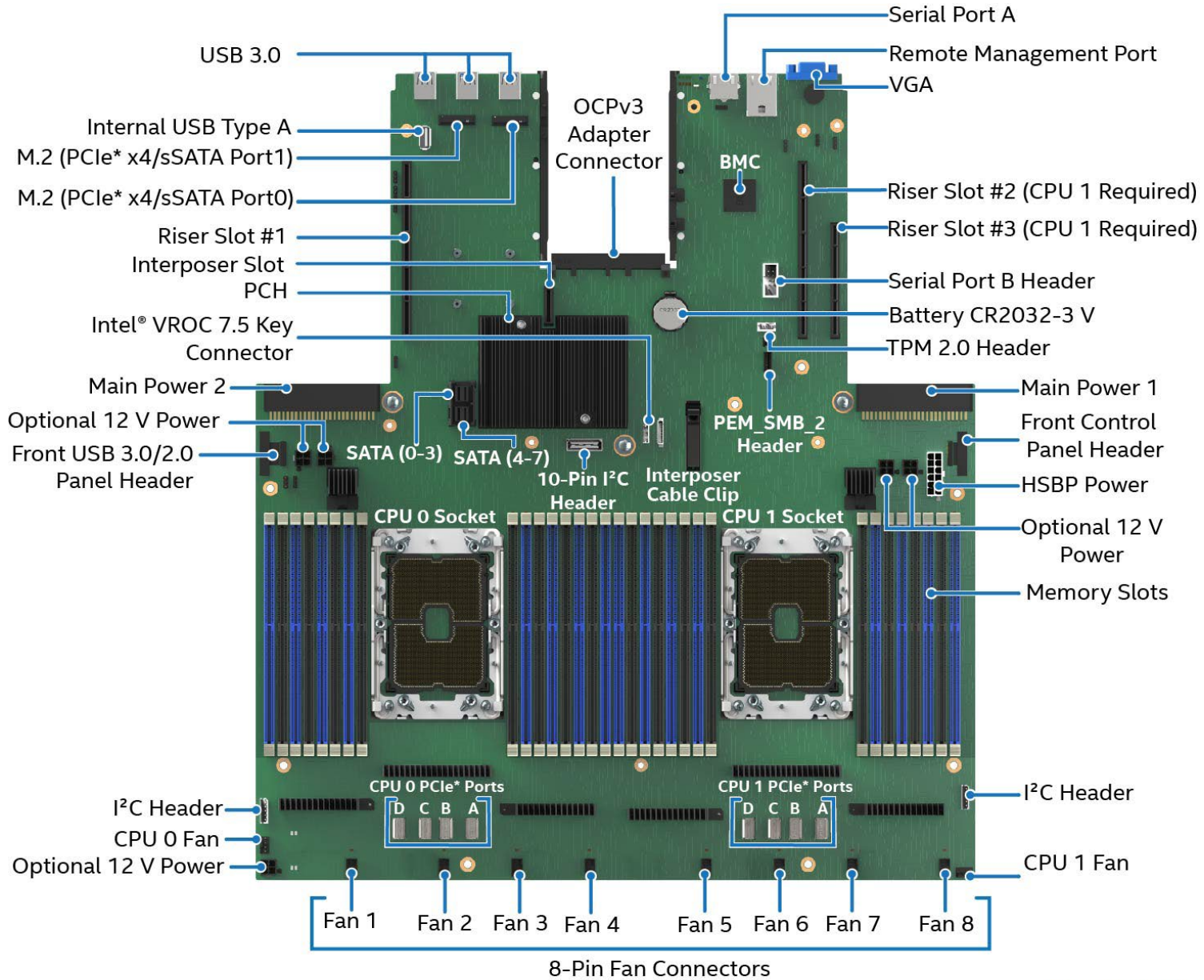
Topic	Document Title or Support Collateral	Document Classification
Processor thermal design specifications and recommendations	<i>3<sup>rd</sup> Generation Intel® Xeon® Scalable Processor, Codename Ice Lake-SP and Cooper Lake-SP - Thermal and Mechanical Specifications and Design Guide (TMSDG)</i> : Document ID 574080	Intel Confidential
BIOS and BMC Security Best Practices	<i>Intel® Server Systems Baseboard Management Controller (BMC) and BIOS Security Best Practices White Paper</i> <a href="https://www.intel.com/content/www/us/en/support/articles/000055785/server-products.html">https://www.intel.com/content/www/us/en/support/articles/000055785/server-products.html</a>	Public
Managing an Intel Server Overview	<i>Managing an Intel Server System 2020</i> <a href="https://www.intel.com/content/www/us/en/support/articles/000057741/server-products.html">https://www.intel.com/content/www/us/en/support/articles/000057741/server-products.html</a>	Public
Technical information on Intel® Optane™ persistent memory 200	<i>Intel® Optane™ Persistent Memory 200 Series Operations Guide</i>	Intel Confidential
Setup information for Intel® Optane™ persistent memory 200	<i>Intel® Optane™ Persistent Memory Startup Guide</i>	Public
Latest system software updates: BIOS and Firmware	<i>Intel® System Update Package (SUP) for Intel® Server M50CYP Family</i>	Public
	<i>Intel® Server Firmware Update Utility - Various operating system support</i>	
	<i>Intel® Server Firmware Update Utility User Guide</i>	
To obtain full system information	<i>Intel® Server Information Retrieval Utility - Various operating system support</i>	Public
	<i>Intel® Server Information Retrieval Utility User Guide</i>	
To configure, save, and restore various system options	<i>Intel® Server Configuration Utility - Various operating system support</i>	Public
	<i>Intel® Server Configuration Utility User Guide</i>	
Product Warranty Information	<i>Warranty Terms and Conditions</i> <a href="https://www.intel.com/content/www/us/en/support/services/000005886.html">https://www.intel.com/content/www/us/en/support/services/000005886.html</a>	Public
Intel® Data Center Manager (Intel® DCM) information	<i>Intel® Data Center Manager (Intel® DCM) Product Brief</i> <a href="https://software.intel.com/content/www/us/en/develop/download/dcm-product-brief.html">https://software.intel.com/content/www/us/en/develop/download/dcm-product-brief.html</a>	Public
	<i>Intel® Data Center Manager (Intel® DCM) Console User Guide</i> <a href="https://software.intel.com/content/www/us/en/develop/download/dcm-user-guide.html">https://software.intel.com/content/www/us/en/develop/download/dcm-user-guide.html</a>	Public

---

**Note:** Intel Confidential documents are made available under a nondisclosure agreement (NDA) with Intel and must be ordered through your local Intel representative.

---

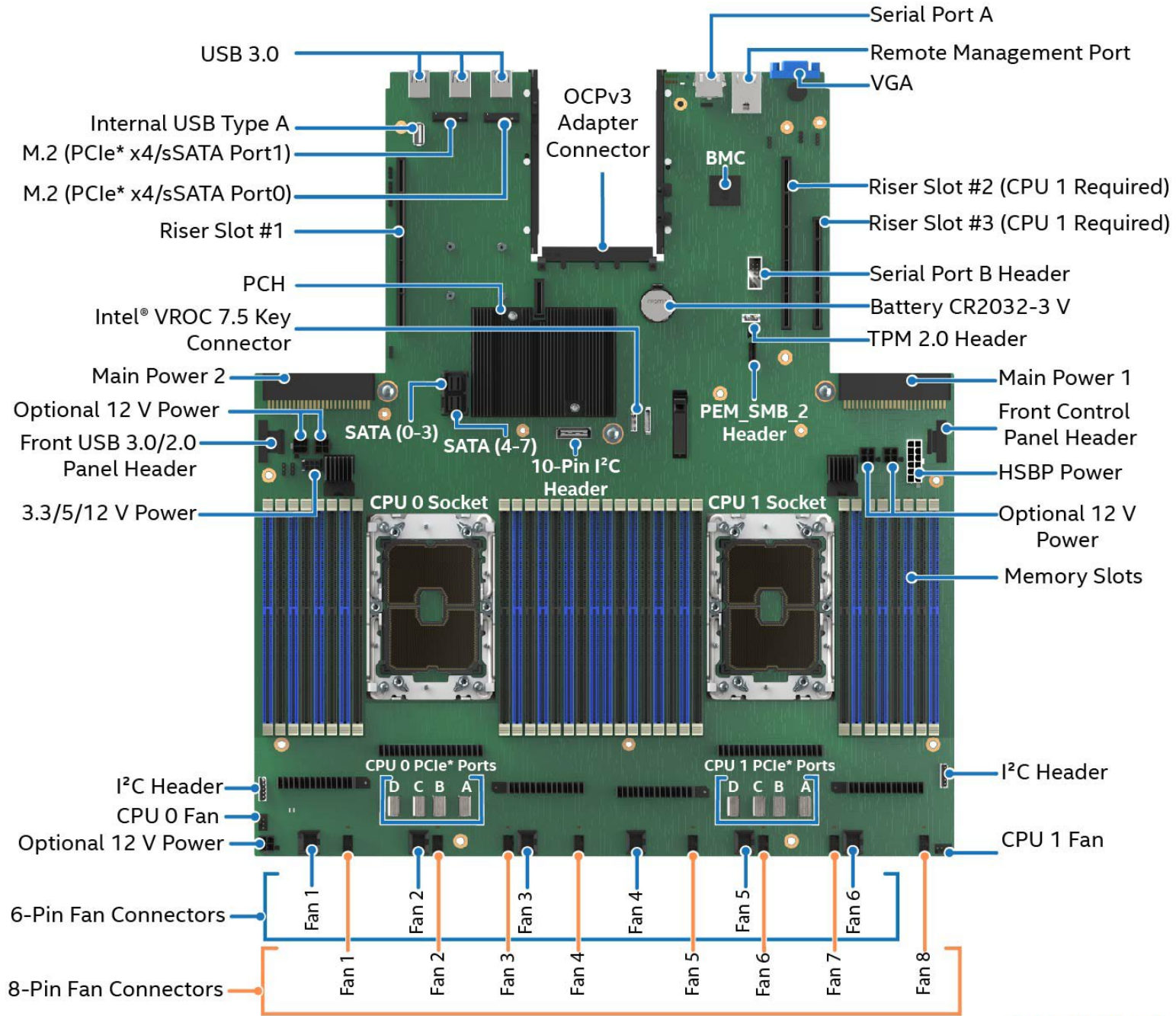
### 1.3 Intel® Server Board M50CYP2SB Options



Ref #: CYP10424

Figure 3. Intel® Server Board M50CYP2SB1U Component / Feature Identification

Intel® Server M50CYP Family Configuration Guide



Ref #: CYP10415

Figure 4. Intel® Server Board M50CYP2SBSTD Component / Feature Identification

Table 4 lists the features of the available server boards in the Intel Server M50CYP Family.

**Table 4. Intel® Server Board M50CYP2SB Features**

Feature	Details
<b>Server Board</b>	<ul style="list-style-type: none"> <li>Intel® Server Board M50CYP2SBSTD and Intel® Server Board M50CYP2SB1U</li> </ul>
<b>Server Board Dimensions</b>	<ul style="list-style-type: none"> <li>477.36 mm length x 427.98 mm width x 1.93 mm thickness</li> </ul>
<b>Processor Support</b>	<ul style="list-style-type: none"> <li>Dual Socket-P4 LGA4189</li> <li>Supported 3<sup>rd</sup> Gen Intel Xeon Scalable processor family SKUs:                             <ul style="list-style-type: none"> <li>Intel® Xeon® Platinum 8300 processor</li> <li>Intel® Xeon® Gold 6300 processor</li> <li>Intel® Xeon® Gold 5300 processor</li> <li>Intel® Xeon® Silver 4300 processor</li> </ul> </li> <li><b>Note:</b> Supported 3<sup>rd</sup> Gen Intel Xeon Scalable processor SKUs must Not end in (H), (L), (U), (Q), or (M). All other processor SKUs are supported.</li> <li>Intel® UPI links: up to three at 11.2 GT/s (Platinum and Gold families) or up to two at 10.4 GT/s (Silver family)</li> <li><b>Note:</b> Previous generation Intel Xeon processors are not supported.</li> </ul>
<b>Maximum Supported Processor Thermal Design Power (TDP)</b>	<ul style="list-style-type: none"> <li>3<sup>rd</sup> Gen Intel Xeon Scalable processors can operate up to 270 W (server board only)</li> <li><b>Note:</b> The maximum supported processor TDP at the system level may be lower than what the server board can support. Supported power, thermal, and configuration limits of the chosen server chassis need to be considered to determine if the system can support the maximum processor TDP limit of the server board. Refer to the server chassis/system documentation for additional guidance.</li> </ul>
<b>PCH Chipset</b>	<ul style="list-style-type: none"> <li>Intel® C621A Chipset Platform Controller Hub (PCH)</li> <li>Embedded features enabled on this server board:                             <ul style="list-style-type: none"> <li>SATA III support</li> <li>USB 3.0 support</li> <li>PCIe 3.0 support</li> </ul> </li> </ul>
<b>Memory Support</b>	<ul style="list-style-type: none"> <li>32 DIMM slots                             <ul style="list-style-type: none"> <li>16 DIMM slots per processor, eight memory channels per processor</li> <li>Two DIMMs per channel</li> </ul> </li> <li>All DDR4 DIMMs must support ECC</li> <li>Registered DDR4 (RDIMM), 3DS-RDIMM, Load Reduced DDR4 (LRDIMM), 3DS-LRDIMM                             <ul style="list-style-type: none"> <li><b>Note:</b> 3DS = 3-Dimensional Stacking</li> </ul> </li> <li>Intel Optane persistent memory 200 series</li> <li>Memory capacity                             <ul style="list-style-type: none"> <li>Up to 6 TB per processor (processor SKU dependent)</li> </ul> </li> <li>Memory data transfer rates                             <ul style="list-style-type: none"> <li>Up to 3200 MT/s at one or two DIMMs per channel (processor SKU dependent)</li> </ul> </li> <li>DDR4 standard voltage of 1.2V</li> </ul>
<b>System Fan Support</b>	<ul style="list-style-type: none"> <li>Six 6-pin fan connectors (Intel Server Board M50CYP2SBSTD)</li> <li>Eight 8-pin fan connectors (Intel Server Board M50CYP2SB1U and M50CYP2SBSTD)</li> <li>CPU fan headers (one for each CPU)</li> </ul>

Feature	Details
<b>Onboard Network Support</b>	Provided by optional Open Compute Project (OCP) module support. See the following feature.
<b>Open Compute Project* (OCP*) Module Support</b>	<p>Onboard x16 PCIe 4.0 OCP 3.0 Mezzanine connector (Small Form-Factor) slot supports the following Intel accessory options:</p> <ul style="list-style-type: none"> <li>• Dual port, RJ45, 10/1 GbE, - iPC – <b>X710T2LOCPV3</b></li> <li>• Quad port, SFP+ DA, 4x 10 GbE – iPC- <b>X710DA4OCPV3</b></li> <li>• Dual Port, QSFP28 100/50/25/10 GbE – iPC- <b>E810CQDA2OCPV3</b></li> <li>• Dual Port, SFP28 25/10 GbE – iPC – <b>E810XXVDA2OCPV3</b></li> </ul>
<b>Riser Card Support</b>	<p>Concurrent support for up to three riser cards with support for up to eight PCIe add-in cards. In the below description FH = Full Height, FL = Full Length, HL =Half Length, LP = Low Profile.</p> <p><b><u>Riser Slot #1:</u></b></p> <ul style="list-style-type: none"> <li>• Riser Slot #1 supports x32 PCIe lanes, routed from CPU 0</li> <li>• PCIe 4.0 support for up to 64 GB/s</li> </ul> <p><b>Riser Slot #1 supports the following Intel Riser Card options:</b></p> <ul style="list-style-type: none"> <li>• Two PCIe slot riser card supporting: (one) FH/FL double-width slot (x16 electrical, x16 mechanical) + (one) FH/HL single-width slot (x16 electrical, x16 mechanical) iPC – <b>CYP2URISER1DBL</b></li> <li>• Three PCIe slot riser card supporting: (one) FH/FL single-width slot (x16 electrical, x16 mechanical) + (one) FH/HL single-width slot (x8 electrical, x16 mechanical) + (one) FH/HL single-width slot (x8 electrical, x8 mechanical) iPC – <b>CYP2URISER1STD</b></li> <li>• NVMe riser card supporting: (one) HL or FL single-width slot (x16 electrical, x16 mechanical) + (two) x8 PCIe NVMe SlimSAS* connectors, each with a re-timer. iPC – <b>CYP2URISER1RTM</b></li> <li>• One PCIe slot riser card supporting: (one) LP/HL, single-width slot (x16 electrical, x16 mechanical) iPC – <b>CYP1URISER1STD</b></li> </ul> <p><b><u>Riser Slot #2:</u></b></p> <ul style="list-style-type: none"> <li>• Riser Slot #2 supports x32 PCIe lanes, routed from CPU 1</li> <li>• PCIe 4.0 support for up to 64 GB/s</li> </ul> <p><b>Riser Slot #2 supports the following Intel Riser Card options:</b></p> <ul style="list-style-type: none"> <li>• Two PCIe slot riser card supporting: (one) FH/FL double-width slot (x16 electrical, x16 mechanical) + (one) FH/HL single-width slot (x16 electrical, x16 mechanical) iPC – <b>CYP2URISER2DBL</b></li> <li>• Three PCIe slot riser card supporting: (one) FH/FL single-width slot (x16 electrical, x16 mechanical) + (one) FH/FL single-width slot (x8 electrical, x16 mechanical) + (one) FH/HL single-width slot (x8 electrical, x8 mechanical) iPC – <b>CYP2URISER2STD</b></li> <li>• One PCIe slot riser card supporting: (one) LP/HL, single-width slot (x16 electrical, x16 mechanical) iPC – <b>CYP1URISER2STD</b></li> <li>• NVMe riser card supporting: (one) LP/HL, single-width slot (x16 electrical, x16 mechanical) + (one) x8 PCIe NVMe SlimSAS connector with re-timer. iPC – <b>CYP1URISER2KIT</b></li> </ul> <p><b><u>PCIe* Interposer Riser Slot</u></b></p> <ul style="list-style-type: none"> <li>• Interposer riser card supports x8 PCIe lanes, route from CPU 1</li> <li>• PCIe 4.0 support for 32 GB/s</li> <li>• PCIe Interposer Riser Slot supports the Intel interposer riser card as an accessory option. This card supports one PCIe add-in card (x8 electrical, x8 mechanical). The PCIe interposer riser card can be used only when it is connected to the PCIe NVMe riser card in Riser Slot #2 (iPC – <b>CYP1URISER2KIT</b>). The interposer card uses x8 PCIe data lanes signals routed from the PCIe SlimSAS connector on the PCIe NVMe riser card. The Intel accessory kit includes the PCIe interposer riser card, PCIe NVMe riser card, and PCIe interposer cable. iPC – <b>CYP1URISER2KIT</b></li> </ul>

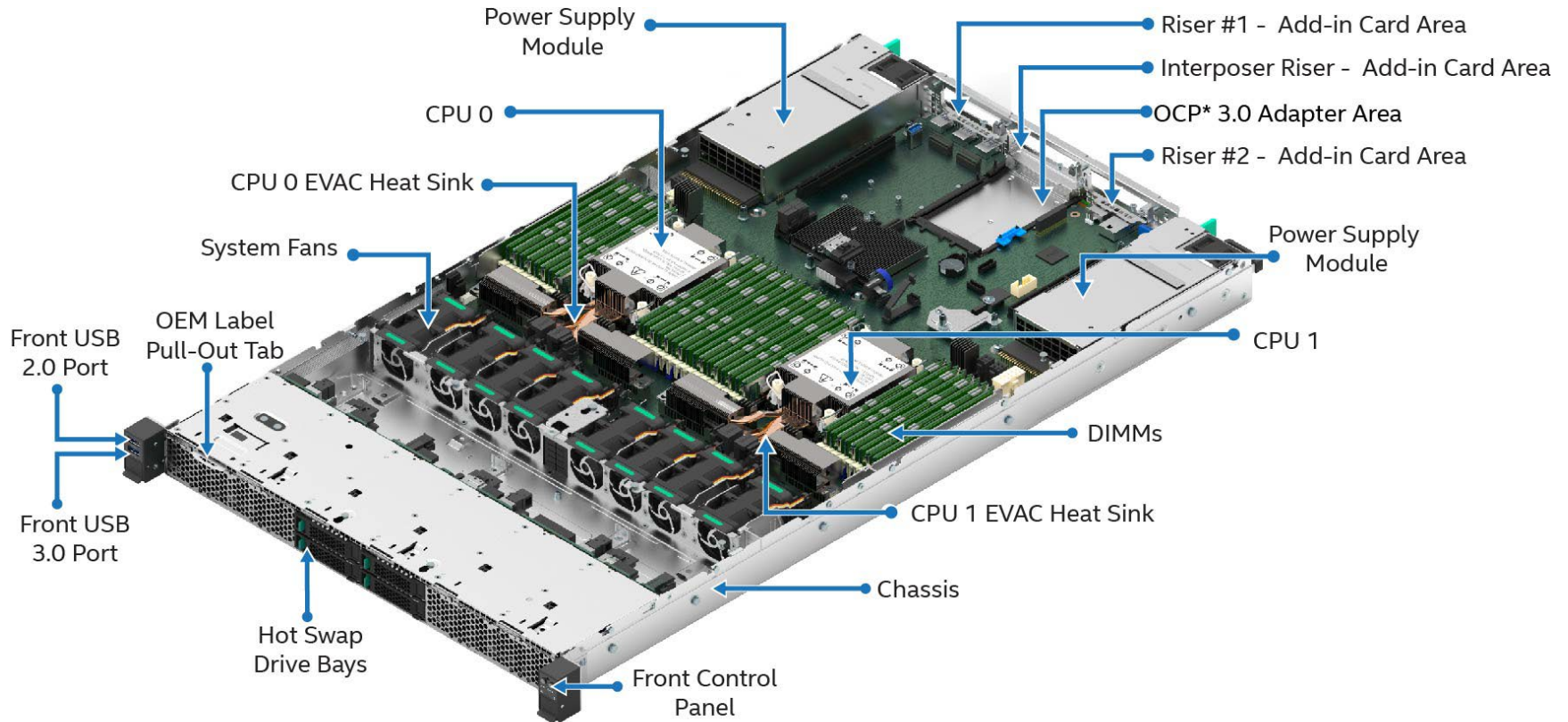
Feature	Details
	<p><b><u>Riser Slot #3:</u></b></p> <ul style="list-style-type: none"> <li>• Riser Slot #3 supports x16 PCIe lanes, route from CPU 1</li> <li>• PCIe 4.0 support for up to 32 GB/s</li> </ul> <p><b>Riser Slot #3 supports the following Intel Riser Card options:</b></p> <ul style="list-style-type: none"> <li>• Two PCIe slot riser card supporting: (two) LP/HL single-width slots (x8 electrical, x16 mechanical) iPC – <b>CYP2URISER3STD</b></li> <li>• NVMe riser card supporting: (two) PCIe NVMe SlimSAS connectors with re-timers iPC – <b>CYPRISER3RTM</b></li> </ul>
<b>PCIe* NVMe* Support</b>	<ul style="list-style-type: none"> <li>• Support for up to 10 PCIe NVMe Interconnects               <ul style="list-style-type: none"> <li>○ Eight onboard SlimSAS connectors, four per processor</li> <li>○ Two M.2 NVMe/SATA connectors</li> </ul> </li> <li>• Additional NVMe support through select PCIe Riser Card options</li> <li>• Intel® Volume Management Device (Intel® VMD) 2.0 support</li> <li>• Intel® Virtual RAID on CPU 7.5 (Intel® VROC 7.5) support using one of the three types of VROC keys (available as an Intel accessory option)</li> </ul>
<b>Video Support</b>	<ul style="list-style-type: none"> <li>• Integrated 2D video controller</li> <li>• 128 MB of DDR4 video memory</li> <li>• One VGA DB-15 external connector in the back</li> </ul>
<b>Onboard SATA Support</b>	<ul style="list-style-type: none"> <li>• 10 x SATA III ports (6 Gb/s, 3 Gb/s, and 1.5 Gb/s transfer rates supported)               <ul style="list-style-type: none"> <li>○ Two M.2 connectors – SATA / PCIe</li> <li>○ Two 4-port Mini-SAS HD (SFF-8643) connectors</li> </ul> </li> </ul>
<b>USB Support</b>	<ul style="list-style-type: none"> <li>• Three external USB 3.0 connectors intended for rear of chassis use.</li> <li>• Internal 26-pin connector for optional one USB 3.0 port and one USB 2.0 port front panel support</li> <li>• One USB 2.0 internal Type-A header</li> </ul>
<b>Serial Support</b>	<ul style="list-style-type: none"> <li>• One external RJ-45 serial-A port connector on the back</li> <li>• One internal DH-10 serial-B port header for optional front or rear serial port support. The port follows DTK pinout specifications.</li> </ul>
<b>Server Management</b>	<ul style="list-style-type: none"> <li>• Integrated Baseboard Management Controller (BMC)</li> <li>• Intelligent Platform Management Interface (IPMI) 2.0 compliant</li> <li>• Support for Intel® Data Center Manager (Intel® DCM)</li> <li>• Support for Intel® Server Debug and Provisioning Tool (Intel® SDP Tool)</li> <li>• Redfish* compliant</li> <li>• Support for Intel Server Management Software</li> <li>• Dedicated onboard RJ45 1 GbE management port</li> <li>• Intel® Light-Guided Diagnostics</li> </ul>
<b>Server Management Processor (SMP)</b>	<ul style="list-style-type: none"> <li>• Aspeed* AST2500 Advanced PCIe Graphics and Remote Management Processor</li> <li>• Embedded features enabled on this server board:               <ul style="list-style-type: none"> <li>○ Baseboard Management Controller (BMC)</li> <li>○ 2D Video Graphics Adapter</li> </ul> </li> </ul>

## Intel® Server M50CYP Family Configuration Guide

Feature	Details
<b>System Configuration and Recovery Jumpers</b>	<ul style="list-style-type: none"> <li>• BIOS load defaults</li> <li>• BIOS Password clear</li> <li>• Intel® Management Engine firmware force update jumper</li> <li>• BMC force update</li> <li>• BIOS_SVN Downgrade</li> <li>• BMC_SVN Downgrade</li> </ul>
<b>Security Support</b>	<ul style="list-style-type: none"> <li>• Intel® Platform Firmware Resilience (Intel® PFR) technology with an I<sup>2</sup>C interface</li> <li>• Intel® Software Guard Extensions (Intel® SGX)</li> <li>• Converged Intel® Boot Guard and Trusted Execution Technology (Intel® TXT)</li> <li>• Intel® Total Memory Encryption (Intel® TME)</li> <li>• Trusted platform module 2.0 (Rest of World) – iPC <b>J33567-151</b> (accessory option)</li> <li>• Trusted platform module 2.0 (China Version) – iPC <b>J12350-150</b> (accessory option)</li> </ul>
<b>BIOS</b>	Unified Extensible Firmware Interface (UEFI)-based BIOS (legacy boot not supported)

## 1.4 Intel® Server System M50CYP1UR

This section gives an overview of the available systems for the Intel Server System M50CYP1UR.



Ref #: CYP30238

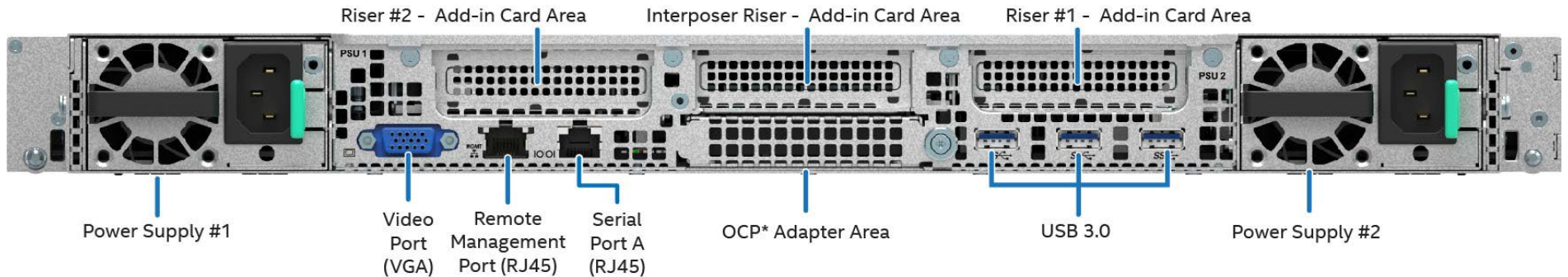
Figure 5. Server System Components Overview



Figure 6. 4 x 2.5" front Drive Bay Configuration – M50CYP1UR204



Figure 7. 12 x 2.5" front Drive Bay Configuration – M50CYP1UR212



Ref #: CYP30147

Figure 8. Back Panel Feature Identification

Table 5. Intel® Server System M50CYP1UR Features

Feature	Details
Chassis Type	1U rack mount chassis
Server Board	Intel Server Board M50CYP2SB1U
Processor Support	<ul style="list-style-type: none"> <li>Dual Socket-P4 LGA4189</li> <li>Supported 3<sup>rd</sup> Gen Intel Xeon Scalable processor family SKUs:                             <ul style="list-style-type: none"> <li>Intel® Xeon® Platinum 8300 processor</li> <li>Intel® Xeon® Gold 6300 processor</li> <li>Intel® Xeon® Gold 5300 processor</li> <li>Intel® Xeon® Silver 4300 processor</li> </ul> </li> <li><b>Note:</b> Supported 3<sup>rd</sup> Gen Intel Xeon Scalable processor SKUs must Not end in (H), (L), (U), (Q), or (M). All other processor SKUs are supported.</li> <li>Intel UPI links: up to three at 11.2 GT/s (Platinum and Gold families) or up to two at 10.4 GT/s (Silver family)</li> <li><b>Note:</b> Previous generation Intel Xeon processor and Intel Xeon Scalable processor families are not supported.</li> </ul>
Maximum Supported Processor Thermal Design Power (TDP)	<ul style="list-style-type: none"> <li>3<sup>rd</sup> Gen Intel Xeon Scalable processors up to 270 W.</li> <li><b>Note:</b> The maximum supported processor TDP depends on system configuration.</li> </ul>

## Intel® Server M50CYP Family Configuration Guide

Feature	Details
<b>PCH Chipset</b>	<ul style="list-style-type: none"> <li>• Intel C621A Chipset Platform Controller Hub (PCH)</li> <li>• Embedded features enabled on this server board:                             <ul style="list-style-type: none"> <li>○ SATA III support</li> <li>○ USB 3.0 support</li> <li>○ PCIe 3.0 support</li> </ul> </li> </ul>
<b>Memory Support</b>	<ul style="list-style-type: none"> <li>• 32 DIMM slots                             <ul style="list-style-type: none"> <li>○ 16 DIMM slots per processor, eight memory channels per processor</li> <li>○ Two DIMMs per channel</li> </ul> </li> <li>• All DDR4 DIMMs must support ECC</li> <li>• Registered DDR4 (RDIMM), 3DS-RDIMM, Load Reduced DDR4 (LRDIMM), 3DS-LRDIMM  <b>Note:</b> 3DS = 3 Dimensional Stacking.</li> <li>• Intel Optane persistent memory 200 series</li> <li>• Memory capacity                             <ul style="list-style-type: none"> <li>○ Up to 6 TB per processor (processor SKU dependent)</li> </ul> </li> <li>• Memory data transfer rates                             <ul style="list-style-type: none"> <li>○ Up to 3200 MT/s at one or two DIMMs per channel (processor SKU dependent)</li> </ul> </li> <li>• DDR4 standard voltage of 1.2V</li> </ul>
<b>System Fans</b>	<ul style="list-style-type: none"> <li>• Eight managed 40 mm hot swap capable system fans</li> <li>• Integrated fans included with each installed power supply module</li> </ul> <p><b>Note:</b> System fan redundancy is supported on specific system configurations.</p>
<b>Power Supply Options</b>	<p>The server system can have up to two power supply modules installed, supporting the following power configurations: 1+0, 1+1 redundant power, and 2+0 combined power.</p> <p>Two power supply options:</p> <ul style="list-style-type: none"> <li>• AC 1300 W Titanium</li> <li>• AC 1600 W Titanium</li> </ul>
<b>Server Board Network Support</b>	<p>See optional Open Compute Project (OCP) adapter support below.</p>
<b>Open Compute Project* (OCP*) Adapter Support</b>	<p>Onboard x16 PCIe 4.0 OCP 3.0 Mezzanine connector (Small Form-Factor) supports the following Intel accessory options:</p> <ul style="list-style-type: none"> <li>• Dual port, RJ45, 10/1 GbE - iPC- <b>X710T2LOCPV3</b></li> <li>• Quad port, SFP+ DA, 4x 10 GbE - iPC- <b>X710DA4OCPV3</b></li> <li>• Dual Port, QSFP28 100/50/25/10 GbE - iPC- <b>E810CQDA2OCPV3</b></li> <li>• Dual Port, SFP28 25/10 GbE - iPC- <b>E810XXVDA2OCPV3</b></li> </ul>

Feature	Details
<b>Riser Card Support</b>	<p>Concurrent support for up to four riser cards, including one PCIe Interposer riser card with support for up to three PCIe add-in cards. In the below description HL = Half Length, LP = Low Profile.</p> <p><b><u>Riser Slot #1:</u></b></p> <ul style="list-style-type: none"> <li>• Riser Slot #1 supports x16 PCIe lanes routed from CPU 0</li> <li>• PCIe 4.0 support for up to 32 GB/s</li> </ul> <p><b>Riser Slot #1 supports the following Intel Riser Card option:</b></p> <ul style="list-style-type: none"> <li>• One PCIe slot riser card supporting: (one) LP/HL, single-width slot (x16 electrical, x16 mechanical) iPC – <b>CYP1URISER1STD</b></li> </ul> <p><b><u>Riser Slot #2:</u></b></p> <ul style="list-style-type: none"> <li>• Riser Slot #2 supports x24 PCIe lanes routed from CPU 1</li> <li>• PCIe 4.0 support for up to 32 GB/s</li> </ul> <p><b>Riser Slot #2 supports the following Intel Riser Card options:</b></p> <ul style="list-style-type: none"> <li>• One PCIe slot riser card supporting: (one) LP/HL, single-width slot (x16 electrical, x16 mechanical) iPC – <b>CYP1URISER2STD</b></li> <li>• NVMe riser card supporting: (one) LP/HL, single-width slot (x16 electrical, x16 mechanical) + (one) x8 PCIe NVMe SlimSAS connector with re-timer. Included in iPC – <b>CYP1URISER2KIT</b></li> </ul> <p><b>PCIe* Interposer Riser Slot (requires PCIe* riser card in Riser Slot #2)</b></p> <ul style="list-style-type: none"> <li>• PCIe Interposer Riser Slot supports the PCIe interposer riser card as an accessory option. This card supports one PCIe add-in card (x8 electrical, x8 mechanical). The PCIe interposer riser card can be used only when it is connected to the PCIe NVMe riser card in Riser Slot #2. The interposer card uses x8 PCIe data lanes routed from the PCIe SlimSAS connector on the PCIe riser card. The Intel accessory kit includes the PCIe interposer riser card, PCIe riser card, and PCIe interposer cable. iPC – <b>CYP1URISER2KIT</b></li> </ul> <p><b><u>Riser Slot #3:</u></b></p> <ul style="list-style-type: none"> <li>• Riser Slot #3 supports x16 PCIe lanes routed from CPU 1</li> <li>• PCIe 4.0 support for up to 32 GB/s</li> </ul> <p><b>Riser Slot #3 supports the following Intel Riser Card option:</b></p> <ul style="list-style-type: none"> <li>• NVMe riser card supporting: (two) PCIe NVMe SlimSAS connectors iPC – <b>CYPRISER3RTM</b></li> </ul> <p><b>Note:</b> Riser Slot #3 does not support add-in cards.</p>
<b>PCIe* NVMe* Support</b>	<ul style="list-style-type: none"> <li>• Support for up to 10 PCIe NVMe Interconnects <ul style="list-style-type: none"> <li>◦ Eight server board SlimSAS connectors, four per processor</li> <li>◦ Two M.2 NVMe/SATA connectors</li> </ul> </li> <li>• Additional NVMe support through select Riser Card options</li> <li>• Intel Volume Management Device 2.0 (Intel VMD 2.0) support</li> <li>• Intel Virtual RAID on CPU 7.5 (Intel VROC 7.5) support using one of the three types of VROC keys (available as an Intel accessory option)</li> </ul>
<b>Video Support</b>	<ul style="list-style-type: none"> <li>• Integrated 2D video controller</li> <li>• 128 MB of DDR4 video memory</li> <li>• One VGA DB-15 external connector in the back</li> </ul>
<b>Server Board SATA Support</b>	<ul style="list-style-type: none"> <li>• 10 x SATA III ports (6 Gb/s, 3 Gb/s, and 1.5 Gb/s transfer rates supported) <ul style="list-style-type: none"> <li>◦ Two M.2 connectors – SATA / PCIe</li> <li>◦ Two 4-port Mini-SAS HD (SFF-8643) connectors</li> </ul> </li> </ul>

## Intel® Server M50CYP Family Configuration Guide

Feature	Details
<b>USB Support</b>	<ul style="list-style-type: none"> <li>• Three USB 3.0 connectors on the back panel</li> <li>• One USB 3.0 and one USB 2.0 connector on the front panel</li> <li>• One USB 2.0 internal Type-A connector</li> </ul>
<b>Serial Support</b>	<ul style="list-style-type: none"> <li>• One external RJ-45 Serial Port A connector on the back panel</li> <li>• One internal DH-10 Serial Port B header for optional front or rear serial port support. The port follows the DTK pinout specifications.</li> </ul>
<b>Front Drive Bay Options</b>	<ul style="list-style-type: none"> <li>• 4 x 2.5" SAS/SATA/NVMe hot swap drive bays</li> <li>• 12 x 2.5" SAS/SATA/NVMe hot swap drive bays</li> </ul>
<b>Server Management</b>	<ul style="list-style-type: none"> <li>• Integrated Baseboard Management Controller (BMC)</li> <li>• Intelligent Platform Management Interface (IPMI) 2.0 compliant</li> <li>• Redfish compliant</li> <li>• Support for Intel Data Center Manager (Intel DCM)</li> <li>• Support for Intel Server Debug and Provisioning Tool (Intel SDP Tool)</li> <li>• Dedicated server board RJ45 1 GbE management port</li> <li>• Intel Light-Guided Diagnostics</li> </ul>
<b>Server Management Processor (SMP)</b>	<ul style="list-style-type: none"> <li>• Aspeed AST2500 Advanced PCIe Graphics and Remote Management Processor</li> <li>• Embedded features enabled on this server board:               <ul style="list-style-type: none"> <li>○ Baseboard Management Controller (BMC)</li> <li>○ 2D Video Graphics Adapter</li> </ul> </li> </ul>
<b>System Configuration and Recovery Jumpers</b>	<ul style="list-style-type: none"> <li>• BIOS load defaults</li> <li>• BIOS Password clear</li> <li>• Intel Management Engine firmware force update jumper</li> <li>• BMC force update</li> <li>• BIOS_SVN Downgrade</li> <li>• BMC_SVN Downgrade</li> </ul> <p>For more information, see the <i>Intel® Server Board M50CYP2SB</i> Technical Product Specification (TPS).</p>
<b>Security Support</b>	<ul style="list-style-type: none"> <li>• Intel Platform Firmware Resilience (Intel PFR) technology with an I<sup>2</sup>C interface</li> <li>• Intel Software Guard Extensions (Intel SGX)</li> <li>• Converged Intel Boot Guard and Trusted Execution Technology (Intel TXT)</li> <li>• Intel Total Memory Encryption (Intel TME)</li> <li>• Trusted platform module 2.0 (Rest of World) – iPC <b>J33567-151</b> (accessory option)</li> <li>• Trusted platform module 2.0 (China Version) – iPC <b>J12350-150</b> (accessory option)</li> </ul>
<b>Supported Rack Mount Kit Accessory Options</b>	<ul style="list-style-type: none"> <li>• <b>CYPHALFEXTRAIL</b> – Value Rack Mount Rail Kit</li> <li>• <b>CYPFULLEXTRAIL</b> – Premium Rail Kit with cable management arm (CMA) support</li> <li>• <b>AXXCMA2</b> – Cable Management Arm (supports <b>CYPFULLEXTRAIL</b> only)</li> </ul>
<b>BIOS</b>	Unified Extensible Firmware Interface (UEFI)-based BIOS (legacy boot not supported)

## 1.5 Intel® Server System M50CYP2UR

This section gives an overview of the available systems for the Intel Server System M50CYP2UR.

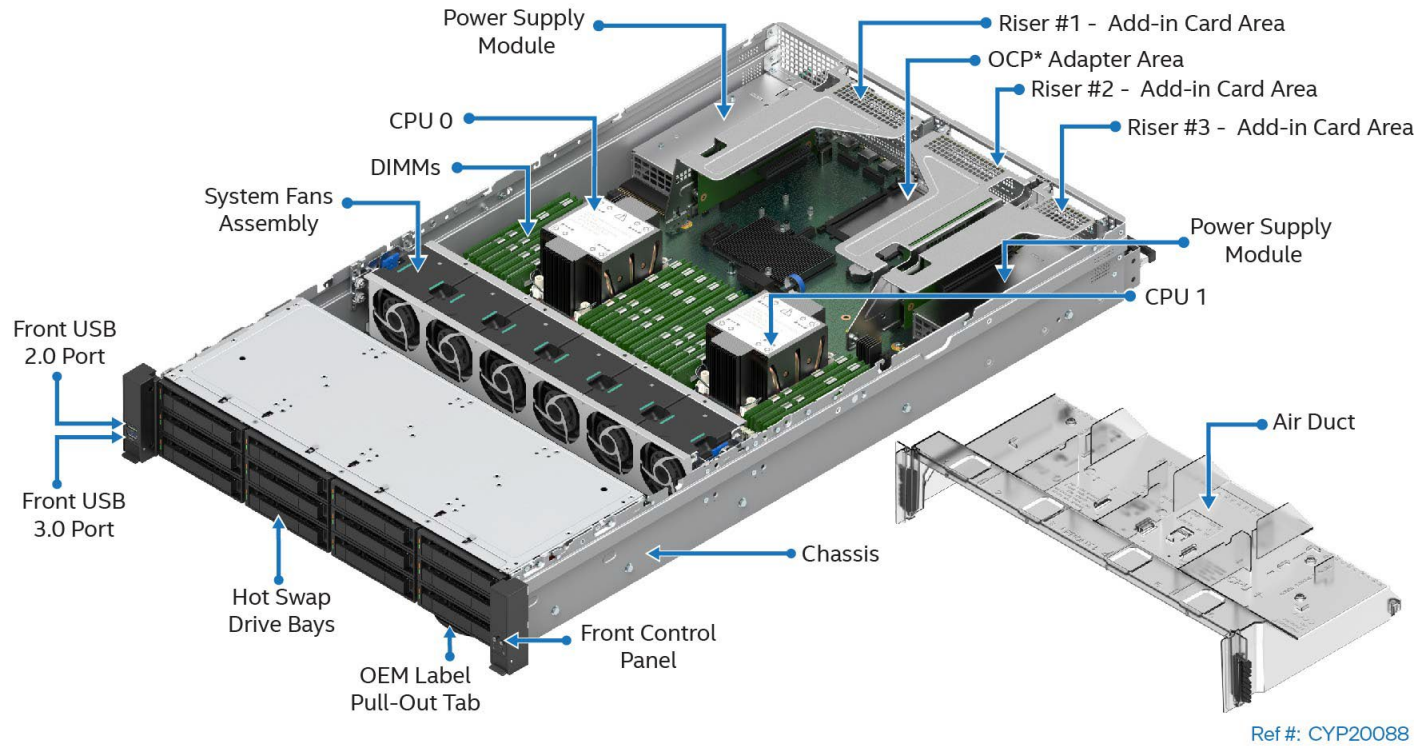


Figure 9. Intel® Server System M50CYP2UR Feature Set Identification



Figure 10. 2U 8 x 2.5" Front Drive Bay Configuration – M50CYP2UR208

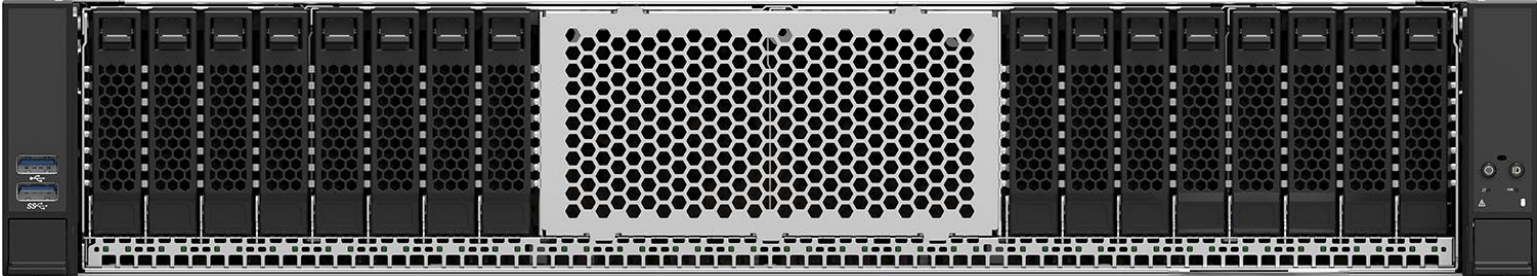


Figure 11. 2U 16 x 2.5" Front Drive Bay Configuration (based on M50CYP2UR208)



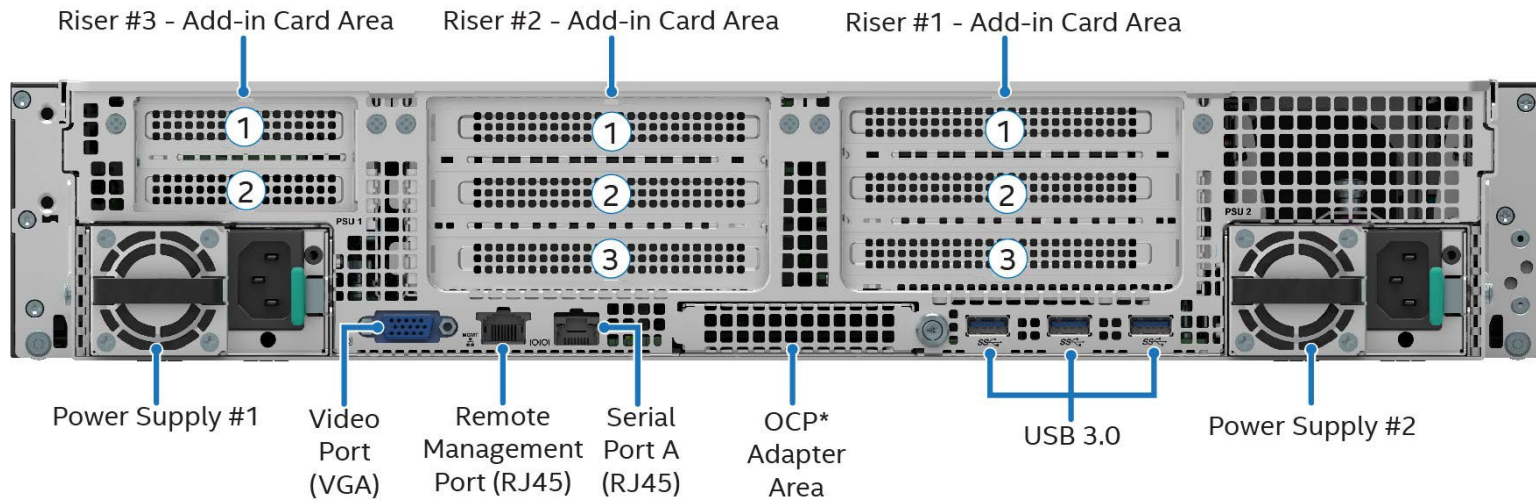
Figure 12. 2U 24 x 2.5" Front Drive Bay Configuration (based on M50CYP2UR208)



CYP20033

Figure 13. 2U 12 x 3.5" Front Drive Bay Configuration – M50CYP2UR312

## Intel® Server M50CYP Family Configuration Guide



Ref #: CYP20076

**Figure 14. 2U Back Panel Feature Identification**

**Table 6. Intel® Server System M50CYP2UR Features**

Feature	Details
<b>Chassis Type</b>	2U rack mount chassis
<b>Server Board</b>	Intel Server Board M50CYP2SBSTD
<b>Processor Support</b>	<ul style="list-style-type: none"> <li>• Dual Socket-P4 LGA4189</li> <li>• Supported 3<sup>rd</sup> Gen Intel Xeon Scalable processor family SKUs: <ul style="list-style-type: none"> <li>○ Intel® Xeon® Platinum 8300 processor</li> <li>○ Intel® Xeon® Gold 6300 processor</li> <li>○ Intel® Xeon® Gold 5300 processor</li> <li>○ Intel® Xeon® Silver 4300 processor</li> </ul> </li> <li>• Intel UPI links: up to three at 11.2 GT/s (Platinum and Gold families) or up to two at 10.4 GT/s (Silver family)</li> </ul> <p><b>Note:</b> Supported 3<sup>rd</sup> Gen Intel Xeon Scalable processor SKUs must Not end in (H), (L), (U), (Q), or (M). All other processor SKUs are supported.</p> <p><b>Note:</b> Previous generation Intel Xeon processor and Intel Xeon Scalable processor families are not supported.</p>
<b>Maximum Supported Processor Thermal Design Power (TDP)</b>	<ul style="list-style-type: none"> <li>• 3<sup>rd</sup> Gen Intel Xeon Scalable processors up to 270 W.</li> </ul> <p><b>Note:</b> The maximum supported processor TDP depends on system configuration.</p>
<b>PCH Chipset</b>	<ul style="list-style-type: none"> <li>• Intel C621A Chipset Platform Controller Hub (PCH)</li> <li>• Embedded features enabled on this server board: <ul style="list-style-type: none"> <li>○ SATA III support</li> <li>○ USB 3.0 support</li> <li>○ PCIe 3.0 support</li> </ul> </li> </ul>

Feature	Details
<b>Memory Support</b>	<ul style="list-style-type: none"> <li>• 32 DIMM slots                             <ul style="list-style-type: none"> <li>○ 16 DIMM slots per processor, eight memory channels per processor</li> <li>○ Two DIMMs per channel</li> </ul> </li> <li>• Registered DDR4 (RDIMM), 3DS-RDIMM, Load Reduced DDR4 (LRDIMM), 3DS-LRDIMM                             <p><b>Note:</b> 3DS = 3 Dimensional Stacking.</p> </li> <li>• All DDR4 DIMMs must support ECC</li> <li>• Intel Optane persistent memory 200 series</li> <li>• Memory capacity                             <ul style="list-style-type: none"> <li>○ Up to 6 TB per processor (processor SKU dependent)</li> </ul> </li> <li>• Memory data transfer rates                             <ul style="list-style-type: none"> <li>○ Up to 3200 MT/s at one or two DIMMs per channel (processor SKU dependent)</li> </ul> </li> <li>• DDR4 standard voltage of 1.2 V</li> </ul>
<b>System Fans</b>	<ul style="list-style-type: none"> <li>• Six managed 60 mm hot swap capable system fans</li> <li>• Integrated fans included with each installed power supply module</li> </ul>
<b>Power Supply Options</b>	<p>The server system can have up to two power supply modules installed, supporting the following power configurations: 1+0, 1+1 redundant power, and 2+0 combined power.</p> <p>Three power supply options:</p> <ul style="list-style-type: none"> <li>• AC 1300 W Titanium</li> <li>• AC 1600 W Titanium</li> <li>• AC 2100 W Platinum</li> </ul>
<b>Onboard Network Support</b>	<p>Provided by optional Open Compute Project (OCP) adapter support. See below.</p>
<b>Open Compute Project* (OCP*) Adapter Support</b>	<p>Server board x16 PCIe 4.0 OCP 3.0 Mezzanine connector (Small Form-Factor) slot supports the following Intel accessory options:</p> <ul style="list-style-type: none"> <li>• Dual port, RJ45, 10/1 GbE - iPC- <b>X710T2LOCPV3</b></li> <li>• Quad port, SFP+ DA, 4x 10 GbE - iPC- <b>X710DA4OCPV3</b></li> <li>• Dual Port, QSFP28 100/50/25/10 GbE - iPC- <b>E810CQDA2OCPV3</b></li> <li>• Dual Port, SFP28 25/10 GbE - iPC- <b>E810XXVDA2OCPV3</b></li> </ul>
<b>Riser Card Support</b>	<p>Concurrent support for up to three riser cards with support for up to eight PCIe add-in cards. In the below description FH = Full Height, FL = Full Length, HL =Half Length, LP = Low Profile.</p> <p><b><u>Riser Slot #1:</u></b></p> <ul style="list-style-type: none"> <li>• Riser Slot #1 supports x32 PCIe lanes, routed from CPU 0</li> <li>• PCIe 4.0 support for up to 64 GB/s</li> </ul> <p><b>Riser Slot #1 supports the following Intel Riser Card options:</b></p> <ul style="list-style-type: none"> <li>• Two PCIe slot riser card supporting: (one) FH/FL double-width slot (x16 electrical, x16 mechanical) + (one) FH/HL single-width slot (x16 electrical, x16 mechanical) iPC – <b>CYP2URISER1DBL</b></li> <li>• Three PCIe slot riser card supporting: (one) FH/FL single-width slot (x16 electrical, x16 mechanical) + (one) FH/FL single-width slot (x8 electrical, x16 mechanical) + (one) FH/HL single-width slot (x8 electrical, x8 mechanical) iPC – <b>CYP2URISER1STD</b></li> <li>• NVMe riser card supporting: (one) HL or FL single-width slot (x16 electrical, x16 mechanical) + (two) x8 PCIe NVMe SlimSAS connectors, each with a re-timer. iPC – <b>CYP2URISER1RTM</b></li> </ul>

Feature	Details
	<p><b><u>Riser Slot #2:</u></b></p> <ul style="list-style-type: none"> <li>• Riser Slot #2 supports x32 PCIe lanes, routed from CPU 1</li> <li>• PCIe 4.0 support for up to 64 GB/s</li> </ul> <p><b>Riser Slot #2 supports the following Intel Riser Card options:</b></p> <ul style="list-style-type: none"> <li>• Two PCIe slot riser card supporting: (one) FH/FL double-width slot (x16 electrical, x16 mechanical) + (one) FH/HL single-width slot (x16 electrical, x16 mechanical) iPC – <b>CYP2URISER2DBL</b></li> <li>• Three PCIe slot riser card supporting: (one) FH/FL single-width slot (x16 electrical, x16 mechanical) + (one) FH/FL single-width slot (x8 electrical, x16 mechanical) + (one) FH/HL single-width slot (x8 electrical, x8 mechanical) iPC – <b>CYP2URISER2STD</b></li> </ul> <p><b><u>Riser Slot #3:</u></b></p> <ul style="list-style-type: none"> <li>• Riser Slot #3 supports x16 PCIe lanes, route from CPU 1</li> <li>• PCIe 4.0 support for up to 32 GB/s</li> </ul> <p><b>Riser Slot #3 supports the following Intel Riser Card options:</b></p> <ul style="list-style-type: none"> <li>• Two PCIe slot riser card supporting: (two) LP/HL single-width slots (x8 electrical, x16 mechanical) iPC – <b>CYP2URISER3STD</b></li> <li>• NVMe riser card supporting: (two) PCIe NVMe SlimSAS connectors with re-timers iPC – <b>CYPRISER3RTM</b></li> </ul>
<b>PCIe* NVMe* Support</b>	<ul style="list-style-type: none"> <li>• Support for up to 10 PCIe NVMe Interconnects <ul style="list-style-type: none"> <li>◦ Eight server board SlimSAS connectors, four per processor</li> <li>◦ Two M.2 NVMe/SATA connectors</li> </ul> </li> <li>• Additional NVMe support through select Riser Card options</li> <li>• Intel Volume Management Device (Intel VMD) 2.0 support</li> <li>• Intel Virtual RAID on CPU 7.5 (Intel VROC 7.5) support using one of the three types of VROC keys (available as an Intel accessory option)</li> </ul>
<b>Video Support</b>	<ul style="list-style-type: none"> <li>• Integrated 2D video controller</li> <li>• 128 MB of DDR4 video memory</li> <li>• One VGA DB-15 external connector in the back</li> </ul>
<b>Onboard SATA Support</b>	<ul style="list-style-type: none"> <li>• 10 x SATA III ports (6 Gb/s, 3 Gb/s, and 1.5 Gb/s transfer rates supported) <ul style="list-style-type: none"> <li>◦ Two M.2 connectors – SATA/PCIe</li> <li>◦ Two 4-port Mini-SAS HD (SFF-8643) connectors</li> </ul> </li> </ul>
<b>USB Support</b>	<ul style="list-style-type: none"> <li>• Three USB 3.0 connectors on the back panel</li> <li>• One USB 3.0 and one USB 2.0 connector on the front panel</li> <li>• One USB 2.0 internal Type-A connector</li> </ul>
<b>Serial Support</b>	<ul style="list-style-type: none"> <li>• One external RJ-45 Serial Port A connector on the back panel</li> <li>• One internal DH-10 Serial Port B header for optional front or rear serial port support. The port follows DTK pinout specifications.</li> </ul>
<b>Front Drive Bay Options</b>	<ul style="list-style-type: none"> <li>• 8 x 2.5" SAS/SATA/NVMe hot swap drive bays</li> <li>• 16 x 2.5" SAS/SATA/NVMe hot swap drive bays</li> <li>• 24 x 2.5" SAS/SATA/NVMe hot swap drive bays</li> <li>• 12 x 3.5" SAS/SATA hot swap drive bays (supports up to 4 NVMe drives)</li> </ul>

## Intel® Server M50CYP Family Configuration Guide

Feature	Details
<b>Server Management</b>	<ul style="list-style-type: none"> <li>• Integrated Baseboard Management Controller (BMC)</li> <li>• Intelligent Platform Management Interface (IPMI) 2.0 compliant</li> <li>• Redfish compliant</li> <li>• Support for Intel Data Center Manager (Intel DCM)</li> <li>• Support for Intel Server Debug and Provisioning Tool (Intel SDP Tool)</li> <li>• Support for Intel Server Management Software</li> <li>• Dedicated server board RJ45 1 GbE management port</li> <li>• Intel Light-Guided Diagnostics</li> </ul>
<b>Server Management Processor (SMP)</b>	<ul style="list-style-type: none"> <li>• Aspeed AST2500 Advanced PCIe Graphics and Remote Management Processor</li> <li>• Embedded features enabled on this server board:                             <ul style="list-style-type: none"> <li>○ Baseboard Management Controller (BMC)</li> <li>○ 2D Video Graphics Adapter</li> </ul> </li> </ul>
<b>System Configuration and Recovery Jumpers</b>	<ul style="list-style-type: none"> <li>• BIOS load defaults</li> <li>• BIOS Password clear</li> <li>• Intel Management Engine firmware force update jumper</li> <li>• BMC force update</li> <li>• BIOS_SVN Downgrade</li> <li>• BMC_SVN Downgrade</li> </ul> <p>For more information, see the <i>Intel® Server Board M50CYP2SB Technical Product Specification (TPS)</i>.</p>
<b>Security Support</b>	<ul style="list-style-type: none"> <li>• Intel Platform Firmware Resilience (Intel PFR) technology with an I<sup>2</sup>C interface</li> <li>• Intel Software Guard Extensions (Intel SGX)</li> <li>• Converged Intel Boot Guard and Trusted Execution Technology (Intel TXT)</li> <li>• Intel Total Memory Encryption (Intel TME)</li> <li>• Trusted platform module 2.0 (Rest of World) – iPC <b>J33567-151</b> (accessory option)</li> <li>• Trusted platform module 2.0 (China Version) – iPC <b>J12350-150</b> (accessory option)</li> </ul>
<b>Supported Rack Mount Kit Accessory Options</b>	<p><b>CYPHALFEXTRAIL</b> –Value Rack Mount Rail Kit</p> <p><b>CYPFULLEXTRAIL</b> – Premium Rail Kit with cable management arm (CMA) support</p> <p><b>AXXCMA2</b> – Cable Management Arm (supports <b>CYPFULLEXTRAIL</b> only)</p>
<b>BIOS</b>	Unified Extensible Firmware Interface (UEFI)-based BIOS (legacy boot not supported)

## 1.6 Available Server Board, Chassis, and System SKU Summary

The following tables provide an overview of available Intel product codes for server boards and systems in the Intel Server M50CYP Family. Each line item identifies key features supported in the shipping Intel SKU. Additional order code information and full product descriptions for each option are provided in later sections.

The following terms are used in the tables:

- **N/A:** Not applicable.
- **Opt:** Accessory option sold separately.
- **Yes:** Option included.
- **BIK:** Intel term for integrated (L6 and L9) system product.
- **L3:** Server System Building Block – Server board only
- **L6:** Integrated system – Chassis and server board, with no processors, memory, power supply, or storage devices.

**Table 7. Server Board (L3) Family Summary**

Intel Product Code (iPC)	# of CPU sockets	# of DIMM Slots	# of Riser Slots	Onboard SATA ports (6 Gb)	Onboard NVMe* Ports	Intel® SAS RAID Module support	Intel® Ethernet Network Adapter for OCP* Support	Onboard Video	Onboard System Fan	EVAC Heat Sink Support
M50CYP2SB1U	2	32	3	8	8	Opt	Opt	Yes	8	Yes
M50CYP2SBSTD	2	32	3	8	8	Opt	Opt	Yes	6	No

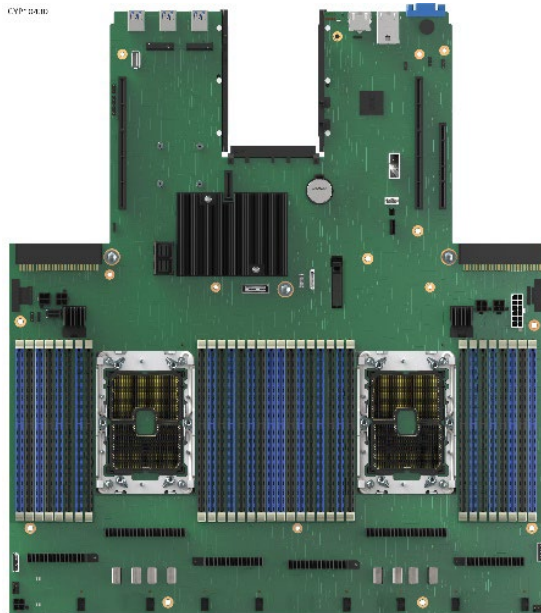
**Table 8. Server System (L6 BIK) Family Summary**

Intel Product Code (iPC)	Chassis Form Factor	Server Board Option	Drive Form Factor	# of Drives (front)	2.5" NVMe* Support	# of SSD Drives (internal fixed)	# of PCIe* Add-in Card Slots	Power Supply Modules	Rails	SAS RAID	SAS Expander	Memory Included	Processor Included
M50CYP1UR212	1U	M50CYP2SB1U	2.5"	12	Opt (up to 12)	N/A	3	Opt (up to 2)	Opt	Opt (up to 1)	Opt (up to 1)	No	No
M50CYP1UR204	1U	M50CYP2SB1U	2.5"	4	Opt (up to 4)	N/A	3	Opt (up to 2)	Opt	Opt (up to 1)	Opt (up to 1)	No	No
M50CYP2UR208	2U	M50CYP2SBSTD	2.5"	8, 16, 24	Opt (up to 24)	Opt (up to 2)	8	Opt (up to 2)	Opt	Opt (up to 1)	Opt (up to 1)	No	No
M50CYP2UR312	2U	M50CYP2SBSTD	3.5"	12	Opt (up to 4)	Opt (up to 2)	8	Opt (up to 2)	Opt	Opt (up to 1)	Opt (up to 1)	No	No

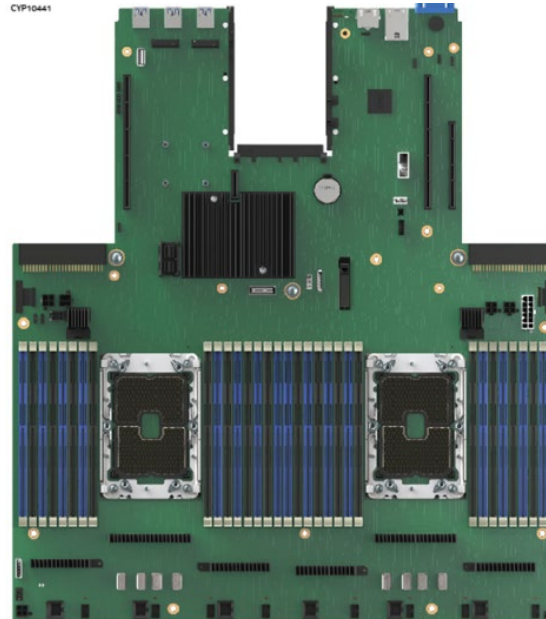
## 2. Server Board Options

Server board options are offered to create a custom system configuration from the board up. Each building block component and optional accessory is purchased separately and assembled by a system integrator. At a minimum, a base functional server system using building blocks requires the following:

- Server Chassis (Not sold by Intel)
- Intel Server Board M50CYP2SB1U or M50CYP2SBSTD options
- Power supply module(s)
- SATA/NVMe data cables
- Power cord(s)
- Rack mount kit – rails or fixed mount
- Processor
- Memory
- Storage devices



Intel® Server Board M50CYP2SB1U



Intel® Server Board M50CYP2SBSTD



Power supply modules



PCIe\* riser cards

**Figure 15. Illustration of Building Block Options**

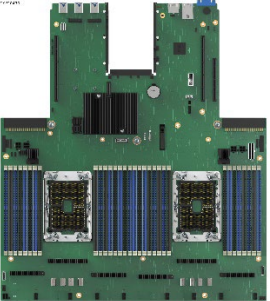
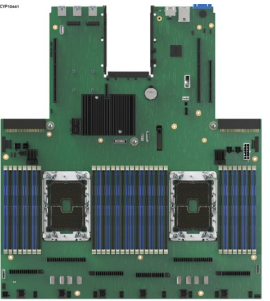
Optional Intel accessories that can be added include the following:

- PCIe riser card options
- Intel® RAID Controllers/Storage Adapters support – PCIe add-in card and appropriate SAS data cable(s)
- Intel® Ethernet Network Adapter for OCP\* – To add additional features without losing a PCIe add-in slot

See [Chapter 5](#) for all available options.

## 2.1 Intel® Server Board M50CYP2SB Options

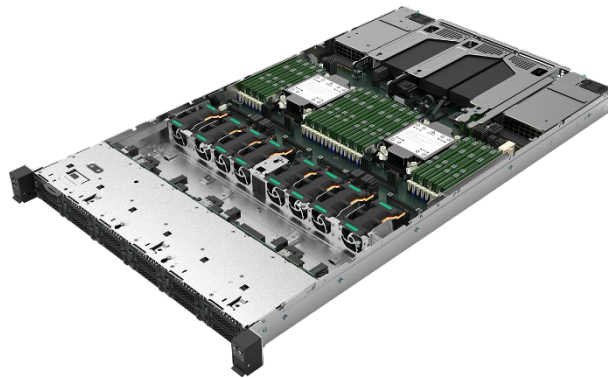
**Table 9. Intel® Server Board M50CYP2SB Options**

Product Image	Details	Description
	<p><b>Intel® Server Board M50CYP2SB1U</b></p> <p><b>iPC</b> M50CYP2SB1U  <b>MM#</b> 99A3TR  <b>UPC</b> 00735858471671  <b>EAN</b> 5032037210119  <b>MOQ</b> 1</p> <p><b>Product type</b> Server board only                      Building block/spare FRU</p> <p><b>Packaged gross wt.</b> 9.24 lbs.  <b>Un-packaged net wt.</b> 4.95 lbs. (1 board)</p>	<p>See <a href="#">Table 4</a> for the complete feature set. Unique board features include:</p> <ul style="list-style-type: none"> <li>• (8) – Server board SlimSAS connectors, four per processor</li> <li>• (10) – SATA 6 Gbps ports including two M.2 SSD ports</li> <li>• Fans                             <ul style="list-style-type: none"> <li>- Eight 8-pin fan connectors</li> <li>- CPU fan headers (one for each CPU)</li> </ul> </li> <li>• 32 DIMM slots, 16 per processor</li> <li>• Support for Intel Optane persistent memory 200 series</li> <li>• Intel Chipset C621A</li> <li>• Support for EVAC heat sink</li> </ul> <p><b>Box includes:</b> (1) server board</p> <p><b>Note:</b> All necessary mounting hardware, cabling, and shielding ship with the chassis and optional accessory kits.</p>
	<p><b>Intel® Server Board M50CYP2SBSTD</b></p> <p><b>iPC</b> M50CYP2SBSTD  <b>MM#</b> 99A5A0  <b>UPC</b> 00735858471664  <b>EAN</b> 5032037210102  <b>MOQ</b> 1</p> <p><b>Product type</b> Server board only                      Building block/spare FRU</p> <p><b>Packaged gross wt.</b> 40.2 lbs.  <b>Un-packaged net wt.</b> 24.75 lbs. (5 boards)</p>	<p>See <a href="#">Table 5</a> for the complete feature set. Unique board features include:</p> <ul style="list-style-type: none"> <li>• (8) – Server board SlimSAS connectors, four per processor</li> <li>• (10) – SATA 6 Gbps ports including two M.2 SSD ports</li> <li>• Fans                             <ul style="list-style-type: none"> <li>- Six 6-pin fan connectors</li> <li>- Eight 8-pin fan connectors</li> <li>- CPU fan headers (one for each CPU)</li> </ul> </li> <li>• 32 DIMM slots, 16 per processor</li> <li>• Support for Intel Optane persistent memory 200 series</li> <li>• Intel Chipset C621A</li> </ul> <p><b>Box includes:</b> (5) server boards</p> <p><b>Note:</b> All necessary mounting hardware, cabling, and shielding ship with the chassis and optional accessory kits.</p>

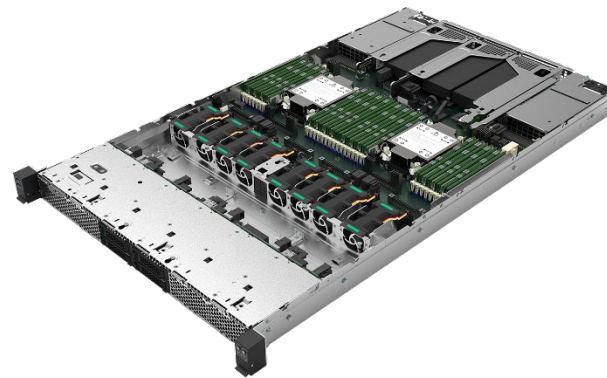
### 3. Server System Configurations

The Intel Server M50CYP Family includes several integrated server system options that include a 1U or 2U chassis with different hot swap drive bay configurations and a specific server board. At a minimum, building a functional server from one of these options requires the following:

- Rack mount kit – rails or fixed mount
- Power supply unit with power cords
- Processor(s)
- Memory
- Storage drives

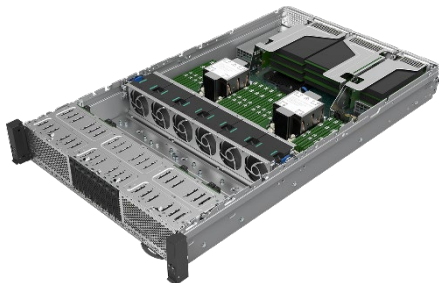


M50CYP1UR212



M50CYP1UR204

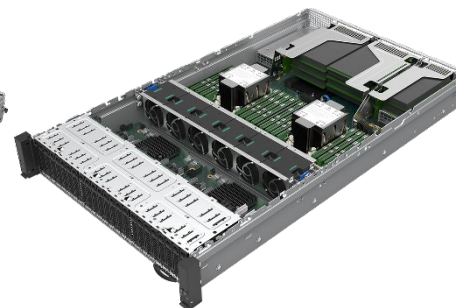
Figure 16. Intel® Server System M50CYP1UR Options



M50CYP2UR208



x16 Front Drive Bay System based on  
M50CYP2UR208



x24 Front Drive Bay System based on  
M50CYP2UR208



M50CYP2UR312

Figure 17. Intel® Server System M50CYP2UR Options

Optional Intel accessories that can be added include:

- Second power supply module to add power redundancy
- Intel® RAID support – PCIe add-in card or module and appropriate SAS data cable(s)
- Intel® RAID Maintenance Free Backup unit – Intel RAID backup accessory
- Intel Ethernet Network Adapter for OCP modules

See [Chapter 5](#) and [Chapter 6](#) for a full list of available options.

### 3.1 Intel® Server System M50CYP1UR – (1U Rack Mount System)

The product tables found in this section provide order code information and detailed descriptions for each available 1U L6 Intel Server System option. The lower sections of each table identify:

- **Included** – The ship along components of the specified chassis product code (product BOM).
- **Required items** – Hardware that must be installed to the base system to achieve basic functionality using the default system feature set. Required items are sold separately.
- **Optional accessories** – Some of the available accessories that can be installed to enhance the basic feature set of the server board/chassis. Optional accessories are sold separately. Additional accessories are in [Chapter 5](#).

---


**Note:** Items identified with an iPC (Intel Product Code) are orderable building block options, accessories, or spare Field Replaceable Units (FRUs). To provide the complete product bill of materials, the ship along components lists in each product table include items identified by description and by iPN (Intel Part Number). The iPN information is provided for reference only. These components are not orderable as spares or accessories.

---


This product family offers two levels of server system integration:

- **L6** – Integrated system: Chassis and server board, with no processors, memory, or storage devices.

**Table 10. Intel® Server System M50CYP1UR204 product Specifications and Configuration Requirements**

Intel® Server System M50CYP1UR204			
1U, Intel® Server Board M50CYP2SB1U, 4 x 2.5" SAS/SATA/NVMe SSD front mount drive bays			
	<p><b>iPC</b> M50CYP1UR204  <b>MM#</b> 99A3TX  <b>UPC</b> 00735858481793  <b>EAN</b> 5032037219013  <b>MOQ</b> 1</p>	<p><b>Product type</b> L6 integrated system  <b>Chassis form factor</b> 1U rack mount  <b>Packaged gross wt.</b> 21.15 kg  <b>Un-packaged net wt.</b> 14.18 kg  <b>Chassis dimensions</b> 781 x 438 x 43 mm (L x W x H)  <b>Package dimensions (outer box)</b> 994 x 592 x 300 mm (L x W x H)</p>	
Included	Required Items (sold separately)	Optional Accessories (sold separately)	
<p>(1) – 1U 2.5" Chassis with quick reference label affixed to top cover – iPN <b>K52548- xxx</b></p> <ul style="list-style-type: none"> <li>○ (1) – Quick reference label – iPN <b>M24177-xxx</b></li> </ul> <p>(4) – Hot-swap drive bays with drive mounting rails and blanks – iPN <b>K53035-xxx</b></p> <ul style="list-style-type: none"> <li>○ 2.5" SSD mounting rail with extraction lever – iPN <b>K71493- xxx</b></li> <li>○ 2.5" SSD Blank – iPN <b>K71491- xxx</b></li> </ul> <p>(1) – Front USB panel (left) with two USB ports – iPN <b>K48177- xxx</b></p> <ul style="list-style-type: none"> <li>○ (1) – <b>601 mm</b> USB 3.0/2.0 cable from server board to panel– iPN <b>K67061- xxx</b></li> </ul> <p>(1) – Front control panel (right) with control/status buttons – iPN <b>K48178- xxx</b></p> <ul style="list-style-type: none"> <li>○ (1) – <b>597.5 mm</b> front panel cable 26 pin – iPN <b>K67060- xxx</b></li> </ul> <p>(1) – 1U Server board – iPC <b>M50CYP2SB1U</b></p> <p>(1) – 4 x 2.5" Combo HSBP – iPC <b>CYPHSBP1204</b></p> <p>(1) – Cable wall Assembly (Left) – iPN <b>K72602- xxx</b></p> <p>(1) – Cable wall Assembly (Right) – iPN <b>K72603- xxx</b></p> <p>(1) – 1 Slot x16 LP PCIe riser card for Riser Slot #1 – iPC <b>CYP1URISER1STD</b></p> <p>(16) – DIMM Blank – iPN <b>K91058- xxx</b></p> <p>(1) – <b>445/720 mm</b> splitter power cable from server board to HSBP – iPN <b>K61358- xxx</b></p> <p>(1) – <b>350 mm</b> I<sup>2</sup>C cable from server board to HSBP – iPN <b>K63232- xxx</b></p> <p>(2) – EVAC heat sink– iPC <b>K67428- xxx</b></p> <p>(8) – Dual-rotor system fan – iPC <b>CYPFAN1UKIT</b></p> <p>(2) – Processor carrier clip – iPN <b>J98484- xxx</b></p> <p>(1) – Intel RAID Maintenance Free Backup Unit (RMFBU) bracket</p>	<ul style="list-style-type: none"> <li>• (1) or (2) Power Supply Unit(s), 1300 W, 1600 W – See <a href="#">Section 5.4</a></li> <li>• Power cord(s) – See <a href="#">Section 5.4</a></li> <li>• Rack mount kit – See <a href="#">Section 5.5</a></li> <li>• (1) or (2) 3<sup>rd</sup> Gen Intel Xeon Scalable processor</li> <li>• ECC DDR4 memory (RDIMM, LRDIMM, 3DS-RDIMM, or 3DS-LRDIMM)</li> </ul>	<p>The following is a partial list of supported accessories. See <a href="#">Chapters 5</a> and <a href="#">6</a> for all available accessory options.</p> <ul style="list-style-type: none"> <li>• Second AC power supply module to support power redundancy (1300 W (iPC <b>AXX1300TCRPS</b>) / 1600 W (iPC <b>AXX1600TCRPS</b>))</li> <li>• Intel Ethernet Network Adapter for OCP - See <a href="#">Section 5.2</a> for available options</li> <li>• Intel® 12G SAS RAID module and Intel RAID Maintenance Free Backup unit - See <a href="#">Section 5.3</a> for available options</li> <li>• NVMe data cable kit: – iPC <b>CYPCBLSL104KIT</b></li> <li>• SAS/SATA/NVMe – Cable selection is dependent on storage options. See <a href="#">Chapter 4</a> for available cable options</li> <li>• Standard Intel® VROC 7.5 Key – iPC <b>VROCSTANMOD</b></li> <li>• Storage drives</li> <li>• DDR4-compatible Intel Optane persistent memory 200 series module (requires an installed 3<sup>rd</sup> Gen Intel Xeon Scalable processor)</li> <li>• Raiser cards are sold separately, review available 1U options</li> </ul>	

**Table 11. Intel® Server System M50CYP1UR212 Specifications and Configuration Requirements**

Intel® Server System M50CYP1UR212			
1U, Intel® Server Board M50CYP2SB1U, 12 x 2.5" SAS/SATA/NVMe SSD front mount drive bays			
	<p><b>iPC</b> M50CYP1UR212  <b>MM#</b> 99A3TW  <b>UPC</b> 00735858481786  <b>EAN</b> 5032037219006  <b>MOQ</b> 1</p>	<p><b>Product type</b> L6 integrated system  <b>Chassis form factor</b> 1U rack mount  <b>Packaged gross wt.</b> 21.55 Kg  <b>Un-packaged net wt.</b> 14.58 Kg  <b>Chassis dimensions</b> 781 x 438 x 43 mm (L x W x H)  <b>Package dimensions</b> 994 x 592 x 300 mm (L x W x H)</p>	
Included	Required Items (sold separately)	Optional Accessories (sold separately)	
<p>(1) – 1U 2.5" Chassis with quick reference label affixed to top cover – iPN <b>K52548-xxx</b></p> <ul style="list-style-type: none"> <li>○ (1) – Quick reference label – <b>M24177_001</b></li> </ul> <p>(12) – Hot-swap drive bays with drive mounting rails and blanks – iPN <b>K53035-xxx</b></p> <ul style="list-style-type: none"> <li>○ 2.5" SSD mounting rail with extraction lever – iPN <b>K71493-xxx</b></li> <li>○ 2.5" SSD Blank – iPN <b>K71491-xxx</b></li> </ul> <p>(1) – Front USB panel (Left) with two USB ports – iPN <b>K48177-xxx</b></p> <ul style="list-style-type: none"> <li>○ (1) – <b>601 mm</b> USB 3.0/2.0 cable from server board to panel – iPN <b>K67061-xxx</b></li> </ul> <p>(1) – Front control panel (right) with control/status buttons – iPN <b>K48178-xxx</b></p> <ul style="list-style-type: none"> <li>○ (1) – <b>597.5 mm</b> front panel cable 26 pin – iPN <b>K67060-xxx</b></li> </ul> <p>(1) – 1U Server board – iPC <b>M50CYP2SB1U</b></p> <p>(1) – 12 x 2.5" Combo HSBP – iPC <b>CYPHSBP1212</b></p> <p>(1) – Cable wall Assembly (Left) – iPN <b>K72602-xxx</b></p> <p>(1) – Cable wall Assembly (Right) – iPN <b>K72603-xxx</b></p> <p>(1) – 1 Slot x16 LP PCIe riser card for Riser Slot #1 – iPC <b>CYP1URISER1STD</b></p> <p>(16) – DIMM Blank – iPN <b>K91058-xxx</b></p> <p>(1) – <b>445/720 mm</b> splitter power cable from server board to HSBP – iPN <b>K61358-xxx</b></p> <p>(1) – <b>250 mm</b> I<sup>2</sup>C cable from server board to HSBP iPN <b>K63231-xxx</b></p> <p>(2) – Standard 1U heat sink – iPC <b>K39908-xxx</b></p> <p>(8) – Dual-rotor system fan – iPC <b>CYPFAN1UKIT</b></p> <p>(2) – Processor Carrier Clip – iPN <b>J98484-xxx</b></p> <p>(1) – Intel RAID Maintenance Free Backup Unit (RMFBU) bracket</p>	<ul style="list-style-type: none"> <li>• (1) or (2) Power Supply Unit(s), 1300 W, 1600 W – See <a href="#">Section 5.4</a></li> <li>• Power cord(s) – See <a href="#">Section 5.4</a></li> <li>• Rack mount kit – See <a href="#">Section 5.5</a></li> <li>• (1) or (2) 3<sup>rd</sup> Gen Intel Xeon Scalable processor</li> <li>• ECC DDR4 memory (RDIMM, LRDIMM, 3DS-RDIMM, or 3DS-LRDIMM)</li> </ul>	<p>The following is a partial list of supported accessories. See <a href="#">Chapters 5</a> and <a href="#">6</a> for all available accessory options.</p> <ul style="list-style-type: none"> <li>• Second AC power supply unit to support power redundancy (1300 W PSU – iPC <b>AXX1300TCRPS</b>; 1600 W PSU – iPC <b>AXX1600TCRPS</b>)</li> <li>• Intel Ethernet Network Adapter for OCP - See <a href="#">Section 5.2</a> for available options</li> <li>• Intel 12G SAS RAID module and Intel RAID Maintenance Free Backup unit - See <a href="#">Section 5.3</a> for available options</li> <li>• SAS/SATA/NVMe – Cable selection is dependent on storage options. See <a href="#">Chapter 4</a> for available cable options.</li> <li>• NVMe data cable kit: – iPC <b>CYPCBLSL112KIT</b></li> <li>• Standard Intel VROC 7.5 Key – iPC <b>VROCSTANMOD</b></li> <li>• Storage drives</li> <li>• DDR4-compatible Intel Optane persistent memory 200 series module (requires an installed 3<sup>rd</sup> Gen Intel Xeon Scalable processor)</li> <li>• Slot PCIe NVMe riser card for Riser Slot #3 – iPC <b>CYPRISER3RTM</b></li> <li>• Raiser cards are sold separately, review available 1U options</li> </ul>	

## 3.2 Intel® Server System M50CYP2UR – (2U Rack Mount System)

The product tables found in this section provide order code information and detailed descriptions for the specified L6 Integrated 2U Intel Server System. The lower sections of each table identify:


- **Included** – The ship along components of the specified chassis product code – (product BOM)
- **Required Items** – The options required to be installed to the base system to achieve basic functionality using the default system feature set
- **Optional Accessories** – Some of the available accessories that can be installed to enhance the basic feature set of the server board / chassis. Additional accessories are in [Chapter 4](#).

---


**Notes:**

- Each required item and optional accessory are sold separately for the specified Intel L6 server system.
  - Items identified as iPC (Intel Product Code) are an orderable building block option, accessory, or spare FRU.
  - To provide the complete product bill of materials, the ship along components list in each product table will include items identified by description and by iPN (Intel Part Number). The iPN information is provided for reference only. These components are not orderable as a spare or accessory.
  - L6 – Integrated system: Chassis and server board, with no processors, memory, or storage devices.
-

**Table 12. Intel® Server System M50CYP2UR208 Specifications and Configuration Requirements**

Intel® Server System M50CYP2UR208			
2U, Intel® Server Board M50CYP2SBSTD, 8 x 2.5" SSD SAS/SATA front mount drives			
	<p><b>iPC</b> M50CYP2UR208  <b>MM#</b> 99A3TT  <b>UPC</b> 00735858481762  <b>EAN</b> 5032037218986  <b>MOQ</b> 1</p>	<p><b>Product type</b> L6 integrated system  <b>Chassis form factor</b> 2U rack mount  <b>Packaged gross wt.</b> 24.36Kg  <b>Un-packaged net wt.</b> 16.76Kg  <b>Chassis dimensions</b> 770 x 446 x 87 mm (L x W x H)  <b>Package dimensions</b> 994 x 592 x 300 mm (L x W x H)</p>	
Included	Required Items (sold separately)	Optional Accessories (sold separately)	
<p>(1) – 2U 2.5" Chassis with Quick Reference Label affixed to top cover – iPN <b>K52544-xxx</b></p> <ul style="list-style-type: none"> <li>○ (1) – Quick reference label – iPN <b>M24213-xxx</b></li> </ul> <p>(8) – 2.5" hot-swap drive bays with drive mounting rails and blanks – iPN <b>K53035-xxx</b>. Includes:</p> <ul style="list-style-type: none"> <li>○ 2.5" SSD mounting rail with lever – iPN <b>K71493-xxx</b></li> <li>○ 2.5" SSD Blank – iPN <b>K71491-xxx</b></li> </ul> <p>(1) – Front I/O assembly w/ two USB ports, left side – iPN <b>K48177-xxx</b></p> <ul style="list-style-type: none"> <li>○ <b>601 mm</b> USB 3.0/2.0 cable, server board to front I/O assembly, – iPN <b>K67061-xxx</b></li> </ul> <p>(1) – Front control panel (right) with control/status buttons – iPN <b>K48178-xxx</b></p> <ul style="list-style-type: none"> <li>○ (1) – <b>598.5 mm</b> front panel cable, 26 pin – iPN <b>K67059-xxx</b></li> </ul> <p>(1) – 2U Server Board – iPC <b>M50CYP2SBSTD</b>  (1) – 8 x 2.5" Combo HSBP – iPC <b>CYPHSBP2208</b>  (16) – DIMM blanks – iPN <b>K91058-xxx</b>  (1) – <b>455/565/720 mm</b> splitter power cable, server board to HSBPs (1, 2, and 3) 2x6 pin to three 2x2 pin – iPN <b>K62572-xxx</b>  (1) – <b>350 mm</b> I<sup>2</sup>C cable, server board to HSBP– iPN <b>K63232-xxx</b>  (1) – Standard 2U air duct (for 2U-Tall HS) – iPN <b>K52571-xxx</b>  (6) – Single-rotor system fan – iPC <b>CYPFAN2UKIT</b>  (2) – Processor carrier clip – iPN <b>J98484-xxx</b>  (2) – Intel RAID Maintenance Free Backup Unit (RMFBU) bracket</p>	<ul style="list-style-type: none"> <li>• (1) or (2) Power Supply Unit(s), 1300 W, 1600 W, or 2100 W – See <a href="#">Section 5.4</a></li> <li>• Power cord(s) – See <a href="#">Section 5.4</a></li> <li>• Rack mount kit – See <a href="#">Section 5.5</a></li> <li>• (1) or (2) 3<sup>rd</sup> Gen Intel Xeon processor Scalable family</li> <li>• ECC DDR4 memory (RDIMM, LRDIMM, 3DS-RDIMM, or 3DS-LRDIMM)</li> <li>• (1) or (2) Standard 1U or 2U heat sink – See <a href="#">Chapter 6</a></li> </ul>	<p>The following is a partial list of supported accessories. See <a href="#">Chapters 5 and 6</a> for all available accessory options.</p> <ul style="list-style-type: none"> <li>• Second AC power supply unit to support power redundancy (1300 W PSU - iPC <b>AXX1300TCRPS</b>; 1600 W PSU - iPC <b>AXX1600TCRPS</b>, 2100 W - iPC <b>FCXX2100CRPS</b>)</li> <li>• Intel Ethernet Network Adapter for OCP - See <a href="#">Section 5.2</a> for available options</li> <li>• Intel 12G SAS RAID module and Intel RAID Maintenance Free Backup unit. See <a href="#">Section 5.3</a> for available options</li> <li>• SAS Data cable kits– iPC <b>CYPCBLSLINTKIT</b> and <b>CYPCBLHDHDXXX2</b></li> <li>• SAS/SATA/NVMe – Cable selection is dependent on storage options. See <a href="#">Chapter 4</a> for available cable options.</li> <li>• Standard Intel VROC 7.5 Key– iPC <b>VROCSTANMOD</b></li> <li>• Storage drives</li> <li>• DDR4-compatible Intel Optane persistent memory 200 series module (requires an installed 3<sup>rd</sup> Gen Intel Xeon Scalable processor)</li> <li>• Slot PCIe NVMe riser card for Riser Slot #3 – iPC <b>CYPRISER3RTM</b></li> <li>• Raiser cards are sold separately, review available 2U options</li> </ul>	

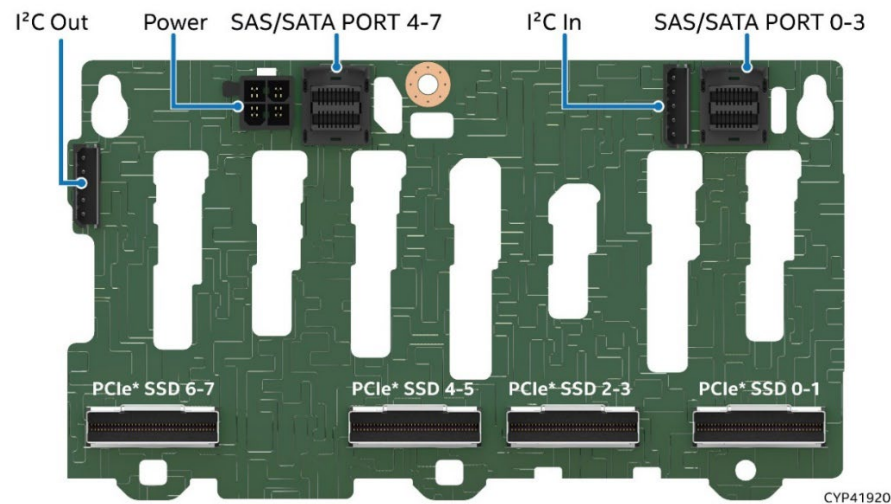
**Table 13. Intel® Server System M50CYP2UR312 Specifications and Configuration Requirements**

Intel® Server System M50CYP2UR312		
2U, Intel® Server Board M50CYP2SBSTD, 12 x 3.5" SAS/SATA /NVMe* front mount drives		
	<p><b>iPC</b> M50CYP2UR312  <b>MM#</b> 99A3TV  <b>UPC</b> 00735858481779  <b>EAN</b> 5032037218993  <b>MOQ</b> 1</p>	<p><b>Product type</b> L6 integrated system  <b>Chassis form factor</b> 2U rack mount  <b>Packaged gross wt.</b> 25.46Kg  <b>Un-packaged net wt.</b> 17.86Kg  <b>Chassis dimensions</b> 712 x 439 x 89 mm (L x W x H)  <b>Package dimensions</b> 983 x 577 x 260 mm (L x W x H)</p>
Included	Required Items (sold separately)	Optional Accessories (sold separately)
<p>(1) – Chassis with Quick Reference Label affixed to top cover – iPN <b>K52545-xxx</b></p> <ul style="list-style-type: none"> <li>o (1) – Quick reference label – iPN <b>M24213-xxx</b></li> </ul> <p>(1) – 2U 3.5" Chassis – iPN <b>K52545-xxx</b></p> <p>(1) – Front I/O assembly w/ two USB ports, left side – iPN <b>K48177-xxx</b></p> <ul style="list-style-type: none"> <li>o (1) <b>601 mm</b> USB 3.0/2.0 cable, server board to front I/O assembly, – iPN <b>K67061-xxx</b></li> </ul> <p>(1) – Front control panel (right) with control/status buttons – iPN <b>K48178-xxx</b></p> <ul style="list-style-type: none"> <li>o (1) <b>598.5 mm</b> front control panel cable, 26 pin – iPN <b>K67059-xxx</b></li> </ul> <p>(1) – 2U Server Board – iPC <b>M50CYP2SBSTD</b></p> <p>(1) – 12 x 3.5 Combo HSBP – iPC <b>CYPHSBP2312</b></p> <p>(12) – 3.5" HDD/SSD drive carriers 3.5" – iPN <b>J36447-xxx</b></p> <p>(16) – DIMM Blank – iPN <b>K91058-xxx</b></p> <p>(1) – <b>425/660 mm</b> splitter power cable, server board connector to 3.5" HSBP power connectors – iPN <b>K67596-xxx</b></p> <p>(1) – <b>250 mm</b> I<sup>2</sup>C cable, server board to HSBP – iPN <b>K63231-xxx</b></p> <p>(1) – Standard air duct for 2U – iPN <b>K52571-xxx</b></p> <p>(6) – Single-rotor system fan – iPC <b>CYPFAN2UKIT</b></p> <p>(2) – Processor carrier clip – iPN <b>J98484-xxx</b></p> <p>(2) – Intel RAID Maintenance Free Backup Unit (RMFBU) bracket</p>	<ul style="list-style-type: none"> <li>• (1) or (2) Power Supply Unit(s), 1300 W, 1600 W, or 2100 W – See <a href="#">Section 5.4</a></li> <li>• Power cord(s) – See <a href="#">Section 5.4</a></li> <li>• Rack mount kit – See <a href="#">Section 5.5</a></li> <li>• (1) or (2) 3<sup>rd</sup> Gen Intel Xeon processor Scalable family</li> <li>• ECC DDR4 memory (RDIMM, LRDIMM, 3DS-RDIMM, or 3DS-LRDIMM)</li> <li>• (1) or (2) Standard 1U or 2U heat sink – See <a href="#">Chapter 6</a></li> </ul>	<p>The following is a partial list of supported accessories. See <a href="#">Chapters 5</a> and <a href="#">6</a> for all available accessory options.</p> <ul style="list-style-type: none"> <li>• Second AC power supply unit to support power redundancy (1300 W PSU - iPC <b>AXX1300TCRPS</b>; 1600 W PSU - iPC <b>AXX1600TCRPS</b>, 2100 - iPC <b>FCXX2100CRPS</b>)</li> <li>• Intel Ethernet Network Adapter for OCP. See <a href="#">Section 5.2</a> for available options</li> <li>• Intel 12G SAS RAID module and Intel RAID Maintenance Free Backup unit. See <a href="#">Section 5.3</a> for available options</li> <li>• SAS Data cable kits – iPC <b>CYPCBLSLINTKIT</b> and <b>CYPCBLHDHDXXX2</b></li> <li>• SAS/SATA/NVMe – Cable selection is dependent on storage options. See <a href="#">Chapter 4</a> for available cable options.</li> <li>• Standard Intel VROC 7.5 Key – iPC – <b>VROCSTANMOD</b></li> <li>• Storage drives</li> <li>• DDR4-compatible Intel Optane persistent memory 200 series module (requires an installed 3<sup>rd</sup> Gen Intel Xeon Scalable processor)</li> <li>• 2-Slot PCIe NVMe riser card for Riser Slot #3 – iPC <b>CYPRISER3RTM</b></li> <li>• Raiser cards are sold separately, review available 2U options</li> </ul>

## 4. SAS / SATA / NVMe\* Data Cable Guide

SAS/SATA/NVMe data cables are not included with any of the L3 or L6 SKUs. They must be ordered separately to match the desired system configuration.

Images from [Figure 18](#) through [Figure 21](#) show the back side of the 1U and 2U backplane options. The backside of each installed backplane has a four-port SFF-8643 Mini-SAS HD data connector for each set of four SAS/SATA drives. Each port supports one SAS/SATA drive. The back side of each backplane also includes PCIe NVMe SlimSAS connectors to support PCIe NVMe drives. Drive numbers in the cable configuration tables match the specific cable connectors found on the given backplane.



**Figure 18. 2U 8 x 2.5" SAS / SATA / NVMe\* Hot-Swap Backplane – Back Side**

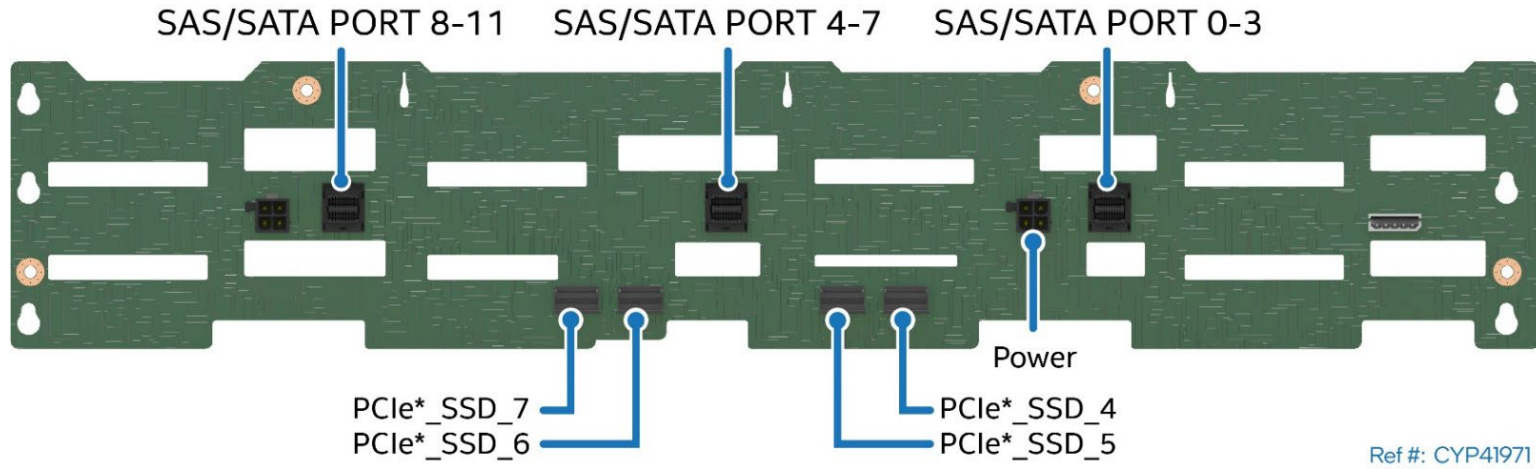


Figure 19. 2U 12 x 3.5" HSBP Connector Identification – Back Side

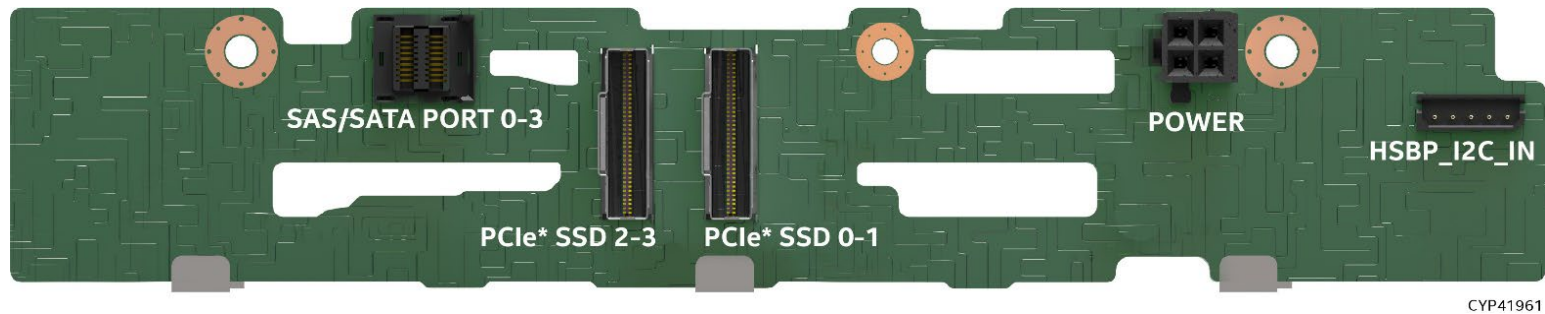


Figure 20. 1U 4 x 2.5" SAS / SATA / NVMe\* Hot Swap Backplane – Back Side

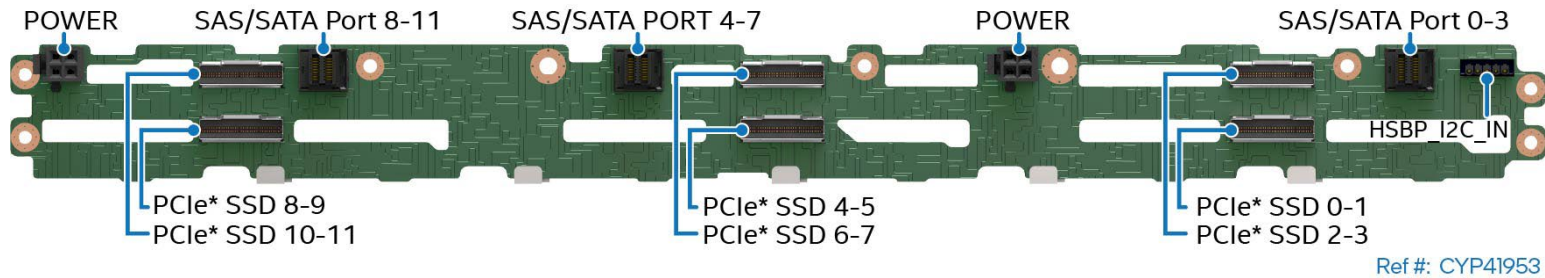



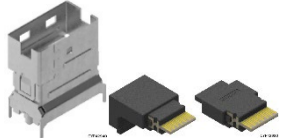
Figure 21. 1U 12 x 2.5" SAS / SATA / NVMe\* Hot Swap Backplane – Back Side

## 4.1 Data Cable Connector Types

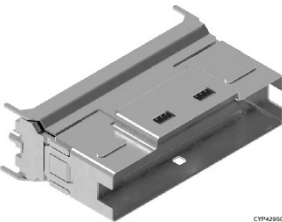
**Table 14. Multiport Mini-SAS HD Cable Connectors**

Image	Description
	<p><b>SFF-8643 (Mini-SAS HD)</b>                      Support for up to 12 Gb/Sec SAS                      Where it is used:</p> <ul style="list-style-type: none"> <li>• On the server board – (2) 4-port SATA connectors (SATA 0–3 &amp; SATA 4–7)</li> <li>• All 12 Gb/sec SAS capable hot swap backplanes</li> <li>• All 12 Gb/sec SAS RAID Controllers</li> <li>• 12 Gb/sec SAS Expander Card</li> </ul>

**Table 15. x4 PCIe\* SlimSAS Cable Connectors**

Image	Description
	<p><b>x4 SlimSAS connectors</b>                      Support for PCIe NVMe SFF (2.5") SSDs                      Where it is used:</p> <ul style="list-style-type: none"> <li>• On the server board – 8 connectors (4 per processor)</li> <li>• On 2U 3.5" SAS/SATA/NVMe backplane</li> </ul>

**Table 16. x8 PCIe\* SlimSAS Cable Connectors**

Image	Description
	<p><b>x8 SlimSAS connector</b>                      Support for PCIe NVMe SFF (2.5") SSDs                      Where it is used:</p> <p><b>HSBP Options:</b></p> <ul style="list-style-type: none"> <li>• 4 x 2.5" SAS/SATA/NVMe hot swap backplane</li> <li>• 12 x 2.5" SAS/SATA/NVMe hot swap backplane</li> <li>• 8 x 2.5" Drive SAS/SATA/NVMe Combo backplane</li> </ul> <p><b>Riser Card Options:</b></p> <ul style="list-style-type: none"> <li>• Interposer riser card option – iPC <b>CYP1URISER2KIT</b></li> <li>• 1U/2U PCIe NVMe riser card, Riser Slot #3 – iPC <b>CYPRISER3RTM</b></li> <li>• PCIe NVMe riser card for Riser Slot #1 – iPC <b>CYP2URISER3RTM</b></li> </ul>

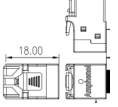

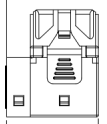
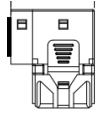


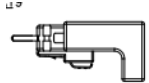
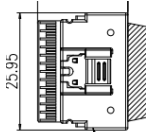
## 4.2 1U / 2U Server System SAS / SATA / NVMe\* Cable Kits

The following table identifies the different data cable connector types and the identifiers used in the cable kit product codes.

Product tables in this section reference specific SAS/SATA and NVMe cables. Different cable kits are offered to support specific system configurations. The product order code for each cable kit is made up of a string of letters and numbers to identify the type of cable included in the kit.

The following table identifies the different data cable connector types and the identifiers used in the cable kit product codes.

**Table 17.Data Cable Connector Identification**

Connector Image	Cable Connector Type	Description
	RA Mini-SAS HD	Right angle SFF-8643 (Mini-SAS HD) connector
	VT Mini-SAS HD	Straight/Vertical SFF-8643 Mini-SAS HD connector
	RS Mini-SAS HD	Right side SFF-8643 Mini-SAS HD connector
	LS Mini-SAS HD	Left side SFF-8643 Mini-SAS HD connector
	VT X4 SlimSAS	Straight/Vertical X4 SlimSAS PCIe NVMe connector
	RA X4 SlimSAS	Right angle X4 SlimSAS PCIe NVMe connector
	RRA X4 SlimSAS	Reversed right angle X4 SlimSAS PCIe NVMe connector
	VT X8 SlimSAS	X8 SlimSAS PCIe NVMe connector

### 4.2.1 Cable Kit Product Code Decoder Examples

Abbreviation	Description
<b>CBL</b>	Cable
<b>COMM</b>	Common Cables
<b>Kit</b>	Data cable kit
<b>CYP</b>	Intel Server M50CYP Family
<b>INT</b>	SAS Interposer
<b>RT</b>	Riser with re-timer
<b>HD</b>	Mini-SAS HD Connector
<b>SL</b>	SlimSAS connector

#### SAS/SATA Data Cable Example – iPC **CYPCBLHDHDXXX**

- **CYPCBL** – Identifies a M50CYP accessory cable kit
- **HD** – Identifies that both ends of the cable are Mini-SAS HD SFF-8643 type connector

#### NVMe SlimSAS Cable Example – iPC **CYPCBLSL104KIT**

- **CYPCBL** – Identifies a M50CYP accessory cable kit
- **SL** – Identifies that both ends of cable have SlimSAS connector type
- **104** – Identifies that the cable kit is for 1U x4 front drive bay system

## 4.2.2 Cable Kit Order Information

**Note:** A splitter cable is a cable that has two or more connectors on one end.

Table 18. SAS/SATA/NVMe\* Data Cable Kit Description and Order Information


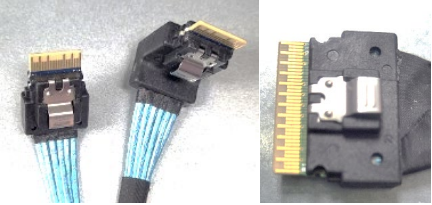
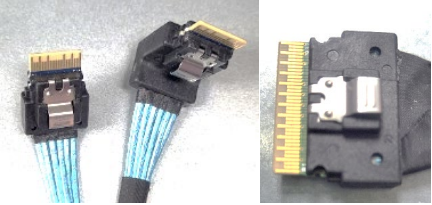
Image	Details	Description
	<p> <b>iPC</b> CYPBLSLINTKIT  <b>MM#</b> 99AJF4  <b>UPC</b> 00735858475129  <b>EAN</b> 5032037213073  <b>MOQ</b> 1         </p>	<p>Used in 1U / 2U systems as spare or accessory.</p> <p><b>Kit Includes:</b></p> <ul style="list-style-type: none"> <li>(1) – <b>125/355 mm</b> splitter cable, Power cable connects server board 12 V power connector to Midplane card / Interposer card power connector.</li> </ul> <p><b>Note:</b> System does not support both SAS Interposer card and Midplane card at the same time.</p> <ul style="list-style-type: none"> <li>(1) – <b>610 mm</b> cable, I<sup>2</sup>C (P+S) server board (rear) to SAS Interposer card (10 Pin to 10 Pin)</li> <li>(1) – <b>250 mm</b> cable, SB CPU0 x4 SlimSAS A or CPU1 x4 SlimSAS D to SAS Interposer card x4 SlimSAS A, VT -&gt; RA</li> <li>(1) – <b>250 mm</b> cable, SB CPU0 x4 SlimSAS B or CPU1 x4 SlimSAS C to SAS Interposer card x4 SlimSAS B, RRA -&gt;RA</li> </ul>
	<p> <b>iPC</b> CYPBLSL208KIT  <b>MM#</b> 99A5A3  <b>UPC</b> 00735858475143  <b>EAN</b> 5032037213097  <b>MOQ</b> 1         </p>	<p>Used in 2U M50CYP2UR208 system to enable PCIe NVMe storage.</p> <p><b>Kit Includes:</b></p> <ul style="list-style-type: none"> <li>(1) – <b>240/260 mm</b> splitter cable, connects server board CPU0 x4 SlimSAS A and B (VT) to HSBP x8 SlimSAS SSD0-1 (VT)</li> <li>(1) – <b>330/310 mm</b> splitter cable, connects server board CPU0 x4 SlimSAS C and D (VT) to HSBP x8 SlimSAS SSD2-3 (VT)</li> <li>(1) – <b>235/215 mm</b> splitter cable, connects server board CPU1 x4 SlimSAS C and D (VT) to HSBP x8 SlimSAS SSD6-7 (VT)</li> <li>(1) – <b>370/390 mm</b> splitter cable, connects server board CPU1 x4 SlimSAS A and B (VT) to HSBP x8 SlimSAS SSD4-5 (VT)</li> </ul>
	<p> <b>iPC</b> CYPBLSL216KIT  <b>MM#</b> 99A5A4  <b>UPC</b> 00735858475150  <b>EAN</b> 5032037213103  <b>MOQ</b> 1         </p>	<p>Used in 2U M50CYP2UR x16 front drive bay system to enable PCIe NVMe storage.</p> <p><b>Kit Includes:</b></p> <ul style="list-style-type: none"> <li>(1)– <b>275/255 mm</b> splitter cable, connects server board CPU0 x4 SlimSAS C and D (VT) to HSBP (left) x8 SlimSAS SSD6-7 (VT)</li> <li>(1)– <b>305/325 mm</b> splitter cable, connecting server board CPU0 x4 SlimSAS A and B (VT) to HSBP (left) x8 SlimSAS SSD4-5 (VT)</li> <li>(1)– <b>360/340 mm</b> splitter cable, connects server board CPU1 x4 SlimSAS C and D (VT) to HSBP (right) x8 SlimSAS SSD14-15 (VT)</li> <li>(1)– <b>240/260 mm</b> splitter cable, connects server board CPU1 x4 SlimSAS A and B (VT) to HSBP (right) x8 SlimSAS SSD12-13 (VT)</li> </ul>

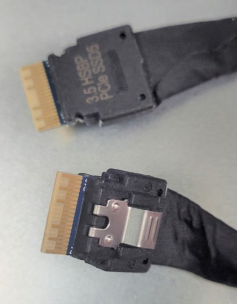

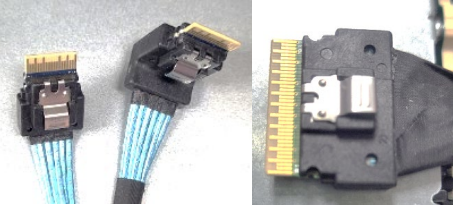
Image	Details	Description
	<p><b>iPC</b> CYPCLSLMIDPIN  <b>MM#</b> 99AJF6  <b>UPC</b> 00735858475167  <b>EAN</b> 5032037213110  <b>MOQ</b> 1</p>	<p>Used in 2U 2.5" systems with greater than 16 PCIe NVMe drives in the front bay.</p> <p><b>Kit Includes:</b></p> <ul style="list-style-type: none"> <li>(4) – <b>160 mm</b> cable, connects server board CPU0 or CPU1 x4 SlimSAS connector to Midplane card x4 SlimSAS connector.</li> </ul> <p><b>Note:</b> To support 24 NVMe drives in front bay, need to order two Midplane cards and 2 sets of this cable kit.</p>
	<p><b>iPC</b> CYPCLSLMIDPOUT  <b>MM#</b> 99AJF7  <b>UPC</b> 00735858475174  <b>EAN</b> 5032037213127  <b>MOQ</b> 1</p>	<p>Used in 2U 2.5" systems with greater than 16 PCIe NVMe drives in front bay.</p> <p><b>Kit Includes:</b></p> <ul style="list-style-type: none"> <li>(1) – <b>110 mm</b> cable, connects Midplane card x8 SlimSAS connector to HSBP x8 SlimSAS connector. One cable per connection.</li> </ul> <p><b>Note:</b> To support 24 NVMe drives in front bay, need to order two Midplane cards and 12 sets of this cable kit.</p>
	<p><b>iPC</b> CYPCLSL204KIT  <b>MM#</b> 99A5A7  <b>UPC</b> 00735858475181  <b>EAN</b> 5032037213134  <b>MOQ</b> 1</p>	<p>Used in 2U 3.5" systems (M50CYP2UR312) to support PCIe NVMe drives in front drive bay</p> <p><b>Included in cable kit: CYPCLSL204KIT</b></p> <ul style="list-style-type: none"> <li>(1) – <b>200 mm</b> cable, connects server board CPU0 x4 SlimSAS B connector to HSBP x4 SlimSAS SSD5 connector</li> <li>(1) – <b>180 mm</b> cable, connects server board CPU1 4x SlimSAS B connector to HSBP x4 SlimSAS SSD7 connector</li> <li>(1) – <b>175 mm</b> cable, connects server board CPU0 x4 SlimSAS A connector to HSBP x4 SlimSAS SSD4 connector</li> <li>(1) – <b>205 mm</b> cable, connects server board CPU1 x4 SlimSAS A connector on HSBP x4 SlimSAS SSD6 connector</li> </ul>
	<p><b>iPC</b> CYPCLSL112KIT  <b>MM#</b> 99A5A8  <b>UPC</b> 00735858475198  <b>EAN</b> 5032037213141  <b>MOQ</b> 1</p>	<p>Used in 1U 12 x 2.5" system (M50CYP1UR212) to support PCIe NVMe drives in front drive bay</p> <p><b>Kit Includes:</b></p> <ul style="list-style-type: none"> <li>(1) – <b>412/420 mm</b> splitter cable, connects server board CPU0 x4 SlimSAS A and B connectors (RRA) to HSBP x8 SlimSAS SSD0-1 connector (VT)</li> <li>(1) – <b>400/392 mm</b> splitter cable, connects server board CPU1 x4 SlimSAS C (RRA) and D connectors to HSBP x8 SlimSAS SSD10-11 connector (VT)</li> <li>(1) – <b>350/342 mm</b> splitter cable, connects server board CPU0 x4 SlimSAS C (RRA) and D connectors to HSBP x8 SlimSAS SSD2-3 connector (VT)</li> <li>(1) – <b>312/320 mm</b> splitter cable, connects server board CPU1 x4 SlimSAS A and B connectors (RRA) to HSBP x8 SlimSAS SSD8-9 connector (VT)</li> </ul>

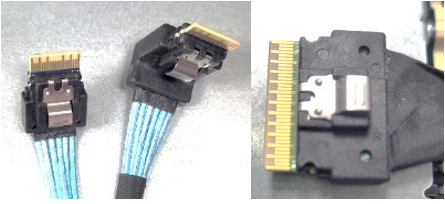



Image	Details	Description
	<p><b>iPC</b> CYPCLSL104KIT  <b>MM#</b> 99A5A9  <b>UPC</b> 00735858475204  <b>EAN</b> 5032037213158  <b>MOQ</b> 2</p>	<p>Used in 1U 4 x 2.5" system (M50CYP1UR204) to support PCIe NVMe drives in front drive bay</p> <p><b>Kit Includes:</b></p> <ul style="list-style-type: none"> <li>(1) – <b>412/420 mm</b> splitter cable, connects server board CPU0 x4 SlimSAS A and B connectors (RRA) to HSBP x8 SlimSAS PCIe SSD 0–1 connector (VT)</li> </ul> <p><b>Note:</b> Need to order additional cable kit to connect server board CPU1 x4 SlimSAS A and B connectors (RRA) to HSBP x8 SlimSAS PCIe SSD 2–3 connector (VT)</p>
	<p><b>iPC</b> CYPCLSLRTRKIT  <b>MM#</b> 99A67F  <b>UPC</b> 00735858475211  <b>EAN</b> 5032037213165  <b>MOQ</b> 1</p>	<p>Used in 1U/2U systems supporting additional NVMe drives in front drive bay.</p> <p><b>Kit Includes:</b></p> <p>(2) – <b>660 mm</b> cables</p> <p>Usage in 2U systems</p> <ul style="list-style-type: none"> <li>(1) – <b>660 mm</b> cable, connects Riser #1 NVMe riser card x8 SlimSAS PCIe_SSD_0-1 connector to HSBP x8 SlimSAS SSD0-1 connector</li> <li>(1) – <b>660 mm</b> cable, connects Riser #1 NVMe riser card x8 SlimSAS PCIe_SSD_2-3 connector to HSBP x8 SlimSAS SSD2-3 connector</li> </ul> <p>Usage in 1U x 12 front drive bay systems</p> <ul style="list-style-type: none"> <li>(1) – <b>660 mm</b> cable, connects Riser #3 NVMe riser card x8 SlimSAS PCIe_SSD_0-1 connector to HSBP x8 SlimSAS SSD4-5 or SSD6-7 or SSD8-9 or SSD10-11 connectors</li> <li>(1) – <b>660 mm</b> cable, connects Riser #3 NVMe riser card x8 SlimSAS PCIe_SSD_2-3 connector to HSBP x8 SlimSAS SSD4-5 or SSD6-7 or SSD8-9 or SSD10-11 connectors</li> </ul>
	<p><b>iPC</b> CYPCLSLSLX8  <b>MM#</b> 99AJR4  <b>UPC</b> 00735858487528  <b>EAN</b> 5032037224109  <b>MOQ</b> 1</p>	<p>Used in 1U/2U systems to support additional NVMe drives in front drive bay.</p> <p><b>Kit Includes:</b></p> <ul style="list-style-type: none"> <li>(1) – <b>860 mm</b> cable, connects add-in card x8 SlimSAS connector to HSBP x8 SlimSAS connector</li> <li>(1) – <b>1 m</b> cable, connects add-in card x8 SlimSAS connector to HSBP x8 SlimSAS connector</li> </ul>
	<p><b>iPC</b> CYPCLHDHDX1  <b>MM#</b> 99AJF8  <b>UPC</b> 00735858475228  <b>EAN</b> 5032037213172  <b>MOQ</b> 1</p>	<p>Used in 1U/2U systems to support SAS/SATA drives in front drive bay. Usage varies depending on front drive bay configuration.</p> <p><b>Kit Includes:</b></p> <ul style="list-style-type: none"> <li>(1) – <b>640 mm</b> cable, connects add-in card Mini-SAS HD connector to HSBP Mini-SAS HD connector (VT to VT)</li> <li>(1) – <b>840 mm</b> cable, connects add-in card Mini-SAS HD connector to HSBP Mini-SAS HD connector (RA to VT)</li> <li>(1) – <b>930 mm</b> cable, connects add-in card or server board Mini-SAS HD connector to HSBP Mini-SAS HD connector (RA to VT)</li> </ul>

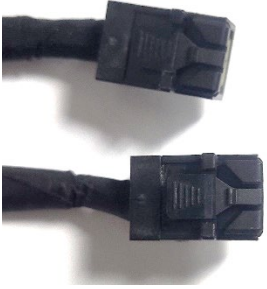
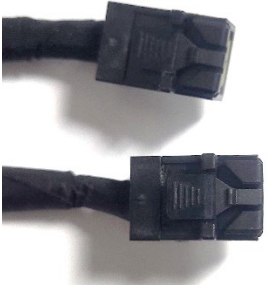
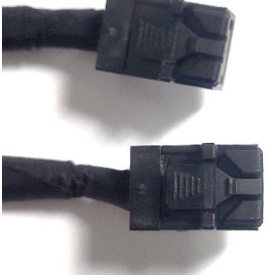
Image	Details	Description
	<p> <b>iPC</b> CYPCLHDHDX2  <b>MM#</b> 99AJF9  <b>UPC</b> 00735858475235  <b>EAN</b> 5032037213189  <b>MOQ</b> 1                 </p>	<p>Used in 1U/2U x8 systems to support SAS/SATA drives in front drive bay.</p> <p><b>Kit Includes:</b></p> <ul style="list-style-type: none"> <li>• (1) – <b>180 mm</b> cable, connects SAS ROC module Mini-SAS HD connector to HSBP Mini-SAS HD Port 0–3 connector</li> <li>• (1) – <b>250 mm</b> cable, connects SAS ROC module Mini-SAS HD connector to HSBP Mini-SAS HD Port 4–7 connector</li> </ul>
	<p> <b>iPC</b> CYPCLHDHDX  <b>MM#</b> 99AJFA  <b>UPC</b> 00735858475242  <b>EAN</b> 5032037213196  <b>MOQ</b> 1                 </p>	<p>Used in 2U systems to provide additional support for SAS/SATA drives in front drive bay using SAS Expander card.</p> <p><b>Note:</b> For 16 or more SAS/SATA drives in the front drive bay, a SAS Expander card is needed.</p> <p><b>Kit Includes:</b></p> <ul style="list-style-type: none"> <li>• (1) – <b>540 mm</b> cable, connects SAS ROC module Mini-SAS HD output connector to SAS Expander card Mini-SAS HD G or H or I connector</li> </ul>
	<p> <b>iPC</b> CYPCLMEZKIT  <b>MM#</b> 99AJFC  <b>UPC</b> 00735858475136  <b>EAN</b> 5032037213080  <b>MOQ</b> 1                 </p>	<p>Used in 1U/2U systems to connect ROC modules.</p> <p><b>Kit Includes:</b></p> <ul style="list-style-type: none"> <li>• (1) – <b>385 mm</b> cable, connects ROC module Mini-SAS HD connector (LS) to HSBP Mini-SAS HD connector (VT)</li> <li>• (2) – <b>140 mm</b> cable, connects ROC module Mini-SAS HD connector (RS) to HSBP Mini-SAS HD connector (RA)</li> </ul>


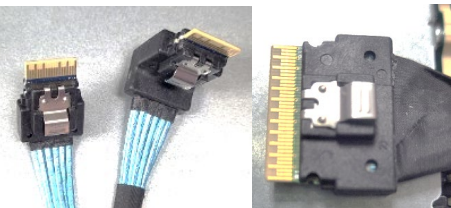
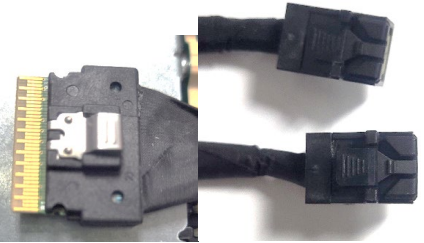
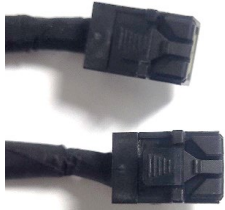
Image	Details	Description
	<p><b>iPC</b> CYPBLSLRVx2OUT  <b>MM#</b> 99AMXT  <b>UPC</b> 00735858497329  <b>EAN</b> 5032037232463  <b>MOQ</b> 1</p>	<p>Used in M50CYP2UR x24 system to connect Midplane card to HSBP for front NVMe drive support.</p> <p><b>Kit Includes:</b></p> <ul style="list-style-type: none"> <li>• (1) – <b>110 mm</b> cable, Midplane card x8 SlimSAS connector to HSBP 2 x8 SlimSAS connectors</li> <li>• (1) – <b>160 mm</b> cable, Midplane card x8 SlimSAS connector to HSBP 2 x8 SlimSAS connectors</li> <li>• (2) – <b>200 mm</b> cable, Midplane card x8 SlimSAS connector to HSBP 2 x8 SlimSAS connectors</li> <li>• (1) – <b>260 mm</b> cable, Midplane card x8 SlimSAS connector to HSBP 2 x8 SlimSAS connectors</li> <li>• (1) – <b>340 mm</b> cable, Midplane card x8 SlimSAS connector to HSBP 2 x8 SlimSAS connectors</li> </ul>
	<p><b>iPC</b> CYPBLSLSSRIS  <b>MM#</b> 99AMXV  <b>UPC</b> 00735858497336  <b>EAN</b> 5032037232470  <b>MOQ</b> 1</p>	<p>Used in 1U/2U systems to connect tri-mode RAID add-in card to HSBP for front NVMe drive support.</p> <p><b>Kit Includes:</b></p> <ul style="list-style-type: none"> <li>• (1) – <b>860 mm</b> cable, add-in card x8 SlimSAS connector to HSBP 2 x8 SlimSAS connectors</li> <li>• (1) – <b>760 mm</b> cable, add-in card x8 SlimSAS connector to HSBP 2 x8 SlimSAS connectors</li> </ul>
	<p><b>iPC</b> CYPBLSLAIC2RVL  <b>MM#</b> 99C79H  <b>UPC</b> 00735858531245  <b>EAN</b> 5032037262828  <b>MOQ</b> 1</p>	<p>Used in M50CYP2UR x24 system to connect tri-mode RAID add-in card to Midplane card for front NVMe drive support.</p> <p><b>Kit Includes:</b></p> <ul style="list-style-type: none"> <li>• (1) – <b>720 mm</b> cable, add-in card x8 SlimSAS connector to Midplane card 2 x4 SlimSAS connectors</li> <li>• (1) – <b>820 mm</b> cable, add-in card x8 SlimSAS connector to Midplane card 2 x4 SlimSAS connectors</li> </ul>
	<p><b>iPC</b> CYPBLSL2216NX2  <b>MM#</b> 99AP97  <b>UPC</b> 00735858499712  <b>EAN</b> 5032037234702  <b>MOQ</b> 1</p>	<p>Used in M50CYP2UR x16 system to connect SB CPU0 SlimSAS connectors to HSBP (on the right) for front NVMe drive support.</p> <p><b>Kit Includes:</b></p> <ul style="list-style-type: none"> <li>• (1) – <b>370/390 mm</b> cable, SB CPU0 x4 SlimSAS C/D to HSBP x8 SlimSAS connector that connects to SSD 10/11, VT → VT</li> <li>• (1) – <b>412/420 mm</b> cable, SB CPU0 x4 SlimSAS A/B to HSBP x8 SlimSAS connector that connects to SSD 8/9, VT → VT</li> </ul>

Image	Details	Description
	<p> <b>iPC</b> CBLSLHDKIT  <b>MM#</b> 99C3FZ  <b>UPC</b> 00735858527774  <b>EAN</b> 5032037259767  <b>MOQ</b> 1                 </p>	<p>Used in 1U/2U systems to connect tri-mode RAID add-in card to HSBP for front SAS/SATA up to 16 drive support.</p> <p><b>Kit Includes:</b></p> <ul style="list-style-type: none"> <li>• (1) – <b>860 mm</b> cable, RAID x8 SlimSAS connector to HSBP 2 x4 Mini-SAS HD connectors</li> <li>• (1) – <b>660 mm</b> cable, RAID x8 SlimSAS connector to HSBP 2 x4 Mini-SAS HD connectors</li> </ul>
	<p> <b>iPC</b> AXXCBLHDHD1150  <b>MM#</b> 99AVKV  <b>UPC</b> 00735858507196  <b>EAN</b> 5032037241335  <b>MOQ</b> 1                 </p>	<p>Used in 1U systems to connect Mini-SAS HD SAS/RAID Riser 1 controller to Mini-SAS HD port on first HSBP for drives 0–3.</p> <p><b>Kit Includes:</b></p> <ul style="list-style-type: none"> <li>• (1) – <b>1150 mm</b> cable, connects SAS add-in card Mini-SAS HD connector to HSBP Mini-SAS HD connector (VT to VT)</li> </ul>

### 4.2.3 Cable Recommendations

Each table in the following sections identifies the cable connections and recommended cable lengths for each supported storage controller option in the specified system. Each recommended cable length for a given connector pair provides enough cable to attach the two devices and provides the least amount of excess cable, providing the cleanest cable routing.

Refer to the following diagrams when **Right** or **Left** cable routing is specified for a given cable configuration. All cable recommendations are for a system configured for two processors.

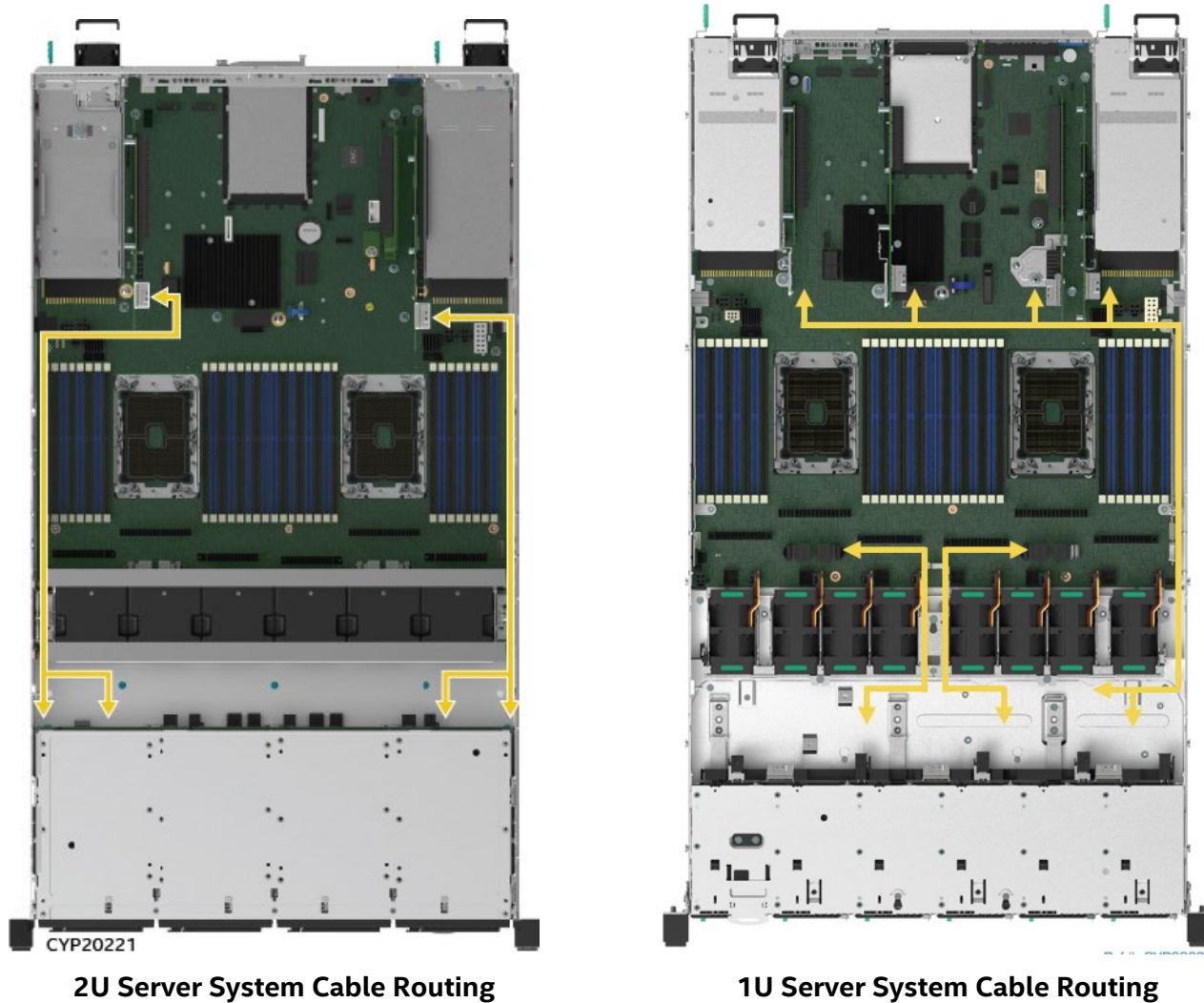


Figure 22. Server System Cable Routing

### 4.3 1U 4 x 2.5" – M50CYP1UR204 SAS /SATA / NVMe\* Data Cable Guide

M50CYP1UR204xxx



Figure 22. 4 x 2.5" Front Drive Bay Configuration – M50CYP1UR204

**Note:** A splitter cable is a cable that has two or more connectors on one end.

Table 19. Data Cable Guide for Intel® Server System M50CYP1UR204

Drive Support	SATA Server Board (SB) Mini-SAS HD SATA → Backplane (BP) Mini-SAS HD	SAS/SATA 12 Gb SAS ROC Module Mini- SAS HD → Backplane (BP) Mini-SAS HD	SAS/SATA 12 Gb SAS RAID PCIe* Add-in Card Mini-SAS HD → Backplane (BP) Mini-SAS HD	NVMe* NVMe* Server Board (SB) x4 PCIe* SlimSAS → Backplane (BP) x8 PCIe SlimSAS	NVMe* Riser 3 PCIe NVMe Riser Card x8 SlimSAS → Backplane (BP) x8 SlimSAS
<p>4 x 2.5"</p> <ul style="list-style-type: none"> <li>6 Gb SATA all drives</li> <li>12 Gb SAS all drives</li> <li>PCIe NVMe all drives</li> </ul>	<p>SB SATA (0-3) → BP SATA Port 0-3</p> <ul style="list-style-type: none"> <li>Included in cable kit: <b>CYPCBLHDHDX1</b></li> <li>840 mm cable, RA → VT</li> <li>Routed along the right side of chassis.</li> </ul>	<p><b>Part 1:</b> Connecting server board → SAS Interposer card (iPC <b>CYPSASMODINT</b>).</p> <hr/> <p><b>Note:</b> SAS Interposer card is needed to enable SAS ROC module. Cable kit iPC <b>CYPCBLSLINTKIT</b> is used to connect server board to SAS Interposer card. Both SlimSAS connectors on the SAS Interposer card must be connected to the same CPU. The remaining SlimSAS connector connected to the same CPU cannot be used for NVMe front drive bay connectivity.</p>	<p>Add-in card connected to Riser 1 card or PCIe Interposer card or Riser 2 card: -</p> <p>Add-in card SATA (0-3) → BP SATA Port 0-3</p> <ul style="list-style-type: none"> <li>Included in cable kit: iPC <b>CYPCBLHDHDX1</b></li> <li>930 mm cable, VT → RA.</li> <li>Routed along the right side of chassis.</li> </ul>	<p>All cables are routed through the middle of fan assembly</p> <p>SB CPU0 x4 SlimSAS A and B → BP x8 SlimSAS PCIe SSD 0-1</p> <ul style="list-style-type: none"> <li>412/420 mm splitter cable, RRA → VT.</li> <li>Routed through the middle of the fan assembly</li> </ul> <p>SB CPU1 x4 SlimSAS A and B → BP x8 SlimSAS PCIe SSD 2-3</p> <ul style="list-style-type: none"> <li>412/420 mm splitter cable, RRA → VT</li> <li>Routed through the middle of the fan assembly</li> </ul> <p>Cable kit: iPC <b>CYPCBLSL104KIT</b> includes</p> <p>(1) 412/420 mm splitter cable</p>	<p><b>NOT SUPPORTED</b></p>

Drive Support	<b>SATA</b> Server Board (SB) Mini-SAS HD SATA → Backplane (BP) Mini-SAS HD	<b>SAS/SATA</b> 12 Gb SAS ROC Module Mini- SAS HD → Backplane (BP) Mini-SAS HD	<b>SAS/SATA</b> 12 Gb SAS RAID PCIe* Add-in Card Mini-SAS HD → Backplane (BP) Mini-SAS HD	<b>NVMe*</b> NVMe* Server Board (SB) x4 PCIe* SlimSAS → Backplane (BP) x8 PCIe SlimSAS	<b>NVMe*</b> Riser 3 PCIe NVMe Riser Card x8 SlimSAS → Backplane (BP) x8 SlimSAS
		<p>SB CPU0 x4 SlimSAS A or                      CPU1 x4 SlimSAS D → SAS                      Interposer card x4 SlimSAS A</p> <ul style="list-style-type: none"> <li>• 250 mm cable, VT → RA</li> <li>• Routed through middle of fan assembly.</li> </ul> <p>SB CPU0 x4 SlimSAS A or                      CPU1 x4 SlimSAS D → SAS                      Interposer card x4 SlimSAS B</p> <ul style="list-style-type: none"> <li>• 250 mm cable, RRA → RA</li> <li>• Routed through middle of fan assembly.</li> </ul> <p>The above required cables are in cable kit: iPC  <b>CYPCBLSLINTKIT</b></p> <hr/> <p><b>Part 2:</b> Connecting SAS Interposer card → BP.</p> <hr/> <p><b>Note:</b> The ROC module connects to the mezzanine connector on the SAS Interposer card.</p> <p><b>ROC Mini-SAS HD PORT 0 → BP SATA 0–3</b></p> <ul style="list-style-type: none"> <li>• Included in cable kit: iPC  <b>CYPCBLMEZKIT</b></li> <li>• 385 mm cable, LS → VT</li> </ul>			

## 4.4 1U 12 x 2.5" – M50CYP1UR212 SAS / SATA / NVMe\* Data Cable Guide

M50CYP1UR212xxx



Figure 23. 12 x 2.5" Front Drive Bay Configuration – M50CYP1UR212

**Note:** A splitter cable is a cable that has two or more connectors on one end.

Table 20. Data Cable Guide for Intel® Server System M50CYP1UR212

Drive Support	SATA Server Board (SB) Mini-SAS HD SATA → Backplane (BP) Mini-SAS HD	SAS/SATA SAS Mezzanine 12 Gb SAS ROC Module Mini-SAS HD → Backplane (BP) Mini-SAS HD	SAS/SATA 12 Gb SAS RAID PCIe* Add-in Card Mini-SAS HD → Backplane (BP) Mini-SAS HD	NVMe* Server Board (SB) PCIe* NVMe* x4 SlimSAS → Backplane (BP) x8 SlimSAS	NVMe* Riser 3 PCIe NVMe Riser Card x8 SlimSAS → Backplane (BP) x8 SlimSAS
<p>12 x 2.5"</p> <ul style="list-style-type: none"> <li>6 Gb SATA all drives</li> <li>12 Gb SAS all drives</li> <li>PCIe NVMe all drives</li> </ul>	<p>SB SATA (0-3) → BP SATA Port 4-7</p> <ul style="list-style-type: none"> <li>930 mm cable, RA → VT</li> <li>Routed along the right side of chassis.</li> </ul> <p>SB SATA (4-7) → BP SATA Port 8-11</p> <ul style="list-style-type: none"> <li>840 mm cable, RA → VT</li> <li>Routed along the right side of chassis.</li> </ul> <p>Required cables above are in cable kit: <b>CYPCBLHDHDXXX1</b></p>	<p><b>Part 1:</b> Connecting server board → SAS Interposer card (iPC <b>CYPSASMODINT</b>).</p> <p><b>Note:</b> SAS Interposer card is needed to enable SAS ROC module. Cable kit iPC <b>CYPCBLSLINTKIT</b> is used to connect server board to SAS Interposer card. Both SlimSAS connectors on the SAS Interposer card must be connected to the same CPU. The remaining SlimSAS connector connected to the same CPU cannot be used for NVMe front drive bay connectivity.</p>	<p><b>Note:</b> Cables are routed along the right side of chassis.</p> <p><b>Add-in card on Riser 2 card:-</b></p> <p><b>Add-in card PORT 0 → BP SATA Port 0-3</b></p> <ul style="list-style-type: none"> <li>930 mm cable, VT → RA.</li> </ul> <p><b>Add-in card PORT 1 → BP SATA Port 4-7</b></p> <ul style="list-style-type: none"> <li>840 mm cable, VT → RA.</li> </ul> <p><b>Add-in card PORT 2 → BP SATA Port 8-11</b></p> <ul style="list-style-type: none"> <li>640 mm cable, VT → VT.</li> </ul>	<p>SB CPU0 SlimSAS A and B → BP SlimSAS SSD0-1</p> <ul style="list-style-type: none"> <li>412/420 mm splitter cable, RRA → VT</li> <li>Routed through middle of fan assembly</li> </ul> <p>SB CPU0 SlimSAS C and D → BP SlimSAS SSD2-3</p> <ul style="list-style-type: none"> <li>350/342 mm splitter cable, RRA → VT</li> <li>Routed along left of chassis.</li> </ul> <p>SB CPU1 SlimSAS A and B → BP SlimSAS SSD8-9</p> <ul style="list-style-type: none"> <li>312/320 mm cable, RRA → VT</li> <li>Routed along right of chassis.</li> </ul>	<p>Riser 3 NVMe riser card SlimSAS PCIe_SSD_0-1 connector → BP SlimSAS SSD4-5, or SSD6-7, or SSD8-9, or SSD10-11</p> <ul style="list-style-type: none"> <li>660 mm cable, VT → VT</li> <li>Routed along right of chassis.</li> </ul> <p>Riser 3 NVMe riser card SlimSAS PCIe_SSD_2-3 connector → BP SlimSAS SSD4-5, or SSD6-7, or SSD8-9, or SSD10-11</p> <ul style="list-style-type: none"> <li>660 mm cable, VT → VT</li> <li>Routed along right of chassis.</li> </ul>

Drive Support	SATA Server Board (SB) Mini-SAS HD SATA → Backplane (BP) Mini-SAS HD	SAS/SATA SAS Mezzanine 12 Gb SAS ROC Module Mini-SAS HD → Backplane (BP) Mini-SAS HD	SAS/SATA 12 Gb SAS RAID PCIe* Add-in Card Mini-SAS HD → Backplane (BP) Mini-SAS HD	NVMe* Server Board (SB) PCIe* NVMe* x4 SlimSAS → Backplane (BP) x8 SlimSAS	NVMe* Riser 3 PCIe NVMe Riser Card x8 SlimSAS → Backplane (BP) x8 SlimSAS
		<p>SB CPU0 x4 SlimSAS A or CPU1 x4 SlimSAS D → SAS Interposer card x4 SlimSAS A</p> <ul style="list-style-type: none"> <li>• 250 mm cable, VT → RA</li> <li>• Routed through middle of fan assembly.</li> </ul> <p>SB CPU0 x4 SlimSAS A or CPU1 x4 SlimSAS D → SAS Interposer card x4 SlimSAS A</p> <ul style="list-style-type: none"> <li>• 250 mm cable, RRA → RA</li> <li>• Routed through middle of fan assembly.</li> </ul> <p>Required cables above are in cable kit: iPC <b>CYPCBLSLINTKIT</b></p> <hr/> <p><b>Part 2: Connecting SAS Interposer card → BP.</b></p> <hr/> <p>ROC Mini-SAS HD PORT 0 → BP SATA 0–3</p> <ul style="list-style-type: none"> <li>• 385 mm cable, Left side → VT</li> </ul> <p>ROC Mini-SAS HD PORT 1 → BP SATA 4–7</p> <ul style="list-style-type: none"> <li>• 140 mm cable, right side → RA</li> </ul> <p>ROC Mini-SAS HD PORT 2 → BP SATA 8–11</p> <ul style="list-style-type: none"> <li>• 140 mm cable, right side → RA</li> </ul> <p>Required cables above are in cable kit: iPC <b>CYPCBLMEZKIT</b></p>	<p>Required cables above are in cable kit: iPC <b>CYPCBLHDHDX1</b></p> <p><b>Add-in card on Riser 1 card or Interposer card:-</b></p> <p><b>Add-in card PORT 0 → BP SATA Port 4–7</b></p> <ul style="list-style-type: none"> <li>• 930 mm cable, VT → RA.</li> </ul> <p><b>Add-in card PORT 1 → BP SATA Port 8–11</b></p> <ul style="list-style-type: none"> <li>• 810 mm cable, VT → RA.</li> </ul> <p>Required cables above are in cable kit: iPC <b>CYPCBLHDHDX1</b></p>	<p><b>SB CPU1 SlimSAS C and D →BP SlimSAS SSD10-11</b></p> <ul style="list-style-type: none"> <li>• 400/392 mm splitter cable, RRA → VT</li> <li>• Routed through middle of fan assembly</li> </ul> <p>Required cables above are in cable kit: iPC <b>CYPCBLSL112KIT</b></p>	<p>Required cables above are in cable kit: iPC <b>CYPCBLSLRKIT</b></p>

## 4.5 2U 2.5" Front Mount Drive Bay Cable Guide

The 2U 2.5" system can support up to 24 front drive bays using three 8 x 2.5" SAS/SATA NVMe drive combo backplanes.

The 2U 2.5" system supports the following system configurations: 8 drives (**M50CYP2UR208**), 16 drives (**M50CYP2UR208 + 8 Drive Accessory Kit**), or 24 drives (**M50CYP2UR208 + two 8 Drive Accessory Kits**).

The front side of the backplane includes eight 68-pin SFF-8639 drive interface (U.2) connectors, each capable of supporting SAS, SATA, or NVMe drives. The connectors are labeled "SSD\_0" through "SSD\_7".

The backside of the backplane includes two multiport Mini-SAS HD connectors labeled "SAS/SATA PORT 0-3" and "SAS/SATA PORT 4-7", and four x8 PCIe SlimSAS connectors, labeled "PCIe SSD 0-1", "PCIe SSD 2-3", "PCIe SSD 4-5", and "PCIe SSD 6-7". Each x8 PCIe SlimSAS connector is routed to two U.2 connectors on the front side. For example, PCIe SSD 0-1 is routed to SSD\_0 and SSD\_1.

### 4.5.1 M50CYP2UR208 SAS / SATA / NVMe\* Data Cable Guide for up to 8 Front Drive Bays

**Note:** Drive numbering in the system illustrations is for general reference only. Actual drive numbering is dependent on SAS/SATA controller configuration and how they are cabled to the backplane.



Figure 24. 2U 8 x 2.5" Front Drive Bay Configuration – M50CYP2UR208

**Note:** A splitter cable is a cable that has two or more connectors on one end.

**Table 21. M50CYP2UR208 Cable Guide for up to 8 Front Drive Bays**

Drive Support	SATA Server Board (SB) Mini-SAS HD SATA → Backplane (BP) Mini-SAS HD	SAS/SATA Mezzanine SAS ROC Module → Backplane (BP)	SAS/SATA 12 Gb SAS RAID PCIe* Add-in Card Mini-SAS HD → Backplane (BP) Mini-SAS HD	NVMe* Server Board (SB) PCIe* NVMe* x4 SlimSAS → Backplane (BP) x8 SlimSAS	NVMe* PCIe* NVMe* Riser Card x8 SlimSAS → Backplane (BP) x8 SlimSAS
<p>8 x 2.5"</p> <ul style="list-style-type: none"> <li>6 Gb SATA all drives</li> <li>12 Gb SAS all drives</li> <li>PCIe NVMe all drives</li> </ul>	<p><b>SB SATA (0-3) → BP SATA Port 0-3</b></p> <ul style="list-style-type: none"> <li>840 mm cable, RA → VT</li> <li>Routed along the left side of chassis.</li> </ul> <p><b>SB SATA (4-7) → BP SATA Port 4-7</b></p> <ul style="list-style-type: none"> <li>930 mm cable, RA → VT</li> <li>Routed along the left side of chassis.</li> </ul> <p>Required cables above are in cable kit: <b>CYPCBLHDHDX1</b></p>	<p><b>Part 1:</b> Connecting server board → SAS Interposer card (iPC <b>CYPSASMODINT</b>).</p> <hr/> <p><b>Note:</b> SAS Interposer card is needed to enable SAS ROC module. Cable kit iPC <b>CYPCBLSLINTKIT</b> is used to connect server board to SAS Interposer card. Both SlimSAS connectors on the SAS Interposer card must be connected to the same CPU. The remaining SlimSAS connector connected to the same CPU cannot be used for NVMe front drive bay connectivity.</p> <p><b>SB CPU0 x4 SlimSAS A or CPU1 x4 SlimSAS D → SAS Interposer card x4 SlimSAS A</b></p> <ul style="list-style-type: none"> <li>250 mm cable, VT → RA</li> <li>Routed underneath fan assembly.</li> </ul> <p><b>SB CPU0 x4 SlimSAS B or CPU1 x4 SlimSAS C → SAS Interposer card x4 SlimSAS B</b></p> <ul style="list-style-type: none"> <li>250 mm cable, RRA → RA</li> <li>Routed underneath fan assembly.</li> </ul> <p>Required cables above are in cable kit: iPC <b>CYPCBLSLINTKIT</b></p>	<p><b>Part 1:</b> Add-in card connected to Riser 1 card OR Riser 2 card OR Riser 3 card:</p> <hr/> <p><b>Add-in card connected to Riser 1 card OR Riser 2 card OR Riser 3 card:</b></p> <p><b>Add-in card connected to Riser 1 card OR Riser 2 card OR Riser 3 card:-</b></p> <p><b>Note:</b> If using Riser 1, route the cables through the left side of the chassis. If using Riser 2 or Riser 3, route the cables through the right side of the chassis.</p> <p><b>Add-in card PORT 0 → BP SATA Port 0-3</b></p> <ul style="list-style-type: none"> <li>930 mm cable, VT → RA.</li> </ul> <p><b>Add-in card PORT 1 → BP SATA Port 4-7</b></p> <ul style="list-style-type: none"> <li>840 mm cable, VT → RA.</li> </ul>	<p>All cables are routed underneath the fan assembly</p> <p><b>SB CPU0 SlimSAS A and B → BP SlimSAS SSD0-1</b></p> <ul style="list-style-type: none"> <li>240/260 mm splitter cable, VT → VT</li> </ul> <p><b>SB CPU0 SlimSAS C and D → BP SlimSAS SSD2-3</b></p> <ul style="list-style-type: none"> <li>330/310 mm splitter cable, VT → VT</li> </ul> <p><b>SB CPU1 SlimSAS C and D → BP SlimSAS SSD6-7</b></p> <ul style="list-style-type: none"> <li>235/215 mm splitter cable, VT → VT</li> </ul> <p><b>SB CPU1 SlimSAS A and B → BP SlimSAS SSD4-5</b></p> <ul style="list-style-type: none"> <li>370/390 mm splitter cable, VT → VT</li> </ul> <p>Required cables above are in cable kit: iPC <b>CYPCBLSL208KIT</b></p>	<p>From Riser 1 NVMe* Riser card:</p> <p><b>SlimSAS PCIe_SSD_0-1 → BP SlimSAS SSD0-1</b></p> <ul style="list-style-type: none"> <li>660 mm cable, VT → VT</li> <li>Routed along left of chassis.</li> </ul> <p><b>SlimSAS PCIe_SSD_2-3 → BP SlimSAS SSD2-3</b></p> <ul style="list-style-type: none"> <li>660 mm cable, VT → VT</li> <li>Routed along left of chassis.</li> </ul> <p>From Riser 3 NVMe* Riser card:</p> <p><b>SlimSAS PCIe_SSD_0-1 → BP SlimSAS SSD4-5</b></p> <ul style="list-style-type: none"> <li>660 mm cable, VT → VT</li> <li>Routed along right of chassis.</li> </ul> <p><b>SlimSAS PCIe_SSD_2-3 → BP SlimSAS SSD6-7</b></p> <ul style="list-style-type: none"> <li>660 mm cable, VT → VT</li> <li>Routed along right of chassis.</li> </ul> <p>Required cables above are in cable kit: iPC</p>

Drive Support	SATA Server Board (SB) Mini-SAS HD SATA → Backplane (BP) Mini-SAS HD	SAS/SATA Mezzanine SAS ROC Module → Backplane (BP)	SAS/SATA 12 Gb SAS RAID PCIe* Add-in Card Mini-SAS HD → Backplane (BP) Mini-SAS HD	NVMe* Server Board (SB) PCIe* NVMe* x4 SlimSAS → Backplane (BP) x8 SlimSAS	NVMe* PCIe* NVMe* Riser Card x8 SlimSAS → Backplane (BP) x8 SlimSAS
		<p><b>Part 2:</b> Connecting SAS Interposer card → BP.</p> <hr/> <p><b>Note:</b> The ROC module connects to the mezzanine connector on the SAS Interposer card.</p> <p><b>ROC Mini-SAS HD PORT 0 → BP SATA 0-3</b></p> <ul style="list-style-type: none"> <li>• 180 mm cable, VT → VT</li> </ul> <p><b>ROC Mini-SAS HD PORT 1 → BP SATA 4-7</b></p> <ul style="list-style-type: none"> <li>• 250 mm cable, VT → VT</li> </ul> <p>Required cables above are in cable kit: iPC <b>CYPCBLHDHDXXX2</b></p>	<p>Required cables above are in cable kit: iPC <b>CYPCBLHDHDXXX1</b></p>		<p><b>CYPCBLSLRTKIT</b> that contains (2) <b>660 mm</b> cable, VT → VT</p>

#### 4.5.2 Intel® Server System M50CYP2UR 16 x 2.5" SAS / SATA / NVMe\* Data Cable Guide

**Notes:**

- For M50CYP2UR 16 x 2.5" configurations, ensure that the ventilation blank is installed in the middle of the chassis as shown in the following figure.
- Drive numbering in the system illustrations is for general reference only. Actual drive numbering is dependent on SAS/SATA controller configuration and how they are cabled to the backplane.



**Figure 25. 2U 16 x 2.5" Front Drive Bay Configuration**

The following accessory kits are needed to convert a M50CYP2UR208 system into a 9–16 front drive bay configuration.

- (1) 8 x 2.5" Hot Swap backplane kit **CYPHSBP2208**
- (1) 2.5" front drive bay module **CYP25HSCARRIER**

---

**Note:** Support for connectivity between 12 Gb SAS RAID PCIe add-in card and SAS Expander card is planned as part of post product launch release.

---

**Table 22. 2U 2.5" SAS/SATA Cable Guide for 9–16 Front Drive Bays**

Drive Support	SATA Server Board (SB) Mini-SAS HD SATA → Backplane (BP) Mini-SAS HD	SAS/SATA Mezzanine SAS ROC Module → Backplane (BP)	SAS/SATA 12 Gb SAS RAID PCIe* Add-in Card Mini-SAS HD → Backplane (BP) Mini-SAS HD	SAS/SATA 4 or 8-port 12Gb SAS RAID PCIe* Add- in Card → 12 Gb SAS Expander → Backplane (BP)
<p>16 x 2.5"</p> <ul style="list-style-type: none"> <li>6 Gb SATA all drives</li> <li>12 Gb SAS all drives</li> </ul>	<p><b>SB SATA (0-3) or SATA (4-7) → BP SATA Port 0–3 or Port 4–7 or Port 8–11</b></p> <ul style="list-style-type: none"> <li>840 mm cable, RA → VT</li> <li>Routed along the left side of chassis.</li> </ul> <p><b>SB SATA (0-3) or SATA (4-7) → BP SATA Port 12–15</b></p> <ul style="list-style-type: none"> <li>930 mm cable, RA → VT</li> <li>Routed along the left side of chassis.</li> </ul> <p>Required cables above are in cable kit: iPC <b>CYPCBLHDHDX1</b></p>	<p><b>Part 1: Connecting server board → SAS Interposer card (iPC <b>CYPSASMODINT</b>).</b></p> <p><b>Note:</b> SAS Interposer card is needed to enable SAS ROC module. Cable kit iPC <b>CYPCBLSLINTKIT</b> is used to connect server board to SAS Interposer card. Both SlimSAS connectors on the SAS Interposer card must be connected to the same CPU. The remaining SlimSAS connector connected to the same CPU cannot be used for NVMe front drive bay connectivity.</p> <p><b>SB CPU0 x4 SlimSAS A or CPU1 x4 SlimSAS D → SAS Interposer card x4 SlimSAS A</b></p> <ul style="list-style-type: none"> <li>250 mm cable, VT → RA</li> <li>Routed underneath fan assembly.</li> </ul> <p><b>SB CPU0 x4 SlimSAS B or CPU1 x4 SlimSAS C → SAS Interposer card x4 SlimSAS B</b></p> <ul style="list-style-type: none"> <li>250 mm cable, RRA → RA</li> <li>Routed underneath fan assembly.</li> </ul> <p>Required cables above are in cable kit: iPC <b>CYPCBLSLINTKIT</b></p> <p><b>Part 2: Connecting SAS Interposer card → BP.</b></p> <p><b>Note:</b> The ROC module connects to the mezzanine connector on the SAS Interposer card.</p> <p><b>ROC Mini-SAS HD PORT 0 → BP SATA 0–3</b></p> <ul style="list-style-type: none"> <li>540 mm cable, VT → VT</li> </ul>	<p><b>Add-in card connected to Riser 1 card or Riser 2 card or Riser 3 card:-</b></p> <p><b>Note:</b> If using Riser 1, route the cables through the left side of the chassis. If using Riser 2 or Riser 3, route the cables through the right side of the chassis.</p> <p><b>Add-in card PORT 0 → BP SATA Port 0–3</b></p> <ul style="list-style-type: none"> <li>930 mm cable, VT → RA.</li> </ul> <p><b>Add-in card PORT 1 → BP SATA Port 4–7</b></p> <ul style="list-style-type: none"> <li>840 mm cable, VT → RA.</li> </ul> <p><b>Add-in card PORT 2 → BP SATA Port 8–11</b></p> <ul style="list-style-type: none"> <li>640 mm cable, VT → VT.</li> </ul> <p>Required cables above are in cable kit: iPC <b>CYPCBLHDHDX1</b></p> <p><b>Add-in card PORT 3 → BP SATA Port 12–15</b></p> <ul style="list-style-type: none"> <li>640 mm cable, VT → VT.</li> </ul> <p><b>Note:</b> Need to order an additional iPC <b>CYPCBLHDHDX1</b> cable kit to support add-in card PORT 3 connectivity</p>	<p><b>Part 1: Connecting Add-in card → SAS Expander card (iPC <b>RES3TV360</b>)</b></p> <p>(See <a href="#">Figure 26</a> for SAS port mapping)</p> <p><b>Add-in card connected to Riser 1 card or Riser 2 card or Riser 3 card:-</b></p> <p><b>Note:</b> If using Riser 1, route the cables through the left side of the chassis. If using Riser 2 or Riser 3, route the cables through the right side of the chassis.</p> <p><b>Add-in card PORT 0 → SAS Expander 0–3 (G)</b></p> <ul style="list-style-type: none"> <li>930 mm cable, VT → RA.</li> </ul> <p><b>Add-in card PORT 1 → SAS Expander 4–7 (H)</b></p> <ul style="list-style-type: none"> <li>840 mm cable, VT → RA.</li> </ul> <p>Required cables above are in cable kit: iPC <b>CYPCBLHDHDX1</b></p> <p><b>Part 2: Connecting SAS Expander card → BP</b></p>

Drive Support	SATA Server Board (SB) Mini-SAS HD SATA → Backplane (BP) Mini-SAS HD	SAS/SATA Mezzanine SAS ROC Module → Backplane (BP)	SAS/SATA 12 Gb SAS RAID PCIe* Add-in Card Mini-SAS HD → Backplane (BP) Mini-SAS HD	SAS/SATA 4 or 8-port 12Gb SAS RAID PCIe* Add- in Card → 12 Gb SAS Expander → Backplane (BP)
		<p>ROC Mini-SAS HD PORT 1 → BP SATA 4–7</p> <ul style="list-style-type: none"> <li>• 540 mm cable, VT → VT</li> </ul> <p>ROC Mini-SAS HD PORT 2 → BP SATA 8–11</p> <ul style="list-style-type: none"> <li>• 250 mm cable, VT → VT</li> </ul> <p>ROC Mini-SAS HD PORT 3 → BP SATA 12–15</p> <ul style="list-style-type: none"> <li>• 180 mm cable, VT → VT</li> </ul> <p>Cable kit iPC <b>CYPCBLHDHDXXX2</b> contains:</p> <ul style="list-style-type: none"> <li>(1) 180 mm cable, VT → VT</li> <li>(1) 250 mm cable, VT → VT</li> </ul> <p>Cable kit iPC <b>CYPCBLHDHDXXX</b> contains:</p> <ul style="list-style-type: none"> <li>(1) 540 mm cable, VT → VT</li> </ul>		<p>Use <b>RES3TV360</b> accessory kit.</p> <p><b>Kit includes:</b></p> <ul style="list-style-type: none"> <li>(1) – SAS expander card</li> <li>(1) – 130 mm power cable</li> <li>(4) – 165 mm cable, Expander card HD to HSBP HD</li> <li>(1) – 300 mm cable, Expander card HD-to HSBP HD</li> <li>(1) – 250 mm cable, Expander card HD to BP HD</li> <li>(3) – rubber pads</li> <li>mounting screws.</li> </ul>

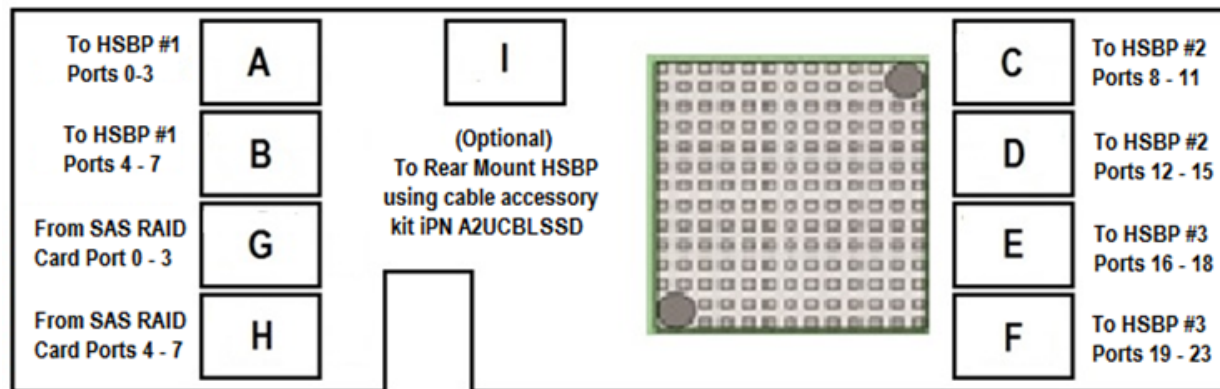


Figure 26. SAS Expander RES3TV360 Port Mapping

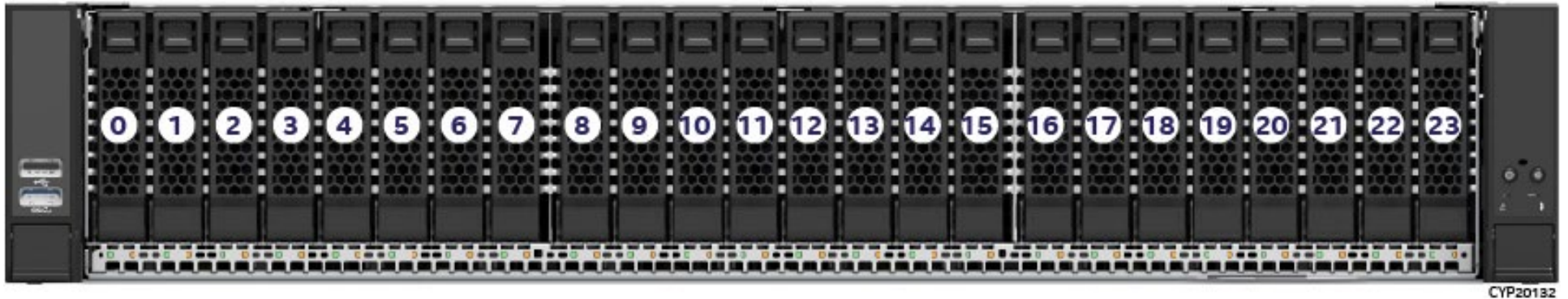
**Note:** A splitter cable is a cable that has two or more connectors on one end.

**Table 23. 2U 2.5" PCIe\* NVMe\* Cable Guide for 9–16 Front Drive Bays**

Drive Support	Server Board (SB) PCIe* NVMe* x4 SlimSAS → Backplane (BP) x8 SlimSAS	PCIe* NVMe* Riser Card x8 SlimSAS → Backplane (BP) x8 SlimSAS
<p><b>16 x 2.5"</b></p> <ul style="list-style-type: none"> <li>• PCIe NVMe all drives</li> </ul>	<p>All cables are routed under the fan assembly</p> <p><b>SB CPU0 SlimSAS C and D → BP SlimSAS SSD6-7</b></p> <ul style="list-style-type: none"> <li>• 275/255 mm splitter cable, VT → VT</li> </ul> <p><b>SB CPU0 SlimSAS A and B → BP SlimSAS SSD4-5</b></p> <ul style="list-style-type: none"> <li>• 305/325 mm splitter cable, VT → VT</li> </ul> <p><b>SB CPU1 SlimSAS C and D → BP SlimSAS SSD14-15</b></p> <ul style="list-style-type: none"> <li>• 360/340 mm splitter cable, VT → VT</li> </ul> <p><b>SB CPU1 SlimSAS A and B → BP SlimSAS SSD12-13</b></p> <ul style="list-style-type: none"> <li>• 260/240 mm splitter cable, VT → VT</li> </ul> <p>Required cables above are in cable kit: iPC <b>CYPCBLSL216KIT</b></p>	<p><b>From Riser 1 NVMe* Riser card:</b></p> <p><b>SlimSAS PCIe_SSD_0-1 → BP SlimSAS SSD0-1</b></p> <ul style="list-style-type: none"> <li>• 660 mm cable, VT → VT</li> <li>• Routed along left of chassis.</li> </ul> <p><b>SlimSAS PCIe_SSD_2-3 → BP SlimSAS SSD2-3</b></p> <ul style="list-style-type: none"> <li>• 660 mm cable, VT → VT</li> <li>• Routed along left of chassis.</li> </ul> <p>Required cables above are in cable kit: <b>CYPCBLSLRKIT</b> that contains (2) 660 mm cable, VT → VT</p> <p><b>From Riser 3 NVMe* Riser card:</b></p> <p><b>SlimSAS PCIe_SSD_0-1 → BP SlimSAS SSD8-9</b></p> <ul style="list-style-type: none"> <li>• 660 mm cable, VT → VT</li> <li>• Routed along right of chassis.</li> </ul> <p><b>SlimSAS PCIe_SSD_2-3 → BP SlimSAS SSD10-11</b></p> <ul style="list-style-type: none"> <li>• 660 mm cable, VT → VT</li> <li>• Routed along right of chassis.</li> </ul> <p>Required cables above are in cable kit: iPC <b>CYPCBLSLRKIT</b> that contains (2) 660 mm cable, VT → VT</p>

### 4.5.3 Intel® Server System M50CYP2UR 24 x 2.5" SAS / SATA / NVMe\* Data Cable Guide

**Note:** Drive numbering in the system illustrations is for general reference only. Actual drive numbering is dependent on SAS/SATA controller configuration and how they are cabled to the backplane.

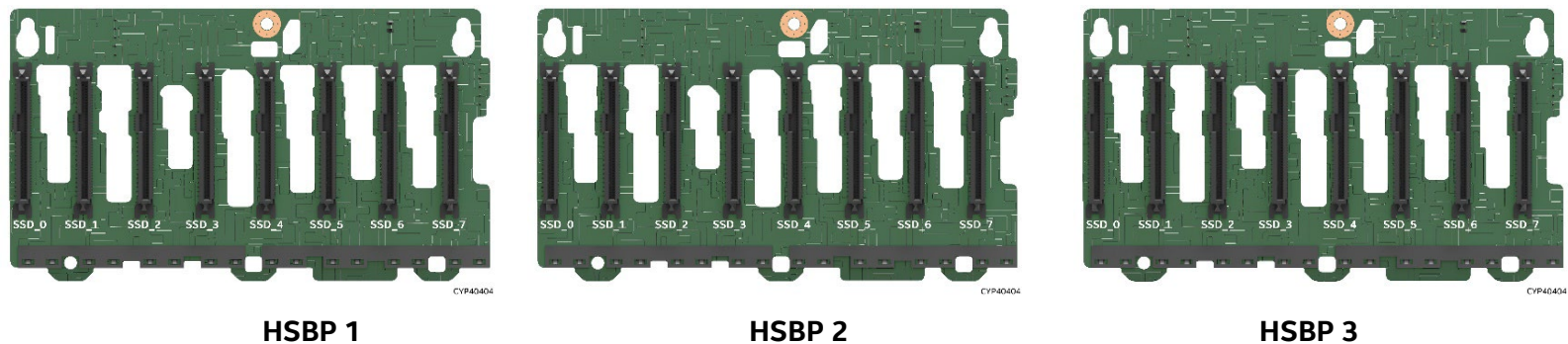


**Figure 27. 2U 24 x 2.5" M50CYP2UR208 Front Drive Bay Configuration**

The following accessory kits are needed to convert a M50CYP2UR208 system into a 17– 24 front drive bay configuration.

- (2) 8 x 2.5" Hot Swap backplane kit CYPHSBP2208
- (2) 2.5" front drive bay module CYP25HSCARRIER

**Note:** Support for connectivity between 12 Gb SAS RAID PCIe add-in card and SAS Expander card is planned as part of post product launch releases.



**Figure 28. 2U 2.5" x 24 System HSBP Enumeration**

**Table 24. 2U 2.5" SAS / SATA Cable Guide for 17–24 Front Drive Bays**

Drive Support	SAS/SATA 12 Gb SAS RAID PCIe* Add-in Card Mini-SAS HD → Backplane (BP) Mini-SAS HD	SAS/SATA 4 or 8-port Mezzanine 12Gb SAS ROC Module → SAS Expander Card → Backplane (BP)	SAS/SATA 4 or 8-port 12Gb SAS RAID PCIe* Add-in Card → 12 Gb SAS Expander → Backplane (BP)
<p>24 x 2.5"</p> <ul style="list-style-type: none"> <li>6 Gb SATA all drives</li> <li>12 Gb SAS all drives</li> </ul>	<p><b>Part 1:</b> Connecting Add-in card → HSBP 2 &amp; 3 SAS/SATA port.</p> <hr/> <p><b>Add-in card connected to Riser 1 card or Riser 2 card or Riser 3 card:-</b></p> <p><b>Note:</b> If using Riser 1, route the cables through the left side of the chassis. If using Riser 2 or Riser 3, route the cables through the right side of the chassis.</p> <p><b>Add-in card PORT 0 → BP SATA Port 16–19</b></p> <ul style="list-style-type: none"> <li>930 mm cable, RA → VT.</li> </ul> <p><b>Add-in card PORT 1 → BP SATA Port 20–23</b></p> <ul style="list-style-type: none"> <li>840 mm cable, RA → VT.</li> </ul> <p>Required cables above are in cable kit: iPC <b>CYPCBLHDHDX1</b></p> <hr/> <p><b>Part 2:</b> Connecting server board → HSBP 1 SAS/SATA port.</p> <hr/> <p><b>SB SATA (0-3) → BP SATA Port 0–3</b></p> <ul style="list-style-type: none"> <li>Included in cable kit: <b>CYPCBLHDHDX1</b></li> <li>930 mm cable, RA → VT.</li> <li>840 mm cable, RA → VT</li> <li>Routed along the left side of chassis.</li> </ul>	<p><b>Part 1:</b> Connecting server board → SAS Interposer card (iPC <b>CYPSASMODINT</b>).</p> <hr/> <p><b>Note:</b> SAS Interposer card is needed to enable SAS ROC module. Cable kit <b>CYPCBLSLINTKIT</b> is used to connect server board to SAS Interposer card. Both SlimSAS connectors on the SAS Interposer card must be connected to the same CPU. The remaining SlimSAS connector connected to the same CPU cannot be used for NVMe front drive bay connectivity.</p> <p><b>SB CPU0 x4 SlimSAS A or CPU1 x4 SlimSAS D → AS Interposer card x4 SlimSAS A</b></p> <ul style="list-style-type: none"> <li>250 mm cable, VT → RA</li> <li>Routed underneath fan assembly.</li> </ul> <p><b>SB CPU0 x4 SlimSAS B or CPU1 x4 SlimSAS C → SAS Interposer card x4 SlimSAS B</b></p> <ul style="list-style-type: none"> <li>250 mm cable, RRA → RA</li> <li>Routed underneath fan assembly.</li> </ul> <p>The above required cables are in cable kit: iPC <b>CYPCBLSLINTKIT</b></p> <hr/> <p><b>Part 2:</b> Connecting ROC Module to SAS Expander card.</p> <hr/> <p><b>Add-in card PORT 0 → SAS Expander 0–3 (G)</b></p> <ul style="list-style-type: none"> <li>540 mm cable, VT → VT.</li> </ul>	<p><b>PART 1:</b> Connecting Add-in card → SAS Expander card (iPC <b>RES3TV360</b>)</p> <hr/> <p>(See <a href="#">Figure 26</a> for SAS port mapping) <b>Add-in card connected to Riser 1 card or Riser 2 card or Riser 3 card:-</b></p> <p><b>Note:</b> If using Riser 1, route the cables through the left side of the chassis. If using Riser 2 or Riser 3, route the cables through the right side of the chassis.</p> <p><b>Add-in card PORT 0 → SAS Expander 0–3 (G)</b></p> <ul style="list-style-type: none"> <li>930 mm cable, VT → RA.</li> </ul> <p><b>Add-in card PORT 1 → SAS Expander 4–7 (H)</b></p> <ul style="list-style-type: none"> <li>840 mm cable, VT → RA.</li> </ul> <p>Required cables above are in cable kit: iPC <b>CYPCBLHDHDX1</b></p> <hr/> <p><b>PART 2:</b> Connecting SAS Expander card → BP</p> <hr/> <p>(See <a href="#">Figure 28</a>)</p> <p><b>Included with SAS Expander Module:</b> iPC <b>RES3TV360</b> kit (4) 165 mm cable, Mini-SAS HD from SAS Expander card → Mini-SAS HD on HSBP 1 and 2.</p>

Drive Support	SAS/SATA 12 Gb SAS RAID PCIe* Add-in Card Mini-SAS HD → Backplane (BP) Mini-SAS HD	SAS/SATA 4 or 8-port Mezzanine 12Gb SAS ROC Module → SAS Expander Card → Backplane (BP)	SAS/SATA 4 or 8-port 12Gb SAS RAID PCIe* Add-in Card → 12 Gb SAS Expander → Backplane (BP)
		<p><b>Add-in card PORT 0 → SAS Expander 0–3 (H)</b></p> <ul style="list-style-type: none"> <li>• <b>540 mm</b> cable, VT → VT.</li> </ul> <p>Cable kit iPC <b>CYPCBLHDHDXXX</b> includes: (1) <b>540 mm</b> cable, VT → VT</p> <hr/> <p><b>Part 3: Connecting Expander card to BP.</b></p> <p><b>Included with SAS Expander Module: RES3TV360 kit</b></p> <p>(4) <b>165 mm</b> cable, Mini-SAS HD from SAS Expander card → Mini-SAS HD on HSBP 1 and 2.</p> <p>(1) <b>250 mm</b> cable Mini-SAS HD from SAS Expander card → Mini-SAS HD on HSBP 3.</p> <p>(1) <b>300 mm</b> cable, Mini-SAS HD from SAS Expander card → Mini-SAS HD on HSBP 1 and 2. x</p> <p>(1) <b>130 mm</b> cable, Power cable (2x2 pin to two 2x2 pin), server board (Left) → SAS ROC module.</p>	<p>(1) <b>250 mm</b> cable, Mini-SAS HD from SAS Expander card → Mini-SAS HD on HSBP 3.</p> <p>(1) <b>300 mm</b> cable, Mini-SAS HD from SAS Expander card → Mini-SAS HD on HSBP 1 and 1.</p> <p>(1) <b>130 mm</b> cable, Power cable (2x2 pin to two 2x2 pin), server board-Left → SAS ROC module.</p>

**Table 25. 2U 2.5" PCIe\* NVMe\* Cable Guide for 17–24 Front Drive Bays**

Drive Support	Left Midplane Card x8 SlimSAS → Backplane (BP) x8 SlimSAS	Right Midplane x8 SlimSAS → Backplane (BP) x8 SlimSAS
<p>24 x 2.5"</p> <ul style="list-style-type: none"> <li>• PCIe NVMe all drives</li> </ul>	<p><b>Part 1: Connecting SB → Midplane Card</b></p> <p><b>Note:</b> All cables below are routed under fan assembly.</p> <p><b>SB CPU0 SlimSAS A → Midplane SlimSAS PCIe* Port A</b></p> <ul style="list-style-type: none"> <li>• 160 mm cable, VT → VT</li> </ul> <p><b>SB CPU0 SlimSAS B → Midplane SlimSAS PCIe* Port B</b></p> <ul style="list-style-type: none"> <li>• 160 mm cable, VT → VT</li> </ul> <p><b>SB CPU0 SlimSAS C → Midplane SlimSAS PCIe* Port C</b></p> <ul style="list-style-type: none"> <li>• 160 mm cable, VT → VT</li> </ul> <p><b>SB CPU0 SlimSAS D → Midplane SlimSAS PCIe* Port D</b></p> <ul style="list-style-type: none"> <li>• 160 mm cable, VT → VT</li> </ul> <p><b>Included in cable kit: iPC CYPCBLSLMIDPIN</b> (4) 160 mm cable SB SlimSAS (x4) → Midplane card SlimSAS (x4)</p>	<p><b>Part 1: Connecting server board (SB) → Midplane card:</b></p> <p><b>Note:</b> All cables below are routed under fan assembly.</p> <p><b>SB CPU1 SlimSAS A → Midplane SlimSAS PCIe* Port A</b></p> <ul style="list-style-type: none"> <li>• 160 mm cable, VT → VT</li> </ul> <p><b>SB CPU1 SlimSAS B → Midplane SlimSAS PCIe* Port B</b></p> <ul style="list-style-type: none"> <li>• 160 mm cable, VT → VT</li> </ul> <p><b>SB CPU1 SlimSAS C → Midplane SlimSAS PCIe* Port C</b></p> <ul style="list-style-type: none"> <li>• 160 mm cable, VT → VT</li> </ul> <p><b>SB CPU1 SlimSAS D → Midplane SlimSAS PCIe* Port D</b></p> <ul style="list-style-type: none"> <li>• 160 mm cable, VT → VT</li> </ul> <p><b>Included in cable kit: iPC CYPCBLSLMIDPIN</b> (4) 160 mm cable SB SlimSAS (x4) → Midplane card SlimSAS (x4)</p>
	<p><b>Part 2: Connecting Midplane Card → Backplanes</b></p> <ul style="list-style-type: none"> <li>• SSD0-SSD1 x8 SlimSAS connector on Midplane → HSBP 0 SSD0 and SSD1</li> <li>• SSD2-SSD3 x8 SlimSAS connector on Midplane → HSBP 0 SSD2 and SSD3</li> <li>• SSD4-SSD5 x8 SlimSAS connector on Midplane → HSBP 0 SSD4 and SSD5</li> <li>• SSD6-SSD7 x8 SlimSAS connector on Midplane → HSBP 0 SSD6 and SSD7</li> <li>• SSD8-SSD9 x8 SlimSAS connector on Midplane → HSBP 1 SSD0 and SSD1</li> <li>• SSD10-SSD11 x8 SlimSAS connector on Midplane → HSBP 1 SSD2 and SSD3</li> </ul> <p><b>Included in cable kit: iPC CYPCBLSLMIDPOUT</b> (1) 110 mm cable Midplane card SlimSAS (x8) → HSBP SlimSAS (x8).</p>	<p><b>Part 2: Connecting Midplane card → Backplanes</b></p> <ul style="list-style-type: none"> <li>• SSD0-SSD1 x8 SlimSAS connector on Midplane → HSBP 1 SSD4 and SSD5</li> <li>• SSD2-SSD3 x8 SlimSAS connector on Midplane → HSBP 1 SSD6 and SSD7</li> <li>• SSD4-SSD5 x8 SlimSAS connector on Midplane → HSBP 2 SSD0 and SSD1</li> <li>• SSD6-SSD7 x8 SlimSAS connector on Midplane → HSBP 2 SSD2 and SSD3</li> <li>• SSD8-SSD9 x8 SlimSAS connector on Midplane → HSBP 2 SSD4 and SSD5</li> <li>• SSD10-SSD11 x8 SlimSAS connector on Midplane → HSBP 2 SSD6 and SSD7</li> </ul> <p><b>Included in cable kit: iPC CYPCBLSLMIDPOUT</b> (1) 110 mm cable Midplane card SlimSAS (x8) → HSBP SlimSAS (x8).</p>

## 4.6 2U 12 x 3.5" – M50CYP2UR312 SAS / SATA / NVMe\* Data Cable Guide

M50CYP2UR312xxx



CYP20161

Figure 29. 2U 12 x 3.5" M50CYP2UR312 Front Drive Bay Configuration

Table 26. 2U 12 x 3.5" M50CYP2UR312 SAS / SATA / NVMe\* Cable Guide

Drive Support	SATA Server Board (SB) Mini-SAS HD SATA → Backplane (BP) Mini-SAS HD	SAS/SATA SAS Mezzanine SAS ROC Module → Backplane (BP)	SAS/SATA 12 Gb SAS RAID PCIe* Add-in Card Mini-SAS HD → Backplane (BP) Mini-SAS HD	NVMe* Server Board (SB) PCIe* NVMe* x4 SlimSAS → Backplane (BP) x4 SlimSAS	NVMe* PCIe* NVMe* Riser Card x8 SlimSAS → Backplane (BP) x8 SlimSAS
<p>12 x 3.5"</p> <ul style="list-style-type: none"> <li>6 Gb SATA all drives</li> <li>12 Gb SAS all drives</li> <li>PCIe NVMe on four drive bays</li> </ul>	<p>SB SATA (0-3) → BP SATA Port 0–3 or Port 4–7</p> <ul style="list-style-type: none"> <li>840 mm cable, RA → VT</li> <li>Routed along the left side of chassis.</li> </ul> <p>SB SATA (4-7) → BP SATA Port 4–7 or Port 8–11</p> <ul style="list-style-type: none"> <li>930 mm cable, RA → VT</li> <li>Routed along the left side of chassis.</li> </ul>	<p><b>NOT SUPPORTED</b></p>	<p>Add-in card connected to Riser 1 card OR Riser 2 card OR Riser 3 card:-</p> <p><b>Note:</b> If using Riser 1, route the cables through the left side of the chassis. If using Riser 2 or Riser 3, route the cables through the right side of the chassis.</p> <p>Add-in card SATA PORT 0 → BP SATA Port 0–3</p> <ul style="list-style-type: none"> <li>930 mm cable, VT → RA.</li> </ul>	<p>Route the following cables under the fan assembly.</p> <p>SB CPU0 SlimSAS A→BP SlimSAS PCIe_SSD_4</p> <ul style="list-style-type: none"> <li>175 mm cable, VT → VT</li> </ul> <p>SB CPU0 SlimSAS B→BP SlimSAS PCIe_SSD_5</p> <ul style="list-style-type: none"> <li>200 mm cable, VT → VT</li> </ul>	<p><b>NOT SUPPORTED</b></p>

Drive Support	SATA Server Board (SB) Mini-SAS HD SATA → Backplane (BP) Mini-SAS HD	SAS/SATA SAS Mezzanine SAS ROC Module → Backplane (BP)	SAS/SATA 12 Gb SAS RAID PCIe* Add-in Card Mini-SAS HD → Backplane (BP) Mini-SAS HD	NVMe* Server Board (SB) PCIe* NVMe* x4 SlimSAS → Backplane (BP) x4 SlimSAS	NVMe* PCIe* NVMe* Riser Card x8 SlimSAS → Backplane (BP) x8 SlimSAS
	Required cables above are in cable kit: iPC <b>CYPCBLHDHDX1</b>		Add-in card SATA PORT 1 → BP SATA Port 4–7 <ul style="list-style-type: none"> <li>• 840 mm cable, VT → RA.</li> </ul> Add-in card SATA PORT 2 → BP SATA Port 8–11 <ul style="list-style-type: none"> <li>• 640 mm cable, VT → VT.</li> </ul> Required cables above are in cable kit: iPC <b>CYPCBLHDHDX1</b>	SB CPU1 SlimSAS A→BP SlimSAS PCIe_SSD_6 <ul style="list-style-type: none"> <li>• 205 mm cable, VT → VT</li> </ul> SB CPU1 SlimSAS B→BP SlimSAS PCIe_SSD_7 <ul style="list-style-type: none"> <li>• 180 mm cable, VT → VT</li> </ul> Required cables above are in cable kit: iPC <b>CYPCBLSL204KIT</b>	

## 5. 1U / 2U System Optional Accessories

### 5.1 1U / 2U PCIe\* Riser Card Accessory / Spare FRU Options

#### 5.1.1 1U Riser Card Options

Table 27. 1U Riser Card Option

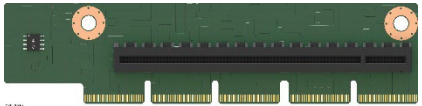
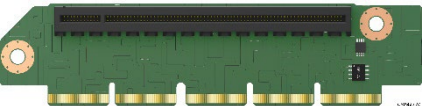
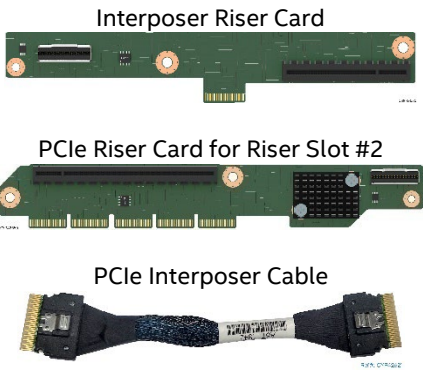

Image	Details	Description
	<p><b>1U 1-Slot PCIe* Riser Card for Riser Slot #1</b></p> <p><b>iPC</b> CYP1URISER1STD  <b>MM#</b> 99A3MX  <b>UPC</b> 00735858471749  <b>EAN</b> 5032037210188  <b>MOQ</b> 1</p> <p><b>Product type</b> 1U building  block/spare FRU  1U accessory kit</p>	<p>Riser card option for Riser Slot #1 only.</p> <p>The one-slot PCIe riser card option supports:</p> <ul style="list-style-type: none"> <li>Slot 1 – One low profile, half-length, single-width add-in card (x16 electrical, x16 mechanical)</li> </ul> <p><b>Kit includes:</b>  (1) Riser card PCBA</p>
	<p><b>1U 1-Slot PCIe* Riser Card for Riser Slot #2</b></p> <p><b>iPC</b> CYP1URISER2STD  <b>MM#</b> 99A3P9  <b>UPC</b> 00735858471756  <b>EAN</b> 5032037210195  <b>MOQ</b> 1</p> <p><b>Product type</b> 1U building  block/spare FRU  1U accessory kit</p>	<p>Riser card option for Riser Slot #2 only.</p> <p>The one-slot PCIe riser card option supports:</p> <ul style="list-style-type: none"> <li>Slot 1 – One low profile, half-length, single-width add-in card (x16 electrical, x16 mechanical)</li> </ul> <p><b>Kit includes:</b>  (1) – Riser card PCBA</p>

Image	Details	Description
 <p>Interposer Riser Card</p> <p>PCIe Riser Card for Riser Slot #2</p> <p>PCIe Interposer Cable</p>	<p><b>1U PCIe* Interposer Kit</b></p> <p><b>iPC</b> CYP1URISER2KIT  <b>MM#</b> 99A3PF  <b>UPC</b> 00735858471770  <b>EAN</b> 5032037210218  <b>MOQ</b> 1</p> <p><b>Product type</b> 1U building block/spare FRU  1U accessory kit</p>	<p>The two-slot PCIe Interposer riser card option supports:</p> <ul style="list-style-type: none"> <li>Slot 1 (right side) — One low profile / half length, single-width add-in card. (x8 electrical, x8 mechanical)</li> <li>PCIe_SSD_0-1 (left side) – (x8 electrical, x8 mechanical)</li> </ul> <p>The two-slot PCIe riser card option for Riser Slot #2 supports:</p> <ul style="list-style-type: none"> <li>Slot 1 (left side) — One low profile / half-length, single-width add-in card. (x16 electrical, x16 mechanical)</li> <li>PCIe_SSD_0-1 (right side) – (x8 electrical, x8 mechanical)</li> </ul> <p><b>Kit includes:</b>  (1) – Interposer riser card PCBA  (1) – PCIe riser card PCBA  (1) – PCIe Interposer cable</p>
	<p><b>1U/2U PCIe* NVMe* Riser Card for Riser Slot #3</b></p> <p><b>iPC</b> CYPRISER3RTM  <b>MM#</b> 99A3PA  <b>UPC</b> 00735858471763  <b>EAN</b> 5032037210201  <b>MOQ</b> 1</p> <p><b>Product type</b> 1U/2U building block/spare FRU  1U/2U accessory kit</p>	<p>Riser card option for Riser Slot #3 only.</p> <p>The Two-Slot PCIe NVMe riser card supports two x8 PCIe SlimSAS connectors labeled “PCIe_SSD_0-1” and “PCIe_SSD_2-3”. Each connector supports up to two NVMe SSDs in the front drive bay through a backplane.</p> <p>The two slot PCIe NVMe riser card option supports:</p> <ul style="list-style-type: none"> <li>PCIe_SSD_0-1 Slot (bottom) – (x8 electrical, x8 mechanical)</li> <li>PCIe_SSD_2-3 Slot (top) – (x8 electrical, x8 mechanical)</li> </ul> <p><b>Kit includes:</b>  (1) – Riser card</p>

## 5.1.2 2U Riser Card Options

Table 28. 2U Riser Card Options

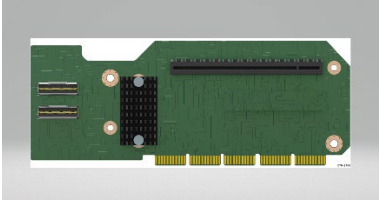
Image	Details	Description
	<p><b>2U 3-Slot PCIe* Riser Card for Riser Slot #1</b></p> <p><b>iPC</b> CYP2URISER1STD  <b>MM#</b> 99A3P4  <b>UPC</b> 00735858471695  <b>EAN</b> 5032037210133  <b>MOQ</b> 1</p> <p><b>Product type</b> 2U building  block/spare FRU  2U accessory kit</p>	<p>Riser card option for Riser Slot #1 only.</p> <p>The three-slot PCIe riser card option supports:</p> <ul style="list-style-type: none"> <li>Slot 1 (top) – One full-height/full-length single-width add-in card slot (x16 electrical, x16 mechanical)</li> <li>Slot 2 (middle) – One full-height/full-length single-width add-in card slot (x8 electrical, x16 mechanical)</li> <li>Slot 3 (bottom) – One full-height/half-length single-width add-in card slot (x8 electrical, x8 mechanical)</li> </ul> <p><b>Kit includes:</b>  (1) – Riser card</p>
	<p><b>2U 2-Slot PCIe* Riser Card for Riser Slot #1</b></p> <p><b>iPC</b> CYP2URISER1DBL  <b>MM#</b> 99A3P5  <b>UPC</b> 00735858471701  <b>EAN</b> 5032037210140  <b>MOQ</b> 1</p> <p><b>Product type</b> 2U building  block/spare FRU  2U accessory kit</p>	<p>Riser card option for Riser Slot #1 only.</p> <p>The two-slot PCIe riser card option supports:</p> <ul style="list-style-type: none"> <li>Slot 1 (top) – One full-height/full-length double-width slot (x16 electrical, x16 mechanical)</li> <li>Slot 2 (bottom) – One full-height/half-length single-width slot (x16 electrical, x16 mechanical)</li> </ul> <p><b>Kit includes:</b>  (1) – Riser card</p>
	<p><b>2U PCIe* NVMe* Riser Card for Riser Slot #1</b></p> <p><b>iPC</b> CYP2URISER1RTM  <b>MM#</b> 99A3P3  <b>UPC</b> 00735858471688  <b>EAN</b> 5032037210126  <b>MOQ</b> 1</p> <p><b>Product type</b> 2U building  block/spare FRU  2U accessory kit</p>	<p>Riser card option for Riser Slot #1 only.</p> <p>The PCIe NVMe riser card option supports:</p> <ul style="list-style-type: none"> <li>Slot 3 (top) – One half-length or full-length single-width slot (x16 electrical, x16 mechanical)</li> <li>Two x8 PCIe NVMe SlimSAS connectors <ul style="list-style-type: none"> <li>- PCIe_SSD_0-1 (top) – (x8 electrical, x8 mechanical)</li> <li>- PCIe_SSD_2-3 (bottom) – (x8 electrical, x8 mechanical)</li> </ul> </li> </ul> <p><b>Kit includes:</b>  (1) – Riser card</p>

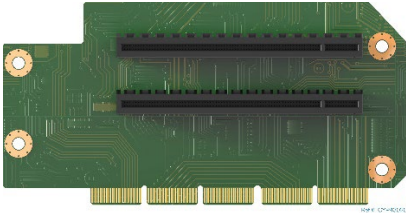
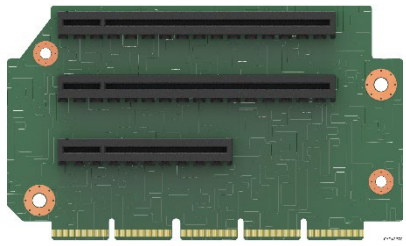
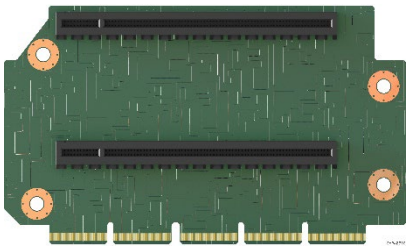
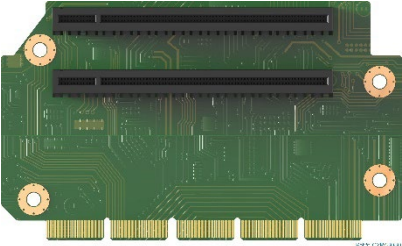
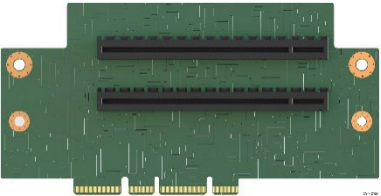

Image	Details	Description
	<p><b>2U 2-Slot PCIe* Riser Card for Riser Slot #1</b></p> <p><b>iPC</b> CYP2URISER1SNL  <b>MM#</b> 99AM7W  <b>UPC</b> 735858507448  <b>EAN</b> 5032037241557  <b>MOQ</b> 1</p> <p><b>Product type</b> 2U building block/spare FRU                  2U accessory kit</p>	<p>Riser card option for Riser Slot #1 only.</p> <p>The two slot PCIe Riser Card option supports:</p> <ul style="list-style-type: none"> <li>Slot 1 (top) – One full-height/full-length single-width slot (x16 electrical, x16 mechanical)</li> <li>Slot 1 (bottom) – One full-height/full-length single-width slot (x16 electrical, x16 mechanical)</li> </ul> <p><b>Kit includes:</b>                  (1) – Riser card</p>
	<p><b>2U 3-Slot PCIe* Riser Card for Riser Slot #2</b></p> <p><b>iPC</b> CYP2URISER2STD  <b>MM#</b> 99A3P6  <b>UPC</b> 00735858471718  <b>EAN</b> 5032037210157  <b>MOQ</b> 1</p> <p><b>Product type</b> 2U building block/spare FRU                  2U accessory kit</p>	<p>Riser card option for Riser Slot #2 only.</p> <p>The three slot PCIe Riser Card option supports:</p> <ul style="list-style-type: none"> <li>Slot 1 (top) – One full-height/full-length single-width slot (x16 electrical, x16 mechanical)</li> <li>Slot 2 (middle) – One full-height/full-length single-width slot (x8 electrical, x16 mechanical)</li> <li>Slot 3 (bottom) – One full-height/half-length single-width slot (x8 electrical, x8 mechanical)</li> </ul> <p><b>Kit includes:</b>                  (1) – Riser card</p>
	<p><b>2U 2-Slot PCIe* Riser Card for Riser Slot #2</b></p> <p><b>iPC</b> CYP2URISER2DBL  <b>MM#</b> 99A3P7  <b>UPC</b> 00735858471725  <b>EAN</b> 5032037210164  <b>MOQ</b> 1</p> <p><b>Product type</b> 2U building block/spare FRU                  2U accessory kit</p>	<p>Riser card option for Riser Slot #2 only.</p> <p>The two slot PCIe Riser Card option supports:</p> <ul style="list-style-type: none"> <li>Slot 1 (top) – One full-height/full-length double-width slot (x16 electrical, x16 mechanical)</li> <li>Slot 2 (bottom) – One full-height/half-length single-width slot (x16 electrical, x16 mechanical)</li> </ul> <p><b>Kit includes:</b>                  (1) – Riser card</p>

Image	Details	Description
	<p><b>2U 2-Slot PCIe* Riser Card for Riser Slot #2</b></p> <p><b>iPC</b> CYP2URISER2SNL  <b>MM#</b> 99AM87  <b>UPC</b> 735858507431  <b>EAN</b> 5032037241540  <b>MOQ</b> 1</p> <p><b>Product type</b> 2U building block/spare FRU                  2U accessory kit</p>	<p>Riser card option for Riser Slot #2 only.</p> <p>The two slot PCIe Riser Card option supports:</p> <ul style="list-style-type: none"> <li>Slot 1 (top) – One full-height/full-length single-width slot (x16 electrical, x16 mechanical)</li> <li>Slot 1 (bottom) – One full-height/full-length single-width slot (x16 electrical, x16 mechanical)</li> </ul> <p><b>Kit includes:</b>                  (1) – Riser card</p>
	<p><b>2U 2-Slot PCIe* Riser Card for Riser Slot #3</b></p> <p><b>iPC</b> CYP2URISER3STD  <b>MM#</b> 99A3P8  <b>UPC</b> 00735858471732  <b>EAN</b> 5032037210171  <b>MOQ</b> 1</p> <p><b>Product type</b> 2U building block/spare FRU                  2U accessory kit</p>	<p>Riser card option for Riser Slot #3 only.</p> <p>The two slot PCIe riser card option supports:</p> <ul style="list-style-type: none"> <li>Slot 1 (top) – low profile/ half-length single-width slots (x8 electrical, x16 mechanical)</li> <li>Slot 2 (bottom) – low profile/ half-length single-width slots (x8 electrical, x16 mechanical)</li> </ul> <p><b>Kit includes:</b>                  (1) – Riser card</p>
	<p><b>2U/1U 2-Slot PCIe* NVMe* Riser Card for Riser Slot #3</b></p> <p><b>iPC</b> CYPRISER3RTM  <b>MM#</b> 99A3PA  <b>UPC</b> 00735858471763  <b>EAN</b> 5032037210201  <b>MOQ</b> 1</p> <p><b>Product type</b> 2U/1U building block/spare FRU                  2U/1U accessory kit</p>	<p>Riser card option for Riser Slot #3 only.</p> <p>The two slot PCIe NVMe riser card option supports:</p> <ul style="list-style-type: none"> <li>PCIe_SSD_0-1 (bottom) – (x8 electrical, x8 mechanical)</li> <li>PCIe_SSD_2-3 (top) – (x8 electrical, x8 mechanical)</li> </ul> <p><b>Kit includes:</b>                  (1) Riser card</p>

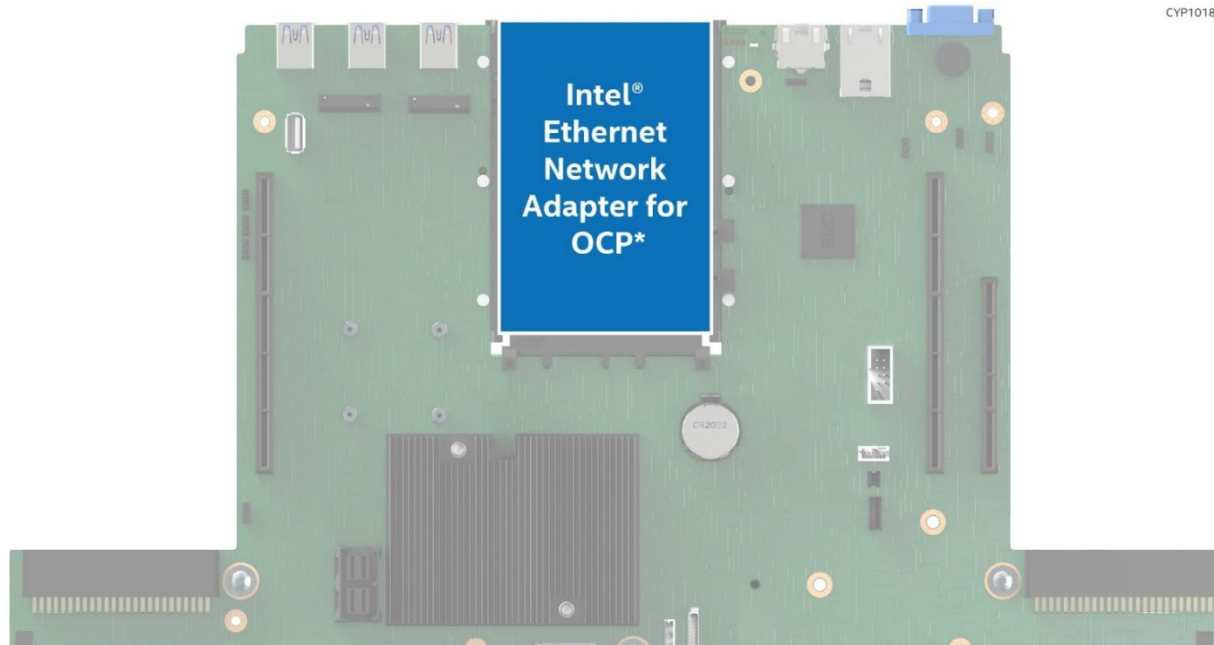
## 5.2 Intel® Ethernet Network Adapters for OCP\*

The server system supports several types of Intel Ethernet Network Adapters (see [Table 29](#)). These adapters are compatible with the Open Compute Project\* (OCP\*) 3.0 specification. The OCP-compatible modules are mounted to a high-density 168-pin mezzanine connector on the server board labeled “OCP\_IO\_Module”. The following figure shows the Intel Ethernet Network Adapter placement on the server board.

---

**Note:** The Intel Server M50CYP Family only supports the Intel Ethernet Network Adapters for OCP that are listed in [Table 29](#).

---

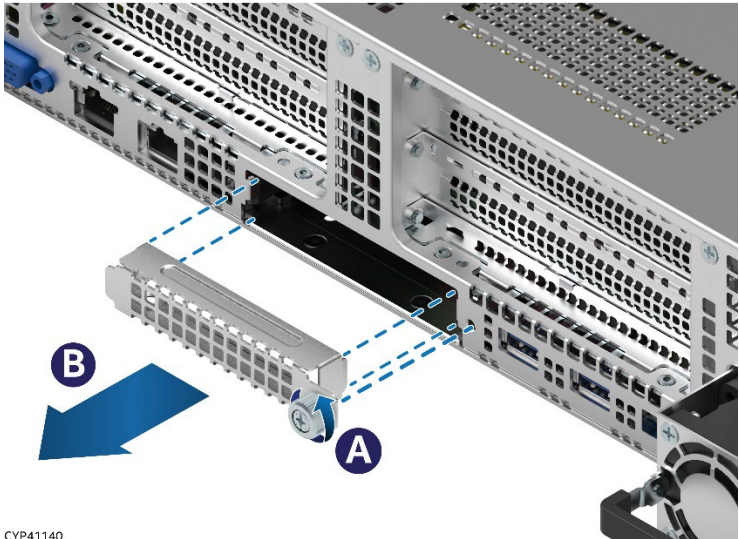


**Figure 30. Intel® Ethernet Network Adapter Placement**

All Intel Ethernet Network Adapter OCP types support one of the three engagement mechanisms: pull tab, ejector latch, and internal lock. The engagement mechanism refers to the mechanism required to install / remove the OCP module.

Intel Ethernet Network Adapters supported by the Intel Server M50CYP Family are installed into an OCP bay in the back of the server chassis. The adapter is installed from the outside of the chassis. The following figures show the installation of the pull tab engagement mechanism.

First remove the bay filler panel (see [Figure 31](#)). Then, carefully slide the module into the bay until it is fully seated in the OCP slot on the server board and is locked in place (see [Figure 32](#)). For more information on OCP module installation and removal of each OCP module type, see the *Intel® Server System M50CYP2UR System Integration and Service Guide* or *Intel® Server System M50CYP1UR System Integration and Service Guide*.



CYP41140




Figure 31. OCP\* Module Bay Filler Removal (2U System Shown)






CYP41180

Figure 32. OCP\* Module with Pull tab Installation (2U System Shown)

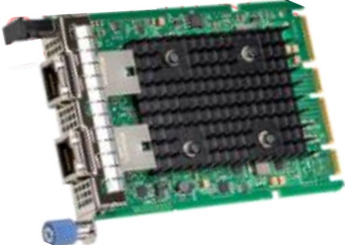

**Table 29. Intel® Ethernet Network Adapters for OCP\***

Image	Details	Description
	<p><b>Intel® Ethernet Network Adapter E810-CQDA2 for OCP 3.0</b></p> <p><b>iPC</b> E810CQDA1OCPV3  <b>MM#</b> 983092  <b>UPC</b> 00735858461115  <b>EAN</b> 5032037200639  <b>MOQ</b> 1</p> <p><b>Product type</b> 1U/2U accessory kit</p>	<ul style="list-style-type: none"> <li>• Single port, QSFP28, 100/50/25/10 GbE OCP 3.0 Module</li> <li>• Connects to server board using Mezzanine Connector</li> <li>• Supports PCIe x16 Gen 4.0 lanes</li> <li>• Supports Pull Tab module installation/removal mechanism</li> <li>• Concurrent RDMA (iWARP and RoCEv2) support</li> <li>• Data Plane Development Kit (DPDK) Optimized</li> <li>• Application Device Queues (ADQ) support</li> <li>• Extensive Network Virtualization Overlay protocol support</li> <li>• Enhanced QoS and Access Control List (ACL) support</li> </ul>
	<p><b>Intel® Ethernet Network Adapter E810-CQDA2 for OCP 3.0</b></p> <p><b>iPC</b> E810CQDA2OCPV3  <b>MM#</b> 983581  <b>UPC</b> 00735858456883  <b>EAN</b> 5032037196512  <b>MOQ</b> 1</p> <p><b>Product type</b> 1U/2U accessory kit</p>	<ul style="list-style-type: none"> <li>• Dual port, QSFP28, 100/50/25/10 GbE OCP 3.0 Module</li> <li>• Connects to server board using Mezzanine Connector</li> <li>• Supports PCIe x16 Gen 4.0 lanes</li> <li>• Supports Pull Tab module installation/removal mechanism</li> <li>• Concurrent RDMA (iWARP and RoCEv2) support</li> <li>• Data Plane Development Kit (DPDK) Optimized</li> <li>• Application Device Queues (ADQ) support</li> <li>• Extensive Network Virtualization Overlay protocol support</li> <li>• Enhanced QoS and Access Control List (ACL) support</li> </ul>
	<p><b>Intel Ethernet Network Adapter E810-XXVDA2 for OCP 3.0</b></p> <p><b>iPC</b> E810XXVDA2OCPV3  <b>MM#</b> 983262  <b>UPC</b> 00735858452977  <b>EAN</b> 5032037193238  <b>MOQ</b> 1</p> <p><b>Product type</b> 1U/2U accessory kit</p>	<ul style="list-style-type: none"> <li>• Dual port, SFP28, 25/10 GbE OCP 3.0 Module</li> <li>• Connects to server board using Mezzanine Connector</li> <li>• Supports PCIe x16 Gen 4.0 lanes</li> <li>• Concurrent RDMA (iWARP and RoCEv2) support</li> <li>• Data Plane Development Kit (DPDK) Optimized</li> <li>• Application Device Queues (ADQ) support</li> <li>• Extensive Network Virtualization Overlay protocol support</li> <li>• Enhanced QoS and Access Control List (ACL) support</li> </ul>

## Intel® Server M50CYP Family Configuration Guide

Image	Details	Description
	<p><b>Intel Ethernet Network Adapter E810-XXVDA2 for OCP 3.0</b></p> <p>iPC E810XXVDA40CPV3            MM# 983099            UPC 0735858489546            EAN 5032037225786            MOQ 1</p> <p><b>Product type</b> 1U/2U accessory kit</p>	<ul style="list-style-type: none"> <li>• Quad port, SFP28, 25/10 GbE OCP 3.0 Module</li> <li>• Connects to server board using Mezzanine Connector</li> <li>• Supports PCIe x16 Gen 4.0 lanes</li> <li>• Concurrent RDMA (iWARP and RoCEv2) support</li> <li>• Data Plane Development Kit (DPDK) Optimized</li> <li>• Application Device Queues (ADQ) support</li> <li>• Extensive Network Virtualization Overlay protocol support</li> <li>• Enhanced QoS and Access Control List (ACL) support</li> </ul>
	<p><b>Intel® Ethernet Network Adapter X710 for OCP 3.0</b></p> <p>iPC X710DA20CPV3            MM# 979095            UPC 00735858421232            EAN 5032037163743            MOQ 1</p> <p><b>Product type</b> 1U/2U accessory kit</p>	<ul style="list-style-type: none"> <li>• Dual port, SFP+ DA, 2X 10 GbE OCP 3.0 Module</li> <li>• Connects to server board using Mezzanine Connector</li> <li>• Supports PCIe x16 Gen 3.0 lanes</li> <li>• Supports Pull Tab module installation/removal mechanism</li> <li>• Network Virtualization (VxLAN, GENEVE, NVGRE, MPLS, and VXLAN-GPE with NSH) support</li> <li>• Intel® Ethernet Flow Director (Intel® Ethernet FD) support for hardware-based application traffic steering</li> <li>• Data Plane Development Kit (DPDK) Optimized</li> </ul>
	<p><b>Intel® Ethernet Network Adapter X710 for OCP 3.0</b></p> <p>iPC X710DA40CPV3            MM# 979098            UPC 00735858421195            EAN 5032037163705            MOQ 1</p> <p><b>Product type</b> 1U/2U accessory kit</p>	<ul style="list-style-type: none"> <li>• Quad port, SFP+ DA, 2X 10 GbE OCP 3.0 Module</li> <li>• Connects to server board using Mezzanine Connector</li> <li>• Supports PCIe x16 Gen 3.0 lanes</li> <li>• Supports Pull Tab module installation/removal mechanism</li> <li>• Network Virtualization (VxLAN, GENEVE, NVGRE, MPLS, and VXLAN-GPE with NSH) support</li> <li>• Intel Ethernet FD support for hardware-based application traffic steering</li> <li>• Data Plane Development Kit (DPDK) Optimized</li> </ul>

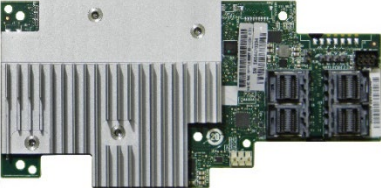
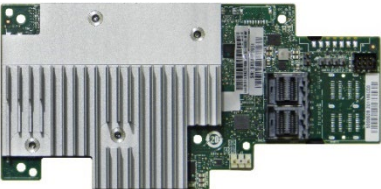
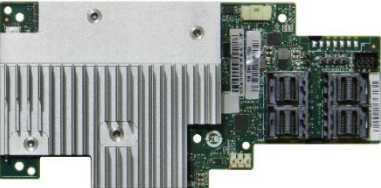
## Intel® Server M50CYP Family Configuration Guide

Image	Details	Description
	<p><b>Intel® Ethernet Network Adapter X710-T2L for OCP 3.0</b></p> <p><b>iPC</b> X710T2LOCPV3  <b>MM#</b> 9999MJ  <b>UPC</b> 00735858447027  <b>EAN</b> 5032037188111  <b>MOQ</b> 1</p> <p><b>Product type</b> 1U/2U accessory kit</p>	<ul style="list-style-type: none"> <li>• Dual port, RJ45, 10/1 GbE OCP 3.0 Module</li> <li>• Connects to server board using Mezzanine Connector</li> <li>• Supports PCIe x16 Gen 3.0 lanes</li> <li>• Supports Pull Tab module installation/removal mechanism</li> <li>• Network Virtualization (VxLAN, GENEVE, NVGRE, MPLS, and VXLAN-GPE with NSH) support</li> <li>• Intel Ethernet FD support for hardware-based application traffic steering</li> <li>• Data Plane Development Kit (DPDK) Optimized</li> </ul>
	<p><b>Intel® Ethernet Network Adapter X710-T4L for OCP 3.0</b></p> <p><b>iPC</b> X710T4LOCPV3  <b>MM#</b> 9999ML  <b>UPC</b> 00735858450010  <b>EAN</b> 5032037190619  <b>MOQ</b> 1</p> <p><b>Product type</b> 1U/2U accessory kit</p>	<ul style="list-style-type: none"> <li>• Quad port, RJ45, 10/1 GbE OCP 3.0 Module</li> <li>• Connects to server board using Mezzanine Connector</li> <li>• Supports PCIe x16 Gen 3.0 lanes</li> <li>• Supports Pull Tab module installation/removal mechanism</li> <li>• Network Virtualization (VxLAN, GENEVE, NVGRE, MPLS, and VXLAN-GPE with NSH) support</li> <li>• Intel Ethernet FD support for hardware-based application traffic steering</li> <li>• Data Plane Development Kit (DPDK) Optimized</li> </ul>


## 5.3 Intel® RAID Add-in Cards, Modules, and Accessories

### 5.3.1 Intel® Integrated RAID Module RMSP3 Product Family

Table 30. Intel® Integrated RAID Module RMSP3 Product Family – SAS 3.0 (12 Gb/s) and PCIe 3.0

Image	Details	Description
	<p><b>Intel® Integrated Storage Module RMSP3JD160J</b></p> <p><b>iPC</b> RMSP3JD160J  <b>MM#</b> 954490  <b>UPC</b> 00735858329118  <b>EAN</b> 5032037095235  <b>MOQ</b> 5</p> <p><b>Product type</b> 1U/2U accessory kit</p>	<p>Mezzanine Form Factor Storage Module                      Entry Level SAS Storage Controller                      16 internal SAS / SATA ports                      Avago* SAS3516 IOC                      Storage Levels – JBOD (SAS/SATA Connectivity)</p> <p>SAS data cables not included and must be purchased separately.</p>
	<p><b>Intel® Integrated RAID Module RMSP3HD080E</b></p> <p><b>iPC</b> RMSP3HD080E  <b>MM#</b> 954553  <b>UPC</b> 00735858329125  <b>EAN</b> 5032037095242  <b>MOQ</b> 5</p> <p><b>Product type</b> 1U/2U accessory kit</p>	<p>Mezzanine Form Factor RAID Module                      Entry level RAID Module                      8 internal SAS / SATA ports                      Avago SAS3408 IOC                      RAID Levels – 0/1/10/5 and JBOD</p> <p>SAS data cables not included and must be purchased separately.</p>
	<p><b>Intel® Integrated RAID Module RMSP3AD160F</b></p> <p><b>iPC</b> RMSP3AD160F  <b>MM#</b> 954552  <b>UPC</b> 00735858329149  <b>EAN</b> 5032037095266  <b>MOQ</b> 5</p> <p><b>Product type</b> 1U/2U accessory kit</p>	<p>Mezzanine Form Factor RAID Module                      Full Featured RAID Controller                      16 internal SAS / SATA ports                      Avago SAS3516 ROC                      RAID Levels – 0/1/10/5/6/50/60 and JBOD                      Supports Maintenance Free Backup Unit – iPC <b>AXXRMFBU7</b>                      Supports the following Intel RAID accessory option:</p> <ul style="list-style-type: none"> <li>Intel® RAID Drive Encryption Management – iPC <b>AXXRPFKDE2</b></li> </ul> <p>SAS data cables not included and must be purchased separately.</p>

Intel® Server M50CYP Family Configuration Guide

Image	Details	Description
	<p><b>Intel® Integrated RAID Module</b> <b>RMSP3CD080F</b></p> <p><b>iPC</b> RMSP3CD080F  <b>MM#</b> 954489  <b>UPC</b> 00735858329132  <b>EAN</b> 5032037095259  <b>MOQ</b> 5</p> <p><b>Product type</b> 1U/2U accessory kit</p>	<p>Mezzanine Form Factor RAID Module            Full Featured RAID Controller            8 internal SAS / SATA ports            Avago SAS3508 ROC            RAID Levels – 0/1/10/5/6/50/60 and JBOD            Supports Maintenance Free Backup Unit – iPC <b>AXXRMFBU7</b>            Supports Intel RAID Drive Encryption Management – iPC <b>AXXRPFKDE2</b></p> <p>SAS data cables not included and must be purchased separately.</p>

5.3.2 Intel® RAID Controller Add-in Cards

Table 31. Intel® RAID Controller Add-in Cards – SAS 3.0 (12 Gb/s) and PCIe 3.0


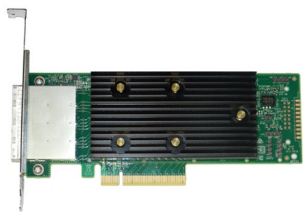
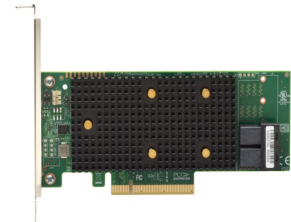
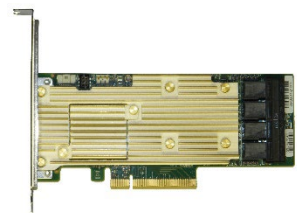

Image	Details	Description
	<p><b>Intel® Storage Controller RSP3QD160J</b></p> <p><b>iPC</b> RSP3QD160J  <b>MM#</b> 954491  <b>UPC</b> 00735858329101  <b>EAN</b> 5032037095228  <b>MOQ</b> 5</p> <p><b>Product type</b> 2U accessory kit</p>	<p>Low Profile, half length, (MD2 Compliant) PCIe add-in card                      Entry level SAS/SATA adapter.                      16 internal SAS / SATA ports                      Avago SAS3416 IOC                      JBOD (SAS/SATA Connectivity)</p> <p>SAS data cables not included and must be purchased separately.</p>
	<p><b>Intel® Storage Controller RSP3GD016J</b></p> <p><b>iPC</b> RSP3GD016J  <b>MM#</b> 954492  <b>UPC</b> 00735858329156  <b>EAN</b> 5032037095273  <b>MOQ</b> 5</p> <p><b>Product type</b> 2U accessory kit</p>	<p>Low Profile, half length, (MD2 Compliant) PCIe add-in card                      Entry level SAS/SATA adapter.                      16 external SAS / SATA ports                      Avago SAS3416 IOC                      JBOD (SAS/SATA Connectivity)</p> <p>SAS data cables not included and must be purchased separately.</p>
	<p><b>Intel® RAID Controller RSP3WD080E</b></p> <p><b>iPC</b> RSP3WD080E  <b>MM#</b> 954495  <b>UPC</b> 00735858329170  <b>EAN</b> 5032037095297  <b>MOQ</b> 5</p> <p><b>Product type</b> 2U accessory kit</p>	<p>Low Profile, half length, (MD2 Compliant) PCIe add-in card                      Entry Level SAS/SATA RAID Controller                      8 internal SAS/SATA ports                      Avago SAS3408 ROC                      RAID Levels – 0/1/10/5 and JBOD</p> <p>SAS data cables not included and must be purchased separately.</p>
	<p><b>Intel® RAID Controller RSP3TD160F</b></p> <p><b>iPC</b> RSP3TD160F  <b>MM#</b> 954493  <b>UPC</b> 00735858329163  <b>EAN</b> 5032037095280  <b>MOQ</b> 5</p> <p><b>Product type</b> 2U accessory kit</p>	<p>Low Profile, half length, (MD2 Compliant) PCIe add-in card                      Full Featured SAS/SATA RAID Controller                      16 internal SAS/SATA ports                      Avago SAS3516 ROC                      RAID Levels – 0/1/10/5/6/50/60 and JBOD                      Supports Maintenance Free Backup Unit – iPC <b>AXXRMFBU7</b></p> <p>SAS data cables not included and must be purchased separately.</p>

Image	Details	Description
	<p><b>Intel® RAID Controller RSP3MD088F</b></p> <p><b>iPC</b> RSP3MD088F  <b>MM#</b> 954551  <b>UPC</b> 00735858329194  <b>EAN</b> 5032037095310  <b>MOQ</b> 5</p> <p><b>Product type</b> 2U accessory kit</p>	<p>Low Profile, half length, (MD2 Compliant) PCIe add-in card                      Full Featured SAS/SATA RAID Controller                      8 internal SAS/SATA ports                      8 external SAS ports                      Avago SAS3516 ROC                      RAID Levels – 0/1/10/5/6/50/60 and JBOD                      Supports Maintenance Free Backup Unit – iPC <b>AXXRMFBU7</b></p> <p>SAS data cables not included and must be purchased separately.</p>

**Table 32. Intel® RAID Controller Add-in Cards – SAS 3.0 (12 Gb/s) and NVMe\* PCIe\* 4.0**



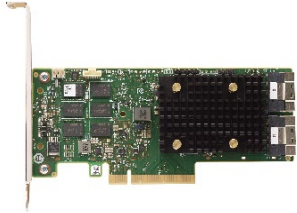
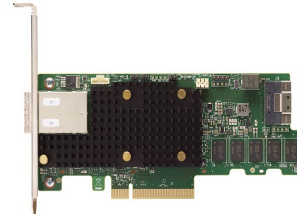
Image	Details	Description
	<p><b>Intel® Storage Controller RS3P4QF160J</b></p> <p><b>iPC</b> RS3P4QF160J  <b>MM#</b> 999RKM  <b>UPC</b> 00735858452830  <b>EAN</b> 5032037193115  <b>MOQ</b> 5</p> <p><b>Product type</b> 1U/2U accessory kit</p>	<p>Low Profile, half length, (MD2 Compliant) PCIe add-in card                      Entry level Tri-Mode SAS/SATA/NVMe adapter.                      16 internal SAS / SATA ports / 4 NVMe (PCIe gen4)                      Broadcom* SAS3816 IOC                      JBOD (SAS/SATA/NVMe Connectivity)</p> <p>SAS and NVMe data cables not included and must be purchased separately.</p>
	<p><b>Intel® Storage Controller RS3P4GF016J</b></p> <p><b>iPC</b> RS3P4GF016J  <b>MM#</b> 999TJ3  <b>UPC</b> 00735858452823  <b>EAN</b> 5032037193108  <b>MOQ</b> 5</p> <p><b>Product type</b> 1U/2U accessory kit</p>	<p>Low Profile, half length, (MD2 Compliant) PCIe add-in card                      Entry level Tri-Mode SAS/SATA/NVMe adapter.                      16 external SAS / SATA ports                      Broadcom SAS3816 IOC                      JBOD (SAS/SATA Connectivity)</p> <p>SAS data cables not included and must be purchased separately.</p>

Image	Details	Description
	<p><b>Intel® RAID Controller RS3P4TF160F</b></p> <p><b>iPC</b> RS3P4TF160F  <b>MM#</b> 999TJ4  <b>UPC</b> 00735858452816  <b>EAN</b> 5032037193092  <b>MOQ</b> 5</p> <p><b>Product type</b> 1U/2U accessory kit</p>	<p>Low Profile, half length, (MD2 Compliant) PCIe add-in card                      Full Featured Tri-Mode RAID Controller                      16 internal SAS / SATA ports / 4 NVMe (PCIe 4.0)                      Broadcom SAS3916 ROC                      RAID Levels – 0/1/10/5/6/50/60 and JBOD                      Supports Maintenance Free Backup Unit – iPC <b>AXXRMFBU7</b></p> <p>SAS and NVMe data cables not included and must be purchased separately.</p>
	<p><b>Intel® RAID Controller RS3P4MF088F</b></p> <p><b>iPC</b> RS3P4MF088F  <b>MM#</b> 99ADDX  <b>UPC</b> 00735858486590  <b>EAN</b> 5032037223287  <b>MOQ</b> 5</p> <p><b>Product type</b> 1U/2U accessory kit</p>	<p>Low Profile, half length, (MD2 Compliant) PCIe add-in card                      Full Featured Tri-Mode RAID Controller                      8 internal SAS / SATA ports                      8 external SAS                      Broadcom SAS3916 ROC                      RAID Levels – 0/1/10/5/6/50/60 and JBOD                      Supports Maintenance Free Backup Unit – iPC <b>AXXRMFBU7</b></p> <p>SAS and NVMe data cables not included and must be purchased separately.</p>

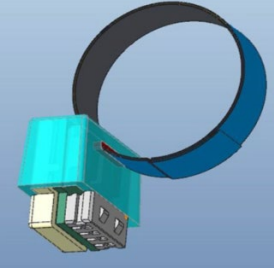
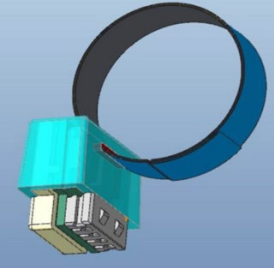
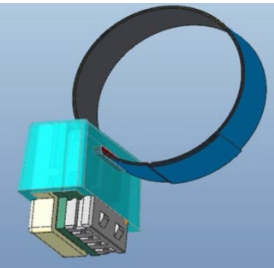
### 5.3.3 Intel® VROC Keys

Three supported types of Intel VROC Keys are shown in the following table.

**Table 33. Optional VROC 7.5 Upgrade Key - Supported NVMe\* RAID Features**



NVMe* RAID Major Features	Standard Intel® VROC 7.5 Key (iPC VROCSTANMOD)	Premium Intel® VROC 7.5 Key (iPC VROCPREMMOD)	Intel® SSD Only VROC 7.5 Key (iPC VROCISSDMOD)
<b>Processor-attached NVMe* SSD – high performance</b>	Yes	Yes	Yes
<b>Boot on RAID volume</b>	Yes	Yes	Yes
<b>Third party vendor SSD support</b>	Yes	Yes	No
<b>RAID 0/1/10</b>	Yes	Yes	Yes
<b>RAID 0/1/5/10</b>	No	Yes	Yes
<b>RAID write hole closed (RMFBU replacement)</b>	No	Yes	Yes
<b>Hot plug/ surprise removal (2.5" SSD form factor only)</b>	Yes	Yes	Yes
<b>Enclosure LED management</b>	Yes	Yes	Yes

**Table 34. Intel® VROC Key Option**

Image	Details	Description
	<p><b>Standard Intel® VROC Key</b></p> <p><b>iPC</b> VROCSTANMOD  <b>MM#</b> 951605  <b>UPC</b> 00735858337243  <b>EAN</b> 5032037100007  <b>MOQ</b> 1</p> <p><b>Product type</b> 1U/2U building block/spare FRU  1U/2U accessory kit</p>	<p><b>Intel® VROC 7.5 Key for 1U/2U systems</b></p> <p><b>Kit includes:</b>  (1) – Standard Intel VROC 7.5 key</p>
	<p><b>Premium Intel® VROC Key</b></p> <p><b>iPC</b> VROCPREMMOD  <b>MM#</b> 951606  <b>UPC</b> 00735858337267  <b>EAN</b> 5032037100014  <b>MOQ</b> 1</p> <p><b>Product type</b> 1U/2U building block/spare FRU  1U/2U accessory kit</p>	<p><b>Intel® VROC 7.5 Key for 1U/2U systems</b></p> <p><b>Kit includes:</b>  (1) – Premium Intel VROC 7.5 key</p>
	<p><b>Intel® SSD Only VROC Key</b></p> <p><b>iPC</b> VROCISSDMOD  <b>MM#</b> 956822  <b>UPC</b> 00735858337274  <b>EAN</b> 5032037100021  <b>MOQ</b> 1</p> <p><b>Product type</b> 1U/2U building block/spare FRU  1U/2U accessory kit</p>	<p><b>Intel® VROC 7.5 Key for 1U/2U systems</b></p> <p><b>Kit includes:</b>  (1) – Intel VROC 7.5 key (SSD only)</p>

5.3.4 Miscellaneous Intel® RAID Accessory Options

Table 35. Intel® RAID Accessory Options

Image	Details	Description
	<p><b>Intel® RAID Maintenance Free Backup Unit AXRMFBU7</b></p> <p><b>iPC</b> AXRMFBU7  <b>MM#</b> 957677  <b>UPC</b> 00735858336192  <b>EAN</b> 5032037099790  <b>MOQ</b> 5</p> <p><b>Product type</b> 1U/2U accessory kit</p>	<p>A super-capacitor module designed to protect data in dynamic memory during a power failure or system crash event. The AXRMFBU7 is used with the full-featured tri-mode RAID modules and controllers.</p> <p>Compatible with:</p> <ul style="list-style-type: none"> <li>• Intel® Integrated RAID Module RMSP3AD160F</li> <li>• Intel® Integrated RAID Module RMSP3CD080F</li> <li>• Intel® RAID Controller RSP3TD160F                             <ul style="list-style-type: none"> <li>• Intel® RAID Controller RSP3DD080F</li> <li>• Intel® RAID Controller RSP3MD088F</li> <li>• Intel® RAID Controller RS3P4TF160F</li> <li>• Intel® RAID Controller RS3P4MF088F</li> </ul> </li> </ul>
	<p><b>Intel® RAID Drive Encryption Management</b></p> <p><b>iPC</b> AXRPFKDE2  <b>MM#</b> 915317  <b>UPC</b> 00735858221474  <b>EAN</b> 5032037051705  <b>MOQ</b> 5</p> <p><b>Product type</b> 1U/2U accessory kit</p>	<p>Upgrade key to enable drive encryption management for Intel® RAID Controllers RSP3TD160F, RSP3MD088F, RMSP3AD160F, RMSP3CD080F.</p>

## 5.4 Power Supply Unit Options and Power Cable Kits

**Table 36. Power Supply Modules and Power Cords**

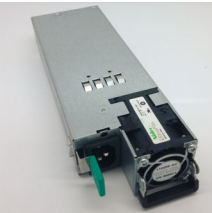


Image	Details	Description
	<p><b>2100 W AC Common Redundant Power Supply</b></p> <p><b>iPC</b> FCXX2100CRPS  <b>MM#</b> 99C4MW  <b>UPC</b> 00735858424592  <b>EAN</b> 5032037166829  <b>MOQ</b> 1</p> <p><b>Product type</b> 2U building block/spare FRU                  2U accessory kit</p>	<p>2100 W AC common redundant power supply with 80 PLUS* Platinum efficiency. Power cord sold separately.</p>
	<p><b>1600 W AC Common Redundant Power Supply</b></p> <p><b>iPC</b> AXX1600TCRPS  <b>MM#</b> 99ADF2  <b>UPC</b> 00735858407038  <b>EAN</b> 5032037151245  <b>MOQ</b> 1</p> <p><b>Product type</b> 1U/2U building block/spare FRU                  1U/2U accessory kit</p>	<p>1600 W AC common redundant power supply with 80 PLUS Titanium efficiency. Power cord sold separately.</p>
	<p><b>1300 W AC Common Redundant Power Supply</b></p> <p><b>iPC</b> AXX1300TCRPS  <b>MM#</b> 956542  <b>UPC</b> 00735858345705  <b>EAN</b> 5032037106191  <b>MOQ</b> 1</p> <p><b>Product type</b> 1U/2U building block/spare FRU                  1U/2U accessory kit</p>	<p>1300 W AC common redundant power supply with 80 PLUS Titanium efficiency. Power cord sold separately.</p>





Image	Details	Description
	<p><b>1500 mm (59 in) North America power cable</b></p> <p><b>iPC</b> FPWRCABLENA  <b>MM#</b> 879287  <b>UPC</b> 00735858181129  <b>EAN</b> 5032037015738  <b>MOQ</b> 1</p> <p><b>Product type</b> 1U/2U spare FRU  1U/2U accessory kit</p>	<p>1500 mm (59 in) North America power cable</p>
	<p><b>Kit to support 2 internal SATA SSDs</b></p> <p><b>iPC</b> CYPCLINTSTKIT  <b>MM#</b> 99A5A1  <b>UPC</b> 00735858471619  <b>EAN</b> 5032037210058  <b>MOQ</b> 1</p> <p><b>Product type</b> 2U accessory kit</p>	<p>Used in 2U systems to connect server board Mini-SAS HD to internal SATA SSDs.</p> <p><b>Kit Includes:</b></p> <ul style="list-style-type: none"> <li>• (1) – <b>175 mm</b> cable, server board Mini-SAS HD connectors to internal 7-pin SATA SSD (2 ports) (RA to VT)</li> <li>• (1) – <b>120/180 mm</b> splitter cable, 2U Power cable for internal SATA. Power cable connects server board 3.3/5/12 V power connector to internal SATA SSD power connectors.</li> <li>• (1) – Sheet metal bracket for internal SATA SSDs</li> </ul>
	<p><b>Kit to support 2 internal SATA SSDs</b></p> <p><b>iPC</b> CYPCLHDINTST  <b>MM#</b> 99AXKD  <b>UPC</b> 00735858518895  <b>EAN</b> 5032037251693  <b>MOQ</b> 1</p> <p><b>Product type</b> 2U accessory kit</p>	<p>Used in 2U systems to connect SAS/RAID controller Mini-SAS HD to internal SATA SSDs.</p> <p><b>Kit Includes:</b></p> <ul style="list-style-type: none"> <li>• (1) – <b>175 mm</b> cable, connects SAS add-in card Mini-SAS HD connector to internal 7-pin SATA SSD (2 ports) (VT to VT)</li> <li>• (1) – <b>120/180 mm</b> splitter cable, 2U Power cable for internal SATA. Power cable connects server board 3.3/5/12 V power connector to internal SATA SSD power connectors.</li> <li>• (1) – Sheet metal bracket for internal SATA SSDs</li> </ul>

Image	Details	Description
	<p><b>IPC</b> CYPCLCOMMKIT  <b>MM#</b> 99A3P1  <b>UPC</b> 00735858475266  <b>EAN</b> 5032037213219  <b>MOQ</b> 1</p>	<p>Low cost cable kit. Used in 1U / 2U systems as spare or accessory.</p> <p><b>Kit Includes:</b></p> <ul style="list-style-type: none"> <li>• (1) – <b>455/565/720 mm</b> splitter cable, 2U Power cable, server board to HSBPs (1, 2, and 3) (2x6 pin to three 2x2 pin)</li> <li>• (1) – <b>445/720 mm</b> splitter cable, 1U/2U Power cable, server board to HSBP (2x3 pin to two 2x2 pin)</li> <li>• (1) – <b>425/660 mm</b> splitter cable, 2U Power cable, server board to 3.5"HSBP (2x6 pin to two 2x2 pin)</li> <li>• (1) – <b>125/355 mm</b> splitter cable, 1U/2U Power cable, server board to Midplane card / SAS Interposer card (2x2 pin to two 2x2 pin)</li> <li>• (1) – <b>598.5 mm</b> cable, Front control panel cable for 2U systems (26 pin)</li> <li>• (1) – <b>597.5 mm</b> cable, Front control panel cable for 1U systems (26 pin)</li> <li>• (1) – <b>601 mm</b> cable, USB 3.0/2.0 cable for front USB panel (26 pin) for 2U and 1U systems</li> <li>• (1) – <b>75 mm</b> cable, HSBP I<sup>2</sup>C connector to Midplane card I<sup>2</sup>C connector (5 pin to 5 pin)</li> <li>• (1) – <b>250 mm</b> cable, server board I<sup>2</sup>C connector (Left of board) to HSBP (Left) I<sup>2</sup>C connector (5 Pin to 5 Pin)</li> <li>• (1) – <b>350 mm</b> cable, server board I<sup>2</sup>C connector (Left) to HSBP I<sup>2</sup>C connector (Middle) (5 pin to 5 pin)</li> <li>• (1) – <b>610 mm</b> cable, server board I<sup>2</sup>C connector (rear) to SAS Interposer card I<sup>2</sup>C connector (10 pin to 10 pin)</li> <li>• (1) – <b>900 mm</b> cable, server board to Front control panel / USB panel (26 pin to 26 pin)</li> <li>• (1) – <b>180 mm</b> cable, server board I<sup>2</sup>C connector to Midplane card I<sup>2</sup>C connector (5 pin to 5 pin)</li> <li>• (1) – <b>90 mm</b> cable, HSBP3 I<sup>2</sup>C connector (right) to Midplane card I<sup>2</sup>C connector (5 pin to 3 pin)</li> <li>• (1) – <b>75 mm</b> cable, I<sup>2</sup>C Jumper Cable (connects Midplane cards) (3 pin to 3 pin)</li> </ul>

## 5.5 1U / 2U Rack Mount Kits

**Advisory Note:** Available rack and cabinet mounting kits are not designed to support shipment of the server system while installed in a rack. If you choose to do so, Intel advises verification of your shipping configuration with appropriate shock and vibration testing before shipment. Intel does not perform shipping tests that cover the complex combination of unique rack offerings and custom packaging options.

**Caution:** Exceeding the specified maximum weight limit of a given rail kit or misalignment of the server in the rack may result in failure of the rack rails, damaging the system or causing personal injury. Using two people or the use of a mechanical assist tool to install and align the server into the rack is highly recommended.

**Caution:** Exceeding the rail kit's specified maximum weight limit or misalignment of the server in the rack may result in failure of the rack rails. This situation could damage the system or cause personal injury. Using two people or the use of a mechanical assist tool to install and align the server into the rack is highly recommended.

**Table 37. Rack Mount Kits**



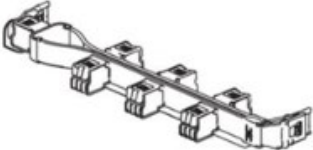


Image	Details	Description
	<p><b>1U/2U Full Extension Rail Kit</b></p> <p><b>iPC</b> CYPFULLEXTRAIL  <b>MM#</b> 999ZCN  <b>UPC</b> 00735858447096  <b>EAN</b> 5032037188180  <b>MOQ</b> 1</p> <p><b>Product type</b> 2U accessory kit</p>	<p><b>CYPFULLEXTRAIL</b> – Premium Rail Kit with cable management arm (CMA) support</p> <ul style="list-style-type: none"> <li>• 1U, 2U compatible</li> <li>• Tool-less installation</li> <li>• Rack installation front and rear post distance adjustment from 623 mm ~ 942 mm</li> <li>• 820 mm travel distance</li> <li>• Full extension from rack</li> <li>• 31 Kg (68.34 lbs.) maximum supported weight</li> <li>• Support for Cable Management Arm AXXCMA2</li> </ul>
	<p><b>1U/2U Half Extension Rail Kit</b></p> <p><b>iPC</b> CYPHALFEXTRAIL  <b>MM#</b> 99A3RR  <b>UPC</b> 00735858456333  <b>EAN</b> 5032037196017  <b>MOQ</b> 1</p> <p><b>Product type</b> 1U/2U accessory kit</p>	<p><b>CYPHALFEXTRAIL</b> –Value Rack Mount Rail Kit</p> <ul style="list-style-type: none"> <li>• 1U, 2U compatible</li> <li>• Tool-less chassis attachment</li> <li>• Tools required to attach rails to rack</li> <li>• Rack installation front and rear post distance adjustment from 660 mm to 838 mm</li> <li>• 560 mm travel distance</li> <li>• Half extension from rack</li> <li>• Support for front cover removal and fan replacement</li> <li>• 31 kg (68.34 lbs.) maximum support weight</li> </ul> <p><b>Note:</b> No cable management arm support.</p>

Image	Details	Description
	<p><b>AXXCMA2 – Cable Management Arm</b></p> <p><b>iPC</b> AXXCMA2  <b>MM#</b> 939211  <b>UPC</b> 00735858292009  <b>EAN</b> 5032037070560  <b>MOQ</b> 1</p> <p><b>Product type</b> 1U/2U accessory kit</p>	<p>Supports CYPFULLEXTRAIL only</p>
	<p><b>2U Bezel Kit</b></p> <p><b>iPC</b> CYP2UBEZEL  <b>MM#</b> 99A5T7  <b>UPC</b> 00735858471657  <b>EAN</b> 5032037210096  <b>MOQ</b> 1</p> <p><b>Product type</b> 2U accessory kit</p>	<p>Bezel kit for Intel Server System M50CYP2UR-based systems.</p> <p><b>Kit Includes:</b>  (1) – 2U Bezel.</p>
	<p><b>1U Bezel Kit</b></p> <p><b>iPC</b> MYP1UBEZEL  <b>MM#</b> 99A2D7  <b>UPC</b> 00735858455244  <b>EAN</b> 5032037195164  <b>MOQ</b> 1</p> <p><b>Product type</b> 1U accessory kit</p>	<p>Bezel kit for Intel Server System M50CYP1UR-based systems.</p> <p><b>Kit Includes:</b>  (1) – 1U Bezel.</p>

## 6. 1U / 2U Miscellaneous Accessory Options

Table 38. Miscellaneous Accessory Options

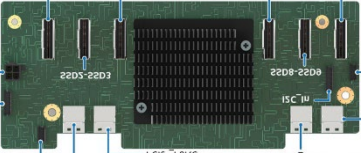
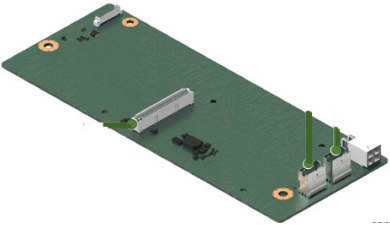
Image	Details	Description
	<p><b>PCIe Midplane Card</b></p> <p><b>iPC</b> CYP SWITCHMP  <b>MM#</b> 99A3PJ  <b>UPC</b> 00735858471824  <b>EAN</b> 5032037210263  <b>MOQ</b> 1</p> <p><b>Product type</b> 2U accessory kit</p>	<p>This kit provides additional NVMe front drive bay support for system configurations having more than eight NVMe drives.</p> <p><b>Kit Includes:</b></p> <ul style="list-style-type: none"> <li>(1) – Midplane card</li> <li>(1) – <b>125/355 mm</b> power cable, server board to Midplane cards (2x2 pin to two 2x2 pin)</li> <li>(1) – <b>75 mm</b> cable, Midplane card (Left) I<sup>2</sup>C connector to Midplane card (Right) I<sup>2</sup>C connector (5 pin to 5 pin)</li> <li>(1) – <b>180 mm</b> cable, server board I<sup>2</sup>C connector to Midplane card (Right) I<sup>2</sup>C connector (5 pin to 5 pin)</li> <li>(1) – <b>90 mm</b> cable, HSBP3 (right) I<sup>2</sup>C connector to Midplane card (Right) I<sup>2</sup>C connector (5 pin to 3 pin)</li> <li>(1) – <b>75 mm</b> cable, connects Midplane card (Left) I<sup>2</sup>C Jumper to Midplane card (Right) I<sup>2</sup>C Jumper (3 pin to 3 pin)</li> </ul> <p><b>Required (sold separately):</b> PCIe Midplane card data cable kit iPC <b>CYPCBLSLMIDPIN</b> and iPC <b>CYPCBLSLMIDPOUT</b>. See Table 25</p>
	<p><b>SAS Interposer Card</b></p> <p><b>iPC</b> CYP SASMODINT  <b>MM#</b> 99A3PX  <b>UPC</b> 00735858471831  <b>EAN</b> 5032037210270  <b>MOQ</b> 1</p> <p><b>Product type</b> 1U/2U accessory kit</p>	<p>This kit provides additional SAS/SATA front drive bay support for system configurations having more than eight SAS/SATA drives.</p> <p><b>Kit Includes:</b></p> <ul style="list-style-type: none"> <li>(1) – SAS Interposer card</li> </ul>




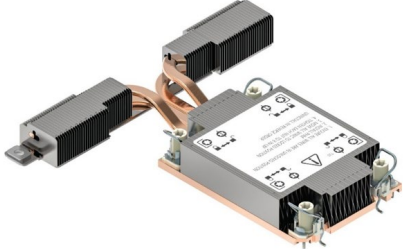
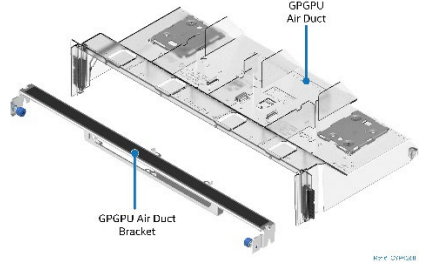
Image	Details	Description
 <p>A photograph of a green SAS expander card with multiple ports and a central component.</p>	<p><b>SAS Expander Card</b></p> <p><b>iPC</b> RES3TV360  <b>MM#</b> 932894  <b>UPC</b> 00735858287364  <b>EAN</b> 5032037067102  <b>MOQ</b> 5</p> <p><b>Product type</b> 2U accessory kit</p>	<p>This kit provides additional SAS/SATA front drive bay support for system configurations having more than 16 SAS/SATA drives. This card is supported only if connected to a SAS/SATA ROC module.</p> <p><b>SAS Expander Card Features:</b></p> <ul style="list-style-type: none"> <li>• SAS 3.0 12 Gb/s Expander card featuring 6 Gbps data aggregation for 12 Gbps data transfer with 6 Gb/s devices</li> <li>• Internal mount midplane form factor</li> <li>• 36 internal ports supporting point-to-point 12, 6, and 3 Gb/s data transfer rates</li> <li>• 4-pin right angle power connector</li> <li>• Mini-SAS HD 8643 connectors</li> </ul> <p><b>Each Kit Includes:</b></p> <p>(1) – SAS expander card  (1) – 130 mm power cable  (4) – 165 mm cable, Expander card HD to HSBP HD  (1) – 300 mm cable, Expander card HD- to HSBP HD  (1) – 250 mm cable, Expander card HD to BP HD  (3) – rubber pads  mounting screws</p> <p><b>Required (sold separately):</b> SAS data cable kit iPC <b>CYPCBLHDHDXXX1</b> – Expander to backplane. See <a href="#">Table 22</a>.</p> <p><b>Note:</b> The onboard SATA ports are not compatible with SAS expander cards. The onboard SATA ports can only be cabled directly to a specified backplane.</p>
 <p>A photograph of a black 2U tall heat sink with multiple cooling fins and mounting brackets.</p>	<p><b>2U Tall Heat Sink</b></p> <p><b>iPC</b> CYP2UHSSTD  <b>MM#</b> 99A3RL  <b>UPC</b> 00735858475259  <b>EAN</b> 5032037213202  <b>MOQ</b> 1</p> <p><b>Product type</b> 2U accessory kit</p>	<p>Spare 2U tall heat sink</p> <p><b>Note:</b> Systems installed with 2U standard heat sink(s) only support half-length add-in cards.</p> <p><b>Includes:</b></p> <p>(1) – 2U tall heat sink</p>

Image	Details	Description
	<p><b>1U Tall Heat Sink</b></p> <p><b>iPC</b> CYP1UHSSTD  <b>MM#</b> 99A3NP  <b>UPC</b> 00735858454735  <b>EAN</b> 5032037194679  <b>MOQ</b> 1</p> <p><b>Product type</b> 1U/2U accessory kit</p>	<p>Spare 1U tall heat sink</p> <p><b>Includes:</b>                      (1) – 1U tall heat sink</p>
	<p><b>1U EVAC Heat Sink</b></p> <p><b>iPC</b> CYP1UHSEVAC  <b>MM#</b> 99A3NV  <b>UPC</b> 00735858471862  <b>EAN</b> 5032037210300  <b>MOQ</b> 1</p> <p><b>Product type</b> 1U accessory kit</p>	<p>Spare EVAC heat sink</p> <p><b>Note:</b> Only supported in M50CYP2UR204 systems, 1U x4 systems.</p> <p><b>Kit includes:</b>                      (1) – EVAC heat sink</p>
	<p><b>2U GPGPU Air Duct</b></p> <p><b>iPC</b> CYPGPGPUKIT  <b>MM#</b> 99A3RD  <b>UPC</b> 00735858471626  <b>EAN</b> 5032037210065  <b>MOQ</b> 1</p> <p><b>Product type</b> 2U spare FRU</p>	<p>Required 2U accessory kit when installing GPGPU accelerator add-in cards.</p> <p><b>Kit includes:</b>                      (1) – GPGPU air duct                      (1) – GPGPU air duct bracket                      (2) – <b>200/250 mm</b> GPGPU power cable                      (2) – <b>235 mm</b> ATS300W power cable                      (2) – Intel RAID Maintenance Free Backup Unit (RMFBU) bracket</p> <p><b>Notes:</b></p> <ul style="list-style-type: none"> <li>• The Intel Server System M50CYP1UR and M50CYP2UR options do not support GPGPU accelerator cards with active heat sinks.</li> <li>• Systems configured with any type of GPGPU card must have the shipping bracket installed before the system is exposed to any level of shock or vibration or is shipped to the end user location. Failure to install the shipping bracket can cause serious damage to various components within the system.</li> </ul>

Intel® Server M50CYP Family Configuration Guide

Image	Details	Description
	<p><b>Advanced System Management Key</b></p> <p><b>iPC</b> ADVSYSMGMTKEY  <b>MM#</b> 99AJX5  <b>UPC</b> N/A  <b>EAN</b> N/A  <b>MOQ</b> 1</p> <p><b>Product type</b> 1U/2U accessory</p>	<p>Software electronic key to be uploaded to the BMC.</p> <p><b>Note:</b> Needed to enable advance system management features on Integrated BMC Web Console. For more information, see the <i>Intel® Server Board M50CYP2SB Technical Product Specification</i>.</p>

## 7. 1U / 2U Spare and Replacement Parts (FRUs)

System integrators and distributors may choose to hold additional stock of individual system components. Intel makes available the following spare and replacement parts (FRUs) compatible with the specified Intel server family.

**Table 39. Spare and Replacement Parts**

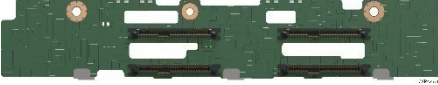

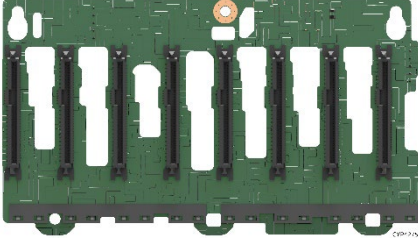
Image	Details	Description
	<p><b>1U 4 x 2.5" Spare Hot Swap Backplane</b></p> <p><b>iPC</b> CYPHSBP1204  <b>MM#</b> 99A3NM  <b>UPC</b> 00735858471800  <b>EAN</b> 5032037210249  <b>MOQ</b> 1</p> <p><b>Product type</b> 1U spare FRU</p>	<p>Hot-swap backplane board spare supporting SAS/SATA and NVMe drives in the M50CYP1UR204 system.</p> <p><b>Kit Includes:</b>  (1) – Backplane board.</p>
	<p><b>1U 12 x 2.5" SAS/SATA/NVMe Hot Swap Backplane</b></p> <p><b>iPC</b> CYPHSBP1212  <b>MM#</b> 99A3NN  <b>UPC</b> 00735858471817  <b>EAN</b> 5032037210256  <b>MOQ</b> 1</p> <p><b>Product type</b> 1U spare FRU</p>	<p>Hot-swap backplane board spare supporting SAS/SATA and NVMe drives in the M50CYP1UR212 system.</p> <p><b>Kit Includes:</b>  (1) – Backplane board.</p>
	<p><b>2U 8 x 2.5" Hot Swap Backplane</b></p> <p><b>iPC</b> CYPHSBP2208  <b>MM#</b> 99A3NF  <b>UPC</b> 00735858471787  <b>EAN</b> 5032037210225  <b>MOQ</b> 1</p> <p><b>Product type</b> 2U spare FRU</p>	<p>Hot-swap backplane board spare supporting SAS/SATA and NVMe drives in the M50CYP2UR208-based systems.</p> <p><b>Kit Includes:</b>  (1) – Backplane board.  (1) – <b>75 mm</b> cable, HSBP I<sup>2</sup>C connector to HSBP I<sup>2</sup>C connector (5 pin to 5 pin)  (1) – <b>250 mm</b> cable, server board I<sup>2</sup>C connector (Left) to HSBP I<sup>2</sup>C connector (Left) (5 pin to 5 pin)  (1) – <b>350 mm</b> cable, server board I<sup>2</sup>C connector (Left) to HSBP (Middle) I<sup>2</sup>C connector (5 pin to 5 pin)</p>

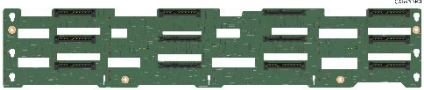
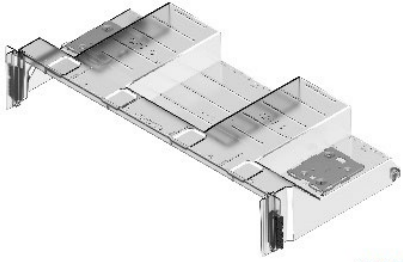
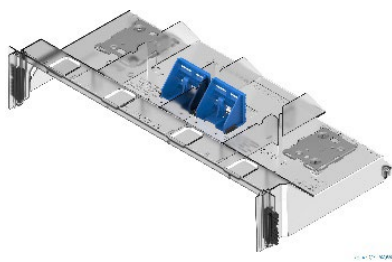

Image	Details	Description
	<p><b>12 x 3.5" SAS/SATA/NVMe Hot Swap Backplane</b></p> <p><b>iPC</b> CYPHSBP2312  <b>MM#</b> 99A3NL  <b>UPC</b> 00735858471794  <b>EAN</b> 5032037210232  <b>MOQ</b> 1</p> <p><b>Product type</b> 2U spare FRU</p>	<p>Combination hot-swap backplane board spare supporting SAS and NVMe drives in the M50CYP2UR312 systems.</p> <p><b>Kit Includes:</b>                      (1) – Backplane board.</p>
	<p><b>2U Tall Air Duct</b></p> <p><b>iPC</b> BRPDUCTSTD  <b>MM#</b> 99A3NW  <b>UPC</b> 00735858471633  <b>EAN</b> 5032037210072  <b>MOQ</b> 1</p> <p><b>Product Type</b> 2U spare FRU</p>	<p>Air duct for 2U-Tall heat sink</p> <p><b>Kit Includes:</b>                      (1) – Air duct with holders for add-in cards.                      (2) – Intel RAID Maintenance Free Backup Unit (RMFBU) bracket installed on top of air duct.</p>
	<p><b>1U Tall Air Duct</b></p> <p><b>iPC</b> BRPDUCTSWFHFL  <b>MM#</b> 99A3RP  <b>UPC</b> 00735858471640  <b>EAN</b> 5032037210089  <b>MOQ</b> 1</p> <p><b>Product type</b> 2U spare FRU</p>	<p>Air duct for 1U-Tall heat sink</p> <p><b>Kit Includes:</b>                      (1) – Air duct with holders for full length add-in cards.                      (2) – Intel RAID Maintenance Free Backup Unit (RMFBU) bracket installed on top of air duct.</p>
	<p><b>1U System Fan</b></p> <p><b>iPC</b> CYPFAN1UKIT  <b>MM#</b> 99A3NZ  <b>UPC</b> 00735858471848  <b>EAN</b> 5032037210287  <b>MOQ</b> 4</p> <p><b>Product type</b> 1U spare FRU</p>	<p>Spare system fans</p> <p><b>Each Kit Includes:</b>                      (1) – 40 x 40 x 38 mm dual motor system fans with 8-pin connectors.</p>

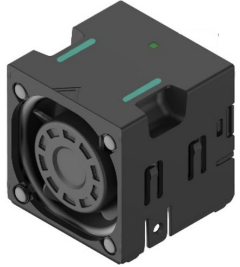


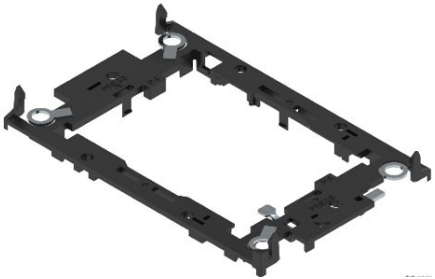




Image	Details	Description
	<p><b>2U Fan</b></p> <p><b>iPC</b> CYPFAN2UKIT  <b>MM#</b> 99A3P0  <b>UPC</b> 00735858471855  <b>EAN</b> 5032037210294  <b>MOQ</b> 3</p> <p><b>Product type</b> 2U spare FRU</p>	<p><b>Each Kit Includes:</b>            (1) – 60 x 60 x 38 mm dual motor system fans with 6-pin connectors.</p>
	<p><b>2.5" SSD Drive Mounting Rail Plus Drive Extraction Lever Kit</b></p> <p><b>iPC</b> CYP25HSCARRIER  <b>MM#</b> 99AKCJ  <b>UPC</b> 00735858471596  <b>EAN</b> 5032037210034  <b>MOQ</b> 1</p> <p><b>Product type</b> 1U/2U spare FRU</p>	<p>Spare 2.5" SSD Drive Mounting Rail Plus Drive</p> <p><b>Each Kit Includes:</b>            (8) –2.5" SSD drive mounting rails plus drive extraction lever            (8) –2.5" SSD drive blank</p>
	<p><b>3.5" Tool Less Hot Swap Drive Carrier</b></p> <p><b>iPC</b> FXX35HSCAR2  <b>MM#</b> 958245  <b>UPC</b> 00735858345675  <b>EAN</b> 5032037106160  <b>MOQ</b> 1</p> <p><b>Product type</b> 1U/2U spare FRU</p>	<p>Spare 3.5" tool less drive hot swap drive carrier</p> <p><b>Includes:</b>            (1) – 3.5" tool less drive hot swap drive carrier with mounting screws for mounting 2.5" SSDs.</p>

Image	Details	Description
	<p><b>Processor Carrier Clip</b></p> <p><b>iPC</b> ICXPHMMOQ2  <b>MM#</b> 99A3PL  <b>UPC</b> 00735858475273  <b>EAN</b> 5032037213226  <b>MOQ</b> 2</p> <p><b>Product type</b> 1U/2U spare FRU</p>	<p>Spare processor carrier clip</p> <p><b>Kit Includes:</b>                      (2) – processor carrier clip</p>
	<p><b>Trusted Platform Module (TPM) 2.0</b></p> <p><b>iPC</b> AXXTPMENC9  <b>MM#</b> 99C8ZW  <b>UPC</b> 00735858527378  <b>EAN</b> 5032037259385  <b>MOQ</b> 1</p> <p><b>Product type</b> 1U/2U accessory kit</p>	<p>A TPM is a hardware-based security device that addresses the growing concern on boot process integrity and offers better data protection. TPM protects the system start-up process by ensuring that it is tamper-free before releasing system control to the operating system. A TPM device provides secured storage to store data, such as security keys and passwords. In addition, a TPM device has encryption and hash functions.</p> <p>AXXTPMENC9 implements TPM as per TPM PC Client specifications revision 2.0 by the Trusted Computing Group (TCG)</p>
	<p>Trusted Platform Module (TPM) 2.0</p> <p><b>iPC</b> AXXTPMENC9  <b>MM#</b> 99C69H  <b>UPC</b> 00735858527378  <b>EAN</b> 5032037259385  <b>MOQ</b> 1</p> <p><b>Product type</b> 1U/2U accessory kit</p>	<p>A TPM is a hardware-based security device that addresses the growing concern on boot process integrity and offers better data protection. TPM protects the system start-up process by ensuring that it is tamper-free before releasing system control to the operating system. A TPM device provides secured storage to store data, such as security keys and passwords. In addition, a TPM device has encryption and hash functions.</p> <p>AXXTPMENC9 implements TPM as per TPM PC Client specifications revision 2.0 by the Trusted Computing Group (TCG)</p> <p>This part is no longer available to order; please refer to replacement part MM# 99C8ZW. AXXTPMENC9 has improvements in provisioning support.</p>

## Intel® Server M50CYP Family Configuration Guide

Image	Details	Description
	<p>Intel® Trusted Platform Module (TPM) 2.0</p> <p>iPC            AXXTPMENC8  MM#            955867  UPC            00735858345712  EAN            5032037106207  MOQ            1</p> <p>Product type    1U/2U Accessory kit  Status:            Discontinued</p>	<p>A TPM is a hardware-based security device that addresses the growing concern on boot process integrity and offers better data protection. TPM protects the system start-up process by ensuring it is tamper-free before releasing system control to the operating system. A TPM device provides secured storage to store data, such as security keys and passwords. In addition, a TPM device has encryption and hash functions.</p> <p>AXXTPMENC8 implements TPM as per TPM PC Client specifications revision 2.0 by the Trusted Computing Group (TCG)</p> <p>This part is no longer available to order; please refer to replacement part MM# 99C8ZW. AXXTPMENC9 has improvements in provisioning support.</p>
	<p><b>Intel® Trusted Platform Module (TPM) 2.0</b></p> <p><b>iPC</b>            AXXTPMCHNE8  <b>MM#</b>            960608  <b>UPC</b>            00735858347341  <b>EAN</b>            5032037107068  <b>MOQ</b>            1</p> <p><b>Product type</b>    Accessory kit</p>	<hr/> <p><b>Note:</b> AXXTPMCHNE8 compatible for use in China.</p> <hr/> <p>A TPM is a hardware-based security device that addresses the growing concern on boot process integrity and offers better data protection. TPM protects the system start-up process by ensuring it is tamper-free before releasing system control to the operating system. A TPM device provides secured storage to store data, such as security keys and passwords. In addition, a TPM device has encryption and hash functions.</p> <p>AXXTPMCHNE8 implements TPM as per TPM PC Client specifications revision 2.0 by the Trusted Computing Group (TCG)</p>

## Appendix A. Glossary

Term	Definition
<b>BIK</b>	Baseboard In Knock-Down-Kit – Integrated System
<b>BOM</b>	Bill of Materials
<b>CMA</b>	Cable Management Arm
<b>CRPS</b>	Common Redundant Power Supply
<b>DDDC</b>	Double Device Data Correction
<b>EAN</b>	International Article Number (Barcode)
<b>ECC</b>	Error Correcting Code
<b>EMI</b>	Electromagnetic Interference
<b>FRU</b>	Field Replaceable Unit
<b>GPGPU</b>	General Purpose computing on Graphics Processing Unit
<b>iPC</b>	Intel Product Code
<b>iPN</b>	Intel Product Number
<b>JBOD</b>	Just a bunch of drives
<b>L6 BIK</b>	Integrated system with no processors, memory, or storage devices installed
<b>L9 BIK</b>	Integrated system including storage devices, but no processors or memory
<b>KDK</b>	Knock-Down-Kit – (Chassis only product)
<b>KVM</b>	Keyboard, Video, Mouse
<b>MM#</b>	Main Material order number
<b>MOQ</b>	Minimum Order Quantity
<b>NDA</b>	Non-disclosure agreement
<b>NVMe*</b>	NVM Express* – based on Non-Volatile Memory Host Controller Interface Specification (NVMHCI)
<b>ODD</b>	Optical disk drive
<b>Intel® OP HFI</b>	Intel® Omni-Path Host Fabric Interface
<b>Optional Accessory</b>	Hardware that can be added to the system to enhance the default feature set of the shipping configuration
<b>PCBA</b>	Printed Circuit Board Assembly
<b>QSFP</b>	Quad Small Form Factor Pluggable
<b>RAID</b>	Redundant Array of Independent Drives
<b>Required Option</b>	Hardware that must be added to the shipping configuration for the system to operate
<b>RMFBU</b>	RAID Maintenance Free Backup Unit
<b>ROC</b>	RAID on Chip
<b>RA</b>	Right Angle cable connector position

## Intel® Server M50CYP Family Configuration Guide

Term	Definition
<b>RRA</b>	Reverse Right Angle cable connector position
<b>SAS</b>	Serial Attached SCSI
<b>SATA</b>	Serial ATA
<b>SFF NVMe*</b>	NVMe SSD in a 2.5" form factor
<b>SFF</b>	Small Form Factor
<b>SFP</b>	Small Form Factor Pluggable
<b>SKU</b>	Stock Keeping Unit
<b>SSD</b>	Solid State Drive
<b>TPM</b>	Trusted Platform Manager
<b>UPC</b>	Universal Product Code (Barcode)
<b>VT</b>	Vertical connector position (also known as horizontal, straight)
<b>Intel® VCA</b>	Intel® Visual Compute Accelerator
<b>Intel® VROC</b>	Intel® Virtual RAID on CPU
<b>PCH</b>	Platform Controller Hub
<b>PCN</b>	Product Change Notification