



Questo manuale d'istruzione è fornito da trovaprezzi.it. Scopri tutte le offerte per [JBL Spinner BT](#) o cerca il tuo prodotto tra le [migliori offerte di Personal Audio e Hi-Fi](#)



Questo manuale d'istruzione è fornito da trovaprezzi.it. Scopri tutte le offerte per [JBL Spinner BT](#) o cerca il tuo prodotto tra le [migliori offerte di Personal Audio e Hi-Fi](#)



SPINNERBT

QUICK START GUIDE



WHAT'S IN THE BOX

1. Platter Matt
2. Platter
3. Headshell and Cartridge
4. 2x Dust Cover Hinges
5. Single Adaptor
6. Counterweight
7. Interconnect
8. Belt (fitted to platter)
9. Power Supply*

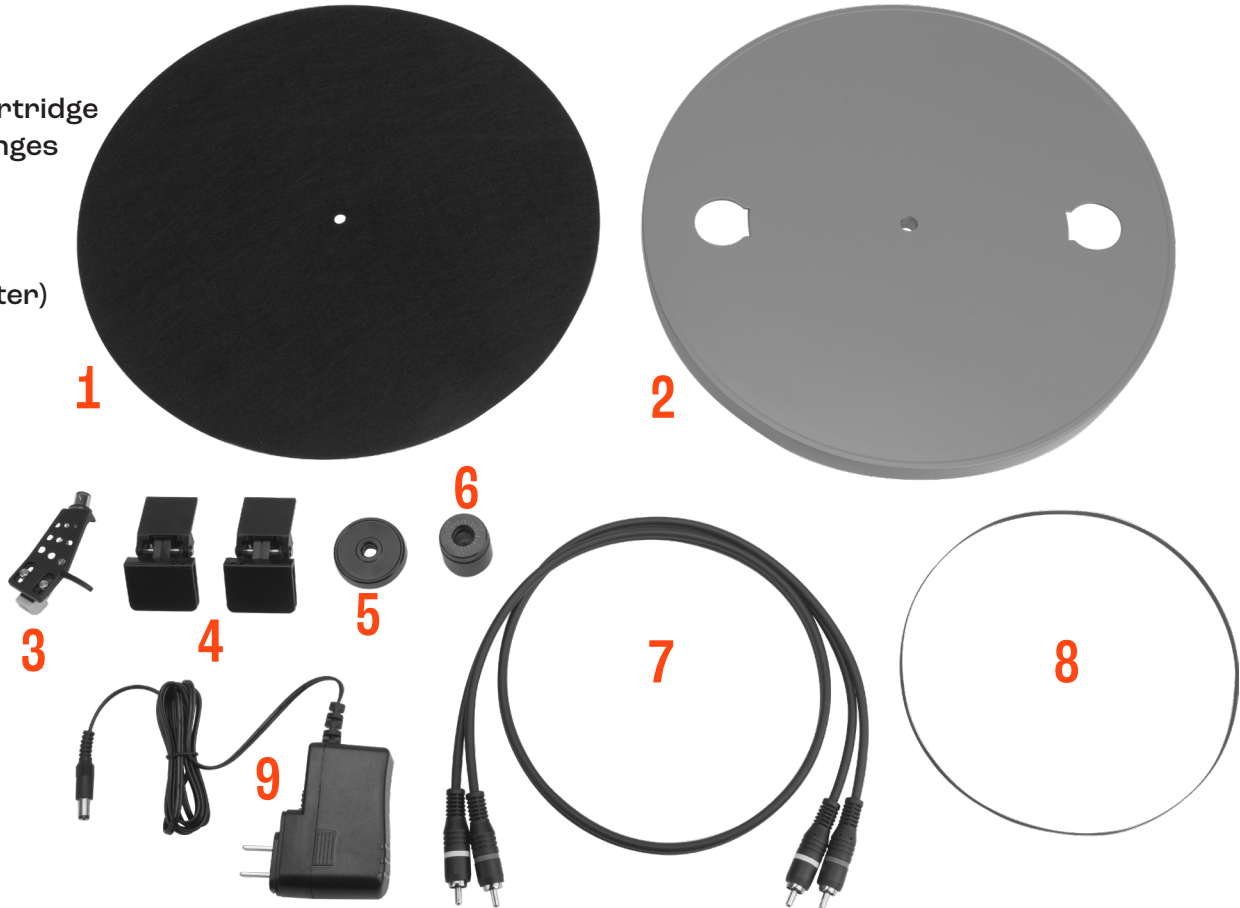

*POWER CORD PLUG TYPE VARY BY REGION

ASSEMBLY

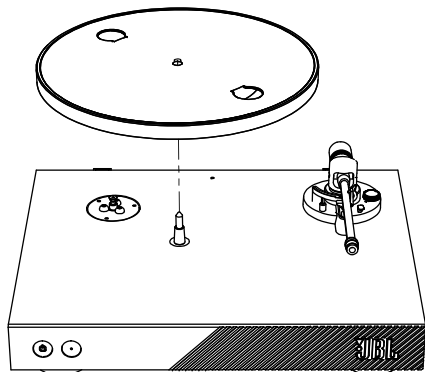

1. Fit the platter

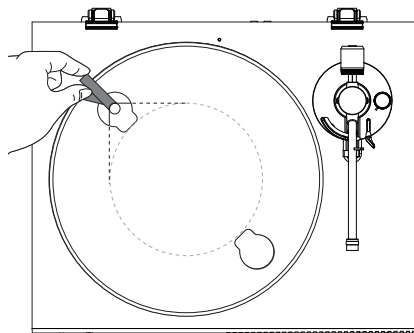

2. Fit the belt around the motor pulley

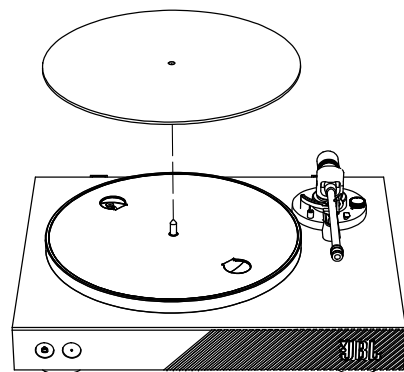

3. Fit the platter mat

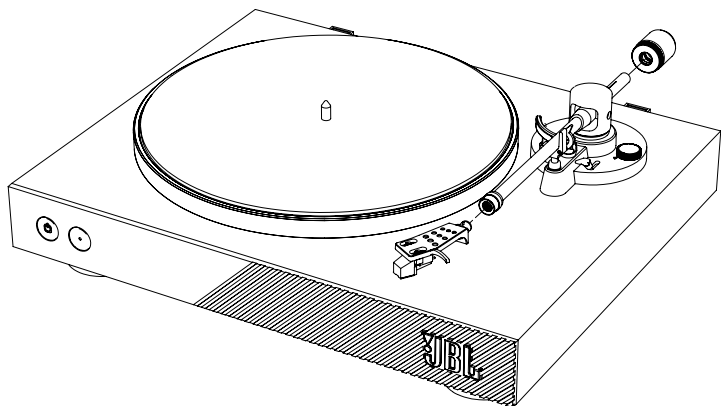

4. Fit the Headshell

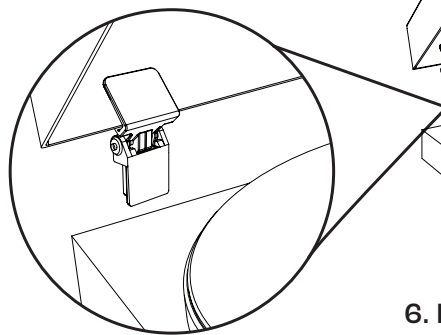

5. Fit the Counterweight

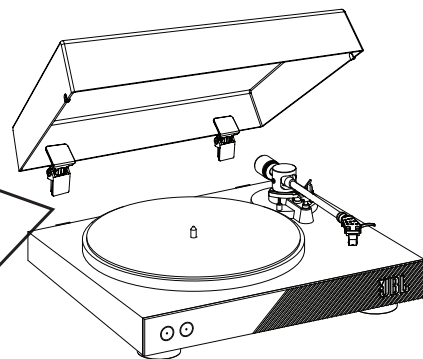

6. Fit the dust cover

BALANCE THE TONEARM

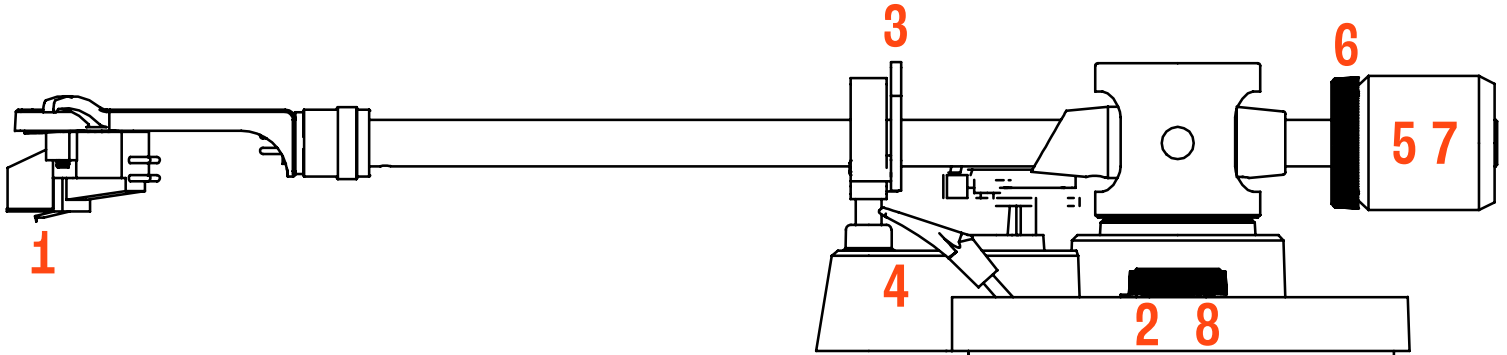

One step at a time...

1. Remove stylus cover - be careful around the needle!
2. Ensure Anti-Skate is set to 0
3. Unclip the tonearm from the rest
4. Ensure the arm lift is in the down position
5. Rotate the counterweight until the arm floats (it should not go keep going up or down)
6. Set the counterweight dial to 0 at the top (careful not to move the counterweight)
7. With the dial at 0, rotate the counterweight 1 full turn anti-clockwise (so the counterweight moves toward the cartridge)
8. Set the Anti-skate dial to 3.

ON THE REAR

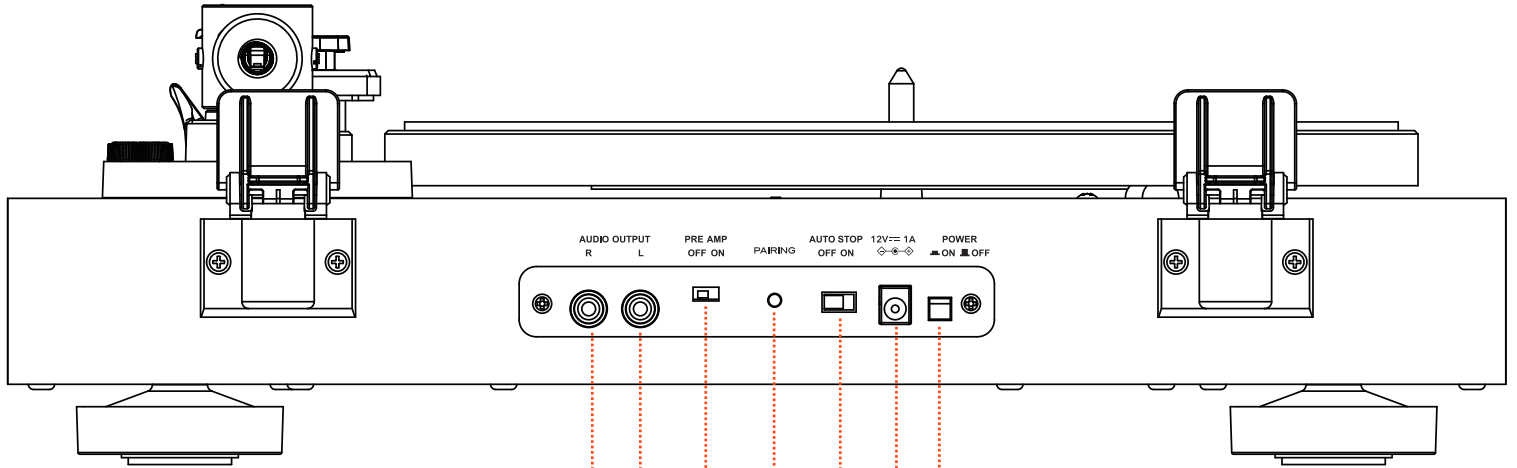

1. Analog Outputs
2. Pre-amp Off/On
(turn off when connected to an amplifier's Phono input)
3. Bluetooth Button
4. Auto Start/Stop
(Enables the automatic start and stop of the platter)
5. Power Inlet
6. Power Switch

BLUETOOTH PAIRING

Wireless Specification:

Bluetooth profile Version: A2DP 1.4, AVRCP 1.6.2

Bluetooth transmitter frequency range: 2.4~2.4835 GHz

Bluetooth Max. transmitting power: < 2.0 dBm (EIRP)

Bluetooth transmitter modulation: GFSK, $\pi/4$ -DQPSK, 8DPSK

Bluetooth Version: 5.3

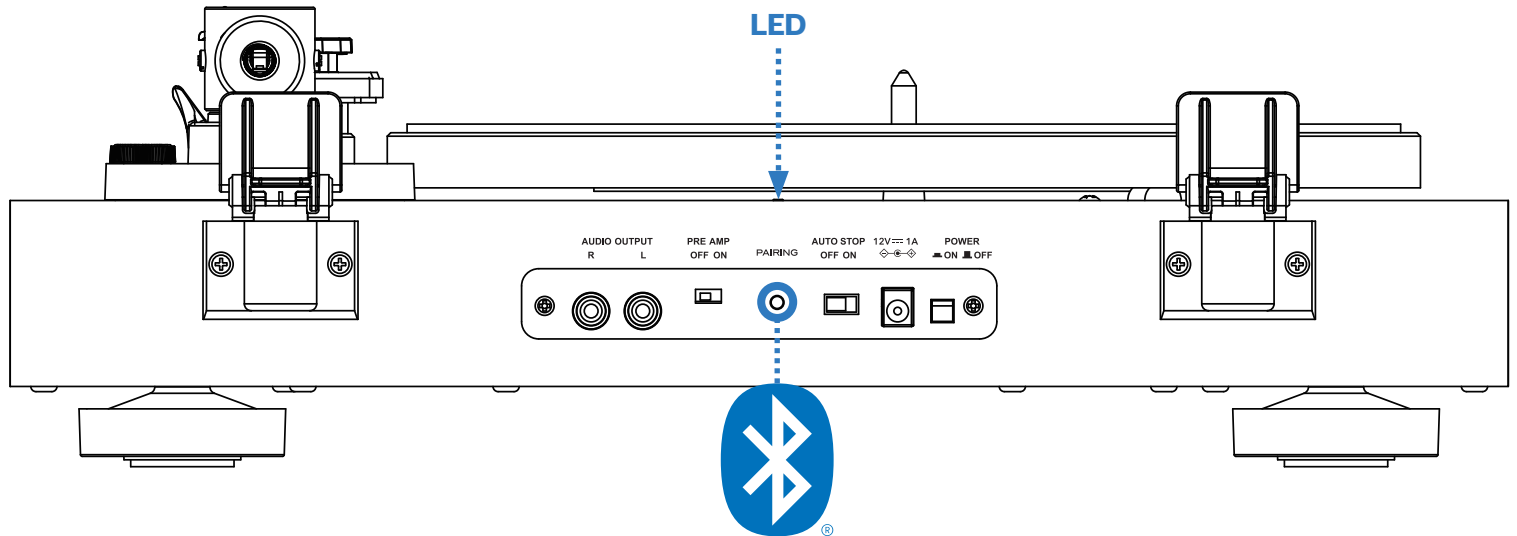

Pairing Mode = Press and hold button for 2 seconds + Blue LED Flashing

Connected = Blue LED Solid

Reconnect = Tap button (Blue LED flashing = Connecting)

Clear pairing record = Press and hold for 10 seconds

PLAYING RECORDS

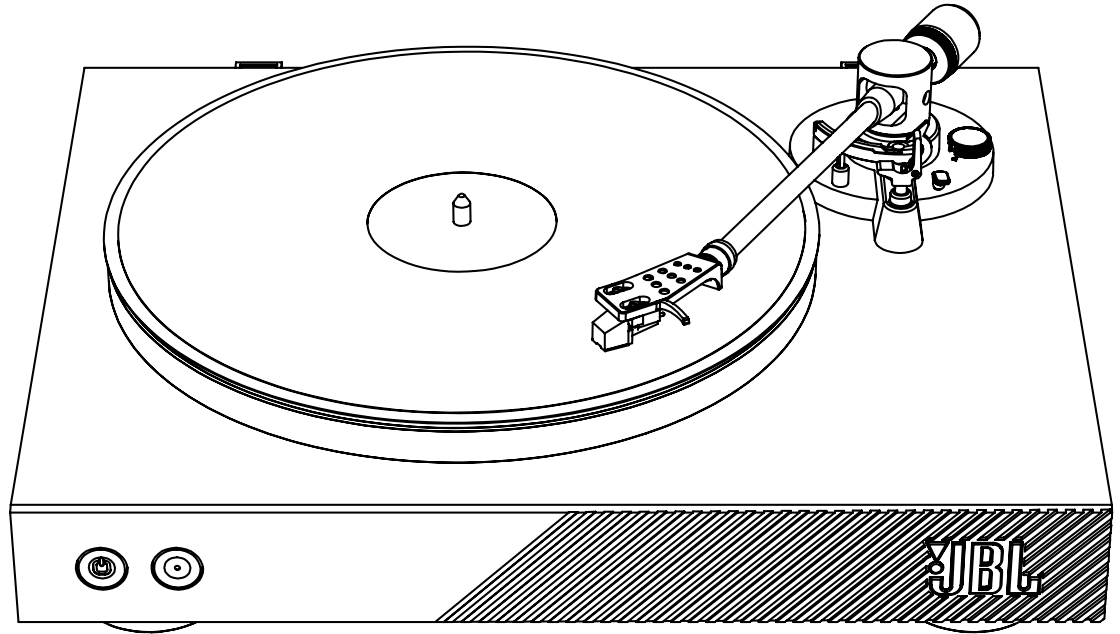

One step at a time...

1. Remove stylus cover
2. Place your record on the platter (it is best to avoid touching the playing surface)
3. Unclip the tonearm from the rest
4. Raise the arm lift lever
5. Move the tonearm so the cartridge is over the start of the record
6. Start the platter to 33 or 45 as required for the record you are playing
7. Lower the arm lift lever - the arm will gently lower to the record



FR

Cet appareil,
ses accessoires
et cordons
se recyclent

À DÉPOSER
EN MAGASIN



OU

À DÉPOSER
EN DÉCHÈTERIE



Points de collecte sur www.quefairedemesdechets.fr



快速入门指南



SPINNERBT



产品清单

1. 唱盘垫
2. 唱盘
3. 唱头壳和唱头
4. 2 x 防尘罩铰链
5. 电源适配器
6. 配重
7. 连接线缆
8. 皮带 (匹配安装在唱盘上)
9. 电源*

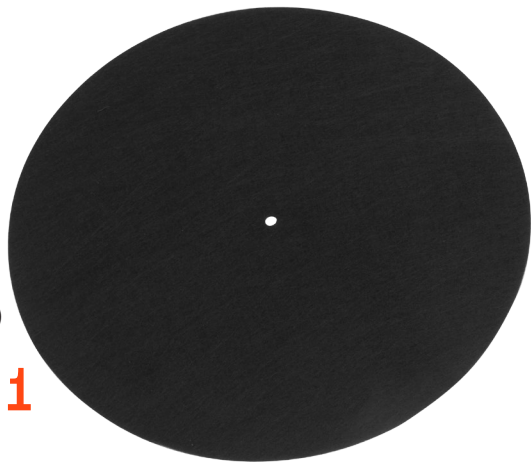

1

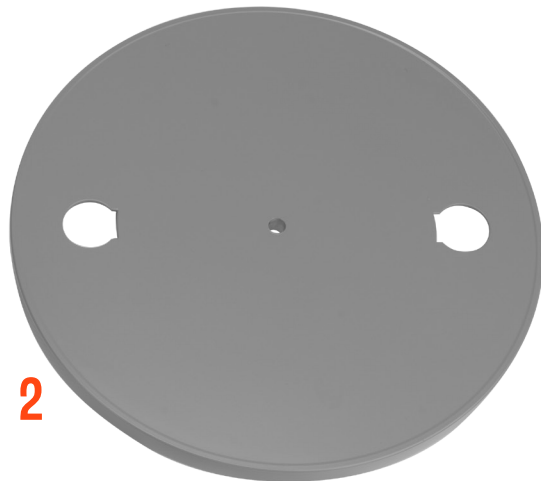

2



3



4



5



6



7

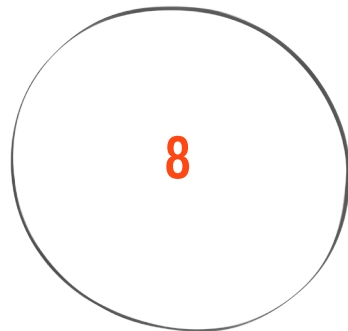

8

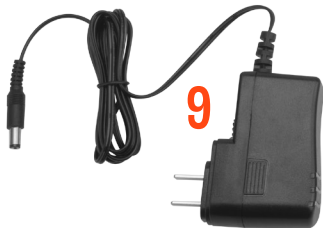

9

*电源线插头类型因地区而异。

组装

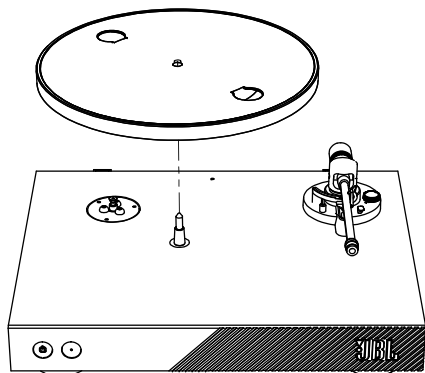

1. 安装唱盘

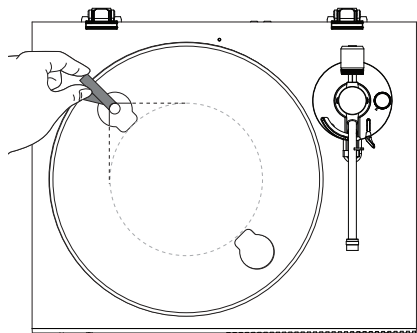

2. 将皮带安装在电机皮带轮上

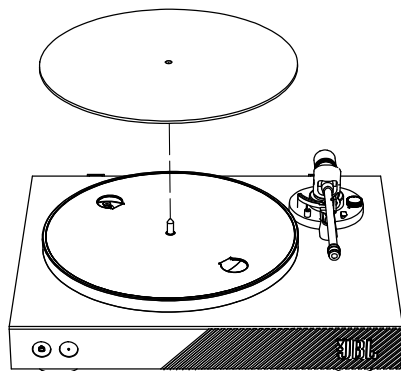

3. 安装唱盘垫

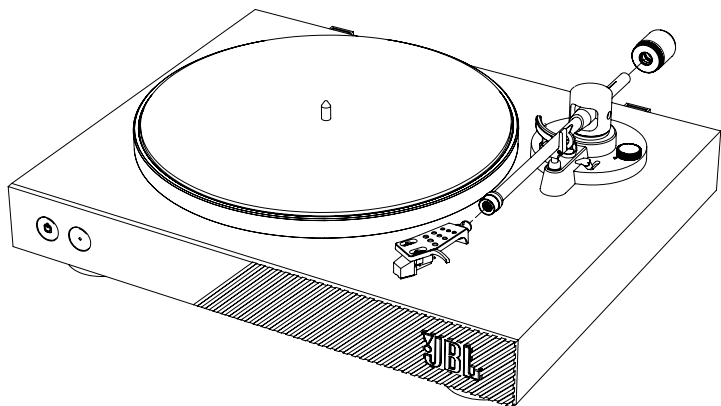

4. 安装唱头壳

5. 安装配重

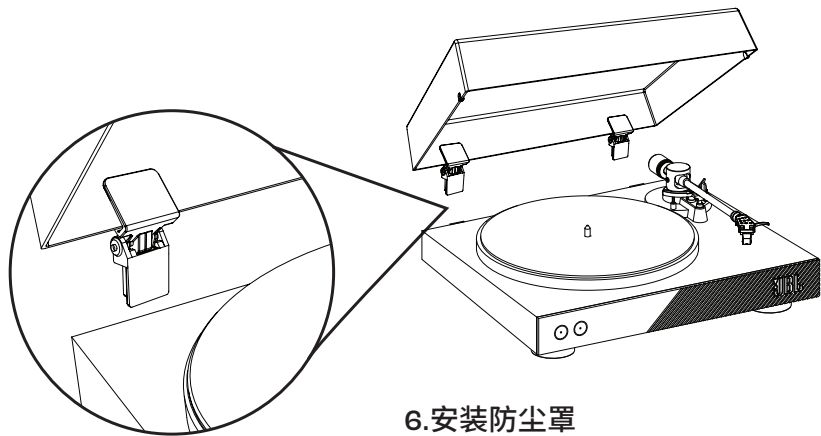

6. 安装防尘罩

调节唱臂平衡

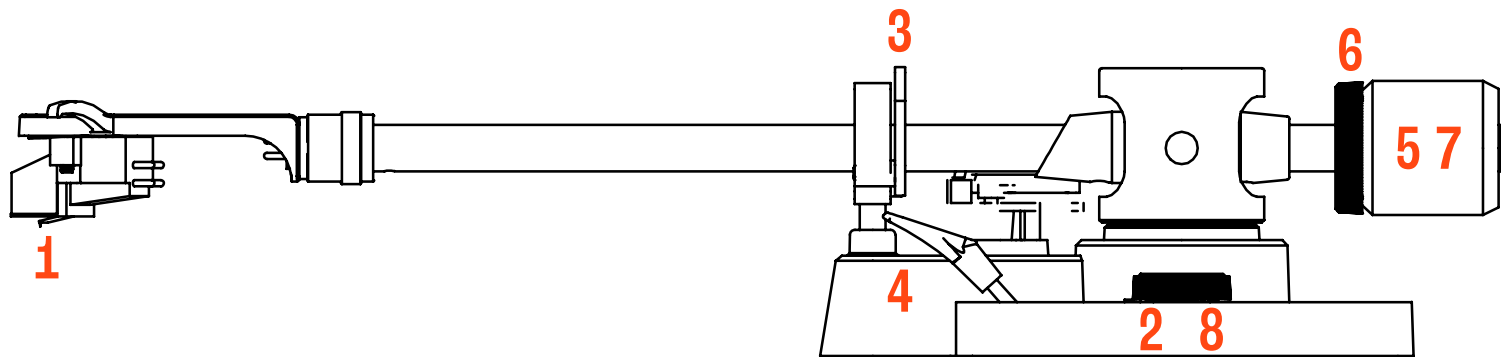

逐步操作……

1. 取下唱针保护罩——小心针头！
2. 确保将防滑板设置为 0
3. 从其余部分解开唱臂
4. 确保抬臂放在下面
5. 旋转配重直到唱臂浮动（它不应继续上下移动）
6. 将配重刻度盘顶部设置为 0（注意不要移动配重）
7. 将刻度盘设置为 0 后，逆时针旋转配重 1 整圈（使配重靠近唱头）
8. 将防滑板刻度盘设置为 3。

后部

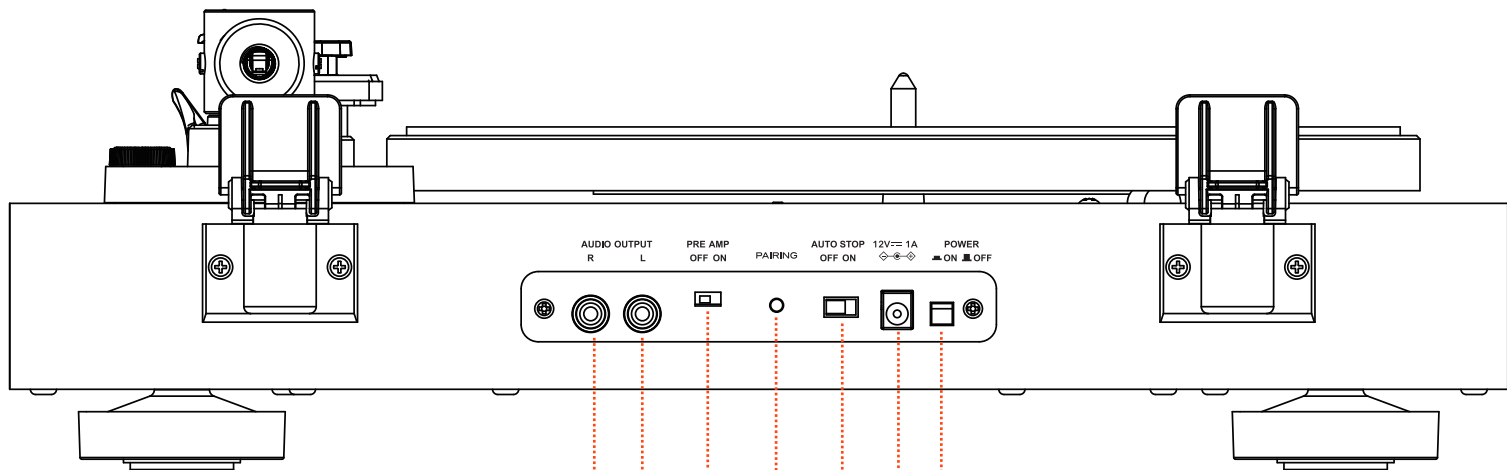

1. 模拟输出
2. 前置功放关闭/打开
(与功放的 Phono 输入连接时, 关闭)
3. 蓝牙按钮
4. 自动启动/停止
(启用唱盘上的自动启动和停止功能)
5. 电源插口
6. 电源开关

蓝牙配对

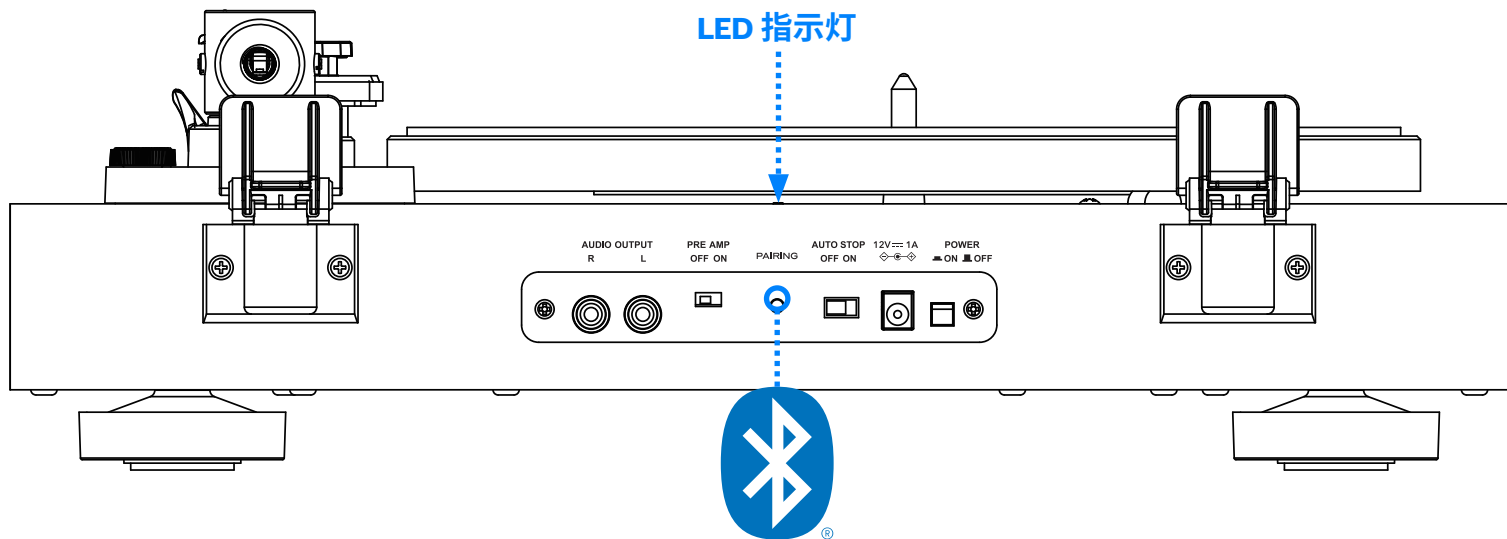

配对模式 = 长按 2 秒钟 + LED 指示灯闪烁蓝光

已连接 = LED 指示灯呈蓝色常亮

重新连接 = 点击按钮 (LED 指示灯闪烁蓝光 = 正在连接)

清除配对记录 = 长按 10 秒

播放唱片

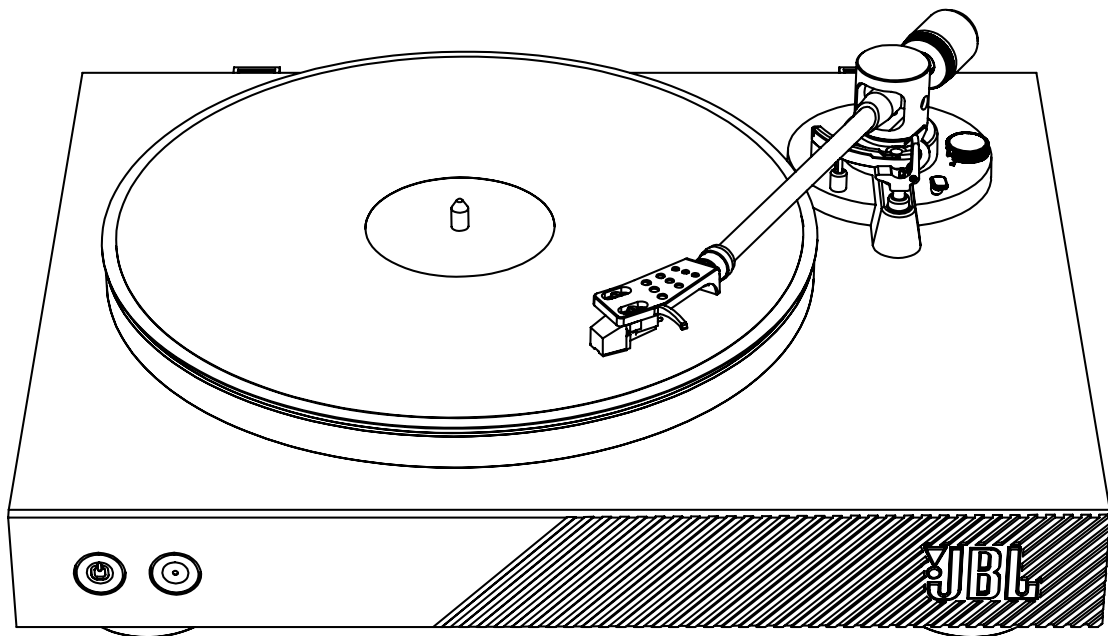

逐步操作……

1. 取下唱针保护罩
2. 将唱片放在唱盘上(最好避免接触唱片的播放表面)
3. 从其余部分解开唱臂
4. 抬起唱臂升降杆
5. 移动唱臂,使唱头位于唱片起始位置
6. 根据你正在播放的唱片要求,将唱盘速度调到 33 或 45
7. 放低唱臂升降杆——唱臂将缓慢降低到唱片上



FR

Cet appareil,
ses accessoires
et cordons
se recyclent

À DÉPOSER
EN MAGASIN



À DÉPOSER
EN DÉCHÈTERIE



OU

Points de collecte sur www.quefairedemesdechets.fr

CE UK
CA

快速入門指南



SPINNERBT



包裝盒內物品

1. 唱片墊
2. 轉盤
3. 唱頭蓋
4. 2x防塵套鉸鏈
5. 單個變壓器
6. 針壓配重環
7. 訊號線
8. 皮帶（與唱片墊適配）
9. 電源供應器*

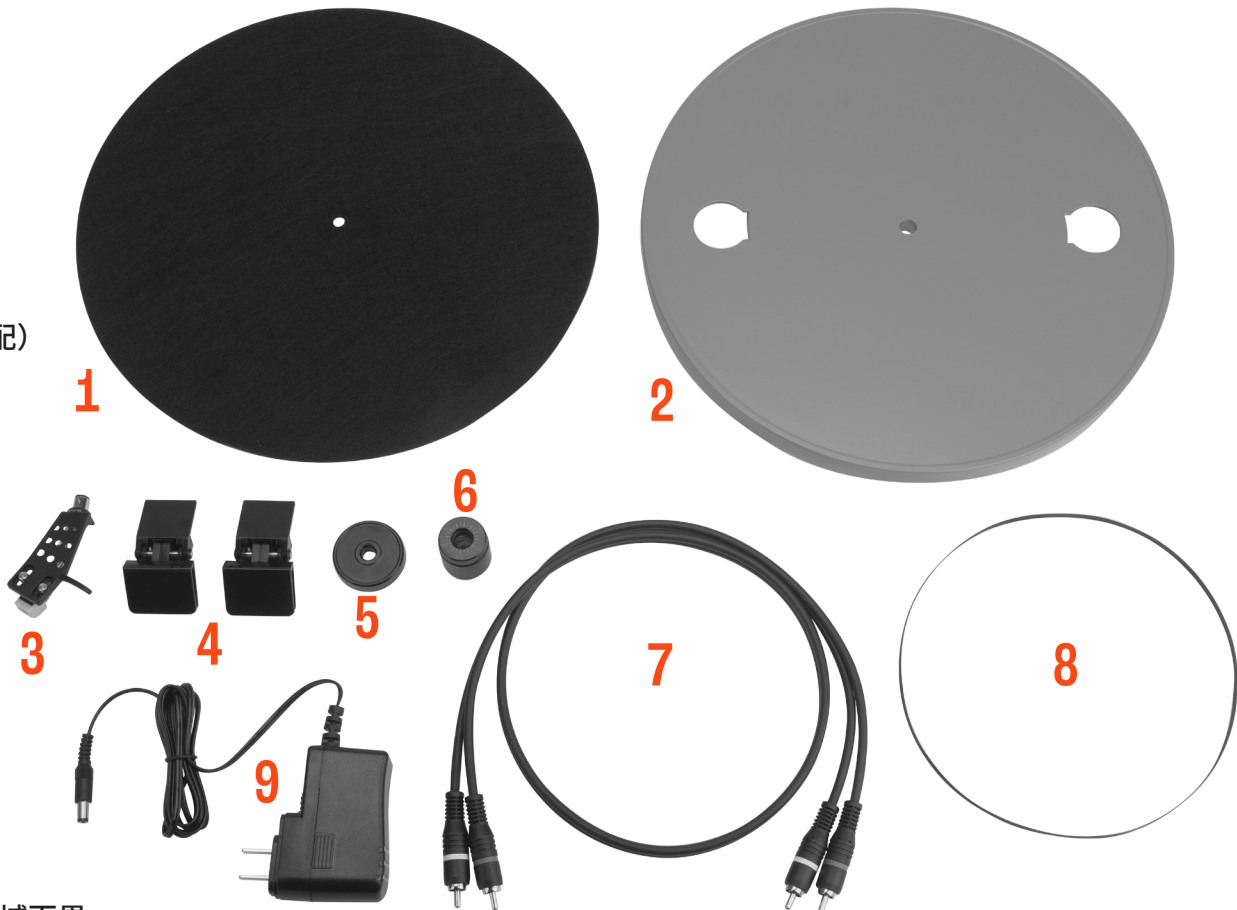

*電源線插頭類型因區域而異

組裝

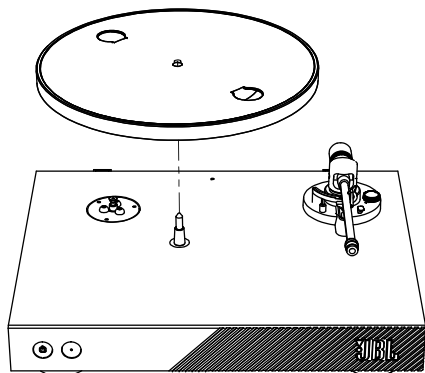

1. 安裝轉盤

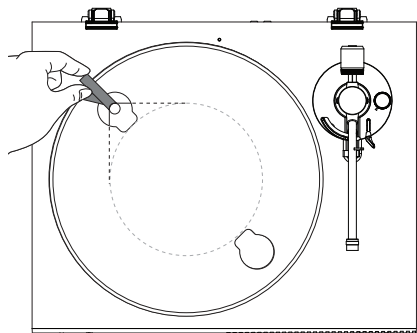

2. 在電動皮帶輪環繞皮帶

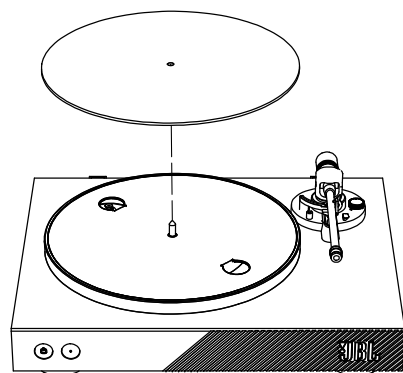

3. 安裝唱片墊

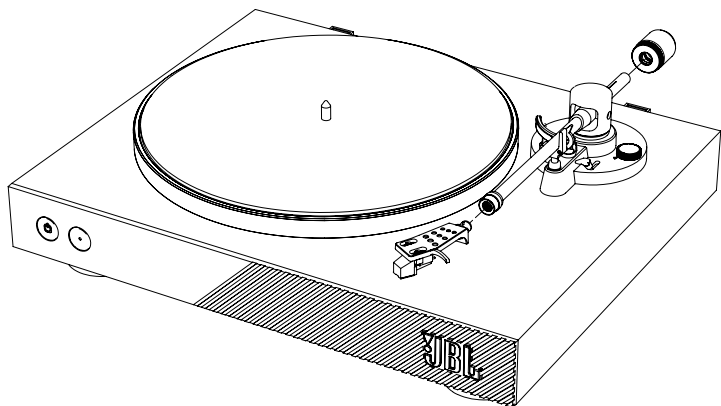

4. 安裝唱頭蓋

5. 安裝針壓配重環

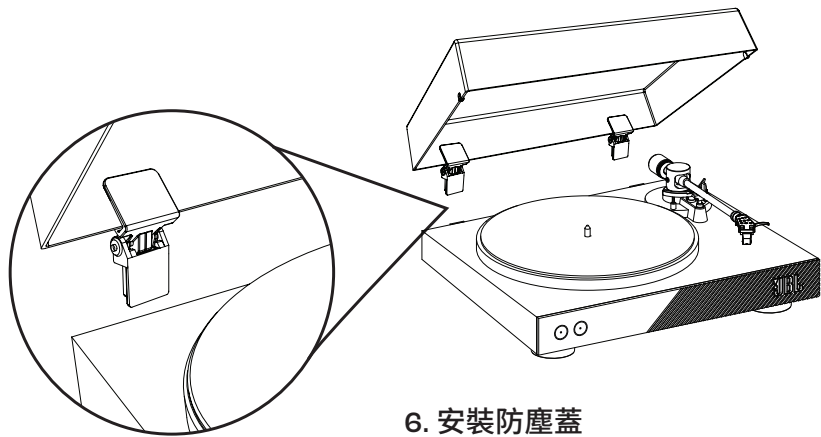

6. 安裝防塵蓋

平衡唱臂

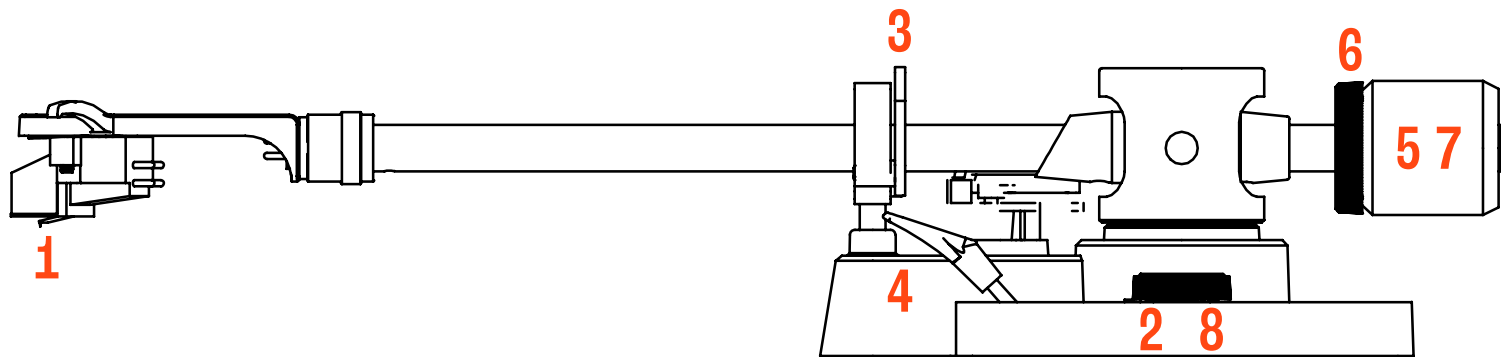

每次完成一個步驟……

1. 移除唱針護蓋——注意針頭!
2. 確保唱臂防滑調節為 0
3. 鬆開唱臂
4. 確保唱臂起臂器處於下方
5. 旋轉針壓配重環，直至唱臂浮起（正常情況下不會一直上浮或下沉）
6. 在頂部調節針壓配重環轉盤至 0（注意勿移動針壓配重環）
7. 轉盤處於 0 時，逆時針旋轉針壓配重環 1 整圈（針壓配重環向唱頭蓋方向移動）
8. 把防滑轉盤調節至 3

在背面

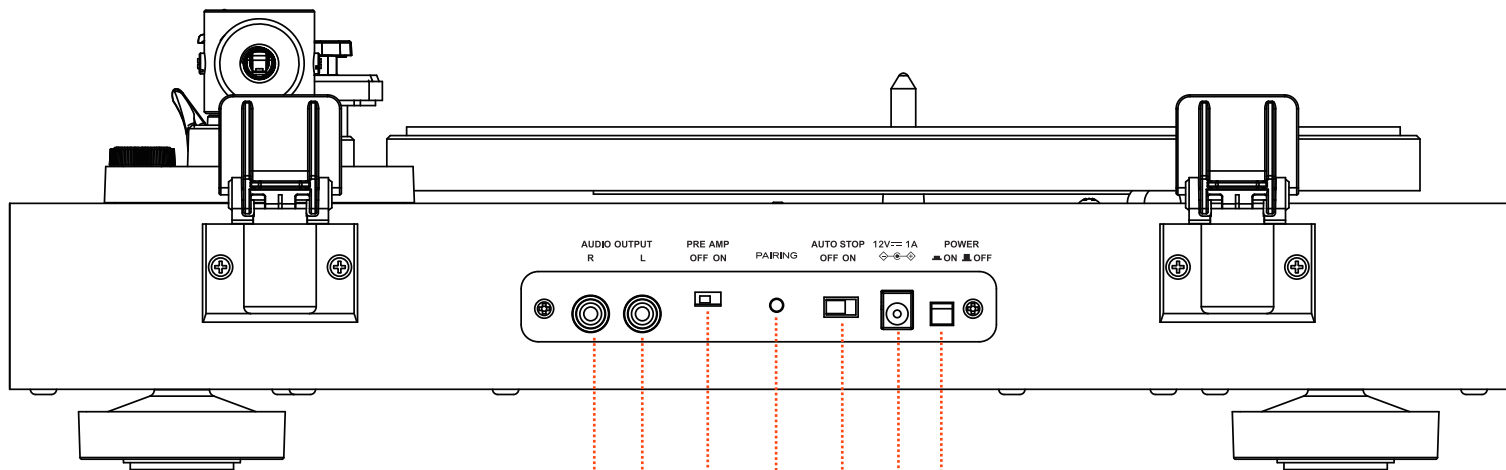

1. 類比輸出
2. 擴大開關
(在連接放大機的唱頭輸入時關閉)
3. 藍牙按鈕
4. 自動啟動/停止
(啟用自動啟動和停止轉盤)
5. 電源插座
6. 電源開關

藍牙配對

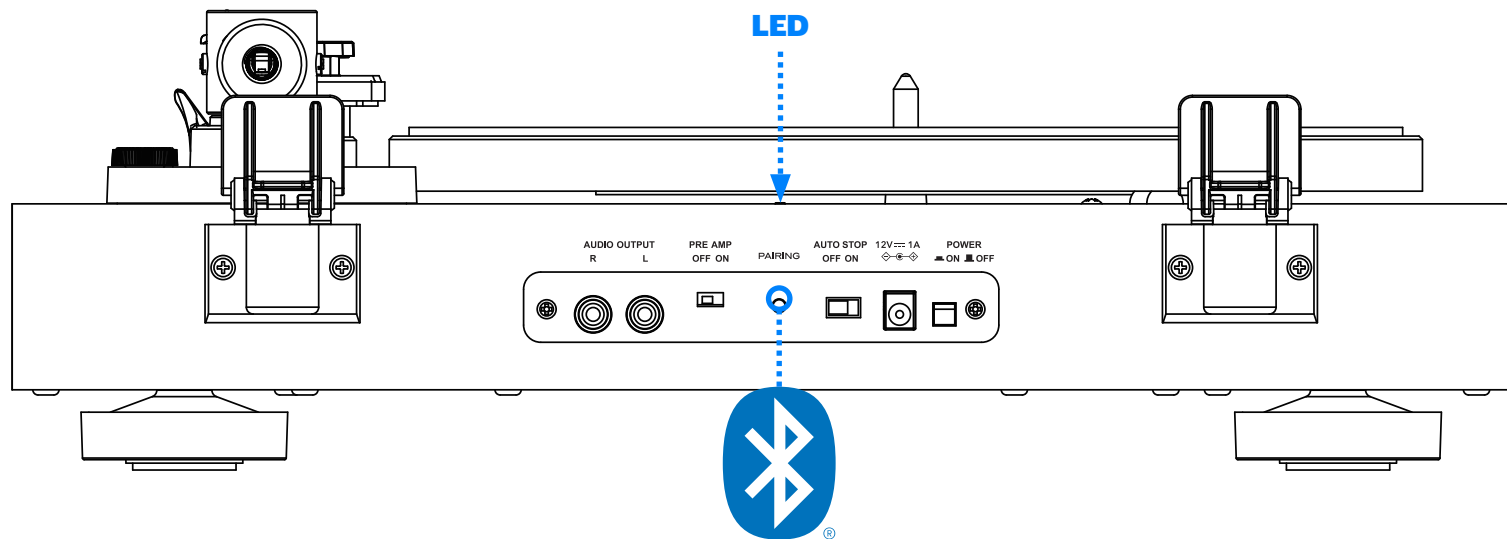

配對模式 = 長按按鈕 2 秒 + 藍色 LED 閃爍

成功連接 = 藍色 LED 常亮

重新連接 = 按一下按鈕 (藍色 LED 閃爍 = 連接中)

清除配對記錄 = 長按 10 秒

播放唱片

低功率射頻器材技術規範章節 3.8.2

取得審驗證明之低功率射頻器材，非經核准，公司、商號或使用者均不得擅自變更頻率、加大功率或變更原設計之特性及功能。低功率射頻器材之使用不得影響飛航安全及干擾合法通信；經發現有干擾現象時，應立即停用，並改善至無干擾時方得繼續使用。前述合法通信，指依電信管理法規定作業之無線電通信。低功率射頻器材須忍受合法通信或工業、科學及醫用電波輻射性電機設備之干擾。

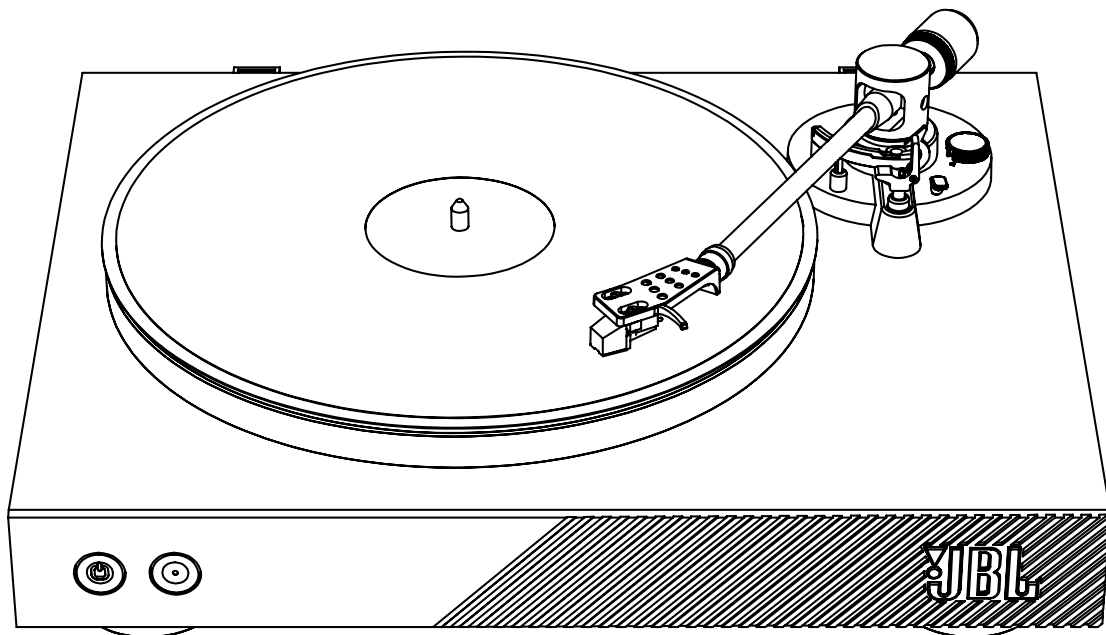

每次完成一個步驟……

1. 移除唱針護蓋
2. 把您的唱片放在轉盤 (避免接觸播放面尤佳)
3. 鬆開唱臂
4. 上升唱臂桿
5. 移動唱臂，讓唱頭蓋處於唱片開始的上方位置
6. 根據您正在播放的唱片，把轉盤調節至 33 轉或 45 轉
7. 降下唱臂桿——唱臂將緩慢放下到唱片



Points de collecte sur www.quefairemesdechets.fr



빠른 시작 가이드



SPINNERBT

구성품

1. 플래터 매트
2. 플래터
3. 헤드샐 및 카트리지
4. 더스트 커버 힌지 x2개
5. 단일 어댑터
6. 카운터웨이트
7. 인터커넥트
8. 벨트(플래터에 핏팅)
9. 전원 공급 장치*



*전원 코드 플러그 유형은 지역별로 다릅니다

조립

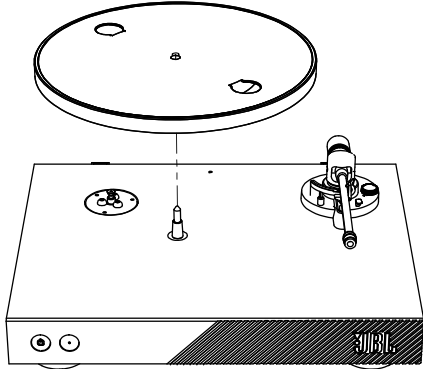

1. 플래터를 장착합니다

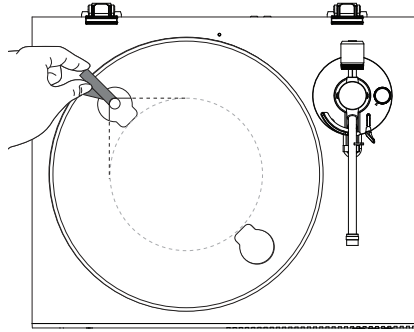

2. 모터 풀리 주위에 벨트를
장착합니다

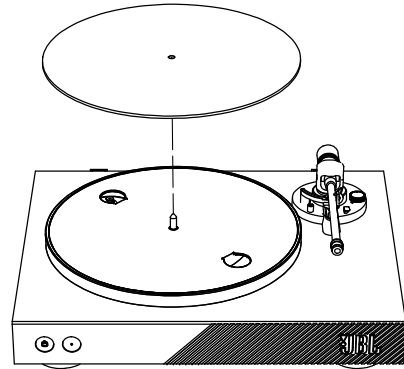

3. 플래터 매트를 장착합니다

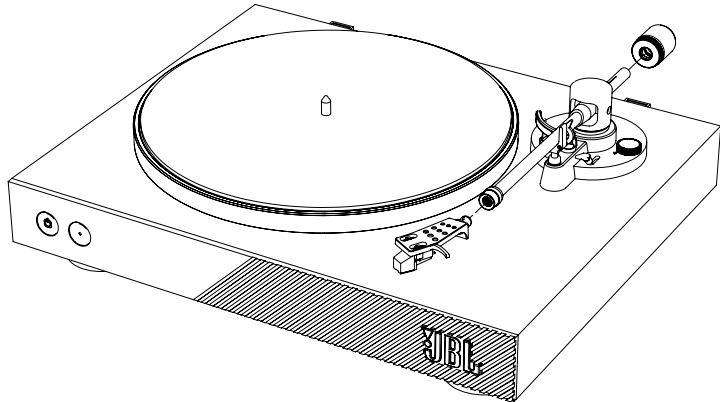

4. 헤드셸을 장착합니다

5. 카운터웨이트를 장착합니다

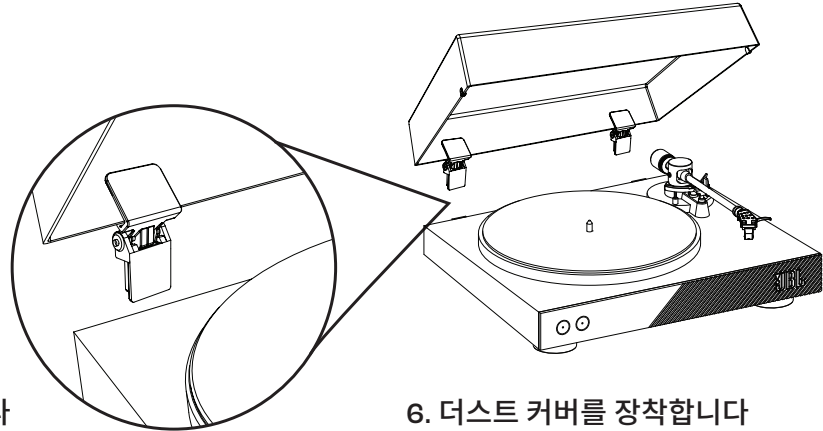

6. 더스트 커버를 장착합니다

톤암 균형 맞추기

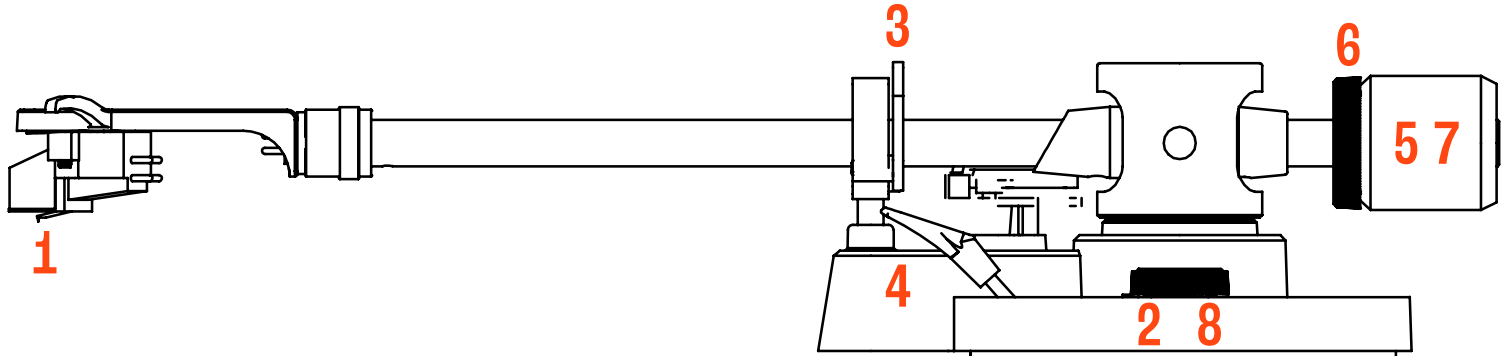

한 단계씩 수행하십시오.

1. 스타일러스 커버 제거 - 바늘 주위를 조심하십시오!
2. 안티 스케이트가 0으로 설정되어 있는지 확인합니다
3. 나머지 부분에서 톤암을 분리합니다
4. 암 리프트가 아래에 있는지 확인합니다
5. 암이 올라올 때까지 카운터웨이트를 돌립니다(계속 위아래로 움직이지 않아야 함)
6. 상단의 카운터웨이트 다이얼을 0으로 설정합니다(카운터웨이트가 움직이지 않도록 주의)
7. 다이얼을 0에 두고 카운터웨이트를 시계 반대 방향으로 완전히 한 바퀴 돌립니다(카운터웨이트가 카트리지 쪽으로 이동하도록)
8. 안티 스케이트 다이얼을 3으로 설정합니다.

후면에서

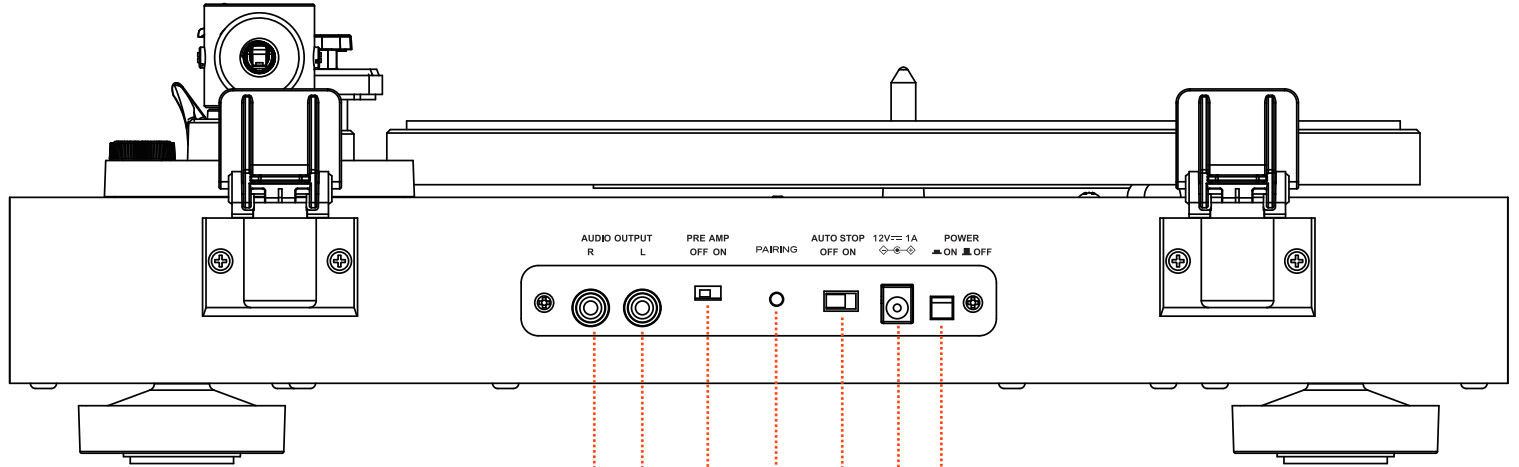

1. 아날로그 출력
2. 프리앰프 끄기/켜기
(앰프의 Phono 입력에 연결된 경우 끄기)
3. Bluetooth 버튼
4. 자동 시작/중지
(플래터의 자동 시작 및 중지 활성화)
5. 전원 입력부
6. 전원 스위치

Bluetooth 페어링

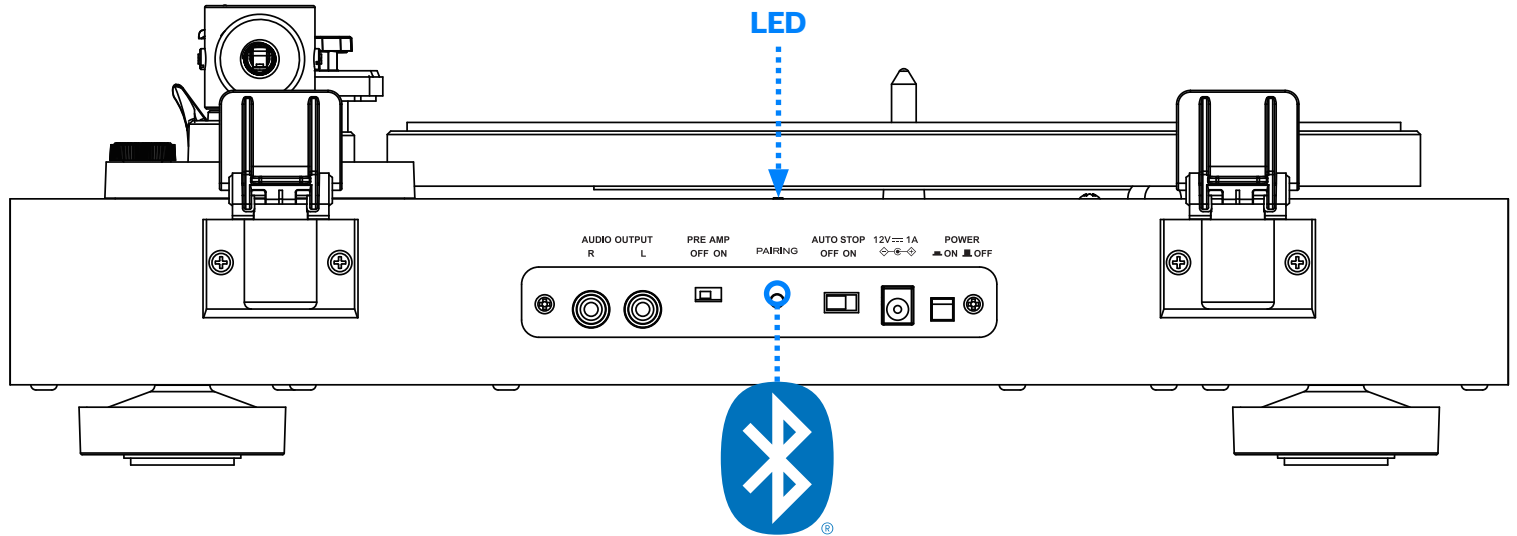

페어링 모드 = 2초 동안 버튼 길게 누르기 + 파란색 LED 점멸

연결됨 = 파란색 LED 점등

재연결 = 버튼 탭하기(파란색 LED 점멸 = 연결 중)

페어링 레코드 삭제 = 10초 동안 버튼 길게 누르기

레코드 재생

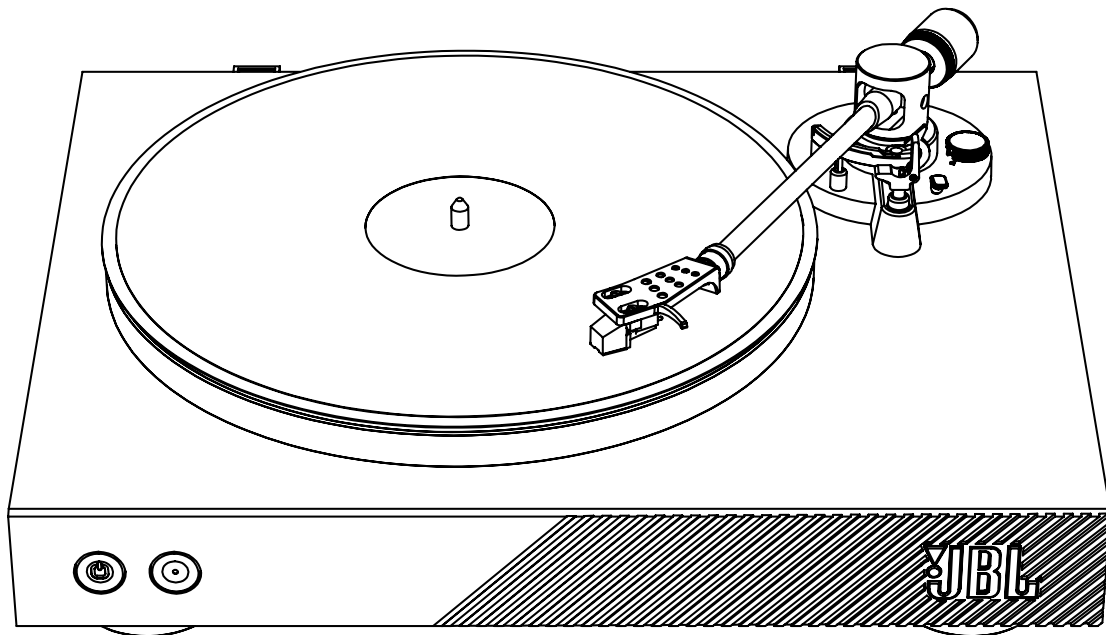

한 단계씩 수행하십시오.

1. 스타일러스 커버 제거
2. 레코드를 플래터에 놓습니다(재생 중인 레코드 표면을 건드리지 않는 것이 가장 좋음)
3. 나머지 부분에서 톤암을 분리합니다
4. 암 리프트 레버를 들어올립니다
5. 카트리지가 레코드 시작 부분 위로 오도록 톤암을 움직입니다
6. 재생 중인 레코드에 따라 플래터를 33 또는 45로 시작합니다
7. 암 리프트 레버를 내리면 암이 레코드판으로 부드럽게 내려갑니다



FR
Cet appareil,
ses accessoires
et cordons
se recyclent

À DÉPOSER
EN MAGASIN

OU

À DÉPOSER
EN DÉCHÈTERIE

Points de collecte sur www.quefairedemesdechets.fr



GUIA DE INÍCIO RÁPIDO



SPINNERBT

CONTEÚDO DA CAIXA

1. Tapete do prato
2. Prato
3. Cabeçote e cápsula
4. 2 x Dobradiças da tampa
5. Adaptador individual
6. Contrapeso
7. Cabo de conexão
8. Correia (instalada no prato)
9. Fonte de energia*

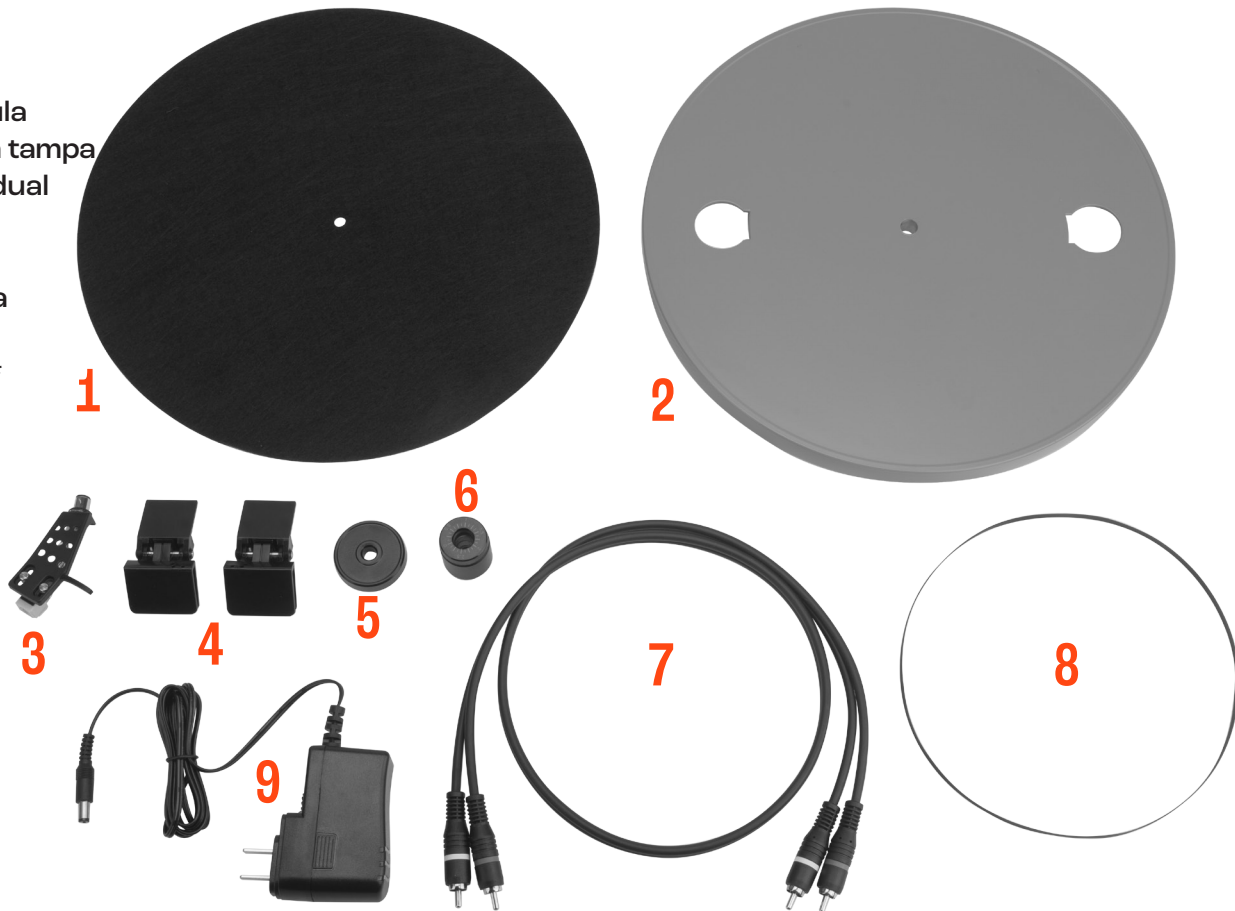

*O CABO DE ALIMENTAÇÃO E O TIPO DE TOMADA VARIAM DE ACORDO COM A REGIÃO

MONTAGEM

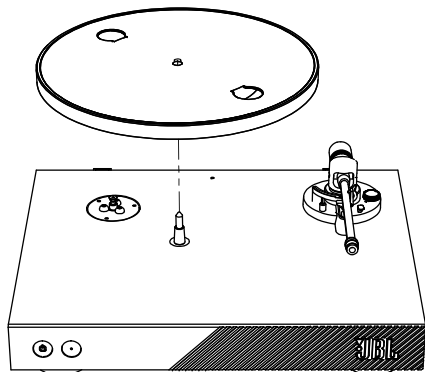

1. Instale o prato

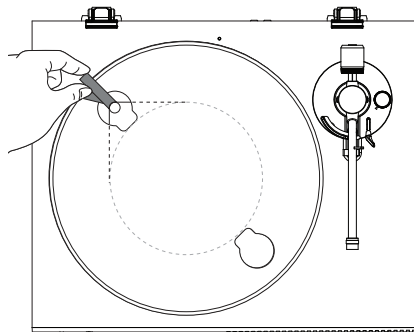

2. Instale a correia ao redor da polia do motor

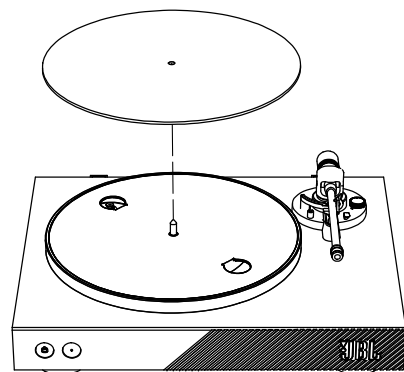

3. Instale o tapete do prato

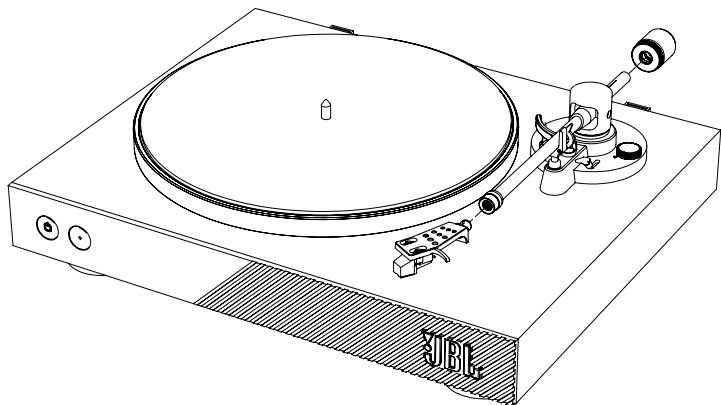

4. Instale o cabeçote

5. Instale o contrapeso

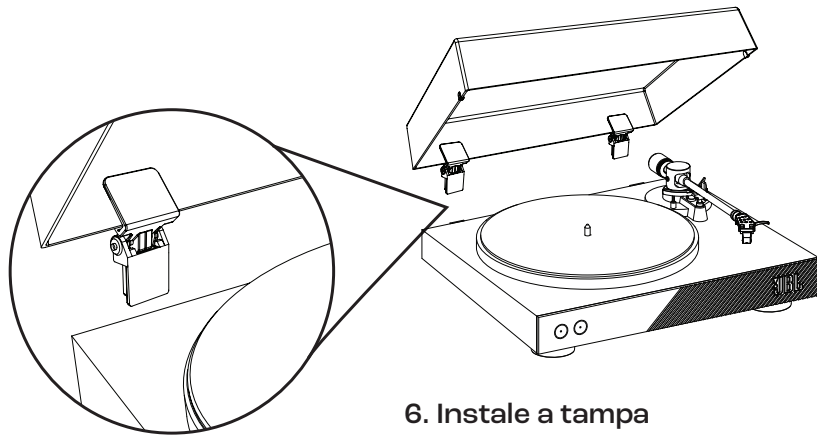

6. Instale a tampa

AJUSTE DO BRAÇO

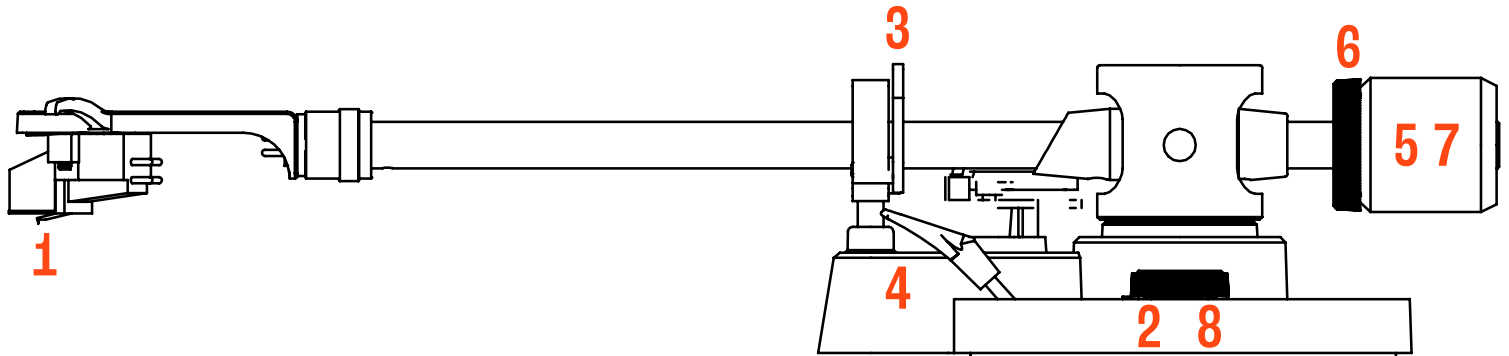

Uma etapa de cada vez...

1. Remova a tampa da agulha – cuidado com a ponta da agulha!
2. Verifique se o anti-skating está ajustado para 0
3. Retire o braço da base
4. Verifique se a alça do braço está posicionada para baixo
5. Gire o contrapeso até que o braço flutue (ele deve ficar parado, sem subir ou descer)
6. Ajuste o botão do contrapeso para 0 na parte superior (cuidado para não mover o contrapeso)
7. Com o botão em 0, gire o contrapeso 1 volta completa no sentido anti-horário (para que o contrapeso se desloque em direção à cápsula)
8. Ajuste o botão anti-skating para 3.

NA PARTE TRASEIRA

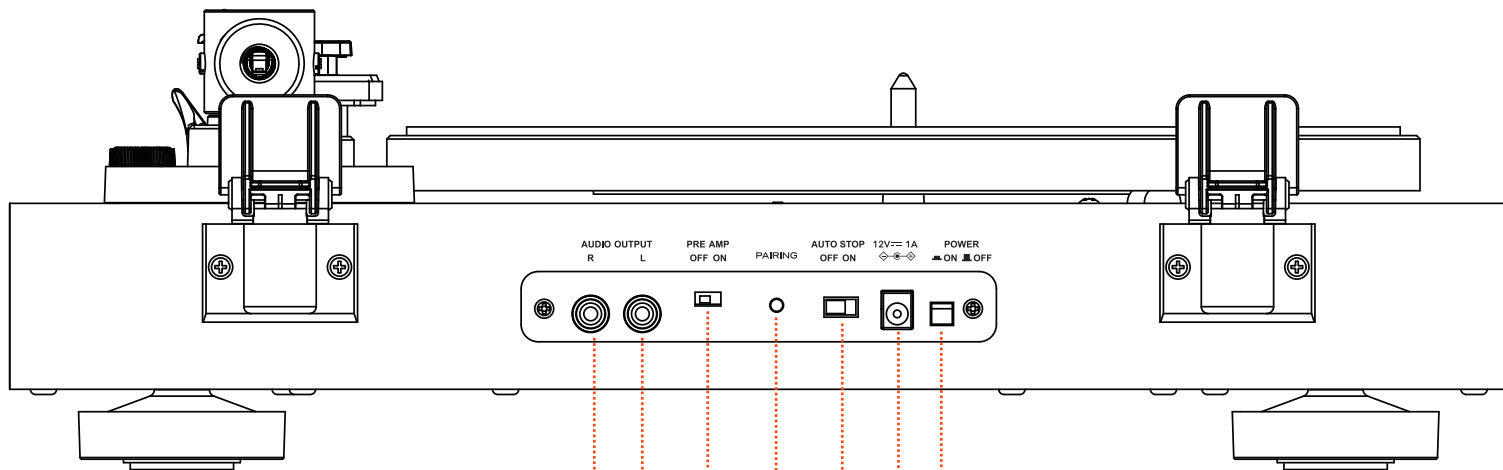

1. Saídas analógicas
2. Pré-amplificador desligado/ligado
(desligar quando conectado à entrada Phono de um amplificador)
3. Botão Bluetooth
4. Iniciar/parar automático
(Ativa o início e parada automáticos do prato)
5. Entrada de potência
6. Interruptor de energia

EMPARELHAMENTO BLUETOOTH

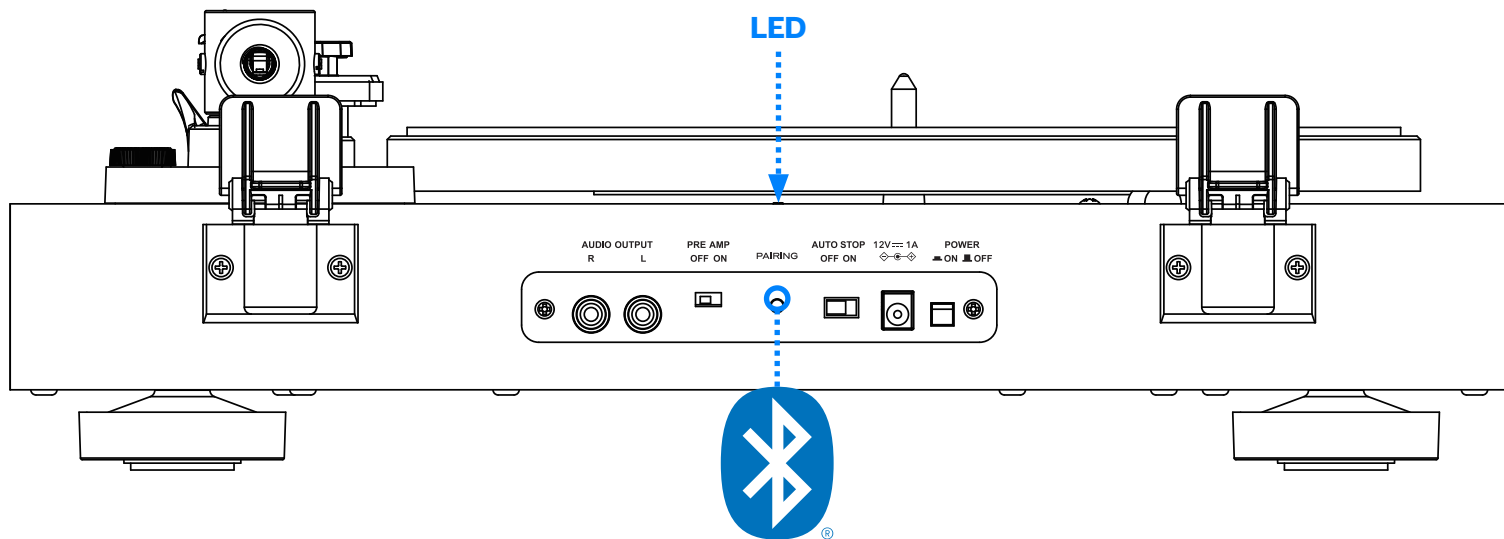

Modo de emparelhamento = Pressione e mantenha pressionado o botão por dois segundos + Luz LED azul piscando

Conectado = Luz LED azul constante

Reconectar = Toque no botão (Luz LED azul piscando = conectando)

Limpar registro de emparelhamento = Pressione e mantenha pressionado por 10 segundos

REPRODUÇÃO DE DISCOS

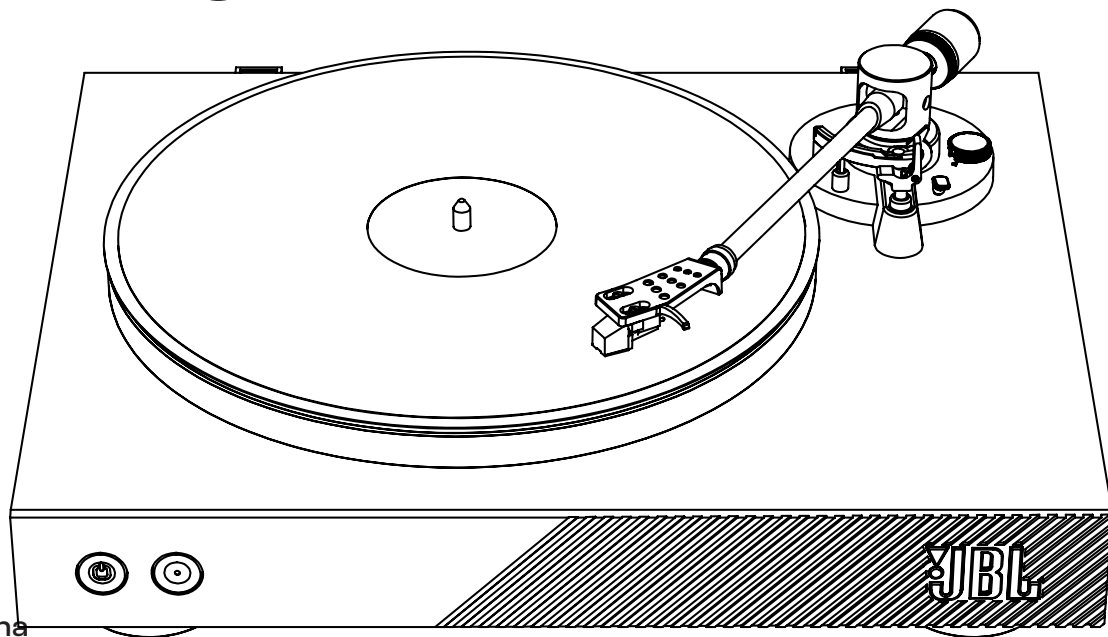

Uma etapa de cada vez...

1. Remova a tampa da agulha
2. Coloque o disco no prato (é melhor evitar tocar na superfície de reprodução)
3. Retire o braço da base
4. Levante a alça do braço
5. Mova o braço para que a cápsula fique sobre o início do disco
6. Ajuste o prato para 33 ou 45, conforme o disco que você está reproduzindo
7. Baixe a alça do braço – o braço descenderá suavemente até o disco



Points de collecte sur www.quefairedemesdechets.fr



GUIDE DE DÉMARRAGE RAPIDE



SPINNERBT

CONTENU DE LA BOÎTE

1. Tapis de plateau
2. Plateau
3. Porte-cellule et cellule
4. 2 charnières de couvercle anti-poussière
5. Adaptateur unique
6. Contrepoids
7. Câble de connexion
8. Courroie (montée sur le plateau)
9. Alimentation*

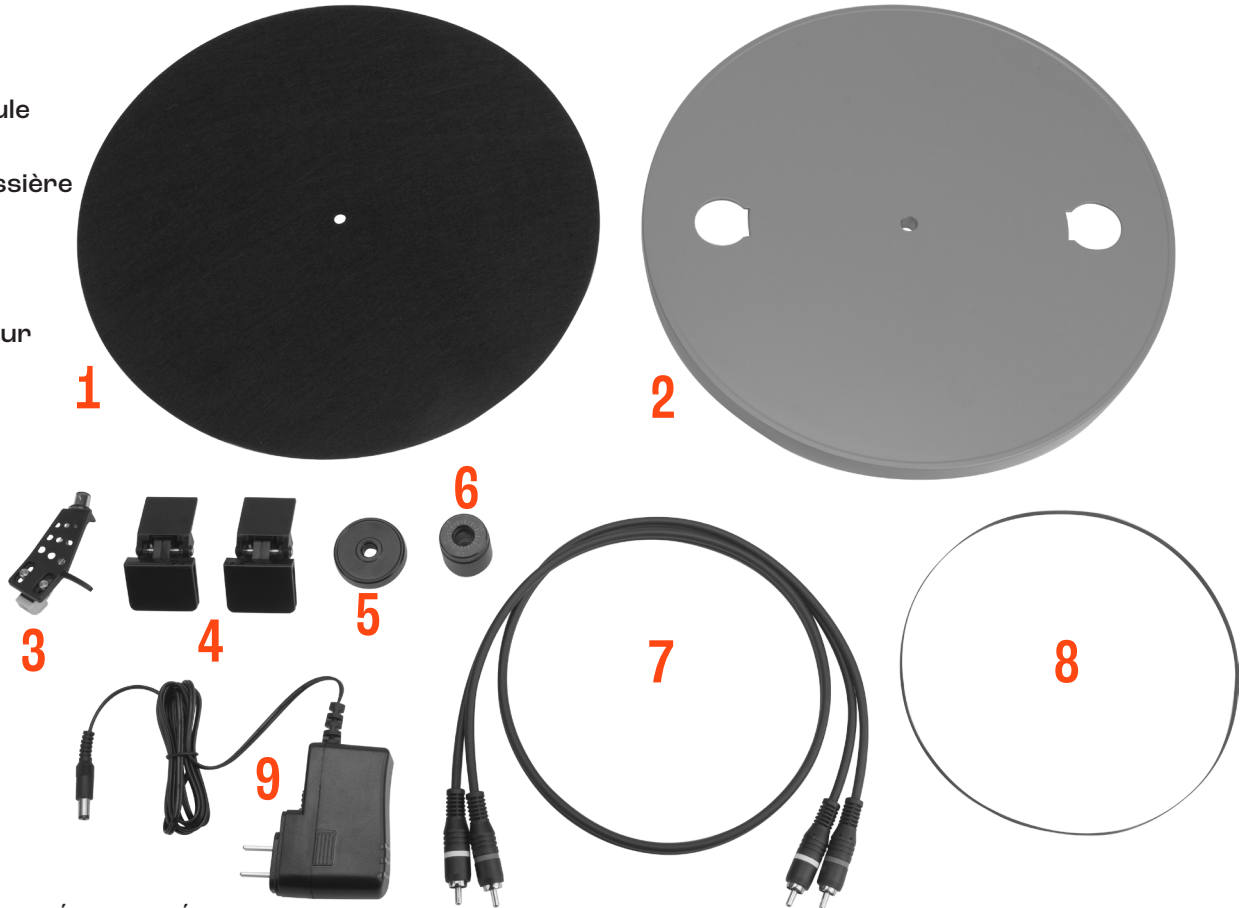

* LE TYPE DE FICHE DE L'ALIMENTATION DÉPEND DE LA RÉGION

ASSEMBLAGE

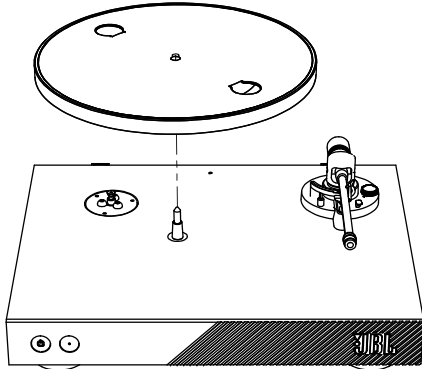

1. Montez le plateau

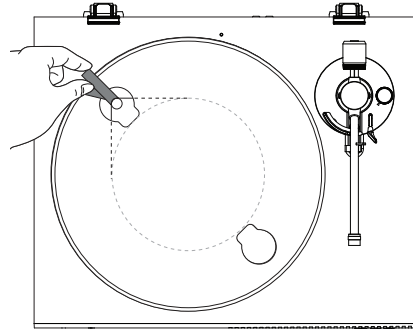

2. Placez la courroie autour de la poulie du moteur

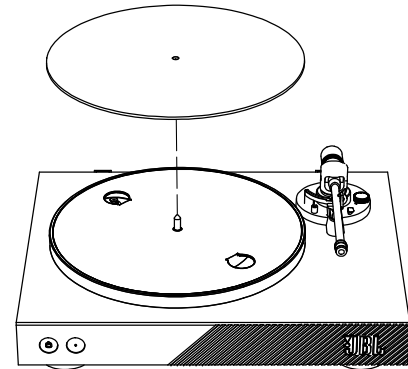

3. Montez le tapis du plateau

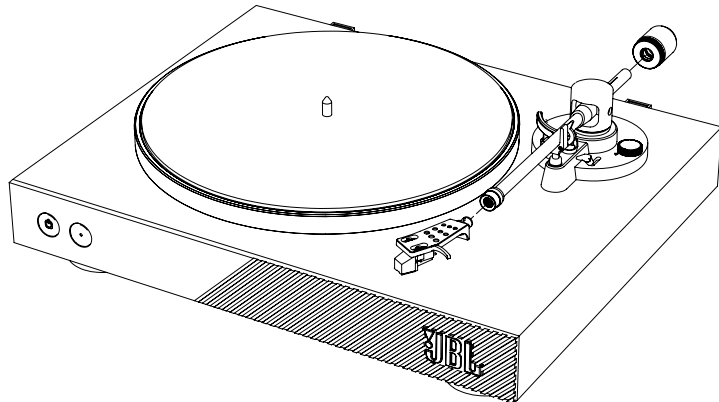

4. Montez le porte-cellule

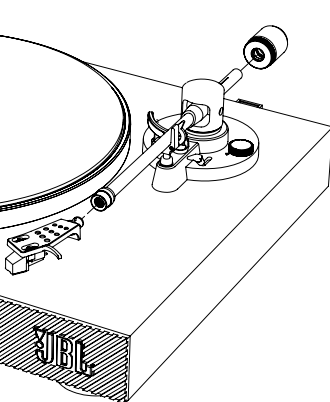

5. Montez le contrepois

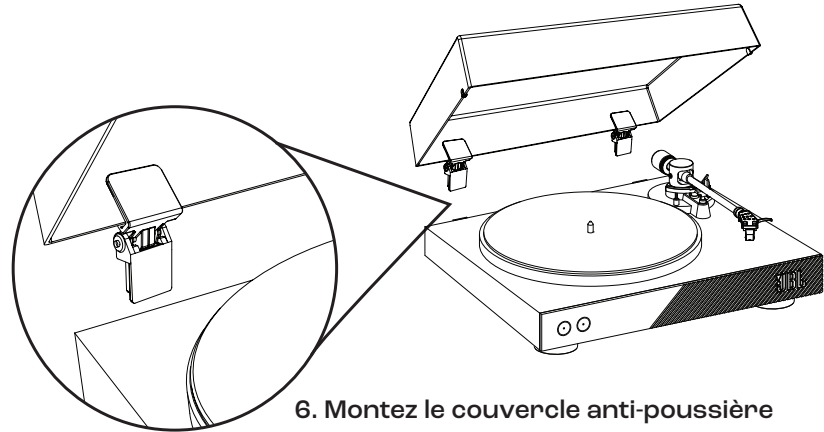

6. Montez le couvercle anti-poussière

ÉQUILIBRAGE DU BRAS

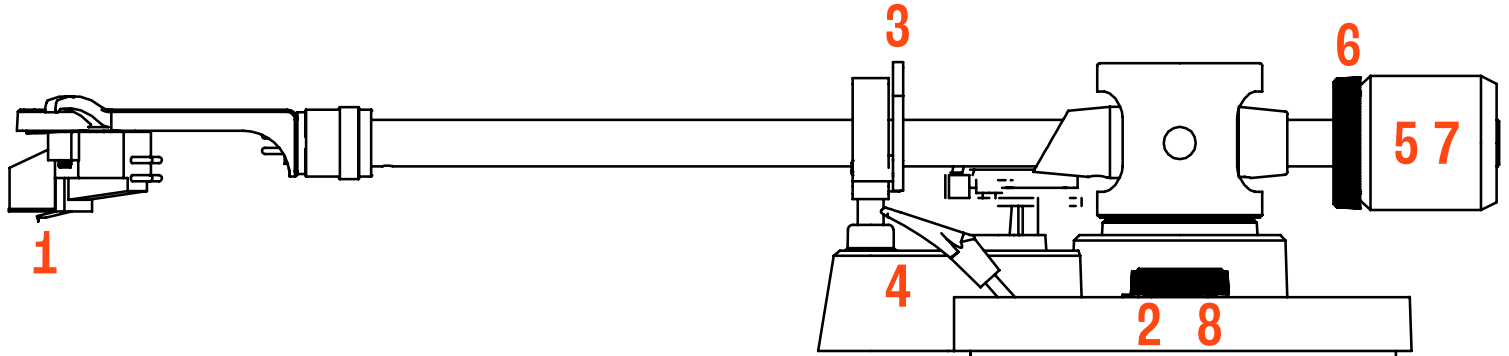

Une étape à la fois...

1. Retirez le capuchon de l'aiguille - faites attention à l'aiguille !
2. L'antipatinage doit être réglé sur 0
3. Détachez le bras de son support
4. Le levier du bras doit être en position abaissée
5. Tournez le contrepoids jusqu'à ce que le bras flotte (il ne doit ni monter, ni descendre)
6. Réglez la graduation du contrepoids avec le 0 en haut (attention à ne pas déplacer le contrepoids)
7. Avec la graduation sur 0, tournez le contrepoids sur 1 tour complet dans le sens antihoraire (le contrepoids se déplace vers la cellule)
8. Réglez la graduation de l'anti-patinage sur 3.

À L'ARRIÈRE

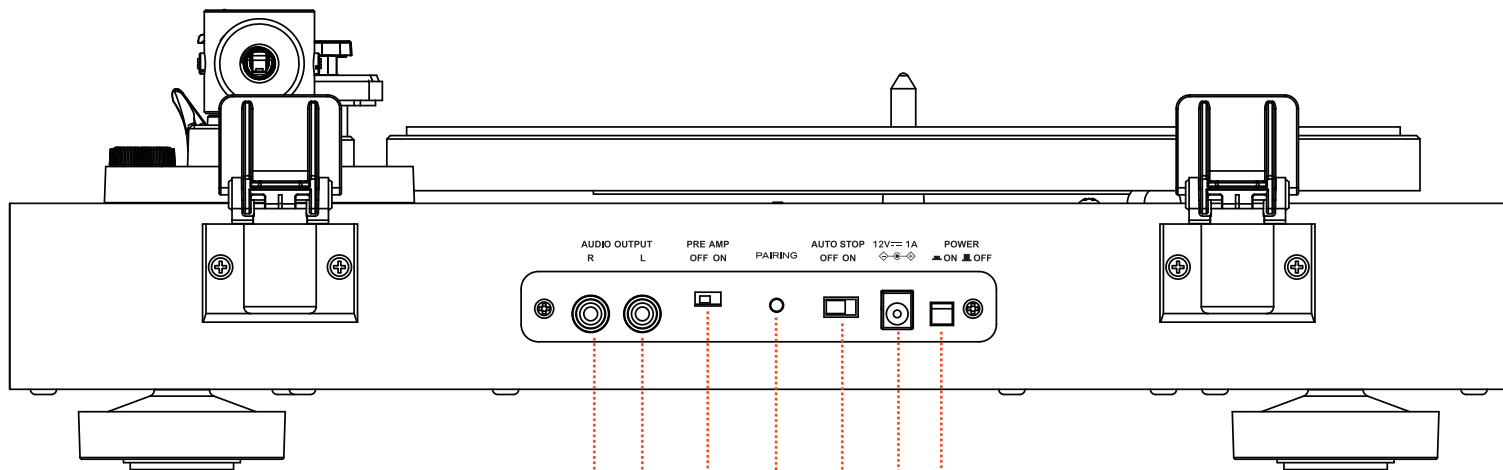

1. Sorties analogiques
2. Marche/arrêt du préamplificateur
(Le mettre sur off (arrêt) en cas de connexion à l'entrée Phono de l'amplificateur)
3. Bouton Bluetooth
4. Démarrage/arrêt automatique
(Active le démarrage et l'arrêt automatiques du plateau)
5. Prise d'alimentation
6. Commutateur d'alimentation

JUMELAGE BLUETOOTH

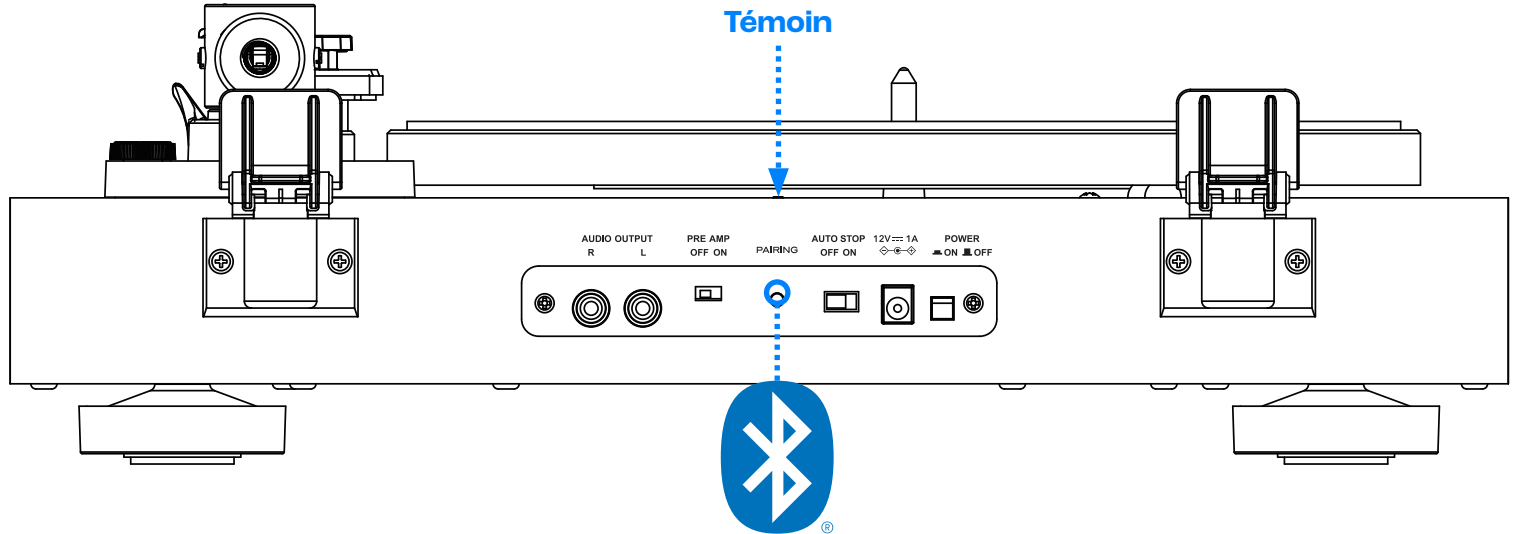

Jumelage = appuyez pendant 2 secondes sur le bouton + témoin bleu clignotant

Connecté = témoin bleu fixe

Reconnexion = appuyer sur le bouton (témoin bleu clignotant = connexion en cours)

Effacement du jumelage = appuyer pendant 10 secondes.

LECTURE DE DISQUES

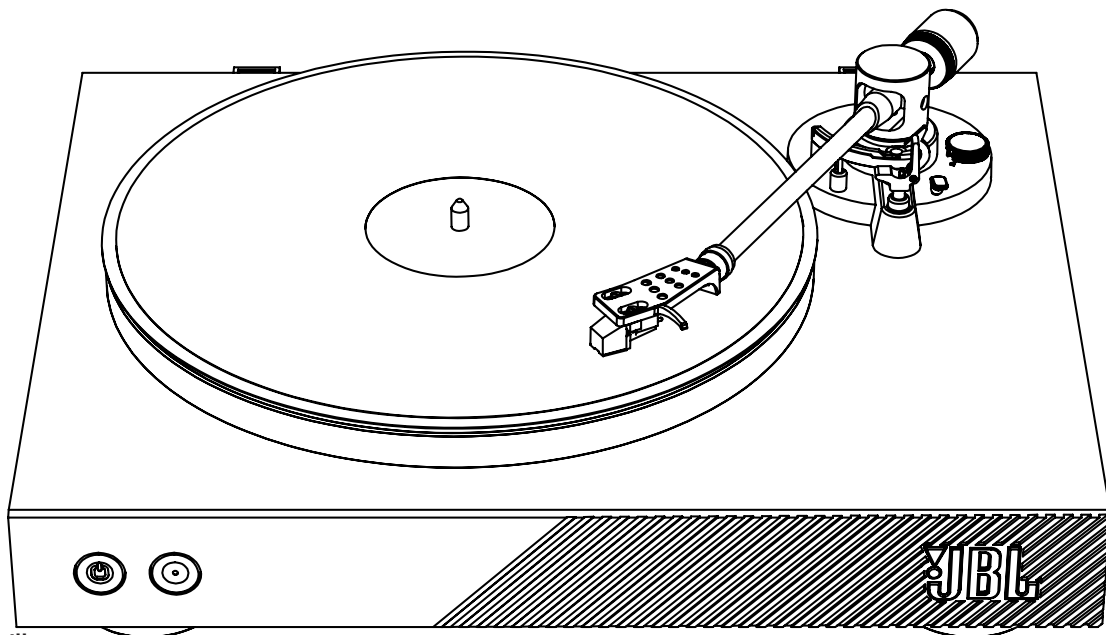

Une étape à la fois...

1. Retirez le capuchon de l'aiguille
2. Placez votre disque sur le plateau (il est préférable d'éviter de toucher la surface du disque)
3. Détachez le bras de son support
4. Levez le levier de levage du bras
5. Déplacez le bras pour mettre la cartouche au-dessus du début du disque
6. Démarrez le plateau à 33 ou 45 selon le type de disque que vous écoutez
7. Abaissez le levier de levage du bras - le bras s'abaisse doucement sur le disque



FR
Cet appareil,
ses accessoires
et cordons
se recyclent

À DÉPOSER
EN MAGASIN



OU

À DÉPOSER
EN DÉCHÈTERIE



Points de collecte sur www.quefairedemesdechets.fr



GUÍA DE INICIO RÁPIDO



SPINNERBT

CONTENIDO DE LA CAJA

1. Alfombrilla de plato
2. Plato
3. Cabezal y cartucho
4. 2 bisagras de la cubierta antipolvo
5. Adaptador único
6. Contrapeso
7. Interconexión
8. Correa (montada en el plato)
9. Alimentación*

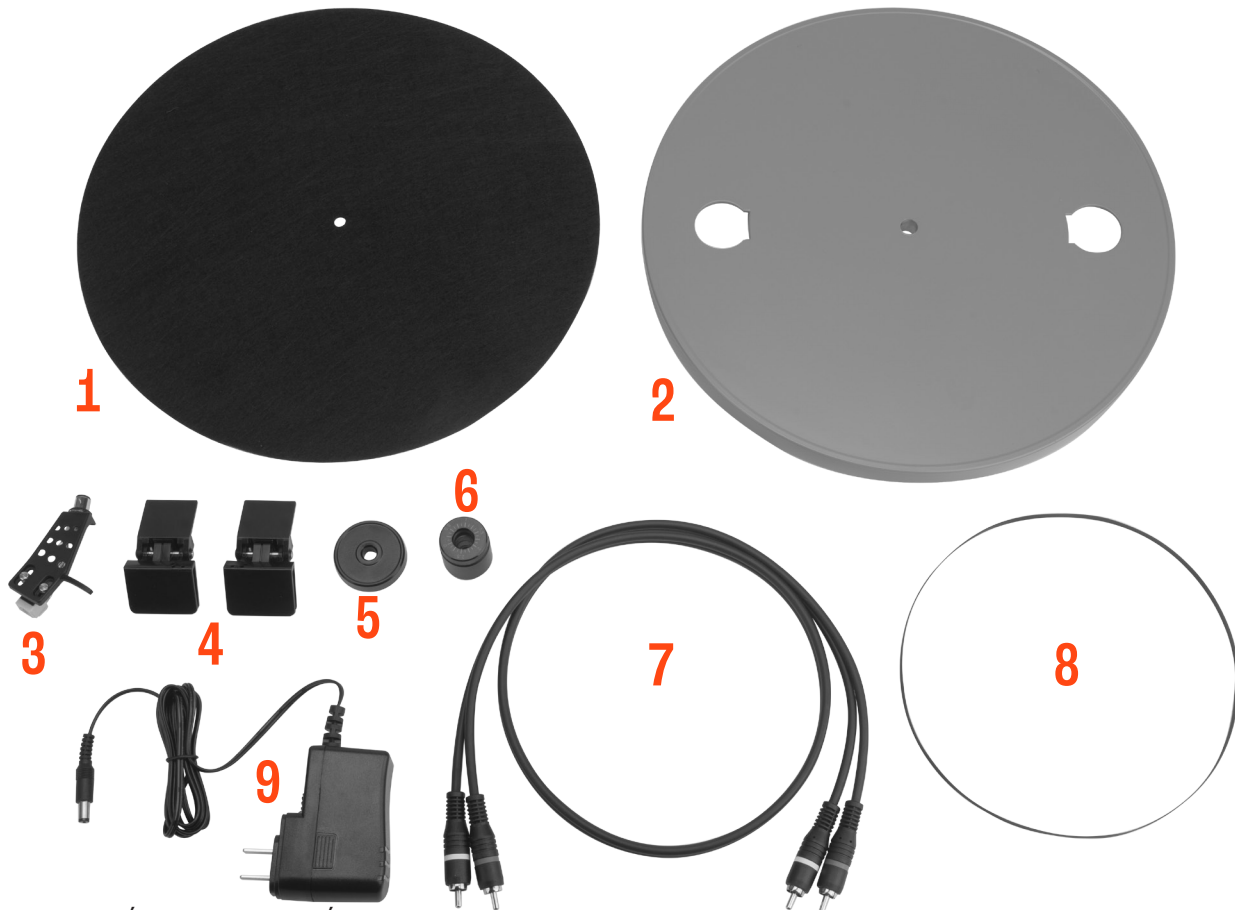

* EL TIPO DE ENCHUFE DEL CABLE DE ALIMENTACIÓN DEPENDE DE LA REGIÓN

MONTAJE

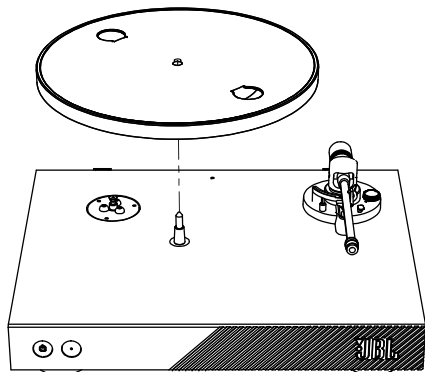

1. Coloca el plato

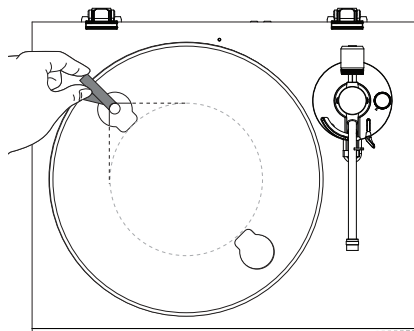

2. Coloca la correa alrededor de la polea del motor

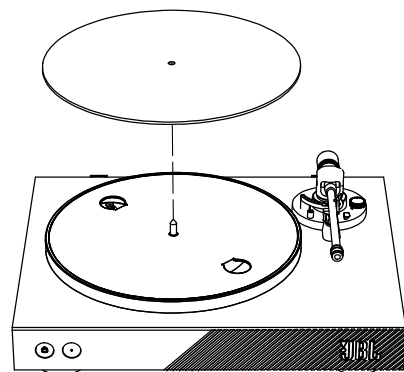

3. Coloca la alfombrilla de plato

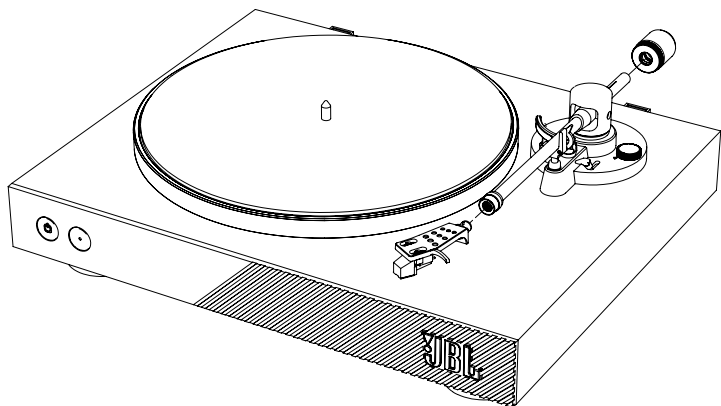

4. Coloca el cabezal

5. Coloca el contrapeso

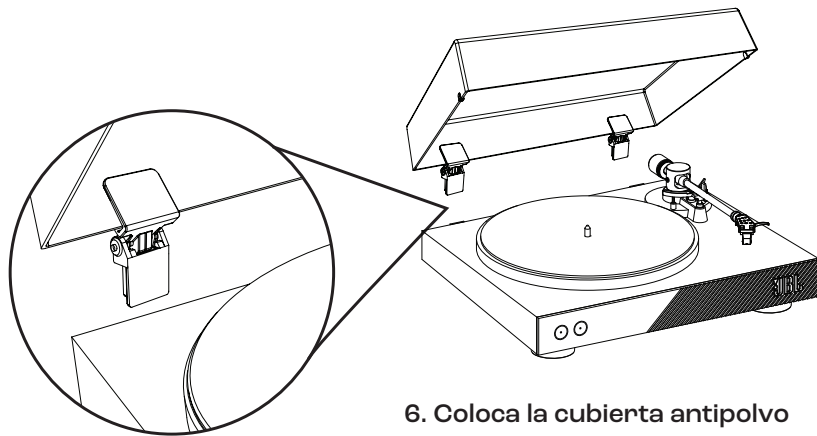

6. Coloca la cubierta antipolvo

EQUILIBRAR EL BRAZO DE LECTURA

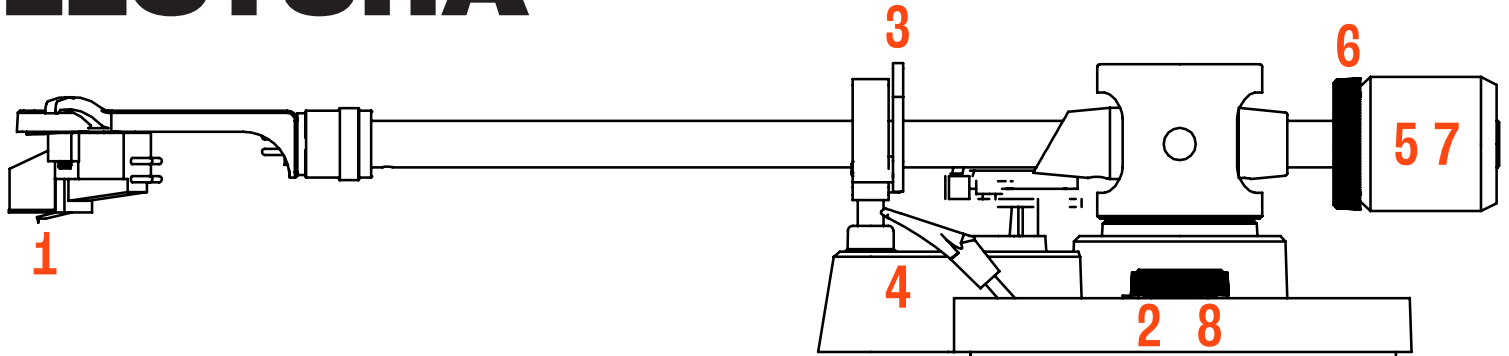

Un paso a la vez...

1. Retira la cubierta del cartucho. ¡Ten cuidado alrededor de la aguja!
2. Asegúrate de que Anti-Skate se establezca en 0
3. Desengancha el brazo de lectura del resto
4. Asegúrate de que el brazo elevador esté en la posición hacia abajo
5. Gira el contrapeso hasta que el brazo flote (no debe seguir subiendo o bajando)
6. Establece el dial del contrapeso en el 0 en la parte superior (ten cuidado de no mover el contrapeso)
7. Con el dial en 0, gira el contrapeso una vuelta completa hacia la izquierda (para que el contrapeso se mueva hacia el cartucho)
8. Establece el dial Anti-Skate en el 3.

EN LA PARTE POSTERIOR

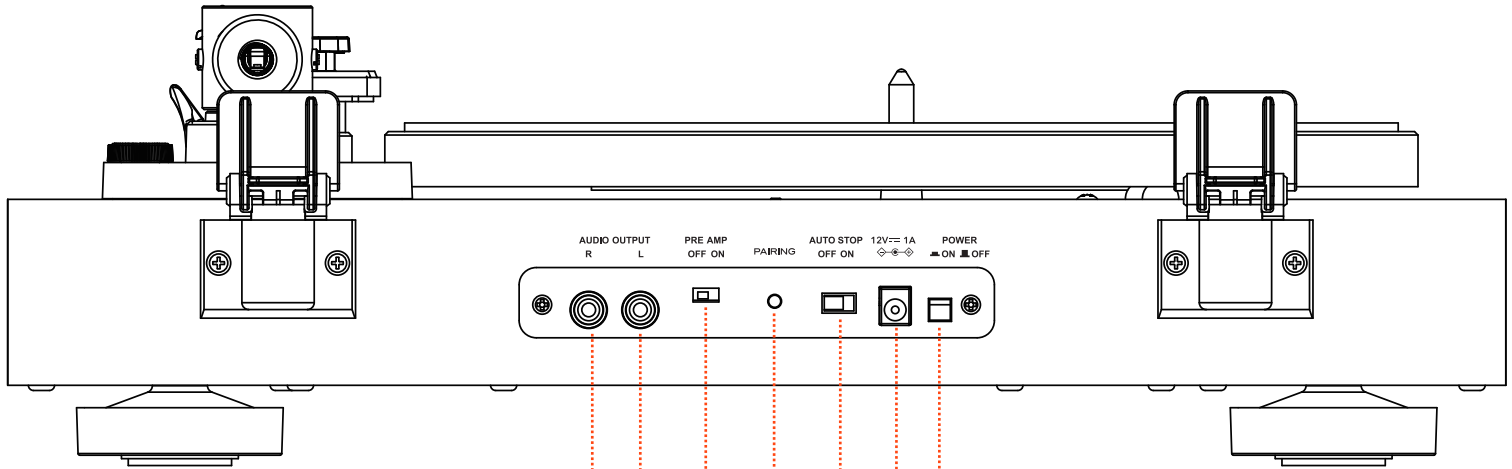

1. Salidas analógicas
2. Preamplificador apagado/encendido
(apágalo al conectar a la entrada Phono de un amplificador)
3. Botón Bluetooth
4. Inicio/pausa automático
(permite el inicio y la pausa automático del plato)
5. Entrada de alimentación
6. Interruptor de alimentación

CONEXIÓN BLUETOOTH

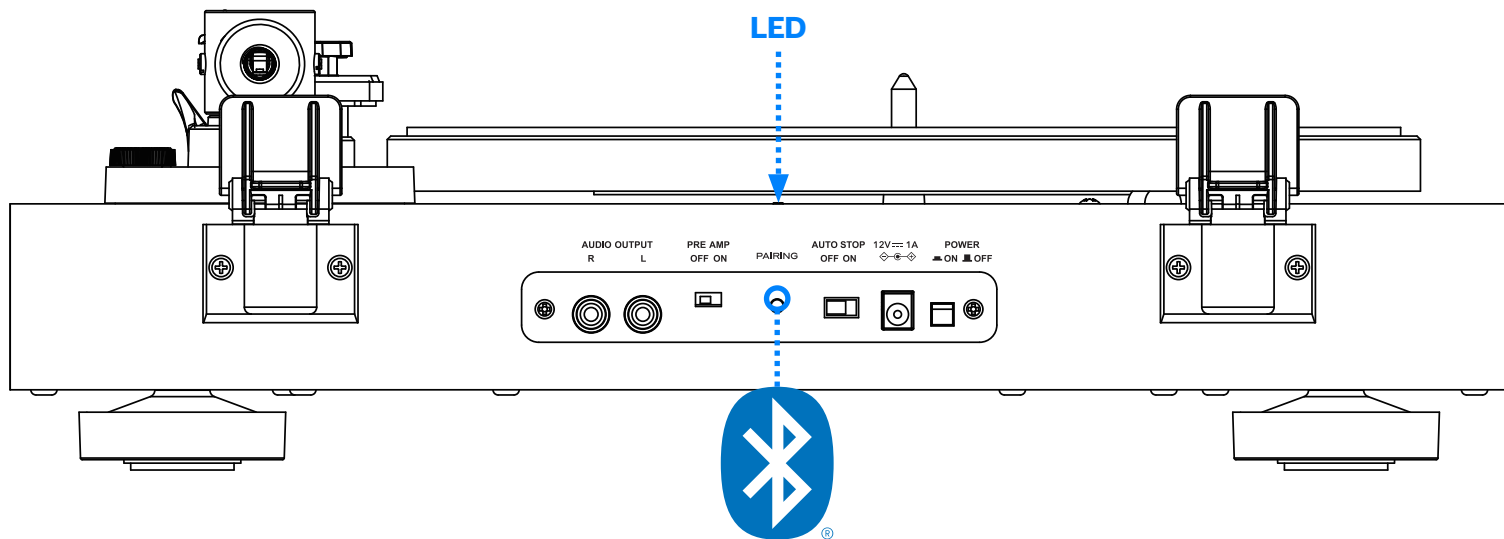

Modo de conexión = Mantén pulsado el botón durante 2 segundos + LED azul parpadeante

Conectado = LED azul fijo

Reconectar = Toca el botón (LED azul parpadeante = Conectando)

Borrar registro de conexión = Mantén pulsado durante 10 segundos

REPRODUCIR DISCOS

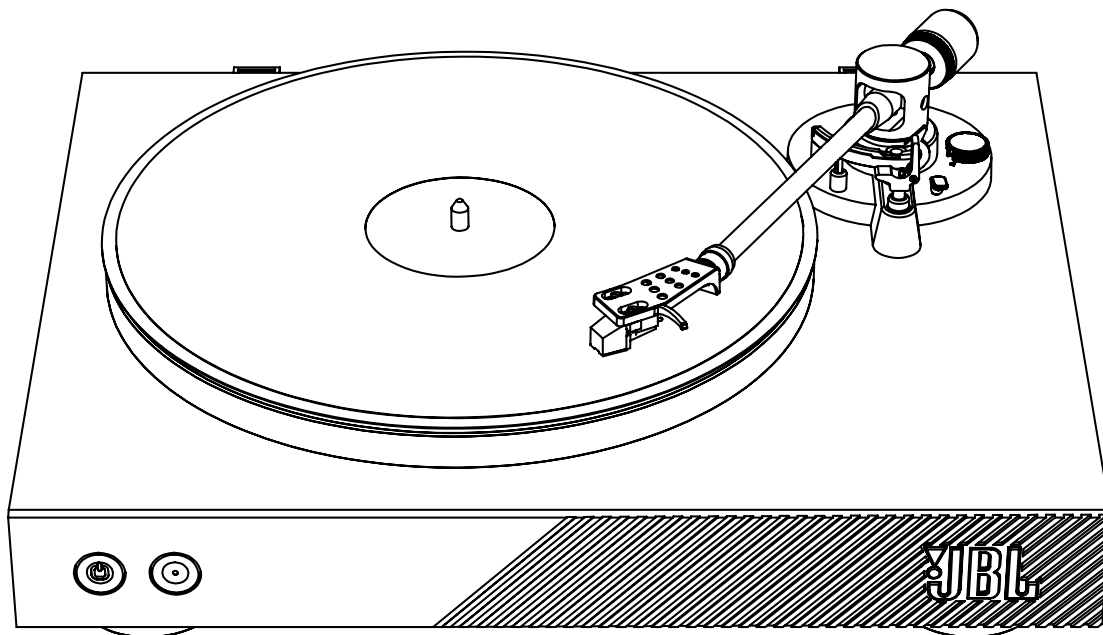

Un paso a la vez...

1. Retira la cubierta del cartucho
2. Coloca tu disco en el plato (es mejor evitar tocar la superficie de reproducción)
3. Desengancha el brazo de lectura del resto
4. Levanta la palanca del brazo elevador
5. Mueve el brazo de lectura para que el cartucho se sitúe sobre el inicio del disco
6. Comienza con el plato a 33 o 45, según lo necesites, para el disco que estás reproduciendo
7. Baja la palanca del brazo elevador: el brazo bajará despacio hasta el disco



Points de collecte sur www.quefairedemesdechets.fr

