



Questo manuale d'istruzione è fornito da trovaprezzi.it. Scopri tutte le offerte per [Metapace T-40](#) o cerca il tuo prodotto tra le [migliori offerte di Macchine per Ufficio](#)

USER'S MANUAL

Thermal Receipt Printer

T-40



Contents

- 1 Introduction1**
 - 1.1 Outline.....1
 - 1.2 Features1
- 2 Specification.....2**
 - 2.1 Technical specification2
 - 2.2 Cutter parameters3
 - 2.3 Paper specification3
 - 2.3.1 Parameters of continuous paper.....3
 - 2.3.2 Parameters of marked paper4
- 3 Appearance and components.....5**
 - 3.1 Appearance and modules5
 - 3.2 LED and buzzer7
- 4 Installation.....8**
 - 4.1 Unpacking8
 - 4.2 Printer installation8
 - 4.3 Power and communication interface9
 - 4.3.1 Power connection9
 - 4.3.2 Interface connection9
 - 4.3.3 USB interface connection.....9
 - 4.3.4 Cash drawer connection9
 - 4.4 Paper roll installation10
 - 4.4.1 Paper type confirmation10
 - 4.4.2 Install/replace paper roll10
 - 4.5 Paper near end position adjustment12
 - 4.6 Power-on and self-test13
 - 4.6.1 Power-on.....13
 - 4.6.2 Print self-test page13
 - 4.7 Hexadecimal dumping function14
- 5 Routine maintenance.....15**
 - 5.1 Cleaning the print head and the platen roller15

- 5.2 Cleaning the mark sensor..... 15
- 5.3 Clearing the jammed paper and the cutter error 15
- 6 Interface signal..... 16**
 - 6.1 Serial interface 16
 - 6.2 Parallel interface..... 16
 - 6.3 USB interface 18
 - 6.4 Ethernet interface 18
 - 6.5 Double communication interface..... 19
 - 6.6 Power interface definition 20
 - 6.7 Cash drawer interface signal definition 20
- 7 Troubleshooting 22**
 - 7.1 Printer doesn't work 22
 - 7.2 Error LED and buzzer alarm 22
 - 7.3 Problems during printing 22
- 8 Power management 23**
- 9 DUMP mode 24**
- Appendix Button configuration 25**

1 Introduction

1.1 Outline

T-40 is developed for high-end thermal receipt printing market, which is widely used. T-40 can be connected with other devices via serial, parallel, USB, Bluetooth, Ethernet and WLAN. It provides drivers for operation systems such as Windows 2000 / XP / Server 2003 / Vista / Server200 / Win7 / Win8 / Win8.1 / Win10 / Server 2012, POSReady2009 / POSReady7, Linux, Mac and UPOS middleware.

Note: Windows and Linux drivers support 64-bit operation system.

1.2 Features

- Low noise, high printing speed;
- Support continuous paper, marked paper;
- Support paper saving, water mark, upside-down, two-color printing, etc.;
- Compact size, can output paper from the front or the top according to users' different demands;
- Rich interfaces: USB(fix on board), expandable serial / parallel / Ethernet / Bluetooth / WIFI / serial + Ethernet interface;

2 Specification

2.1 Technical specification

Item		Parameter
Printing	Print method	Direct thermal line printing
	Resolution	203 × 203 DPI; 203 × 180 DPI
	Paper width	57.5/80/82.5 mm
	Print width	Max.80 mm
	Print speed	Max.250 mm/s
	Flash LOGO	Max. 1M bytes
	Command buffer area	64K bytes, 4K bytes or 45 bytes
Interface	USB	USB 2.0 (full speed)
	Serial interface	RS-232C
	Parallel interface	IEEE1284
	Ethernet interface	10/100BASE-T
	Cash drawer	Can select to controlling 1~2 cash drawers
Memory		RAM: 2 MB, Flash: 4 MB
Printer status detection		Paper end sensor/ black mark sensor; Paper near end sensor; Cover position sensor; Paper presence sensor Print head temperature sensor; Printer voltage detection
Cut mode		Full cut, partial cut
Barcode	1D	UPC-A, UPC-E, CODE 39, CODE 93, CODE 128, EAN8, EAN13, ITF, CODABAR
	2D	PDF417, QR, Maxicode
Fonts		Font A: 12 × 24 Font B: 9 × 17 Kanji font A: 24 × 24
Character set		95 Alphanumeric
		14 types of international characters
		128 x 68 code page
		Optional: Traditional Chinese, Simplified Chinese (GB2312/18030), Japanese, Korean, English, HK
		User-defined font (95) & code page
Character enlargement		All characters can be enlarged 1-6 times horizontally and vertically
Character rotation		Rotation printing in four directions (0°, 90°, 180°, 270°)
Command		ESC/POS compatible
Paper	Paper type	Thermal continuous paper Thermal marked paper
	Paper roll OD	Max. 83 mm

	Paper thickness	0.06 mm~0.10 mm thermal paper
Power supply	Input	100-240V AC, 50-60 Hz
	Output	24V ± 5% DC, average current 2A
	External or not	External power adapter
Human-machine interface	Power switch	Support
	Button	Support
	LED	Support, including POWER LED and ERROR LED
	Buzzer	Support, 24V buzzer
Reliability	Lifetime of print head	≥150Km (standard test sample with 12.5% duty ratio)
	Lifetime of cutter	2,000,000 cuts (standard test condition)
	MCBF	70,000,000 lines
	MTBF	360,000 hours (main control board)
Operation temperature and humidity		5°C~45°C, 20%~90% RH(40°C)
Storage temperature and humidity		-40°C~60°C, 10%~90% RH(40°C)
Overall dimensions		127mm(L)*127mm(W)*134mm(H)
Functions	Saving paper	Support
	Button configuration	Support (configure the printer without computer)
	Right-up-side printing	Support
	Water mark printing	Support
	Gray scale printing	Support

Table 2.1-1 Technical specifications

2.2 Cutter parameters

Item	Parameter	Remarks
Cutting method	Sliding blade	
Cutting time	500 ms	The time of one cut
Cutting interval	3 s	20 cuts/minute (Max.)
Applicable paper types	0.06 mm~0.10 mm thermal paper	
Operation voltage	24V DC	
Max. operation current	1.2A	Operation voltage 24V DC
Cutter lifetime	2,000,000 cuts	Standard test condition

Table 2.2-1 Technical parameters of cutter

2.3 Paper specification

2.3.1 Parameters of continuous paper

- Paper type: thermal paper
- Paper supply mode: paper roll
- Paper width: 57.5/80/82.5 mm
- Paper thickness: 0.06 mm-0.10 mm
- Thermal layer: outward
- Paper roll specification: paper roll OD Max φ83 mm, core ID Min. φ12.8 mm

➤ Paper recommended:

Paper model	Manufacturer
600-3.1	APPLETON Papers Inc
KLS_46_e	KANZAN Spezialpapiere GmbH
FD210	OJI Paper CO., LTD.

Table 2.3-1 Recommended thermal paper model

2.3.2 Parameters of marked paper

T-40 can support marked paper printing and set the cutting and initial printing position accurately. The marked paper not only should meet the specifications of thermal paper roll, but also should meet the following requirements:

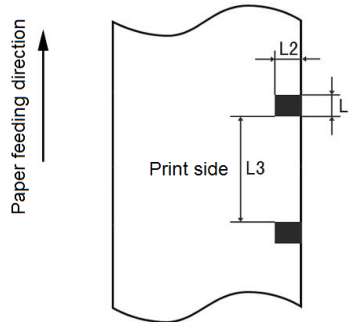

- L1 mark height: $3\text{ mm} \leq L1 \leq 13\text{ mm}$
- L2 mark length: $L2 \geq 8\text{ mm}$
- L3 distance between two marks: $30\text{ mm} \leq L3 < 450\text{ mm}$
- Thermal side mark sensor position: reserved the left/middle/right positions
- Non-thermal side mark sensor position: the middle/left/right position is selectable
- Reflectivity: The reflectivity of the black mark must be no more than 15% while the reflectivity of the paper itself should exceed 85%. There should be no image between the two marks, such as the advertisement, etc.

⚠ Caution:

- ✧ Please use the recommended paper or its equivalents. Using the paper of low quality might affect the print quality and shorten the lifetime of print head;
- ✧ Do not stick paper onto the core shaft;
- ✧ If the paper is contaminated by chemical or oil, it may discolor or lose heat sensitivity at the polluted spot, which will affect the print affect;
- ✧ Do not rub the paper surface with hard objects, otherwise it may affect the print affect;
- ✧ When the environment temperature goes up to 70°C , paper will discolor. Thus don not use or store paper under high temperature, high humidity and strong light conditions.
- ✧ The mark is measured during printing and paper feeding. If the mark height value detected by the sensor is bigger than the default value (default setting is 13mm), the printer will alarm paper end.

3 Appearance and components

3.1 Appearance and modules

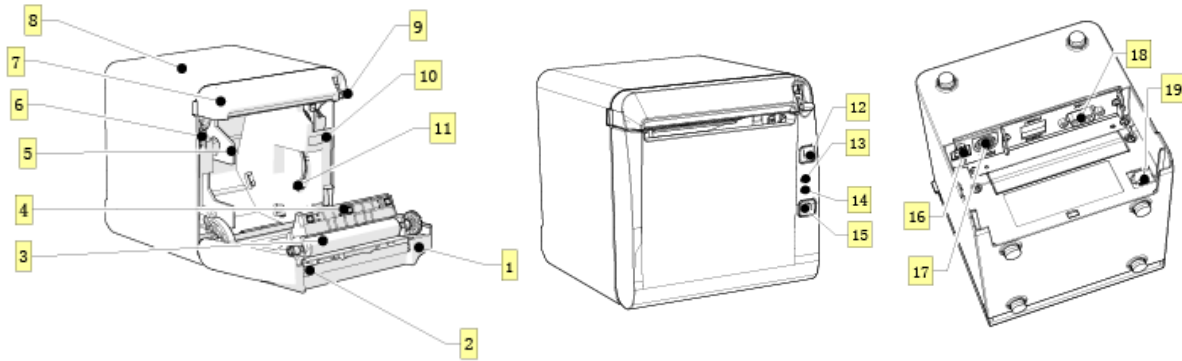

Fig. 3.1-1 Schematic drawing of appearance and modules

- | | | |
|--------------------------|--------------------------|----------------------------|
| 1—Top cover | 2—Cutter | 3—Platen roller |
| 4—Paper end sensor | 5—Paper guide | 6—Micro switch |
| 7—Cutter cover | 8—Middle cover | 9—Cover open spanner |
| 10—Paper cabinet | 11—Paper near end sensor | 12—FEED button |
| 13—ERROR LED | 14—POWER LED | 15—POWER button |
| 16—USB | 17—Power interface | 18—Communication interface |
| 19—Cash drawer interface | | |

Button and component function:

a FEED button (12)

- Feed paper:
Printer will feed paper when the feed button is pressed down under normal condition. To feed paper continuously, keep pressing the button.
- Print configuration sample:
Pressing down the feed button while turning on the power, the printer will print out the configuration sample, which includes print width, print speed, etc.
- Enter button configuration mode:
Press down the feed button while turning on the power, the printer will print out the configuration sample, and enter pause status (error LED flashes) after cutting paper. Keep pressing the feed button at this time, the printer will enter button configuration mode.
- Press the button to clear the cutter error:
Press the button for a short time when a cutter error occurs, the printer will try to clear the cutter error automatically.

b Error LED (13)

Indicate printer status. Under normal status, the error LED is off. Under error status (e.g. paper end, etc.), the error LED flashes.

c Power LED (14)

Indicate printer power status (ON/OFF).

d Power button (15)

Press the button to connect power; press the button for a long time to disconnect the power.

e Top cover status detection sensor (14)

Detect the printer cover status (open/closed).

f Paper presence sensor (12)

Detect the paper presence / absence status when continuous paper is used; detect the paper marks when marked paper is used.

g Spanner for adjusting paper near end sensor(7)

Detect the paper roll status. Fast flashing of error LED indicates that the paper will be used out soon and the user should replace the paper roll in time. Printer will work normally until paper is used out.

h Paper guide (5)

Adjust the position of paper guide in the cabinet to adapt to different paper widths between 58/80mm. When the paper guide is removed, the printer can adapt to 82.5mm paper width.

3.2 LED and buzzer

1) Functions of LED

LED name	Status	Description
Power LED (green)	Always on	Printer power is on.
	Off	Printer power is off.
Error LED (red)	Off	Printer is in normal status.
	Flash	Printer is in error status or paper near end status.
Buzzer	Beep	Printer is in error status.

Table 3.2-1 Functions of LED

2) Error type indicated by LED & buzzer

Error Type	Error LED	Buzzer
Print head is overheating	Cycle flash 6 times	Cycle beep 6 times
Printer voltage is abnormal	Cycle flash 5 times	Cycle beep 5 times
Cutter error	Cycle flash 4 times	Cycle beep 4 times
Print head lift-up	Cycle flash 3 times	Cycle beep 3 times
Paper end	Cycle flash 2 times	Cycle beep 2 times
Paper near end	Cycle flash slowly	No beep
Cannot find mark or mark calibration error	Cycle flash slowly	No beep

Table 3.2-2 LED and indication information

 **Caution:**

- ✧ The temperature of the print head is detected by a thermal resistor. If the print head is overheating, the protective circuit will shut off the power automatically and force the printer to stop printing; the temperature of print head when printing is stopped is 65°C.

4 Installation

4.1 Unpacking

Check whether all items, which are listed on the packing list, are present and in a good condition. If any item is damaged or missing, please contact your dealer or the manufacturer.

4.2 Printer installation

- 1) T-40 supports two working methods: out put the paper from the front or the top when place the printer horizontally on the table. When the printer is placed horizontally on the table, the incline installation angle should not exceed 5°, otherwise the paper near end sensor will not work normally.

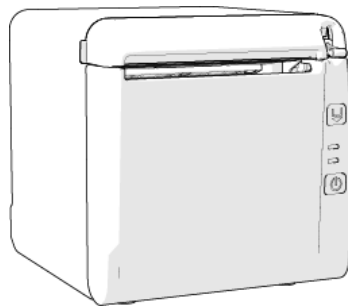

Fig. 4.2-1 Horizontally on the table (paper output from the front)

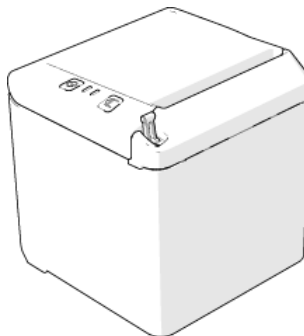

Fig. 4.2-2 Horizontally on the table (paper output from the top)

- 2) Keep the printer far away from water source;
- 3) Do not place the printer in the place exposed to vibration and impact;
- 4) The printer power must be safely grounded;
- 5) It is recommended to keep proper space in order to guarantee the reliability and operational convenience of the printer during operation and maintenance.

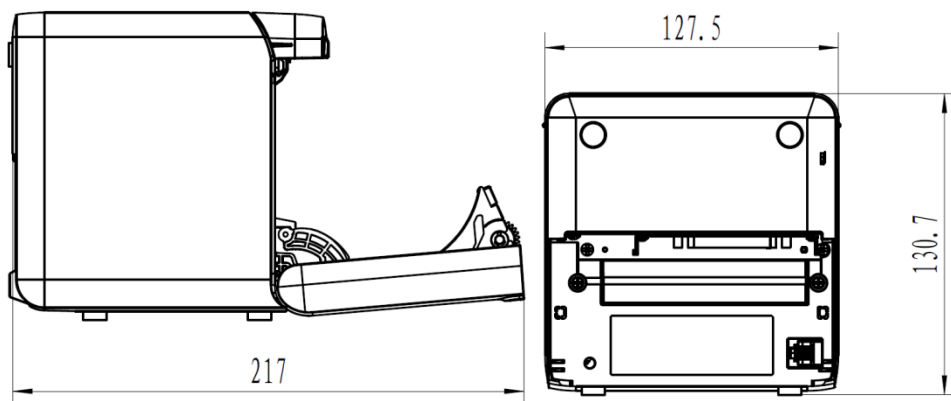
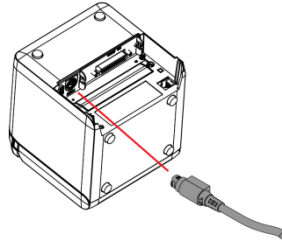

Fig.4.2-3 Printer maintenance and operation space

4.3 Power and communication interface

4.3.1 Power connection



- 1) Ensure that the power switch is turned off;
- 2) Insert the power plug into the corresponding socket on the back of the printer.

⚠ Caution:

- ✧ When the printer is not in use for a long period of time, disconnect the power cord from the printer.

4.3.2 Interface connection

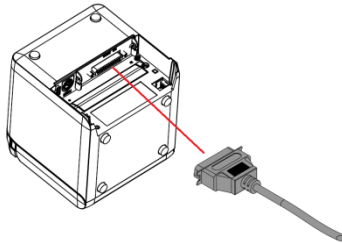

- 1) Ensure that the power switch is turned off;
- 2) Plug the connector into corresponding port and fix it with screw or spring as shown in the figure;
- 3) Connect the other end of cable to the host.

4.3.3 USB interface connection

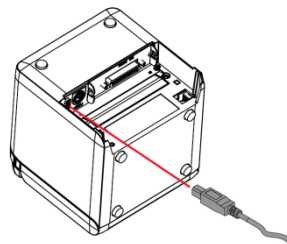

- 1) Ensure that the power switch is turned off;
- 2) Plug the USB cable into corresponding interface in place as shown in the figure;
- 3) Connect the other end of USB cable to the host.

4.3.4 Cash drawer connection

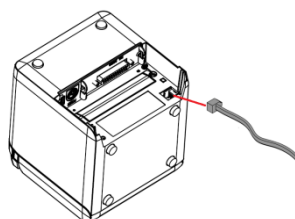

- 1) Ensure that the power switch is turned off;
- 2) Plug the cash drawer cable into the cash drawer interface which locates at the back of printer.

⚠ Caution:

- ✧ The cash drawer interface is used to connect the cash drawer only (cannot connect with phone wire, etc.).

4.4 Paper roll installation

4.4.1 Paper type confirmation

After connecting the power cord and interface cable, confirm paper type after media installation before printing.

4.4.2 Install/replace paper roll

- 1) Turn off the printer;
- 2) Push the spanner in the direction shown in the Fig. to open the top cover;
- 3) Place the paper roll into the printer;
- 4) Close the top cover.

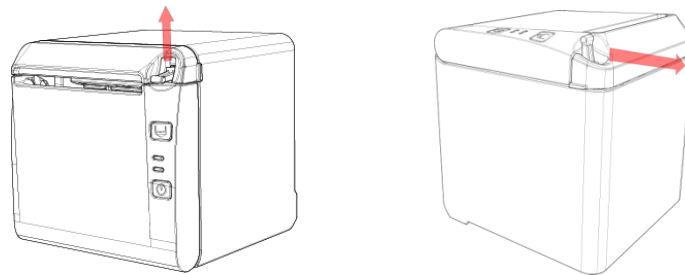

Fig. 4.4-1 Schematic drawing of paper roll installation/replacement

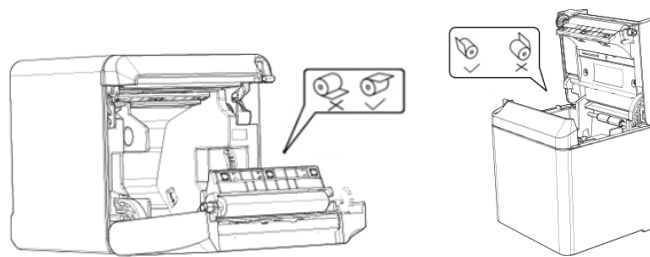

Fig. 4.4-2 Schematic drawing of paper roll installation/replacement

⚠ Caution:

- ✧ Adjust the paper guide according to the paper specification: install the paper guide at the position of 57.5 for 57.5 wide paper roll; install the paper guide at the position of 80 for 80 wide paper roll; and remove the paper guide for 82.5 wide paper roll. Pay attention that the winding direction of paper roll should meet printer requirements. Remove the end in operation hole firstly when disassemble the paper guides, and install the end in operation hole firstly when install the paper guides;



Fig. 4.4-3 Failure model

- ✧ Ensure that the paper roll is tightly wound; otherwise paper jam or other failure may occur (eg. Fig.4-3 Failure model);
- ✧ Paper roll should be placed stably in the paper cabinet without incline, or the printing will be affected.

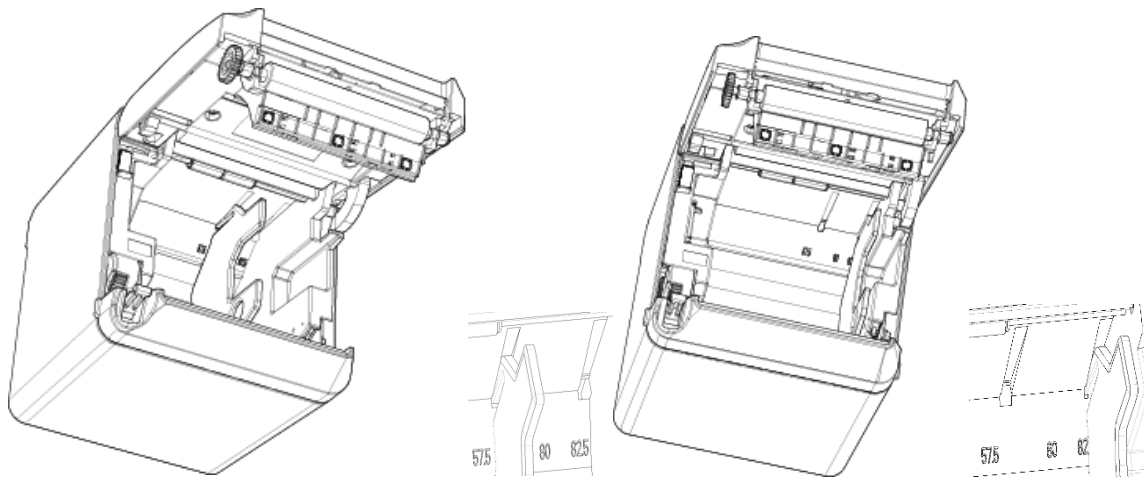

Fig.4.4-4 Position of 57.5 Fig. 4.4-5 Position of 80

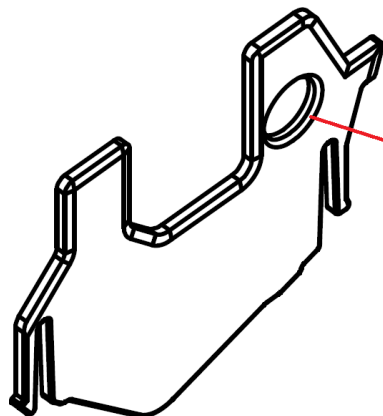

Fig. 4.4-5 Operation hole

4.5 Paper near end position adjustment

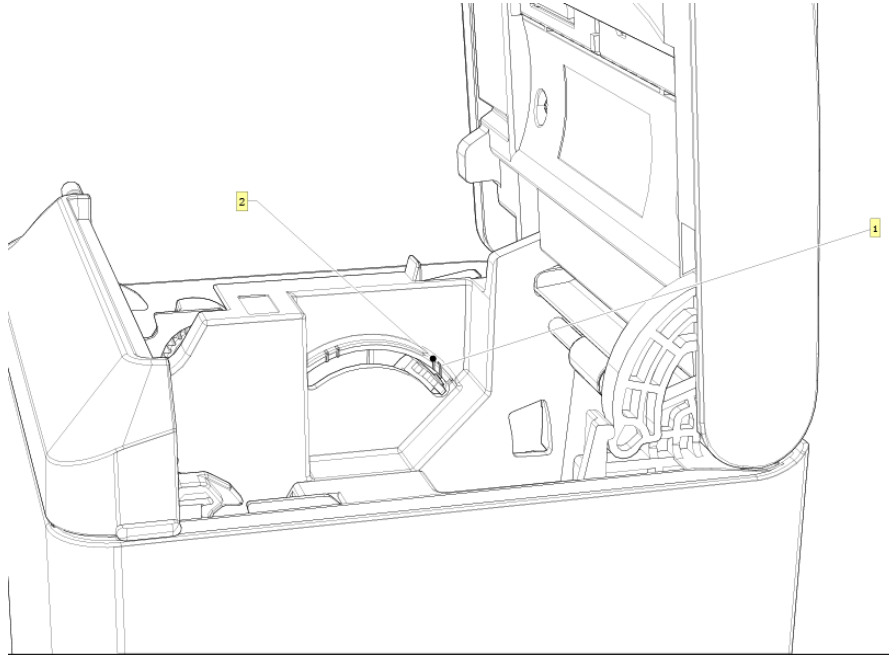

Fig. 4.5-1 Schematic drawing of paper near end position adjustment (output paper from the front)

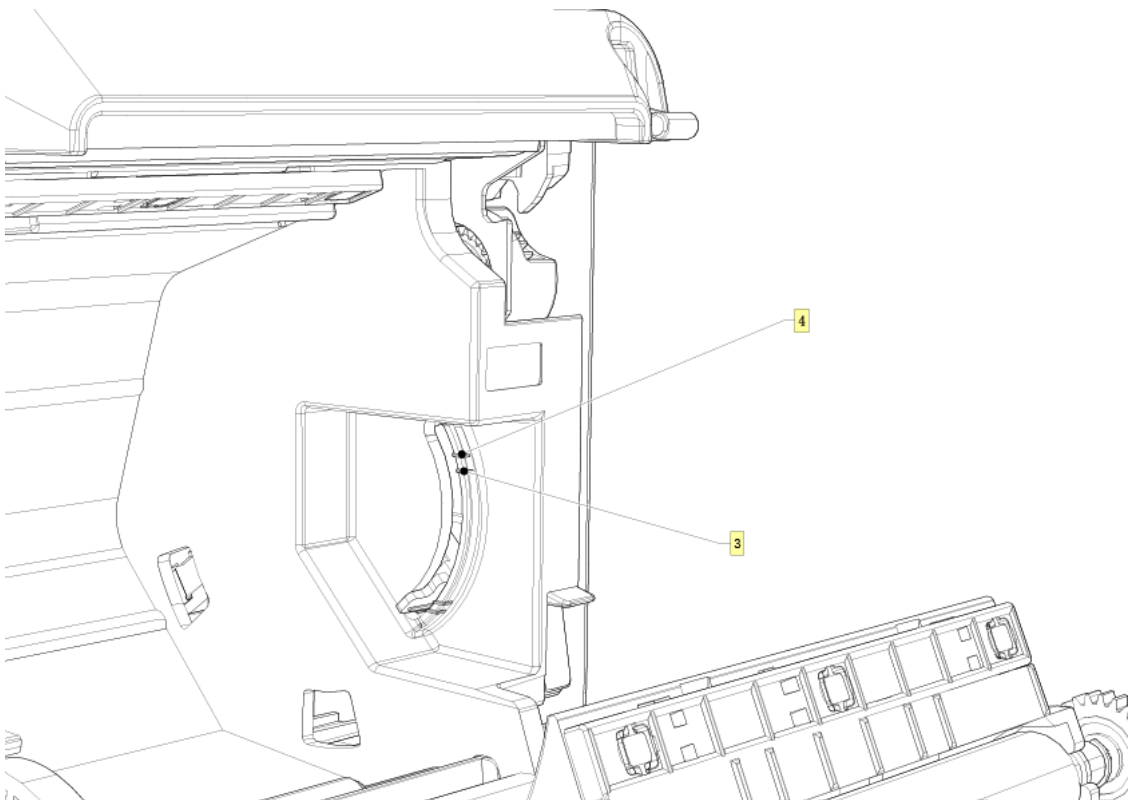
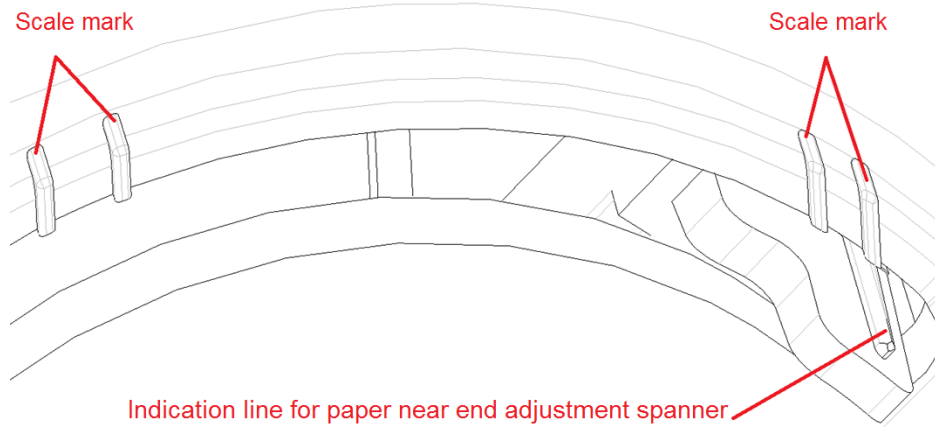

Fig. 4.5-2 Schematic drawing of paper near end position adjustment (output paper from the front)



The following diameter of core shaft of paper roll supported by the printer are as following: OD of 16.2mm core shaft and OD of 20.8 mm core shaft; adjust the paper near end sensor to adjust the application method and paper near end alarm function for core shaft with different outer diameters. There are four positions indicated by the scale marks for paper near end alarm, and users can rotate the paper near end adjustment spanner to make the indication line locate at different position, which change the paper near end alarm functions under different application conditions. The position 1 and 2 are for the application that output paper from the top, position 1 is for 16.2 mm core shaft of paper roll and position 2 is for 20.8 mm core shaft of paper roll. The position 3 and 4 are for the application that output paper from the front, position 3 is for 20.8 mm core shaft of paper roll and position 4 is for 16.2 mm core shaft of paper roll.

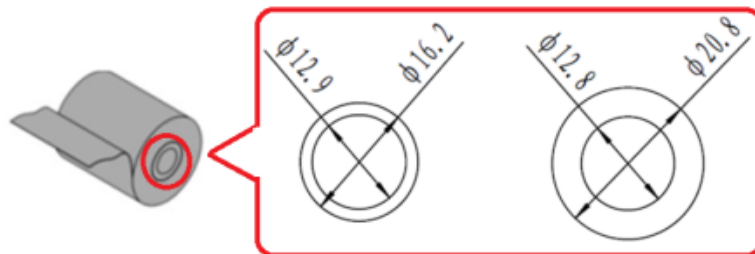

Fig. 4.5-3 core shaft of paper roll

4.6 Power-on and self-test

4.6.1 Power-on

- 1) Ensure that the printer is connected to power;
- 2) Turn on the power switch to power on the printer.

4.6.2 Print self-test page

- 1) Ensure that the printer is connected to power, and that paper roll is installed;
- 2) Ensure that the power LED is off and the printer is under power-off condition.
- 3) Press the feed button while turning on the printer power, and then release the button. The printer will print out configuration information and prompt characters "Press and Release FEED key to print characters" and "Press and Hold FEED key to config the printer". Then the printer enters pause status, and the error LED flashes;

4) Pressing the feed button momentarily, the printer will print out a character test sample, and the printing of self-test page is completed. Pressing the feed button for a long time, the printer will enter button configuration mode.

4.7 Hexadecimal dumping function

After entering Hexadecimal dumping mode, the printer will print out the data transmitted from the host computer in hexadecimal and their corresponding ASCII characters.

The sample printed under Hexadecimal dumping mode is as follows:

```

Hexadecimal Dump
To terminate hexadecimal dump,
press FEED button three times.

1B 21 00 1B 26 02 40 40 1B 69      . ! . . & . @ . i
1B 25 01 1B 63 34 00 1B 30 31      . % . . c 4 . . 0 1
41 42 43 44 45 46 47 48 49 4A      A B C D E F G H I J

*** completed ***
    
```

Fig. 4.7-1 Print sample under Hexadecimal dumping mode

Using Hexadecimal dumping mode:

- 1) Entering Hexadecimal dumping mode in the following ways:
 - a. Open the printer mechanism and turn on the printer while pressing the feed button. Release the button after the printer alarms (LED flashes and buzzer beeps).
 - b. Send command "GS (A".
- 2) The printer first prints "Hexadecimal Dump To terminate", and then prints the data transmitted from the host in hexadecimal and their corresponding ASCII characters.
- 3) Exiting from Hexadecimal dumping mode in the following ways:
 - a. Turn off the power, and then restart the printer.
 - b. Press the feed button three times.

⚠ Caution:

- ✧ If the hexadecimal data has no corresponding ASCII characters, the printer will print ".";
- ✧ Under Hexadecimal dumping mode, only commands DLE EOT, DLE ENQ, or DLE DC4 are valid.
- ✧ The data of the last character line can be printed by pressing down the feed button.

5 Routine maintenance

⚠ Caution:

- ✧ Before starting routine maintenance, ensure that the printer power is turned off.
- ✧ Do not use organic solvents like gasoline or acetone.
- ✧ When cleaning sensors, do not turn on the printer power until the pure alcohol has completely evaporated.
- ✧ It is recommended that the maintenance cycle should not be longer than one month.

5.1 Cleaning the print head and the platen roller

Follow the steps below to clean the print head and the platen roller:

- 1) Turn off the printer and open the top cover;
- 2) If the printing was just finished, please wait for the print head to cool down completely;
- 3) Wipe off the dust and stains on the surface of print head and platen roller with alcohol cotton (it should be wrung out);
- 4) After the alcohol is completely evaporated, close the top cover.

5.2 Cleaning the mark sensor

When the printer cannot identify the mark effectively, the mark sensor should be cleaned.

The cleaning steps are as follows:

- 1) Turn off the printer;
- 2) Press the cover open lever to open the top cover;
- 3) Wipe off the dust and stains on the surface of the sensor with soft cotton cloth dipped with pure alcohol (it should be wrung out);
- 4) Install the sensor cover after the pure alcohol is completely evaporated, then close the top cover and finish mark sensor cleaning.

5.3 Clearing the jammed paper and the cutter error

Steps for clearing jammed paper and cutter error are as follows:

Method 1:

- 1) Turn off the printer power and turn the spanner to open the top cover;
- 2) Clear the jammed paper, and then close the top cover;
- 3) Turn on the printer power again, and then the cutter can be reset automatically.

Method 2:

- 1) Turn off the printer power, disassemble the cutter cover in the direction shown in the figure, and turn the spanner to open the top cover;;
- 2) Clear the jammed paper, close the paper cabinet and turn on the printer power again, and then the cutter can be reset automatically.
- 3) Install the cutter cover.

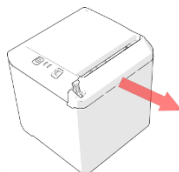

6 Interface signal

6.1 Serial interface

The serial interface of the printer is compatible with RS-232 standard, and its interface socket is D-SUB25 socket.

Pin	Signal	Signal definition	Function
1	FG	—	House ground
2	TXD	Output	Data output
3	RXD	Input	Data input
5	NC	—	Not connected
6	DSR	Input	Data device is ready
7	SG	—	Signal ground
8–19	NC	—	Not connected
4,20	DTR	Output	Require to send
21–25	NC	—	Not connected

Fig. 6.1-1 Serial interface definition

User can query interface setting status via printing configuration sample. The default settings of serial interface are as follows:

Baud rate: 115200bps; Data bits: 8; Parity: none; Stop bit: 1; Handshake: DTR/DSR.

6.2 Parallel interface

The parallel interface can work in IEEE 1284 compatible mode or nibble mode. The interface is 36PIN socket.

Interface definition:

Pin No.	Signal source	Signal definition
1	H	nStrobe
2	H	Data 0 (Least Significant Bit)
3	H	Data 1
4	H	Data 2
5	H	Data 3
6	H	Data 4
7	H	Data 5
8	H	Data 6
9	H	Data 7 (Most Significant Bit)
10	P	nAck
11	P	Busy
12	P	Perror
13	P	Select
14	H	nAutoFd
15		Not defined
16		Logic Gnd
17		Chassis Gnd
18	P	Peripheral Logic High
19		Signal Ground (nStrobe)
20		Signal Ground (Data 1)

21		Signal Ground (Data 2)
22		Signal Ground (Data 3)
23		Signal Ground (Data 4)
24		Signal Ground (Data 5)
25		Signal Ground (Data 6)
26		Signal Ground (Data 7)
27		Signal Ground (Data 8)
28		Signal Ground (PErrror, Select, and nAck)
29		Signal Ground (Busy and nFault)
30		Signal Ground (nAutoFd, nSelctIn, and nInIt)
31	H	nInIt
32	P	nFault
33		Not defined
34		Not defined
35		Not defined
36	H	nSelectIn
36	H	nSelectIn

- ✧ H stands for the host and P stands for the printer;
- ✧ The letter “n” in front of signal name indicates that the low level is effective;
- ✧ In data transmission, the host should not ignore “Busy” signal; otherwise print data may be missing;
- ✧ If the host cannot provide all the signal lines listed in the table above, the communication may fail;
- ✧ Parallel interface signal adopts TTL level; the rise and fall time of the signal from the host must be controlled within 0.5μs when it is used;
- ✧ For the interface, the signal line should use twisted pair with feeder line end, with the feeder line end connected to signal ground;
- ✧ The parallel interface connecting wire should be as short as possible on condition that it meets the use condition.

6.3 USB interface

1) Parameters

Data transmission: Support USB 2.0 full speed protocol.

Connector (Printer end): USB B type socket. Support USB HUB.

2) Interface signal definition and function

Pin No.	Signal name	Description
1	VBUS	Power
2	DATA-	Data minus
3	DATA+	Data plus
4	GND	Ground

Table 6.3-1 USB interface definition

3) Interface connector

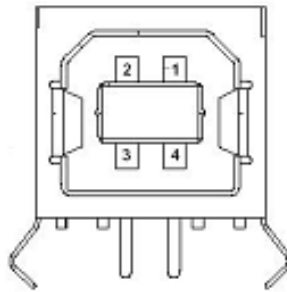

Fig. 6.2-1 USB interface connector

4) Mode

USB interface can work under API mode and Windriver mode. API mode is the manufacturer self-defined mode, and the user needs to install the USB driver provided by the manufacturer. Windriver mode is also called class mode, it is no need to install drivers and the user can use Microsoft's generic driver. The factory setting of printer is API mode, the user needs to adjust it to class mode if the printer is going to work under a Linux system.

6.4 Ethernet interface

1) Interface features

- Support 10/100 BASE-T communication standard
- Compatible with Ethernet II standard frame type
- LED shows network connection status and data transmission status
- Support 9100 port print
- Support status back
- Support parameter configuration
- Support firmware on-line upgrade
- Support printer status query and interface module maintenance based on HTTP

2) Interface signal definition

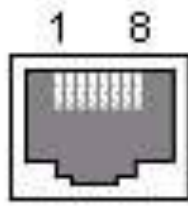

Fig.6.4-1 Ethernet interface

Interface adopts 10/100 BASE-T standard which complies with IEEE 802.3. The interface signal is defined as below:

Pin No.	Signal name	Description
1	TX+	Data transmission +
2	TX-	Data transmission -
3	RX+	Data receiving +
4	NC	Not connected
5	NC	Not connected
6	RX-	Data receiving -
7	NC	Not connected
8	NC	Not connected

Table 6.4-1 Ethernet interface definition

6.5 Double communication interface

Double communication interface support serial interface and Ethernet interface at the same time.

1) The serial interface of the printer is compatible with RS-232 standard, and its interface socket is DSUB-9 socket. Pin definition is as following

PIN No.	Signal definition
PIN1	Not connected
PIN2	RXD
PIN 3	TXD
PIN 4	DTR
PIN 5	SG
PIN6	DSR
PIN 7	RTS
PIN 8	CTS
PIN 9	Not connected

2) Ethernet interface

Details refer to section “6.4 Ethernet interface”.

6.6 Power interface definition

1) Power interface signal definition (100-240V AC):

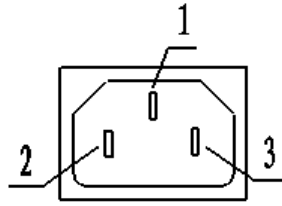

Fig.6.4-1 Schematic drawing of power interface

Pin No.	Signal name
1	E
2	L
3	N

Table 6.6-1 Power interface definition

2) Main control board power interface definition (24V DC):

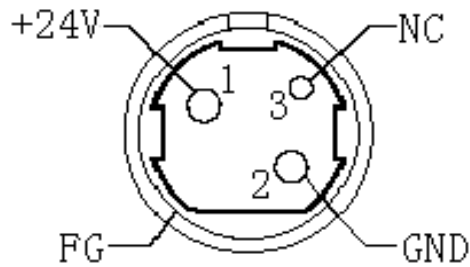

Fig.6.6-2 Schematic drawing of 24V power interface

6.7 Cash drawer interface signal definition

1) Electrical features

- Driving voltage: DC 24 V
- Driving current: Max. 1 A
- Cash drawer status detection signal: "L" = 0~0.5 V "H" = 3.3 V

2) Cash drawer interface socket uses RJ-11 6P connector



Fig.6.7-1 Schematic drawing of cash drawer interface

3) Interface signal definition

No.	Signal	Functions
1	FG	Frame Ground
2	DRAWER 1	Cash drawer 1 driving signal
3	DRSW	Cash drawer status detection signal
4	VDR	Cash drawer driving power
5	DRAWER 2	Cash drawer 2 driving signal
6	GND	Circuit share ground

Table 6.7-1 Cash drawer interface definition

 **Caution:**

- ✧ Do not connect or disconnect communication cable plug when the printer is powered on;
- ✧ Communication cable should be far away from strong current;
- ✧ Communication cable should adopt shielded cable.

7 Troubleshooting

When the printer has any problem, refer to this chapter for solution.

If the problem still cannot be solved, please contact your local dealer or manufacturer for assistance.

7.1 Printer doesn't work

Problem	Possible causes	Solution
LED is off and the printer doesn't work.	Printer is not connected to power supply.	Connect the printer to power supply.
	Printer power is off.	Turn on the printer power.
	Circuit board is damaged.	Contact your local dealer or manufacturer.

Table 7.1-1 Troubleshooting of printer not working

7.2 Error LED and buzzer alarm

Problem	Possible causes	Solution
Error LED flashes or buzzer beeps.	Paper end	Replace paper roll.
	Cutter error	Clear cutter error.
	The top cover is open	Close the top cover.
	Print head is overheating.	Turn off printer power and wait for the print head to cool down.
Error LED is always on and buzzer keeps beeping.	The printer has serious malfunction.	Contact your local dealer or the manufacturer.

Table 7.2-1 Troubleshooting of error LED and buzzer alarm

7.3 Problems during printing

Problem	Possible causes	Solution
Paper cannot be sent out normally.	Paper jam	Open the top cover, check paper path and cutter, and clear paper jam.
Printer starts printing but stops suddenly during printing.	Paper jam	Open the top cover, check the cutter, and clear paper jam.
Paper is not cut off.	Paper jam	Open the top cover, check the cutter, and clear the jammed paper.
Printout is not clear or has stains.	Paper roll is not installed correctly.	Check whether the paper roll is installed correctly or not.
	Paper is out of specification.	Use the recommended thermal paper.
	Dirty print head or platen roller	Clean the print head or the platen roller.
	Print darkness is too low.	Increase the print darkness as needed.
Vertical print content is missing.	Dirty print head or platen roller	Clean the print head or the platen roller.
	Print head error	Contact your local dealer or manufacturer.

Table 7.3-1 Troubleshooting during printing

8 Power management

The power management of T-40 has four operation modes: Off, Standby, Active, Sleep.

Printer will enter standby mode after powering on the printer or completing printing task.

Printer will enter sleep mode if there is no printing task for 2 minutes in standby mode.

Printer will awake automatically and enter active mode when a printing task comes, and will enter standby mode again after completing the printing task.

9 DUMP mode

There are two methods to enter DUMP mode:

- 1) Command method: Send 1D 28 41 02 00 00 01
- 2) Manual mode: Open the top cover, press and hold the FEED button, and turn on the printer power, then close the paper cabinet and release the button after the ERROR LED flashes. Pay attention to keep paper in the paper cabinet.

The printer will print out the following contents after the above operation:

“Hexadecimal Dump”

“To terminate hexadecimal dump, press FEED button three times”

The printer already entered the DUMP mode at this moment.

Method to exit from the DUMP mode: continuously press the FEED button for three times, and the printer will print out the following contents:

“***completed***”

The printer already exited from the DUMP mode at this moment.

Appendix Button configuration

PARAMETERSETTINGBYFEEDBU				
TTON				
MAINMENU				
Exit	->1			
Print Self Test	->2			
Configuration	->3	CONFIGURATION		
Exit Without Save		->1		
		->2		
Communication		->3	Back To Last Menu	->1
USB Interface		->2		
		Back To Last Menu		->1
		WinDriver Mode		->2
		API Mode		->3
Serial Interface		->3		
Back To Last		->1		
		Baud Rates		->2
		BAUD RATES:115200bps		
		Back To Last Menu		->1
		9600bps		->2
		19200bps		->3
		38400bps		->4
		57600bps		->5

				4800bps	->6	
				2400bps	->7	
				1200bps	->8	
				115200bps	->9	
			Parity	->3	PARITY: NONE	
				Back To Last Menu	->1	
				None	->2	
				Odd	->3	
				Even	->4	
			Data Bits	->4	DATA BITS: 8 Bits	
				Back To Last Menu	->1	
				7Bits	->2	
				8Bits	->3	
			Stop Bit(s)	->5	STOP BITS: 1Bit	
				Back To Last Menu	->1	
				1 Bit	->2	
				2 Bits	->3	
			Handshaking	->6	HANDSHAKING: DTR/DSR	
				Back To Last Menu	->1	
				DTR/DSR	->2	
XON/XOFF	->3					

			Data Receive Error	->7	Data Error Setting: Ignored						
						Back To Last Menu	->1				
						Ignored	->2				
						Print '?'	->3				
			Rx Buff Size	->4	RX BUFFER SIZE:4K Bytes						
						Back To Last Menu			->1		
						4 kBytes			->2		
						45 Bytes			->3		
			64 KBytes	->4							
				Mechanism & Hardware		HARDWARE SETTINGS					
Back To Last Menu	->1										
Mark Sensor	->2	MARK SENSOR: Disable									
						Back To Last Menu	->1				
						Enable	->2				
						Disable	->3				
Cutter	->3	CUTTER:									
						Back To Last Menu	->1				
						Cut Mode Settings	->2			CUTMODESETTINGS: Default Cut Mode	
											Back To Last Menu
Enable	->2										
Disable	->3										

				Full Cut Mode	->4
				Partial Cut Mode	->5
				Default Cut Mode	->6
			Auto Cut Settings	->3	AUTOCUT SETTINGS: Nouse this function
				Back To Last Menu	->1
				Cut paper when cover is closed	->2
				No cut paper when Cover is closed	->3
				Cut paper when Power on	->4
				No cut paper when Power on	->5
				Disable	->6
		Buzzer	->4	BUZZER: Enabled	
				Back To Last Menu	->1
				Enable	->2
				Disable	->3
	Print Settings	->5	PRINT SETTINGS		
			Back To Last Menu	->1	
			Darkness Settings	->2	DARKNESS SETTING:
				Back To Last Menu	->1
				Low	->2
				Normal	->3
				High	->4

			Extra High	->5	
		Paper Roll Width	->3	PAPER ROLL WIDTH: 80.0 mm	
			Back To Last Menu	->1	
			57.5 mm	->2	
			80.0 mm	->3	
			82.5 mm	->4	
		Left Margin	->4	LEFT MARGIN: 7 mm	
			Back To Last Menu	->1	
			0 mm	->2	
			1 mm	->3	
			3 mm	->4	
			5 mm	->5	
			7 mm	->6	
			9 mm	->7	
		Right Margin	->5	Right margin: 9 mm	
			Back To Last Menu	->1	
			0 mm	->2	
			1 mm	->3	
			3 mm	->4	
			5 mm	->5	
			7 mm	->6	

			9 mm	->7	
		CR Command	->6	CR COMMAND: Disable	
				Back To Last Menu	->1
				Enable	->2
				Disable	->3
		Code Page	->7	Code page settings	
				Back To Last Menu	->1
				Print All	->2
				Code pages	
				Select A	->3
				Code page	
		Save Paper Level	->8	SAVE PAPER LEVEL	
				Back To Last Menu	->1
				Disable	->2
				25%	->3
				50%	->4
				75%	->5
				100%	->6
	Paper Sensor Settings	->6	PAPER NEAR END		
				Back To Last Menu	->1
				Paper Low Alarm	->2
				Paper low alarm: Enable	
				Back To Last Menu	->1
				Enable	->2

			Disable	->3	
		Stop Print When PAPER Low	->3	STOP PRINT WHEN PAPERLOW: Disable	
			Back To Last Menu	->1	
			Enable	->2	
			Disable	->3	
		Paper Near End Sensor	->4	PAPER NEAR END SENSER: Enabled	
			Back To Last Menu	->1	
			Enable	->2	
			Disable	->3	
	Set Default Config	->7	SET DEFAULT CONFIGURATION		
			Back To Last Menu	->1	
			Set Printer To Default	->2	
	FONTA/ FONTB Settings	->8	Current Font: FONTA		
			Back To Last Menu	->1	
			Select FONT A	->2	
			Select FONT B	->3	
			Select UD FONT A	->4	
			Select UD FONT B	->5	
	Beep settings	->9	Beep settings: Disabled		
			Back To Last Menu	->1	
			Enable External Herald	->2	

		Enable Internal buzzer	->3	BEEP MODE			
						Back To Last Menu	->1
						Mode 1	->2
						Mode 2	->3
						Mode 3	->4
						Mode 4	->5
						Mode 5	->6
		All Beep disabled	->4				
		Test Page Settings	->10	Testpage up to down print: Disabled			
						Back To Last Menu	->1
Enable	->2						
Disable	->3						
Enter code,then hold Button Down							
Sensor Test	->4	Sensor Test Mode: ERROR LED state will change according to sensorstate To EXIT, hold button down at least 1second					
Print NV Bitmap	->5						
Cutter Test	->6						
Print Statistics	->7	T-40 STATISTICS					
		CUT	:0				
		TCUT	:0				
		LFS					
		TLFS					

		ONTIME	:0			
E05Configuration	->8	E05CONFIGURATION				
		Reset JK-E04 Config	->1			
		Print Settings	->2	IP Address: MAC Address: Subnet Mask: GATEWAY: Print Port:		