



Questo manuale d'istruzione è fornito da trovaprezzi.it. Scopri tutte le offerte per [Pioneer VM-80](#) o cerca il tuo prodotto tra le [migliori offerte di Diffusori Audio](#)



Questo manuale d'istruzione è fornito da trovaprezzi.it. Scopri tutte le offerte per [Pioneer VM-80](#) o cerca il tuo prodotto tra le [migliori offerte di Diffusori Audio](#)

Instruction manual

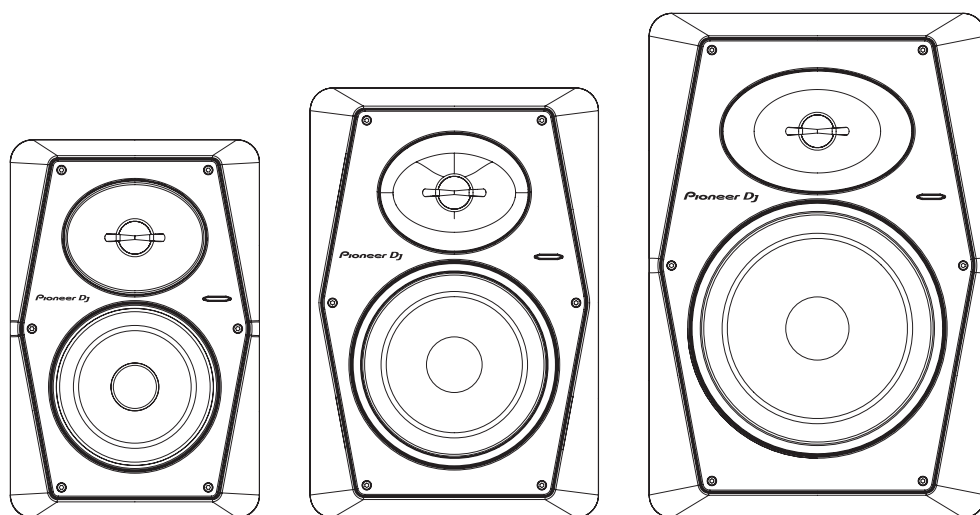

VM-50 / VM-50-W / VM-70 / VM-80

Active Monitor Speaker

pioneerdj.com/support/

For FAQs and other support information for this product, visit the above site.

Pioneer Dj

Introduction

Main Features

- “Vortex bass accelerator” structure to achieve a fast response rich bass sound.
 - Constant directivity Horn to achieve powerful medium and high range sound and broad uniform listening space.
 - Rigid aluminum front baffle to reduce unwanted vibrations.
 - Class D amplifier with 96 kHz sampling to enable wide bandwidth sound reproduction.
 - “DSP control” to enable 16-band adjustment in accordance with the use, room acoustic properties, and preferences.
-
-

Confirm All Accessories

- Power cord × 1
- Bottom cushion x 1 (4pcs/1 sheet)
- Precautions for Use × 1
- Instruction Manual (this document)
- Warranty (for some regions) *

* Only products in Europe.

The contents of the warranty for the United States and Canada are provided on the last pages of the instructions in English and French.

Names and Functions of Parts

Front Panel Facilities

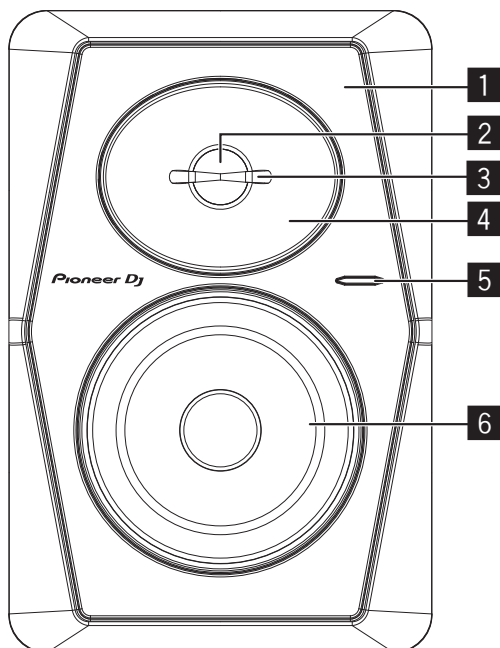

- 1 Aluminum front baffle**
Reduces unwanted vibrations.
- 2 1-inch high-resolution soft dome tweeter**
- 3 Tweeter protective guard**
- 4 Constant directivity Horn**
Achieves uniform listening space.
- 5 POWER/STANDBY indicator**
Lights up in white when turning the power supply on. During standby it is lit in red.
- 6 Aramid fiber woofer**
Light and extremely rigid cones provides the best bass response.

Rear Panel Facilities

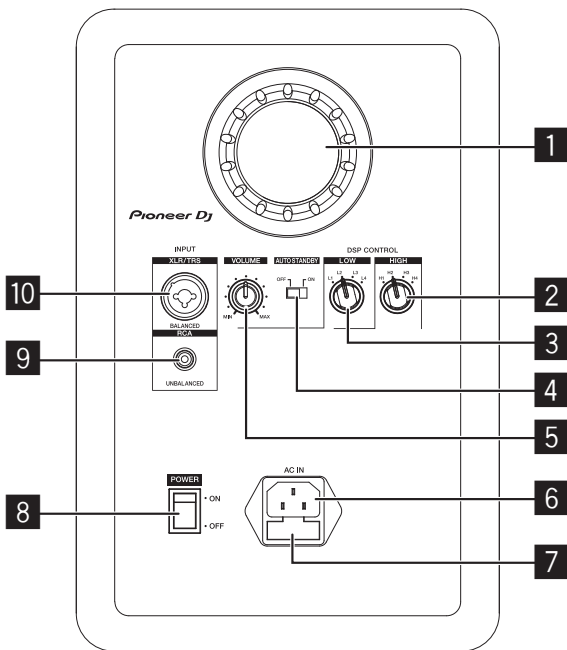

- 1 Bass-reflex duct**
"Vortex bass accelerator" structure of the bass-reflex duct to achieve high-speed deep bass reproduction.
- 2 Switch for switching HIGH EQ**
Use to switch between four types of EQ setting: ROOM 1, FLAT, ROOM 2, and BRIGHT TREBLE. For details see "DSP CONTROL" on page 4.
- 3 Switch for switching LOW EQ**
Use to switch between four types of EQ setting: ROOM 1, FLAT, ROOM 2, and CLUB BASS. For details see "DSP CONTROL" on page 4.
- 4 AUTO STANDBY switch**
Use to turn the auto standby function on or off.
When the auto standby function is turned on, the speakers automatically enter standby mode if no input signal is received for a certain period of time (approximately 25 minutes) and power consumption can be reduced. When an input signal is received while the speakers are in standby mode, the speakers will automatically resume from standby mode.
 - The POWER indicator on the front panel is lit in red during standby mode.
 - When the input signal is weaker than a certain level, the speakers may not automatically resume from standby mode. In such cases, turn off the [AUTO STANDBY] switch to use the speakers.
 - To force the speakers to resume from standby mode, turn off the [POWER] switch on the rear panel once, and turn it back on after a few seconds.
- 5 VOLUME dial**
Use to adjust the sound level (volume).
- 6 AC IN**
Connect the accessory power cord here and to an AC power outlet. Do not plug in the power cord until all other connections have been completed. Use only the furnished accessory power cord.
- 7 Fuse holder**
- 8 POWER switch**
Use to turn the power on and off.
- 9 RCA INPUT jack**
RCA pin-type unbalanced input jacks.
- 10 XLR/TRS INPUT jack**
Both XLR jack (balanced) and 1/4" TRS (balanced type PHONO) are supported. The XLR jack arrangement is Pin 1 Ground, Pin 2 Hot, and Pin 3 Cold.

DSP CONTROL

This unit has a function for adjusting the frequency characteristics in accordance with the installation location or environment. Carry out the adjustment using a combination of the two dials on the rear panel. At the time of shipment from the factory it is set so that flat properties can be obtained in an anechoic chamber, so perform the adjustment to suit the installation environment.

LOW EQ

Use this for adjusting the bass, in accordance with the installation location and purpose of use.

- L1: ROOM 1
Tone quality with bass minimized. This is effective when installed near walls, etc., and the volume of the bass is too loud, or when you do not want the bass reverberating at night time.
- L2: FLAT
Flat frequency characteristics that faithfully reproduces the input sound.
- L3: ROOM 2
Tone quality with high bass volume. This is effective when the reverberation in a room is too small and the bass is insufficient.
- L4: CLUB BASS
Bass with extra punch, for a club-like sound. This is effective when the bass is insufficient.

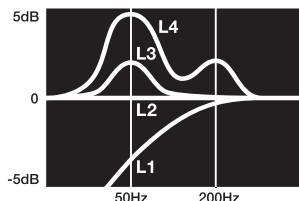

HIGH EQ

Use this for adjusting the treble, in accordance with the installation location and purpose of use.

- H1: ROOM 1
Tone quality with treble minimized a certain amount. This is effective when used in a room where the volume of the treble is too loud during a live event.
- H2: FLAT
Flat frequency characteristics that faithfully reproduces the input sound.
- H3: ROOM 2
Sound with high treble volume with the image of bright wide spaces. This is effective when the treble is insufficient.
- H4: BRIGHT TREBLE
The sound of the musical instruments can be clearly heard. For example the outlines of the sound of guitars, cymbals, trumpets, etc., are clear.

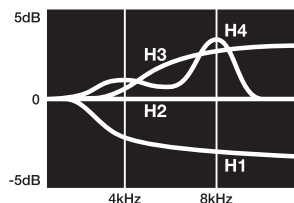

Installation and Connections

How to Install

A speaker's playback sound is delicately influenced by conditions in the listening room. To produce optimum listening conditions, take due consideration of the conditions of your installation location before beginning actual installation.

- Place the speakers at ear level.

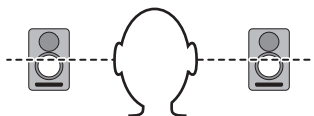

- For a natural stereo effect, the right and left speakers should be installed in symmetrical and equidistant positions from the listening position.
- To prevent sliding, apply the furnished cushions to the bottom of the main unit.

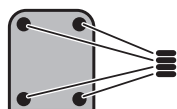

WARNING

Store small parts out of the reach of children and infants. If accidentally swallowed, contact a doctor immediately.

D41-6-4_A1_En

- Speakers should ideally be located at 30° angles from the listening position (together forming a total 60° angle), and rotated inward to face the listening position.

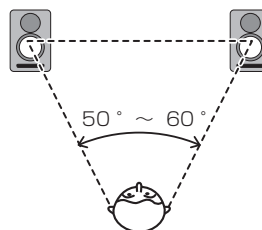

VENTILATION CAUTION

When installing this unit, make sure to leave space around the unit for ventilation to improve heat radiation (at least 15 cm at top, 15 cm at rear, and 15 cm at each side).

WARNING

Slots and openings in the cabinet are provided for ventilation to ensure reliable operation of the product, and to protect it from overheating. To prevent fire hazard, the openings should never be blocked or covered with items (such as newspapers, table-cloths, curtains) or by operating the equipment on thick carpet or a bed.

D3-4-2-1-7b*_A1_En

Connections

- When making or changing connections, always turn off the power and disconnect the power cord from its outlet.
- Also, be sure to read the operating instructions for the other components to which you are connecting these speakers.
- Do not plug in the power cord until all other connections have been completed.
- Use only the furnished accessory power cord.
- Make sure to set the sound level at an appropriate level as the input signals to the XLR INPUT connector (or TRS INPUT jack) and RCA INPUT jack will be mixed together, affecting the sound level.

Additional Information

Troubleshooting

- Check the following items when you think there is a problem. Also, check the equipment connected to the unit. If it is still not operating properly, contact your dealer.
- On occasion, the unit may fail to operate properly due to static electricity or other external conditions. In this event, disconnect the power cord and wait for five minutes or more, then reconnect the power cord and check for proper operation.

Symptom	Items to Check	Remedy
No power	Is power cord connected properly?	Connect power cord to outlet.
No sound from connected audio devices, or sound is very small.	Has connected audio device been set properly?	Set device's external input and sound volume properly.
	Is connection cable connected properly?	Connect cables properly.
	Are connectors or plugs dirty?	Clean connectors and plugs before connecting.
	Is the sound volume set properly?	Turn the [VOLUME] dial on the rear panel clockwise and turn up the volume.
	Is the power turned on?	Turn on the [POWER] switch on the rear panel.
The POWER indicator (white) does not light.	Is the auto standby function on?	Turn off the [POWER] switch on the rear panel once, wait a few seconds, and then turn it back on.
	Is the power turned on?	Turn on the [POWER] switch on the rear panel.
Speakers do not resume (turn on) from standby mode.	Is the auto standby function on?	Turn off the [POWER] switch on the rear panel once, wait a few seconds, and then turn it back on.
	Is the level of the input signal low?	Increase the level of the input signal. Turn off the [AUTO STANDBY] switch on the rear panel and turn off the auto standby function.
Sound is distorted.	Is the sound volume set properly?	Slowly turn the [VOLUME] dial on the rear panel counterclockwise and turn down the volume.
	Is the output level of the connected audio device set properly?	Adjust the output level of the connected audio device properly.
Feedback (continuous howling sound)	Is the sound volume set properly?	Slowly turn the [VOLUME] dial on the rear panel counterclockwise and turn down the volume.

Trademarks and Registered Trademarks

- "Pioneer DJ" is a trademark of Pioneer Corporation, and is used under license.
- Other listed company names and a product name are the registered trademark of the companies or trademarks.

Specifications

	VM-50/VM-50-W	VM-70	VM-80
Type	Bi-amp 2-way active speaker		
Amplifier			
Amplifier type	Class D with DSP		
LF amplifier	30 W (4 Ω)	70 W (4 Ω)	90 W (4 Ω)
HF amplifier	30 W (4 Ω)	30 W (4 Ω)	30 W (4 Ω)
Input connectors (balanced input)	XLR/TRS combo × 1		
Input connectors (unbalanced input)	RCA × 1		
Input impedance	10 kΩ		
Speaker			
Enclosure	Bass reflex		
Enclosure material	MDF vinyl laminate		
Woofers (LF driver)	5.25" (133 mm) cones	6.5" (165 mm) cones	8" (203 mm) cones
Tweeter (HF driver)	1" (25 mm) soft dome		
Reproduction frequency band	40 Hz – 36 kHz	37 Hz – 36 kHz	34 Hz – 36 kHz
Power unit/other			
Supported voltages	AC 110 V – 240 V, 50 Hz/60 Hz		
Power consumption	30 W	45 W	60 W
Power consumption during standby mode	0.3 W or less		
External dimensions (W × H × D)	198 × 300 × 265 mm	229 × 341 × 312 mm	267 × 400 × 325 mm
Weight	5.5 kg	7.7 kg	9.7 kg

The specifications and design of this product are subject to change without notice.

© 2020 AlphaTheta Corporation. All rights reserved.

AlphaTheta Corporation

6F, Yokohama i-Mark Place, 4-4-5 Minatomirai, Nishi-ku, Yokohama, Kanagawa 220-0012 JAPAN

AlphaTheta株式会社

〒220-0012 神奈川県横浜市西区みなとみらい4丁目4番5号 横浜アイマークプレイス6階

Корпорация АльфаТета

6F, Йокогама i-Mark Place, 4-4-5 Минатомирай, Ниси-ку, Йокогама, Канагава 220-0012 ЯПОНИЯ

AlphaTheta EMEA Limited

Artemis Building, Odyssey Business Park, West End Road, South Ruislip, Middlesex, HA4 6QE, U.K. TEL: +44-203-7617-220

AlphaTheta Music Americas, Inc.

2050 W. 190th Street, Suite 109, Torrance, CA 90504, U.S.A. TEL: +1 (424) 488-0480

AT_001_all_01

<DRI1692-C>