



Questo manuale d'istruzione è fornito da trovaprezzi.it. Scopri tutte le offerte per [Pro-Ject T1](#) o cerca il tuo prodotto tra le [migliori offerte di Personal Audio e Hi-Fi](#)



Questo manuale d'istruzione è fornito da trovaprezzi.it. Scopri tutte le offerte per [Pro-Ject T1](#) o cerca il tuo prodotto tra le [migliori offerte di Personal Audio](#)



# INSTRUCTIONS FOR USE

## Pro-Ject T1 / T1 Phono SB / BT

Dear Music Lover,

Congratulations and thank you for choosing Pro-Ject Audio Systems record player.

Your T1 turntable has been handcrafted and rigorously tested by skilled technicians to give you years of enjoyable, trouble free service.

Please contact your dealer if you require additional assistance.

**Important:**

Your turntable was shipped partially disassembled in order to avoid damage to sensitive parts. Please check immediately to make sure that neither the packaging nor the device was damaged in transit. If you are missing parts or if the unit is damaged, please do not operate and contact your dealer.

Contents

|  |          |
|--|----------|
| Product illustrations                      | 4        |
| <u>General setup</u>                       |          |
| 1. Platter and drive belt installation     | 5        |
| 2. Cartridge installation, stylus exchange | 5        |
| 3. Vertical Tracking Force setting (VTF)   | 6        |
| 4. Maintenance and cleaning                | 7        |
| 5. Specific turntable informations         |          |
| <b>a) T1</b>                               | <b>7</b> |
| <b>b) T1 PHONO SB</b>                      | <b>8</b> |
| <b>c) T1 BT</b>                            | <b>9</b> |
| Technical parameters                       | 9        |
| Troubleshooting, warranty, service         | 10       |
| Exploded view of the packaging             | 11       |

Please do your part to help protect the environment:

Disposal of packaging material:

Pro-Ject packaging is carefully designed to protect your component from damage in transit and you are strongly urged to keep the original packaging in order to safely ship or otherwise transport your turntable in the future.

However, the packaging materials were chosen to be environmentally friendly, so if you must discard the packaging, please recycle.

# GENERAL INFORMATIONS

## Controls, features and connections

- 1 PLATTER & FELT MAT
- 2 CHASSIS
- 3 MOTOR WITH PULLEY
- 4 SUB – PLATTER
- 5 DRIVE BELT
- 6 TONEARM COUNTERWEIGHT
- 7 TONEARM LIFT LEVER
- 8 TONEARM REST / REMOVABLE TRANSPORT LOCK
- 9 TONEARM TUBE
- 10 HEADSHELL WITH FINGER LIFT AND PRE-MOUNTED ORTOFON CARTRIDGE
- 14 LID
- 13 LID HINGES
- 14 HINGE FASTENERS
- 15 POWER SUPPLY SOCKET

## Accessories

- 2 SINGLE ADAPTOR
- 4 ALLEN KEY 1,5mm
- 5 COUNTERWEIGHT no. 56
- 6 TWO-POINT CARTRIDGE ALIGNMENT PROTRACTOR
- 8 CONNECTION CABLE (CONNECT IT E RCA)
- 9 INSTRUCTION FOR USE

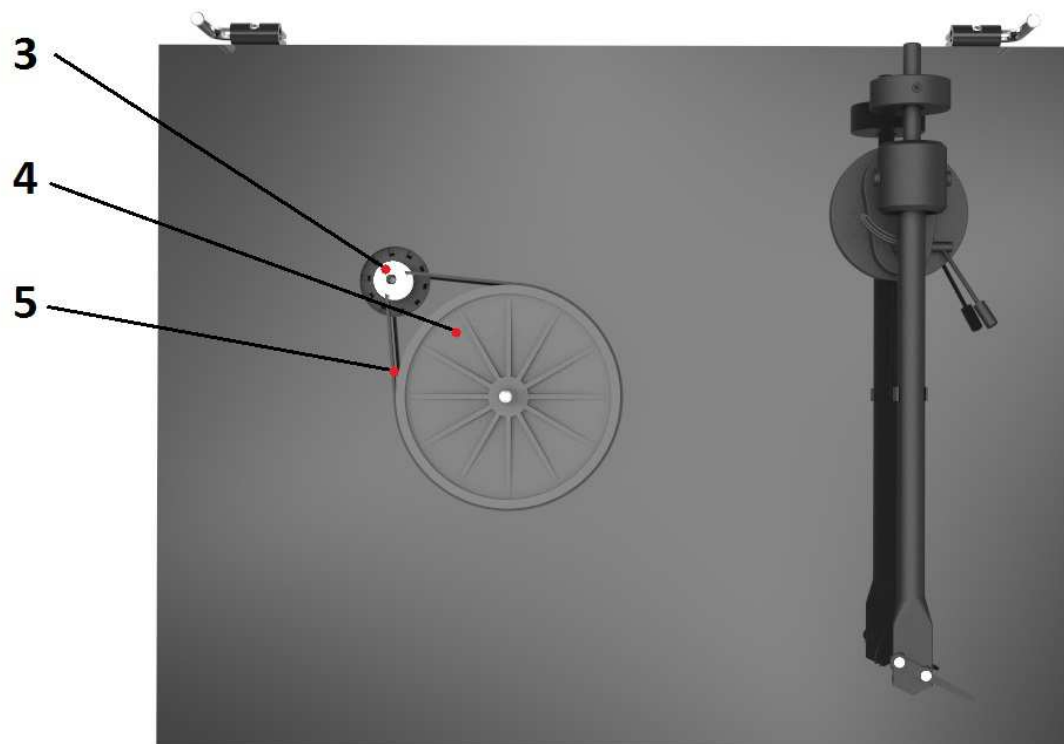
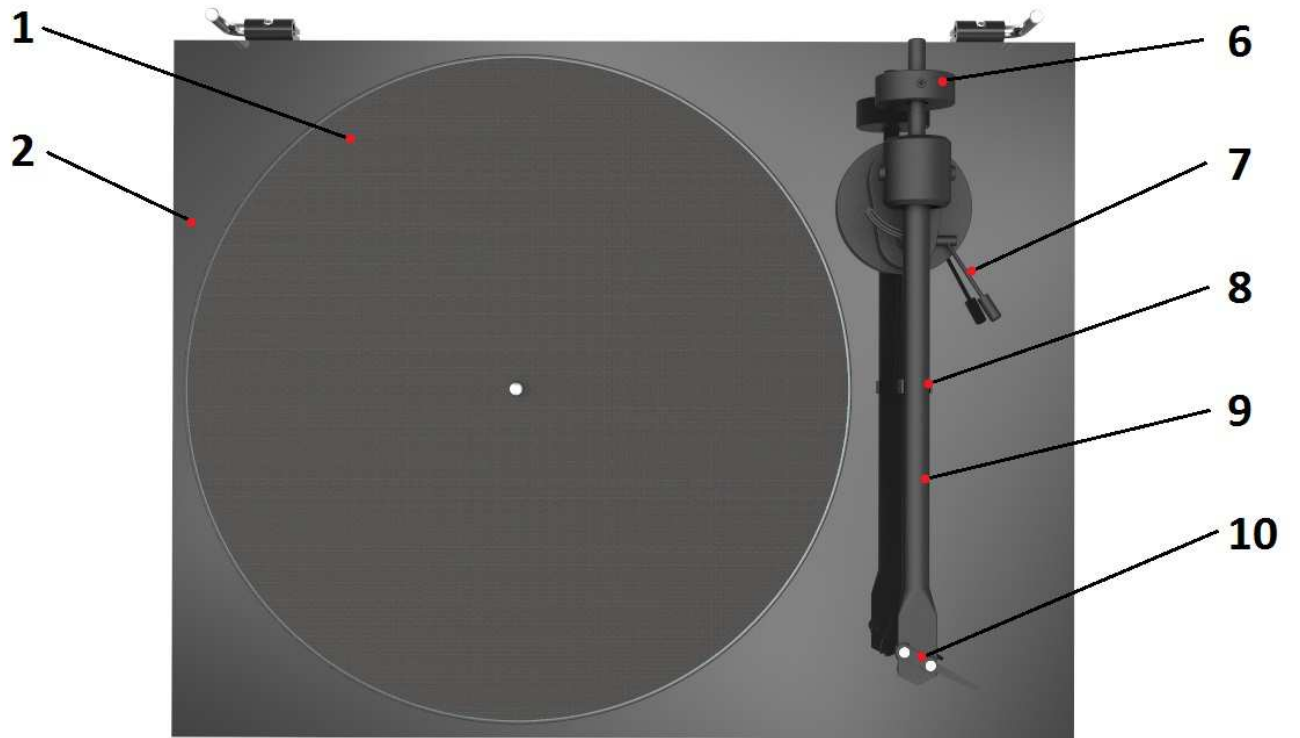

## **SETUP**

### **1. Platter and drive belt installation**

Please remove drive belt from accessories box and install it as shown in the following illustration. Put the felt mat on the top of the platter.

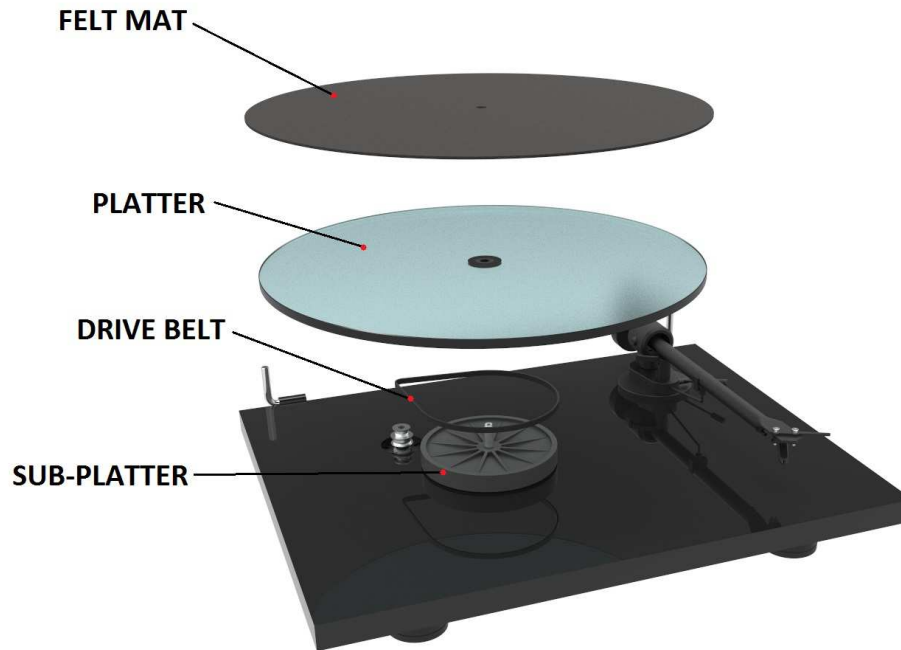

### **2. Cartridge installation, stylus exchange**

\* If you purchased this turntable in a package that included the cartridge, this has already been done for you.

Install the cartridge into the aluminium headshell, using the appropriate hardware included with your cartridge. All cartridges with half inch mounting holes can be fitted.

Connect the cartridge as indicated below:

- White left channel L+
- Red right channel R+
- Green right channel R-
- Blue left channel L-

For correct cartridge alignment, use the two-point cartridge alignment protractor provided with your T1 accessories. If unfamiliar with two-point setup, please refer to your dealer.

A damaged or worn stylus may harm your record collection and should be replaced.

Please remove stylus protection before pulling the stylus from the cartridge and replace for a new one. Stylus type is exchange for pre-mounted cartridge Ortofon OM 5e: Stylus OM 5e. If in doubt, consult your local dealer or distributor.

### 3. Vertical Tracking Force setting (VTF)

\* This setting is only necessary when you decided to replace your cartridge. For factory fitted cartridge, VTF was perfectly pre-set already.

Before setting the Vertical Tracking Force, confirm the exact weight of your cartridge.

Pushing carefully, move the counterweight onto the rear end of the counterweight support rod as shown in the illustration below. Place the stylus pressure gauge onto the platter. To set the required VTF, lower the tonearm lift lever as indicated in the illustration and place the tip of the stylus exactly in between the two points marked 15mN and 20mN.

If the stylus gauge becomes level, then the correct pressure has been achieved. However if there is insufficient or excessive pressure the gauge will either not move or tilt down.

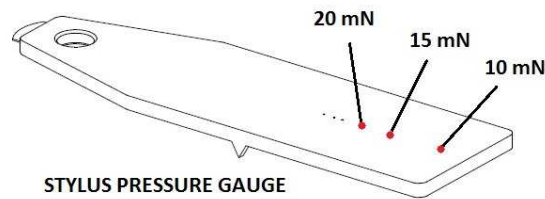

To adjust the amount of pressure, carefully move the counterweight (11) along the support rod, until the stylus pressure is sufficient to raise the pressure gauge to the level position. Moving the counterweight (6) away from the cartridge will reduce pressure and towards will increase pressure. Finally secure the counterweight (6) using hexagonal key provided.



### 4. Maintenance and cleaning

Your record player requires little or no regular maintenance. Remove dust with a slightly moistened antistatic cloth. Never use a dry cloth because this will create static electricity which attract more dust! Antistatic cleaning fluids are available at specialist stores but must be applied sparingly to avoid damage to rubber parts. It is recommended to fit the needle cover before cleaning or maintenance is carried out to avoid damage.

If the player is not used over a long period of time the drive belt can be removed to prevent unequal stretching.

Controls, features and connections

- 1 ON/OFF SWITCH
  - 2 DOUBLE STEP PULLEY
  - 3 OUTPUT CABLE CONNECT IT E
  - 4 DIRECT POWER CORD
- 

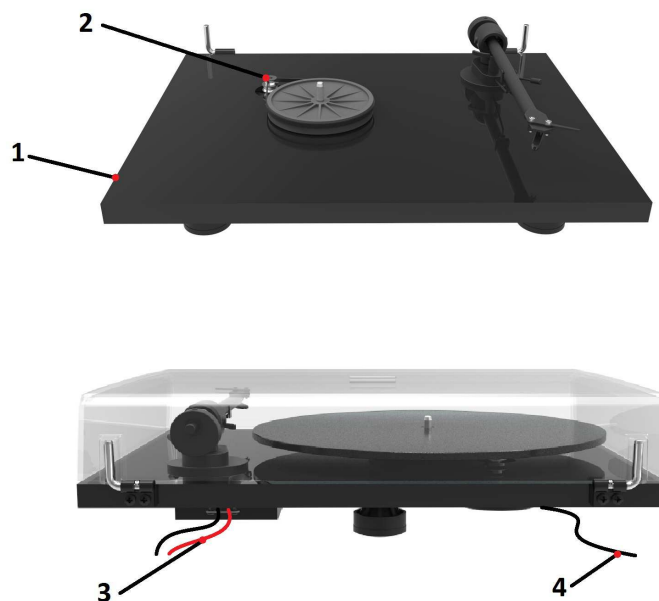
Switching on and off

Pressing the ON/OFF switch alternately starts or stops the motor.

Changing replay speed

To play 45 r.p.m., put the drive belt over the larger diameter part of the motor pulley. To revert to 33 r.p.m. repeat the proceedings using the smaller step on the pulley.

Connection to the amplifier

The record player has a captive tonearm signal lead for connection to the amplifier. Use the Phono input on your amplifier. Make sure that the phono input offers correct matching and amplification for the type of cartridge used. Line inputs (such as CD, Tuner, Tape or Video) are not suitable.

Take care to connect the left and right channels correctly. The right channel is usually marked red, the left channel black or white. Check the manual supplied with your amplifier for relevant information. The earthing wire of the tonearm lead should be connected to the earth terminal on your amplifier (if provided).

If your amplifier does not have an input suitable for phono cartridges you will require a separate phono amplifier stage for MM or MC cartridges which is then connected between the record player and a free line level input of the amplifier.

# T1 Phono SB

## SPECIFIC INFORMATIONS

### Controls, features and connections

|   |                |   |                                     |
|---|----------------|---|-------------------------------------|
| 1 | ON/OFF SWITCH  | 4 | PHONO/LINE OUTPUT, EARTH CONNECTION |
| 2 | MOTOR PULLEY   | 5 | PHONO/LINE OUTPUT SWITCH            |
| 3 | SPEED SELECTOR | 6 | POWER SUPPLY SOCKET                 |

---

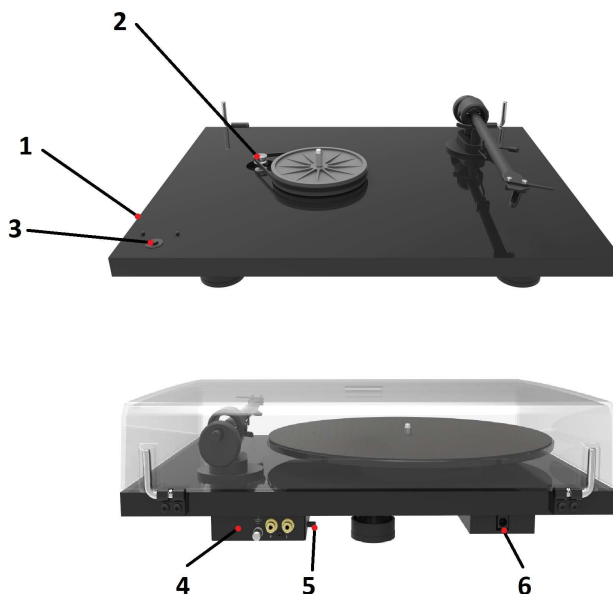

### Switching on and off, changing replay speed

Pressing the ON/OFF switch starts the motor of the turntable. Pressing the speed selector selects between 33 r.p.m. and 45 r.p.m. The selected speed is shown respectively by the flashing LED. When the platter has attained full speed, the LEDs stop flashing.

### Connection to the amplifier

The record player has gold plated female RCA phono sockets and possibility to choose between Phono and LINE output. With LINE OUT on, you can use a line input (such as AUX, CD, Tuner, Tape or Video) on your amplifier. With PHONO OUT on, you can use your own phono pre-amplifier (sometimes labelled gram, disc or RIAA).



Take care to connect the left and right channels correctly. The right channel is usually marked red, the left channel black or white. The earthing wire of the tonearm lead should be connected to the earth terminal on your amplifier (if provided).

Controls, features and connections

- 1 ON/OFF SWITCH
- 2 STEPPED DRIVE PULLEY
- 3 PHONO/LINE OUTPUT, EARTH CONNECTION
- 4 BLUETOOTH SWITCH

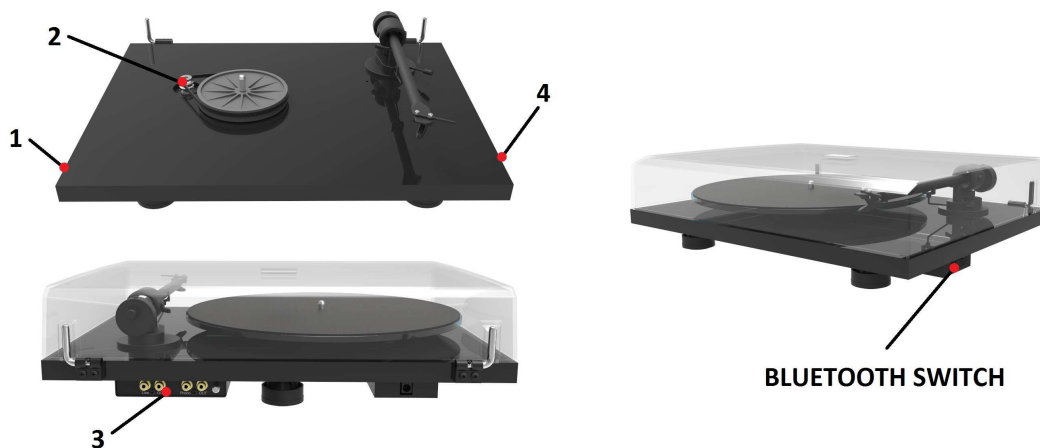
Switching on and off

Pressing the ON/OFF switch alternately starts or stops the motor.

Changing replay speed

To play 45 r.p.m., put the drive belt over the larger diameter part of the motor pulley. To revert to 33 r.p.m. repeat the proceedings using the smaller step on the pulley.

Connection to the amplifier

The record player has two possible outputs – Line OUT with integrated preamplifier and Phono OUT for connection to the preamplifier. If you choose Phono OUT, than use the Phono input (sometimes labelled gram, disc or RIAA) on your amplifier. Make sure that the phono input offers correct matching and amplification for the type of cartridge used. If you choose Line OUT, than use the Line inputs (like CD, Tuner, Tape or Video).

Take care about connecting the left and right channel correctly. The right channel is usually marked red, the left channel black or white. Check the manual of your amplifier for relevant information. An earthing wire may be connected to the screw terminal between the sockets if you encounter humming problems.

Bluetooth pairing

The record player has Bluetooth output and transmit signal automatically when is connected to mains.

It is paired automatically with any device with Bluetooth receiver (such as Pro-Ject MaiA, MaiA DS, Bluetooth Box s and Bluetooth Box E).

For pairing with other devices and portable speakers use the manual of the given product.

For restart of the Bluetooth transmitter, please turn OFF and ON the Bluetooth module by using the switch. Restart is needed only when there is a change of the Bluetooth receiver.

## Technical specifications Pro-Ject T1 / Pro-Ject 8.6

|                                  |                       |
|----------------------------------|-----------------------|
| Nominal speeds                   | 33/45 r.p.m.          |
| Speed variance                   | 33: ±0.70% 45: ±0.60% |
| Wow and flutter                  | 33: ±0.25% 45: ±0.23% |
| Signal to noise                  | -65dB                 |
| Effective tonearm mass           | 8.0g                  |
| Effective tonearm length         | 8.6" (218,5mm)        |
| Overhang                         | 22,0mm                |
| Power consumption                | 4,5W                  |
| Dimensions (W x H x D)           | 420 x 112 x 330mm     |
| Weight                           | 5,0kg                 |
| Dimensions packaging (W x H x D) | 488 x 235 x 393mm     |
| Weight incl. packaging           | 7,0kg                 |

## Technical specifications – Turntable power

|             |  |
|-------------|--|
| T1          | 230V / 120V, 50Hz 60Hz, direct power cord suitable for your country's mains supply (EU, UK, US, AUS) |
| T1 Phono SB | 15V/ 0,8 A DC, universal power supply  |
| T1 BT       | 15V/ 0,8 A DC, universal power supply  |

## Technical specifications MM-Cartridge Ortofon OM 5E

|                            |   |
|----------------------------|---|
| Frequency range            | 20-25.000Hz                             |
| Channel separation         | 22dB/1kHz                               |
| Output voltage             | 4mV                                     |
| Recommended load impedance | 47kohms/amplifier connection – MM-input |
| Compliance/stylus type     | 20µm/mN – elliptical                    |
| Recommended tracking force | 17,5mN                                  |
| Weight                     | 5g                                      |

## Technical specifications MM phono pre-amplifier

|                                  |                              |
|----------------------------------|------------------------------|
| Gain                             | 34dB                         |
| Output voltage typically         | 200mV/1kHz at 5mV/1kHz input |
| Input impedance                  | 47kohms/100pF                |
| Noise floor                      | -68dB                        |
| RIAA-equalisation curve accuracy | 20Hz-20kHz / max. 0,5dB      |

## Bluetooth

|  |  |
|--|--|
| Maximum transmit power per operated frequency band | Class II, 2.5mW (4dBm) per 2.4GHz – 2.48 GHz |
|--|--|

## Potential incorrect use and fault conditions

Pro-Ject turntables are manufactured to the highest standards and undergo strict quality controls before leaving the factory. Faults that may possibly occur are not necessarily due to material or production faults but can sometimes be caused by incorrect use or unfortunate circumstances. Therefore the following list of common fault symptoms is included.

### The platter doesn't turn although the unit is switched on:

- The unit is not connected to the mains power supply.
- No mains at the socket.
- Drive belt is not fitted or has slipped off.

### No signal through one or other channel or both channels:

- No signal contact from the cartridge to the internal tonearm wiring or from that to the arm lead or from that to the phono box or between that and the amplifier. This could be due to a faulty plug, broken wire or solder joint or simply loose plug/socket connection.
- Phono input not selected at amplifier.
- Amplifier is not switched on.
- Amplifier or speakers are defective or muted.
- No connection to the loudspeakers.

### Strong hum on phono input:

- No earth connection from cartridge or arm or arm cable to amplifier, or earth loop.

### Distorted or inconsistent sound from one or both channels:

- Record player is connected to wrong input of amplifier, or MM/MC switch incorrectly set.
- Needle or cantilever damaged.
- Wrong r.p.m., drive belt overstretched or dirty, platter bearing without oil, dirty or damaged

## Service

Should you encounter a problem which you are not able to alleviate or identify despite the above information, please contact your dealer for further advice. Only when the problem cannot be resolved there should the unit be sent to the responsible distributor in your country.

Guarantee repairs will only be affected if the unit is returned correctly packaged. For this reason we recommend keeping the original packaging.

Never return a record player without making sure that it is safely disassembled and correctly packaged in the original packaging according to the diagrams on the last page of this user guide. Please remove these parts and pack them separately: lid, counterweight, anti-skating weight and belt.

Fit the cartridge protection cap and the transport lock for the tonearm tube, prior to carefully packaging the record player.

## Warranty



*The manufacturer accepts no responsibility for damage caused by not adhering to these instructions for use and/or by transportation without the original packaging. Modification or change to any part of the product by unauthorized persons, release the manufacturer from any liability over and above the lawful rights of the customer.*

Pro-Ject Audio Systems is a Registered Trademark of H. Lichtenegger.

This guide was produced by: Pro-Ject Audio Systems  
Copyright © 2019. All rights reserved.

The information was correct at the time of going to press. The manufacturer reserves the right to make changes to the technical specification without prior notice as deemed necessary to uphold the ongoing process of technical development.

