



Questo manuale d'istruzione è fornito da trovaprezzi.it. Scopri tutte le offerte per [Shark Clean IZ300EU](#) o cerca il tuo prodotto tra le [migliori offerte di Aspirapolvere e Pulitrici](#)

[trovaprezzi.it](#)

Questo manuale d'istruzione è fornito da trovaprezzi.it. Scopri tutte le offerte per [Shark Clean IZ300EU](#) o cerca il tuo prodotto tra le [migliori offerte di Aspirapolvere e Pulitrici](#)

# **Shark**

## **Anti Hair Wrap, DuoClean® & Powerfins™ Cordless Vacuum**

IZ300UK Series  
IZ320UK Series

### **INSTRUCTIONS**

---



**duo**clean® **POWERFINS™**

# THANK YOU

for purchasing the Shark® Anti Hair Wrap, DuoClean® & Powerfins™ Cordless Vacuum





**TIP:** You can find the model and serial numbers on the QR code label located on the back of your unit.

**TIP:** You can locate the date code on one of the prongs of the power cord plug.

## REGISTER YOUR PURCHASE

### TO BENEFIT FROM YOUR PRODUCT'S EXTENDED GUARANTEE, SIMPLY REGISTER YOUR PURCHASE AT:

-  [sharkclean.co.uk/register-guarantee](http://sharkclean.co.uk/register-guarantee)
-  +44 (0)800 862 0453
-  Scan QR code using mobile device

Please note, products purchased directly from Shark are automatically registered.

Benefits of registering your product and creating an account:

- Get easier, faster product support and access to guarantee information
- Access troubleshooting and product care instructions
- Be among the first to know about exclusive product promotions

## RECORD THIS INFORMATION

Model Number: \_\_\_\_\_

Serial Number: \_\_\_\_\_

Date Code: \_\_\_\_\_

Date of Purchase (Keep Receipt): \_\_\_\_\_

Store of Purchase: \_\_\_\_\_

## TECHNICAL SPECIFICATIONS

Voltage: 25.2V

Body Motor Watts: 309W

Nozzle Watts: 80W

## PLEASE READ CAREFULLY AND KEEP FOR FUTURE REFERENCE.

This instruction manual is designed to help you get a complete understanding of your new Shark Anti Hair Wrap, DuoClean® & Powerfins™ Cordless Vacuum.

If you have any questions, please call the customer service line on +44 (0)800 862 0453.



# CONTENTS

<b>Product Registration</b> .....	<b>2</b>
<b>Important Safety Instructions</b> .....	<b>4</b>
<b>Assembling your Shark® Vacuum Cleaner</b> .....	<b>6</b>
<b>Using Your Lithium ION Power Pack Battery</b> .....	<b>7</b>
LED battery Power and Charging Indicators .....	7
Recycling your Lithium ION Power Pack Battery .....	7
<b>Charging Your Lithium ION Power Pack Battery</b> .....	<b>8</b>
<b>Settings</b> .....	<b>9</b>
<b>Cleaning Modes</b> .....	<b>10</b>
<b>Using the Flexology® Wand</b> .....	<b>11</b>
Flexology Reach .....	11
Flexology Storage .....	11
<b>Maintaining your Vacuum Cleaner</b> .....	<b>12</b>
Emptying the Dust Cup .....	12
Removing and Cleaning the Dust Cup .....	12
Cleaning the Filters .....	13
Maintaining the Floor Nozzle .....	14
Checking for blockages .....	15
<b>Troubleshooting Guide</b> .....	<b>16</b>
<b>Additional Accessories Available</b> .....	<b>17</b>
<b>Guarantee</b> .....	<b>18</b>
<b>Battery Guarantee</b> .....	<b>19</b>



This marking indicates that this product should not be disposed with other household wastes. To prevent possible harm to the environment or human health from uncontrolled waste disposal, recycle it responsibly to promote the sustainable reuse of material sources. To return your used device, please use the return and collection systems or contact the retailer where this product was purchased. They can take this product for environmentally safe recycling.

# IMPORTANT SAFETY INSTRUCTIONS

**FOR HOUSEHOLD USE ONLY • PLEASE READ ALL INSTRUCTIONS BEFORE USING THIS VACUUM.**

**To reduce the risk of shock and unintended operation, turn off power and remove the ION Power Pack battery before servicing.**

**NOTE: If you have delicate or wool carpets, particularly loop pile, please try the vacuum on a hidden area first to ensure the spinning brush-rolls do not damage or unpick carpet fibres.**

## **⚠ WARNING**

**REDUCE THE RISK OF FIRE, ELECTRIC SHOCK, INJURY, OR PROPERTY DAMAGE:**

1. This vacuum consists of a motorised nozzle, wand, and handheld vacuum. These components contain electrical connections, electrical wiring, and moving parts that potentially present risk to the user.
  2. Before each use, carefully inspect all parts for any damage. If a part is damaged, discontinue use.
  3. Use only identical replacement parts.
  4. This vacuum contains no serviceable parts.
  5. Use only as described in this manual. **DO NOT** use the vacuum for any purpose other than those described in this manual.
  6. With the exception of the filters and dust cup, **DO NOT** expose any parts of the vacuum to water or other liquids.
  7. **DO NOT** allow the appliance to be used by children. Keep the appliance and its cord out of reach of children. Do not allow to be used as a toy. Close supervision is necessary when used near children.
- GENERAL USE**
8. This appliance can be used by persons with reduced physical, sensory or mental capabilities or lack of experience and knowledge if they have been given supervision or instruction concerning use of the appliance in a safe way and understand the hazards involved. Cleaning and user maintenance should not be done by children.
  9. Always turn off the vacuum before connecting or disconnecting any current carrying hoses, motorised nozzles, chargers, batteries, or other electrical or mechanical parts.
  10. **DO NOT** handle plug or vacuum with wet hands.
  11. **DO NOT** use without dust cup, filters, and brush-roll in place.
  12. Only use Shark® branded filters and accessories. Damage caused by non-Shark filters and accessories may not be covered by the warranty.
  13. **DO NOT** put any objects into nozzle or accessory openings. **DO NOT** use with any opening blocked; keep free of dust, lint, hair, and anything that may reduce airflow.
  14. **DO NOT** use if nozzle or accessory airflow is restricted. If the air paths or the motorised floor nozzle become blocked, turn the vacuum off. Remove all obstructions before you turn on the unit again.
  15. Keep nozzle and all vacuum openings away from hair, face, fingers, uncovered feet, or loose clothing.
  16. **DO NOT** use if vacuum is not working as it should, or has been dropped, damaged, left outdoors, or dropped into water.
  17. Use extra care when cleaning on stairs.
  18. **DO NOT** leave the vacuum unattended while powered on.
  19. When powered on, keep the vacuum moving over the carpet surface at all times to avoid damaging the carpet fibres.
  20. If you have delicate or wool carpets, particularly loop pile, please try the vacuum on a hidden area first to ensure the spinning brush-rolls do not damage or unpick carpet fibres.

**21. DO NOT** use to pick up:

- a) Liquids
- b) Large objects
- c) Hard or sharp objects (glass, nails, screws, or coins)
- d) Large quantities of dust (including drywall, fireplace ash, or embers). **DO NOT** use as an attachment to power tools for dust collection.
- e) Smoking or burning objects (hot coals, cigarette butts, or matches)
- f) Flammable or combustible materials (lighter fluid, petrol, or kerosene)
- g) Toxic materials (chlorine bleach, ammonia, or drain cleaner)

**22. DO NOT** use in the following areas:

- a) Poorly lit areas
- b) Wet or damp surfaces
- c) Outdoor areas
- d) Spaces that are enclosed and may contain explosive or toxic fumes or vapours (lighter fluid, petrol, kerosene, paint, paint thinners, mothproofing substances, or flammable dust)

**23.** Turn off the vacuum before plugging in or unplugging the charger.

**24.** Turn off the vacuum before any adjustment, cleaning, maintenance or troubleshooting.

**25.** During cleaning or routine maintenance, **DO NOT** cut anything other than hair, fibres, or string wrapped around the brush-roll.

**26.** Allow all filters to air-dry completely before replacing in the vacuum to prevent liquid from being drawn into electric parts.

**27. DO NOT** modify or attempt to repair the vacuum or the battery yourself, except as indicated in this manual. **DO NOT** use the battery or vacuum if it has been modified or damaged. Damaged or modified batteries may exhibit unpredictable behavior resulting in fire, explosion or risk of injury.

**28.** Turn off all controls before unplugging.

**29.** Always turn off this appliance before connecting or disconnecting motorised nozzle or hand tool.

## **BATTERY PACK**

30. The battery is the power source for the vacuum. Carefully read and follow all charging instructions.
31. To prevent unintentional starting, ensure the vacuum is powered off before picking up or carrying the vacuum. **DO NOT** carry the appliance with your finger on the power switch.
32. Use only the charger supplied with the unit. Use of an incorrect charger may result in no charging, and/or unsafe conditions. A charger that is suitable for one type of battery pack may create a risk of fire when used with another battery pack.
33. Keep the battery away from all metal objects such as paper clips, coins, keys, nails, or screws. Shorting the battery terminals increases the risk of fire or burns.
34. Under abusive conditions, liquid may be ejected from the battery. Avoid contact with this liquid, as it may cause irritation or burns. If contact occurs, flush with water. If liquid contacts eyes, seek medical help.
35. Battery should not be stored at temperatures below 3°C (37.4°F) or above 104°F (40°C) to maintain long-term battery life.
36. **DO NOT** charge battery at temperatures below 5°C (40°F) or above 104°C (104°F). Charging improperly or at temperatures outside of the specified range may damage the battery and increase the risk of fire.
37. Store the appliance indoors. **DO NOT** use or store it below 3°C (37.4°F). Ensure the appliance is at room temperature before operating.
38. **DO NOT** expose the battery to fire or temperatures above 265°F (130°C) as it may cause explosion.
39. Use appliances only with specifically designated battery packs. Use of any other battery packs may create a risk of injury and fire.
40. Disconnect the battery pack from the appliance before making any adjustments, changing accessories, or storing appliance. Such preventive safety measures reduce the risk of starting the appliance accidentally.

# SAVE THESE INSTRUCTIONS

1. Insert **Wand** into **Floor Nozzle**.
2. Insert **Handheld Vacuum** into wand.

For proper operation, ensure all components are completely connected and clicked into place.

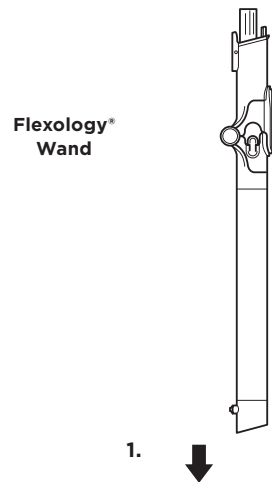
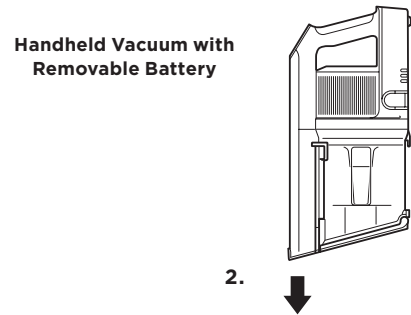

The Lithium ION Power Pack battery does not come fully charged. Prior to first use, charge completely. During first use, run the battery down until it is completely out of power. This will condition the battery.

**LED BATTERY POWER AND CHARGING INDICATORS**

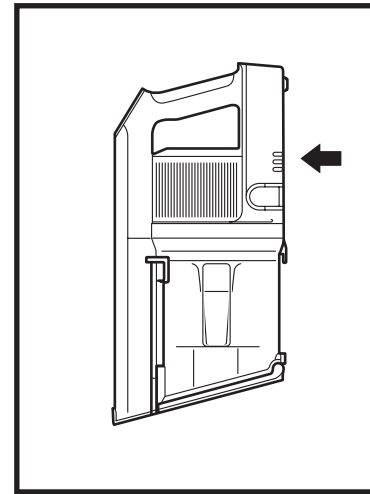

**Charging**

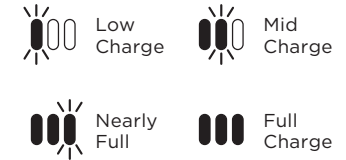

*NOTE: Full charge takes approximately 4 hours.*

**RECYCLING THE LI-ION BATTERY**

This product uses a Lithium ION rechargeable and recyclable battery. When the battery no longer holds a charge, it should be removed from the vacuum and recycled. **DO NOT** incinerate or compost the battery.

When your Lithium ION Power Pack Battery needs to be replaced, dispose of it or recycle it in accordance with local regulations. In some areas, it is illegal to place spent Lithium ION batteries in the bin or in a municipal solid waste stream. Return spent power packs to an authorised recycling center or to retailer for recycling. Contact your local recycling center for information on where to drop off the spent power pack.

To charge, remove the handheld vacuum from the wand by pressing the Wand Release button and pulling up. Plug the charger into the charging port.

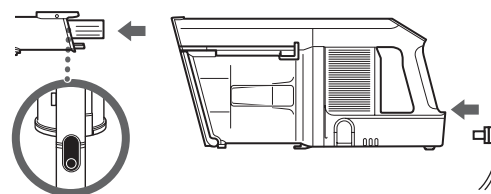

## CHARGING THE BATTERY

### USING THE LI-ION CHARGER

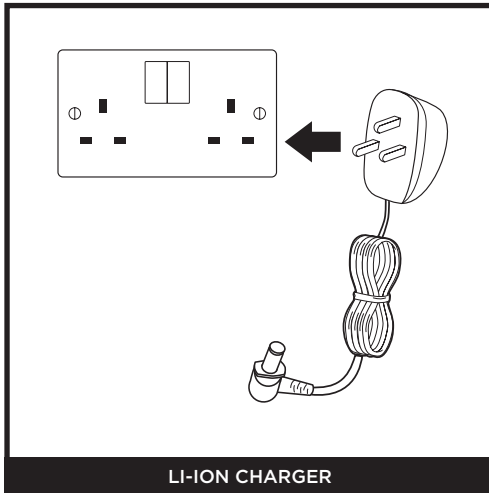

LI-ION CHARGER

Plug the **Li-Ion Charger** into a wall outlet.

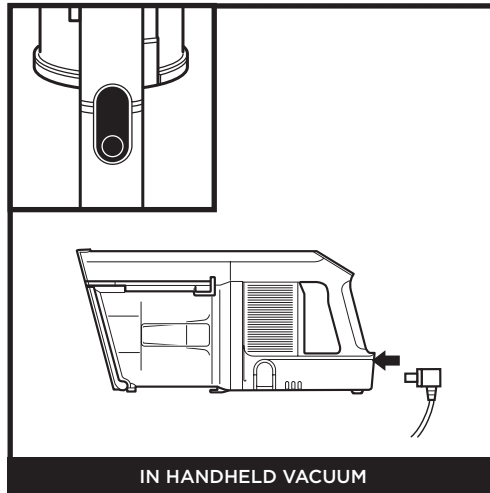

IN HANDHELD VACUUM

To charge simply plug the charger into the charging port while still attached to the wand.

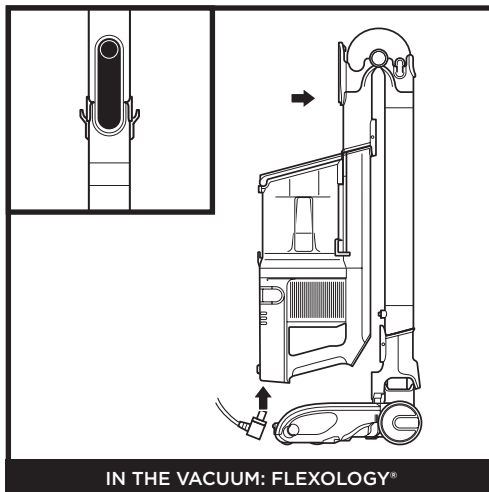

IN THE VACUUM: FLEXOLOGY®

To put the vacuum in storage mode, press the **FLEXOLOGY® Wand Unlock Latch** while folding the handheld vacuum forward until the wand clicks and locks. Plug the charger into the charging port on the handheld vacuum.

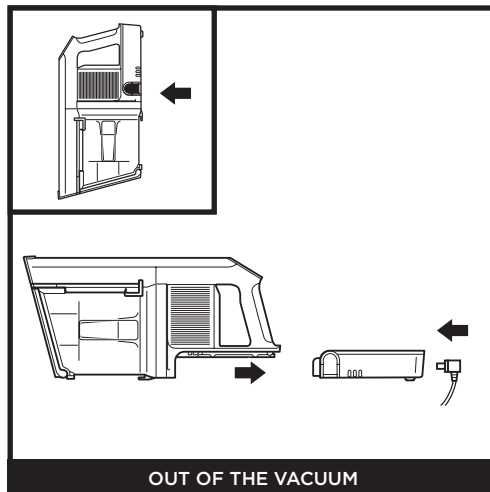

OUT OF THE VACUUM

The battery is removable, press and hold the **Battery Release Button**, then slide out the battery. Plug the charger into the charging port on the battery. To reinstall the battery, slide it into the slot in the back of the handheld vacuum.

## SETTINGS

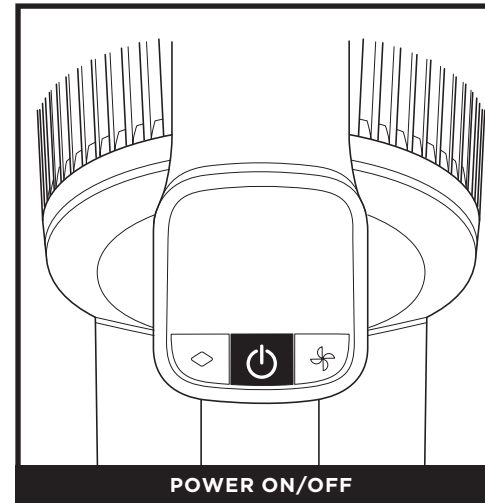

POWER ON/OFF

Press power button to turn on or off the vacuum.

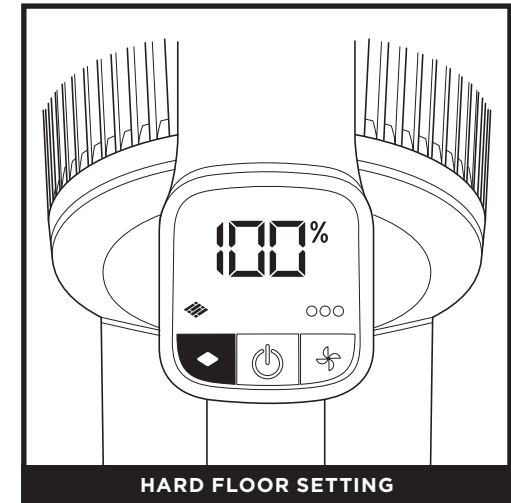

HARD FLOOR SETTING

To vacuum in hard floor mode, press the floor select button until the hard floor icon (🌀) illuminates. The brushrolls will spin slowly to clean bare floors and small area rugs.

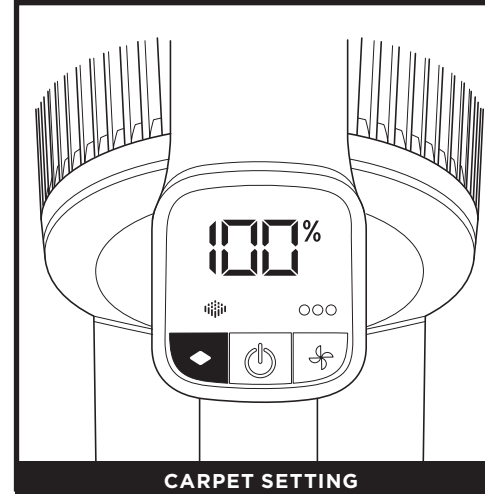

CARPET SETTING

To vacuum in carpet mode, press the floor select button until the carpet icon (🌀) illuminates. The brushrolls will spin faster to help pick up dust below the surface of your carpets.

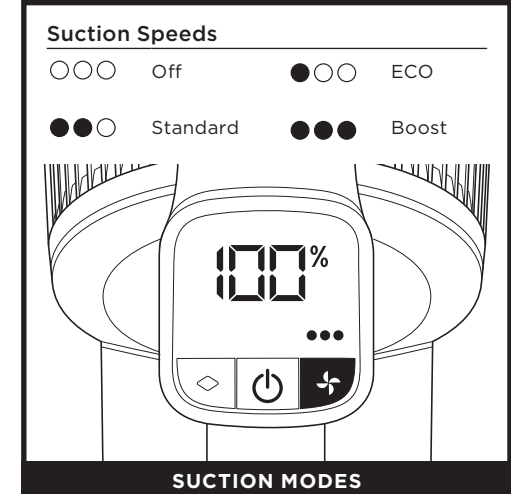

SUCTION MODES

Press the 🌀 button to toggle between ECO, Standard and Boost modes. To save battery power, select ECO mode. For everyday cleaning, select Standard. For extra power, select Boost mode.

## CLEANING MODES

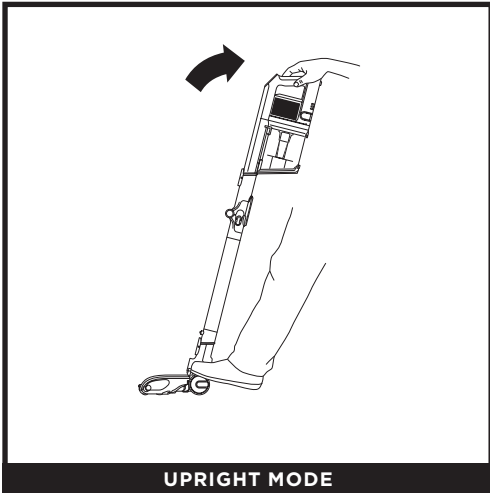

**UPRIGHT MODE**

To clean floors, place foot on floor nozzle and tilt handheld vacuum back.

**NOTE:** Brushrolls will only engage when the handheld vacuum is tilted back.

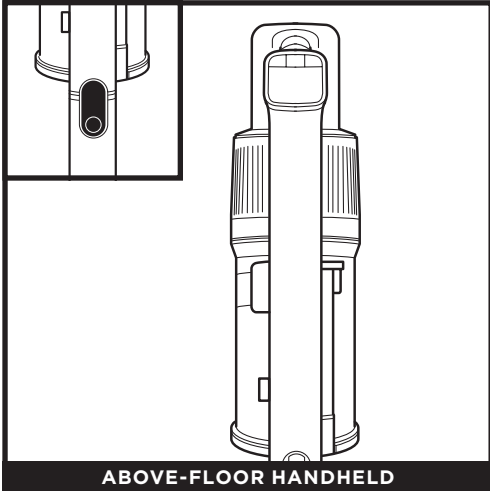

**ABOVE-FLOOR HANDHELD**

Press the wand release button and lift the handheld vacuum off the wand. Attach an accessory for great cleaning on stairs, furniture, and other above-floor areas.

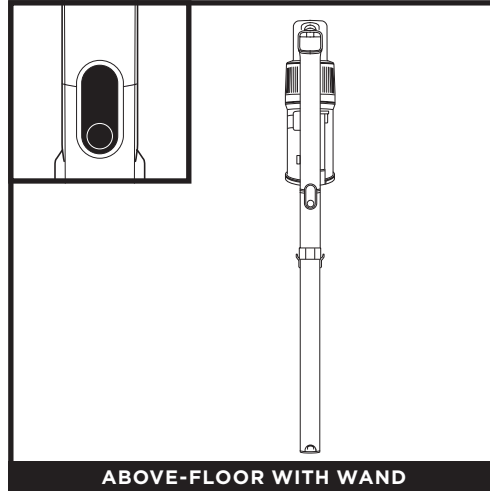

**ABOVE-FLOOR WITH WAND**

Stand the vacuum upright and press the nozzle release button located at the bottom of the wand, above the nozzle. Lift wand to detach.

Attach an accessory for great cleaning on skirting boards, ceiling fans, window sills, and other hard-to-access areas.

**NOTE:** All accessories are compatible with both the wand and the handheld vacuum.

## USING THE FLEXOLOGY® WAND

### FLEXOLOGY REACH

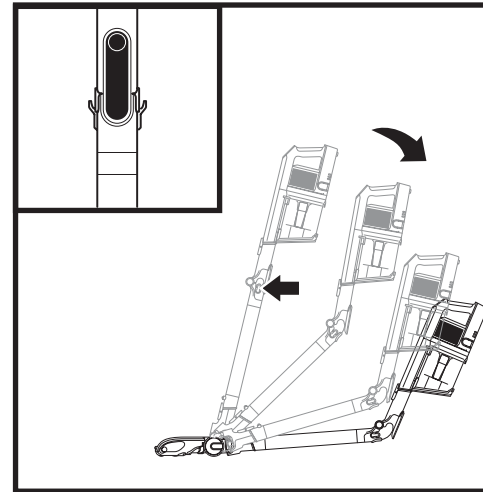

Press the unlock latch on the back of the wand, then adjust the angle.

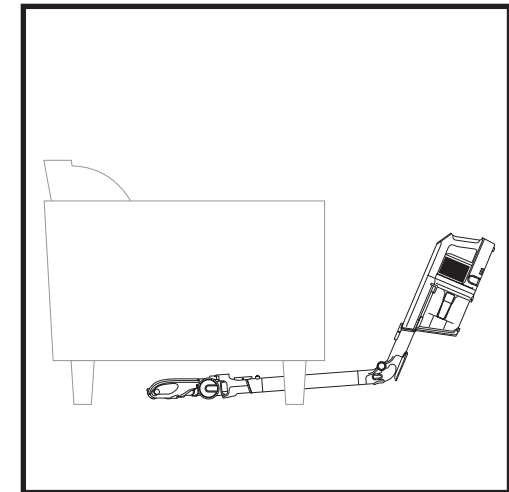

Adjust the wand to a lower angle to easily clean under furniture.

### FLEXOLOGY STORAGE

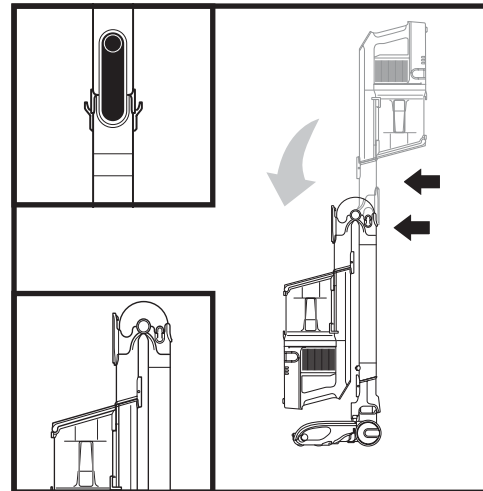

To put the vacuum in storage mode, press the unlock latch while folding the handheld vacuum forward.

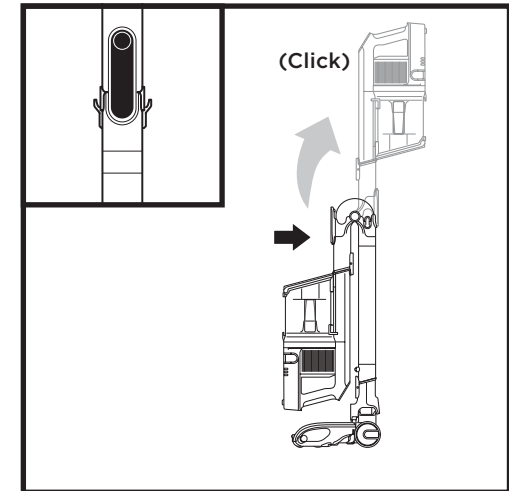

To take the vacuum out of storage mode, press the unlock latch and lift up the handheld vacuum until the wand clicks and locks into place.

**NOTE:** Take care whenever folding or unfolding the wand to ensure fingers cannot be caught in the mechanism.

EMPTYING THE DUST CUP

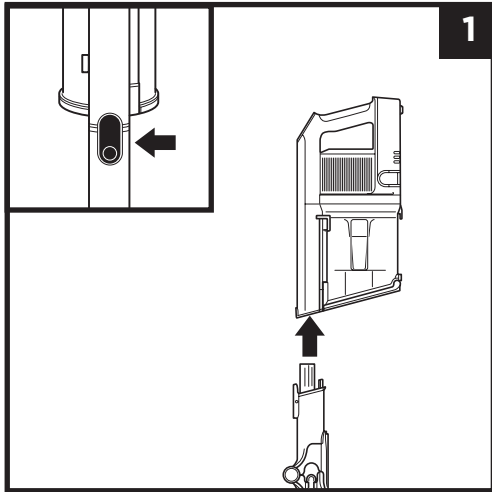

Press the wand release button to detach the handheld vacuum from the wand.

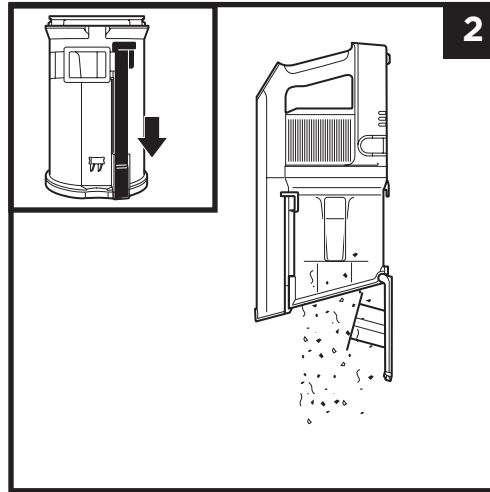

To empty the Dust Cup while it is attached to the handheld vacuum, position the dust cup over a bin and slide the lid release slider forward.

REMOVING AND CLEANING THE DUST CUP

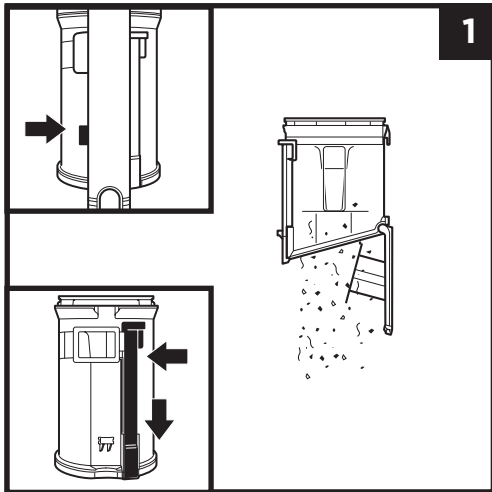

To remove the dust cup from the handheld vacuum, press the **Dust Cup Release** button near the handheld vacuum nozzle. Tilt the dust cup and lift off to remove.  
To empty dust and debris, hold the dust cup over the bin, then slide the CleanTouch Dirt Ejector slider forward.

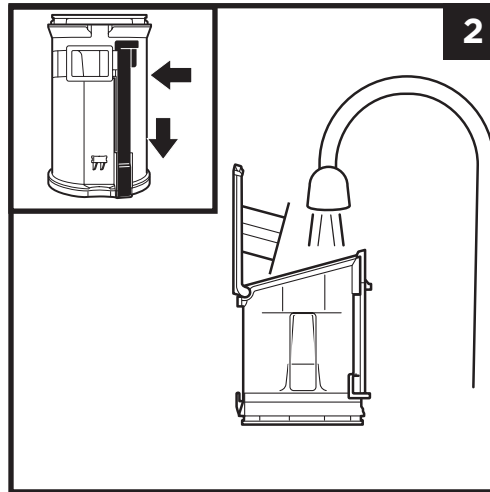

To clean the interior of the dust cup, rinse it with water. Place it on its side with the lid open to air-dry for at least 24 hours before reinstalling.

CLEANING THE FILTERS

**Regularly rinse and reinstall the filters to maintain your vacuum's suction power.**

To clean filters, rinse them with water only. Allow all filters to air-dry completely before reinstalling to prevent liquid from being drawn into electric parts. Clean the pre-motor filters at least once a month and post-motor filter at least once a year. Tap off loose dirt between washes when needed. More frequent cleaning may sometimes be necessary with heavy use.

**IMPORTANT: DO NOT** use soap when cleaning the filters. Use water only. The vacuum will not have suction if the post-motor filter is not installed. Ensure that all filters are installed before using.

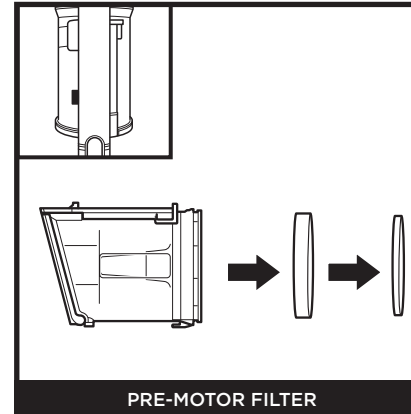

Press the dust cup release button and remove the dust cup. Pull the foam and felt filters out of the back of the dust cup.

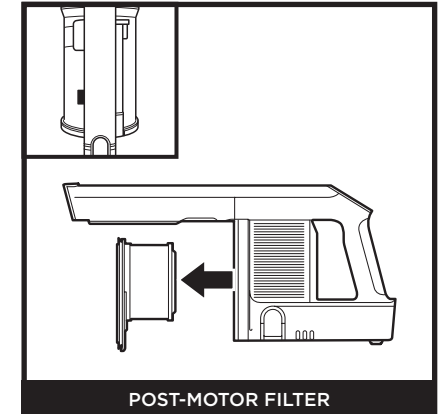
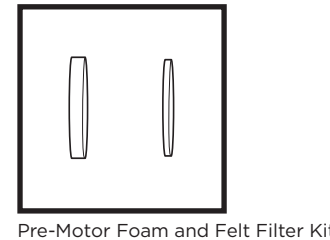

Remove the dust cup. Pull the post-motor filter out of the handheld vacuum.

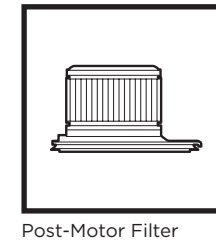

FLOOR NOZZLE

If any hair is wrapped around the brushroll, continue cleaning using the Carpet setting on a bare floor surface, a low-pile carpet, or a small area rug. If some fibres remain wrapped around the brushroll after continued use, carefully remove them. If you run over a hard or sharp object or notice a noise change while vacuuming, check for blockages by following the steps under 'Checking for Blockages in the Floor Nozzle' on the bottom right of this page.

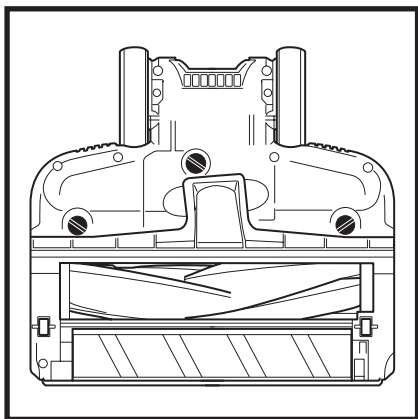

CLEANING SOFT ROLLER

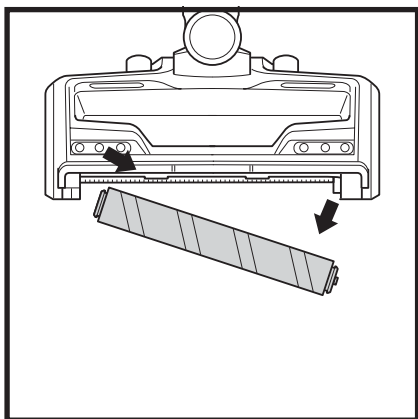

- 1 To remove Soft Roller from nozzle, pull the Soft Roller out by the tab.
- 2 Tap loose debris off the Soft Roller. Use a dry towel to wipe the Soft Roller clean and to remove any debris caught in the teeth behind the Soft Roller.
- 3 Hand wash the Soft Roller as needed. Use only water, and let air-dry completely, which should take at least 24 hours.
- 4 Reinsert the Soft Roller.

CHECKING FOR BLOCKAGES

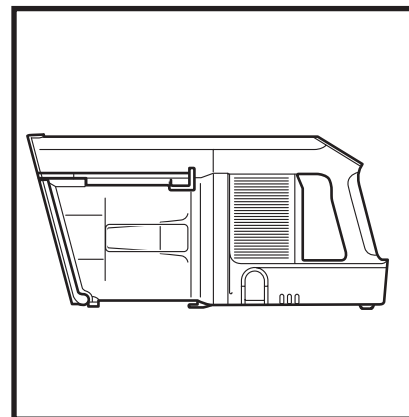

Checking for Blockages in the Handheld Vacuum:

1. Turn off vacuum.
2. Remove the handheld vacuum from the wand.
3. Check all intake openings on the dust cup and remove any debris or blockage.

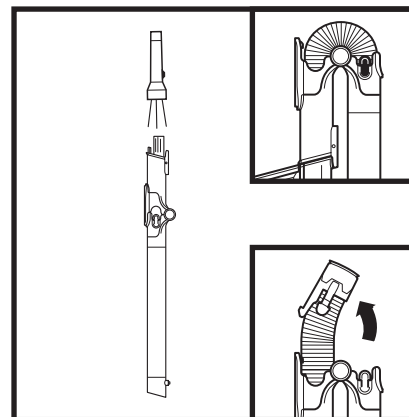

Checking for Blockages in the Wand:

Standard Wand:

1. Turn off vacuum.
2. Remove the handheld vacuum and floor nozzle.
3. Check intake openings for blockages and debris.
4. Clear away debris and blockages.

Flexology® Wand:

1. Turn off vacuum.
2. Remove the handheld vacuum and floor nozzle from the wand.
3. Check the **Clog Access Hose** on the Flexology section of the wand by pinching the tabs on both sides of the hose and lifting the hose out.
4. Clear any debris and blockages.

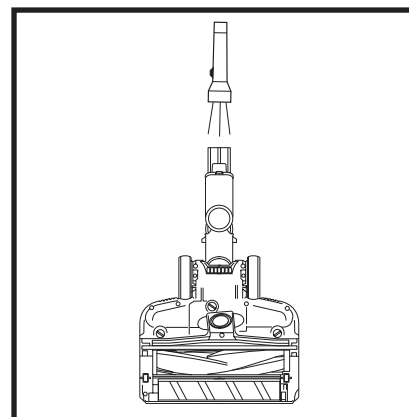

Checking for Blockages in the Floor Nozzle:

1. Turn off vacuum.
2. Detach the wand.
3. Use the edge of a coin to open the three locks on the bottom of the floor nozzle.
4. Remove the cover and tilt back the neck of the floor nozzle.
5. Check the opening and remove any debris.
6. Replace the cover by sliding the inserts into the slots, then pressing down firmly on all sides before turning the locks clockwise to close, until they click securely into place.

**⚠ WARNING: To reduce the risk of shock and unintended operation, turn off power and remove the Lithium ION Power Pack battery before servicing.**

**Vacuum is not picking up debris. No suction or light suction. Nozzle light is red. (Refer to Checking for Blockages section for more information.)**

- Check filters to see if they need cleaning. Follow instructions for rinsing and completely air-drying the filters before reinserting in the vacuum.
- Dust cup may be full; empty dust cup.
- Check floor nozzle for blockages; clear blockages if required.
- Remove any string, carpet fibres, or hair that may be wrapped around the brushroll.
- Check connection between handheld vacuum and wand for blockages; clear blockages if required. If the issue persists, please contact Customer Service.
- Check clog access in wand for any blockages and clear any debris.

**Vacuum lifts area rugs.**

- Make sure you are not engaging Boost mode as this can be too much suction for lighter rugs. Take care when vacuuming area rugs or rugs with delicately sewn edges.
- Turn off the unit to disengage the brushroll and restart with the power/selector switch.

**Brushrolls do not spin.**

- Immediately turn off the vacuum. Remove any blockages before turning the vacuum back on. Make sure the handheld vacuum is tilted back far enough for the brushrolls to engage. If the brushrolls still do not spin, please contact Customer Service.
- If the floor nozzle has headlights and they are not illuminated, there is a connection issue between the handheld vacuum, wand, and nozzle. Try disconnecting and reattaching the pieces. If the headlights still do not illuminate, please contact Customer Service.

**Vacuum turns off on its own.**

There are several possible reasons for the vacuum turning off on its own, including blockages, battery issues, and overheating. If vacuum turns off on its own, perform the following steps:

- Turn on the vacuum and check the battery indicator lights located on the handheld vacuum. If recharging is needed, make sure power is turned off before connecting to the charger.
- Empty dust cup and clean filters (see Emptying the Dust Cup and Cleaning the Filters section).
- Check wand, accessories, and inlet openings and remove any blockages.
- Allow unit and battery to cool for at least 45 minutes, until they return to room temperature.
- Press power button to restart the vacuum.

**NOTE:** If vacuum still does not operate properly, contact Customer Service at +44 (0)800 862 0453

**Battery Indicator Lights on handheld vacuum are flashing.**

- Bottom LED light is flashing (Fig. A): Battery needs to be charged.
- Top and bottom LED lights are flashing (Fig. B): Battery temperature is not optimal, so charging is temporarily paused. Leave battery plugged in and charging will resume soon.
- If top 2 or bottom 2 LED lights are flashing (Fig. C, Fig. D), call Customer Service at +44 (0)800 862 0453



Fig. A



Fig. B



Fig. C



Fig. D

- Ⓐ 8" Crevice Tool
- Ⓑ 18" Flexi Crevice Tool
- Ⓒ Duster Crevice Tool
- Ⓓ Dusting Brush
- Ⓔ Multi-Angle Dusting Brush
- Ⓕ Anti-Allergen Dust Brush
- Ⓖ Upholstery Tool
- Ⓗ Wide Upholstery Tool
- Ⓘ Multi Surface Tool
- Ⓝ Deep-Cleaning Motorised Pet Tool
- Ⓚ Flexology® Under-Appliance Wand
- Ⓛ Accessory Bag
- Ⓜ Li-Ion Charger
- Ⓝ Dual Li-Ion Charger
- Ⓞ Li-Ion Battery
- Ⓟ Car Maintenance Kit

A



B



C



D



E



F



G

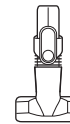

H

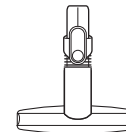

I

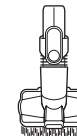

J

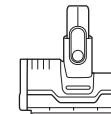

K



L



M



N



O



P

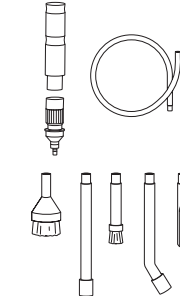

**NOTE:** Not all accessories come with all units. For a list of the accessories included with this model, see the top inside flap of the box. To order additional accessories, visit [sharkninja.co.uk](http://sharkninja.co.uk)

## FIVE (5) YEAR LIMITED GUARANTEE

When a consumer buys a product in the UK, they get the benefit of legal rights relating to the quality of the product (your "statutory rights"). You can enforce these rights against your retailer. However, at Shark we are so confident about the quality of our products that we give the product owner an additional manufacturer's guarantee of up to five years (1 year as standard plus 4 years when you register). These terms and conditions relate to our manufacturer's guarantee only - your statutory rights are unaffected.

The conditions below describe the prerequisites and scope of our guarantee. They do not affect your statutory rights or the obligations of your retailer and your contract with them.

The Lithium ION power pack is not covered by the 5 year guarantee (see battery guarantee on next page).

### Shark® Guarantees

A household appliance like a vacuum cleaner constitutes a sizeable investment. Your new machine needs to work properly for as long as possible. The guarantee it comes with is an important consideration - and reflects how much confidence the manufacturer has in its product and manufacturing quality.

Every Shark machine comes with a free parts and labour guarantee. Our customer service helpline (0800 862 0453) is open from 9.00am to 6.00pm Monday - Friday. It's free to call, and you'll be put straight through to a Shark representative. You'll also find online support at [www.sharkclean.co.uk](http://www.sharkclean.co.uk)

### How do I register my extended Shark® guarantee?

You can register your guarantee online within 28 days of purchase. To save time, you'll need the following information about your machine:

- Date you purchased the machine (receipt or delivery note)

To register online, please visit [www.Sharkclean.eu/uk/register-guarantee](http://www.Sharkclean.eu/uk/register-guarantee). Products purchased directly from Shark are automatically registered.

### IMPORTANT

- Both the 12 months and the extended 4 years guarantee will only cover your product from the date of purchase.
- Please keep your receipt at all times. Should you need to use your extended guarantee we will need your receipt to verify the information you have supplied to us is correct. The inability to produce a valid receipt may invalidate your guarantee.

### What are the benefits of registering my free Shark® guarantee?

When you register your guarantee we'll have your details to hand if we ever need to get in touch. If you further agree to receive communications from us, you can also receive tips and advice on how to get the best out of your Shark vacuum and hear the latest news about new Shark technology and launches.

If you register your guarantee online, you'll get instant confirmation that we've received your details.

### How long are new Shark® machines guaranteed for?

Our confidence in our design and quality control means that your new Shark vacuum cleaner is guaranteed for a total of up to five years (12 months plus an extended guarantee of 4 years).

### What is covered by the free Shark® guarantee?

Repair or replacement (at Shark's discretion) of your Shark machine, including all parts and labour. A Shark guarantee is in addition to your legal rights as a consumer.

### What is not covered by the free Shark® guarantee?

1. Blockages - for details of how to unblock your vacuum cleaner, please refer to the Operating Manual.
2. Normal wear and tear such as brush bar, fuse, belt, hose etc.
3. Accidental damage, faults caused by negligent use or care, misuse, neglect, careless operation or handling of the vacuum cleaner which is not in accordance with the Shark Operating Manual supplied with your machine.
4. Use of the vacuum cleaner for anything other than normal domestic household purposes.
5. Use of parts not assembled or installed in accordance with the operating instructions.
6. Faults caused by use of parts and accessories which are not Shark Genuine Components.
7. Faulty installation (except where installed by Shark).
8. Repairs or alterations carried out by parties other than Shark or its agents.
9. The Lithium ION power pack battery. Please see next page for battery guarantee.

### What happens when my guarantee runs out?

Shark does not design products to last for a limited time. We do appreciate that there may be a desire for our customers to want to repair their vacuum cleaners after the guarantee has lapsed. In this case please contact our Freephone customer service help line and ask about our out of guarantee programme, on 0800 862 0453.

### Where can I buy genuine Shark® spares and accessories?

Shark spares and accessories are developed by the same engineers who developed your Shark vacuum. You'll find a full range of Shark spares, replacement parts and accessories for all Shark machines at [www.sharkclean.co.uk](http://www.sharkclean.co.uk).

Please remember that damage caused by use of non-Shark spares is not covered under your guarantee.

## TWO (2) YEAR LIMITED BATTERY GUARANTEE

When a consumer buys a product in the UK, they get the benefit of legal rights relating to the quality of the product (your "statutory rights"). You can enforce these rights against your retailer. However, at Shark® we are so confident about the quality of our products that we give you an additional manufacturer's guarantee on the batteries of up to two years (1 year as standard plus 1 year when you register). These terms and conditions relate to our manufacturer's guarantee only - your statutory rights are unaffected.

Every Shark® battery comes with a free parts and labour guarantee. Our customer service helpline (0800 862 0453) is open from 9.00am to 6.00pm Monday - Friday. It's free to call, and you'll be put straight through to a Shark® representative. You'll also find online support at [www.Sharkclean.co.uk](http://www.Sharkclean.co.uk).

### How do I register my extended Shark® guarantee?

You can register your guarantee online within 28 days of purchase. To save time, you'll need the following information about your machine/battery:

- Model Number
- Date you purchased the machine/battery (from your in-store receipt or delivery note)

To register online, please visit [www.Sharkclean.co.uk/register-guarantee](http://www.Sharkclean.co.uk/register-guarantee). Products purchased directly from Shark are automatically registered.

### IMPORTANT

- The manufacturer's guarantee covers your battery for 12 months (or for 2 years, if registered) starting on the date of purchase.
- Please keep your receipt at all times. Should you need to use your guarantee (standard 1 year or further 1 year extended) we will need your receipt to verify the information you have supplied to us is correct. The inability to produce a valid receipt may invalidate your guarantee.

### How long are new Shark® batteries guaranteed for?

Our confidence in our design and quality control means that your new Shark® vacuum cleaner battery is guaranteed for a total of two years (12 months plus an extended guarantee of 1 year).

### What is covered by the free Shark® guarantee?

Repair or replacement of your Shark® battery (at Shark's discretion to decide whether to replace or repair) including all parts and labour. A Shark® guarantee is in addition to your legal rights as a consumer.

### What is not covered by the free Shark® guarantee?

1. Normal wear and tear of parts which require regular maintenance and/or replacement to ensure the proper functioning of your unit.
2. Accidental damage, faults caused by negligent use or care, misuse, neglect, careless operation or handling of the battery which is not in accordance with the Shark® Instructions supplied with your machine.
3. Use of the battery for anything other than powering the Shark® vacuum cleaner with which it was supplied.
4. Use of parts not assembled or installed in accordance with the operating instructions.
5. Use of parts and accessories which are not Shark® spares.
6. Faulty installation (except where installed by Shark®).

### Where can I buy genuine Shark® batteries?

Shark® batteries are developed by the same engineers who developed your Shark® vacuum. You'll find a full range of replacement batteries for all Shark® machines at [www.sharkclean.co.uk](http://www.sharkclean.co.uk). Please remember that damage caused by use of non-Shark® batteries may be not covered under your guarantee. However, your statutory rights are unaffected.



**PLEASE READ CAREFULLY AND KEEP FOR FUTURE REFERENCE.**

This Instruction Guide is designed to help you get a complete understanding of your new Shark® vacuum.

**SharkNinja Europe Limited,  
3150 Century Way, Thorpe Park,  
Leeds, LS15 8ZB, UK  
+44 (0)800 862 0453  
[www.sharkclean.co.uk](http://www.sharkclean.co.uk)**

**SharkNinja Germany GmbH  
c/o Regus Management GmbH,  
Excellent Business Center 10  
+11/Stock, Westhafenplatz 1,  
60327 Frankfurt am Main, Germany  
[www.sharkclean.eu](http://www.sharkclean.eu)**

Illustrations may differ from actual product. We are constantly striving to improve our products; therefore the specifications contained herein are subject to change without notice.

© 2021 SharkNinja Operating LLC. DUOCLEAN, FLEXOLOGY and SHARK are registered trademarks of SharkNinja Operating LLC.

POWERFINS is a trademark of SharkNinja Operating LLC.