



Questo manuale d'istruzione è fornito da [trovaprezzi.it](http://trovaprezzi.it). Scopri tutte le offerte per [Silex SX-ND-4350WAN Plus](#) o cerca il tuo prodotto tra le [migliori offerte di Altri dispositivi di rete](#)

WA103900XX

# **Wired / Wireless Serial Device Server SD-300/SD-320AN**

---

## **User's Manual**

**silex**  
technology



---

# Index

<b>1. Introduction .....</b>	<b>1</b>
1-1. Introduction .....	2
About the notation .....	2
Disclaimers.....	2
Trademarks .....	2
1-2. Safety Instructions .....	3
1-3. User Registration and Customer Services .....	6
User registration.....	6
Product Information .....	6
Customer Support Center .....	7
<b>2. About SD-300/SD-320AN .....</b>	<b>9</b>
2-1. Package Contents .....	10
2-2. Features .....	11
2-3. Parts and Functions.....	13
Parts and Functions .....	13
Serial Port PIN Assignment and Serial Cable .....	16
2-4. LED Lighting Pattern .....	17
2-5. Hardware Specifications .....	19
2-6. Software Specifications.....	25
Software Specifications .....	25

---

RFC2217 Command List.....	26
2-7. Wireless Interference Information.....	27
Notes .....	27
2-8. Notes on Security .....	29
2-9. About OpenSSL License.....	30
<b>3. Software Overview .....</b>	<b>33</b>
3-1. What is Serial Device Server Setup? .....	34
Select Configuration Method.....	34
TCP/IP Settings .....	35
Wireless LAN Settings (only for SD-320AN).....	36
3-2. What is SX Virtual Link for Serial Device Server? .....	37
About SX Virtual Link for Serial Device Server .....	37
Functional Overview .....	38
3-3. Download the Utilities.....	39
<b>4. How to Configure(SD-300) .....</b>	<b>41</b>
4-1. Necessary items for Setup.....	42
4-2. Power on .....	43
4-3. Configure Network Settings.....	44
<b>5. How to Configure(SD-320AN).....</b>	<b>51</b>
5-1. Before Setup.....	52
Check your wireless LAN settings.....	52

---

---

About configuration methods.....	53
5-2. Necessary items for Setup.....	54
5-3. Power on .....	55
5-4. Configure Network Settings.....	56
5-5. Configure SD-320AN Using Smart Wireless Setup.....	63
Confirm that your wireless router supports WPS.....	63
Configure Network Settings .....	63
Push Button Method .....	65
PIN Code Method .....	67

## **6. How to Use..... 71**

6-1. Link to Serial Device Using the Serial Device Connection Utility.....	72
What is Serial Port Emulation Mode? .....	72
Install Application.....	73
Start SX Virtual Link for Serial Device Server .....	78
Link to a serial device .....	79
Start a serial communication software.....	83
Unlink from a serial device .....	83
6-2. Ecable Mode.....	84
What is Ecable Mode? .....	84
Before You Begin.....	84
Link to Serial Device .....	88

---

---

6-3. Raw TCP Connection Mode .....	89
What is Raw TCP Connection Mode? .....	89
Before You Begin .....	89
Link to Serial Device .....	92
6-4. Use Access Point Feature .....	93
Before You Begin .....	93
Link to Wireless Client Devices .....	95

## **7. Other Functions ..... 101**

7-1. Configure Using the SD-300/SD-320AN Web Page .....	102
Access the SD-300/SD-320AN Web Page .....	102
Log in to the SD-300/SD-320AN Web Page .....	105
Log out the SD-300/SD-320AN Web Page .....	106
Configure Advanced Network Settings .....	107
Configure Serial Port Settings .....	112
Configuration Item List .....	114
7-2. Security Settings .....	126
Change the Password .....	126
Allow Communication Only from a Particular PC .....	127
7-3. Maintenance .....	129
Reboot SD-300/SD-320AN .....	129
Reset to Factory Default .....	131
Update Firmware .....	134

---

7-4. Uninstall Application .....137

**8. Troubleshooting ..... 139**

8-1. Problems During the Setup.....140

8-2. Problems While Using SD-300/SD-320AN.....144

8-3. Wireless LAN Problems (SD-320AN Only).....148



# *1.* Introduction

---

Thank you for purchasing the Serial Device Server SD-300/SD-320AN.  
This manual provides information on how to configure and use SD-300/SD-320AN.  
Please read the **1-2.Safety Instructions** carefully before using SD-300/SD-320AN.

# 1-1. Introduction

---

## About the notation

- \* This manual uses the following symbols to indicate specific information for operating SD-300/SD-320AN.
- \* Be sure to carefully review before using SD-300/SD-320AN.



: This symbol indicates important information that needs to be observed when operating SD-300/SD-320AN. Make sure to read this information for safe and proper use.



: This symbol indicates information that is useful when using SD-300/SD-320AN. If you experience difficulties operating SD-300/SD-320AN, please refer to this information first.

## Disclaimers

- \* The unauthorized transfer or copying of the content of this manual, in whole or in part, without prior written consent is expressly prohibited by law.
- \* The content of this manual is subject to change without notice.
- \* This manual was prepared to accurately match the content of each OS, but the actual information shown on the computer monitor may differ from the content of this manual due to future OS version upgrades, modifications, and other changes.
- \* Although every effort was made to prepare this manual with the utmost accuracy, Silex Technology will not be held liable for any damages as a result of errors, setting examples, or other content.

## Trademarks



- \* Microsoft and Windows are either registered trademarks or trademarks of Microsoft Corporation in the United States and/or other countries.
- \* Other brand or product names are registered trademarks or trademarks of their respective owners.

## 1-2. Safety Instructions







This page provides the safety instructions for safe use of SD-300/SD-320AN.

To ensure safe and proper use, please read the following information carefully before using SD-300/SD-320AN. The safety instructions include important information on safe handling of SD-300/SD-320AN and on general safety issues.

### < Indication of the warning >

	<b>Warning</b>	"Warning" indicates the existence of a hazard that could result in death or serious injury if the safety instruction is not observed. result in bodily injury if the safety instruction is not observed.
	<b>Caution</b>	"Caution" indicates the existence of a hazard that could result in serious injury or material damage if the safety instruction is not observed.

### < Indication of the symbol >

	This symbol indicates the warning and notice. ( Example:  "Danger of the electric shock" )
	This symbol indicates the prohibited actions. ( Example:  "Disassembly is prohibited" )
	This symbol indicates the necessary actions. ( Example:  "Remove the AC plug from an outlet" )



## Warning

	<p>* In the following cases, turn off the connected devices and unplug the AC plug of this product from a power outlet. Failure to follow these instructions may cause fire or an electrical shock.</p> <ul style="list-style-type: none"> <li>- When this product emits a strange smell, smoke or sound or becomes too hot to touch.</li> <li>- When foreign objects (metal, liquid, etc.) gets into this product.</li> <li>- When this product is dropped or the case is broken or cracked.</li> </ul>
	<p>* Do not disassemble or modify this product. It may cause fire, electrical shock or malfunction.</p> <p>* Do not disassemble or modify the AC adaptor that came with this product. It may cause fire, electrical shock or malfunction.</p>
	<p>* Do not cover up the vents on this product. The temperature inside may rise and cause fire or malfunction.</p> <p>* Do not place any objects on top of this product. It may cause fire, electrical shock or malfunction.</p> <p>* Do not place any objects on top of this product. It may cause fire, electrical shock or malfunction.</p> <p>* Do not roll up or wrap the AC cord. It may cause fire or an electrical shock.</p> <p>* Do not plug or unplug the AC adaptor or any other cables with wet hands. It may cause an electrical shock or malfunction.</p> <p>* Keep the small parts out of reach of young children. If these are swallowed, consult a doctor immediately.</p>
	<p>* For use of the devices connected to this product, please follow all warnings, cautions and notices given by that manufacturer and carefully use them in a proper manner.</p> <p>* Failure to follow these instructions may cause fire, electrical shock or malfunction.</p> <p>* Use the correct power voltage. Improper voltage may cause fire or an electrical shock.</p> <p>* If a ground wire is supplied with your device to use with, connect it to the ground terminal in order to prevent an electrical shock. Do not connect the ground wire to gas pipe, water pipe, lighting rod or telephone ground wire. It may cause malfunction.</p> <p>* Keep the cords and cables away from children. It may cause an electrical shock or serious injury.</p>



## Caution

	<ul style="list-style-type: none"> <li>* Use the AC adaptor supplied with this product. Other AC adaptors may cause malfunction.</li> <li>* Do not place any objects on the cable or bend, twist, or pull it excessively.</li> <li>* Do not use or store this product under the following conditions.</li> <li>* It may cause malfunction.             <ul style="list-style-type: none"> <li>- Locations subject to vibration or shock</li> <li>- Shaky, uneven or tilted surfaces</li> <li>- Locations exposed to direct sunlight</li> <li>- Humid or dusty places</li> <li>- Wet places (kitchen, bathroom, etc.)</li> <li>- Near a heater or stove</li> <li>- Locations subject to extreme changes in temperature</li> <li>- Near strong electromagnetic sources (magnet, radio, wireless device, etc.)</li> </ul> </li> </ul>
	<ul style="list-style-type: none"> <li>* Do not pull on the cord to disconnect the plug from the power supply. The cord may be broken, which could result in fire or an electrical shock.</li> <li>* Follow the law of each country when you discard this product.</li> <li>* Verify all codes or cables are plugged correctly before using this product.</li> </ul>
	<ul style="list-style-type: none"> <li>* When this product will not be used for a long time, unplug the power cables of this product and the other devices you are using with it.</li> <li>* When removing this product, disconnect the AC plugs of both this product and the other devices you are using with it.</li> </ul>

## 1-3. User Registration and Customer Services

### User registration

To enable us to provide better services (support and repair), please perform the user registration process from our website below:

URL	
USA	<a href="http://www.silexamerica.com/support/product-registration/">http://www.silexamerica.com/support/product-registration/</a>
Europe	<a href="http://www.silexeurope.com/en/home/support/registration/">http://www.silexeurope.com/en/home/support/registration/</a>
Japan	<a href="http://www.silex.jp/register/">http://www.silex.jp/register/</a>



#### Note

\* For user registration, a serial number is required. It can be found on the bottom of SD-300/SD-320AN.

### Product Information

The services below are available from the Silex Technology website. For details, please visit the Silex Technology website.

- \* Latest firmware download
- \* Latest software download
- \* Latest manual download
- \* Support information (FAQ)

URL	
USA	<a href="http://www.silexamerica.com/">http://www.silexamerica.com/</a>
Europe	<a href="http://www.silexeurope.com/">http://www.silexeurope.com/</a>
Japan	<a href="http://www.silex.jp/">http://www.silex.jp/</a>

---

## Customer Support Center

---

Customer Support is available by e-mail or telephone for any problems that you may encounter. If you cannot find the relevant problem in this manual or on our website, or if the corrective procedure does not resolve the problem, please contact Silex Technology Customer Support.

<b>Contact Information</b>		
USA	+1-801-748-1199	support@silexamerica.com
Europe	+49-(0)2151-65009-0	support@silexeurope.com
Japan	+81-(0)774-98-3981	support@silex.jp

**Note**

\* Refer to the Silex Technology website (<http://www.silexamerica.com/>) for the latest FAQ and product information.



## 2. About SD-300/SD-320AN

---

## 2-1. Package Contents

---

Following items are bundled:

- \* SD-300 (wired model) / SD-320AN (wireless model)
- \* AC adaptor
- \* Rubber foot (4pcs)
- \* Setup Guide
- \* Warranty Booklet
- \* GPL License Notice  
(Distribution of source code subject to open source software)

## 2-2. Features

SD-300/SD-320AN is a serial device server which allows you to connect to serial devices via wired or wireless LAN.

SD-300/SD-320AN has the following features:

\* **Share various serial devices**

By using SD-300/SD-320AN and the serial device connection utility, "SX Virtual Link for Serial Device Server", you can share various serial devices among Windows PCs (for details on the supported OS, refer to **2-6. Software Specifications**). Serial devices can be used as if they were connected directly to your PC.

\* **Support various applications**

In addition to **SX Virtual Link for Serial Device Server**, SD-300/SD-320AN has 2 communication modes as follows to support a wide variety of network environments and operating systems.

**Ecable Mode**

If two SD-300/SD-320AN's are used, you can communicate with serial devices or PCs with no network interface over the network. For details, refer to **6-2. Ecable Mode (Link to the Registered Device)**.

**Raw TCP Connection Mode**

Serial port data can be sent or received transparently over TCP/IP. You can communicate with a serial device using an application that runs on the TCP Socket API. For details, refer to **6-3. Raw TCP Connection Mode (Link to Serial Device Using TCP Raw Port)**.

\* **IEEE802.11a/b/g/n Wireless LAN standard** (SD-320AN only)

SD-320AN supports the IEEE802.11a/b/g/n which allows sharing of various serial devices over a wireless network.

For authentication method, WEP, WPA(PSK) and WPA2(PSK) can be selected, and 128 bit for WEP, AUTO for WPA and AES for WPA2 can be selected respectively as encryption method. Also, as the IEEE802.1X is supported, EAP-TLS/EAP-TTLS/EAP-LEAP/EAP-PEAP(v0,v1)/EAP-FAST can be used.

\* **Access Point Feature** (SD-320AN only)

Various wireless devices can be used over a wireless network using the Access Point feature of SD-320AN.



\* To connect to a wireless network using the Access Point feature of SD-320AN, the same wireless setting needs to be configured to SD-320AN and your wireless client device.

**Note**

\* **Easy Wireless Configuration** (SD-320AN only)

Wireless configuration using the push button or PIN code is available to configure SD-320AN when your wireless router supports WPS.

## 2-3. Parts and Functions

### Parts and Functions

The parts name and functions are as follows:

<<Front>>

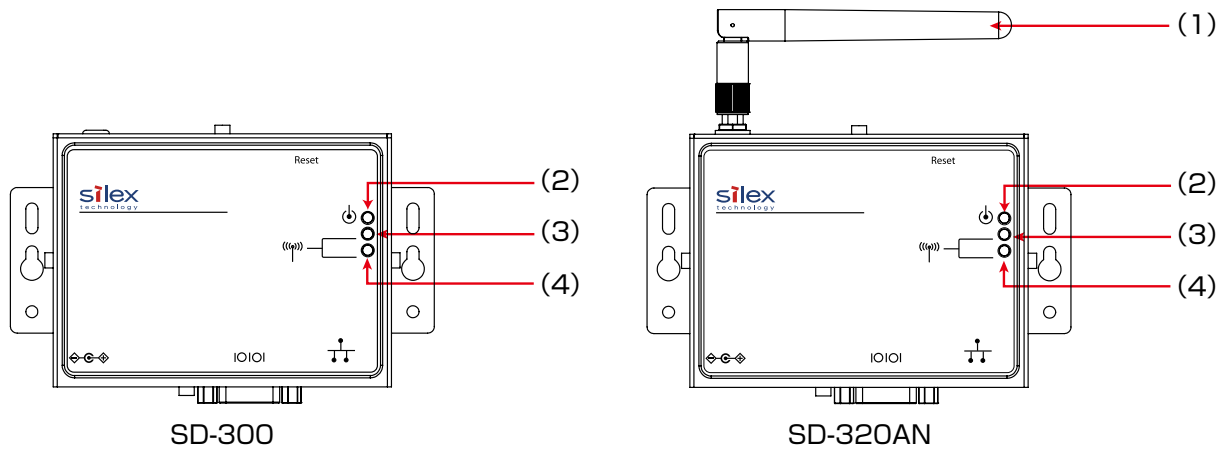

(1)	Wireless LAN antenna (SD-320AN only)	This antenna is used for a wireless communication.
(2)	Orange LED	For details, refer to <b>2-4. LED Lighting Pattern.</b>
(3)	Yellow LED	
(4)	Green LED	

<<Top>>

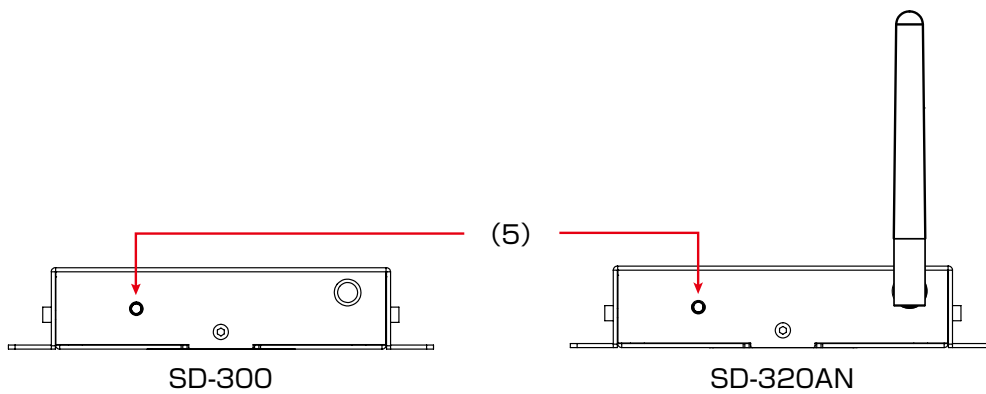

(5)	Push Switch	This push switch is used to reset to the factory defaults. For details on the factory default configuration, refer to <b>Reset to Factory Default</b> .
-----	-------------	---

<<Bottom>>

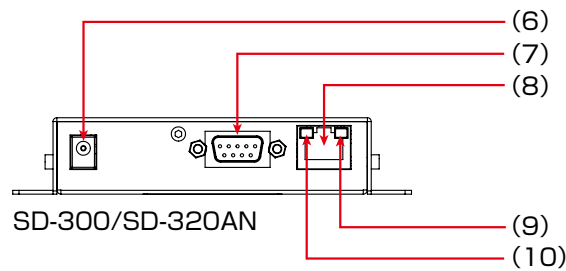

(6)	AC Connector	Connect an AC adaptor.
(7)	Serial Port	Connect a serial cable.
(8)	Network Port	Connect a network cable.
(9)	Yellow LED	Indicates the network connection status. For details, refer to <b>2-4. LED Lighting Pattern</b> .
(10)	Green LED	

<<Back>>

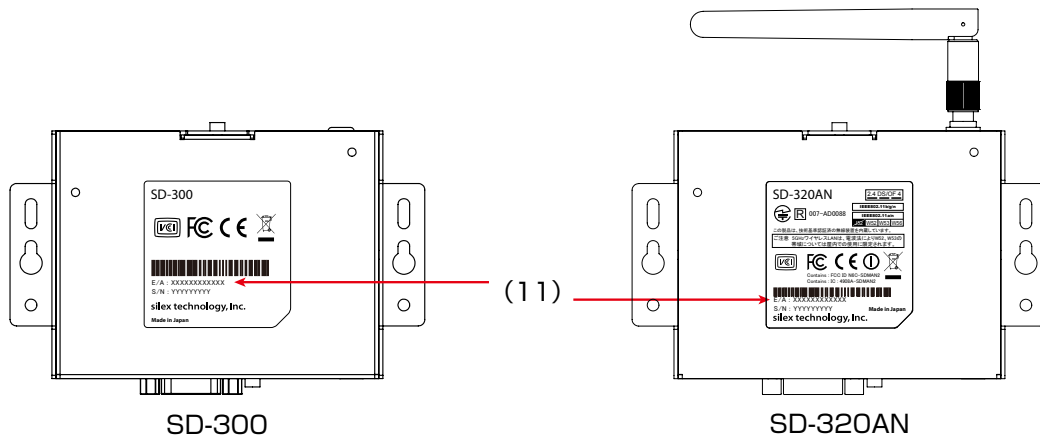

(11)	Ethernet Address	Ethernet Address of SD-300/SD-320AN
------	------------------	-------------------------------------

The serial port PIN assignment is as follows:

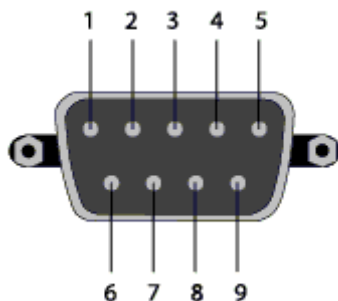

PIN No.	Details	Input / Output
1	DCD(Data Carrier Direct)	Input
2	RxD(Receive Data)	Input
3	TxD(Transmit Data)	Output
4	DTR(Data Terminal Ready)	Output
5	GND(Ground)	Input
6	DSR(Data Set Ready)	Input
7	RTS(Request To Send)	Output
8	CTS(Clear To Send)	Input
9	RI(Ring Indicate) / 5V in	Input

Use the serial cable that came with your serial device (the one you may have been using to directly connect the PC and serial device) or that is recommended in the operating manual of your serial device.

## 2-4. LED Lighting Pattern

SD-300/SD-320AN has 3 LEDs (Orange, Yellow, Green) to show the operating status.

<<FRONT>>

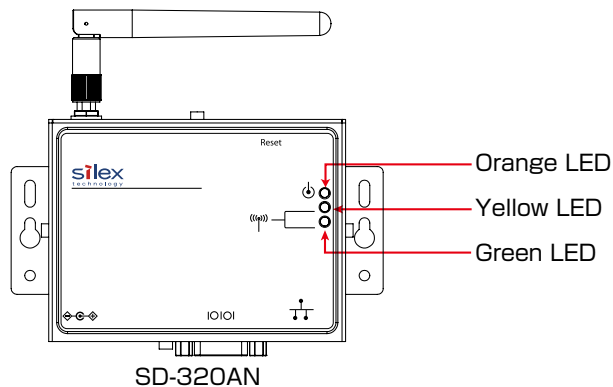
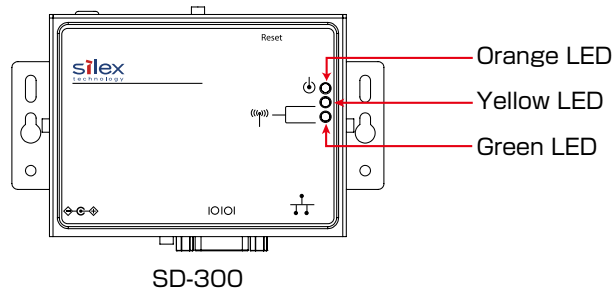

Orange LED	Product Status
ON	SD-300/SD-320AN is powered on
OFF	SD-300/SD-320AN is not powered on
Blink	Updating the firmware

Yellow / Green LED		Product Status
Yellow LED	Green LED	
OFF	OFF	Operating in a wired LAN mode (both SD-300/SD-320AN)
OFF	ON	Connected to Access Point in Infrastructure mode (Authentication is not completed) (SD-320AN only)
Blink	OFF	Connected to Access Point in Infrastructure mode (Trying to obtain an IP address) (SD-320AN only)
ON	OFF	Connected to Access Point in Infrastructure mode (IP address is determined) (SD-320AN only)
ON	ON	Connected in Raw TCP mode (SD-320AN only)
OFF	Blink	Operating in AccessPoint mode (SD-320AN only)

<<BOTTOM>>

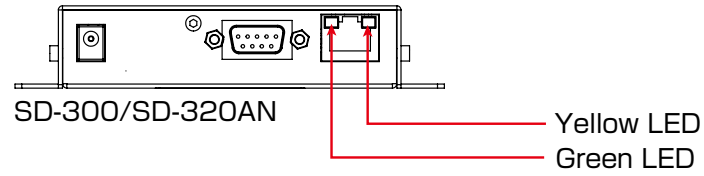

Yellow / Green LED		Product Status
Yellow LED	Green LED	
OFF	OFF	A network cable is not connected
OFF	ON	Connected in 10BASE -T network
ON	ON	Connected in 100BASE -TX network

## 2-5. Hardware Specifications

### SD-300/SD-320AN

CPU	32bit RISC CPU		
Memory	RAM : 64MByte		
	FlashROM : 8MByte		
Wired network interface	10BASE-T / 100BASE-TX 1 port (auto-sensing)		
Serial Interface	RS-232C : 1 port		
Power supply	Operating voltage : 5V		
Push Switch	1 button		
LED	Front	3	Orange LED Yellow LED Green LED
	Wired LAN connector	2	Yellow LED Green LED
Operating environment	Temperature : 0°C to +50°C		
	Humidity : 20% to 80%RH (Non-condensing)		
Storage environment	Temperature : -20°C to +70°C		
	Humidity : 20% to 90%RH (Non-condensing)		
EMI	VCCI Class B / FCC Class B / ICES Class B / CE		

**SD-320AN**

Wireless network interface (*Wireless model only)	IEEE802.11a	Bandwidth	5GHz
		Transmission system	OFDM
		Transmission speed	6M / 9M / 12M / 18M / 24M / 36M / 48M / 54M (auto-sensing)
		Channel	[US] W52 / W53 / W56(excluding 120-128 channels) / W58 [EU / JP] W52 / W53 / W56  * When the Access Point feature is used, W53 and W56 channels cannot be used.
	IEEE802.11b	Bandwidth	2.4GHz
		Transmission system	DS-SS
		Transmission speed	1M / 2M / 5.5M / 11M (auto-sensing)
		Channel	US:1-11ch / EU:1-13ch / JP:1-13ch
	IEEE802.11g	Bandwidth	2.4GHz
		Transmission system	OFDM
		Transmission speed	6M / 9M / 12M / 18M / 24M / 36M / 48M / 54M (auto-sensing)
		Channel	US:1-11ch / EU:1-13ch / JP:1-13ch
	IEEE802.11ng HT20	Bandwidth	2.4GHz
		Transmission system	DSSS-OFDM
		Transmission speed	MCS 0/1/2/3/4/5/6/7
		Channel	US:1-11ch / EU:1-13ch / JP:1-13ch
IEEE802.11na HT20 / HT40	Bandwidth	5GHz	
	Transmission system	OFDM	
	Transmission speed	MCS 0/1/2/3/4/5/6/7	
	Channel	[US] W52 / W53 / W56(excluding 120-128 channels) / W58 [EU / JP] W52 / W53 / W56  * When the Access Point feature is used, W53 and W56 channels cannot be used.	
Antenna (*Wireless model only)	Non-directional antenna		

## FCC / IC Notice (SD-300)



Note: This equipment has been tested and found to comply with the limits for a Class B digital device, pursuant to part 15 of the FCC Rules. These limits are designed to provide reasonable protection against harmful interference in a residential installation. This equipment generates, uses and can radiate radio frequency energy and, if not installed and used in accordance with the instructions, may cause harmful interference to radio communications. However, there is no guarantee that interference will not occur in a particular installation. If this equipment does cause harmful interference to radio or television reception, which can be determined by turning the equipment off and on, the user is encouraged to try to correct the interference by one or more of the following measures:

- Reorient or relocate the receiving antenna.
- Increase the separation between the equipment and receiver.
- Connect the equipment into an outlet on a circuit different from that to which the receiver is connected.
- Consult the dealer or an experienced radio/TV technician for help.

This device complies with part 15 of FCC Rules and Industry Canada's licence-exempt RSSs. Operation is subject to the following two conditions: (1) this device may not cause harmful interference, and (2) this device must accept any interference received, including interference that may cause undesired operation.

Le présent appareil est conforme à la partie 15 des règles de la FCC et aux normes des CNR d'Industrie Canada applicables aux appareils radio exempts de licence. L'exploitation est autorisée aux deux conditions suivantes : (1) l'appareil ne doit pas produire de brouillage, et (2) l'appareil doit accepter tout brouillage subi, même si le brouillage est susceptible d'en compromettre le fonctionnement.

## FCC / IC Notice (SD-320AN)



**FCCID : N6C-SDMAN2**

**IC : 4908A-SDMAN2**

### **Channel Selection**

For product available in the USA/Canada market, only channel 1~11 can be operated. Selection of other channels is not possible.

### **Fcc Rules Part 15**

#### **FCC CAUTION**

Changes or modifications not expressly approved by the party responsible for compliance could void the user's authority to operate the equipment.

#### **FCC Rules, Part 15 §15.19(a)(3) / IC RSS Gen §8.4**

Below sentences must be indicated on the final product which contains this module inside.

This device complies with Part 15 of FCC Rules and Industry Canada licence-exempt RSS standard(s). Operation is subject to the following two conditions: (1) this device may not cause interference, and (2) this device must accept any interference, including interference that may cause undesired operation of this device.

Le présent appareil est conforme à la partie 15 des règles de la FCC et CNR d'Industrie Canada applicables aux appareils radio exempts de licence. L'exploitation est autorisée aux deux conditions suivantes : (1) l'appareil ne doit pas produire de brouillage, et (2) l'appareil doit accepter tout brouillage subi, même si le brouillage est susceptible d'en compromettre le fonctionnement.

#### **FCC Rules Part 15 Subpart C §15.247 and Subpart E / IC RSS-102 §2.6**

This equipment complies with FCC/IC radiation exposure limits set forth for an uncontrolled environment and meets the FCC radio frequency (RF) Exposure Guidelines and RSS-102 of the IC radio frequency (RF) Exposure rules. This equipment should be installed and operated keeping the radiator at least 20cm or more away from person's body.

Cet équipement est conforme aux limites d'exposition aux rayonnements énoncées pour un environnement non contrôlé et respecte les règles les radioélectriques (RF) de la FCC lignes directrices d'exposition et d'exposition aux fréquences radioélectriques (RF) CNR-102 de l'IC. Cet équipement doit être installé et utilisé en gardant une distance de 20 cm ou plus entre le radiateur et le corps humain.

### **FCC Rules Part 15 Subpart E §15.407(c)**

Compliance with FCC requirement 15.407(c)

Data transmission is always initiated by software, which is then passed down through the MAC, through the digital and analog baseband, and finally to the RF chip. Several special packets are initiated by the MAC. These are the only ways the digital baseband portion will turn on the RF transmitter, which it then turns off at the end of the packet. Therefore, the transmitter will be on only while one of the aforementioned packets is being transmitted.

In other words, this device automatically discontinues transmission in case of either absence of information to transmit or operational failure.

### **FCC Rules Part 15 Subpart E §15.407(g)**

Frequency Tolerance: +/-20 ppm

### **FCC Rules Part 15 Subpart C §15.247(g) / Subpart E**

This device and its antenna(s) must not be co-located or operation in conjunction with any other antenna or transmitter.

### **RSS-Gen §8.3**

This radio transmitter 4908A-SDMAN2 has been approved by Industry Canada to operate with the antenna types listed below with the maximum permissible gain and required antenna impedance for each antenna type indicated. Antenna types not included in this list, having a gain greater than the maximum gain indicated for that type, are strictly prohibited for use with this device.

Le numéro IC du présent émetteur radio 4908A-SDMAN2 a été approuvé par Industrie Canada pour fonctionner avec les types d'antenne énumérés ci-dessous et ayant un gain admissible maximal et l'impédance requise pour chaque type d'antenne. Les types d'antenne non inclus dans cette liste, ou dont le gain est supérieur au gain maximal indiqué pour ce type, sont strictement interdits pour l'exploitation avec cet appareil.

- Antenna type

Non-directional antenna

- Model

H2B1PC1A1C

- Antenna Gain

2.4GHz : +1.8dBi (Peak)

5GHz : +3.9 dBi (Peak)

**RSS-210**

5150-5250 MHz and 5250-5350 MHz bands are restricted to indoor operations only. High-power radars are allocated as primary users (i.e. priority users) of the bands 5250-5350 MHz and 5650-5850 MHz and that these radars could cause interference and/or damage to LE-LAN devices.

La bandes 5150-5250 MHz et 5250-5350 MHz ont restreinte à une utilisation à l'intérieur seulement.

Les radars de haute puissance sont désignés comme utilisateurs principaux (c'est-à dire utilisateurs prioritaires) pour les bandes 5250-5350 MHz et 5650-5850 MHz, et que ces radars peuvent provoquer du brouillage et/ou des dommages aux dispositifs LAN-EL.

**WARNING**

The FCC / The Industry Canada regulations provide that changes or modifications not expressly approved by the party responsible for compliance could void the user's authority to operate the equipment.

**CE Notice**

SD-300 : 

SD-320AN : 

## 2-6. Software Specifications

### Software Specifications

Supported protocols		TCP/IP
		DHCP, BOOTP, TCP, UDP, ARP, ICMP, IPv4, SNMP, TELNET, HTTP, #3001, #9100, #9200, JCP(silex proprietary protocol), SXSPE(silex proprietary protocol)
Supported OS		Windows 2000 SP4 or newer Windows XP SP2 or newer ( 32-Bit Edition / 64-Bit Edition ) Windows Vista SP1 or newer ( 32-Bit Edition / 64-Bit Edition ) Windows Server 2003 SP2 or newer ( 32-Bit Edition / 64-Bit Edition ) Windows Server 2008 SP1 or newer ( 32-Bit Edition / 64-Bit Edition ) Windows 7 ( 32-Bit Edition / 64-Bit Edition ) Windows 8 ( 32-Bit Edition / 64-Bit Edition ) Windows 8.1 ( 32-Bit Edition / 64-Bit Edition )
Serial port	Baud rate	300, 600, 1200, 2400, 4800, 9600, 19200, 38400, 57600, 115200, 230400, 460800, 921600 (bps)  * The baud rate higher than 115200bps is not guaranteed.
	Bits per character	7, 8
	Stop bit	1, 2
	Parity	NONE, ODD, EVEN
	Flow control	NONE, XON/XOFF, RTS/CTS
Wireless LAN (*Wireless model only)	Authentication method	Open System, WPA-PSK, WPA2-PSK, WPA-EAP(TLS, TTLS, LEAP, PEAP(v0,v1), FAST),WPA2-EAP(TLS, TTLS, LEAP, PEAP(v0,v1), FAST)
	Encryption mode	WEP(128bit), AUTO(TKIP/AES), AES
Others		RFC2217 support (see below for details)

## RFC2217 Command List

SD-300/SD-320AN supports RFC2217. When SD-300/SD-320AN is used in Serial Port Emulation Mode, you can utilize the following RFC2217 commands over the network.

Command	Details	Note
SIGNATURE	Exchanges the device information.	Not supported
SET-BAUDRATE	Changes the baud rate.	Client -> Server (one-way)
SET-DATASIZE	Change the bits per character.	Client -> Server (one-way)
SET-PARITY	Changes the parity.	Client -> Server (one-way)
SET-STOPSIZE	Changes the stop bit.	Client -> Server (one-way)
SET-CONTROL	Enables/Disables the flow control or use for PIN setting.	Client -> Server (one-way)
NOTIFY-LINESTATE	Server notifies the client of line status changes.	* Client -> Server (one-way)
NOTIFY-MODEMSTATE	Server notifies the client of modem status changes.	Client -> Server (one-way)
FLOWCONTROL-SUSPEND	The receiver of this command will be unable to send any data or commands.	Client <-> Server (bidirectional)
FLOWCONTROL-RESUME	The receiver of this command will be able to send data and commands.	Client <-> Server (bidirectional)
SET-LINESTATE-MASK	Set the information to send by NOTIFY-LINESTATE.	Client -> Server (one-way)
SET-MODEMSTATE-MASK	Set the information to send by NOTIFY-MODEMSTATE.	Client -> Server (one-way)
PURGE-DATA	Requests the server to clear the serial buffer.	Client -> Server (one-way)

## 2-7. Wireless Interference Information

### Notes

#### **Do not use SD-300/SD-320AN near the following devices or places.**

The following equipment may use the same band. If you use this product near this equipment, the radio waves from SD-300/SD-320AN and the following devices may interfere with each other.

- \* Microwave, pacemaker, etc. of industrial, scientific and medical devices
- \* Licensed radio station in a factory
- \* Small power radio station (A non-licensed radio station)

#### **Do not use SD-300/SD-320AN near a cellular phone, TV or Radio.**

A cellular phone, TV, and radio use a different radio band than our product. Generally if they are used near SD-300/SD-320AN, it will not cause a problem. However, when they approximate SD-300/SD-320AN, sound or image noise can happen.



#### **If there is reinforced concrete/metal between wireless devices, they may not connect.**



SD-300/SD-320AN can connect through wood or glass, but may have troubles connecting through reinforced concrete/metal.

### **Wireless Equipment for 2.4GHz band**

This band of equipment is used by a microwave, industry, science, medical equipment and licensed in room or low power (non licensed) radio stations.

- \* Before you use this equipment, verify that it will not interfere with other broadcasting.
- \* If interference happens, stop using the equipment or change the band. Contact us to discuss ways of avoiding interference (example: create the wall).

2.4	DS/OF	4
		

2.4	: Wireless devices using 2.4GHz frequency band
DS/OF	: DS-SS or OFDM is used as modulation.
4	: The range of interference is equal to or lower than 40m.
  	: All bands can be used to avoid interference.

**Notes on using 5GHz band**

Use of 5.2GHz band (W52) and 5.3GHz band (W53) outdoors is prohibited by the radio law. Be sure to use only W56 channel and not to use W52/W53 channels outdoors.

## 2-8. Notes on Security

---

Because a wireless LAN uses electromagnetic signals instead of a network cable to establish communication with network devices, it has the advantage of allowing devices to connect to the network easily. However, a disadvantage of this is that within a certain range, the electromagnetic signals can pass through barriers such as walls, and if security countermeasures are not implemented in some way, problems such as the following may occur.

- \* Communication is intercepted by a third party
- \* Unauthorized access to the network
- \* Leakage of personal information (ID and Card information)
- \* Spoofing and the falsification of intercepted data
- \* System crashes and data corruption

Nowadays, wireless LAN cards or access points are equipped with security measures that address such security problems, so that you can enable security-related settings for wireless LAN products in order to reduce the likelihood of problems occurring.

We recommend that you make yourself fully acquainted with the possible implications of what might happen if you use a wireless product without enabling security features, and that you configure security-related settings and use wireless products at your own responsibility.

## 2-9. About OpenSSL License

---

This product includes software developed by the OpenSSL Project for use in the OpenSSL Toolkit.

( <http://www.openssl.org/> )

OpenSSL License

-----

/\* =====

\* Copyright (c) 1998-2016 The OpenSSL Project. All rights reserved.

\*

\* Redistribution and use in source and binary forms, with or without  
\* modification, are permitted provided that the following conditions  
\* are met:

\*

\* 1. Redistributions of source code must retain the above copyright  
\* notice, this list of conditions and the following disclaimer.

\*

\* 2. Redistributions in binary form must reproduce the above copyright  
\* notice, this list of conditions and the following disclaimer in  
\* the documentation and/or other materials provided with the  
\* distribution.

\*

\* 3. All advertising materials mentioning features or use of this  
\* software must display the following acknowledgment:  
\* "This product includes software developed by the OpenSSL Project  
\* for use in the OpenSSL Toolkit. (<http://www.openssl.org/>)"

\*

\* 4. The names "OpenSSL Toolkit" and "OpenSSL Project" must not be used to  
\* endorse or promote products derived from this software without  
\* prior written permission. For written permission, please contact  
\* [openssl-core@openssl.org](mailto:openssl-core@openssl.org).

\*

\* 5. Products derived from this software may not be called "OpenSSL"  
\* nor may "OpenSSL" appear in their names without prior written  
\* permission of the OpenSSL Project.

\*

\* 6. Redistributions of any form whatsoever must retain the following  
\* acknowledgment:

```
* "This product includes software developed by the OpenSSL Project
* for use in the OpenSSL Toolkit (http://www.openssl.org/)"
*
* THIS SOFTWARE IS PROVIDED BY THE OpenSSL PROJECT "AS IS" AND ANY
* EXPRESSED OR IMPLIED WARRANTIES, INCLUDING, BUT NOT LIMITED TO, THE
* IMPLIED WARRANTIES OF MERCHANTABILITY AND FITNESS FOR A PARTICULAR
* PURPOSE ARE DISCLAIMED. IN NO EVENT SHALL THE OpenSSL PROJECT OR
* ITS CONTRIBUTORS BE LIABLE FOR ANY DIRECT, INDIRECT, INCIDENTAL,
* SPECIAL, EXEMPLARY, OR CONSEQUENTIAL DAMAGES (INCLUDING, BUT
* NOT LIMITED TO, PROCUREMENT OF SUBSTITUTE GOODS OR SERVICES;
* LOSS OF USE, DATA, OR PROFITS; OR BUSINESS INTERRUPTION)
* HOWEVER CAUSED AND ON ANY THEORY OF LIABILITY, WHETHER IN CONTRACT,
* STRICT LIABILITY, OR TORT (INCLUDING NEGLIGENCE OR OTHERWISE)
* ARISING IN ANY WAY OUT OF THE USE OF THIS SOFTWARE, EVEN IF ADVISED
* OF THE POSSIBILITY OF SUCH DAMAGE.
* =====
*
* This product includes cryptographic software written by Eric Young
* (eay@cryptsoft.com). This product includes software written by Tim
* Hudson (tjh@cryptsoft.com).
*
*/
```

Original SSLeay License

-----

```
/* Copyright (C) 1995-1998 Eric Young (eay@cryptsoft.com)
* All rights reserved.
*
* This package is an SSL implementation written
* by Eric Young (eay@cryptsoft.com).
* The implementation was written so as to conform with Netscapes SSL.
*
* This library is free for commercial and non-commercial use as long as
* the following conditions are aheared to. The following conditions
* apply to all code found in this distribution, be it the RC4, RSA,
* lhash, DES, etc., code; not just the SSL code. The SSL documentation
* included with this distribution is covered by the same copyright terms
* except that the holder is Tim Hudson (tjh@cryptsoft.com).
*
* Copyright remains Eric Young's, and as such any Copyright notices in
* the code are not to be removed.
```

- \* If this package is used in a product, Eric Young should be given attribution
- \* as the author of the parts of the library used.
- \* This can be in the form of a textual message at program startup or
- \* in documentation (online or textual) provided with the package.
- \*
- \* Redistribution and use in source and binary forms, with or without
- \* modification, are permitted provided that the following conditions
- \* are met:
- \* 1. Redistributions of source code must retain the copyright
- \* notice, this list of conditions and the following disclaimer.
- \* 2. Redistributions in binary form must reproduce the above copyright
- \* notice, this list of conditions and the following disclaimer in the
- \* documentation and/or other materials provided with the distribution.
- \* 3. All advertising materials mentioning features or use of this software
- \* must display the following acknowledgement:
- \* "This product includes cryptographic software written by
- \* Eric Young (eay@cryptsoft.com)"
- \* The word 'cryptographic' can be left out if the routines from the library
- \* being used are not cryptographic related :-).
- \* 4. If you include any Windows specific code (or a derivative thereof) from
- \* the apps directory (application code) you must include an acknowledgement:
- \* "This product includes software written by Tim Hudson (tjh@cryptsoft.com)"
- \*
- \* THIS SOFTWARE IS PROVIDED BY ERIC YOUNG "AS IS" AND
- \* ANY EXPRESS OR IMPLIED WARRANTIES, INCLUDING, BUT NOT LIMITED TO, THE
- \* IMPLIED WARRANTIES OF MERCHANTABILITY AND FITNESS FOR A PARTICULAR PURPOSE
- \* ARE DISCLAIMED. IN NO EVENT SHALL THE AUTHOR OR CONTRIBUTORS BE LIABLE
- \* FOR ANY DIRECT, INDIRECT, INCIDENTAL, SPECIAL, EXEMPLARY, OR CONSEQUENTIAL
- \* DAMAGES (INCLUDING, BUT NOT LIMITED TO, PROCUREMENT OF SUBSTITUTE GOODS
- \* OR SERVICES; LOSS OF USE, DATA, OR PROFITS; OR BUSINESS INTERRUPTION)
- \* HOWEVER CAUSED AND ON ANY THEORY OF LIABILITY, WHETHER IN CONTRACT, STRICT
- \* LIABILITY, OR TORT (INCLUDING NEGLIGENCE OR OTHERWISE) ARISING IN ANY WAY
- \* OUT OF THE USE OF THIS SOFTWARE, EVEN IF ADVISED OF THE POSSIBILITY OF
- \* SUCH DAMAGE.
- \*
- \* The licence and distribution terms for any publicly available version or
- \* derivative of this code cannot be changed. i.e. this code cannot simply be
- \* copied and put under another distribution licence
- \* [including the GNU Public Licence.]
- \*/

# 3. Software Overview

---

## 3-1. What is Serial Device Server Setup?

The Serial Device Server Setup is the configuration utility exclusively designed for serial device servers. TCP/IP settings, wireless LAN settings, etc. can be configured by following the instructions on the screen after SD-300/SD-320AN is powered on and displayed on this utility.

### Select Configuration Method

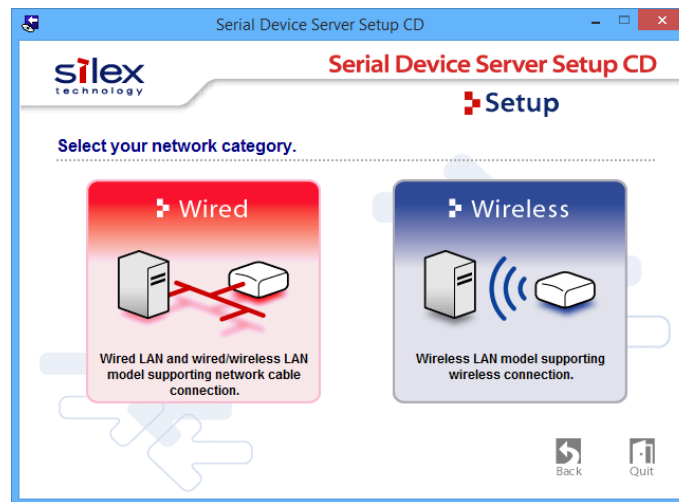

Wired	Connect a network cable to SD-300/SD-320AN and start the initial configuration from a PC.
Wireless	Start the initial configuration from a PC over the wireless network.



\* SD-320AN does not support the configuration over a wireless LAN by clicking **Wireless**.

## TCP/IP Settings

Configure the IP address appropriate for your environment.

Serial Device Server Setup

Setting TCP/IP  
Setting TCP/IP will proceed.

Get IP Address Automatically

Assign IP Address

IP Address: 169 . 254 . 111 . 111

Subnet Mask: 255 . 255 . 0 . 0

Default Gateway: 0 . 0 . 0 . 0

MEMO  
If you select [Get IP Address Automatically], the DHCP server assigns an IP address to this product. If a DHCP server is not available, please manually assign an IP address.

< Back Next > Cancel

Get IP Address Automatically	Select this to automatically assign an IP Address using the DHCP server.
Assign IP Address	Select this to manually configure IP Address, subnet mask and default gateway.



**TIP**

- \* Enter a Subnet Mask and Default Gateway if necessary.
- \* If there are no DHCP servers on your network and the IP address of your computer is assigned manually, a sample address created with your computer's settings will be displayed in the window below. In such a case, please enter an IP address manually. The IP address used in the screen below is a sample address. Please specify an IP address appropriate for your environment.

Serial Device Server Setup

Setting TCP/IP  
Setting TCP/IP will proceed.

Get IP Address Automatically

Assign IP Address

IP Address: 169 . 254 . 111 . 111

Subnet Mask: 255 . 255 . 0 . 0

Default Gateway: 0 . 0 . 0 . 0

MEMO  
If you select [Get IP Address Automatically], the DHCP server assigns an IP address to this product. If a DHCP server is not available, please manually assign an IP address.

< Back Next > Cancel

## Wireless LAN Settings (only for SD-320AN)

Configure the wireless LAN settings appropriate for your environment.

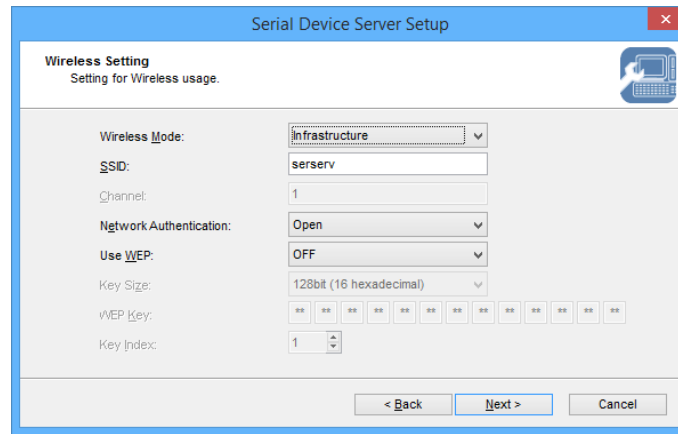

The screenshot shows a window titled "Serial Device Server Setup" with a sub-section "Wireless Setting" and the instruction "Setting for Wireless usage." The settings are as follows:

Wireless Mode:	Infrastructure
SSID:	ser serv
Channel:	1
Network Authentication:	Open
Use WEP:	OFF
Key Size:	128bit (16 hexadecimal)
WEP Key:	16 hexadecimal characters
Key Index:	1

At the bottom of the dialog are three buttons: "< Back", "Next >", and "Cancel".

## 3-2. What is SX Virtual Link for Serial Device Server?

### About SX Virtual Link for Serial Device Server

SX Virtual Link for Serial Device Server allows you to connect your computer to a serial device that is connected to a device server.

Use SX Virtual Link for Serial Device Server when you connect/disconnect to/from the serial device.

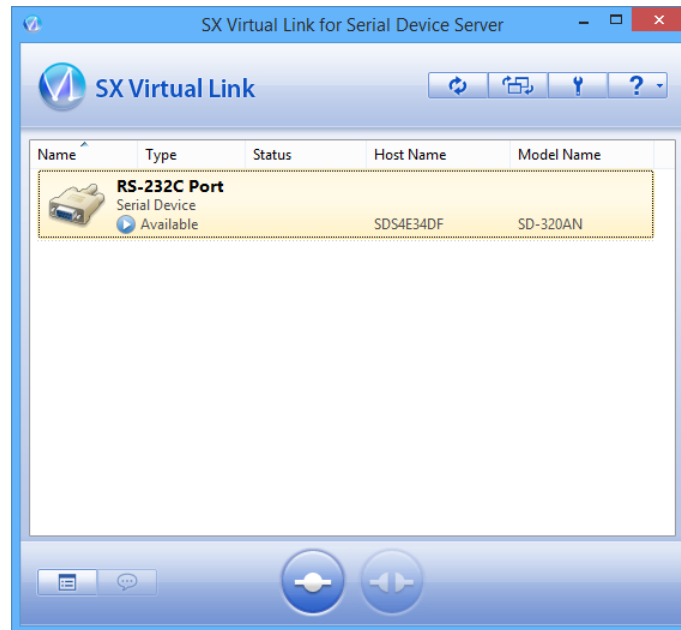

## Functional Overview

---

### \* **Easy to Use**

You only have to select the serial device in SX Virtual Link for Serial Device Server and click the **Connect** button.

The serial device can be used from your computer as if it was directly connected to your computer. When finished using the serial device, click the **Disconnect** button in SX Virtual Link for Serial Device Server.

### \* **Printer Auto Connection**

When you print to a serial printer, SX Virtual Link for Serial Device Server will automatically connect your computer to the printer. When the print job is complete, SX Virtual Link for Serial Device Server will disconnect your computer from the serial printer. Thus, you will not have to manually connect/disconnect to/from the serial printer using SX Virtual Link for Serial Device Server.



\* Depending on the printing capability of the serial device, the Printer auto connection feature may not work properly.

### \* **Allows Control from the Task tray**

The minimized menu window in the task tray will allow you to connect/disconnect to/from serial devices without displaying SX Virtual Link for Serial Device Server's main window.

### \* **Send a Remote Message to Another User to Request for Disconnect**

When you are sharing a serial device with several users and one of them occupies the serial device for a long time, you can request to the user to disconnect the device by sending a remote message. If the user accepts the disconnect request, the right of use is automatically passed down to you, so that you can use the serial device.

### \* **Operating Settings for Each serial Device**

The operational settings such as Start designated application when connected or Automatically connect this device when it is available can be configured for each serial device.

## 3-3. Download the Utilities

The utilities to configure and use SD-300/SD-320AN can be downloaded from our website.

1. Access the URL below on the PC to use to configure SD-300/SD-320AN.

**USA:** <http://www.silexamerica.com>

**Europe:** <http://www.silexeurope.com>

2. Go to the **Support** page and select the product model.

Product Model	SD-300 or SD-320AN
---------------	--------------------

3. Download the utilities below and extract them on the PC.

Utilities	Serial Device Server Setup
	SX Virtual Link for Serial Device Server



\* In order to upgrade the firmware version, the firmware file needs to be downloaded.

### **Note**

The download is completed.





# 4. How to Configure(SD-300)

---

## 4-1. Necessary items for Setup

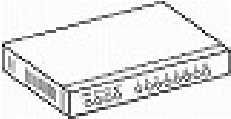
The following items are required in order to connect SD-300 to a network.

<p>Ethernet Hub</p> 	<p>Use to connect SD-300 and other network devices such as a PC. When there are available LAN ports on the network in which SD-300 is to be installed, you do not have to purchase a new Ethernet Hub or broadband router as SD-300 can be connected to the available LAN port.</p>
<p>Network Cable</p> 	<p>Use to connect SD-300 and network devices such as an Ethernet Hub, broadband router and PC.</p>
<p>Serial Cable</p> 	<p>Use to connect SD-300 and serial devices. For details on the supported serial cable, refer to <b>2-3. Parts and Functions - Serial Port PIN Assignment and Serial Cable.</b></p>



\* When you connect SD-300 to 100BASE-TX network, please use the Ethernet Hub and network cable which support 100BASE-TX (category 5 or above).

## 4-2. Power on

1. Connect a network cable to SD-300 and the other end to an Ethernet Hub (or broadband router, Access Point, PC).  
Then, connect the AC adaptor to SD-300 and the plug to the outlet.

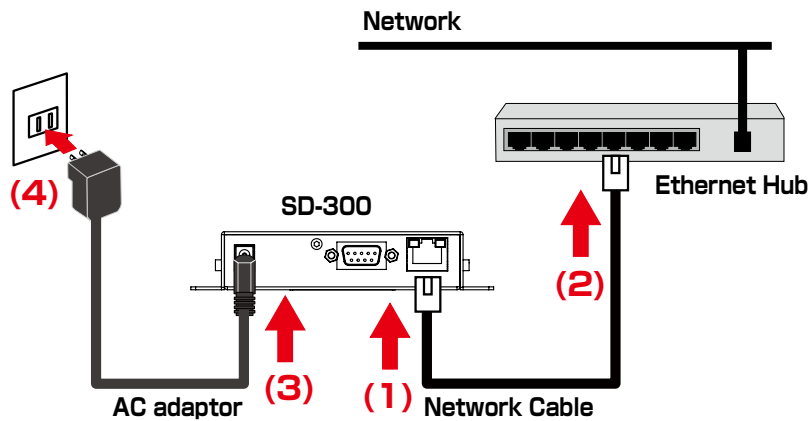

2. Check that the LEDs on SD-300 light as follows.

LED	Status
Orange LED	ON
Green/Yellow LEDs	OFF

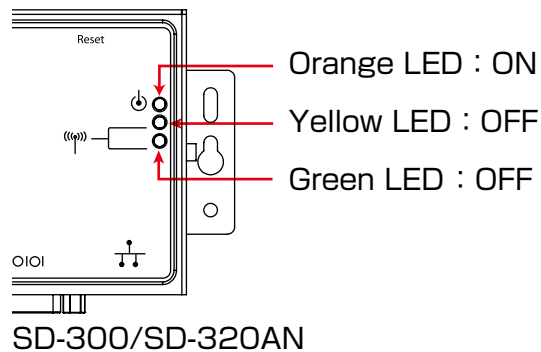

## 4-3. Configure Network Settings

1. Extract the compressed file of **Serial Device Server Setup** that you have downloaded. Double-click **Sdsetup.exe** in the extracted folder to start the Serial Device Server Setup utility.
2. The startup menu is displayed. Click **Device Server Setup**.

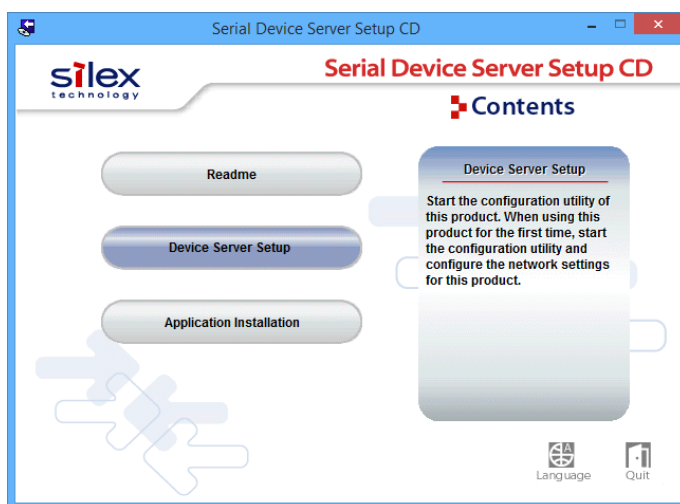

3. Click **Wired**.

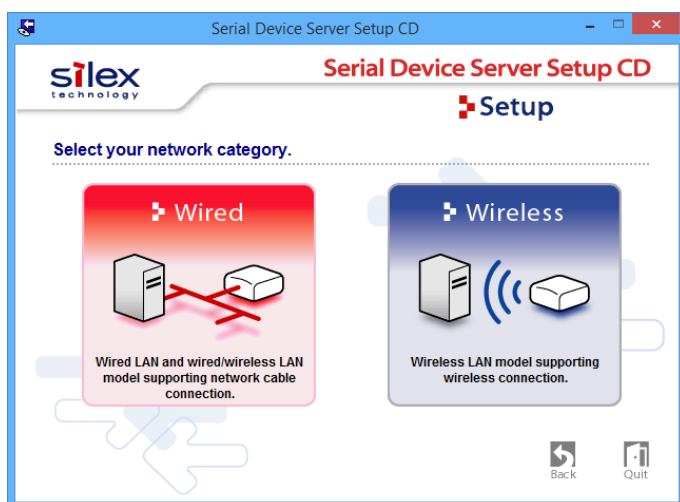



- \* If the User Account Control screen is displayed, click **Continue** or **Yes**.
- \* If the message below is displayed, click **Yes**.

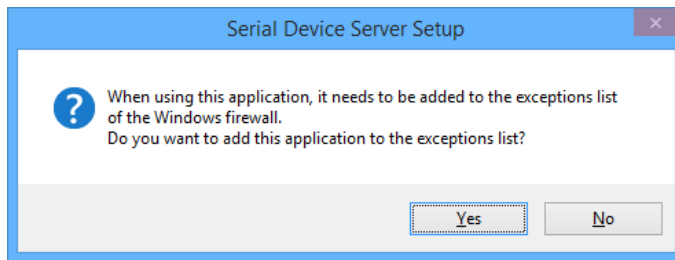

### 4. The Serial Device Server Setup screen is displayed. Click **Next**.



### 5. Read the **SOFTWARE LICENSE AGREEMENT** and click **Yes**.

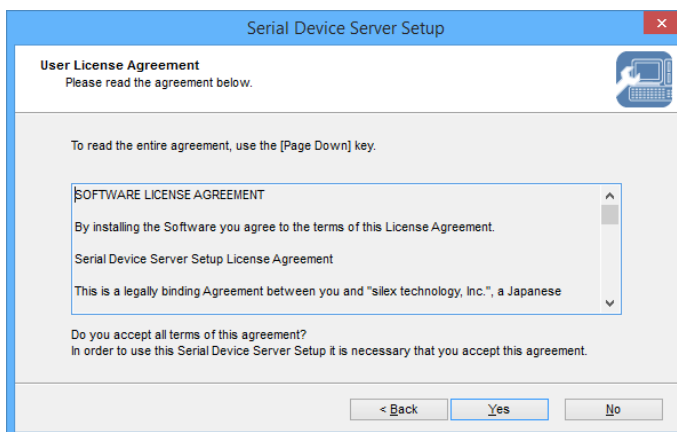

**6. Select SD-300 and click **Next**.**

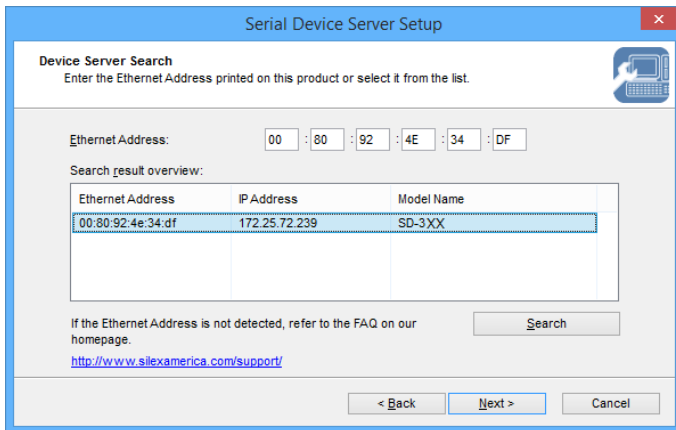

- \* If SD-300 is using the factory default settings and an IP address other than 0.0.0.0 is displayed in the list, it means the IP address was obtained from a DHCP server.
- \* If SD-300 is not displayed on the list, click Search. If this does not help, refer to **SD-300 is not displayed in the search result of Serial Device Server Setup.** in **8-1. Problems During the Setup.**

**7. Configure the TCP/IP settings appropriate for your environment.**



- \* If you are not sure how to determine the IP address to set, refer to **How should I determine the way to assign IP address to SD-300?** in **8-1. Problems During the Setup.**

**<< Obtain an IP address automatically from a DHCP server >>**  
 Select **Get IP Address Automatically** and click **Next**.

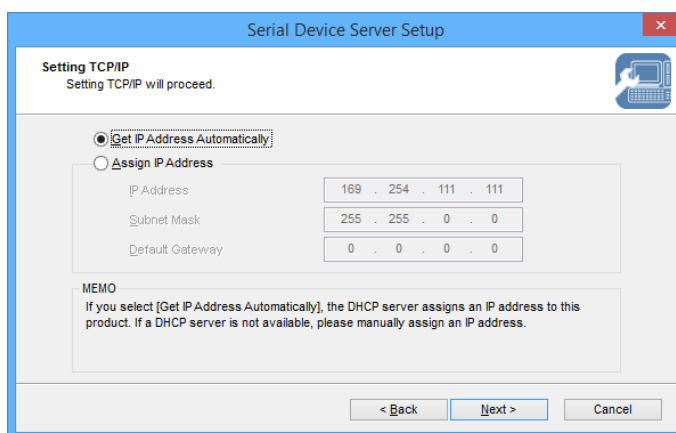

## &lt;&lt; Assign an IP address manually &gt;&gt;

Select **Assign IP Address** and enter an IP address. Click **Next**.

Serial Device Server Setup

Setting TCP/IP  
Setting TCP/IP will proceed.

Get IP Address Automatically  
 **Assign IP Address**

IP Address: 169 . 254 . 111 . 111  
 Subnet Mask: 255 . 255 . 0 . 0  
 Default Gateway: 0 . 0 . 0 . 0

MEMO  
If you select [Get IP Address Automatically], the DHCP server assigns an IP address to this product. If a DHCP server is not available, please manually assign an IP address.

< Back   Next >   Cancel

**TIP**

- \* The IP address used in the screen above is a sample address. Please enter an IP address appropriate for your environment.
- \* Enter a **Subnet Mask** and **Default Gateway** if necessary.
- \* If there are no DHCP servers on your network and the IP address of your PC is assigned manually, the screen below will be displayed. Please configure an IP address appropriate for your environment.

Serial Device Server Setup

Setting TCP/IP  
Setting TCP/IP will proceed.

IP Address: 0 . 0 . 0 . 0  
 Subnet Mask: 0 . 0 . 0 . 0  
 Default Gateway: 0 . 0 . 0 . 0

< Back   Next >   Cancel

**8.** Check the settings and click **Execute**.

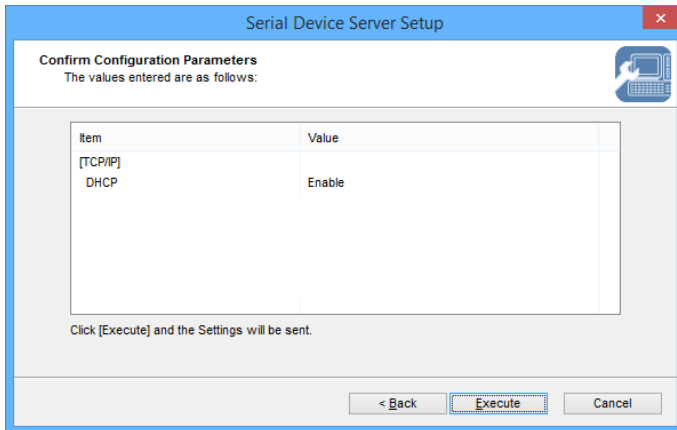

\* The information displayed in this screen will vary depending on the items you have configured.



**Note**

\* If an error occurs after clicking Execute, please refer to **Communication error occurs when configuring with Serial Device Server Setup.** in **8-1. Problems During the Setup.**

**9.** Select **Yes** and click **Finish**.

Continue to install the SX Virtual Link for Serial Device Server. For details on the installation, refer to **Install Application**.

After the installation is finished, go on to **10**.



**Note**

\* When **No** is selected, go on to **10**.

10. Remove the power plug from the outlet.

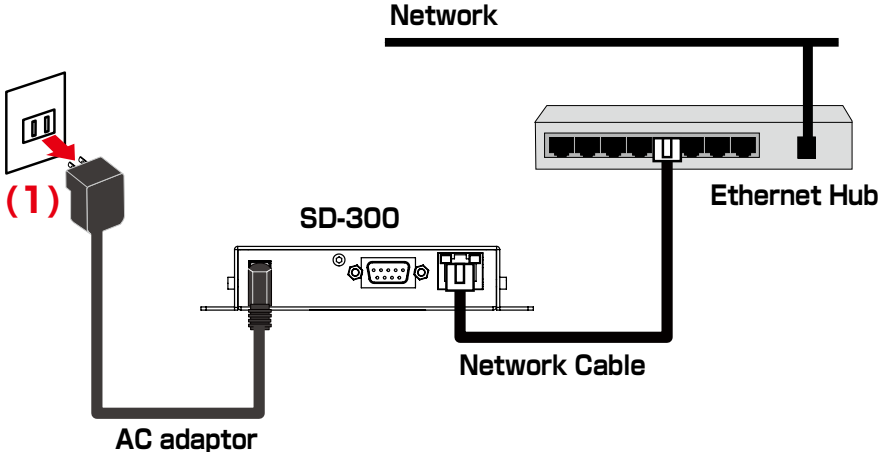

11. Connect the serial device that you wish to share over the network to SD-300 using a serial cable and insert the power plug of SD-300 into the outlet.

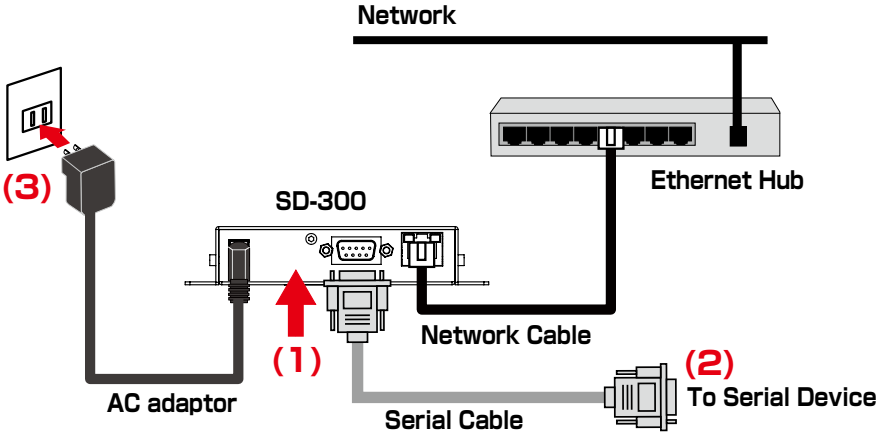

Network configuration is complete.



# 5. How to Configure(SD-320AN)

---

## 5-1. Before Setup

This page explains the preparation and configuration method to be noted before starting the setup.

### Check your wireless LAN settings

To use SD-320AN over wireless LAN network, you need to configure the wireless settings appropriate for your network. This setting must be the same as that of destination devices such as Access Point. Please collect the following information first:

SSID	This name is used to identify the wireless devices. It is also known as ESSID.	
Encryption method	No encryption	Communication data is not encrypted.
	WEP	Communication data is encrypted based on the encryption key (WEP key). <b>WEP key size (128bit)</b> and <b>WEP key</b> must be the same as that of destination device.
	WPA/WPA2	Communication data is encrypted based on the encryption key (Pre-Shared Key). <b>Pre-Shared Key</b> and <b>Encryption mode (AES / AUTO)</b> must be the same as that of destination device.



#### Note

\* When you will use SD-320AN in a wired network, you do not have to collect these information.

## About configuration methods

The following configuration methods are available:

\* **Configure through a wired LAN (Recommended)**

Connect SD-320AN to the network using a network cable and configure from a PC.

\* **Configure using Smart Wireless Setup**

Use the PIN code method or push button method to configure the network settings when the wireless router supports WPS.



Please choose the one appropriate for your environment.



- \* Please be sure to read the operation manual of your serial device before you connect it to SD-320AN. The connecting method and position may vary depending on the serial device to be connected.
- \* Please use the AC adapter bundled with SD-320AN. Other AC adapters may cause unexpected damages.
- \* If SD-320AN has been used in another network, reset it to the factory default settings before you start the configuration. (Please refer to **Reset to Factory Default** for details.
- \* If using a firewall function of commercial security software, disable the firewall function while configuring SD-320AN. Refer to FAQ in our website at ( <http://www.silexamerica.com/> ) for details.

## 5-2. Necessary items for Setup

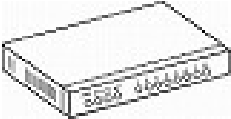
The following items are required in order to connect SD-320AN to a network.

<p>Ethernet Hub</p> 	<p>Use to connect SD-320AN and other network devices such as a PC. When there are available LAN ports on the network in which SD-320AN is to be installed, you do not have to purchase a new Ethernet Hub or broadband router as SD-320AN can be connected to the available LAN port.</p>
<p>Network Cable</p> 	<p>Use to connect SD-320AN and network devices such as an Ethernet Hub, broadband router and PC.</p>
<p>Serial Cable</p> 	<p>Use to connect SD-320AN and serial devices. For details on the supported serial cable, refer to <b>2-3. Parts and Functions - Serial Port PIN Assignment and Serial Cable.</b></p>



\* When you connect SD-320AN to 100BASE-TX network, please use the Ethernet Hub and network cable which support 100BASE-TX (category 5 or above).

## 5-3. Power on

1. Connect a network cable to SD-320AN and the other end to an Ethernet Hub (or broadband router, Access Point, PC).  
Then, connect the AC adaptor to SD-300 and the plug to the outlet.

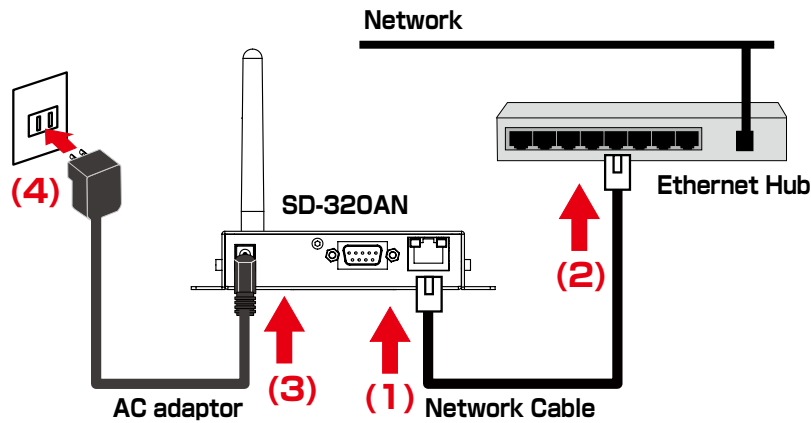

2. Check that the LEDs on SD-320AN light as follows.

LED	Status
Orange LED	ON
Green/Yellow LEDs	OFF

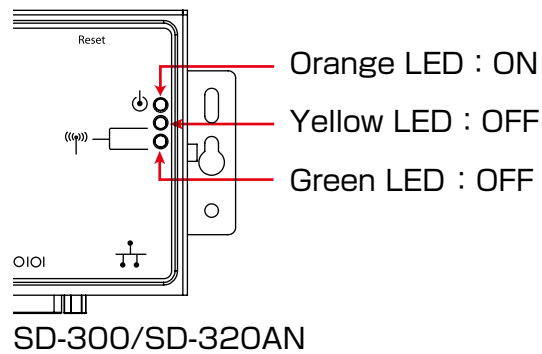

## 5-4. Configure Network Settings

This page explains how to configure SD-320AN from a PC using a network cable.

1. Extract the compressed file of **Serial Device Server Setup** that you have downloaded. Double-click **Sdsetup.exe** in the extracted folder to start the Serial Device Server Setup utility.
2. The startup menu is displayed. Click **Device Server Setup**.



3. Click **Wired**.

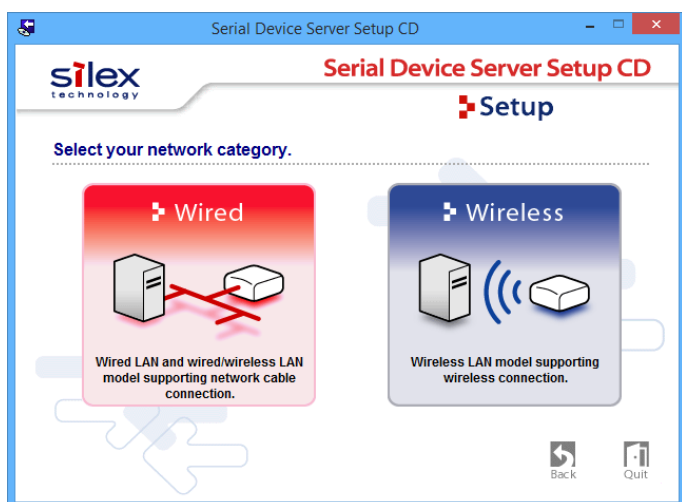



- \* If the User Account Control screen is displayed, click **Continue** or **Yes**.
- \* If the message below is displayed, click **Yes**.

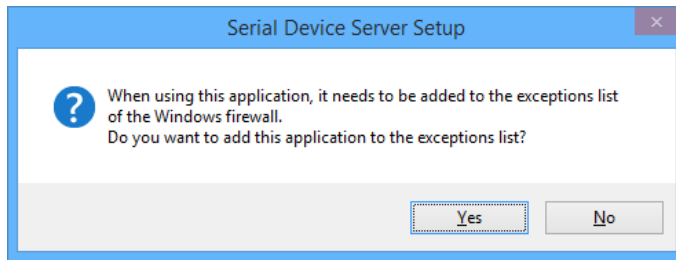

### 4. The Serial Device Server Setup screen is displayed. Click **Next**.



### 5. Read the **SOFTWARE LICENSE AGREEMENT** and click **Yes**.

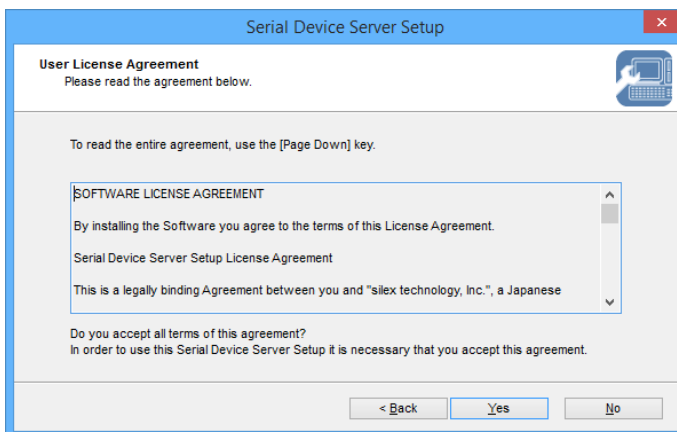

**6.** Select SD-320AN and click **Next**.

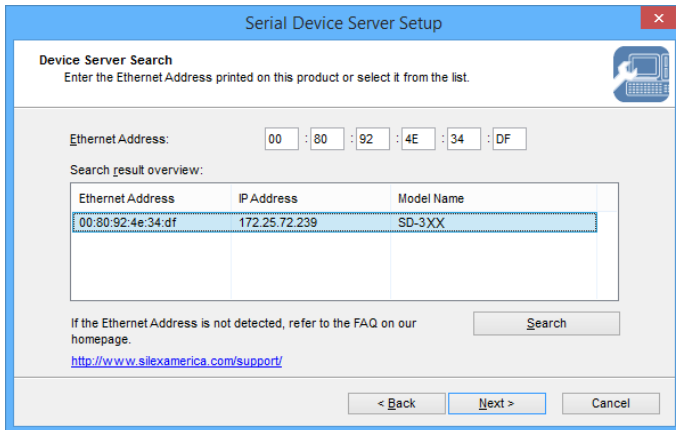

- \* If SD-320AN is using the factory default settings and an IP address other than 0.0.0.0 is displayed in the list, it means the IP address was obtained from a DHCP server.
- \* If SD-320AN is not displayed on the list, click Search. If this does not help, refer to **SD-320AN is not displayed in the search result of Serial Device Server Setup.** in **8-1. Problems During the Setup.**

**7.** Configure the TCP/IP settings appropriate for your environment.



**Note**

- \* If you are not sure how to determine the IP address to set, refer to **How should I determine the way to assign IP address to SD-300?** in **8-1. Problems During the Setup.**

**<< Obtain an IP address automatically from a DHCP server >>**

Select **Get IP Address Automatically** and click **Next**.

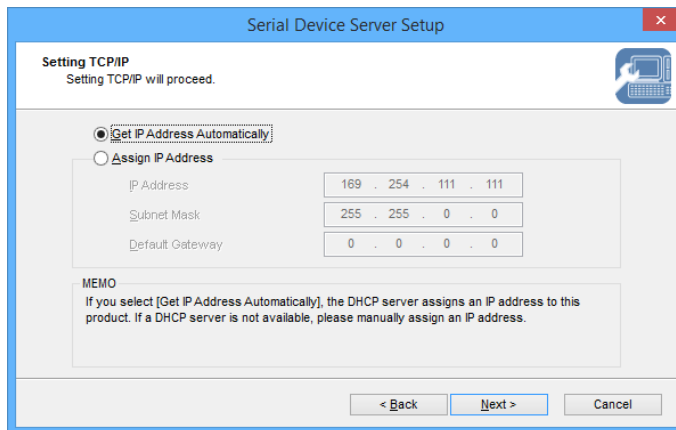

## &lt;&lt; Assign an IP address manually &gt;&gt;

Select **Assign IP Address** and enter an IP address. Click **Next**.

Serial Device Server Setup

Setting TCP/IP  
Setting TCP/IP will proceed.

Get IP Address Automatically  
 **Assign IP Address**

IP Address	169 . 254 . 111 . 111
Subnet Mask	255 . 255 . 0 . 0
Default Gateway	0 . 0 . 0 . 0

MEMO  
If you select [Get IP Address Automatically], the DHCP server assigns an IP address to this product. If a DHCP server is not available, please manually assign an IP address.

< Back   Next >   Cancel

**TIP**

- \* The IP address used in the screen above is a sample address. Please enter an IP address appropriate for your environment.
- \* Enter a **Subnet Mask** and **Default Gateway** if necessary.
- \* If there are no DHCP servers on your network and the IP address of your PC is assigned manually, the screen below will be displayed. Please configure an IP address appropriate for your environment.

Serial Device Server Setup

Setting TCP/IP  
Setting TCP/IP will proceed.

IP Address	0 . 0 . 0 . 0
Subnet Mask	0 . 0 . 0 . 0
Default Gateway	0 . 0 . 0 . 0

< Back   Next >   Cancel

**8.** Configure the wireless settings and click **Next**.



\* The settings used in the screen above are sample values. See the information below for your reference.

**TIP**

Wireless Mode	Fixed to <b>Infrastructure</b> .
SSID	Enter the same SSID as the Access Point.
<b>When encrypting communication using WEP</b>	
Network Authentication	Select <b>Open</b> .
Use WEP	Select <b>ON</b> .
Key Size	Set the same WEP key size as the Access Point (128bit). To enter a WEP key by a string, select <b>128bit (ASCII)</b> . To enter a WEP key by a number, select <b>128bit (hexadecimal)</b> .
WEP Key	Enter the same WEP key as the Access Point.
Key Index	Enter the same key index as the Access Point.
<b>When encrypting communication using WPA</b>	
Network Authentication	Select <b>WPA</b> .
Encryption Mode	Fixed to <b>AUTO</b> .
Pre-Shared Key	Enter the same Pre-Shared key as the Access Point.
<b>When encrypting communication using WPA2</b>	
Network Authentication	Select <b>WPA2</b> .
Encryption Mode	Fixed to <b>AES</b> .
Pre-Shared Key	Enter the same Pre-Shared key as the Access Point.
<b>When using no encryption</b>	
Network Authentication	Select <b>Open</b> .
Use WEP	Select <b>OFF</b> .

## 9. Check the settings and click **Execute**.

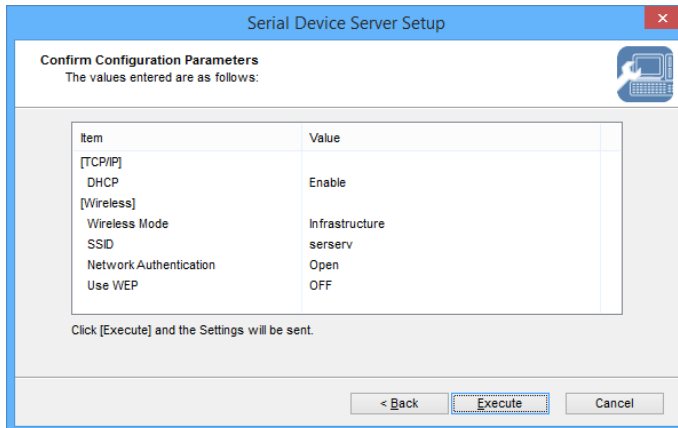

\* The information displayed in this screen will vary depending on the items you have configured.



\* If an error occurs after clicking Execute, please refer to **Communication error occurs when configuring with Serial Device Server Setup.** in **8-1. Problems During the Setup.**

## 10. Select **Yes** and click **Finish**.

Continue to install the SX Virtual Link for Serial Device Server. For details on the installation, refer to **Install Application.**

After the installation is finished, go on to **11.**



\* When **No** is selected, go on to **11.**

11. Remove the power plug from the outlet and the network cable from SD-320AN.

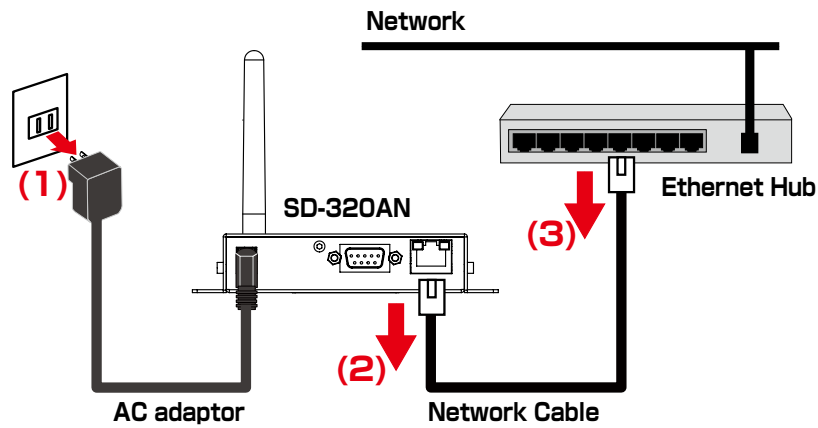

\* If you plan to use SD-320AN in a wired network after completing the configuration, the network cable does not need to be unplugged

12. Connect the serial device that you wish to share over the network to SD-320AN using a serial cable and insert the power plug of SD-320AN into the outlet.

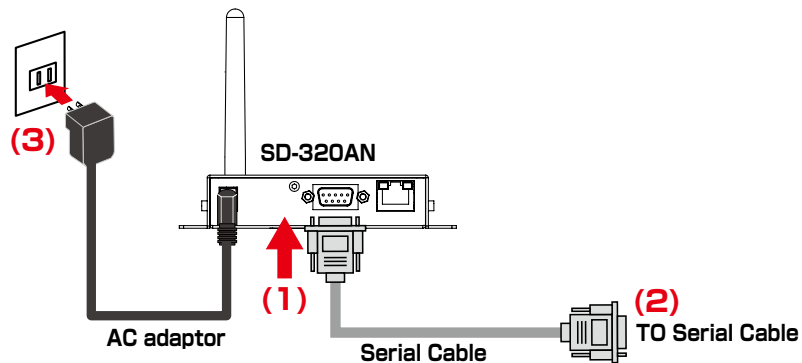

Network configuration is complete.

## 5-5. Configure SD-320AN Using Smart Wireless Setup

This page explains the Smart Wireless Setup which can be used when your wireless router supports the WPS (Wi-Fi Protected Setup).

### Confirm that your wireless router supports WPS

To perform the wireless configuration using WPS, your wireless router must support WPS. Please make sure that a wireless router supporting WPS is set up in your environment.

To see if your wireless router supports WPS or not, refer to the operation manual that came with the router or contact the manufacturer.



**TIP**

- \* Depending on your wireless router, WPS may need to be enabled manually. For details, refer to the operation manual that came with your wireless router.
- \* If a security feature such as MAC Address filtering is enabled on your wireless router, disable it temporarily so that SD-320AN can communicate with your wireless router.

### Configure Network Settings

1. Configure the TCP/IP settings and install the necessary application according to the instructions from **1** to **10** at **5-4. Configure Network Settings**.



**TIP**

- \* The wireless configuration at 8 will not be necessary. Click **Next** then.

2. Access the Web page of SD-320AN using the Web browser.



**Note**

- \* For details on how to access the Web page of SD-320AN using the Web browser, refer to **Access the SD-300/SD-320AN Web Page**.

3. From the left menu on the Web page, click **Wireless LAN**.



4. Click the **Smart Wireless Setup** tab.

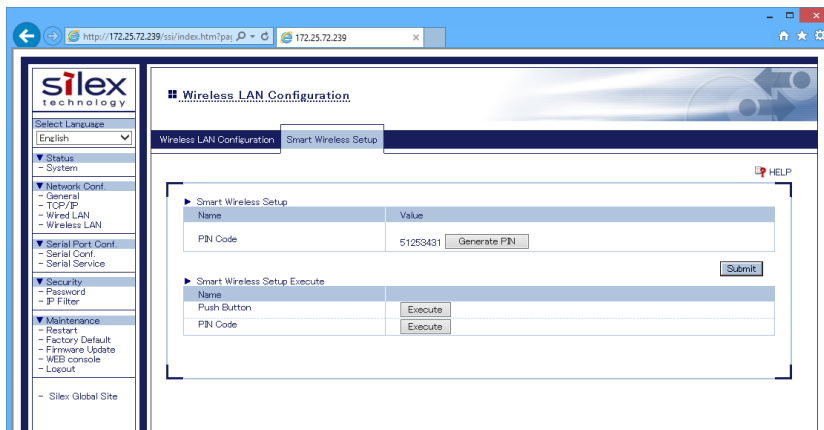

## Push Button Method

1. Press the WPS button on your wireless LAN router.  
Check that your wireless router start to wait for a wireless connection.



### Note

- \* The name, position and shape of the WPS button will differ depending on your wireless router. For details, refer to the operation manual that came with your wireless router.
- \* Please use only one wireless router. If two or more routers are waiting for wireless connections, SD-320AN will not be able to connect properly.

2. In the Web page, click **Execute** at **Push Button**.

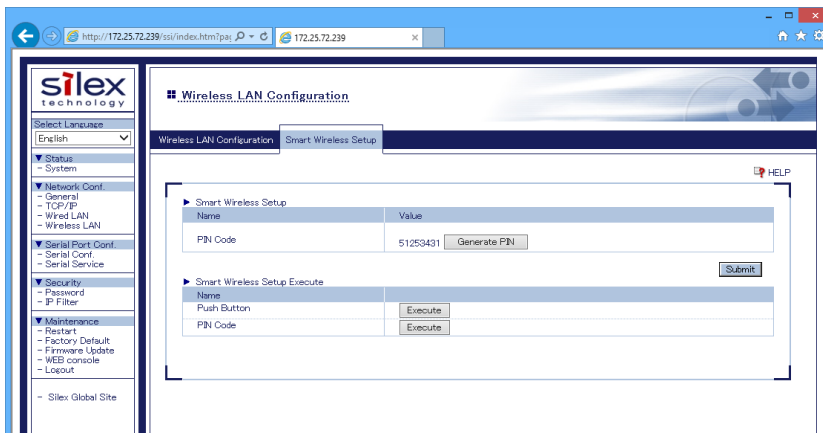

3. The Smart Wireless Setup will begin.

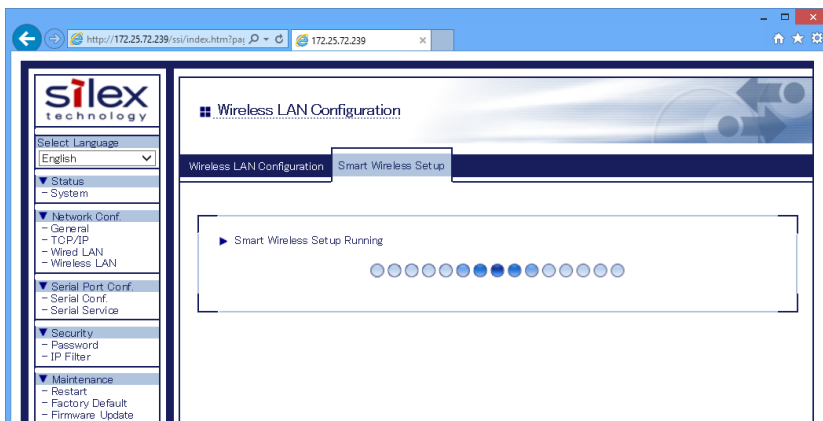

### Note

- \* Depending on your environment, it may take up to 2 mins to finish the wireless configuration.

4. When the configuration is completed, SD-320AN will be configured with the same setting as the wireless router.

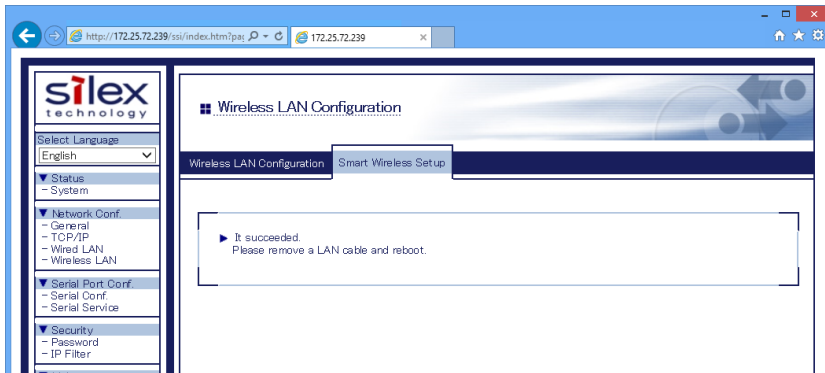

5. Remove the power plug from the outlet and the network cable from SD-320AN.

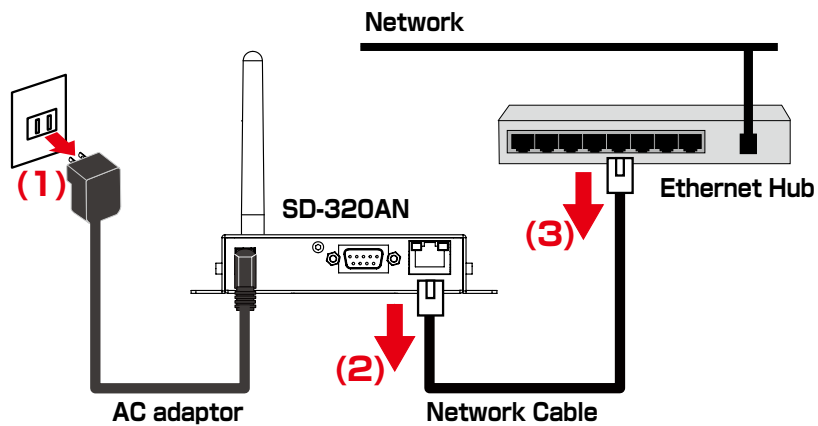

6. Connect the serial device that you wish to share over the network to SD-320AN using a serial cable and insert the power plug of SD-320AN into the outlet.

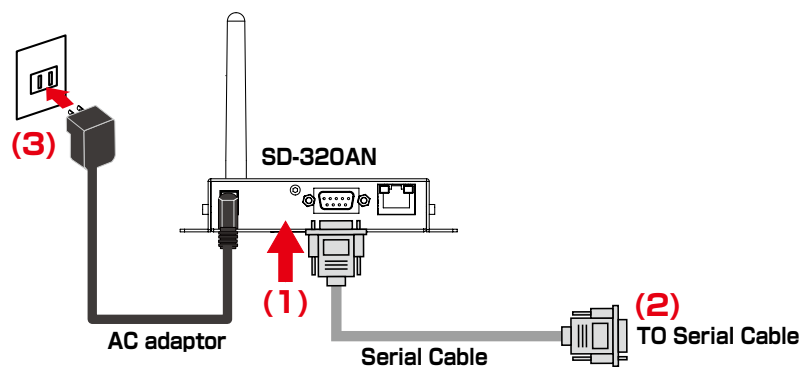

## PIN Code Method

1. Check the PIN code on the Web page.  
Keep displaying the Web page as it will be used again after you enter the PIN code on the Access Point side.

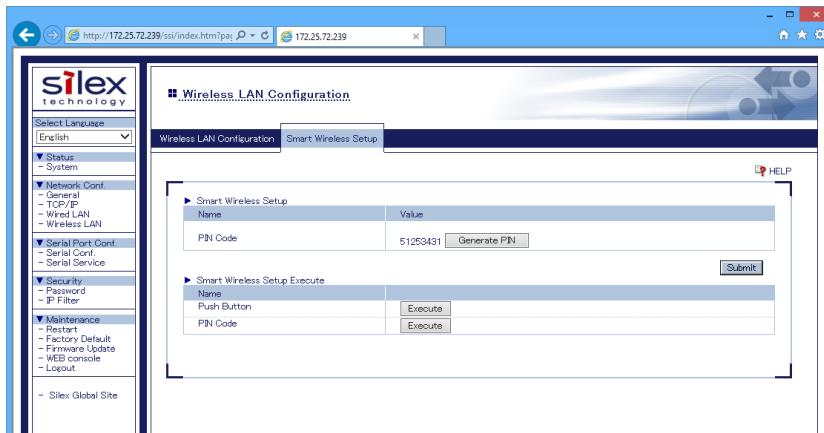

\* To change the PIN code, click Generate PIN. A new PIN code will be issued.

### Note

2. Open the Web page of Access Point using the Web browser (Internet Explorer, Safari, etc). Enter the PIN code and start the WPS on that page.
3. Go back to the Smart Wireless Setup page of SD-320AN after the WPS is started on the Access Point.  
Click **Execute** at **PIN Code**.

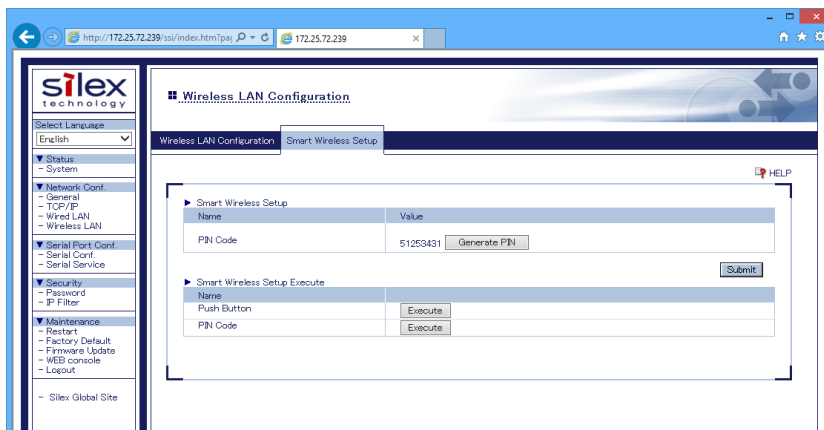

4. The Smart Wireless Setup will begin.

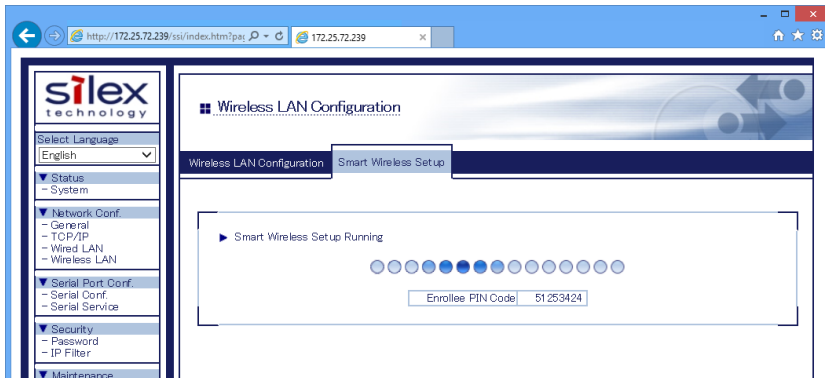

5. When the configuration is completed, SD-320AN will be configured with the same setting as the wireless router.

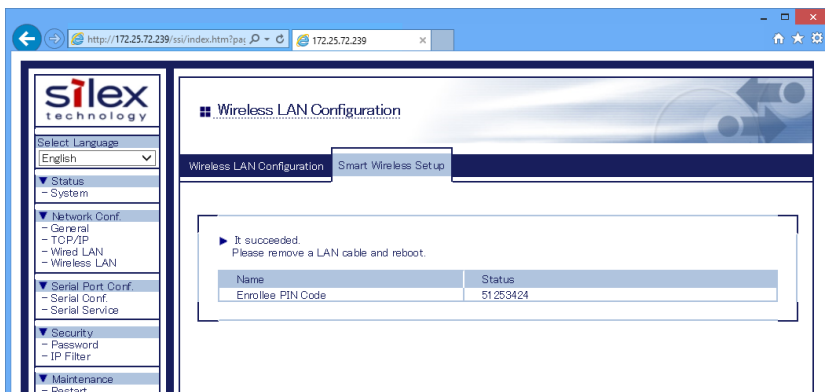

6. Remove the power plug from the outlet and the network cable from SD-320AN.

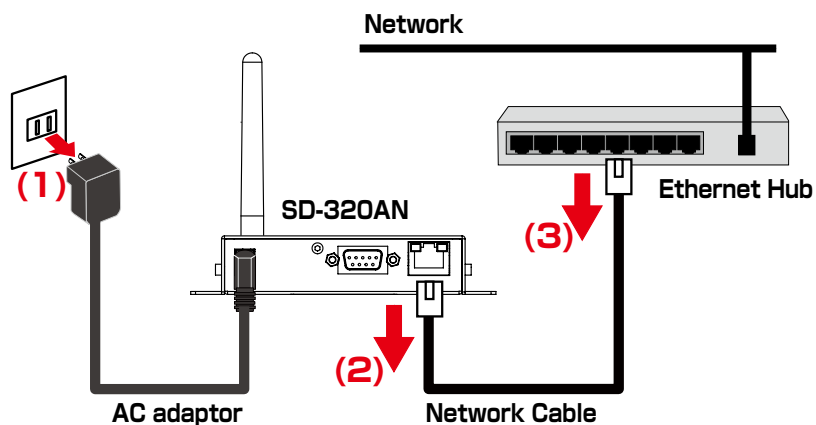

7. Connect the serial device that you wish to share over the network to SD-320AN using a serial cable and insert the power plug of SD-320AN into the outlet.

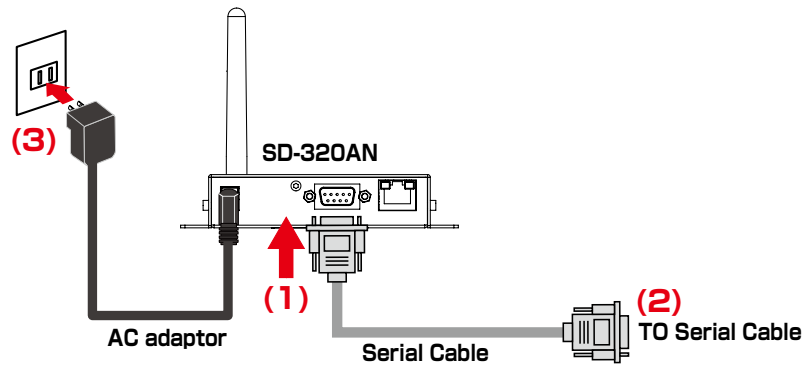



# 6. How to Use

---

## 6-1. Link to Serial Device Using the Serial Device Connection Utility

---

### (Serial Port Emulation Mode)

#### What is Serial Port Emulation Mode?

---

**Serial Port Emulation Mode** is a function to communicate with a serial device on the standard Windows COM port using SX Virtual Link for Serial Device Server. Once this feature is used, users can communicate with the serial device over a network using a serial port communication utility such as a terminal software program.



**Note**

\* If you are using the USB device management utility, "SX Virtual Link", please uninstall it and use "**SX Virtual Link for Serial Device Server**". It can discover, link to and unlink from both USB devices and serial devices. For details on how to install it, see **Install Application**.

## Install Application

This page explains how to install the serial device connection utility, "SX Virtual Link for Serial Device Server".

- \* If SX Virtual Link for Serial Device Server is not installed yet, install it according to the instructions below.
- \* If you have completed the configuration and continue to install the application, start from 3 in this section.



**TIP**

- \* Administrator privilege is required for installation.



**Note**

- \* If you are using the USB device management utility, "SX Virtual Link", you can use "SX Virtual Link for Serial Device Server" instead of "SX Virtual Link" to discover, link to and unlink from both USB devices and serial devices.

1. Extract the compressed file of **SX Virtual Link for Serial Device Server** that you have downloaded.

Double-click **Cosetup.exe** in the extracted folder to start the **SX Virtual Link for Serial Device Server** installer.



**TIP**

- \* If the User Account Control screen is displayed, click Yes or Continue.

2. Select **English** and click **Next**.

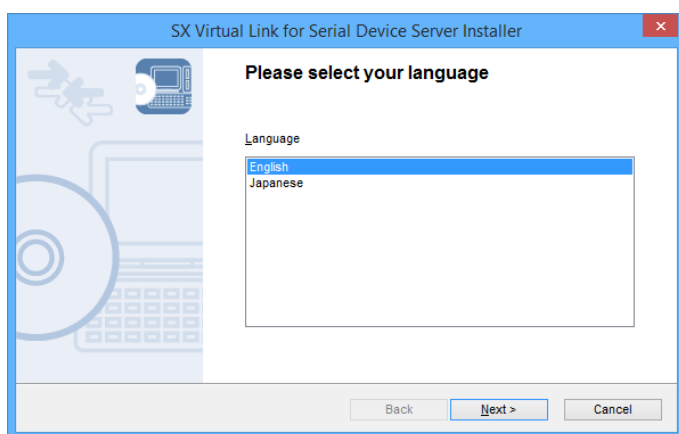

3. SX Virtual Link for Serial Device Server Install wizard is displayed. Click **Next**.



4. Read the **SOFTWARE LICENSE AGREEMENT** and click **Yes**.

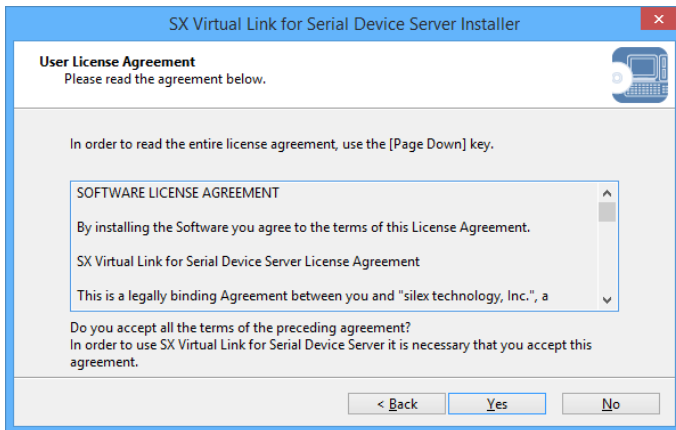

5. Select a folder to install SX Virtual Link for Serial Device Server into and click **Next**.

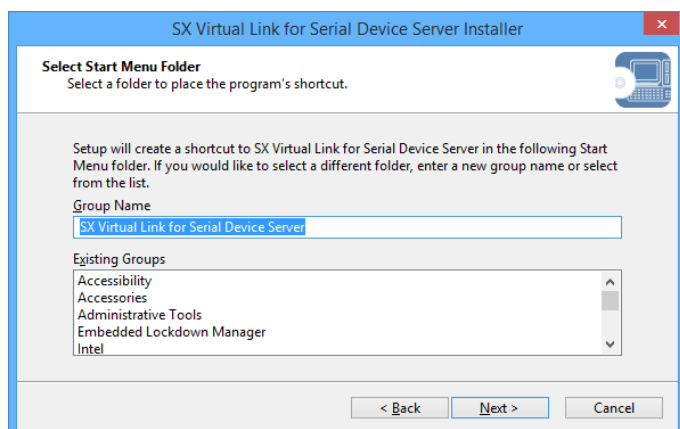
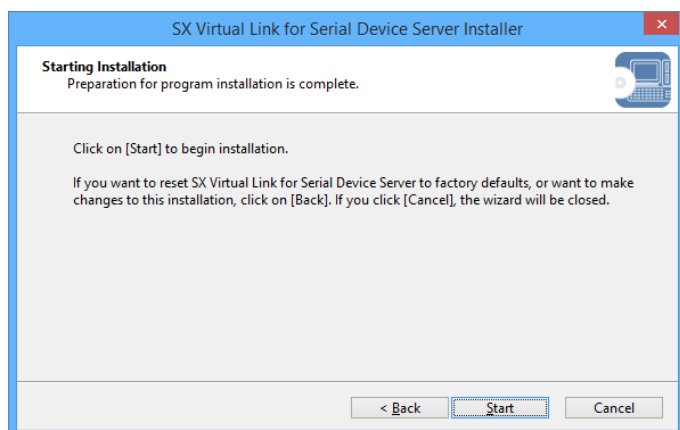
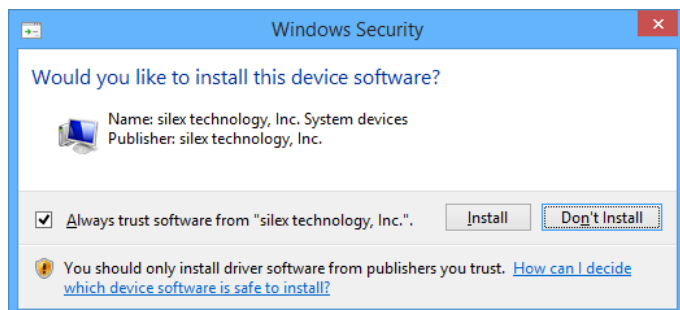

**6.** Enter a Group Name to be displayed in the Start Menu. Click **Next**.**7.** Click Start to begin the installation.**8.** A confirmation message for software installation is displayed. Click **Install**.

Again, click **Install**.

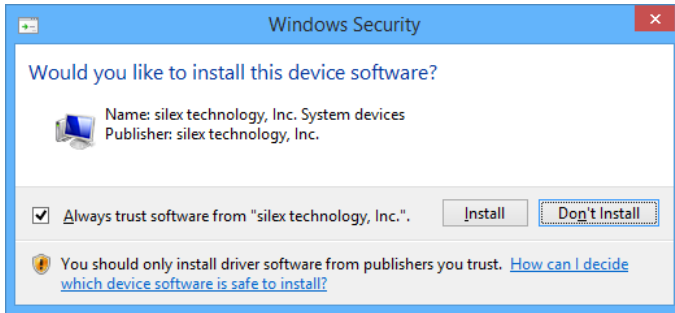

\* If the message below is displayed, click Yes.



9. Select an appropriate action that you wish to take when a new serial device is discovered and click Next.

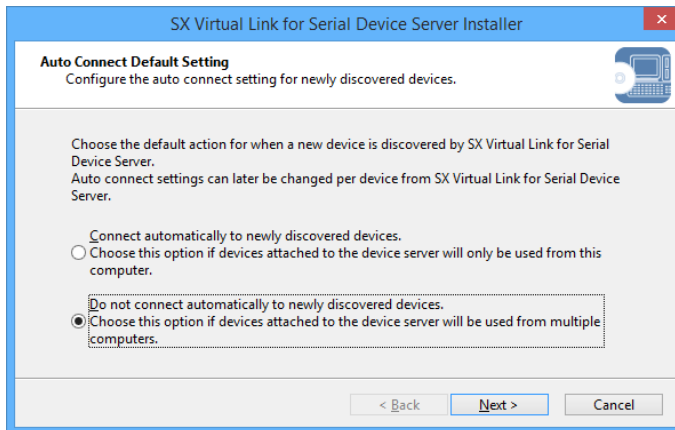

\* This screen does not appear if SX Virtual Link for Serial Device Server has already been installed.

10. SX Virtual Link for Serial Device Server has been installed. Click **Finish**.

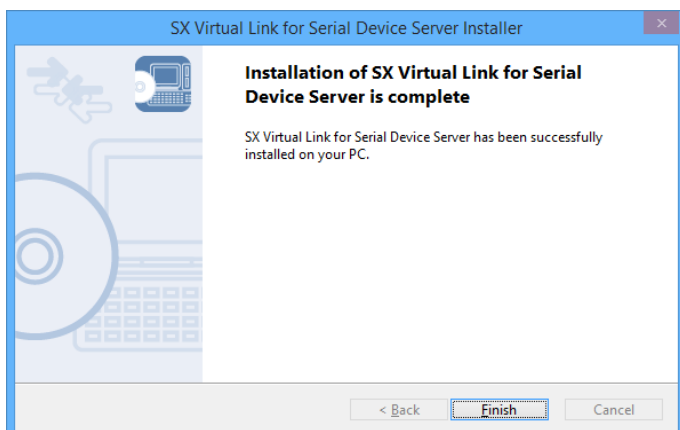

\* If using a firewall function of commercial security software, please add SX Virtual Link for Serial Device Server to the exception list in your security software. Refer to the FAQ on our website ( <http://www.silexamerica.com/> ) for details on adding an application to the exception list.

Application installation is complete. SX Virtual Link for Serial Device Server will run.

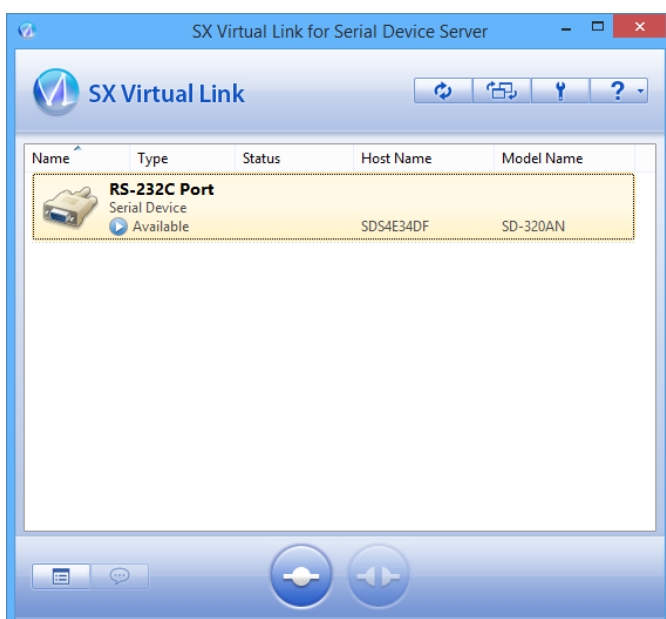

## Start SX Virtual Link for Serial Device Server

How to start SX Virtual Link for Serial Device Server is as follows:

1. Click the icon  in the task tray.



### Note

\* If SX Virtual Link for Serial Device Server is not running, click **Start - All Programs - SX Virtual Link for Serial Device Server - SX Virtual Link for Serial Device Server**.

2. The SX Virtual Link for Serial Device Server's main window appears and the serial devices running on the network are displayed in the device list.

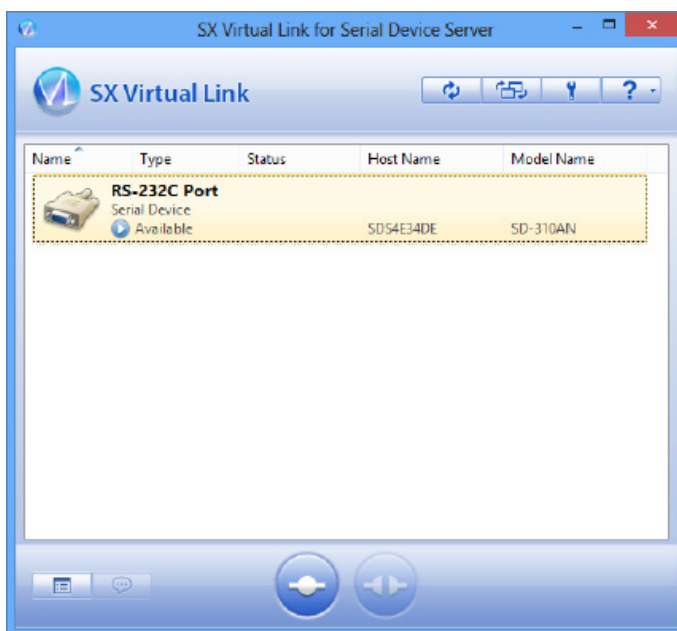

## Link to a serial device

How to link to serial device is as follows:

1. Select the serial device in SX Virtual Link for Serial Device Server's main window and connect to it.

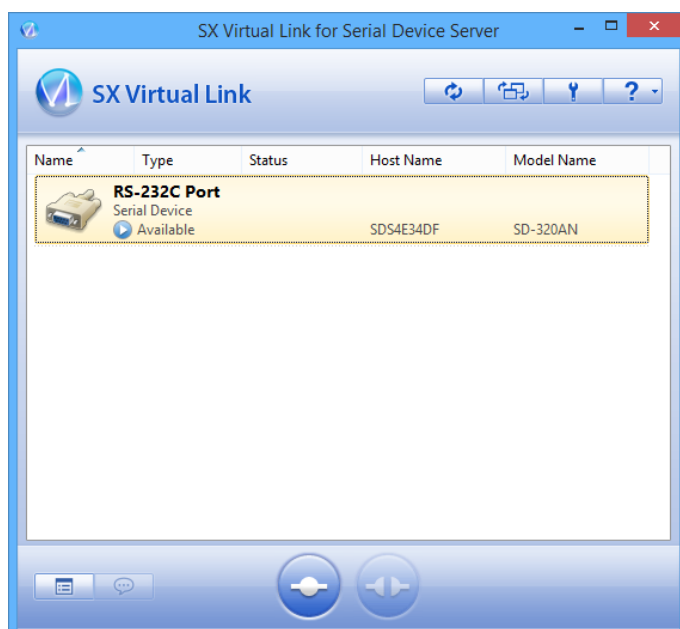

### How to Link:

Double-click	Double-click the serial device in SX Virtual Link for Serial Device Server's main window.
Use a button	Select the serial device and click the Connect button  in SX Virtual Link for Serial Device Server's main window.
Right-click	Right-click on the serial device in SX Virtual Link for Serial Device Server's main window and click <b>Connect</b> in the menu displayed.
Use a keyboard	Select the serial device using the up/down arrow keys and press <b>Alt + C</b> on your keyboard.



## Note

\* To specify the COM port manually, please complete the following steps before you link to the serial device.

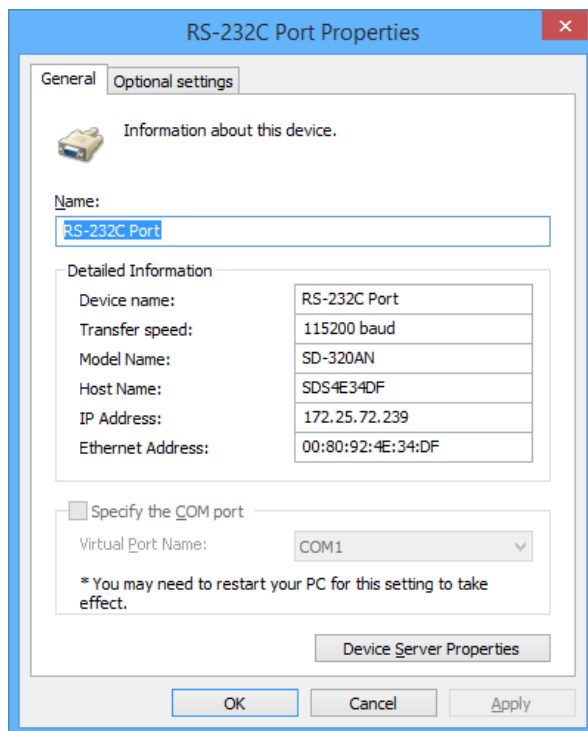

1. Select the serial device that you wish to link and click the Properties button  .
2. In the General tab, check Specify the **COM** port check box and select the COM port that you wish to use from **Virtual Port Name**.

Do not select one that is already used on your system.



3. Click **OK**.

The COM port has been specified.

\* When the Connect button  is clicked, the message below may be displayed. Check the message and click **OK**. Finish the COM port currently used in your system and click the Connect button  again.

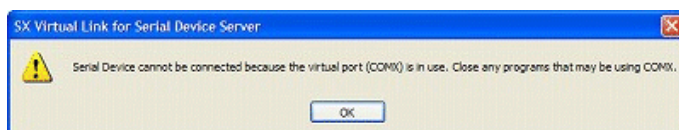

2. Once you successfully link to the serial device, the status icon is changed in SX Virtual Link for Serial Device Server's main window.

The COM port that you have selected is displayed in the status column.



### Note

\* If Found New Hardware Wizard is displayed, install software for the device according to the followings:

1. Select **No, not this time** and click **Next**.



2. Select **Install the software automatically (Recommended)** and click **Next**.

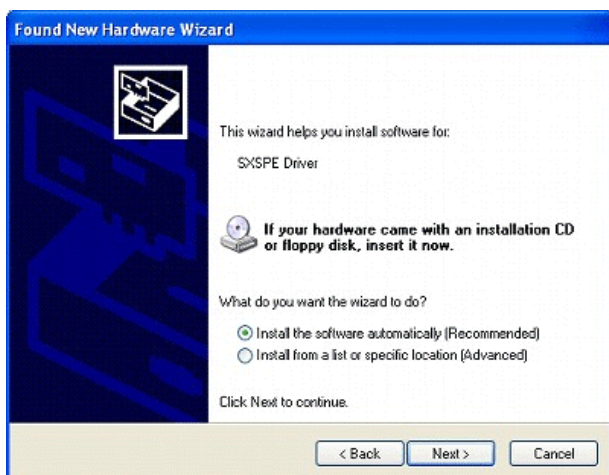

3. Click Continue **Anyway**.



4. Click **Finish**.



The software has been installed. You can link to the serial device using it.

## Start a serial communication software

Start a serial communication software such as a terminal software.

On the serial communication software, select the COM port that is displayed in the status column of SX Virtual Link for Serial Device Server's main window. Also, configure the serial port settings such as a baud rate, stop bit, etc.

Once the communication settings are complete, you can communicate with the serial device connected to SD-300/SD-320AN.

## Unlink from a serial device

How to unlink from serial device is as follows:

Select the serial device in SX Virtual Link for Serial Device Server's main window and disconnect from it.

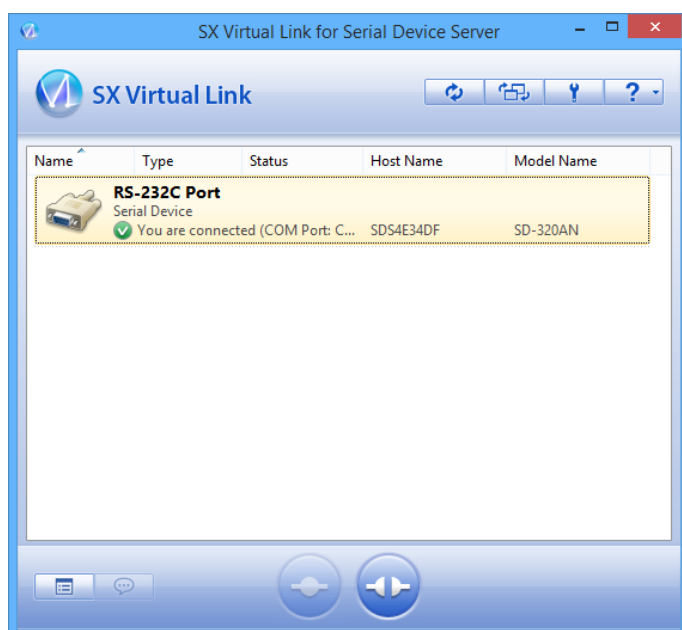

### How to Unlink:

Double-click	Double-click the serial device in SX Virtual Link for Serial Device Server's main window.
Use a button	Select the serial device and click the Disconnect button  in SX Virtual Link for Serial Device Server's main window.
Right-click	Right-click on the serial device in SX Virtual Link for Serial Device Server's main window and click <b>Disconnect</b> in the menu displayed.
Use a keyboard	Select the serial device using the up/down arrow keys and press <b>Alt + D</b> on your keyboard.

## 6-2. Ecable Mode

### (Link to the Registered Device)

#### What is Ecable Mode?

Ecable Mode is a feature that allows serial devices with no network interface to communicate with each other using two SD-300/SD-320AN's.

Connect one SD-300/SD-320AN to the transmitter end and one to the receiver end, and register the IP address of the receiver end as a destination address of the transmitter end. When they are powered on, both SD-300/SD-320AN's will start communicating with each other, establishing bidirectional communication between the serial devices.

#### Before You Begin

Change the settings to use SD-300/SD-320AN in Ecable Mode.

1. Access the Web page of the SD-300/SD-320AN that you wish to use as the transmitter end.



\* For details on how to access the Web page, refer to **Access the SD-300/SD-320AN Web Page**.

#### Note

2. In the left pane of the Web page, click **General**.



### 3. Select **OFF** for **SX Virtual Link compatibility**.

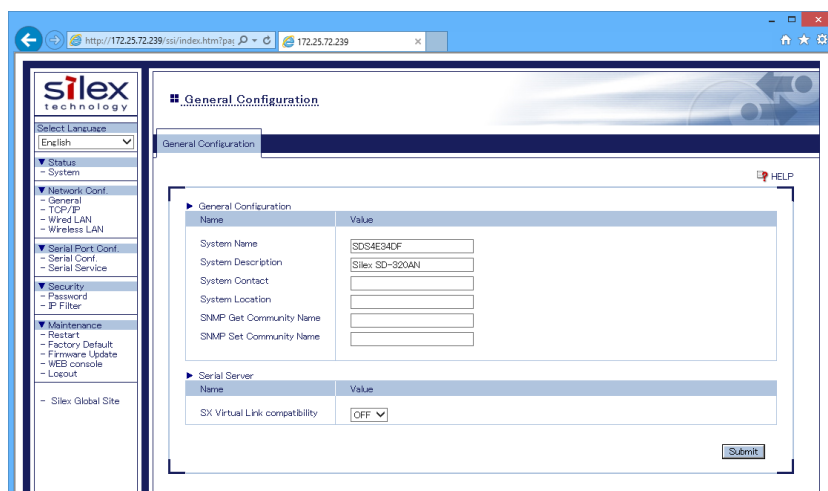

When completed, click the **Submit** button.

### 4. In the left pane of the Web page, click **Serial Conf.**



### 5. In the page displayed, configure the following settings at **General Configuration** as appropriate for your serial device.

- \* Baud Rate
- \* Bits per character
- \* Stop Bits
- \* Parity
- \* Flow Control

Select Enabled for **Ecable Mode**.

For **Destination IP Address**, enter the IP address of the receiver end (another SD-300/SD-320AN).

And for **Destination Port**, enter the port number that you wish to use.

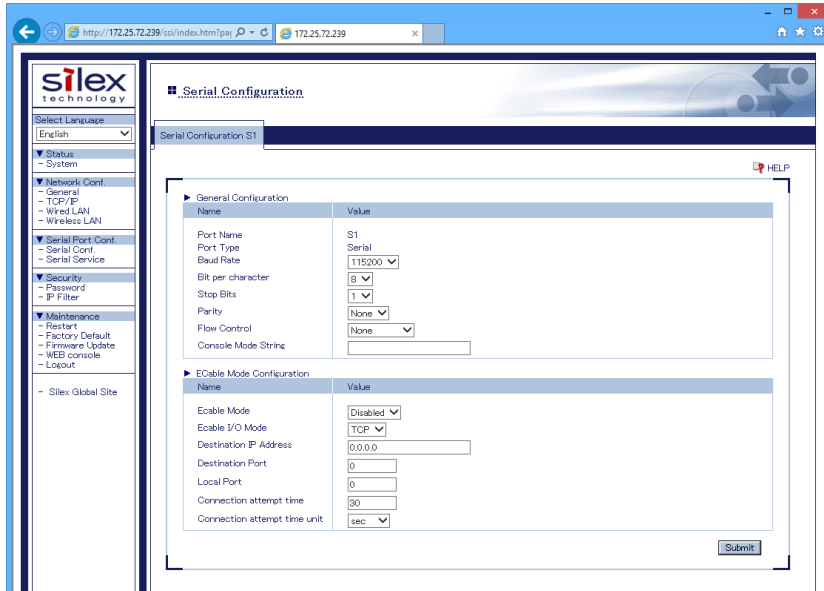

When completed, click the **Submit** button.

6. Also, access the Web page of the receiver end and click **General**.



## 7. Select **OFF** for **SX Virtual Link compatibility**.

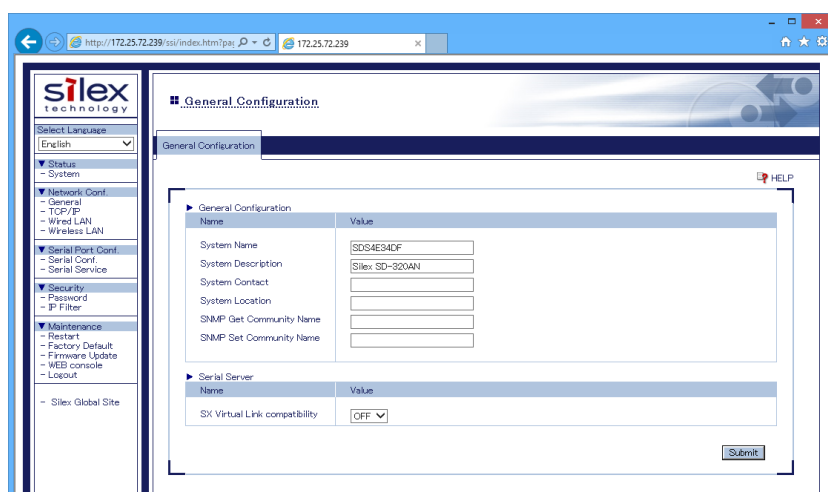

The screenshot shows the Silex Technology web interface. The left sidebar contains a navigation menu with categories like Status, Network Conf., Serial Port Conf., Security, and Maintenance. The main content area is titled 'General Configuration' and contains two sections: 'General Configuration' and 'Serial Server'. The 'General Configuration' section has a table with the following data:

Name	Value
System Name	SDS4E34DF
System Description	Silex SD-320AN
System Contact	
System Location	
SNMP Get Community Name	
SNMP Set Community Name	

The 'Serial Server' section has a table with the following data:

Name	Value
SX Virtual Link compatibility	OFF

A 'Submit' button is located at the bottom right of the configuration area.

When completed, click the **Submit** button.

## 8. In the left pane of the Web page, click **Serial Conf.** and configure the settings at **General Configuration**.

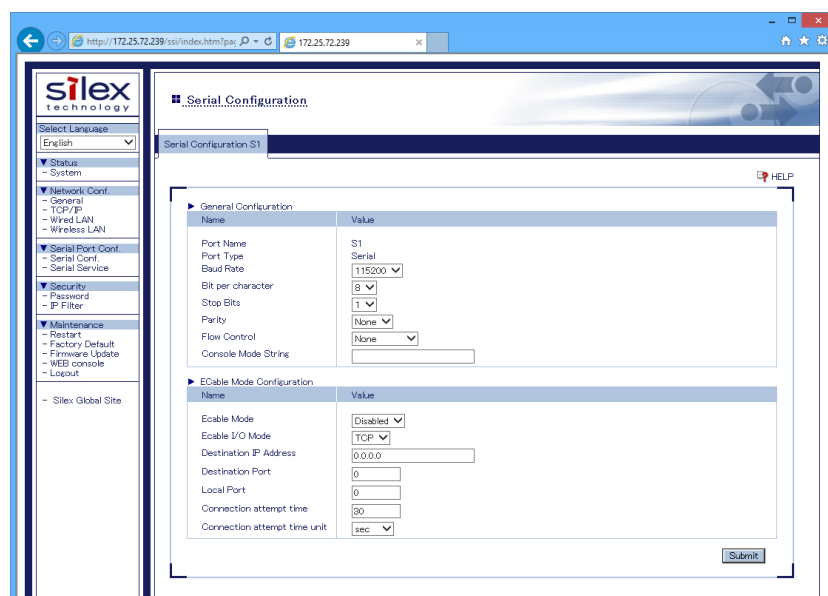

The screenshot shows the Silex Technology web interface. The left sidebar contains a navigation menu with categories like Status, Network Conf., Serial Port Conf., Security, and Maintenance. The main content area is titled 'Serial Configuration' and contains two sections: 'General Configuration' and 'ECable Mode Configuration'. The 'General Configuration' section has a table with the following data:

Name	Value
Port Name	S1
Port Type	Serial
Baud Rate	115200
Bit per character	8
Stop Bits	1
Parity	None
Flow Control	None
Console Mode String	

The 'ECable Mode Configuration' section has a table with the following data:

Name	Value
Ecable Mode	Disabled
Ecable I/O Mode	TCP
Destination IP Address	0.0.0.0
Destination Port	0
Local Port	0
Connection attempt time	30
Connection attempt time unit	sec

A 'Submit' button is located at the bottom right of the configuration area.

When completed, click the **Submit** button.

9. In the left pane of the Web page, click **Serial Service**.



10. For TCP Port, enter the same value for both receiver end and transmitter end.

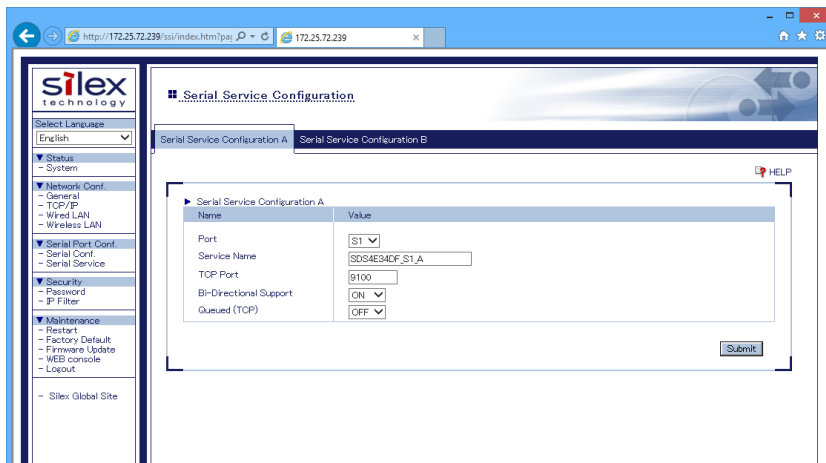

When completed, click the **Submit** button.

The configuration has been completed.

## Link to Serial Device

Power on both serial devices and then both SD-300/SD-320AN's. After they are powered on, bidirectional communication will be active between the serial devices.

## 6-3. Raw TCP Connection Mode

### (Link to Serial Device Using TCP Raw Port)

#### What is Raw TCP Connection Mode?

Raw TCP Connection Mode is a feature used to send or receive serial port data transparently over TCP/IP.

Using this feature, you can directly communicate with a serial device using an application program that runs on the TCP Socket API.

#### Before You Begin

Change the settings to use SD-300/SD-320AN in Raw TCP Connection Mode.

1. Access the Web page of SD-300/SD-320AN.



\* For details on how to access the Web page, refer to **Access the SD-300/SD-320AN Web Page**.

#### Note

2. In the left pane of the Web page, click **General**.



### 3. Select OFF for SX Virtual Link compatibility.

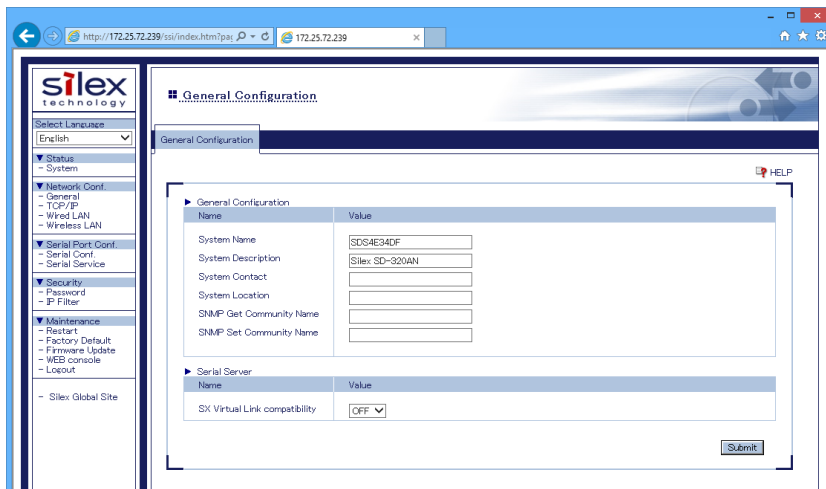

When completed, click the **Submit** button.

### 4. In the left pane of the Web page, click **Serial Conf.**



5. In the page displayed, configure the following settings at **General Configuration** as appropriate for your serial device.

- \* Baud Rate
- \* Bits per character
- \* Stop Bits
- \* Parity
- \* Flow Control

General Configuration	
Name	Value
Port Name	S1
Port Type	Serial
Baud Rate	115200
Bit per character	8
Stop Bits	1
Parity	None
Flow Control	None
Console Mode String	

ECable Mode Configuration	
Name	Value
Ecable Mode	Disabled
Ecable I/O Mode	TCP
Destination IP Address	0.0.0.0
Destination Port	0
Local Port	0
Connection attempt time	30
Connection attempt time unit	sec

When completed, click the **Submit** button.

6. In the left pane of the Web page, click **Serial Service**.



**7.** For **TCP Port**, enter the TCP port number that you wish to use for your application.

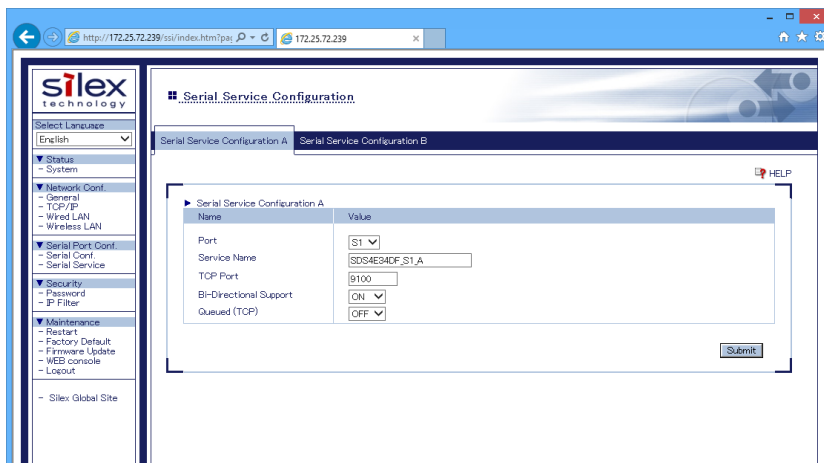

When completed, click the **Submit** button.

The configuration has been completed.

## Link to Serial Device

Power on the serial devices and then SD-300/SD-320AN.

Start an application that runs on the TCP Socket API from your PC and bidirectional communication with the serial device will be active when a link is established.

## 6-4. Use Access Point Feature

### Before You Begin

How to turn on the Access Point mode on SD-320AN is explained as follows.

#### 1. Access the Web page of SD-320AN.



\* For details on how to access the Web page, refer to **Access the SD-300/SD-320AN Web Page**.

#### **Note**

#### 2. In the left pane of the Web page, click **Wireless LAN**.



**3.** Select **AccessPoint** at **Wireless Mode** and configure the following settings at **Wireless LAN Basic Configuration**.

- \* SSID
- \* Channel
- \* Network Authentication

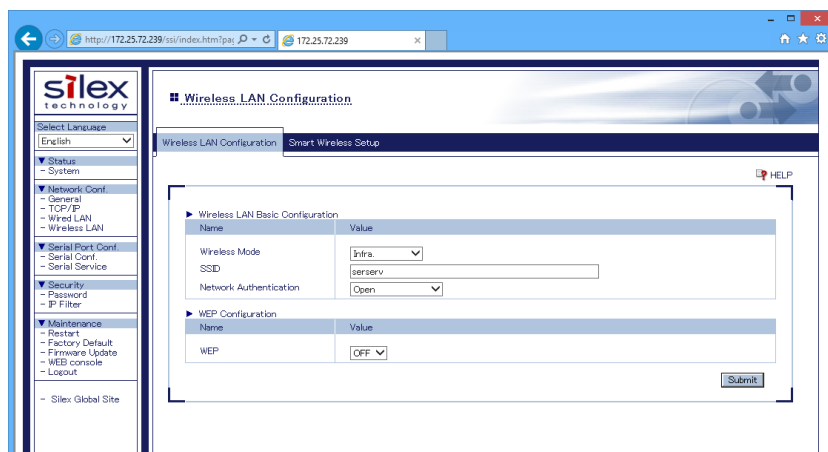

When it is finished, click **Submit**.

**4.** To take effect of the changes, restart SD-320AN by clicking **Restart** from the left pane of the Web page.



**Note**

- \* If you are to continue configuration on the other pages, you do not have to restart SD-320AN. Restart it when all configuration is done.

The configuration has been completed.

## Link to Wireless Client Devices

The following explains how to make a link from the wireless client device when SD-320AN is operating in Access Point mode.

Below configuration methods are available:

- \* Configure the Wireless Settings on a Client Device
- \* Make a Link Using the Web Page of SD-320AN
- \* Make a Link Using the PIN Code



**TIP**

\* To make a link using the Web page or PIN code, your wireless client device needs to support WPS.

### <<Configure the Wireless Settings on a Client Device>>

Configure the client device with the same wireless settings as SD-320AN.

For details on how to configure the settings on the client device, refer to the operating manual that came with the client device.

After the configuration is completed, the client device can be used wirelessly via SD-320AN.

### <<Make a Link Using the Web Page of SD-320AN>>



**TIP**

\* Move the wireless client device closer to SD-320AN so that both devices can communicate.

**1.** Check that the client device supports WPS and is powered on.

**2.** Access the Web page of SD-320AN.



**Note**

\* For details on how to access the Web page, refer to **Access the SD-300/SD-320AN Web Page**.

3. In the left pane of the Web page, click **Wireless LAN**.



4. Click the **Smart Wireless Setup** tab.

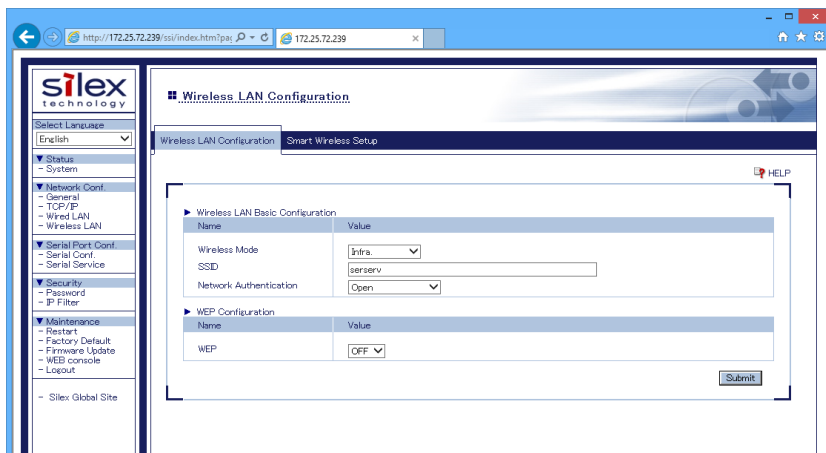

5. Click **Execute** at **Push Button**.

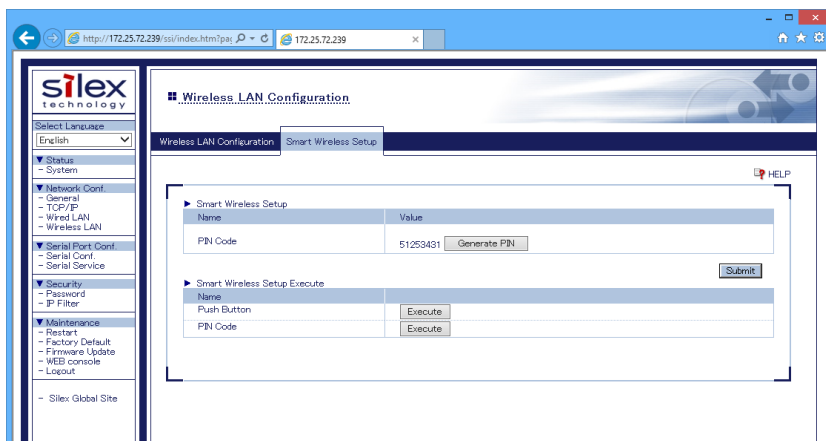

## 6. Press the wireless configuration switch on the client device.



### Note

- \* The name, position and shape of the wireless configuration switch (WPS button) will differ depending on your wireless device. For details, refer to the operation manual that came with your wireless device.
- \* Please use only one wireless device. Even if two or more devices are waiting for wireless connections, SD-320AN can connect only one device which replied first.

## 7. The Smart Wireless Setup will begin.

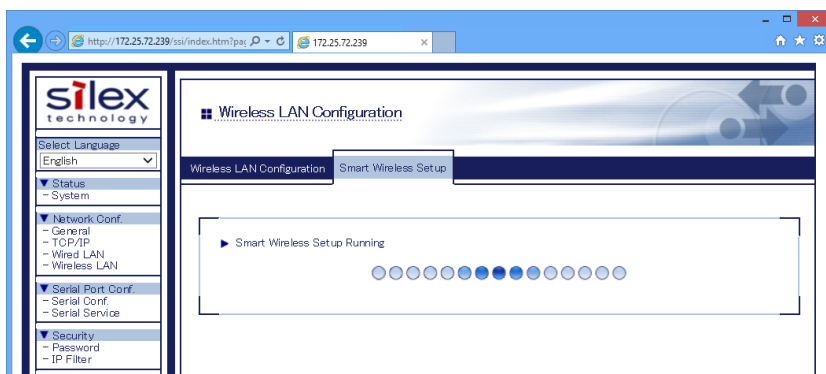

8. When the configuration is completed, the same setting as SD-320AN is configured to the wireless client device.  
Check that the client device communicates with SD-320AN.

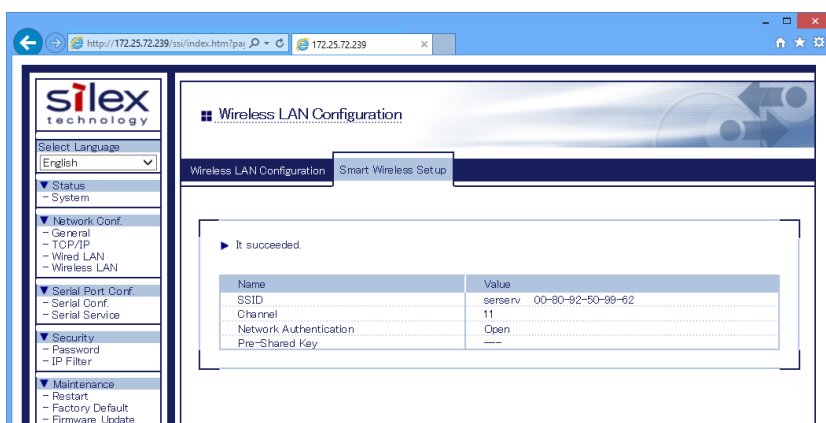

## <<Make a Link Using the PIN Code>>



\* Move the wireless client device closer to SD-320AN so that both devices can communicate.

1. Check that the client device supports WPS and is powered on.
2. Access the Web page of SD-320AN.



\* For details on how to access the Web page, refer to **Access the SD-300/SD-320AN Web Page**.

### Note

3. In the left pane of the Web page, click **Wireless LAN**.



4. Click the **Smart Wireless Setup** tab.

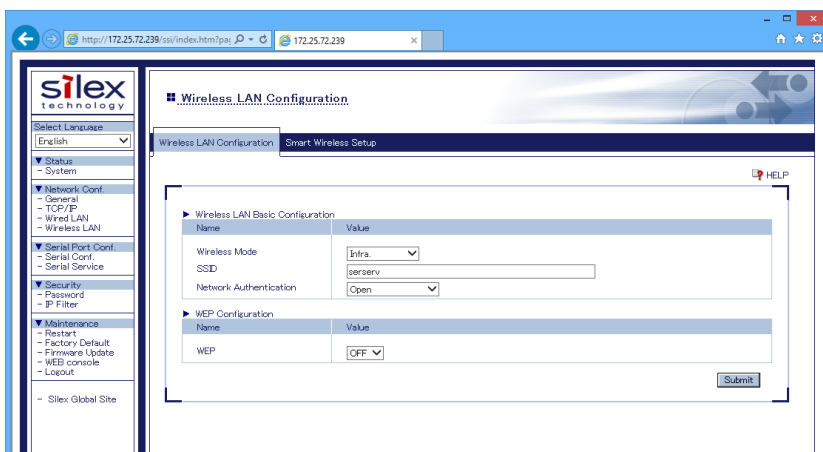

5. Enter the PIN code of the wireless client device at **PIN Code** and click **Execute**.

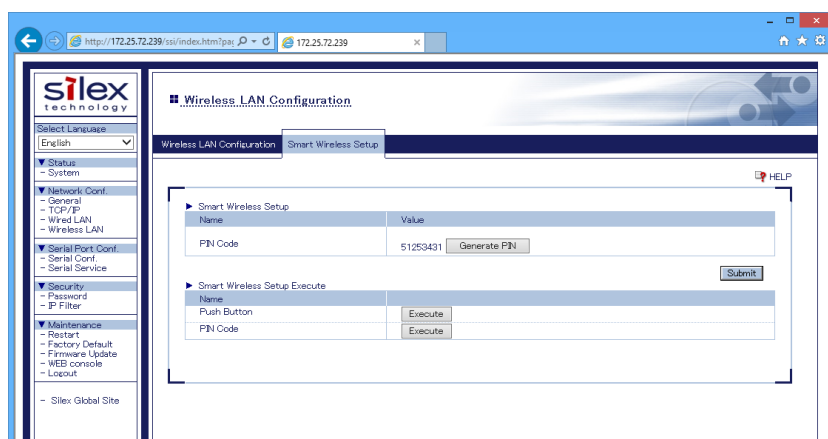

6. The Smart Wireless Setup will begin.

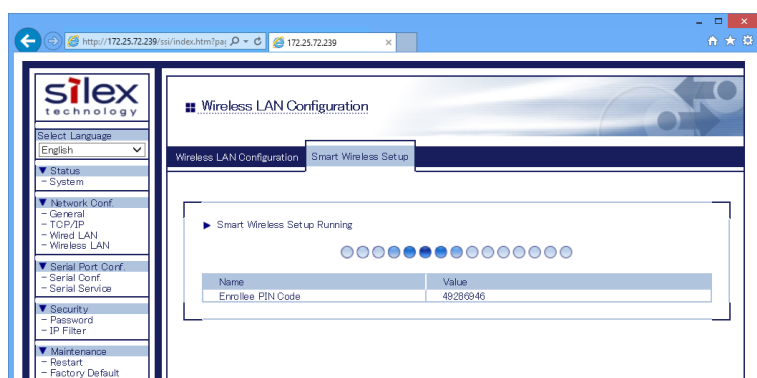

7. When the configuration is completed, the same setting as SD-320AN is configured to the wireless client device.  
Check that the client device communicates with SD-320AN.

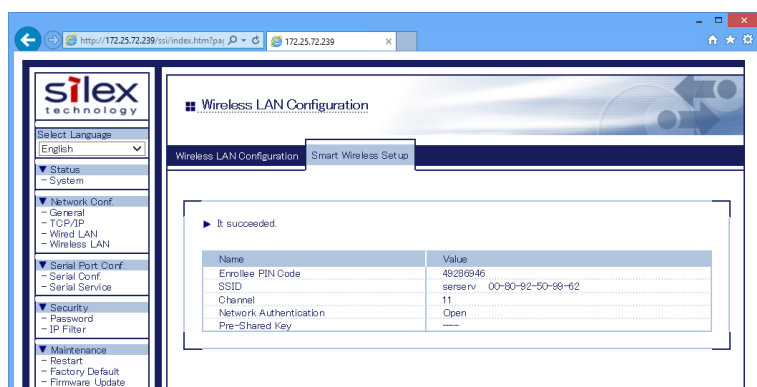



# 7. Other Functions

---

## 7-1. Configure Using the SD-300/SD-320AN Web Page

Since SD-300/SD-320AN has the HTTP protocol, advanced settings can be configured or changed via a Web browser. Useful functions such as a remote restart or factory default configuration for SD-300/SD-320AN are available.



- \* To use a Web browser, the TCP/IP settings need to be enabled, and an IP address needs to be configured.
- \* We recommend the following Web browsers:

Microsoft Internet Explorer 9 or higher
---

Microsoft Edge 20 or higher
-----------------------------

Mozilla Firefox 3.0.0 or higher
---------------------------------

Google Chrome Version 51 or higher
------------------------------------

### Access the SD-300/SD-320AN Web Page

<<Use SX Virtual Link for Serial Device Server to display the Web page>>

1. In the SX Virtual Link for Serial Device Server's main window, select the serial device connected to SD-300/SD-320AN and then click **Properties** button  .

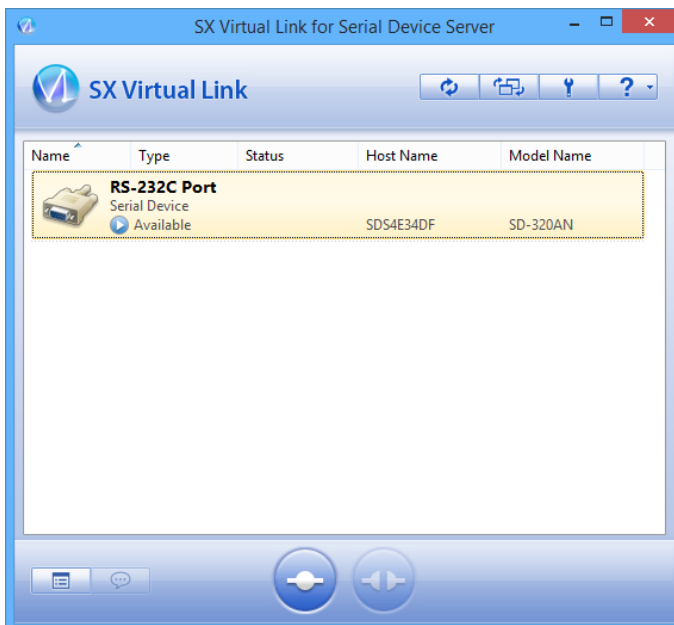

2. Properties dialog is displayed. In the **General** tab, click **Device Server Properties**.

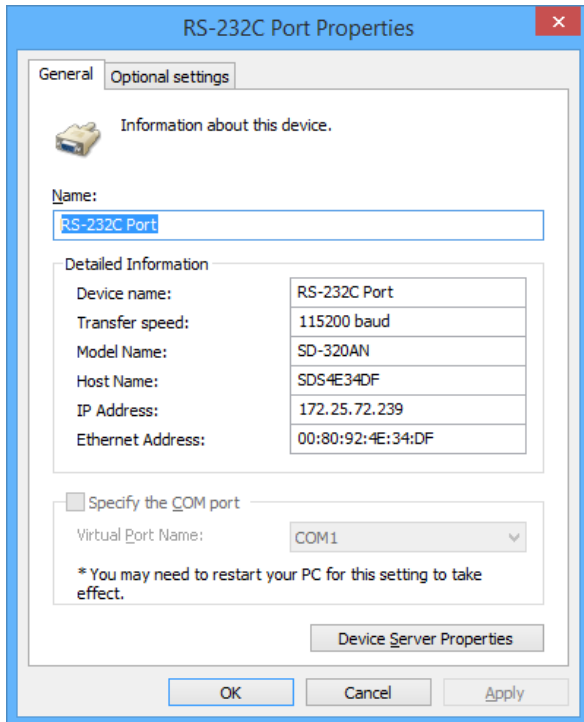

3. The Web browser will run and the Web page will be displayed.

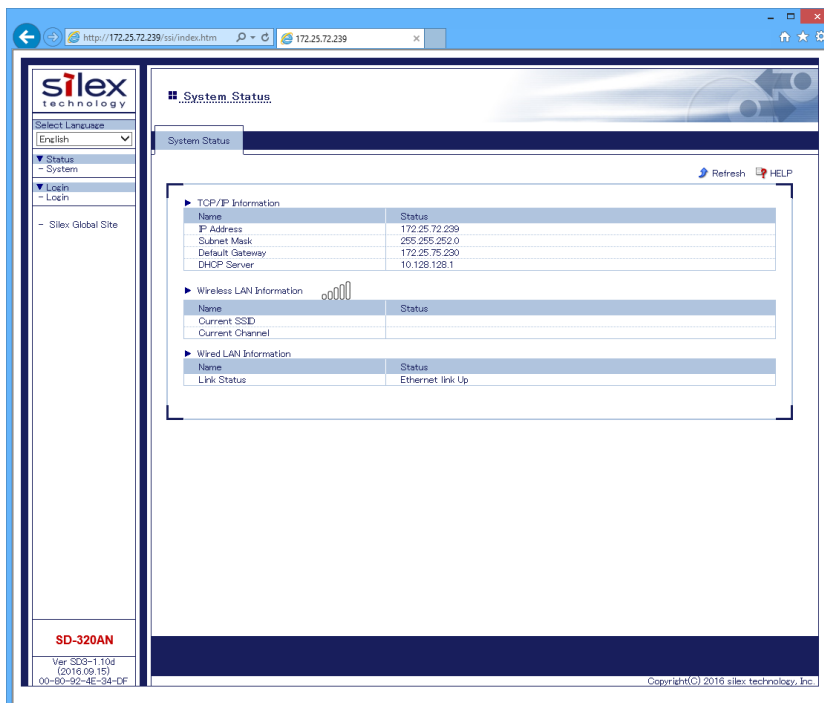

## <<Use a Web browser to display the Web page>>

1. Enter the IP address that is configured on SD-300/SD-320AN in the address bar of the Web browser. Press the ENTER key.

**Example)** Enter 172.25.72.239 and press the ENTER key.

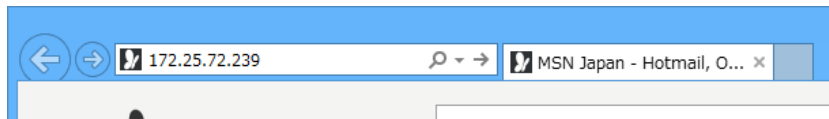

2. The Web browser will run and the Web page will be displayed.

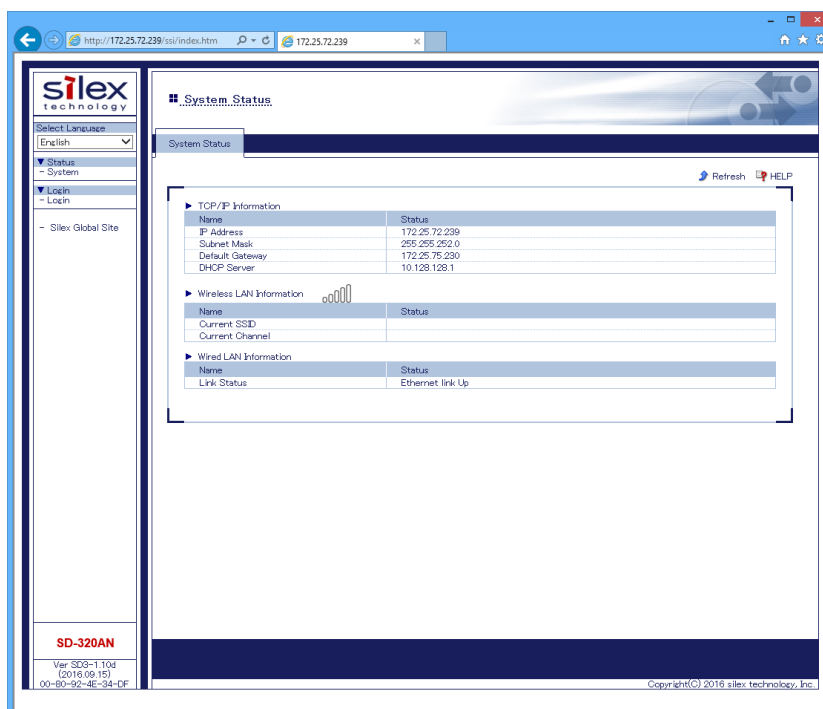

## Log in to the SD-300/SD-320AN Web Page

Follow the instructions below to log in to the Web page.

1. In the left pane of the Web page, click **Login**.



2. In the login page, enter the password and click **Login**.

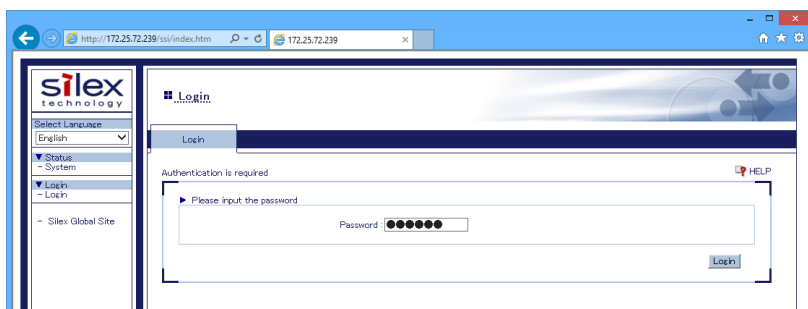

### Note

\* By defaults, the login password is set to access.

## Log out the SD-300/SD-320AN Web Page

Follow the instructions below to log out the Web page.

1. In the left pane of the Web page, click **Logout**.

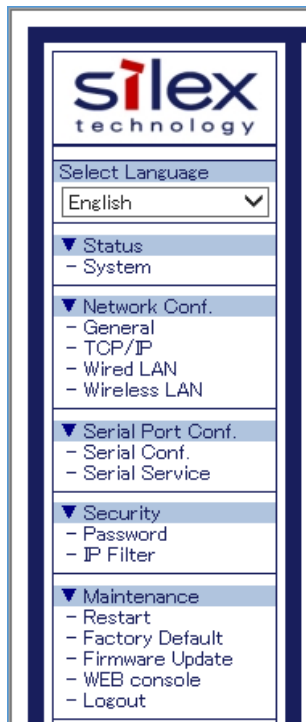

2. Click **Yes** to the confirmation message.

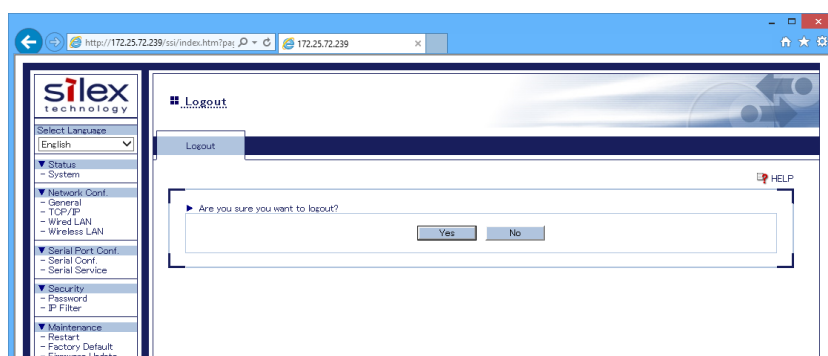

## Configure Advanced Network Settings

### <<General Configuration>>

In the left pane of the Web page, click **General**.  
Enter or select the setting and click **Submit**.

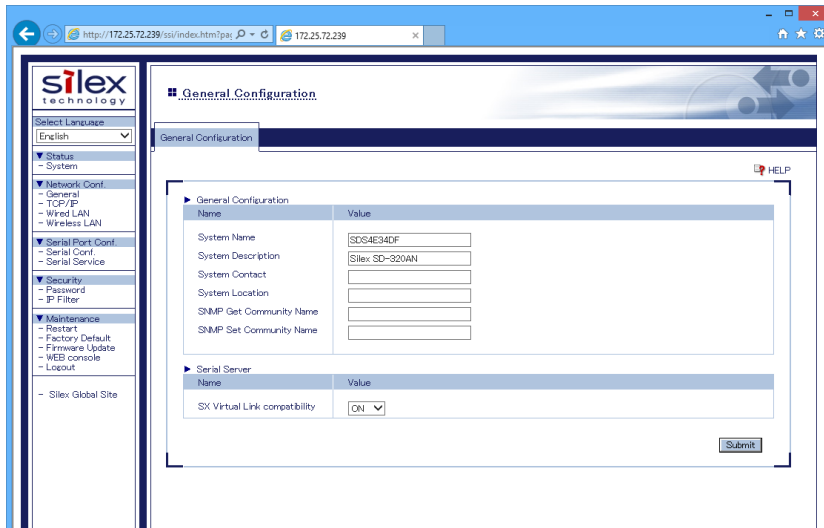

To take effect of the changes, restart SD-300/SD-320AN by clicking **Restart** from the left pane of the Web page.



#### Note

\* If you are to continue configuration on the other pages, you do not have to restart SD-300/SD-320AN. Restart it when all configuration is done.

## <<TCP/IP Configuration>>

In the left pane of the Web page, click **TCP/IP**.  
Enter or select the setting and click **Submit**.

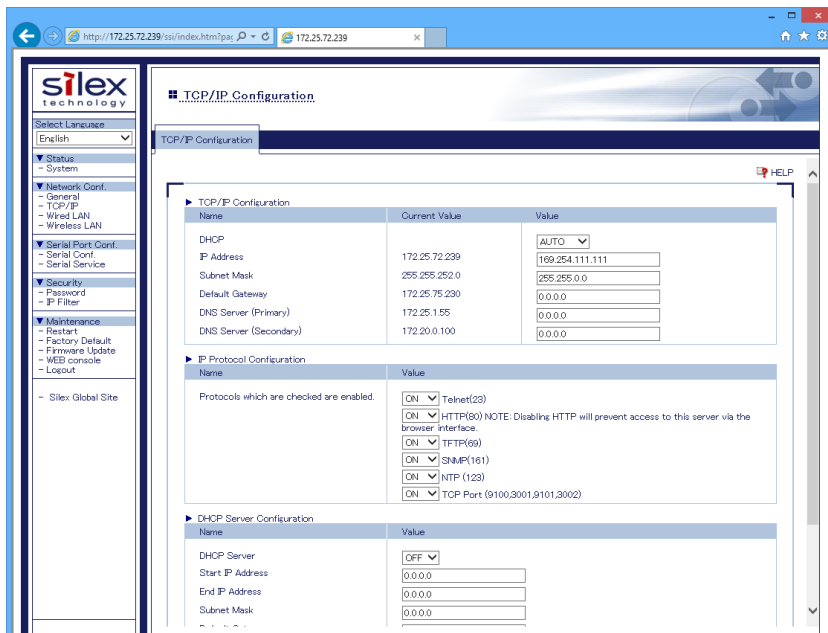

To take effect of the changes, restart SD-300/SD-320AN by clicking **Restart** from the left pane of the Web page.



### Note

\* If you are to continue configuration on the other pages, you do not have to restart SD-300/SD-320AN. Restart it when all configuration is done.

## <<Wired LAN Configuration>>

In the left pane of the Web page, click **Wired LAN**.  
Enter or select the setting and click **Submit**.

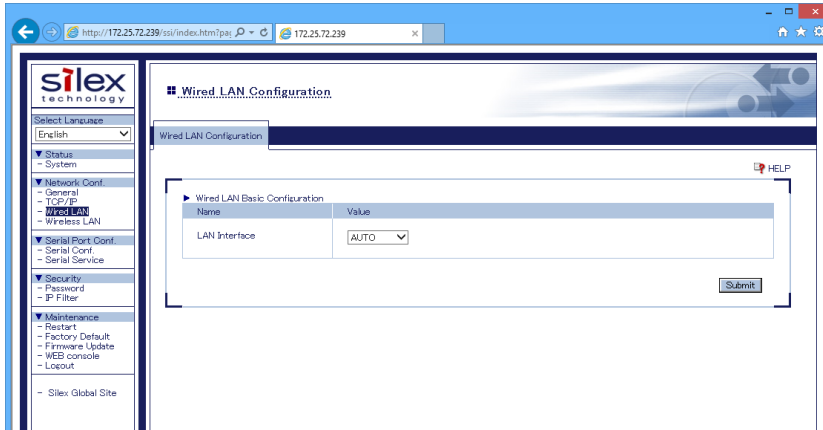

To take effect of the changes, restart SD-300/SD-320AN by clicking **Restart** from the left pane of the Web page.



### Note

\* If you are to continue configuration on the other pages, you do not have to restart SD-300/SD-320AN. Restart it when all configuration is done.

## <<Wired LAN (Wireless LAN Configuration)>>

In the left pane of the Web page, click **Wireless LAN**.  
Enter or select the setting and click **Submit**.

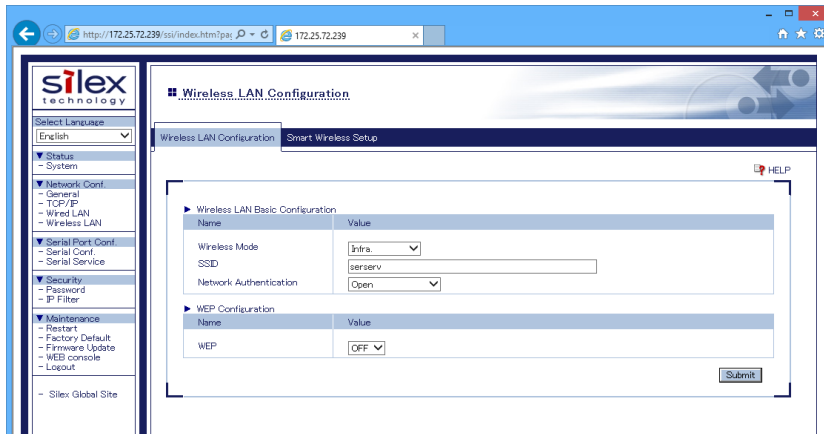

To take effect of the changes, restart SD-300/SD-320AN by clicking **Restart** from the left pane of the Web page.



### Note

\* If you are to continue configuration on the other pages, you do not have to restart SD-300/SD-320AN. Restart it when all configuration is done.

## &lt;&lt;Wired LAN (Smart Wireless Setup)&gt;&gt;

In the left pane of the Web page, click **Wireless LAN**.  
Enter or select the setting and click **Submit**.

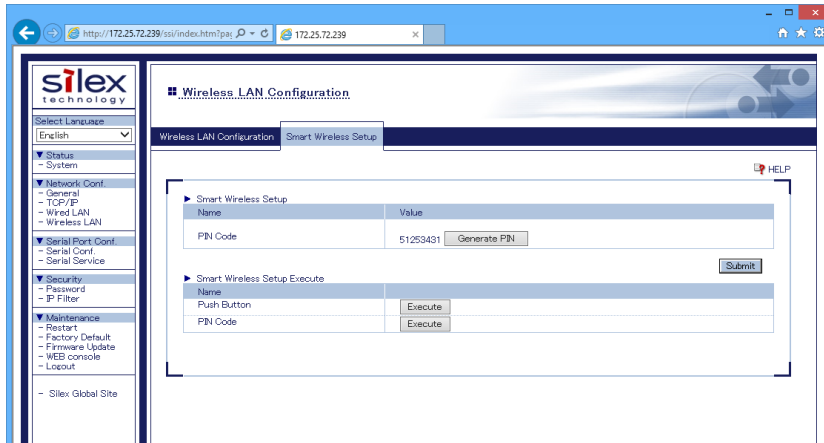

To take effect of the changes, restart SD-300/SD-320AN by clicking **Restart** from the left pane of the Web page.

**Note**

\* If you are to continue configuration on the other pages, you do not have to restart SD-300/SD-320AN. Restart it when all configuration is done.

## Configure Serial Port Settings

### <<Serial Configuration>>

In the left pane of the Web page, click **Serial Conf.**  
Enter or select the setting and click **Submit**.

To take effect of the changes, restart SD-300/SD-320AN by clicking **Restart** from the left pane of the Web page.



#### Note

\* If you are to continue configuration on the other pages, you do not have to restart SD-300/SD-320AN. Restart it when all configuration is done.

## &lt;&lt;Serial Service Configuration&gt;&gt;

In the left pane of the Web page, click **Serial Service**.  
Enter or select the setting and click **Submit**.

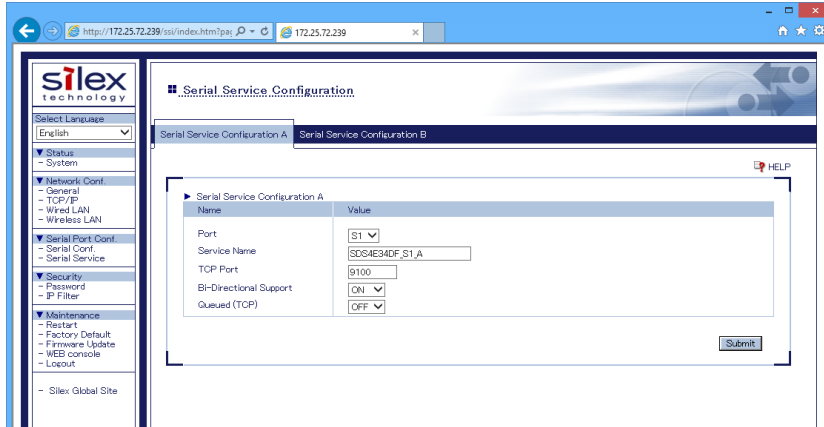

To take effect of the changes, restart SD-300/SD-320AN by clicking **Restart** from the left pane of the Web page.

**Note**

\* If you are to continue configuration on the other pages, you do not have to restart SD-300/SD-320AN. Restart it when all configuration is done.

## Configuration Item List

The SD-300/SD-320AN has the following configuration items:

### <<Network Configuration (General)>>

<b>General Configuration</b>	
Name	System Name
Details	Enter a unique name for the server. This name can be up to 32 ASCII printable characters.
Default	SDSxxxxxx (xxxxxx is a last 6 digits of Ethernet Address)
Name	System Description
Details	Enter a description for the server that may provide helpful information about the server. This description can be up to 64 ASCII printable characters.
Default	Silex xxxxxxxx (xxxxxx is product name)
Name	System Contact
Details	Enter the name of the person to contact for information about the server. This name can be up to 63 ASCII printable characters.
Default	NONE
Name	System Location
Details	Enter the location of the server. This location can be up to 63 ASCII printable characters.
Default	NONE
Name	SNMP Get Community Name
Details	Enter the name of the community to be used for fetching SNMP information from the server.
Default	public
Name	SNMP Set Community Name
Details	Enter the name of the community to be used for setting SNMP items in the server.
Default	public



- \* Notes on SNMP Get Community Name and SNMP Set Community Name
- When these items are displayed in the Web page, the current values will not be displayed in the entry fields.
  - When the configuration is updated without entering any settings, the configuration will not change.

<b>Serial Server</b>	
Name	SX Virtual Link compatibility
Details	Enable or disable the SX Virtual Link compatibility.
Default	ON

## &lt;&lt;Network Configuration (TCP/IP)&gt;&gt;

TCP/IP Configuration	
Name	DHCP
Details	Set IP address configuration method from AUTO, DHCP or STATIC. <b>AUTO</b> : Try to acquire IP address from DHCP server. Use configured address when it failed. <b>DHCP</b> : Try to acquire IP address from DHCP server. Unlike AUTO mode, keep trying until get IP address. <b>STATIC</b> : Use configured IP address.
Default	AUTO
Name	IP Address
Details	Set the IP address. The value must be 4 numbers separated by dots and expressed in the format [xxx.xxx.xxx.xxx].
Default	169.254.111.111
Name	Subnet Mask
Details	Set the subnet mask. The value must be 4 numbers separated by dots and expressed in the format [xxx.xxx.xxx.xxx]. When set to "0.0.0.0", a subnet mask appropriate for the IP address is automatically used.
Default	255.255.0.0
Name	Default Gateway
Details	Set the gateway address. The value must be 4 numbers separated by dots and expressed in the format [xxx.xxx.xxx.xxx]. Also, the gateway needs to be running in the same subnetwork as SD-300/SD-320AN. If "0.0.0.0" is set, this setting is disabled.
Default	0.0.0.0
Name	DNS Server (Primary)
Details	Set a primary DNS server address. When DHCP is enabled, the DNS address obtained from these servers will be given higher priority.
Default	0.0.0.0
Name	DNS Server (Secondary)
Details	Set a secondary DNS server address. When DHCP is enabled, the DNS address obtained from these servers will be given higher priority.
Default	0.0.0.0

<b>IP Protocol Configuration</b>	
Name	
Details	Each selection controls a TCP/IP based protocol. Set "ON" for a protocol to allow a remote host to access the server using that protocol. Set "OFF" if the protocol should not be available.
Default	All protocols ON

<b>DHCP Server Configuration</b>	
Name	DHCP Server
Details	Select ON/OFF the DHCP Server function.
Default	OFF
Name	Start IP Address
Details	Set the start IP Address for lease.
Default	0.0.0.0
Name	End IP Address
Details	Set the end IP Address for lease.
Default	0.0.0.0
Name	Subnet Mask
Details	Set the subnet mask for IP address range. If 0.0.0.0 (default value) is set, the subnet mask appropriate for the Start IP Address will automatically be used.
Default	0.0.0.0
Name	Default Gateway
Details	Set the gateway address. This is disabled if 0.0.0.0 (default value) is set.
Default	0.0.0.0
Name	Lease Time
Details	Set the lease time (Days/Hours/Minutes). When the setting is "0Days 0Hours 0Minutes", assigned lease time to client is 10days.
Default	10Days 0Hours 0Minutes

## &lt;&lt;Network Configuration (Wired LAN)&gt;&gt;

<b>Wired LAN Basic Configuration</b>	
Name	LAN Interface
Details	Select the physical network type. In most cases, AUTO is used. If the LINK lamp on your HUB does not light up when SD-300/SD-320AN is turned on, configure this setting to match that of the HUB.
Default	AUTO

## &lt;&lt;Network Configuration (Wireless LAN)&gt;&gt;

<b>Wireless LAN Basic Configuration</b>	
Name	Wireless Mode
Details	Select whether SD-300/SD-320AN will communicate with the wireless network in Infrastructure mode ( <b>Infra.</b> ) or in AccessPoint mode ( <b>AccessPoint</b> ).  <b>When using an Access Point:</b> Select "Infra.". SD-300/SD-320AN will communicate with a network device via the Access Point which has the same SSID as SD-300/SD-320AN.  <b>When using as an Access Point :</b> Select "AccessPoint". SD-300/SD-320AN operates as an Access Point.  * When using SD-300/SD-320AN in AccessPoint mode, the network authentication mode is limited to "Open" or "WPA-Personal/WPA2-Personal".
Default	Infra
Name	SSID
Details	Set an SSID. Up to 32 alphanumeric characters can be used. The SSID is an ID that logically distinguishes one wireless LAN network from another. When different SSIDs are used among wireless devices, they cannot communicate with each other even if they are running in the same area and channel.
Default	serserv
Name	Channel
Details	Set a channel. A channel needs to be selected only when running in AccessPoint mode. Wireless devices must share the same channel to communicate with each other on a wireless LAN. When a network device running with the same SSID but in a different channel is found, SD-300/SD-320AN automatically switches the channel to that of the device.
Default	11

Name	Network Authentication
Details	<p>Select the network authentication mode that will be used to connect to the Access Point.</p> <p>To ensure a secure network, it is recommended to use WPA/WPA2. For IEEE 802.11n, only AES can be used.</p> <p><b>Open (Open System)</b> Allows all access without authentication. For encryption mode, WEP can be used.</p> <p><b>WPA-Personal/WPA2-Personal</b> Uses PSK for network authentication. For encryption mode, AUTO is used for WPA-Personal and AES is used for WPA2-Personal. The encryption key will be generated by communicating with the Access Point using a Pre-Shared key. WEP key setting is not used for this mode.</p> <p><b>802.1X</b> Uses EAP for network authentication. For encryption mode, WEP can be used.</p> <p><b>WPA-Enterprise/WPA2-Enterprise</b> Uses EAP for network authentication. For encryption mode, AUTO/TKIP/AES can be selected. WEP key setting is not used for this mode.</p>
Default	Open

WEP Configuration	
Name	WEP
Details	Enable/Disable WEP encryption (ON / OFF).
Default	OFF
Name	Key Index
Details	Set the number of the WEP to be used as the default key (1-4).
Default	1
Name	WEP Key1-4
Details	<p>Set the WEP key for WEP encryption.</p> <p>Up to 4 WEP keys can be set. This setting must be the same as that of your Access Point or other devices you wish to connect to.</p> <p>A WEP key must be 26-digit hexadecimal characters, which consists of numbers (0-9) and English letters (A-F).</p>
Default	00000000000000000000000000000000

<b>WPA/WPA2 Configuration</b>	
Name	Encryption Mode
Details	Select the encryption mode that you wish to use for WPA/WPA2 authentication. This setting must be the same as that of your Access Point or other devices you wish to connect to.  Select one of the following: <b>AUTO:</b> Used for WPA. An appropriate encryption mode is automatically selected for the Access Point.  <b>AES :</b> Standard encryption mode used for WPA2.
Default	AUTO for WPA AES for WPA2
Name	Pre-Shared Key
Details	Set a Pre-Shared Key for WPA (8-63 character string or 64 hexadecimal characters).
Default	Device Server

<b>IEEE802.1X Authentication Configuration</b>	
Name	802.1X Authentication Type
Details	Select EAP method when 802.1X or WPA/WPA2-Enterprise is selected. Select one from LEAP, EAP-TLS, EAP-TTLS, PEAP or EAP-FAST.
Default	EAP-TTLS
Name	User Name in 802.1X
Details	Configure the user name used for EAP authentication
Default	anonymous
Name	Password in 802.1X
Details	Configure the password for EAP authentication when LEAP, EAP-TTLS,PEAP or EAP-FAST is selected.
Default	anonymous

<b>CA Certificate</b>	
Name	Current Setting
Details	Show currently installed Client Certificate information. Client certificate is required for EAP-TLS. If you want to delete an installed Certificate, check the [Delete] checkbox then push [Submit] button located at the far right bottom of the screen. [Generate Certificate] button can generate a self-signed Client Certificate. [Download Certificate] button can download the Client Certificate as a PEM-encoded X.509 file.
Default	Not Installed

Name	Certificate File
Details	Upload a Certificate file. If there is already a Certificate installed, it will be overwritten. File format must be PEM encoded X.509 format.
Default	NONE

**Client Certificate**

Name	Current Setting
Details	Show currently configured Secret Key information. Secret Key is paired with the Client Certificate. When you upload a Client Certificate, please make sure a matching Secret Key is also uploaded. When you generate a self-signed Client Certificate, a matching Secret Key is automatically generated. If you want to delete the installed Secret Key, check the [Delete] checkbox then push the [Submit] button located at the far right bottom of the screen.
Default	Not Installed

Name	Certificate File
Details	Upload a Secret Key file. If there is already a Certificate installed, it will be overwritten. File format must be PEM encoded RSA or PKCS8 format.
Default	NONE

**Client Certificate Secret Key File**

Name	Current Setting
Details	Show currently configured Secret Key information. Secret Key is paired with the Client Certificate. When you upload a Client Certificate, please make sure a matching Secret Key is also uploaded. When you generate a self-signed Client Certificate, a matching Secret Key is automatically generated. If you want to delete the installed Secret Key, check the [Delete] checkbox then push the [Submit] button located at the far right bottom of the screen.
Default	Not Installed

Name	Certificate File
Details	Upload a Secret Key file. If there is already a Certificate installed, it will be overwritten. File format must be PEM encoded RSA or PKCS8 format.
Default	NONE

Name	Password
Details	Enter the password of the Secret Key file. This password is what is set for the Secret Key file when it is created. When self-signed Client Certificate is used, password is automatically set.
Default	NONE

<b>Generate Self-Signed Certificate</b>	
Name	Generate Self-Signed Certificate
Details	<p>Generate self-signed Certificate. A self-signed Certificate is a Certificate which is not signed by Certificate Authority (CA). It is indeed a Certificate; however it cannot be verified its authenticity. Thus, it should not be used when a high level of security is really required. It is mainly used for test and temporally installation.</p> <p>Modify Certificate information then push [Submit] to generate self-signed Certificate. It will automatically go back to the Wireless configuration screen.</p>
Default	NONE

<b>Smart Wireless Setup</b>	
Name	PIN Code
Details	<p>Displays the PIN Code to be entered to your wireless router (Access Point) during the Smart Wireless Setup.</p> <p>A new PIN Code can be generated randomly by clicking the button.</p>
Default	-
Name	PIN Code
Details	<p>Displays the PIN Code to be entered to your wireless router (Access Point) during the Smart Wireless Setup.</p> <p>A new PIN Code can be generated randomly by clicking the button.</p>
Default	-



**Note**

\* The items displayed in the Wireless LAN Configuration page will differ depending on what option is selected at Network Authentication.

## &lt;&lt;Serial Port Configuration (Serial Configuration)&gt;&gt;

<b>I/O Port Configuration</b>	
Name	Port Name
Details	Port Name
Default	S1
Name	Port Type
Details	Port Type
Default	Serial
Name	Baud Rate
Details	Select the speed at which the port should send and receive data. (300, 600, 1200, 2400, 4800, 9600, 19200, 38400, 57600, 115200, 230400, 460800, 921600)
Default	115200
Name	Bit per character
Details	Select the number of bits per character. (7, 8)
Default	8
Name	Stop bits
Details	Select the number of stop bits after each character. (1, 2)
Default	1
Name	Parity
Details	Select the parity scheme for each character. (NONE, ODD, EVEN)
Default	NONE
Name	Flow control
Details	Select the flow control method. (NONE, XON/XOFF, RTS/CTS)
Default	NONE
Name	Console Mode String
Details	If this string is defined, input from the serial port is scanned. If a sequence matching this string is received, the serial port transitions to console mode. If non-printing characters are desired a string of hex bytes may be entered by starting the string with '\x'
Default	NONE

<b>Ecable Mode Configuration</b>	
Name	Ecable Mode
Details	If Ecable mode is enabled, the server will attempt to make a network connection to the remote device defined by the parameters below. When the connection is made, any data received from the serial port is sent to the remote device and any data from the remote device is sent to the serial port.
Default	Disabled
Name	Ecable I/O Mode
Details	Select the network protocol to be used for I/O to the remote host if Ecable mode is enabled.
Default	TCP
Name	Destination IP Address
Details	Enter the IP address of the destination device to which a connection will be made if Ecable mode is enabled. It can also be specified using the host name only when TCP mode is enabled.
Default	0.0.0.0
Name	Destination Port
Details	Enter the port on the destination device to which a connection will be made if Ecable mode is enabled.
Default	0
Name	Local Port
Details	In UDP mode, enter the port on the local server to which the remote client will send data if Ecable mode is enabled.
Default	0
Name	Connection attempt time
Details	Enter the time between Ecable connection attempts.
Default	30
Name	Connection attempt time unit
Details	Enter the time unit for Ecable connection attempt time.
Default	sec

## &lt;&lt;Serial Port Configuration (Serial Service)&gt;&gt;

<b>Port Service Configuration</b>	
Name	Port
Details	Specifies the physical port associated with the service.
Default	S1
Name	Service Name
Details	Specifies the name of the service. Normally, you do not need to modify this field.
Default	SDSxxxxxx_S1_A for port service setting A SDSxxxxxx_S1_B for port service setting B (xxxxxx is a last 6 digits of Ethernet Address)
Name	TCP Port
Details	If non-zero, defines a TCP port to be used for connection to this service.
Default	9100 for port service setting A 3001 for port service setting B
Name	Bi-Directional Support
Details	If set to ON, the service will send data back from the attached device to the network. Normally you should not need to change this.
Default	ON
Name	Queued (TCP)
Details	If set to ON, and if a raw TCP port is defined, the server will queue jobs sent to that port. If set to OFF, jobs will be rejected if the server is currently busy with another job.
Default	OFF

## &lt;&lt;Security (Password)&gt;&gt;

Name	New Password
Details	Set an administrative password as an ASCII string (up to 16 characters). This password is used as authentication for changing the settings from the Web page.
Default	access

## &lt;&lt;Security (IP Filter)&gt;&gt;

<b>Add New Range.</b>	
Name	Starting Address Ending Address Add
Details	To add a range of remote hosts, enter the starting (low) and ending (high) IP addresses in the fields provided, then click the 'Add' button. All hosts with IP address between the start and end addresses, inclusive, will be allowed access to this server.
Default	0.0.0.0

<b>Manage Configured Ranges.</b>	
Name	Remove
Details	To remove a range of allowed hosts, select the target range from the list and then click the 'Remove' button. If you remove the range containing the computer from which you are accessing the server, you will not be able to perform any further configuration of the server. If all ranges are removed, all hosts are allowed access to the server.
Default	NONE

## 7-2. Security Settings

### Change the Password

1. Access the Web page of SD-300/SD-320AN.



\* For details on how to access the Web page, refer to **Access the SD-300/SD-320AN Web Page**.

#### Note

2. In the left pane of the Web page, click **Password**.

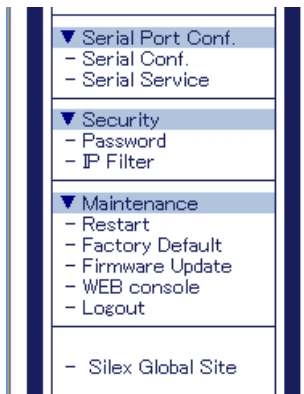

3. The Password Configuration page is displayed.  
Enter the password to **New Password** and click **Submit**.

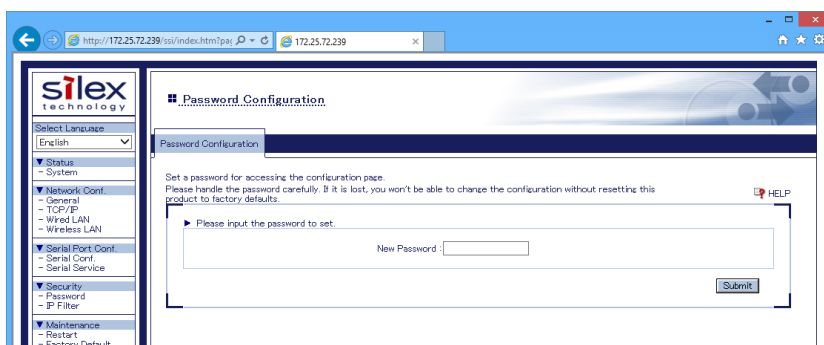

#### TIP

\* Please handle the password carefully. If the password is lost, you will not be able to change the settings again unless SD-300/SD-320AN is reset to the factory default setting.

- To take effect of the changes, restart SD-300/SD-320AN by clicking **Restart** from the left pane of the Web page.



\* If you are to continue configuration on the other pages, you do not have to restart SD-300/SD-320AN. Restart it when all configuration is done.

**Note**

## Allow Communication Only from a Particular PC

### <<About IP Filter Feature>>

If this feature is used, SD-300/SD-320AN allows accesses only from the registered IP address ranges.

Up to 4 IP address ranges can be specified.

### <<IP Filter Settings>>

IP filter settings can be configured from the Web page.

The example below shows how to allow communications only from the IP address range "172.25.72.10" - "172.25.72.20":

- Access the Web page of SD-300/SD-320AN.



\* For details on how to access the Web page, refer to **Access the SD-300/SD-320AN Web Page**.

**Note**

- In the left pane of the Web page, click **IP Filter**.

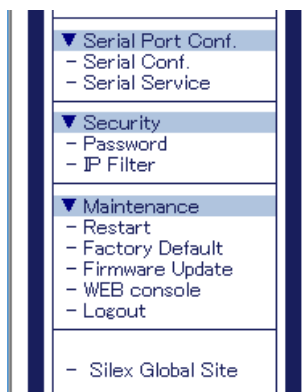

3. Enter the **Starting Address** and **Ending Address** and click Add (up to 4 address ranges can be registered).

In this example, 172.25.72.10 is entered as the start address and 172.25.72.20 is entered as the end address to allow communication from that range.

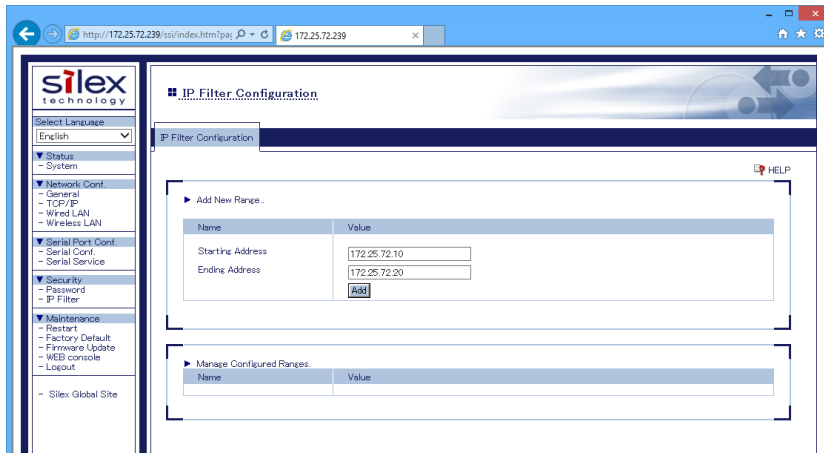

\* If the address range is deleted which includes the IP address of the computer which is currently accessing SD-300/SD-320AN, the communication for that computer will be lost. It will not recover until the IP filter feature is disabled.



**Note**

\* By deleting all the registered address ranges from **Manage Configured Ranges**, you can disable the IP filter feature as well as allow accesses from all IP addresses.

4. To take effect of the changes, restart SD-300/SD-320AN by clicking **Restart** from the left pane of the Web page.



**Note**

\* If you are to continue configuration on the other pages, you do not have to restart SD-300/SD-320AN. Restart it when all configuration is done.

## 7-3. Maintenance

### Reboot SD-300/SD-320AN



\* Before you start, please make sure that no PCs are currently linked.

**TIP**

#### <<Manual reboot at the unit side>>

1. Unplug the AC plug of SD-300/SD-320AN from the power outlet.
2. Insert the AC plug back into the power outlet again.
3. The reboot will be complete in 30 seconds.

#### <<Remote reboot from the Web page>>

1. Access the Web page of SD-300/SD-320AN.



\* For details on how to access the Web page, refer to **Access the SD-300/SD-320AN Web Page**.

**Note**

2. In the left pane of the Web page, click **Restart**.

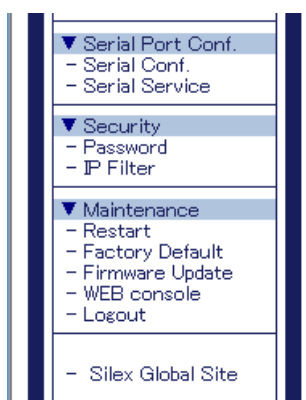

- The Restart page is displayed.  
Click **Yes**.

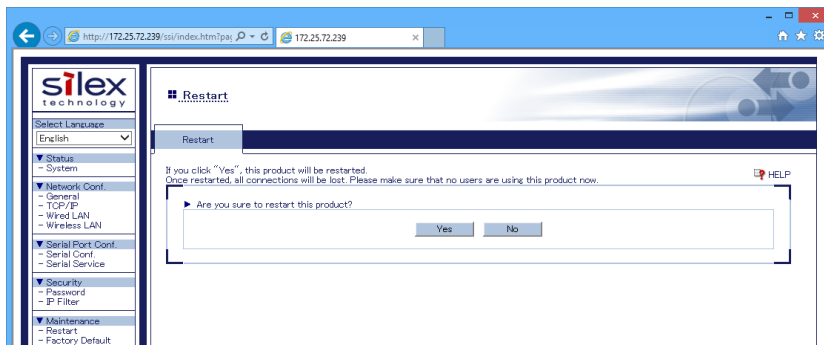

- The reboot will begin.

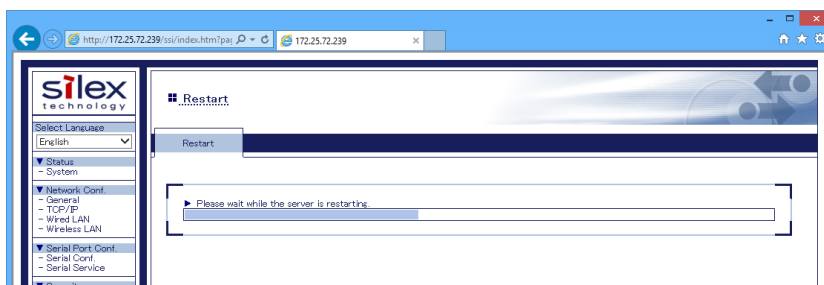

- When the system status page is displayed, the reboot is completed.  
Finish the Web browser.

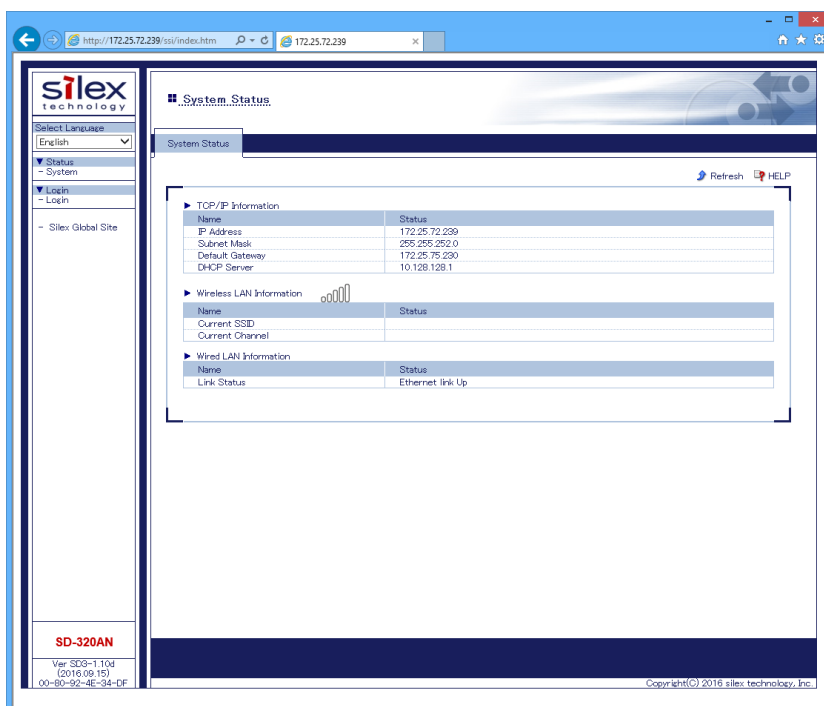

## Reset to Factory Default

If SD-300/SD-320AN has been used in a particular network and you wish to change the settings to use it for another network, please initialize SD-300/SD-320AN first according to the instructions below:

### <<Reset using the RESET switch on SD-300/SD-320AN>>



- \* It is recommended to take notes of the current settings. You cannot restore it once the factory default configuration is complete.
- \* Before you start, please make sure that no PCs are currently linked.
- \* Do not turn off SD-300/SD-320AN while resetting to factory default.
- \* Do not press the push switch on the top when turning on SD-300/SD-320AN again after it was reset to the factory default settings.
- \* The following settings will remain even after finishing the factory default configuration.
  - \* Network Conf. - General - System Description
  - \* Network Conf. - Wired LAN - LAN Interface

1. Press and hold the push switch with a fine tipped object such as a pen or pencil when the SD-300/SD-320AN is powered on. Keep pressing it for 5 or more seconds.

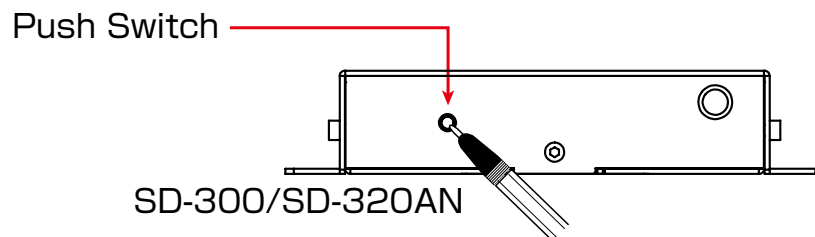

2. The factory default configuration will begin when the push switch is released.
3. When the factory default configuration is completed, the SD-300/SD-320AN will automatically be restarted **after the orange LED turns off**.

## <<Reset from the Web page>>

1. Access the Web page of SD-300/SD-320AN.



### Note

\* For details on how to access the Web page, refer to **Access the SD-300/SD-320AN Web Page**.

2. In the left pane of the Web page, click **Factory Default**.

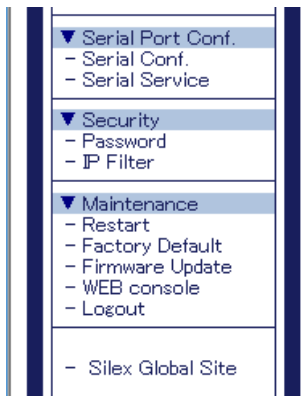

3. The factory default configuration page is displayed. Click **Yes**.

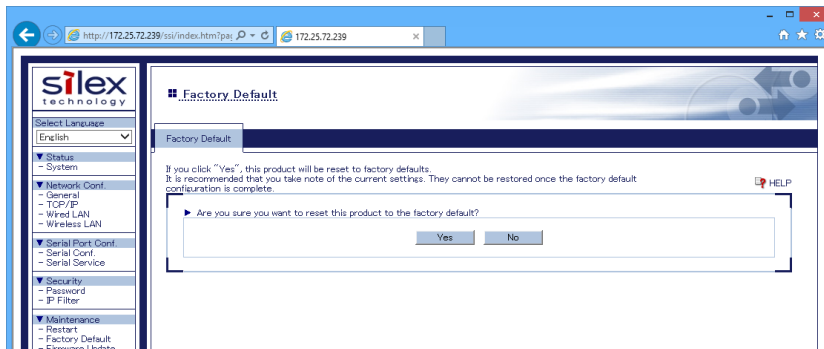

4. A confirmation message is displayed. Click **OK** to start the factory default configuration.

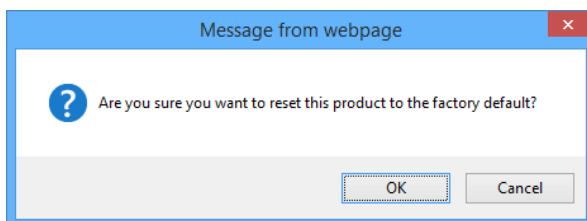

- The Restart page is displayed.  
Click Yes.

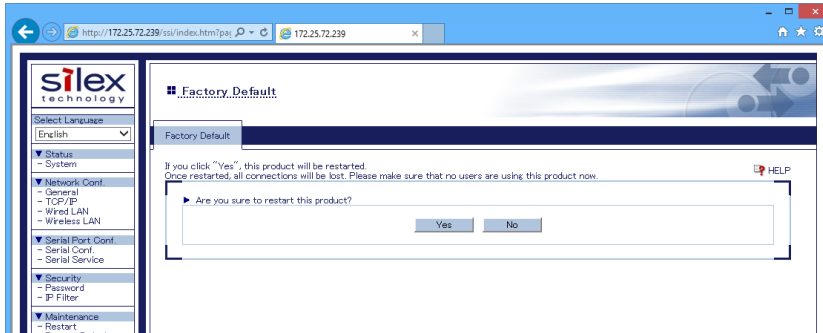

- The reboot will begin.

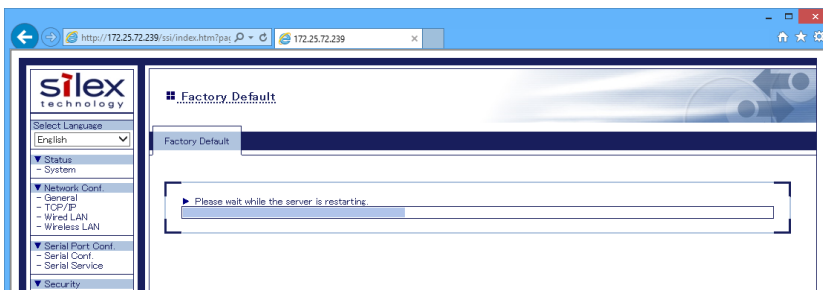

- When the system status page is displayed, the factory default configuration is completed.  
Finish the Web browser.

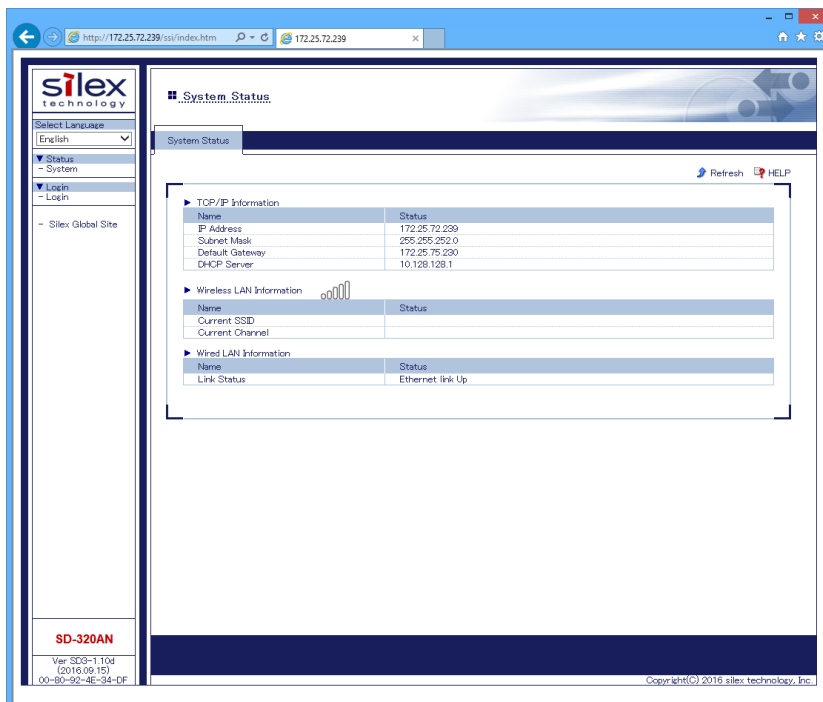

## Update Firmware

### <<Download the latest firmware file>>

Please download the latest firmware file from our website.  
For how to download the firmware file, refer to Download the Utilities.

### <<Update the firmware>>



**TIP**

- \* Before you start, please make sure that no PCs are currently linked.
- \* Do not turn off SD-300/SD-320AN while the firmware update is in process.
- \* It is recommended to take notes of the current settings. You cannot restore it once the firmware update is complete.

### 1. Access the Web page of SD-300/SD-320AN.



**Note**

- \* For details on how to access the Web page, refer to **Access the SD-300/SD-320AN Web Page**.

### 2. In the left pane of the Web page, click **Firmware Update**.

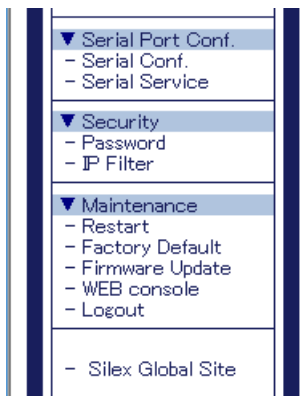

- The Firmware Update page is displayed.  
Click **Browse** to select the firmware file to be loaded to SD-300/SD-320AN.  
Check that the file name is displayed in **New firmware** field and click **Update**.

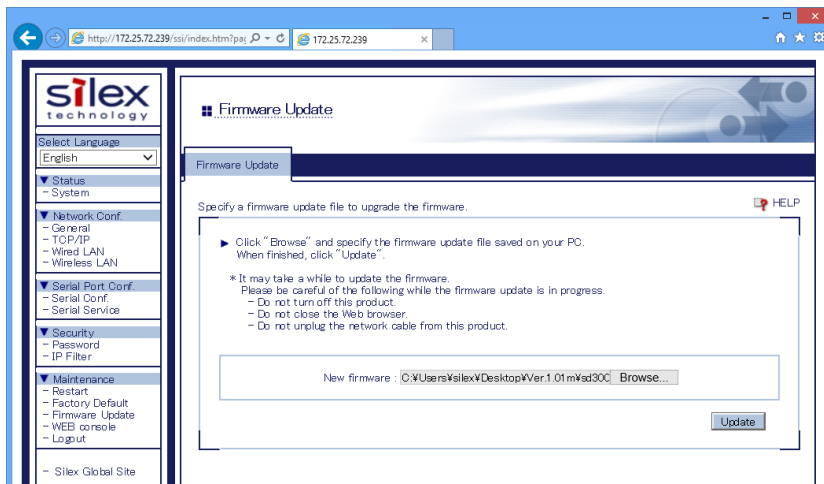

- A confirmation message is displayed. Click OK.

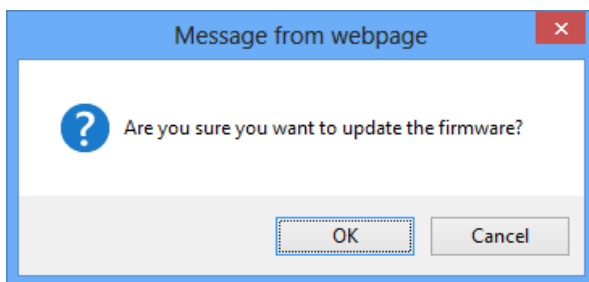

- The firmware update will begin.

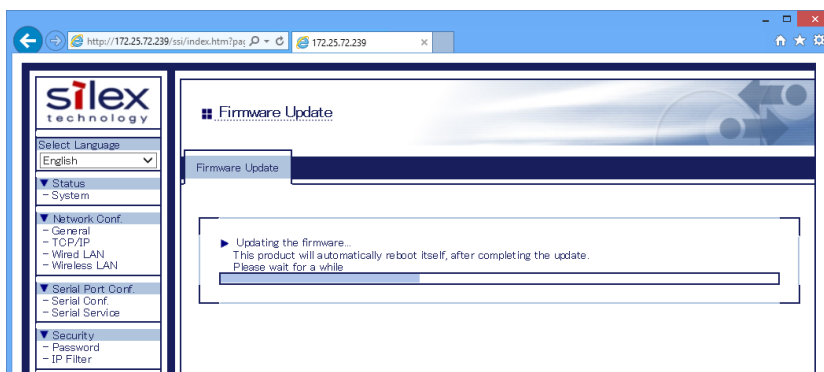

- When the system status page is displayed, the firmware update is completed. See the bottom left of the page and check that the version information is changed.

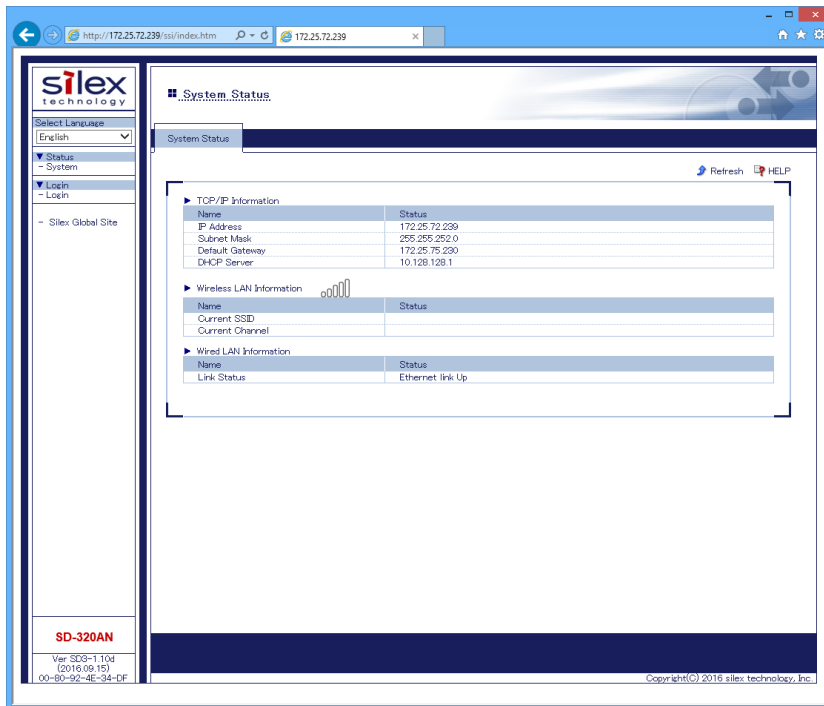

- Finish the Web browser.

## 7-4. Uninstall Application

The SX Virtual Link for Serial Device Server can be deleted from Uninstall a program in the Control Panel.



\* To uninstall SX Virtual Link for Serial Device Server, administrator privilege is required.

**TIP**

1. Click **Control Panel - Uninstall a program**.
2. Select **SX Virtual Link for Serial Device Server** from the list and click **Uninstall**.

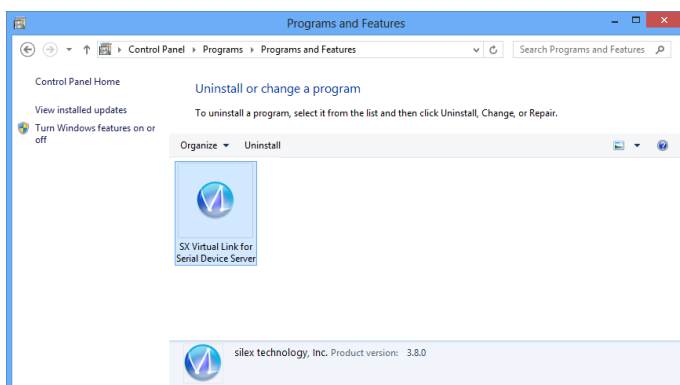

\* If the User Account Control message is displayed, click **Continue**.

**TIP**

3. A confirmation message is displayed. Click Yes to start the uninstallation.

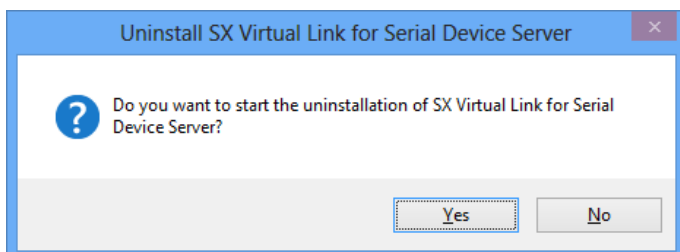

4. When a screen below is displayed, click Finish.

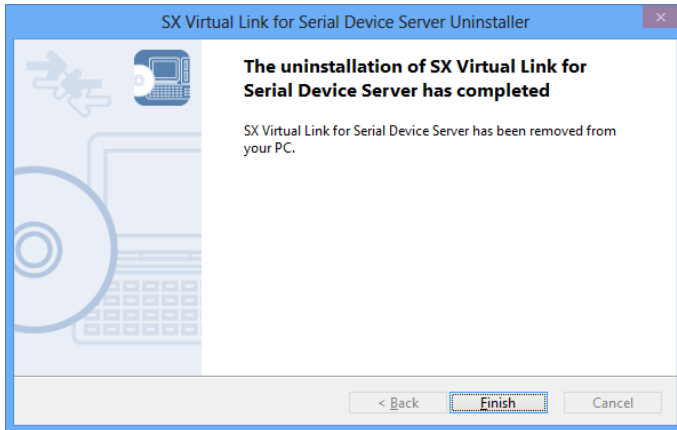

SX Virtual Link for Serial Device Server has been uninstalled.

# 8. Troubleshooting

---

## 8-1. Problems During the Setup

### **SD-300/SD-320AN is not displayed in the search result of Serial Device Server Setup.**

When SD-300/SD-320AN is not displayed in the search result of Serial Device Server Setup, the cause need to be determined from the installation status, network environment, and status of PC used for the configuration of SD-300/SD-320AN. When using a wireless LAN product, please also refer to the **Wireless LAN Problems** as described later.

SD-300/SD-320AN or the Ethernet Hub SD-300/SD-320AN is connected to may have a problem regarding connection, power transmission, or operation.

Solution	Please check the LED status of SD-300/SD-320AN and the Ethernet Hub SD-300/SD-320AN is connected to. If the LED indicates improper status, replace the AC plug and other cables, and reboot the connected devices.
----------	--

The startup of SD-300/SD-320AN may not have been completed.

Solution	It takes up to 30sec for SD-300/SD-320AN to get ready after it is powered on. Please wait until SD-300/SD-320AN becomes ready and then click the Search in the Serial Device Server Setup.
----------	--

SD-300/SD-320AN may not be in the same network segment (environment without a router) as your PC.

Solution	During the initial configuration, place SD-300/SD-320AN and PC in the same network segment.
----------	---

If SD-300/SD-320AN has been used in another network, it may have the settings not allowing the communication with your PC.

Solution	Please reset SD-300/SD-320AN to the factory default setting. Refer to <b>Reset to Factory Default</b> for details.
----------	--

Security software such as firewall may be interrupting the communication with SD-300/SD-320AN.

Solution	Please abort your security software. Refer to FAQ in our website ( <a href="http://www.silexamerica.com/">http://www.silexamerica.com/</a> ) for details on how to abort security software.
----------	---

### Communication error occurs when configuring with Serial Device Server Setup.

When a communication error occurs during Serial Device Server Setup, the cause needs to be determined from the settings of the PC used for the configuration.

SD-300/SD-320AN may not be in the same network segment (environment without a router) as your PC.

Solution	During the initial configuration, place SD-300/SD-320AN and PC in the same network segment.
----------	---

In the environment where there is DHCP server, the DHCP server may have configured the IP address of the different segment to a PC.

Solution	Please select Obtain an IP address automatically at Internet Protocol (TCP/IP) Properties of the PC. Otherwise connect the PC and SD-300/SD-320AN to the standalone Ethernet Hub and see how it works.
----------	---

If SD-300/SD-320AN has been used in another network, it may have the settings not allowing the communication with your PC.

Solution	Please reset SD-300/SD-320AN to the factory default setting. <b>Refer to Reset to Factory Default</b> for details.
----------	--

### How should I determine the way to assign an IP address to SD-300/SD-320AN?

There are two ways to assign an IP address to SD-300/SD-320AN; one is to Get IP address automatically from DHCP server and the other is to Assign IP address manually. Choose the way to assign an IP address according to your environment.

When there is a DHCP server in the network environment:

Solution	You can use Get IP address automatically from DHCP server. As SD-300/SD-320AN is set by default to Get IP address automatically, SD-300/SD-320AN will obtain an IP address appropriate to your network environment from the DHCP server just by powering up SD-300/SD-320AN. Refer to <b>Reset to Factory Default</b> for details on how to reset SD-300/SD-320AN to the factory default settings.
----------	---

When there is no DHCP server in the network environment, or when you do not prefer getting an IP address from DHCP server:

**Solution** Please use Assign IP address manually. Keep in mind of the following points regarding the IP address to assign to SD-300/SD-320AN.

- \* Assign an IP address unique in the network.
- \* Assign an IP address that has the same address class as the PC that will use SD-300/SD-320AN.  
e.g. When an IP address of the PC is "192.168.0.xx", assign an address such as "192.168.0.100" that is not used by other network devices.

(Tips about the IP address)

- \* An IP address is a unique number for identifying network devices. An IP address is indicated with four numbers divided by a period (.), for example "192.168.0.1". The integer from 0-255 is used for each number.
- \* An IP address is, depending on the number assigned, categorized to 3 classes below.
- \* Numbers making up the IP address are either network numbers indicating network, or host numbers indicating each network device; each number indicates the different meaning based on the IP address class. Each class is categorized as the following diagram which is indicating a network number as n, and a host number as u. An IP address with the same network number must be assigned to the network devices in the same network segment.
- \* There is an address range in the IP address called the private address that could be used freely. In the LAN environment not directly connected to the internet, an IP address is assigned within the range of the private address.

First 1 digits in IP address	Class	Definition of IP address n: network number u: host number	Size of the network to be used	Private address
0 - 127	A	n.u.u.u	Large network	10.0.0.0 - 10.255.255.255
128 - 191	B	n.n.u.u	Mid-size network	172.16.0.0 - 172.31.255.255
192 - 223	C	n.n.n.u	Small network	192.168.0.0 - 192.168.255.255

**An error message is displayed when installing SX Virtual Link for Serial Device Server.**

An older version of SX Virtual Link for Serial Device Server may already be installed on the PC.

**Solution** If SX Virtual Link for Serial Device Server Ver.3.3.0 is installed on your PC, you cannot install the newer version of SX Virtual Link for Serial Device Server. Remove the older version first and try installing the newer version again.

**Is it possible to install "SX Virtual Link" (USB device management utility) and "SX Virtual Link for Serial Device Server" (serial device management utility) on the same PC?**

It is possible to install "SX Virtual Link" and "SX Virtual Link for Serial Device Server" on the same PC. However, please note that "SX Virtual Link for Serial Device Server" can replace "SX Virtual Link". You can manage both USB devices and serial devices, including discovering, linking to and unlinking from them using "SX Virtual Link for Serial Device Server".

Solution	You can install "SX Virtual Link for Serial Device Server" on a PC which has "SX Virtual Link" already installed. However, if "SX Virtual Link" is installed on a PC which has "SX Virtual Link for Serial Device Server" already installed, you will not be able to link to serial devices. Remember that "SX Virtual Link for Serial Device Server" can be used to discover, link to and unlink from both USB devices and serial devices. If "SX Virtual Link for Serial Device Server" is installed on your PC, do not install "SX Virtual Link".
----------	---

## 8-2. Problems While Using SD-300/SD-320AN

### Serial devices are not displayed or temporarily displayed in SX Virtual Link for Serial Device Server.

If serial devices are not displayed in SX Virtual Link for Serial Device Server, you need to check the cable connection as well as the network settings between SD-300/SD-320AN and your PC.

SD-300/SD-320AN or the Ethernet Hub SD-300/SD-320AN is connected to may have a problem regarding connection, power transmission or operation.

Solution	Please check the LED status of SD-300/SD-320AN and the Ethernet Hub SD-300/SD-320AN is connected to. If the LED indicates improper status, replace the AC plug and other cables, and reboot the connected devices.
----------	--

The startup of SD-300/SD-320AN may not have been completed.

Solution	It takes up to 30sec for SD-300/SD-320AN to get ready after it is powered on. Please wait until SD-300/SD-320AN becomes ready, and then click the Refresh button  in SX Virtual Link for Serial Device Server again.
----------	--

Security software such as firewall may be interrupting the communication with SD-300/SD-320AN.

Solution	Please add SX Virtual Link for Serial Device Server to the exception list in your security software. Please refer to the FAQ on our website ( <a href="http://www.silexamerica.com/">http://www.silexamerica.com/</a> ) for details on adding an application to the exception list.
----------	---

An IP address unable to communicate with your PC may be assigned to SD-300/SD-320AN.

Solution	<p>First, check the IP Address of your PC. To check the IP Address, use the Windows Command Prompt.</p> <ol style="list-style-type: none"> <li>1. Select <b>Start - All Programs - Accessories - Command Prompt</b>.</li> <li>2. When the Command Prompt is started, execute the ipconfig command.</li> </ol>
----------	---

Example of executing the **ipconfig** command

```
Microsoft Windows [Version 6.0.6001]
Copyright (C) 2006 Microsoft Corporation. All rights reserved.

C:\Users\username>ipconfig (Press Enter)

Windows IP Configuration

Ethernet adapter Local Area Connection:

    Connection-specific DNS Suffix . :
    IPv6 Address . . . . . : :::::
    Temporary IPv6 Address . . . . . : :::::
    IPv4 Address. . . . . : 192.168.20.10 (IP Address of PC)
    Subnet Mask . . . . . : 255.255.255.0
    Default Gateway . . . . . :
```

Check that the IP Address of the PC is a proper address for communicating with the IP Address of SD-300/SD-320AN.

If the PC and SD-300/SD-320AN are in the same network segment but use a different network number in their addresses, you need to change either the address of the PC or SD-300/SD-320AN. Also, if there is a router between the PC and SD-300/SD-320AN, check that the default gateway address is properly configured.

The IP address assigned to SD-300/SD-320AN may be in use by another network device.

**Solution**

First, turn off SD-300/SD-320AN and open the Windows Command Prompt. Ping the IP address of SD-300/SD-320AN.

1. Select **Start - All Programs - Accessories - Command Prompt**.
2. When the Command Prompt appears, execute the **ping** command.

Example of executing the ping command when the IP address of SD-300/SD-320AN is 192.168.20.20

```
Microsoft Windows [Version 6.0.6001]
Copyright (C) 2006 Microsoft Corporation. All rights reserved.

C:\Users\username>ping 192.168.20.20 (Press Enter)

Pinging 192.168.20.20 with 32 bytes of data:

(When there is a reply)
Reply from 192.168.20.20: bytes=32 time<1ms TTL=128
Reply from 192.168.20.20: bytes=32 time<1ms TTL=128
Reply from 192.168.20.20: bytes=32 time<1ms TTL=128
Reply from 192.168.20.20: bytes=32 time<1ms TTL=128

(When there is no reply)
Reply from XXX.XXX.XXX.XXX: Destination host unreachable.
Reply from XXX.XXX.XXX.XXX: Destination host unreachable.
Reply from XXX.XXX.XXX.XXX: Destination host unreachable.
Reply from XXX.XXX.XXX.XXX: Destination host unreachable.
```

If there is a reply while SD-300/SD-320AN is turned off, it means there is another network device using the same IP address as SD-300/SD-320AN. In such a case, change the IP address of either SD-300/SD-320AN or the other network device.

A serial cable used to connect SD-300/SD-320AN and a serial device may not be plugged in correctly.

**Solution**

Please check that the serial cable is properly plugged into SD-300/SD-320AN and the serial device. If you have a spare serial cable, replace the cable.

<b>I cannot communicate with a serial device.</b>
---

If you cannot communicate with the serial device connected to SD-300/SD-320AN, you need to check the communication settings on SD-300/SD-320AN and the serial communication software.

A serial cable used to connect SD-300/SD-320AN and a serial device may not be plugged in correctly.	
---	--

Solution	Please check that the serial cable is properly plugged into SD-300/SD-320AN and the serial device. If you have a spare serial cable, replace the cable.
----------	---

Serial communication settings may differ between the serial device and serial communication software.	
---	--

Solution	When you are using SX Virtual Link for Serial Device Server to communicate with a serial device, the serial communication settings may differ between the serial device and serial communication software. If the serial communication settings are different between them, you may not be able to communicate with the serial device. Also, output serial data may not be transferred correctly. Check the settings on the serial communication software and match it with those used in the serial device. For details on how to change the settings on your serial communication software, refer to the operation manual that came with it.
----------	---

Serial communication settings may differ between SD-300/SD-320AN and the serial device.	
---	--

Solution	If you are using Ecable Mode or Raw TCP Connection Mode to communicate with a serial device, the serial communication settings may differ between SD-300/SD-320AN and the serial device. If the serial communication settings are different between them, you may not be able to communicate with the serial device. Also, output serial data may not be transferred correctly. You can change the serial communication settings of SD-300/SD-320AN from the Web page. For details on how to change the settings on the Web page, refer to <b>Configure Serial Port Settings</b> or <b>Configuration Item List - Serial Port Configuration</b> .
----------	---

When using SD-300/SD-320AN in Ecable Mode, the destination IP address or TCP port number settings may be incorrect.	
---	--

Solution	In Ecable Mode, two SD-300/SD-320AN's must be configured with the proper IP addresses to communicate with each other, and the same TCP port number should be used for both. If these settings are different between them, serial communication may fail due to a network connection not being established. For detailed settings to use SD-300/SD-320AN in <b>Ecable Mode</b> , refer to <b>Ecable Mode (Link to the Registered Device) - 2. Before You Begin</b> .
----------	--

When using SD-300/SD-320AN in Raw TCP Connection Mode, the TCP port number may be different between SD-300/SD-320AN and the application program.	
--	--

Solution	In Raw TCP Connection Mode, SD-300/SD-320AN and the application program should be configured with the same TCP port number. If this setting is different between them, serial communication may fail due to a network connection not being established. For detailed settings to use SD-300/SD-320AN in <b>Raw TCP Connection Mode</b> , refer to <b>Raw TCP Connection Mode (Link to Serial Device Using TCP Raw Port) - 2. Before You Begin</b> .
----------	--

## SD-320AN turns on in a wireless LAN mode although it is connected to a wired LAN using a network cable.

If SD-320AN is powered on while it is connected to a 10BASE-T Ethernet HUB using a network cable, SD-320AN could turn on in a wireless LAN mode.

**Solution** Extend the amount of time to recognize a wired LAN so that SD-320AN can turn on in a wired LAN mode.  
The instructions below provide an example of how to set "5 sec" for the amount of time to recognize a wired LAN.

1. Access the SD-320AN Web page and click **WEB console** from the left menu. Enter the **SET NW STARTDELAY 5** to the field and click **Enter**.

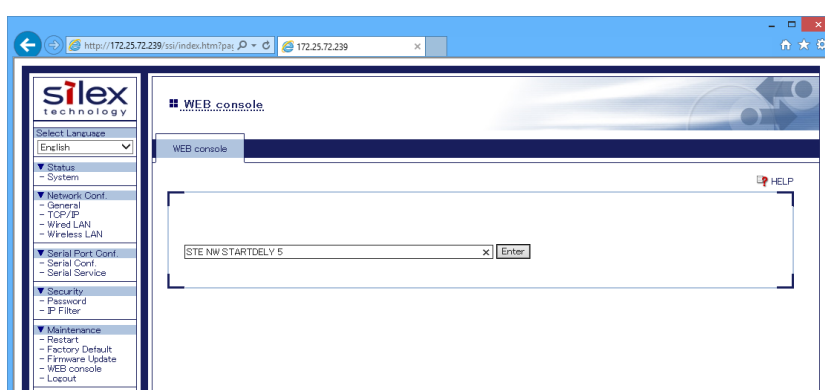

2. Enter **SAVE** to the field and click **Enter**. To check the setting, enter **SHOW NW STARTDELAY** to the field and click **Enter**. The current setting is displayed.
3. When the configuration is completed, click **Restart** under **Maintenance** to restart SD-320AN.

## 8-3. Wireless LAN Problems (SD-320AN Only)

### Is there any information I should check before configuring SD-320AN?

To connect SD-320AN in Infrastructure mode, please check the following configuration information of the Access Point.

SSID (ESSID)	ID to identify the Access Point.
Encryption requirements	Whether encrypted communication with the Access Point is required or not.
Encryption mode	Encryption type (WEP, WPA, WPA2 and etc.) in case it is required.
Encryption key	Key necessary for encryption. WEP key, when using WEP encryption. Pre-Shared Key, when using WPA/WPA2 encryption.
Key index	Which key from 1 to 4 is enabled, when using a WEP key.
Other security function	Information for a security function configured to an Access Point. e.g. MAC address filter if a security function is configured to the Access Point, configuration of the Access Point needs to be changed to allow the communication with SD-320AN.

### Does SD-320AN support the auto-connection function of the Access Point?

**\* SD-320AN does not support proprietary auto-connection function of the Access Point implemented by each manufacturer.**

If the environment setting of an Access Point has been set using the auto-connection function of the Access Point, please check the configuration information listed in the previous section. If there is any unclear information, configuration of the Access Point needs to be changed manually.

### SD-320AN can be used and connected via wired LAN, but cannot be communicated via wireless LAN.

Please check the operation status and configuration of SD-320AN.

SD-320AN may have been started with wired LAN mode.

Solution	When the network cable is connected to SD-320AN, it starts with wired LAN mode. If an Ethernet cable is connected to SD-320AN, unplug the network cable and restart SD-320AN.
----------	---

Wireless LAN configuration of SD-320AN may not be suitable to your environment.

Solution	Connect a network cable to SD-320AN and check the wireless LAN settings.
----------	--

### Connection is interrupted and disconnected.

If your wireless LAN is interrupted and disconnected, SD-320AN may be installed into a location subject to weaker radio wave signals.

Solution	Please reconsider the location of installation and condition of use.
----------	--

