



Questo manuale d'istruzione è fornito da trovaprezzi.it. Scopri tutte le offerte per [SPC Fortune 2 Pocket Edition](#) o cerca il tuo prodotto tra le [migliori offerte di Cellulari e Smartphone](#)



Questo manuale d'istruzione è fornito da trovaprezzi.it. Scopri tutte le offerte per [SPC Fortune 2 Pocket Edition](#) o cerca il tuo prodotto tra le [migliori offerte di Cellulari e Smartphone](#)



# SPC FORTUNE 2

# TABLE OF CONTENTS

1. Introduction -----	3
2. Position of the controls -----	3
3. Useful tips -----	4
4. First steps before switching on -----	4
5. Switch on telephone -----	6
6. Unlock or turn on the phone screen -----	7
7. Call -----	8
a. Call a contact from the address book	
b. Call from history	
c. Accept / reject call	
d. Answering and hanging up calls by opening/closing the cover	
e. During a call	
f. Display for missed calls	
8. Speed dial -----	9
a. Direct memory	
b. Indirect storage	
9. Ringtones, sounds and volume -----	9
10. Address book -----	10
a. View address book	
b. Quick search	
c. Contact options	
d. Add a contact	
11. Messages -----	10
a. Receive new message	
b. Write a message	
12. SOS Button -----	11
a. Configuration of the SOS button	
b. Using the SOS button	
13. Smart Help -----	13
a. What is Smart Help?	
b. Remote configuration	
c. Intelligent ringtone	
d. Smart notifications	
14. Multimedia -----	15
a. Cameras	
b. Images	
c. Video camera	
d. Music player	
e. Sound recording	
f. Radio	
g. File manager	
15. Setting -----	17

16. Battery and charging -----	18
17. Other functions / tool menu -----	20
a. Bluetooth	
b. Calculator	
c. Calendar	
d. Alarm	
e. World clock	
18. Flashlight -----	21
19. Technical data -----	21
20. Frequently Asked Questions -----	21

## 1. INTRODUCTION

This document is a user manual for the FORTUNE 2 push-button phone from SPC. Here you will find information about the first steps you need to take in order to use your cell phone and about its various functions.

## 2. POSITION OF THE CONTROLS

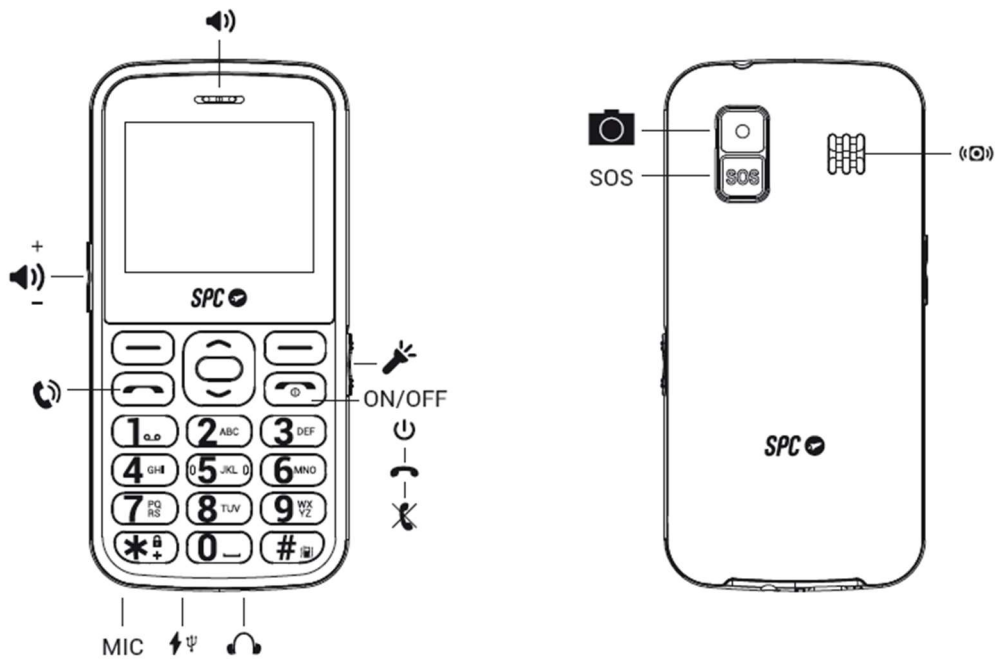

## 3. USEFUL TIPS

- To access the main menu, open the flap and press the upper left button (**PONER ICONO**) while the phone is in standby mode.
- To navigate through the main menu and the various submenus, press the edges of the middle round button up or down.
- The top left button performs the action shown at the bottom left of the screen.
- The top right button performs the action shown at the bottom right of the screen.
- To confirm a selection, press the middle OK button or the corresponding upper button.

- To return to the home screen, simply press the hang up button  .

#### 4. FIRST STEPS BEFORE SWITCHING ON

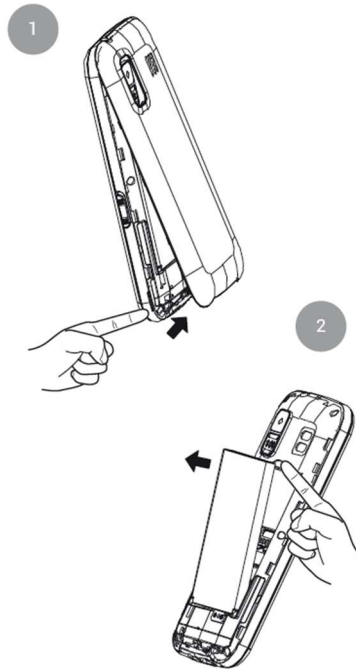

Lift the battery cover by the tab on the bottom of the phone and remove the battery by lifting it out of the recess at the top of the battery compartment.

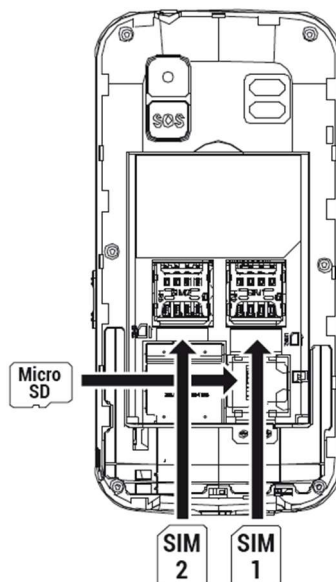

Insert the SIM card(s) (MicroSIM format) in the indicated position, paying attention to the gold contacts on the phone and card(s).

If necessary, insert the Micro SD memory card in the specified location.

Insert the battery by matching the gold contacts on the phone and the battery.

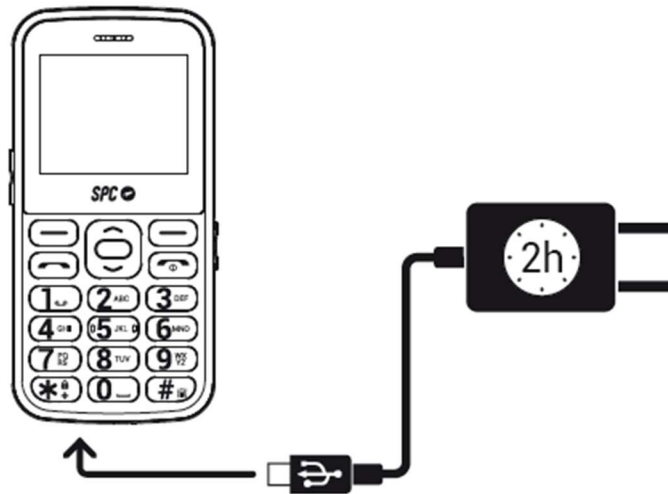

To charge the phone, plug the power adapter into the USB port on the bottom of the phone. The port is USB Type-C, which means it does not have a specific orientation. However, you should not force the connection if it is not instantaneous.



You can also connect the power supply to the charging station. As already described, you should not force the connection if it does not happen immediately.

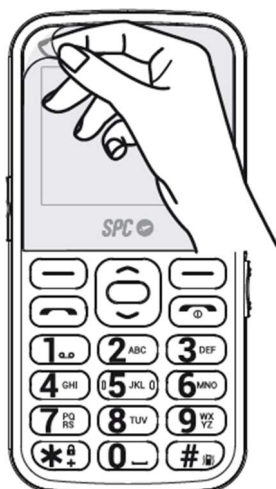

Remember to remove the screen protector before using the device.

## 5. SWITCH ON TELEPHONE



Press and hold the power button for a few seconds to turn on the phone. Enter the PIN displayed on your SIM card. If two SIM cards are inserted, the phone will first ask for the PIN of SIM 1 and then SIM 2.

Press and hold this button to turn off the phone.

*NOTE: The personal identification number (PIN) protects the SIM card from unauthorized use. You can use the PIN unlock key (PUK number) to unlock a locked PIN. The PIN and PUK are supplied with the SIM card. For further details, please contact your mobile network provider*

## 6. UNLOCK OR TURN ON THE PHONE SCREEN

The phone is set by default to turn off the screen if it is not used for a few seconds. The keypad is not locked. So, if you touch any key, the screen will turn back on without you having to enter an unlock password.

You have the option to lock the keyboard if needed by pressing the hang up key or even the menu key and then the \* (asterisk) key on the bottom left with the padlock design. To unlock it, you need to follow the exact same steps: Menu ...>\* (asterisk).

Also, if you want to configure the phone to lock the keypad when it has not been used for a while, you can do that from here:



- Menu>Settings>Phone settings>Display>Automatic key lock and select the time you want it to be locked.

## 7. CALL

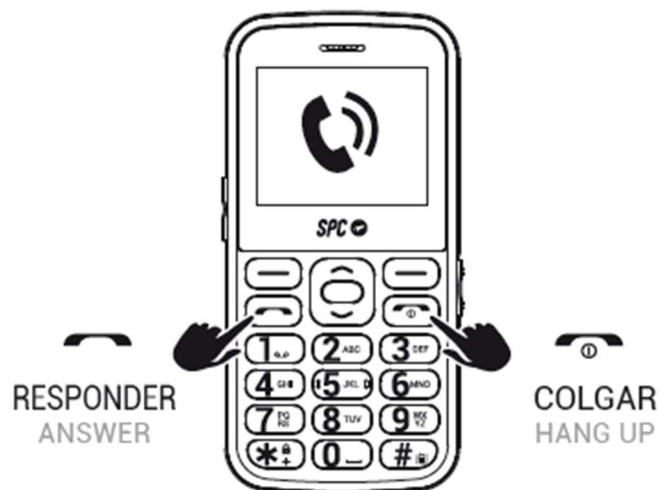

If you use two SIM cards, the phone will ask you to confirm the SIM card you want to use before making calls.

During a call, you can make and receive other calls from/to the same number, but you cannot make or receive calls from/to the other SIM card.





1. Dial the number you want to call.
2. Press "Delete" to delete the incorrectly entered digits.
3. Press  and select the SIM card you want to use to make the call. Press .
4. When you make a call and the number is stored in the address book, the contact's name is displayed on the screen.
5. Press  to end the call.



## Call a contact from the address book

1. Press "Address Book" on the home screen with the right soft key. The screen displays the list of contacts in alphabetical order.
2. Use the up/down keys to scroll through the list to the desired contact.
3. Press the call button  to call the selected contact.
4. Press the hang-up button  to end the call.

## Call from history

1. With the phone switched on, press the  key to call up the list of sent calls. You can also call up the call list from the main menu.
2. Use the navigation keys to scroll through the list, select an entry and press  to call.

## Accept / reject call

When you receive a call, the number or name is displayed on the screen. Press the  key to accept the call or  to reject it.

## During a call

Press "Handsfree" during the call to activate the handsfree mode.

Press "Options" during the call to access the various options:

- Second call
- End call
- Address book
- Call history
- Messages
- Sound recorder
- Mute

## 8. SPEED DIAL

The phone has eight indirect storage options.

Indirect memories or speed dial numbers are numbers that are activated by pressing and holding one of the digits 2 to 9.

To set up these numbers, you must have a SIM card installed and:

- Go to Menu -> Address Book -> Options -> Address Book Settings -> Speed Dial
- Activate the function (status: On),
- and set the number. The number 1 is reserved for the answering machine and is set by pressing and holding 1.

## **9. RINGTONES, SOUNDS AND VOLUME**

This setting can be found in the "Profiles" menu. Here you can select and configure the type of ringtone for calls, volume, message tone, etc. The selected profile is General by default.

Use the arrow keys to switch between the available profiles (General, Silent, Meeting and Outdoor) and confirm your selection with the center key.

Select a profile and click Options to enable, customize, or reset it.

You can customize a profile according to your taste and needs and set the following parameters:

- Select the notification type and choose between sound only, vibration only, vibration and sound, or vibration and then sound.
- Type of ringing (repetition or only one beep).
- Select the ringtone for incoming calls on SIM 1 (from a choice of 7 ringtones or select a melody stored in the phone files).
- Select the ringtone for incoming calls on SIM 2 (from a choice of 7 ringtones or select a melody stored in the phone files).
- Select the call volume.
- Select the ringtone for messages received on SIM 1 (from a choice of 6 ringtones or select a melody stored in the phone files).
- Select the ringtone for messages received on SIM 2 (from a choice of 6 ringtones or select a melody stored in the phone files).
- Select the volume of the received messages (6 levels).
- Choose the type of key sound between a click, a tone or mute.
- Select the volume of the key tone (7 levels).
- Activate or deactivate the system alarm (e.g. low battery...).

## **10. ADDRESS BOOK**

### **a. View address book**

1. When the phone is in standby mode, press the "address book" key.
2. Or access the address book from the main menu.

Use the navigation keys "up/down" to scroll through the list and display all contacts.

### b. Quick search:

With the contact list displayed (previous step View address book), enter the first letters of the contact you are looking for. The contacts containing these letters will be displayed on the screen.

### c. Options for contact:

Select a contact and press Options to display the available options:

- View,
- Send SMS,
- Choose
- Edit,
- Delete,
- Copy,
- Add to blacklist for calls or messages,
- Mark several,
- Caller Group,
- Address book settings.

### d. Add a contact

1. When you enter the address book, select the "Add new contact" option at the top and press OK.
2. Select the memory where you want to save the contact (on SIM1, SIM2 or in the phone).
3. Enter the contact information (name, number).
4. After editing, press Options > Save to save the contact.

## 11. Messages

### a. Receive new message

When you receive a new text message, the phone beeps and displays a notification on the screen. Also, the  icon is displayed on the screen.

To open the message:

1. Select "View" when the notification appears on the screen or go to the "Messages --> Inbox" menu. New messages are marked with a closed envelope icon.

2. Press OK to open and read the message.  .

*NOTE: The new message icon  will remain on the screen as long as there are unread messages.*

Options for messages:

When you open a message, you can:

- Reply: Reply to the sender with an SMS message.
- Call the sender: Make a phone call to the sender.
- Forward: Forward the message to another contact.
- Delete: Delete the message.
- Advanced: Advanced options for SMS messages: Use the number or USSD, copy or move the message to the SIM card.

## b. Write a message

Go to Menu --> Messages --> Write message.

Under Options>Input Method you can select the following

- ABC (all in capital letters),
- abc (all lower case),
- Abc (the first capital letter and the rest lowercase),
- EN (English, all caps),
- en (english, all lower case),
- En (English, first capital letter, all lowercase),
- The same is true for other languages: French, Spanish, Italian and Portuguese,
- Numeric,
- Insert symbols

You can also select the language and switch between upper- and lower-case letters and numbers within Write Message by pressing the # key once. The icon in the upper left corner indicates the mode in use.

In addition, when writing a message, pressing the \* (asterisk) key once will give you direct access to the symbols you can insert.

## 12. SOS BUTTON

The SOS button is a physical button located on the back of the phone. If you are in an emergency situation, simply press this button for a few seconds (once configured, see "Setting up SOS numbers") and the phone will automatically make a call and send an emergency SMS to up to 5 numbers.

To use this function, you must configure the SOS emergency numbers.

## Configuration of the SOS button:

Via "Menu"-->"SOS":

- Set the status of the function: "On" or "Off".
- Set the SOS message. Write the help message to be sent to the SOS numbers. By default, the message sent is "I need help!"
- Set the emergency numbers to "SOS number" (1 to 5).

## Use of the SOS function:

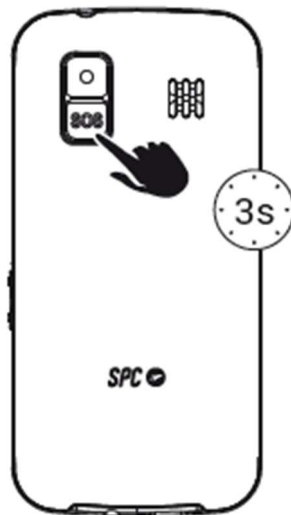

If you are in an emergency situation and press the SOS button, the phone will:

- Emit a warning tone (horn) and start the call cycle.
- Activate the hands-free function.
- Call the SOS numbers one by one and also send the SOS message by SMS.
- If there is no answer, it jumps to the next number until one of them answers. This cycle is repeated 3 times.

*\*Note\** If a number on the list has an answering machine, the cycle will end.

*SMS can increase your monthly bill depending on the type of contract you have with your operator.*

## 13. SMART HELP

## What is Smart Help?

Smart Help is a set of intelligent help features that allow FORTUNE 2 users to use their device worry-free and help their family members and friends take care of them even when they are far away. You can configure them from the Settings > Smart Help menu.

Smart Help allows you to:

- Configure FORTUNE 2 remotely from another phone,
- Send notifications from this phone to another phone during low usage or complete inactivity,
- and activate the FORTUNE 2 ringer for unanswered calls to the maximum volume....

The following section describes each of these functions.

### Remote configuration

This feature allows you to give permission to up to 5 numbers to remotely control your phone via SMS from another phone.

For this you need to:

- Enable the remote configuration feature, under Settings > Smart Help > Remote Configuration > Status > Enabled,
- Add to the list of \*numbers the contacts you want to give permission to configure your phone remotely (maximum 5) under "Settings > Smart Help > Remote configuration > Allowed numbers".
- After adding the number, you need to save the settings by pressing Options>Save.

*\*You must specify the area code (+34 for Spanish mobile numbers), for example +34611222333.*

These are the 2 FORTUNE 2 functions that can be configured from another phone via SMS.

#### 1. **ENABLE AND CONFIGURE SOS FUNCTION (if the phone has this function).**

Send an SMS to your phone from one of the approved numbers with the following codes:

- To activate/deactivate the SOS function:

ACTION	SMS CODE
Activate the SOS function	*SOS#1#
Deactivate the SOS function	*SOS#0#

- To set phone numbers in the SOS list:

ACTION	SMS CODE
Configure the number 611 111 111 as the 1st in the SOS list	*SOS#2#1#611111111
Configure the number 622 222 222 as the 2nd in the SOS list	*SOS#2#1#622222222

Configure the number 633 333 333 as the 3rd in the SOS list \*SOS#2#1#633333333  
 Configure the number 644 444 444 as the 4th in the SOS list \*SOS#2#1#644444444  
 Configure the number 655 555 555 as the 5th in the SOS list \*SOS#2#1#655555555

- To delete numbers from the SOS list:

ACTION	SMS CODE
Remove number 1 from SOS list	*SOS#3#1#
Remove number 2 from SOS list	*SOS#3#2#
Remove number 3 from SOS list	*SOS#3#3#
Remove number 4 from SOS list	*SOS#3#4#
Remove number 5 from SOS list	*SOS#3#5#

## 2. ADD CONTACTS TO ADDRESS BOOK OR QUICK MEMORY

By sending an SMS to FORTUNE 2 from one of the allowed numbers with the following codes:

- To add a contact to the address book: ("CCC" IS THE NAME OF THE CONTACT).

ACTION	SMS CODE
Add contact 611 111 111 to the address book	*PB#2#CCC*611111111

## 3. SET THE VOLUME OF THE RINGTONE, EARPHONE AND HANDSFREE TO MAXIMUM

Send an SMS to FORTUNE 2 from one of the numbers with permission with the following codes:

ACTION	SMS CODE
Increase volume	*VOL#MAX

## Smart ringtone

With this feature, your phone will automatically increase the volume of the ringtone when it detects that the same person is trying to call you and you have not answered the call.

The ring volume of your phone will be set to maximum if the same phone number repeats the call within 3 minutes. After the call is answered, the volume of your phone returns to the previously set volume.

You can enable or disable it from here:

- Settings > Smart Help > Smart ringtone.

## Smart notifications

This feature allows you to define a set of helpers that will receive SMS notifications when FORTUNE 2 detects an unusual lack of activity:

- Settings > Smart Help > Smart Notifications > Helpers.

A warning SMS is sent to the set numbers when:

- The battery level of your phone is below 15%.
- There is 1 unanswered missed call.
- FORTUNE 2 has been inactive for the last 24 hours, i.e. when it detects that you have not pressed any buttons, opened or closed the lid, or charged the device.

You can enable or disable any of these warnings at

- Settings > Smart Help > Smart Notifications.

## **14. MULTIMEDIA**

### **a. Camera**

(A micro SD memory card is required).

Activate the camera by going to "Menu" --> "Multimedia" --> "Camera".

OK button - Press this button to take the photo.

Under "Options" --> "Camera settings" you can adjust the camera parameters.

Once the photo is taken, you can select Send via Bluetooth or Delete the photo under Options.

Under "Options" --> "Photos" you can also access the photos you have taken. Once you are in the photo, you can access a larger number of options under "Options":

- look at the picture,
- send it via Bluetooth,
- use it as a wallpaper,
- rename,
- Delete or
- View image details.

If you return to the previous menu, you will find the following functions, among others, under "Options":

- Switch to video camera
- Camera settings
  - LED activation
  - Antiflickering
  - Automatic scene mode
  - Timer
- Image configuration
  - Image size
  - Image quality
- Storage location (to choose where you want to store the photos)

- Restore default settings

## **b. Image viewer**

Here you will find the pictures you have taken with your phone's camera. With the "Options" menu you can do the same as in point 13 a.:

- View
- Send
- Use as
- Rename
- Delete
- Image information

## **c. Video player (a micro SD memory card is required)**

With the camera activated, go to "Options" --> "Switch to recorder".

OK button (middle button) - press this button to start/stop the video.

Other functions that you can find under "Options" are:

- Video camera settings to adjust the anti-flicker function
- Video settings to adjust the video quality
- Storage (to choose where you want to store the videos)

To switch back to camera mode, follow the same steps and select "Switch to Camera".

## **c. Music player**

Call up the audio player via "Menu" --> "Multimedia" --> "Audio player". Play the music in the phone memory/SD card.

## **e. Sound recording**

It is located under the "Multimedia" menu. You can record calls and start, pause and end the recording with the function keys. Under "Options" you can access the recordings and set the storage.

## **f. FM radio**

(Headphones are not required for channel reception).

Access the FM radio via "Menu" --> "Multimedia" --> "FM radio".

OK button - Press this button to play/stop the radio.

Number keys 4 and 6 - press these keys to change the radio station.

Navigation buttons up/down - to increase/decrease the tuner frequency.

Side buttons or \* and # - press these buttons to decrease/increase the volume.

You can access the following via the "Options" menu

- view the list of found stations,
- manual station search
- automatic search,
- Access the FM Radio settings
- record the broadcast (with microSD card),
- Access the list of files
- exit the FM Radio App.

## **15. SETTINGS**

The following options are available in the Settings menu.

### **a. Phone configuration**

Here you can set the following:

- Date and time,
- Language,
- Text input method (see point 11 b.),
- Screen (background, lock, display date and time), and
- dedicated keys (for one function when pressing the middle key up and another when pressing the middle key down)
- Flight mode
- Other settings - LCD display brightness.

### **c. Security settings**

Configure and change security and privacy settings and codes by accessing the following:

- Telephone security to
  - o Manage phone lock
  - o Change password
- Lock keyboard with end key

### **d. Dual SIM configuration**

For dual SIM operation mode configuration, you can choose between:

- Open Dual SIM.
- Open SIM1 only.
- Open SIM2 only, open SIM1 only.

### **e. Smart Help**

See item 13 SMART HELP.

## f. Restore configuration

Allows you to reset the phone settings to factory defaults. You must enter the phone settings password, which is 0000 by default.

## 16. BATTERY AND CHARGING PROCESS

You have two ways to charge your phone:



1. - Plug the adapter that you will find in the package into any power outlet in your house. Connect the other end of the power adapter to the phone's port to charge the battery.

2. - Connect the adapter cable to the back of the charging station and place the phone in the station.

In both cases, the battery icon during charging indicates that charging is in progress when the screen is activated.

### Important note about the charging process

For good maintenance and to extend the life of the battery, do not store the battery for a long period of time with a full charge or with a very low charge, but rather with a medium charge.

It is recommended not to leave the phone charging for a long time (vacation, etc.). It is better if the battery is fully discharged from time to time.

If the phone will not be used for a long time, remove the battery at a medium charge.

If the battery has not been used for a long period of time or is exhausted, the phone's screen may not work when the battery is recharged. Once the battery has been charged for a while, you can turn on the phone to use it.

## Low battery warning

When the battery is almost empty, the battery indicator is empty and the phone emits a warning tone and displays a message on the screen. You need to connect the AC adapter to charge the battery.

When the phone battery is empty, the phone turns off and you cannot make or receive calls.

## 17. OTHER FUNCTIONS / TOOL MENU

### a. SKT

Operator's toolkit and features (for operators who support it).

### b. Bluetooth

Via this option you can:

- Switch Bluetooth on or off
- Manage your visibility on other devices
- Search for other devices and pair them with your device
- Search for devices that were previously paired with your FORTUNE 2
- Change the name of your device
- Other advanced options

### c. Calculator

Calculator located in the "Extras" menu. Use the numeric keys and the up/down/left/right navigation keys.

### d. Calendar

Calendar function can be found in the "Extras" menu. You can access a specific date via "Options".

### e. Alarm

It is located in the "Extras" menu. Using this option you can configure up to 5 different alarms. Select one of the alarms (by default they are disabled) and press "Edit" to configure them.

You can set the time, ringtone and repeat mode or frequency. After configuration press "Options" --> "Save" to confirm your changes.

## f. World clock

This function is located in the "Extras" menu. Use the navigation keys to change the time zone. You can also enable/disable daylight saving time.

## 18. FLASHLIGHT

The phone has a flashlight that you can turn on and off by sliding the switch on the right side of the phone up or down, without the phone having to be on.

## 19. TECHNICAL DATA

### SCREEN.

Resolution QVGA 220x176 pixels. Screen size: 2.2". GSM signal indicator. Battery status.

ADDRESS BOOK 500 CONTACTS.

### CONNECTION.

Dual SIM. GSM 850/900/1800/1900. Bluetooth. FM radio. Micro SD card slot.

### BATTERY.

1200mAh lithium battery.

### DIMENSIONS AND WEIGHT.

Dimensions: 124x60x13mm. Weight: 88g

THE BOX CONTAINS. Telephone. Charging station. Power supply. Battery. User manual.

## 20. FREQUENTLY ASKED QUESTIONS

### The phone does not start

- The phone is turned on by pressing and holding the  button.
- Make sure that the battery is properly inserted in the battery compartment.

- The battery may not be charging. Connect the charger to the phone and check if a battery charging icon is displayed on the screen. Wait a few minutes for the battery to charge sufficiently before trying again.

### **The phone is not charging properly.**

- For proper charging, connect the AC adapter to the phone and follow the instructions in this manual, section 16.
- The phone can be charged both in the off state and in the on state. When charging in the off state, at the beginning or by briefly pressing any key, a battery charging icon appears on the screen. When on, the battery icon in the upper right corner moves its bars to indicate that the battery is charging.
- If it still does not charge, the problem could be with the power supply. The phone's charging port is a standard USB Type-C. It is recommended to use the included power adapter. However, you can also use another USB Type-C charger as long as it is reliable.

### **The phone cannot make or receive calls.**

- To make calls with the phone, you need a SIM card from a mobile network provider. Follow the instructions in the manual to insert the SIM card correctly. Turn on the phone after inserting it. Normally, you will be asked for the PIN code of the card, and after you enter it, the phone will boot up. It should display the operator's name and the mobile coverage icon in the upper left corner with bars indicating the level of coverage.
- If you cannot make or receive calls, the SIM card may be inserted incorrectly and is not recognized. Make sure that the SIM card is inserted into the slot with the notch in the indicated position and with the metal contacts facing down. Note that the format must be Micro-SIM. If your card is smaller (Nano-SIM), you must add the appropriate adapter. Your operator can provide you with this adapter.
- This phone has two SIM slots. Check the card in the other slot. It is possible that the contacts in one of the slots are dirty or bent.
- Make sure you have network reception from your cellular service provider. You may not have reception in your area, or your cellular service provider may be temporarily unable to provide reception due to a technical problem. At the top left of the screen are cellular coverage icons with a series of bars indicating signal strength. If there is no reception, a cross is displayed on the corresponding icon.

### **The phone does not ring or rings very weakly for incoming calls.**

- Check if you have configured the ringtone setting of your phone correctly. To do this, follow the instructions on profiles in this manual (point 9).
- You may have accidentally pressed the # key. Pressing the # key continuously will switch the phone to Meeting mode and mute the phone so as not to disturb. Press the # key again continuously to return to the General profile.