



Questo manuale d'istruzione è fornito da trovaprezzi.it. Scopri tutte le offerte per [TechniSat TechniPlayer LP 200](#) o cerca il tuo prodotto tra le [migliori offerte di Personal Audio e Hi-Fi](#)

Instruction Manual



TECHNIPLAYER LP 200

TechniSat

Preface

This operating manual outlines

- proper and
- safe

use of your **record player**, referred to below as "record player" or "unit".

Take note of the

instructions for using the USB terminal on p. 17.

Target group of this operating manual

This operating manual is intended for everyone who

- sets up,
- operates,
- cleans
- or disposes of the unit.

All brand and product names are trademarks or registered trademarks of their respective manufacturer.

Layout features of this operating manual

Various items in the operating manual are provided with set layout features. This ensures you can easily determine whether you are dealing with

normal text,

- a list or
- steps to be carried out.



Install the Audacity® software on a PC or Mac **before connecting and operating** the unit.

An alternative program, for example, is the "Free MP3 Sound Recorder".

You can download it on the Internet at www.nbxsoft.com/sound-recorder.php

Contents

Safety and setting up the record player	4
Safety	4
Setup	6
Description of the appliance	8
Included in delivery	8
Special features	8
The controls	9
How to prepare the record player for operation	11
Belt and turntable.....	11
Turntable mat.....	11
Spindle adapter.....	11
Tone arm	11
Fitting the tone arm head.....	12
Fitting the counterweight.....	12
Balancing the tone arm.....	12
Setting the tracking force	13
Anti-skating setting	13
Connecting the record player	14
Connection to the amplifier	15
Connection to the computer.....	15
Mains connection	15
How to set the PHONO/LINE switch.....	15
Removing/attaching the stylus protection cap	15

Playing a record	16
Automatic start	16
Manual start	16
Stop button.....	16
Before establishing the USB connection	17
System requirements	17
How to digitise your music	18
Installing the software	18
Connecting the record player.....	18
Setting up the software	18
Recording and saving music.....	19
Cleaning the record player	20
Electric shock.....	20
Cleaning the stylus and the record	20
Replacing the stylus.....	20
Troubleshooting	21
Technical specifications	22
Disposal instructions	23

Safety and setting up the record player

Please read through all of the safety instructions carefully and keep them for questions that may arise later. Always observe all warnings and instructions in this operating manual and on the rear of the unit.

Safety

- The unit should only be connected to a mains voltage supply of 230 V~, 50 Hz. Never try to operate the unit with a different voltage.
 - The mains plug should only be connected after installation has been completed according to the instructions.
 - If the mains plug of the unit is defective or if the unit shows other damage, it must not be operated.
 - When unplugging the mains cable from the socket pull on the mains plug, not on the cable.
 - In order to avoid fire hazards and the risk of electric shock do not expose the unit to rain or moisture.
 - Do not touch the mains plug with wet hands—risk of electric shock!
 - In the event of malfunctions or smoke and odour coming from the housing remove the mains plug from the socket immediately!
- Before a thunderstorm breaks, pull the mains plug.
 - If the unit is not going to be used for a prolonged period, e.g. in the event of a long trip, remove the mains plug from the socket.
 - Remove the mains plug from the socket if you do not intend to use the unit for a prolonged period. Only pull on the plug itself.
 - Lay the mains cable in such a way that no one can trip over it. Do not place any heavy objects on the mains cable.
 - Make sure the power cable or plug is always easily accessible so that the unit can be disconnected quickly from the power supply!
 - This socket should be as close to the unit as possible.
 - Fully insert the mains plug into the socket.
 - Use a suitable, easily accessible mains connection and avoid using multiple sockets!
 - Prevent the unit from coming into contact with water or moisture.
 - Do not operate the unit in the vicinity of bathtubs, swimming pools or spraying water.
 - Do not place any containers which contain a liquid on the unit, such as a flower vase. These could fall over and the spilled liquid could lead to severe damage or the risk of electric shock.
 - The appliance should not be sited in rooms with high levels of humidity, e.g. kitchens or saunas, as the

formation of condensation on the appliance may damage it.

- The appliance is intended for use in a dry environment and a moderate climate and must not be exposed to dripping or splashing water.
- If any foreign material or liquid enters the unit, remove the plug from the socket immediately. Get the unit checked by a specialist before starting to use it again. Otherwise you are at risk of receiving an electric shock!
- Do not open the housing. Otherwise you are at risk of receiving an electric shock!
- Never attempt to repair a defective unit yourself. Always contact one of our customer service locations.
- Never open the unit under any circumstances - this should only be undertaken by a specialist.
- Foreign material, e.g. needles, coins, etc., should not be allowed to enter the unit.
- No open flames, such as burning candles, are permitted to sit on the unit.
- Never let children use this unit unattended.
- Always leave maintenance tasks to a qualified technician. Otherwise you put yourself and others in danger.
- When the appliance is on standby it remains connected to the mains power supply. Remove the mains plug from the socket if you do not intend to use the unit for a

prolonged period. When unplugging the appliance from the mains, only pull on the plug, not on the power cord.



Do not listen to music or radio broadcasts at very high volumes. Doing so can cause lasting damage to your hearing.

- This appliance is not intended for use by persons (including children) with limited physical, sensory or mental capabilities or who lack the necessary experience and/or knowledge, unless they are supervised by a person responsible for their safety or have been instructed by such a person on how to use the appliance.
- Children must be supervised in order to ensure that they do not play with the appliance.
- Making modifications to the appliance is prohibited.
- Do not continue to use the appliance and/or accessories if they are damaged.
- Use only appropriate cleaning agents (antistatic) to clean the unit and the records. These are available in an accessories store.

Setup

- The record player must be set up only on a sturdy horizontal, vibration-free surface.
 - Do not set up the unit in the vicinity of heat sources, such as radiators. Avoid direct sunlight and excessively dusty places.
 - You should only operate the unit when it is positioned horizontally.
 - Do not place any heavy objects on the unit.
 - Not to be used in the open air.
 - Please note that the appliance feet may, under certain circumstances, leave coloured marks on certain furniture surfaces. Place something between the item of furniture and the appliance to protect the surface.
 - Keep the unit away from devices that produce strong magnet fields.
 - If you bring the record player from a cold into a warm environment, moisture may form on the inside of the unit. In this case, wait about an hour before you operate it.
 - Lay the mains cable in such a way that no one can trip over it.
 - Fully insert the mains plug into the socket.
 - Make sure the power cord or plug is always easily accessible so that the unit can be disconnected quickly from the power supply.
 - This socket should be as close to the unit as possible.
 - Avoid using multi-socket extensions.
- Do not touch the mains plug with wet hands—risk of electric shock!
 - In the event of malfunctions or smoke and odour coming from the housing remove the mains plug from the socket immediately!
 - Before a thunderstorm breaks, pull the mains plug.
 - If the unit is not going to be used for a prolonged period, e.g. in the event of a long trip, remove the mains plug from the socket.
 - Do not connect any other type of device to the USB interface. The USB interface is only suitable for direct connection to a PC.

Do not remove any covers.



Intended use

The appliance is intended for playing and digitising gramophone records. The appliance is designed for use in a private home and is not suitable for commercial use.

Use of any other kind is classed as other than intended and may result in damage to property or even personal injury.

The manufacturer accepts no liability whatsoever for loss or damage arising from use of the appliance in a manner other than intended.

Before using the appliance for the first time, please carefully read through the safety instructions and installation instructions. Only by doing so will you be able to use all functions safely and reliably. Keep the installation instructions in a safe place and pass them on to any subsequent owner.

Description of the appliance

Included in delivery

- Remove the unit and all accessory parts from the packaging.

Note: the loose parts are in the sides of the polystyrene packing.

Keep the box and the packing so as to be able to pack the appliance securely if it needs to be transported at any time in the future.

Please ensure that all of the accessory parts in the following list are present:

- The record player
- Turntable with drive belt fitted
- Cartridge pick-up system with stylus
- Counterweight
- Turntable mat
- Lid with 2 hinges
- Spindle adapter (for 7" EPs)
- USB cable
- This operating manual.

Special features

- With this appliance you can: play 33 rpm and 45 rpm vinyl records.
- It offers fully automatic control functions.
- The tone arm is automatically set down and returned at the end of the record.
- Using the USB terminal and the Audacity software, you can transfer your records to your computer and digitalise them.
- The record player has an integrated equaliser/preamplifier and can be connected to a phono input as well as an audio input (AUX-In).



The controls

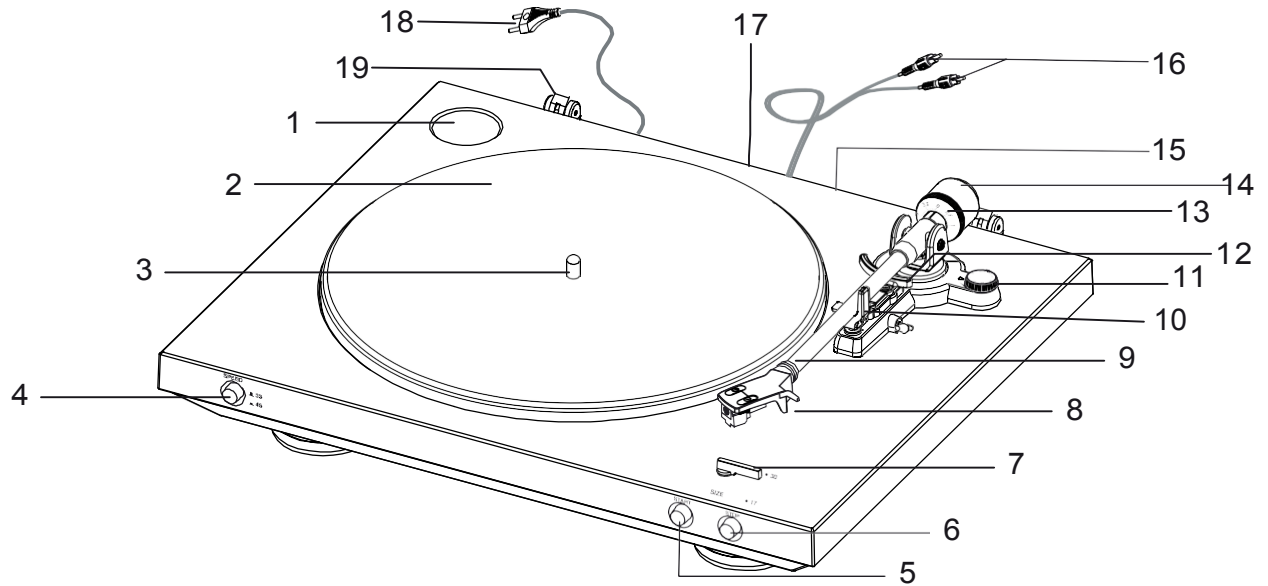

Description of the appliance

1	Storage recess for spindle adapter (for 7" EPs)
2	Turntable with turntable mat
3	Turntable spindle
4	Speed selector (33/45)
5	Start button (START)
6	Stop button (STOP)
7	Record size selector lever (SIZE 30/17)
8	Cartridge holder
9	Tone arm
10	Tone arm rest
11	Anti-skating adjuster
12	Tone arm lift lever
13	Tracking force adjuster (scale faces forwards)

14	Counterweight
15	PHONO/LINE selector
16	Phono lead (with red and white jacks); red = right channel, white = left channel
17	USB connection, max. lead length = 3 m
18	Mains cable
19	Brackets for lid hinges

How to prepare the record player for operation

Belt and turntable

The record player is delivered with the drive belt already fitted around the turntable flange. The belt is provided with a red tape so that it can be pulled over the drive motor pulley.

- Place the turntable on the turntable spindle. Rotate the turntable until the cut-out is positioned over the motor pulley (at about the 8 o'clock position). See illustration below.
- Using the red tape, pull the drive belt over the motor drive pulley and position it in the centre of the pulley. Then remove the red tape.

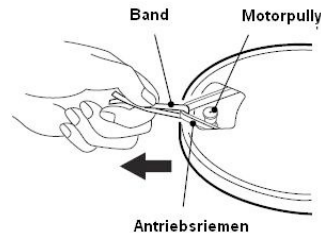

Turntable mat

Now place the turntable mat on the turntable.

Spindle adapter

The spindle adapter is required, for example, for singles without their own plastic spindle adapter. When the spindle adapter is not in use, you can store it in the designated area.

Tone arm

The tone arm **9** is secured for transport using a clip. Remove this clip before operating the unit for the first time. To transport the unit later, secure the tone arm again using this clip to prevent damage from vibrations.

Fitting the tone arm head

- Fit the tone arm head 1 on the tone arm tube 3 as shown.

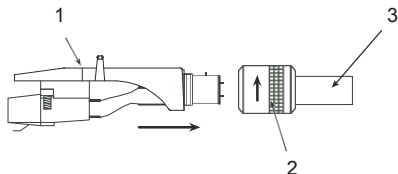

- Secure the tone arm head to the tone arm by turning the locking ring 2 clockwise while holding the tone arm head horizontal.

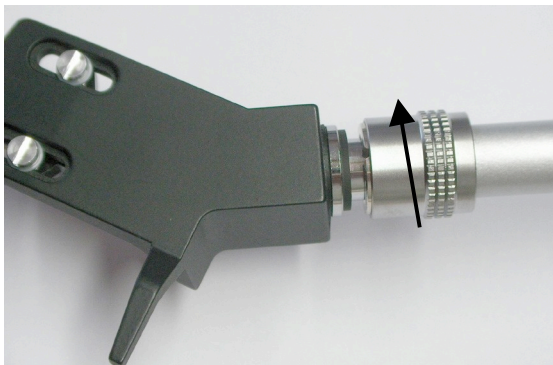

Fitting the counterweight

The counterweight 2 is screwed onto the tone arm as illustrated.

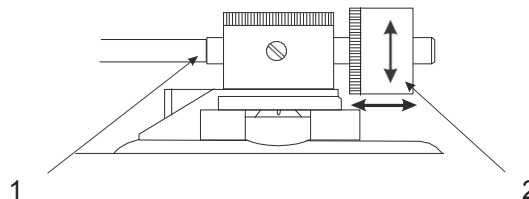

Balancing the tone arm

- If the pick-up cartridge is fitted with a removable stylus cover, remove it. Take care not to touch the stylus tip with your fingers.
- Lift the tone arm off the tone arm rest.
- Turn the counterweight 2 clockwise or anti-clockwise until the tone arm balances more or less horizontally of its own accord.

When adjusting the horizontal balance "0" setting take care that the pick-up stylus does not come into contact with the turntable mat or any other objects.

Setting the tracking force

- Hold the counterweight firmly with one hand and turn the counterweight adjuster scale until the "0" mark is at the 12 o'clock position (vertical).
- Now turn the counterweight anti-clockwise to set the correct tracking weight.

The tracking weight can be read off directly from the adjuster scale.

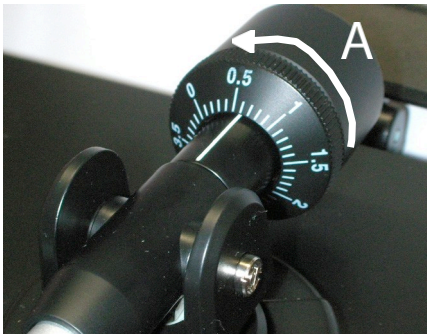

Note:

The recommended tracking weight for the cartridge pick-up system supplied is 3.0 - 3.5 grammes. If in doubt follow the recommendation of the pick-up cartridge manufacturer.

Anti-skating setting

The skating force exerts a pull on the tone arm towards the centre of the disc that increases the force on the inner edge of the record groove. To compensate for the skating force and the negative effect it has on the sound pick-up from stereo records in particular, the record player has an anti-skating mechanism.

- Set the anti-skating adjuster 11 to the **same** figure as the tracking force.

Connecting the record player

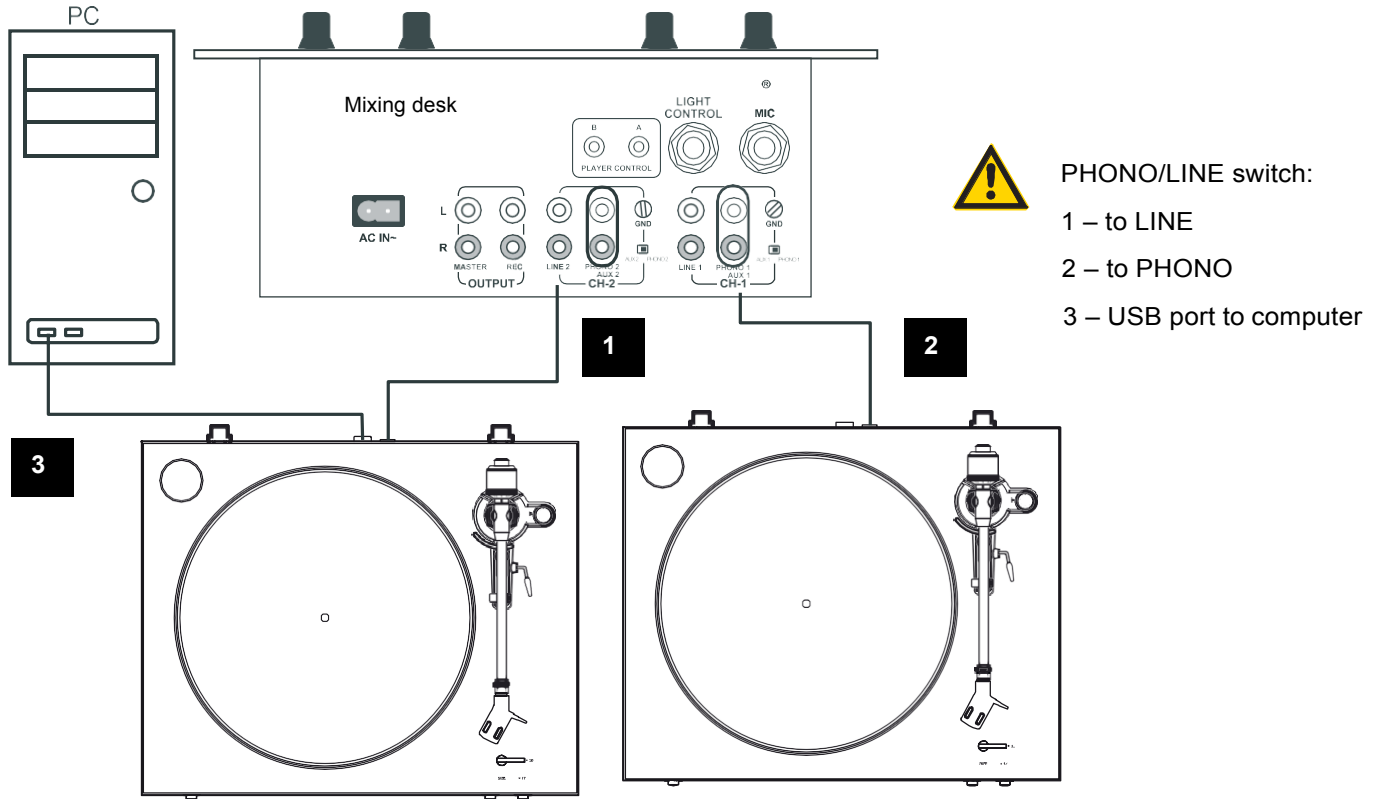

Connection to the amplifier

- Connect the phono lead 16 to the LINE/AUX or phono sockets on the amplifier.

Note:

When doing so, make sure the left and right channels are connected the right way round (red = right channel, white = left channel)

Connection to the computer

- Connect the USB terminal 17 with a free USB port on your computer. Follow the instructions on p. 17.

Mains connection

- Plug the mains plug 18 into a power outlet socket

How to set the PHONO/LINE switch

- Move the PHONO/LINE switch **15** to PHONO if the record player is connected to the PHONO jacks.
- Move the PHONO/LINE switch **15** to LINE if the record player is connected to the LINE jacks.

Removing/attaching the stylus protection cap

- Before playing a record, you must remove the stylus protection cap from the pick-up cartridge. To do so, pull off the cap forwards.

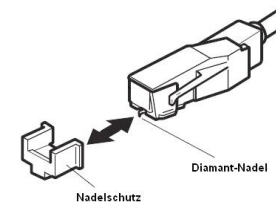

- It is recommended that you put the stylus cap back on after playing a record to protect the stylus.

Playing a record

Automatic start

- Put on a record. If necessary, fit the spindle adapter **1** to play singles. Remove the stylus protector if necessary.
- Use the selector lever **7** to set the record size to 30 cm (12 inch) or 17 cm (7 inch) as appropriate.
- Use the SPEED selector **4** to set the turntable speed to 33 or 45 rpm.
- Press the START **5** button. The turntable begins turning at the set speed. The tone arm automatically sets itself onto the record. Playback begins.

Manual start

- Put on a record. If necessary, fit the spindle adapter **1** to play singles. Remove the stylus protector if necessary.
- Use the selector lever **7** to set the record size to 30 cm (12 inch) or 17 cm (7 inch) as appropriate.
- Use the SPEED selector **4** to set the turntable speed to 33 or 45 rpm.
- Using the tone arm lift lever **12**, raise the tone arm **9** to the UP position.

- Take the tone arm from its support and swivel it over the record's lead-in groove. The turntable begins turning at the set speed. Using the tone arm lift lever **12**, lower the tone arm **9** onto the record.
- The tone arm lift lever **12** can be used to raise the tone arm (lift lever in UP position) at any point – including to briefly interrupt playback. The turntable keeps turning.

Stop button

When the end of the record is reached, the tone arm automatically returns to its support and the unit switches off.

Note:

You can also switch off the record player by pressing the STOP button **6**. The tone arm is automatically returned to the tone arm rest and the appliance switches off.

Alternatively: raise the lift lever **12** to the UP position and move the tone arm back to the tone arm rest.

Before establishing the USB connection

System requirements

Before making the connection, please ensure that the computer system fulfils the following requirements:

- Intel Pentium or AMD Athlon, 1GHz or higher
- (or corresponding Mac computer)
- USB 1.1 or USB 2.0 terminal (2.0 recommended)
- Windows or MAC OSX operating system
- Compatible sound card
- Memory: > 512 MB
- CD or DVD burner for creating audio CDs
- Loudspeaker, mouse
- 10 MB of free hard drive space for the software installation
- Additional free hard drive space for digitalising your music

Note:

- Install the Audacity® software on a PC or Mac **before connecting and operating** the unit.
- The Audacity® software is a free open-source application distributed under the GNU General Public Licence (GPL). Please check their website to see if an update is available. Newer versions or updates are available from <http://www.audacityteam.org/> as needed.
- In principle, you can also use any other PC audio recording software.



Install the Audacity® software on a PC or Mac **before connecting and operating** the appliance. An alternative program, for example, is the "Free MP3 Sound Recorder".

How to digitise your music

Installing the software

- Check the website to see if an update is available (<http://www.audacityteam.org/>) and if there is, install the update.

Note:

In Audacity, click Help > Manual, then the “FAQ” link in the “Navigation” box on the left. The Manual is included with the Windows .exe or Mac OS X .dmg Audacity installers.

Connecting the record player

- Connect the record player's USB terminal 17 with an open USB port on your computer. Maximum lead length 3 metres.

Setting up the software

1. Start the Audacity software.
2. In the menu, select [Edit] and [Preferences]. The software settings open.
3. Click [Devices].
4. As the playback device, select your internal sound card from the [Device] drop-down list.
5. As the recording device, select USB Audio CODEC or "Microsoft Sound Mapper Input" from the [Device] drop-down list.
6. Select channels (2 stereo).
7. Click [Recording]. Tick the checkbox for [Software Playthrough].
8. Click OK. The settings are now saved.

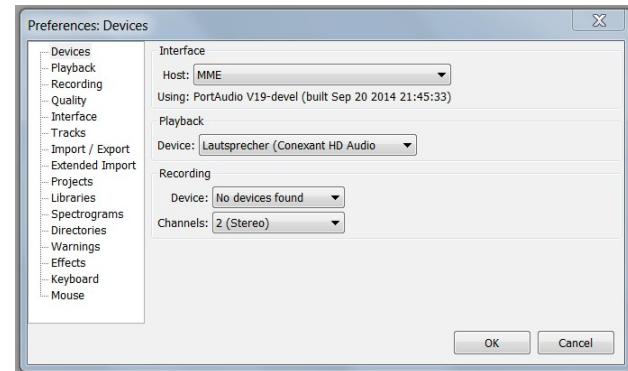

Recording and saving music

1. Start playing the record on the record player.
2. Click the red record button in the software.
3. Click the blue PAUSE button to interrupt the recording temporarily.
4. Click the yellow STOP button to end the recording.
5. Click the green PLAY button to play the completed recording.
6. Click File and select "Export as WAV" to save and export the recording.

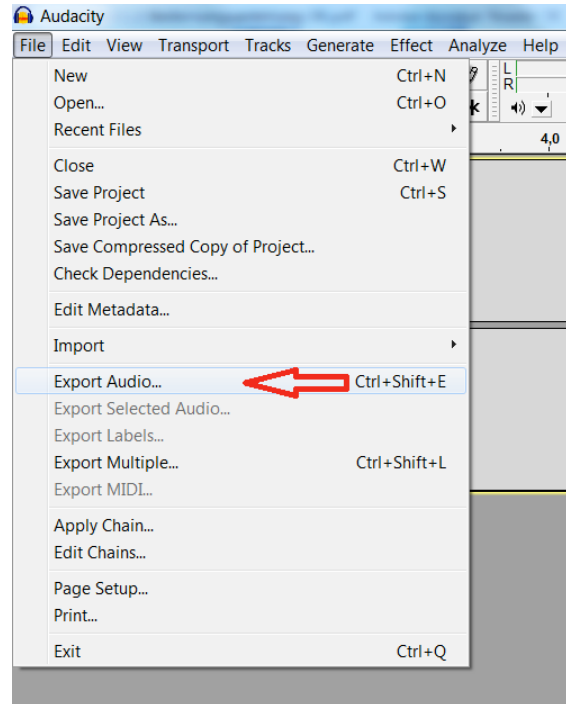

Cleaning the record player



Electric shock

To avoid the danger of an electric shock, you must not clean the unit with a wet cloth or under running water.

CAUTION!

Do not use any scrubbing sponges, cleaning powder or solvents such as alcohol and petrol. To clean the appliance and the records, only use cleaning agents that are specifically designed for the purpose (antistatic). These are available in an accessories store.

- Clean the housing with a soft cloth moistened with water.

Cleaning the stylus and the record

Always clean the stylus and record before playback to prevent premature wear.

- Use a cleaning brush to wipe from back to front over the stylus.
- To clean a record, use a record cloth to wipe lightly and diagonally over the record.

Replacing the stylus

The stylus is naturally exposed to wear by the playback process. Therefore we recommend regular inspection, which for diamond styluses should take place after at least 500 playing hours.

Note:

Worn or damaged (splintered) styluses ruin records. When you need to replace a stylus, use the original type if possible.

- Remove the stylus by pulling diagonally downwards.
- Insert the stylus by doing the reverse of this.

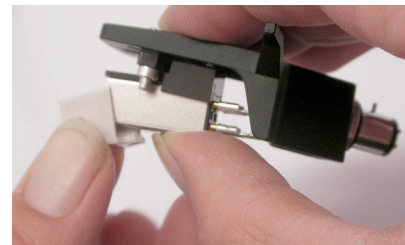
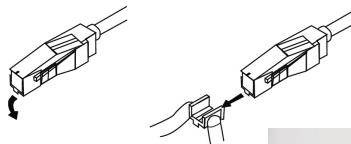

Troubleshooting

If the unit does not function as intended, perform checks using the following tables.

If the malfunction cannot be fixed even after these checks, please contact the manufacturer.

Problems with the unit

Symptom	Possible cause/remedy
The tone arm skips grooves, slides over the record or does not move	The record player is not sitting horizontally. Put the record player on a horizontal base support. The record is dirty or scratched. Clean the record with a record cleaner or play a different record.

Symptom	Possible cause/remedy
Poor tone quality, loud static noise, sound dropouts etc.	The stylus is dirty or worn. Clean the stylus with a brush or replace it. The record is dirty or dusty. Clean the record with a record cleaner.
The speed is incorrect.	Adjust the speed according to the specification on the record. (33 rpm or 45 rpm)
The sound drones.	The drive belt is too loose and must be changed.
The sound is too quiet or loud and distorted.	The record player is not connected to the correct input. (see page 15)
It is not possible to record using the recording software	Restart the PC, check connections Perform a computer system restore (via "Programs", "Accessories", "System Tools").

Technical specifications

Dimensions (width x height x depth):	435 mm x 121.5 mm x 372 mm
Weight:	3.9 kg
Voltage:	230 V AC, 50 Hz
Power consumption:	2 W
Ambient conditions:	+5 °C to +35 °C 45 % to 85 % relative humidity (non-condensing)
Stylus tip:	Diamond stylus
System:	Magnetic system
Wow, flutter	< 0.25% WRMS (JIS WTD), 3 kHz at 33 ^{1/3} rpm
USB port	USB 1.1 for WINDOWS, MAC OSX
Frequency range	20 Hz ... 20 kHz +1/-3 dB
Phono output level	1.5 - 3.6 mV at 1 kHz
Line output level	129 - 313 mV at 1 kHz

We reserve the right to make technical modifications and correct errors.

The dimensions are approximate values.

Directives and standards

Directives and standards

This product conforms to

- the Low-voltage Directive (2014/35/EU),
- the EMC Directive (2014/30/EU) and
- CE Marking Directive.



How to contact the manufacturer

Disposal instructions

Disposing of the packaging

Your new unit was protected on its way to you by the packaging. All materials used are environmentally safe and can be recycled.

Please help and dispose of the packaging in an environmentally responsible manner.

To learn about current disposal methods, contact your dealer or your local disposal facility.



Risk of suffocation!

Keep the packaging and its parts out of the reach of children.

Risk of suffocation from foils and other packing materials.

How to dispose of the unit

Old units are not worthless garbage. Through environmentally friendly disposal, valuable raw materials can be regained. Inquire at your city or municipal administration about possibilities for disposing of the unit properly and in an environmentally sound manner.



This unit is labelled according to 2002/96/EC, the Waste Electrical and Electronic Equipment Directive (WEEE). This product must not be disposed of with normal household waste. Instead it must be deposited at a recycling station for electrical and electronic devices. The symbol on the product, the instructions for use or the packaging indicate this. The materials can be recycled in accordance with their marking. By reusing, recycling or processing old units in another way, you make an important contribution to protecting our environment.



Risk of fatal injury!

Pull out the mains plug of worn-out units. Cut through the mains cable and remove it with the plug.