



Questo manuale d'istruzione è fornito da trovaprezzi.it. Scopri tutte le offerte per [Yamaha DHR10](#) o cerca il tuo prodotto tra le [migliori offerte di Diffusori Audio](#)



Questo manuale d'istruzione è fornito da trovaprezzi.it. Scopri tutte le offerte per [Yamaha DHR10](#) o cerca il tuo prodotto tra le [migliori offerte di Diffusori Audio](#)



DHR Series

POWERED SPEAKER SYSTEM

DHR 15
DHR 12M
DHR 10

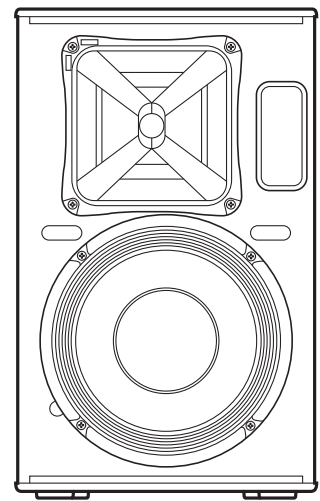
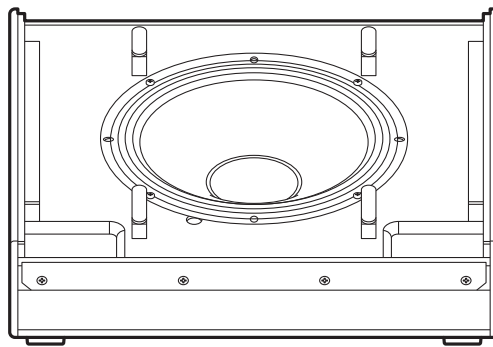
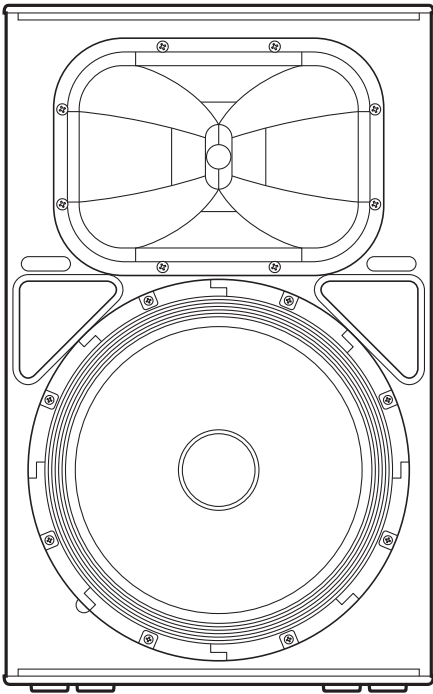

EN Owner's Manual
DE Benutzerhandbuch
FR Mode d'emploi
ES Manual de instrucciones
PT Manual do Proprietário

IT Manuale di istruzioni
RU Руководство пользователя
ZH 使用说明书
KO 사용설명서
JA 取扱説明書

English

Deutsch

Français

Español

Português

Italiano

Русский

中文

한국어

日本語

FCC INFORMATION (U.S.A.)

1. IMPORTANT NOTICE: DO NOT MODIFY THIS UNIT!

This product, when installed as indicated in the instructions contained in this manual, meets FCC requirements. Modifications not expressly approved by Yamaha may void your authority, granted by the FCC, to use the product.

2. IMPORTANT: When connecting this product to accessories and/or another product use only high quality shielded cables. Cable/s supplied with this product **MUST** be used. Follow all installation instructions. Failure to follow instructions could void your FCC authorization to use this product in the USA.

3. NOTE: This product has been tested and found to comply with the requirements listed in FCC Regulations, Part 15 for Class "B" digital devices. Compliance with these requirements provides a reasonable level of assurance that your use of this product in a residential environment will not result in harmful interference with other electronic devices. This equipment generates/uses radio frequencies and, if not installed and used according to the instructions found in the users manual, may cause interference harmful to the operation of other electronic devices. Compliance with FCC regulations does not guarantee that interference will not

occur in all installations. If this product is found to be the source of interference, which can be determined by turning the unit "OFF" and "ON"; please try to eliminate the problem by using one of the following measures:

Relocate either this product or the device that is being affected by the interference.

Utilize power outlets that are on different branch (circuit breaker or fuse) circuits or install AC line filter/s.

In the case of radio or TV interference, relocate/reorient the antenna. If the antenna lead-in is 300 ohm ribbon lead, change the lead-in to co-axial type cable.

If these corrective measures do not produce satisfactory results, please contact the local retailer authorized to distribute this type of product. If you can not locate the appropriate retailer, please contact Yamaha Corporation of America, Electronic Service Division, 6600 Orangethorpe Ave, Buena Park, CA90620

The above statements apply **ONLY** to those products distributed by Yamaha Corporation of America or its subsidiaries.

(class B)

COMPLIANCE INFORMATION STATEMENT (Supplier's declaration of conformity procedure)

Responsible Party : Yamaha Corporation of America
Address : 6600 Orangethorpe Ave., Buena Park, Calif. 90620
Telephone : 714-522-9011
Type of Equipment : POWERED SPEAKER SYSTEM
Model Name : DHR15, DHR12M, DHR10

This device complies with Part 15 of the FCC Rules.

Operation is subject to the following two conditions:

- 1) this device may not cause harmful interference, and
- 2) this device must accept any interference received including interference that may cause undesired operation.

(FCC SDoC)

PRECAUTIONS

PLEASE READ CAREFULLY BEFORE PROCEEDING

Please keep this manual in a safe place for future reference.



WARNING

Always follow the basic precautions listed below to avoid the possibility of serious injury or even death from electrical shock, short-circuiting, damages, fire or other hazards. These precautions include, but are not limited to, the following:

If you notice any abnormality

- If any of the following problems occur, immediately turn off the power switch and disconnect the electric plug from the outlet.
 - The power cord or plug becomes frayed or damaged.
 - Unusual smells or smoke are emitted.
 - Some object, or water has been dropped into the product.
 - There is a sudden loss of sound during use of the product.
 - Cracks or other visible damage appear on the product.
 Then have the product inspected or repaired by qualified Yamaha service personnel.

Power supply

- Do not place the power cord near heat sources such as heaters or radiators, and do not excessively bend or otherwise damage the cord, place heavy objects on it, or place it in a position where anyone could walk on, trip over, or roll anything over it.
- Only use the voltage specified as correct for the product. The required voltage is printed on the name plate of the product.
- Use only the supplied power cord.
If you intend to use the product in an area other than in the one you purchased, the included power cord may not be compatible. Please check with your Yamaha dealer.
- Check the electric plug periodically and remove any dirt or dust which may have accumulated on it.
- Make sure to fully insert the electric plug to prevent electric shocks or fire.
- When setting up the product, make sure that the AC outlet you are using is easily accessible. If some trouble or malfunction occurs, immediately turn off the power switch and disconnect the plug from the outlet. Even when the power switch is turned off, as long as the power cord is not unplugged from the wall AC outlet, the product will not be disconnected from the power source.
- Remove the electric plug from the outlet when the product is not to be used for extended periods of time.
- Do not touch the product or the electric plug during an electrical storm.
- Be sure to connect to an appropriate outlet with a protective grounding connection. Improper grounding can result in electrical shock, fire, or damage.

Do not open

- This product contains no user-serviceable parts. Do not attempt to disassemble the internal parts or modify them in any way.

Water warning

- Do not expose the product to rain, use it near water or in damp or wet conditions, or place on it any containers (such as vases, bottles or glasses) containing liquids which might spill into any openings.
- Never insert or remove an electric plug with wet hands.

Fire warning

- Do not place any burning items or open flames near the product, since they may cause a fire.

Hearing loss

- Before turning the power of all devices on or off, make sure that all volume levels are set to the minimum. Failing to do so may result in hearing loss, electric shock, or device damage.
- When turning on the AC power in your audio system, always turn on the product LAST, to avoid hearing loss and speaker damage. When turning the power off, the product should be turned off FIRST for the same reason.



CAUTION

Always follow the basic precautions listed below to avoid the possibility of physical injury to you or others. These precautions include, but are not limited to, the following:

Power supply

- When removing the electric plug from the product or an outlet, always hold the plug itself and not the cord. Pulling by the cord can damage it.

Location and connection

- Do not place the product in an unstable position or a location with excessive vibration, where it might accidentally fall over and cause injury.
- Keep this product out of reach of children. This product is not suitable for use in locations where children are likely to be present.
- Do not block the vents. This product has ventilation holes at the rear to prevent the internal temperature from becoming too high. In particular, do not place the product on its side or upside down. Inadequate ventilation can result in overheating, possibly causing damage to the product(s), or even fire.
- To ensure proper heat dissipation of the product, when installing it:
 - Do not cover it with any cloth.
 - Do not use the product in a confined, poorly-ventilated location.
 Inadequate ventilation can result in overheating, possibly causing damage to the product(s), or even fire. Make sure that there is adequate space from the rear: at least 30 cm above, 30 cm at the sides and 30 cm behind.

- Do not place the product in a location where it may come into contact with corrosive gases or salt air. Doing so may result in malfunction.
- Before moving the product, remove all connected cables.
- When transporting or moving the DHR15, always use two or more people. Attempting to lift the product by yourself may result in injuries, such as back injuries, or cause the product to be dropped and broken, which could lead to other injuries.
- Do not use the speaker's handles for suspended installation. Doing so can result in damage or injury.
- Do not hold the bottom of the product when transporting or moving it. In doing so, you may pinch your hands under the product, and result in injury.
- Do not press the rear panel of the product against the wall. Doing so may cause the plug to come in contact with the wall and detach from the power cord, resulting in short circuiting, malfunction, or even fire.
- Always consult qualified Yamaha service personnel if the product installation requires construction work. Improper installation might cause accidents, injuries, damage or malfunction of this product.

Maintenance

- Remove the power plug from the AC outlet when cleaning the product.

Handling caution

- Do not insert your fingers or hands in any gaps or openings on the product (ports).
- Do not rest your weight on the product or place heavy objects on it.
- Do not operate the product if the sound is distorting. Prolonged use in this condition could cause overheating and result in fire.

The model number, serial number, power requirements, etc., may be found on or near the name plate, which is at the rear of the unit. You should note this serial number in the space provided below and retain this manual as a permanent record of your purchase to aid identification in the event of theft.

Model No.

Serial No.

(rear_en_01)

NOTICE

To avoid the possibility of malfunction/damage to the product or damage to other property, follow the notices below.

■ Handling and maintenance

- Do not use the product in the vicinity of a TV, radio, or other electric products. Otherwise, the product, TV, or radio may generate noise.
- Do not expose the product to excessive dust or vibration, or extreme cold or heat, in order to prevent the possibility of panel disfiguration, unstable operation, or damage to the internal components.
- Do not install in locations where temperature changes are severe. Otherwise, condensation may form on the inside or the surface of the product, causing it to break or deform the wood. Do not leave condensation on the wood; wipe immediately with a soft cloth.
- If there is reason to believe that condensation might have occurred, leave the product for several hours without turning on the power until the condensation has completely dried out, in order to prevent possible damage.
- Do not touch the speaker driver unit, since it might cause malfunction.
- Air blowing out of the bass reflex ports (hole or holes at the front) is normal, and often occurs when the speaker is handling program material with heavy bass content.
- Do not place the speaker face down.
- When cleaning the product, use a dry and soft cloth. Do not use paint thinners, solvents, cleaning fluids, or chemical-impregnated wiping cloths, since this might cause alteration or discoloration.
- Always turn the power off when the device is not in use.

Information

■ About functions/data bundled with the product

- Even when the [I / ⏻] (power) switch is in standby status (POWER indicator is off), electricity is still flowing to the product at the minimum level. When you are not using the product for a long time, make sure you unplug the power cord from the wall AC outlet.
- XLR-type connectors are wired as follows (IEC60268 standard): pin 1: ground, pin 2: hot (+), and pin 3: cold (-).

■ About this manual

- The illustrations as shown in this manual are for instructional purposes only.
- The company names and product names in this manual are the trademarks or registered trademarks of their respective companies.
- Software may be revised and updated without prior notice.

■ About disposal

- This product contains recyclable components. When disposing of this product, please contact the appropriate local authorities.

Yamaha cannot be held responsible for damage caused by improper use or modifications to the product.

Introduction

Thank you for purchasing the Yamaha DHR series Powered Loudspeaker. These products are designed for live performance, sound reinforcement and fixed installation sound system applications. This manual explains how to install, set up, and configure the connections for the installers, constructors, or general users familiar with speakers. Please read this manual thoroughly before you begin using this product in order to get the most out of its various functions. After reading this manual, please keep it available for future reference.

NOTE

The example illustrations used in this manual are taken from the DHR15, if not otherwise specified.

Contents

PRECAUTIONS	3	Installation Examples	13
Introduction	5	Troubleshooting	14
Main Features	5	General Specifications (English only)	131
Included Accessories	5	Block Diagram	133
Controls and Connectors	6	Dimensions	134
Setup Examples	9		

Main Features

- **Sophisticated DSP processing**

Our proprietary sound-processing technology, called FIR-X Tuning, utilizes a linear-phase FIR filter—delivering excellent sound quality with high resolution and a smooth frequency response that is unaffected by phase interference near the cross-over point.

- **Easy sound optimization**

D-CONTOUR (Dynamic CONTOUR) constantly monitors the output of multiple frequency bands, and applies the optimum EQ adjustments to each according to the listener's preferences. There are two modes: an FOH/MAIN mode for use as a main speaker, and a MONITOR mode for use as a floor monitor, letting you select the preset tuning optimized for each application.

- **Various input/output connectors and convenient, simple mixing function**

The comprehensive set of connectors—including XLR for a mixer, phone for a musical instrument, and RCA pin for an audio player—provides maximum flexibility in use with a wide variety of applications. Also, the DHR features simple mixing functionality, enabling you to select either a direct output of channel 1 (CH1) (parallel connection) or a mixed output of CH1 and CH2, for convenient system setup.

- **Lineup for a variety of applications**

The models are optimized for various applications: the DHR15 is ideal for use as a main speaker delivering powerful sound and the DHR12M with its sound character optimized for monitoring is ideal for use as a compact floor monitor. The rotatable horn equipped DHR10 is ideal for use as a fixed installation, and can be installed vertically or horizontally with optional brackets.

- **High-grade and durable wood cabinet for superior sound**

The naturally textured wood cabinet of the DHR features a durable coating with high damage resistance to protect the cabinet from scratches and bumps during transport, installations and removal.

Included Accessories

- AC power cord
- Owner's manual (this book)

Controls and Connectors

Rear

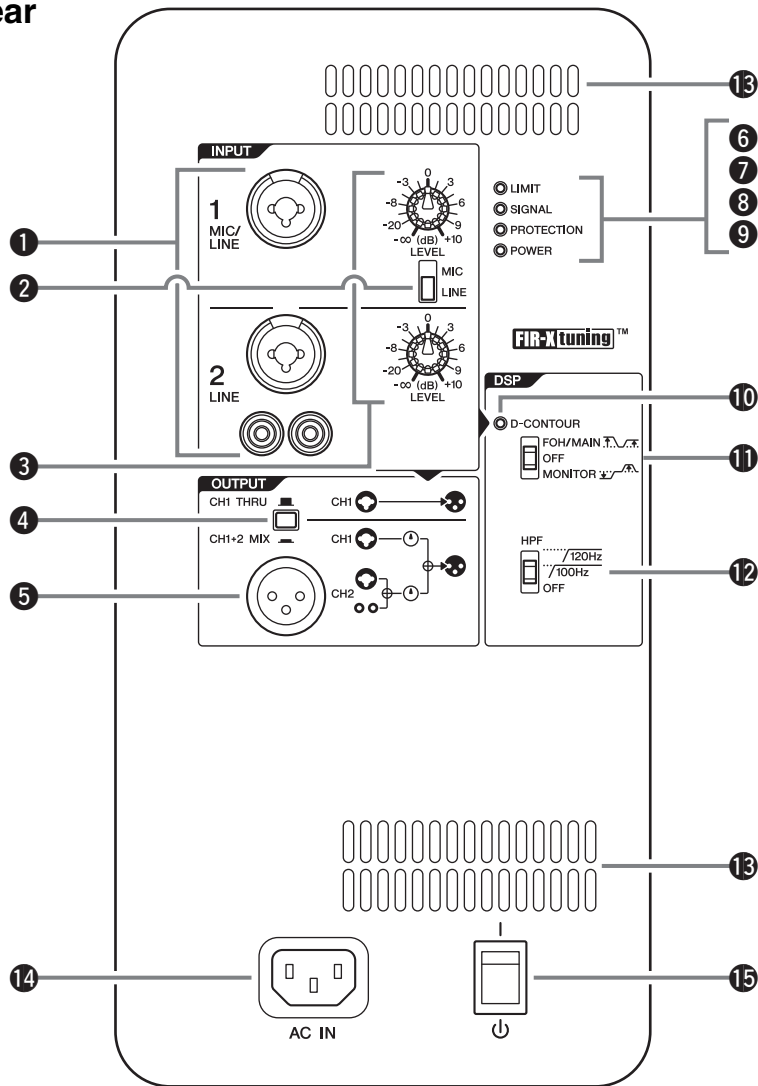

1 Input jacks (CH1 and CH2)

These are balanced combo jacks that support both XLR and phone plugs (both CH1 and CH2), and RCA pin plugs (CH2 only). For the combo jacks, connect a mixer, microphone, or digital musical instrument such as a keyboard. For RCA-pin jacks, connect a device such as an MP3 player or a CD player. For devices with high level signals such as a mixer, connect to CH2, or connect to CH1 then set the [MIC/LINE] switch (2) to [LINE].

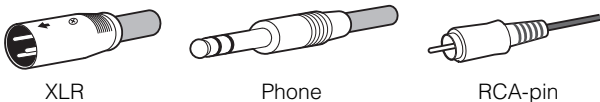

XLR

Phone

RCA-pin

NOTE

For CH2, inputs to the combo jack and to the RCA pin jacks will be mono mixed at a fixed balance. If you want to change the balance, adjust the volume of the connected sound source.

2 [MIC/LINE] switch

Set this switch to [MIC] or [LINE] for the CH1 jack, depending on the level of the input signal. For low-level signals (such as microphones), set the switch to [MIC]. For high-level signals (such as mixer), set the switch to [LINE].

3 [LEVEL] knobs

Adjust the level of each input jack (1).

4 Output switch

Selects the output signal sent to the output jack (5).

[CH1 THRU]: Delivers the direct output signal of CH1 only. Signal from CH2 will not be output.

[CH1+2 MIX]: Outputs the mixed signals of CH1 and CH2.

5 Output jack

This is a balanced XLR jack. This can be used to connect another DHR speaker. Outputs the signal selected by 4 output switch.

6 [LIMIT] indicator

Indicates (lit in red) that the limiter is on when the output voltage of the amplifier has exceeded the maximum level, or when excessive integral power consumption is detected. If this indicator stays lit, lower the input level.

NOTE

Integral power consumption refers to the sum of power provided to the speaker driver per unit time.

7 [SIGNAL] indicator

Indicates (lit in green) when an audio signal exceeding the threshold has been detected.

8 [PROTECTION] indicator

Indicates (lit in red) when the protection circuit is active. The protection circuit will be activated and the speaker outputs will be muted in the situations listed below.

- If amplifier overheating is detected
- If overcurrent is detected
- When turning the power on; the protection circuit will be activated for a few seconds to prevent noise. The indicator turns off when the power supply has started normally.

If the protection circuit has engaged, waiting until the amplifier cools down or powering off and on again will return to normal operation. If the unit does not return to normal operation, please contact your Yamaha dealer.

9 [POWER] indicator

Indicates (lit in green) when the [I / ⏻] (power) (15) switch is turned on.

10 [D-CONTOUR] indicator

Indicates (lit in yellow) when the [D-CONTOUR] switch (11) is set to [FOH/MAIN] or [MONITOR].

11 [D-CONTOUR] switch

Selects one of the D-CONTOUR (Dynamic CONTOUR) presets.

[FOH/MAIN]: Boosts the high and low frequency components so that the frequency response is suitable for a main speaker.

[MONITOR]: Reduces the low frequency range, which could otherwise tend to be boomy if the speaker is set directly on the floor. This enables you to hear mid and high frequency ranges clearly when using as a floor monitor.

[OFF]: Turns off D-CONTOUR. This is a generic frequency response setting.

12 [HPF] switch

Selects the cutoff frequency of the high pass filter. If you set this switch to [120Hz] or [100Hz], the low frequency components below each threshold will be cut. If you use the unit alone, set this switch to [OFF]. If you plan to use the unit along with a subwoofer, we recommend that you set this switch to [120Hz] or [100Hz].

13 Vent

The unit contains a cooling fan.

**CAUTION**

Do not block the vents. This product has ventilation holes at the rear to prevent the internal temperature from becoming too high. Inadequate ventilation can result in overheating, possibly causing damage to the product(s), or even fire.

14 [AC IN] socket

Connect the supplied power cord in the order below. Before connecting the power cord, make sure that the DHR power is turned off.

1. Insert the plug of the power cord into this socket.
2. Plug the other end of the cord into the AC outlet.

NOTE

When removing the power cord, perform this procedure in reverse order.

**WARNING**

Use only the supplied power cord.

**CAUTION**

Turn off the power before you connect or disconnect the power cord.

15 [I / ⏻] (power) switch

Turns the power supply on [I] or sets it to standby [⏻]. First, turn on the power of the connected sound source (external device), then the unit. When turning off the power, reverse the order by turning off the power of the unit first and then the connected sound source (external device).

NOTICE

Even when the switch is in the standby position, a small amount of electricity is still flowing to the unit.

NOTE

- Rapidly turning the unit on and off in succession can cause it to malfunction. After turning the unit off, wait for about 5 seconds before turning it on again.
- If you are using multiple units, turn on the power to each unit one by one. If you turn on the power to multiple units simultaneously, a temporary drop in the power voltage may occur, possibly resulting in abnormal operation of the units.

Rear (DHR15)

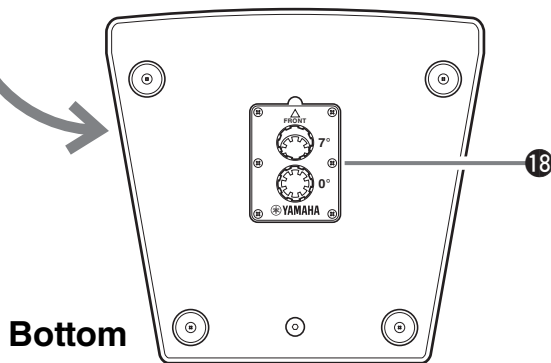
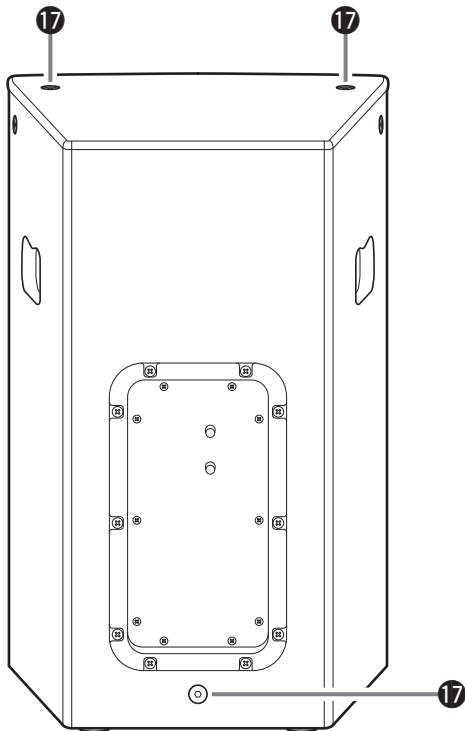

Rear (DHR10)

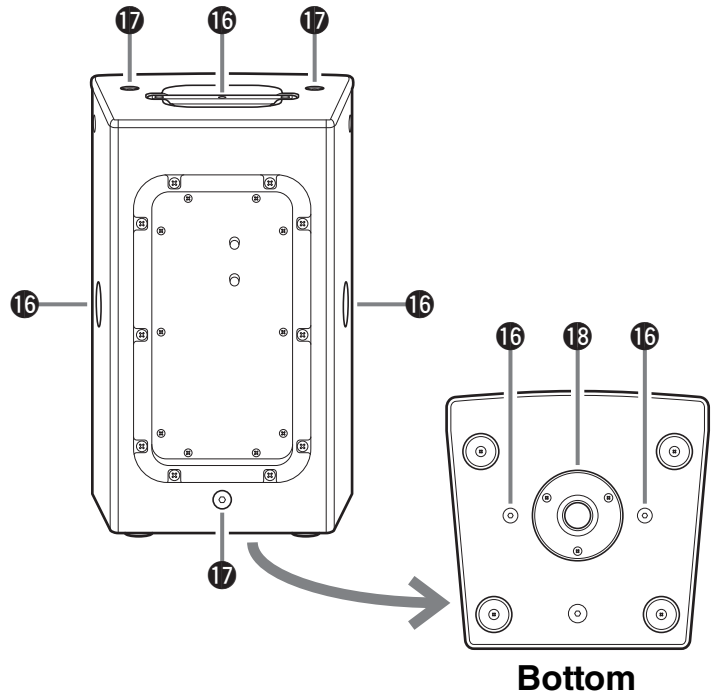

Side (DHR12M)

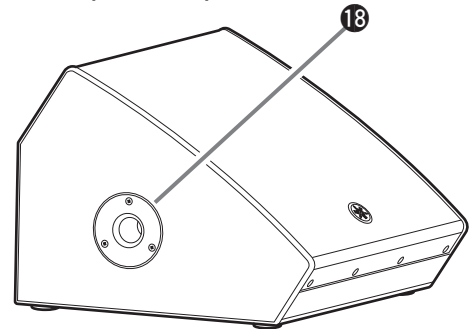

16 Screw holes for U-bracket M8 (DHR10 only)

For installing with the separately sold U-brackets.

17 Screw holes for eye bolts M10 (DHR15 and DHR10 only)

For installing the speaker using commercially available eye bolts (M10).

18 Pole socket

This socket adapts to commercially available speaker stands and speaker poles of 35 mm diameter.

Tiltable pole socket (DHR15 only)

This mount has two pole sockets. You can choose the angle of the speaker so that it is positioned horizontal to the floor or tilting down toward the floor by 7 degrees.

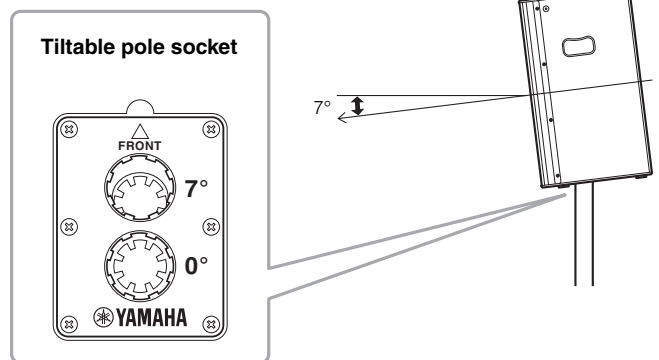

Setup Examples

System with two DHRs and subwoofers—using the DHR15

This system is the most suitable for a main speaker system. If desired, you can add other DHR12M to create a floor monitor system.

Main application: small-sized live venue, house of worship, event site

NOTE

We recommend to use Yamaha DXS18 as a subwoofer. In this case, we recommend that the DHR15's HPF cutoff frequency and the DXS18's LPF cutoff frequency are set to the same settings; however, you can adjust it as desired.

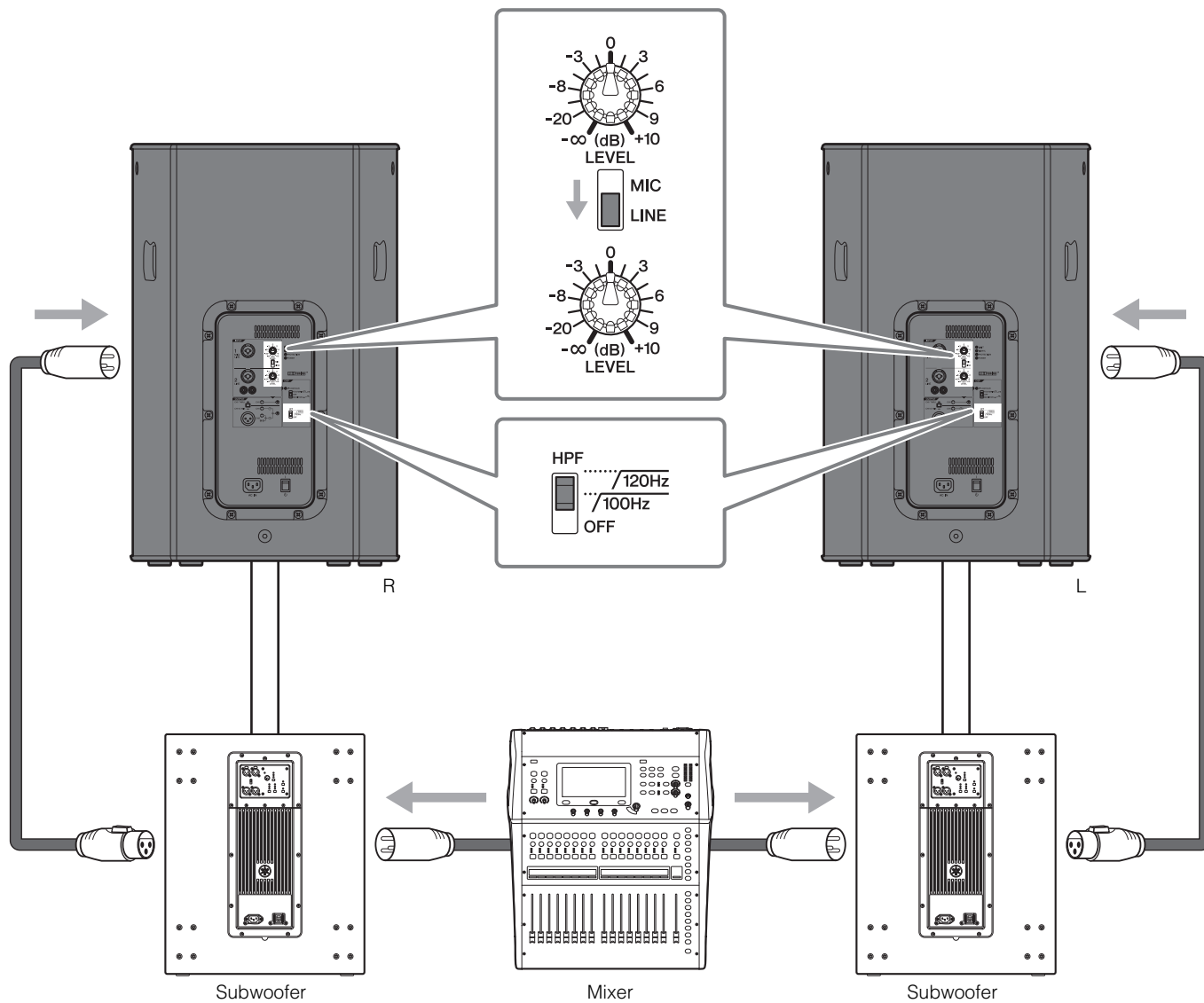

Floor monitor system—using the DHR12M

This system is suitable for a performer's monitoring system. For use as a vocal monitor, set the [D-CONTOUR] switch to [MONITOR].

If necessary, you can additionally connect up to four speakers in parallel. In this case we recommend that the signal is input to CH1 and the output switch is set to [CH1 THRU].

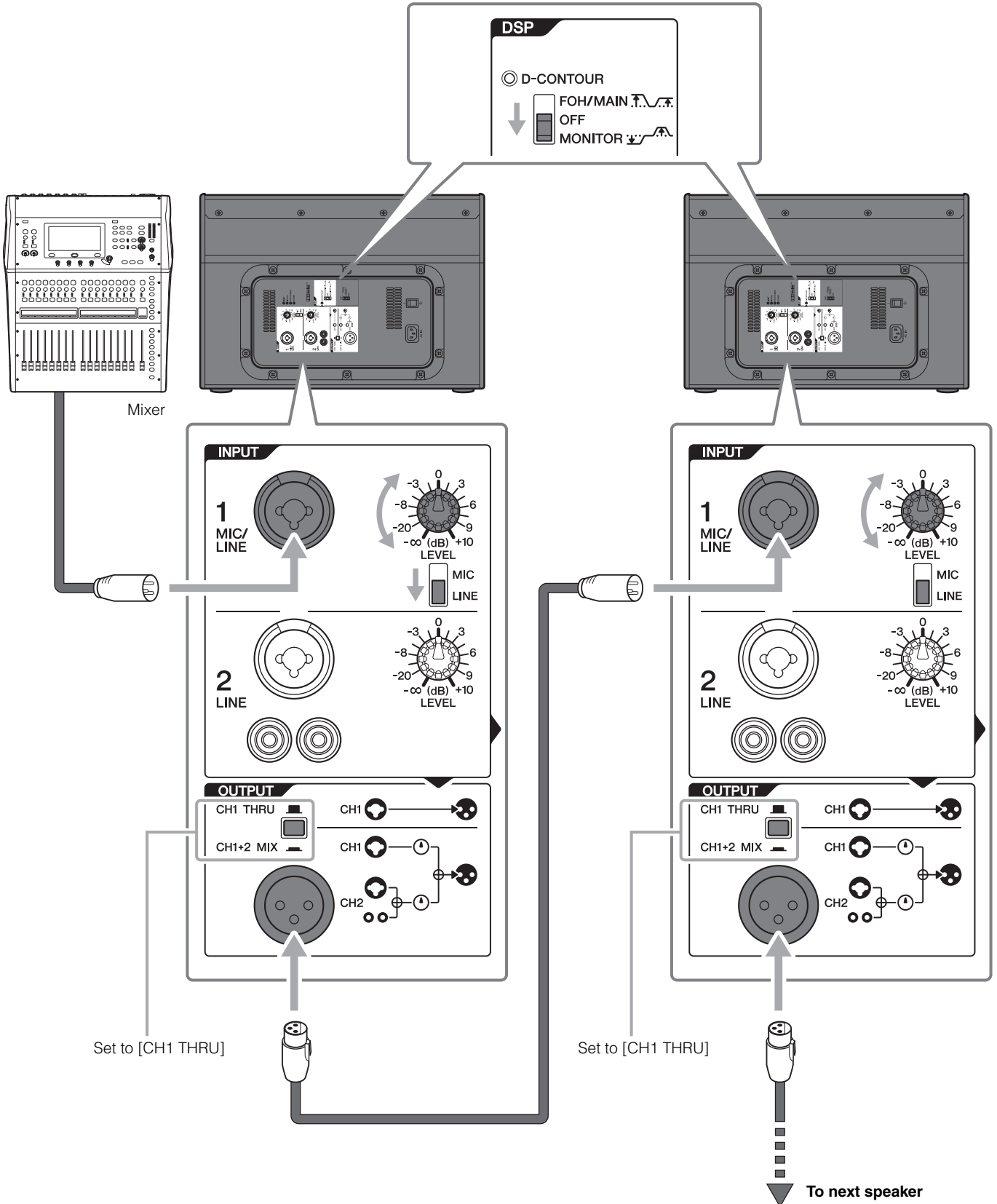

Fixed installations—using the DHR10

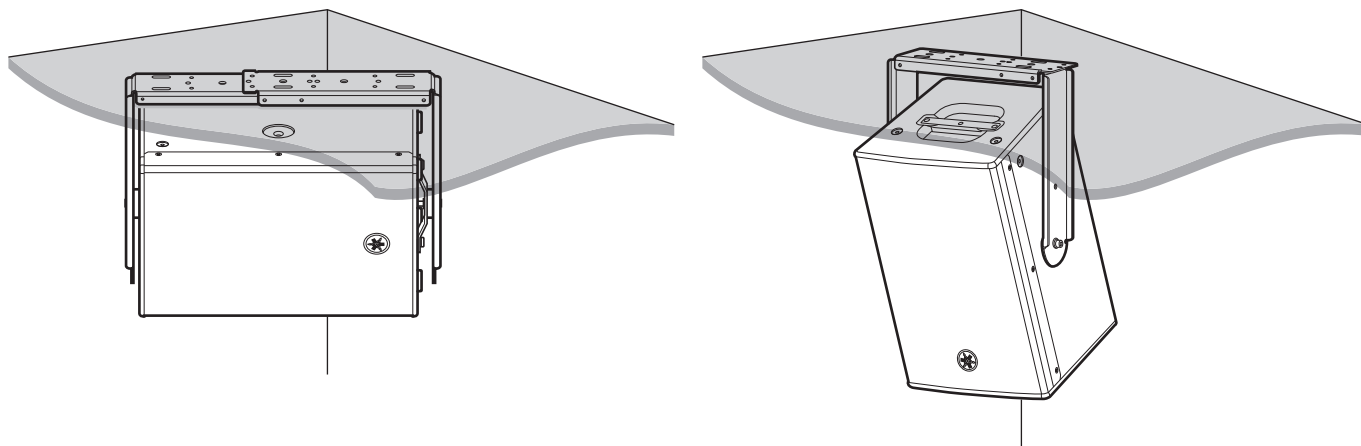

DHR10 can be neatly installed on a ceiling or a wall, either horizontally or vertically, with the separately sold Yamaha UB-DXRDR10 U-bracket. For instructions on installing the U-bracket, refer to the corresponding manual for the UB-DXRDR10.

NOTE

The UB-DXRDR10 can be used together with separately sold optional brackets, such as the Yamaha BBS251 Baton Bracket.

Also, the DHR10 features a rotatable horn (90 degrees). When shipped from the factory, the directivity of DHR10 in a vertical orientation is the setting which makes the sound expand in a horizontal direction, and inhibits or narrows the sound in a vertical direction. We recommend changing the directivity by rotating the horn when you want to install the DHR10 horizontally and broaden the directivity.

Rotatable Horn (DHR10 only)

1. Using a No. 2 Phillips head screwdriver, remove all fixing screws on the grille, and remove the grille from the speaker.

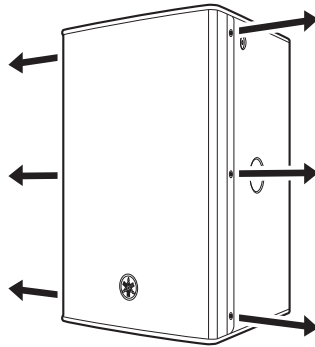

2. Using a No. 2 Phillips head screwdriver, remove all screws installed on the horn and pull the horn out from the speaker.

NOTE

Make sure not to push the screws too strongly with the Phillips head screwdriver. This may cause the nuts inside the cabinet to fall off.

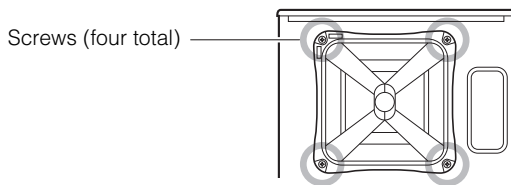

3. Rotate the horn 90 degrees, and re-install the horn to the speaker, reversing the steps above.

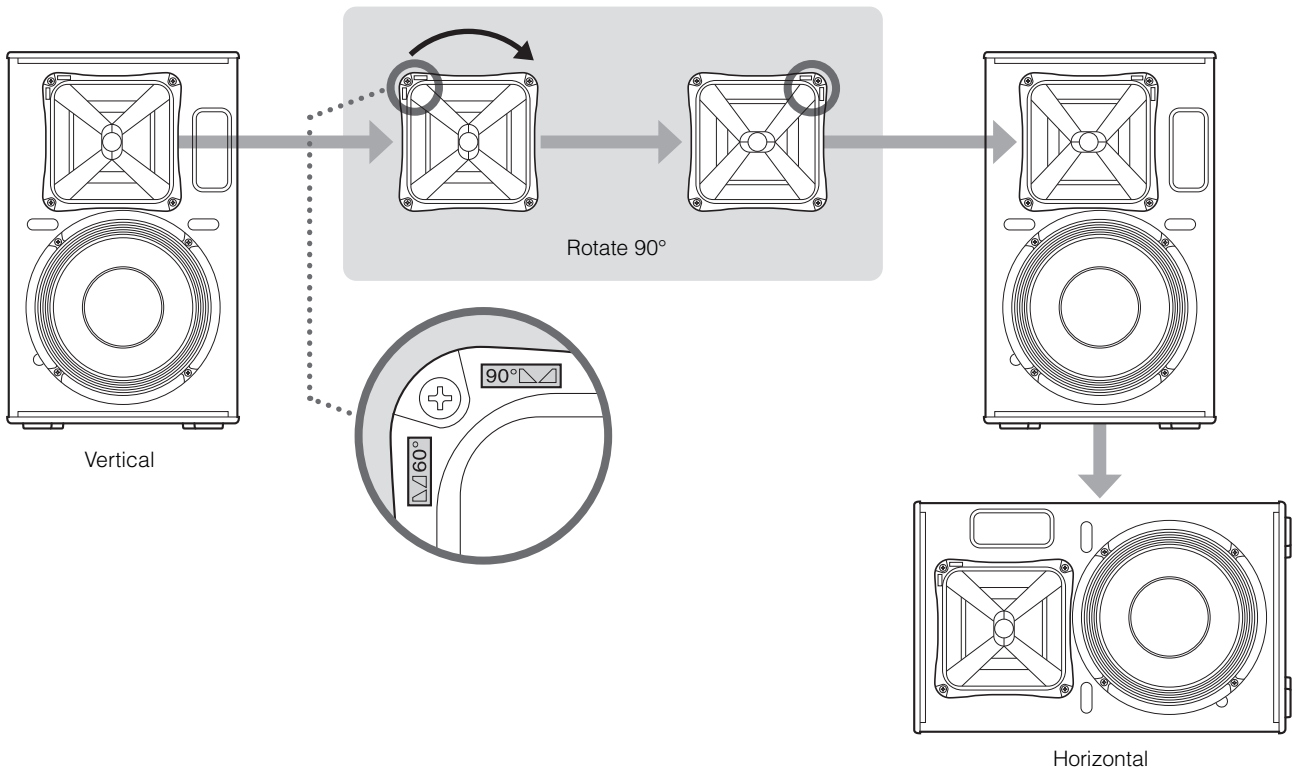

Installation Examples



CAUTION

- Before doing any installation or construction work, consult with your Yamaha dealer.
- The installation should be checked thoroughly at regular intervals. Some fittings may deteriorate over extended periods of time due to wear and/or corrosion.
- When choosing the installation location, suspension wire and mounting hardware, make sure all are strong enough to support the weight of the speaker.
- Make sure to take precautionary measures using wires to prevent the speaker from falling down in the event of an installation failure.
- When installing the safety wire to the wall, install it higher than the wire's attachment point on the speaker, with as little slack as possible. If the wire is too long, and the speaker happens to fall, the wire may snap as a result of too much strain.
- Make sure to use eye bolts according to the standards and safety regulations in your area.

NOTE

Safety wire can be attached to the screw holes for eye bolts and to the screw holes for the U-bracket (DHR10 only) located at the center of the handle. The illustration below is an example of using the U-bracket.

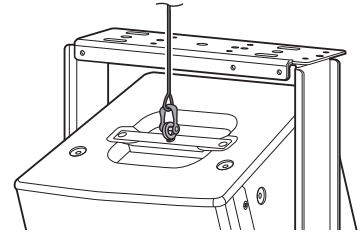

Yamaha cannot be held responsible for damage or injury caused by insufficient strength of the support structure or improper installation.

Suspended Installation Using Eye Bolts (DHR15 and DHR10 only)

Attach commercially available long eye bolts (30–50 mm in length) to the screw holes located at the top (two locations) and on the lower rear (one location). The screw diameter is M10. Keep in mind that you will need two points at the top to suspend the unit.

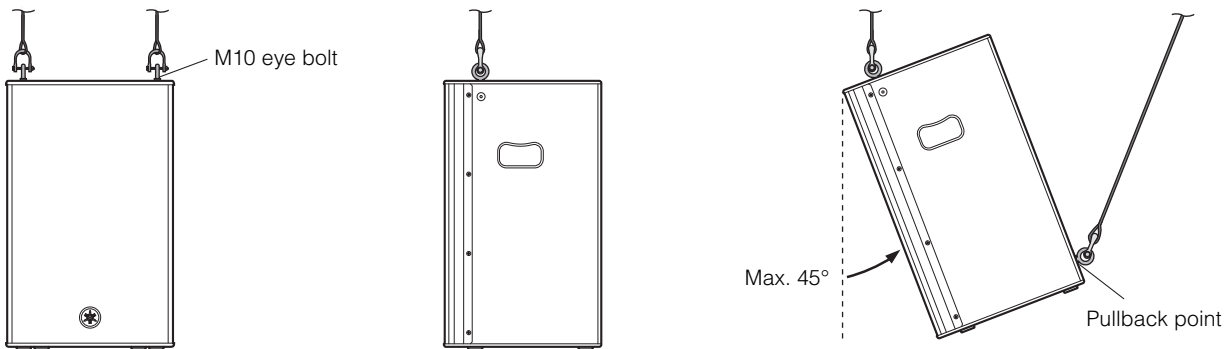

■ Pullback point

Lower rear

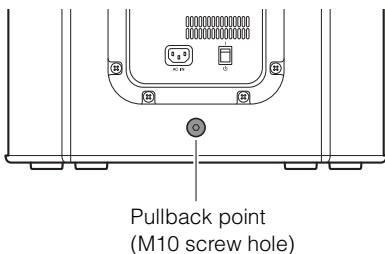

■ Securing the eye bolts

Remove the flat-head screws tightened at the time of factory shipment, and then insert the eye bolts through the washers when attaching them.

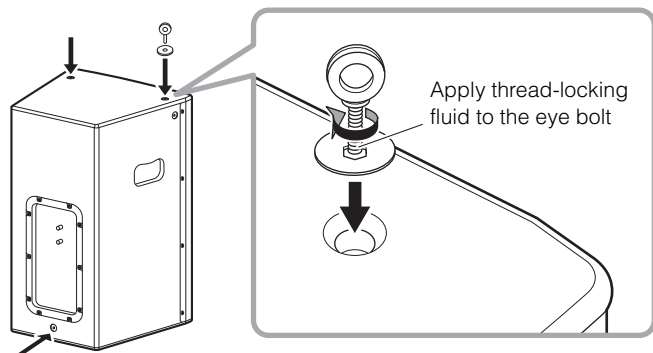

NOTE

The screw holes for eye bolts go through the cabinet wall. When not using eye bolts, tighten the flat-head screws in order to prevent air leaks.

■ Suspension angle

The strength of an eye bolt differs depending on the suspension angle. Make sure to use eye bolts within a range of 0 to 45 degrees from a right angle (as shown).

Correct: Within 45° from a right angle

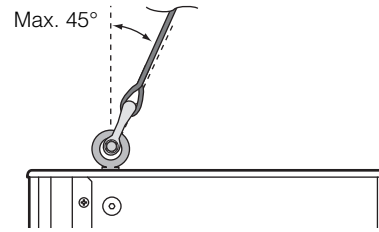
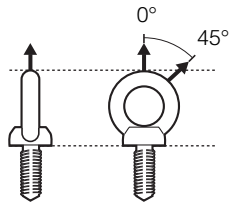

Incorrect: Do not suspend the eye bolts as shown in the illustrations below.



Prohibited

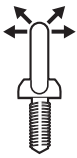

Prohibited

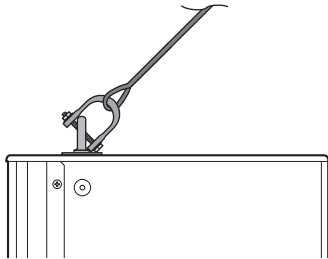

Prohibited

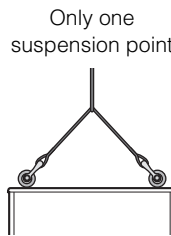

Prohibited

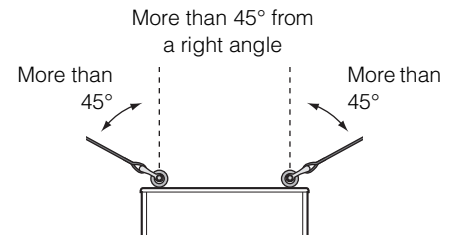

Troubleshooting

Symptom		Possible causes	Possible solution
Power does not turn on.		The power cord is not connected properly.	Connect the power cord all the way in so that it is firmly in place.
Power suddenly went off.		The protection system has been activated, shutting down the power supply.	Turn off the power, wait until the amplifier cools down, and then turn on again.
No Sound.		The cable is not connected properly.	Connect the cable all the way in so that it is firmly in place.
Sound is interrupted suddenly.		The protection circuit has been activated, muting the output.	Wait until the amplifier cools down. If the unit won't automatically reset itself, turn off the power, and then on again.
Sound howls (feedback).		A microphone is directed toward the speaker.	Aim the speaker away from the area where the microphone picks up sound.
		Sound is amplified too much.	Lower the volume of input device and locate the microphone more closely to the sound source.
Each speaker sound differs (if multiple speakers are used).		Settings for each speaker differ.	Set the [HPF] switch and [D-CONTOUR] switch of each speaker to the same positions.
Sound is distorted.	The [LIMIT] indicator is off.	Input volume is excessive.	When the [MIC/LINE] switch is set to [MIC], and even if you lower the volume fully the sound is still distorted, set the switch to the [LINE] position. If the sound is still distorted even if the switch has been set to [LINE], lower the volume of the connected input devices.
	The [LIMIT] indicator is on.	Output volume is excessive.	Turn the [LEVEL] knob to lower the output level to a point so that the [LIMIT] indicator lights only occasionally.
The microphone volume is too low.		The [MIC/LINE] switch is set to [LINE].	Set the [MIC/LINE] switch to the [MIC] position.
Low and high frequency are unbalanced.		The output limiter is active.	Lower the input level or the output level until the [LIMIT] indicator lights occasionally.

If any specific problem should persist, however, please contact your Yamaha dealer.

General Specifications

General	DHR15	DHR12M	DHR10
System Type	2-way, Bi-amp Powered Speaker, Bass-reflex Type		
Frequency Range (-10 dB)	44 Hz-20 kHz	55 Hz-20 kHz	52 Hz-20 kHz
Coverage Angle	H90° × V60°	H90° × V90°	H90° × V60° (Rotatable)
Crossover Type	FIR-X tuning™ (Linear Phase FIR Filter)		
Crossover Frequency	1.8 kHz	1.8 kHz	1.9 kHz
Measured Maximum SPL (Peak) IEC noise@1m	131 dB SPL	129 dB SPL	128 dB SPL

Transducer	DHR15	DHR12M	DHR10
LF	Diameter	15" Cone	12" Cone
	Voice coil	2.5"	2.5"
	Magnet	Ferrite	
HF	Diaphragm	1.4"	1.75"
	Type	1" Throat Compression Driver	1" Throat Compression Driver Coaxial
	Magnet	Ferrite	

Enclosure	DHR15	DHR12M	DHR10
Material, Color	Plywood, Black, Polyurea coating		
Floor Monitor Angle	—	57°	—
Dimensions (W×H×D, with rubber feet)	432 × 692 × 405 mm	500 × 343 × 454 mm	305 × 494 × 300 mm
Net Weight	24.0 kg	16.5 kg	15.0 kg
Handles	Side × 2	Side × 1	Top × 1
Pole Socket	35 mm × 2 (0 and 7 degree)	35 mm	35 mm
Rigging Points	Top × 2, Rear × 1 (Fit for M10 Eyebolts)	—	Top × 2, Rear × 1 (Fit for M10 Eyebolts)
Optional Speaker Bracket	—	—	UB-DXRDR10

Amplifier	DHR15	DHR12M	DHR10
Amplifier Type	Class-D		
Power Rating *1	Dynamic	1000 W (LF: 800 W, HF: 200 W)	700 W (LF: 500 W, HF: 200 W)
	Continuous	465 W (LF: 400 W, HF: 65 W)	325 W (LF: 260 W, HF: 65 W)
Cooling	Fan Cooling, 4 Speeds.		
AD/DA	24 bit 48 kHz Sampling		
HPF	OFF, 100 Hz, 120 Hz, 24 dB/Oct.		
DSP Preset	D-CONTOUR: FOH/MAIN, MONITOR, OFF		
Protection	Speaker	Clip Limiting, Integral Power Protection, DC-fault	
	Amplifier	Thermal, Output Over Current	
	Power Supply	Thermal, Output Over Voltage, Output Over Current	
Connectors	Input	Input1: Combo × 1, Input2: Combo × 1, RCA PIN × 2 (Unbalanced)	
	Output	Output: XLR3-32 × 1 (CH1 Parallel Through or CH1+CH2 Mix)	
Input Impedance	INPUT1: LINE: 10 kΩ, MIC: 3 kΩ, INPUT2: 10 kΩ		
Input Sensitivity (LEVEL: Maximum)	INPUT1: LINE: 0 dBu, MIC: -32 dBu, INPUT2: 0 dBu		
Input Sensitivity (LEVEL: Center)	INPUT1: LINE: +10 dBu, MIC: -22 dBu, INPUT2: +10 dBu		
Maximum Input Level	INPUT1: LINE: +24 dBu, MIC: -8 dBu, INPUT2: +24 dBu		
Controls	LEVEL × 2, LINE/MIC, HPF, D-CONTOUR, THRU/MIX, POWER		
Idle Power Consumption	18 W		18 W
1/8 Power Consumption	74 W		60 W
Power Requirements	100 V, 110-120 V, 220-240 V, 110 V/127 V/220 V (Brazil), 50/60 Hz		

0 dBu is referenced to 0.775 Vrms.

*1 Power rating (120 V, 25°C). This is total value of individual output power.

This value is measured by releasing the software protection.

Dynamic: Total peak power of individual outputs. Measured at minimum load impedance, with protection released.

Continuous: Measured at nominal impedance, with protection activated.

- * The contents of this manual apply to the latest specifications as of the publishing date. To obtain the latest manual, access the Yamaha website then download the manual file.
- * Der Inhalt dieser Bedienungsanleitung gilt für die neuesten technischen Daten zum Zeitpunkt der Veröffentlichung. Um die neueste Version der Anleitung zu erhalten, rufen Sie die Website von Yamaha auf und laden Sie dann die Datei mit der Bedienungsanleitung herunter.
- * Le contenu de ce mode d'emploi s'applique aux dernières caractéristiques techniques connues à la date de publication du manuel. Pour obtenir la version la plus récente du manuel, accédez au site Web de Yamaha puis téléchargez le fichier du manuel concerné.
- * El contenido de este manual se aplica a las últimas especificaciones según la fecha de publicación. Para obtener el último manual, acceda al sitio web de Yamaha y descargue el archivo del manual.
- * O conteúdo deste manual se aplica às especificações mais recentes a partir da data de publicação. Para obter o manual mais recente, acesse o site da Yamaha e faça o download do arquivo do manual.
- * Il contenuto del presente manuale si applica alle ultime specifiche tecniche a partire dalla data di pubblicazione. Per ottenere la versione più recente del manuale, accedere al sito Web Yamaha e scaricare il file corrispondente.
- * В содержании данного руководства приведены последние на момент публикации технические характеристики. Для получения последней версии руководства посетите веб-сайт корпорации Yamaha и загрузите файл с руководством.
- * 본 설명서의 내용은 발행일 현재 최신 사양을 기준으로 하고 있습니다. 최신 설명서를 가져오려면 Yamaha 웹사이트에 접속 후 해당 설명서 파일을 다운로드 받으십시오.
- * 本書は、発行時点での最新仕様で説明しています。最新版は、ヤマハウェブサイトからダウンロードできます。

Block Diagram

电路图

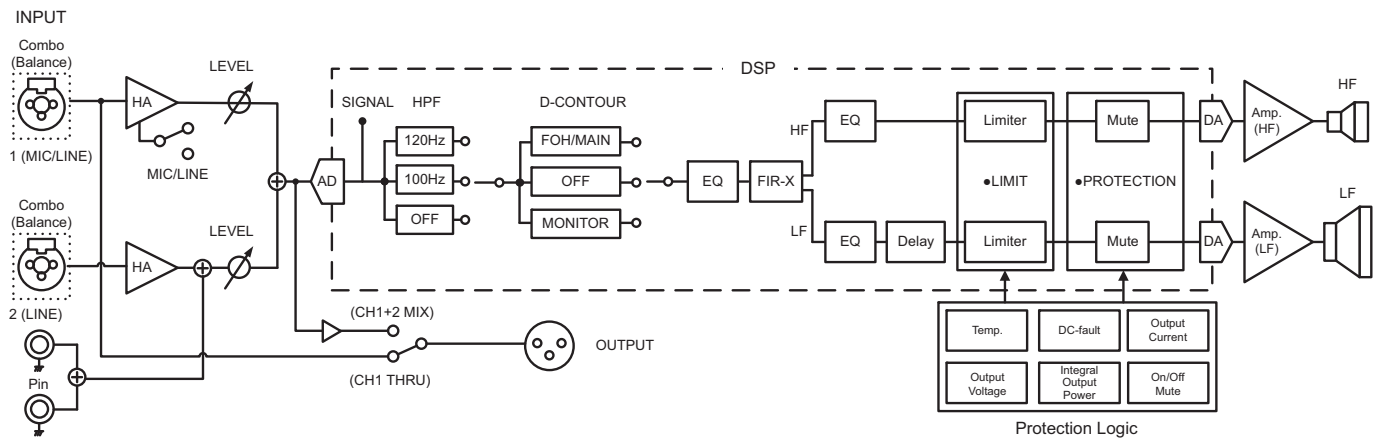

Dimensions

外形尺寸

■ DHR15

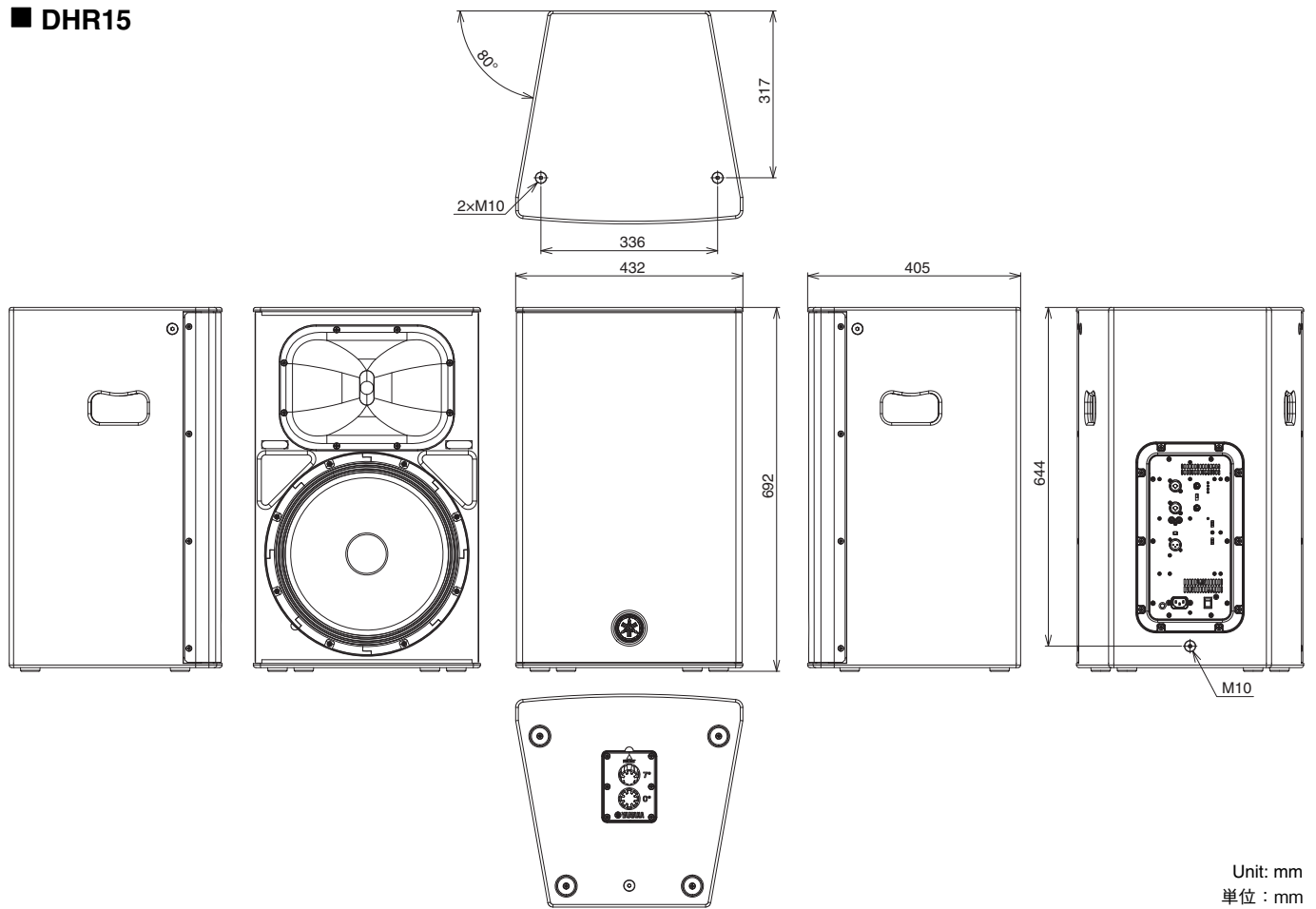

Unit: mm
单位: mm

■ DHR12M

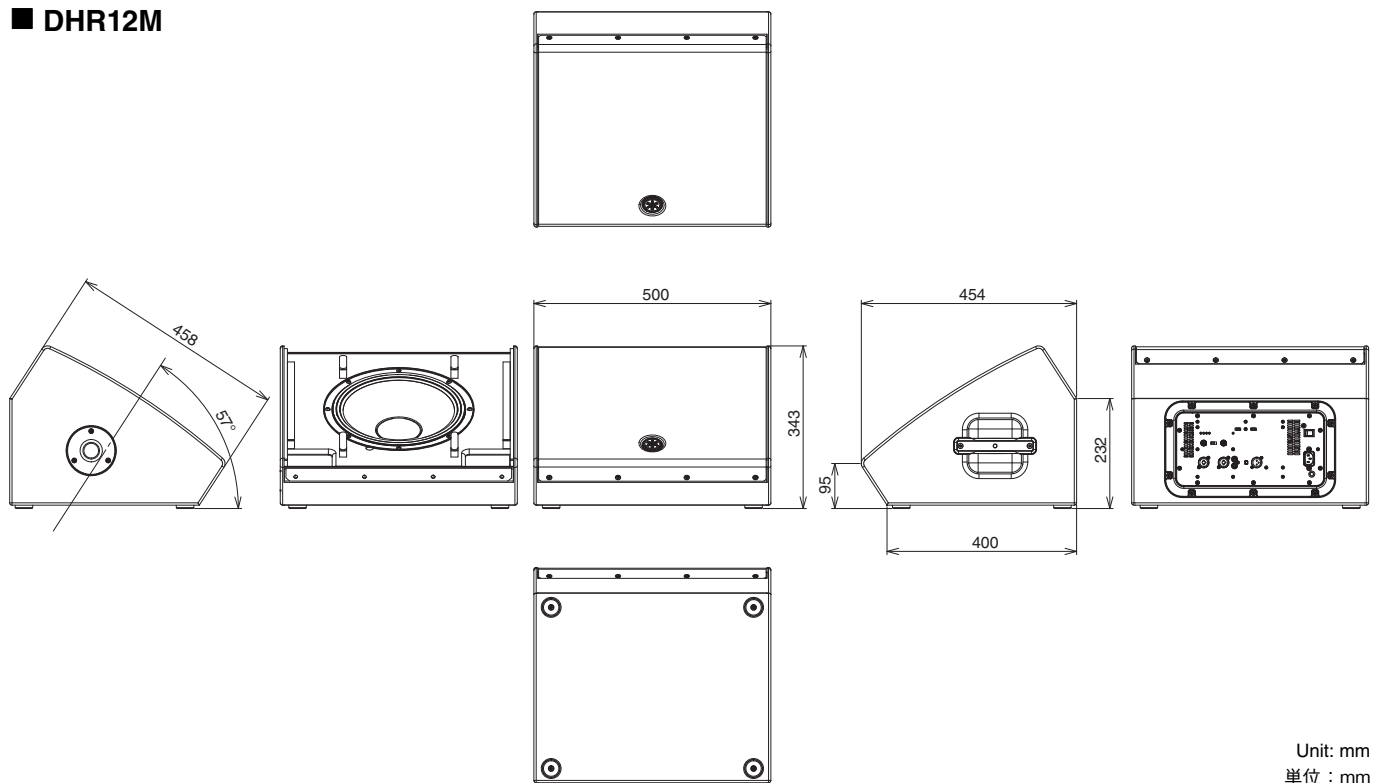

Unit: mm
单位: mm

■ DHR10

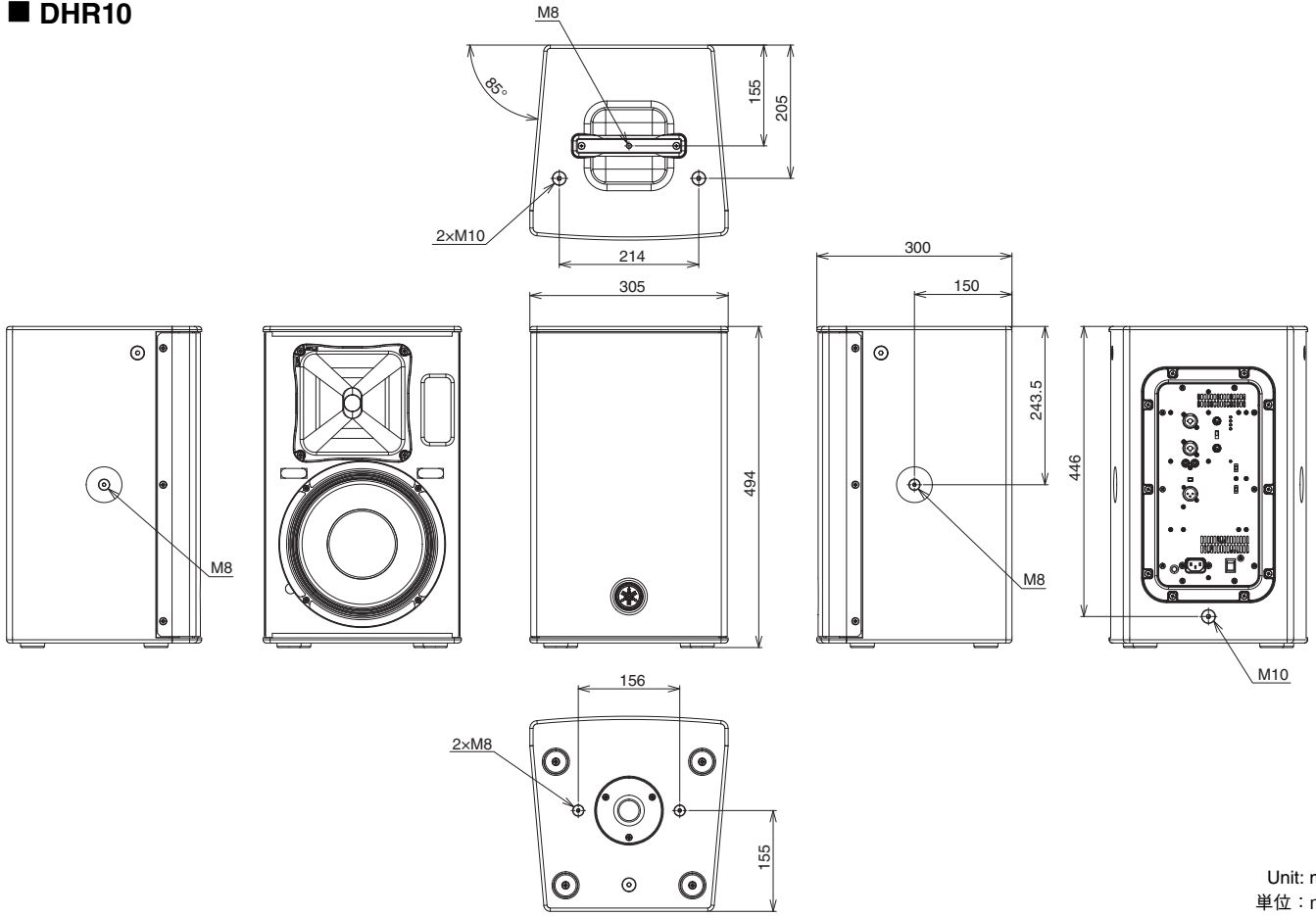

Unit: mm
 単位 : mm

Important Notice: Guarantee Information for customers in European Economic Area (EEA) and Switzerland

<p>Important Notice: Guarantee Information for customers in EEA* and Switzerland</p> <p>For detailed guarantee information about this Yamaha product, and Pan-EEA* and Switzerland warranty service, please either visit the website address below (Printable file is available at our website) or contact the Yamaha representative office for your country. * EEA: European Economic Area</p>	English
<p>Wichtiger Hinweis: Garantie-Information für Kunden in der EWR* und der Schweiz</p> <p>Für nähere Garantie-Information über dieses Produkt von Yamaha, sowie über den Pan-EWR*- und Schweizer Garantieservice, besuchen Sie bitte entweder die folgend angegebene Internetadresse (eine druckfähige Version befindet sich auch auf unserer Webseite), oder wenden Sie sich an den für Ihr Land zuständigen Yamaha-Vertrieb. *EWR: Europäischer Wirtschaftsraum</p>	Deutsch
<p>Remarque importante: informations de garantie pour les clients de l'EEE et la Suisse</p> <p>Pour des informations plus détaillées sur la garantie de ce produit Yamaha et sur le service de garantie applicable dans l'ensemble de l'EEE ainsi qu'en Suisse, consultez notre site Web à l'adresse ci-dessous (le fichier imprimable est disponible sur notre site Web) ou contactez directement Yamaha dans votre pays de résidence. * EEE : Espace Economique Européen</p>	Français
<p>Belangrijke mededeling: Garantie-informatie voor klanten in de EER* en Zwitserland</p> <p>Voor gedetailleerde garantie-informatie over dit Yamaha-product en de garantieservice in heel de EER* en Zwitserland, gaat u naar de onderstaande website (u vindt een afdrukbaar bestand op onze website) of neemt u contact op met de vertegenwoordiging van Yamaha in uw land. * EER: Europese Economische Ruimte</p>	Nederlands
<p>Aviso importante: información sobre la garantía para los clientes del EEE* y Suiza</p> <p>Para una información detallada sobre este producto Yamaha y sobre el soporte de garantía en la zona EEE* y Suiza, visite la dirección web que se incluye más abajo (la versión del archivo para imprimir esta disponible en nuestro sitio web) o póngase en contacto con el representante de Yamaha en su país. * EEE: Espacio Económico Europeo</p>	Español
<p>Avviso importante: informazioni sulla garanzia per i clienti residenti nell'EEA* e in Svizzera</p> <p>Per informazioni dettagliate sulla garanzia relativa a questo prodotto Yamaha e l'assistenza in garanzia nei paesi EEA* e in Svizzera, potete consultare il sito Web all'indirizzo riportato di seguito (è disponibile il file in formato stampabile) oppure contattare l'ufficio di rappresentanza locale della Yamaha. * EEA: Area Economica Europea</p>	Italiano
<p>Aviso importante: informações sobre as garantias para clientes da AEE* e da Suíça</p> <p>Para obter uma informação pormenorizada sobre este produto da Yamaha e sobre o serviço de garantia na AEE* e na Suíça, visite o site a seguir (o arquivo para impressão está disponível no nosso site) ou entre em contato com o escritório de representação da Yamaha no seu país. * AEE: Área Económica Europeia</p>	Português
<p>Σημαντική σημείωση: Πληροφορίες εγγύησης για τους πελάτες στον ΕΟΧ* και Ελλάδα</p> <p>Για λεπτομερείς πληροφορίες εγγύησης σχετικά με το παρόν προϊόν της Yamaha και την κάλυψη εγγύησης σε όλες τις χώρες του ΕΟΧ και την Ελλάδα, επισκεφτείτε την παρακάτω ιστοσελίδα (Εκτυπώσιμη μορφή είναι διαθέσιμη στην ιστοσελίδα μας) ή απευθυνθείτε στην αντιπροσωπεία της Yamaha στη χώρα σας. * ΕΟΧ: Ευρωπαϊκός Οικονομικός Χώρος</p>	Ελληνικά
<p>Viktigt: Garantiinformation för kunder i EES-området* och Schweiz</p> <p>För detaljerad information om denna Yamahaprodukt samt garantiservice i hela EES-området* och Schweiz kan du antingen besöka nedanstående webbadress (en utskriftsvänlig fil finns på webbplatsen) eller kontakta Yamahas officiella representant i ditt land. * EES: Europeiska Ekonomiska Samarbetsområdet</p>	Svenska
<p>Viktig merknad: Garantiinformasjon for kunder i EØS* og Sveits</p> <p>Detaljert garantiinformasjon om dette Yamaha-produktet og garantiservice for hele EØS-området* og Sveits kan fås enten ved å besøke nettstedene nedenfor (utskriftsversjon finnes på våre nettsider) eller kontakte kontakten Yamaha-kontoret i landet der du bor. *EØS: Det europeiske økonomiske samarbeidsområdet</p>	Norsk
<p>Vigtig oplysning: Garantioplysninger til kunder i EØO* og Schweiz</p> <p>De kan finde detaljerede garantioplysninger om dette Yamaha-produkt og den fælles garantiserviceordning for EØO* (og Schweiz) ved at besøge det websted, der er angivet nedenfor (der findes en fil, som kan udskrives, på vores websted), eller ved at kontakte Yamahas nationale repræsentationskontor i det land, hvor De bor. * EØO: Det Europæiske Økonomiske Område</p>	Dansk
<p>Tärkeä ilmoitus: Takuutiedot Euroopan talousalueen (ETA)* ja Sveitsin asiakkaille</p> <p>Tämän Yamaha-tuotteen sekä ETA-alueen ja Sveitsin takuuta koskevat yksityiskohtaiset tiedot saatte alla olevasta nettiosoitteesta. (Tulostettava tiedosto saatavissa sivustollamme.) Voitte myös ottaa yhteyttä paikalliseen Yamaha-edustajaan. *ETA: Euroopan talousalue</p>	Suomi
<p>Ważne: Warunki gwarancyjne obowiązujące w EOG* i Szwajcarii</p> <p>Aby dowiedzieć się więcej na temat warunków gwarancyjnych tego produktu firmy Yamaha i serwisu gwarancyjnego w całym EOG* i Szwajcarii, należy odwiedzić wskazaną poniżej stronę internetową (Plik gotowy do wydruku znajduje się na naszej stronie internetowej) lub skontaktować się z przedstawicielstwem firmy Yamaha w swoim kraju. * EOG — Europejski Obszar Gospodarczy</p>	Polski
<p>Důležité oznámení: Záruční informace pro zákazníky v EHS* a ve Švýcarsku</p> <p>Podrobné záruční informace o tomto produktu Yamaha a záručním servisu v celém EHS* a ve Švýcarsku naleznete na níže uvedené webové adrese (soubor k tisku je dostupný na našich webových stránkách) nebo se můžete obrátit na zastoupení firmy Yamaha ve své zemi. * EHS: Evropský hospodářský prostor</p>	Česky
<p>Fontos figyelemztetés: Garancia-információk az EGT* területén és Svájcban élő vásárlók számára</p> <p>A jelen Yamaha termékre vonatkozó részletes garancia-információk, valamint az EGT*-re és Svájcra kiterjedő garanciális szolgáltatás tekintetében keresse fel webhelyünket az alábbi címen (a webhelyen nyomtatható fájl is talál), vagy pedig lépjen kapcsolatba az országában működő Yamaha képviselői irodával. * EGT: Európai Gazdasági Térség</p>	Magyar
<p>Oluline märkus: Garantiiteave Euroopa Majanduspiirkonna (EMP)* ja Šveitsi klientidele</p> <p>Täpsema teabe saamiseks selle Yamaha toote garantii ning kogu Euroopa Majanduspiirkonna ja Šveitsi garantiiteeninduse kohta, külastage palun veebisaiti alljärgneval aadressil (meie saidil on saadaval printitav fail) või pöörduge Teie regiooni Yamaha esinduse poole. * EMP: Euroopa Majanduspiirkond</p>	Eesti keel
<p>Svarīgs paziņojums: garantijas informācija klientiem EEZ* un Šveicē</p> <p>Lai saņemtu detalizētu garantijas informāciju par šo Yamaha produktu, kā arī garantijas apkalpošanu EEZ* un Šveicē, lūdzu, apmeklējiet zemāk norādīto tīmekļa vietnes adresi (tīmekļa vietnē ir pieejams drukājams fails) vai sazinieties ar jūsu valsti apkalpojošo Yamaha pārstāvniecību. * EEZ: Eiropas Ekonomikas zona</p>	Latviešu
<p>Dėmesio: informacija dėl garantijos pirkėjams EEE* ir Šveicarijoje</p> <p>Jei reikia išsamios informacijos apie šį „Yamaha“ produktą ir jo techninę priežiūrą visoje EEE* ir Šveicarijoje, apsilankykite mūsų svetainėje toliau nurodytu adresu (svetainėje yra spausdintinas failas) arba kreipkitės į „Yamaha“ atstovybę savo šalyje. *EEE – Europos ekonominė erdvė</p>	Lietuvių kalba
<p>Dôležité upozornenie: Informácie o záruke pre zákazníkov v EHP* a Švajčiarsku</p> <p>Podrobné informácie o záruke týkajúce sa tohto produktu od spoločnosti Yamaha a garančnom servise v EHP* a Švajčiarsku nájdete na webovej stránke uvedenej nižšie (na našej webovej stránke je k dispozícii súbor na tlač) alebo sa obráťte na zástupcu spoločnosti Yamaha vo svojej krajine. * EHP: Európsky hospodársky priestor</p>	Slovenčina
<p>Pomembno obvestilo: Informacije o garanciji za kupce v EGP* in Švici</p> <p>Za podrobnejše informacije o tem Yamahinem izdelku ter garancijskem servisu v celotnem EGP in Švici, obiščite spletno mesto, ki je navedeno spodaj (natisljiva datoteka je na voljo na našem spletnem mestu), ali se obrnite na Yamahinega predstavnika v svoji državi. * EGP: Evropski gospodarski prostor</p>	Slovenščina
<p>Важно съобщение: Информация за гаранцията за клиенти в ЕИП* и Швейцария</p> <p>За подробна информация за гаранцията за този продукт на Yamaha и гаранционното обслужване в паневропейската зона на ЕИП* и Швейцария или посетете посочения по-долу уеб сайт (на нашия уеб сайт има файл за печат), или се свържете с представителния офис на Yamaha във вашата страна. * ЕИП: Европейско икономическо пространство</p>	Български език
<p>Notificare importantă: Informații despre garanție pentru clienții din SEE* și Elveția</p> <p>Pentru informații detaliate privind acest produs Yamaha și serviciul de garanție Pan-SEE* și Elveția, vizitați site-ul la adresa de mai jos (fișierul imprimabil este disponibil pe site-ul nostru) sau contactați biroul reprezentanței Yamaha din țara dumneavoastră. * SEE: Spațiul Economic European</p>	Limba română
<p>Važna obavijest: Informacije o jamstvu za države EGP-a i Švicarske</p> <p>Za detaljne informacije o jamstvu za ovaj Yamahin proizvod te jamstvenom servisu za cijeli EGP i Švicarsku, molimo Vas da posjetite web-stranicu navedenu u nastavku ili kontaktirate ovlaštenog Yamahinog dobavljača u svojoj zemlji. * EGP: Evropski gospodarski prostor</p>	Hrvatski

<https://europe.yamaha.com/warranty/>

Information for users on collection and disposal of old equipment:



This symbol on the products, packaging, and/or accompanying documents means that used electrical and electronic products should not be mixed with general household waste. For proper treatment, recovery and recycling of old products, please take them to applicable collection points, in accordance with your national legislation.

By disposing of these products correctly, you will help to save valuable resources and prevent any potential negative effects on human health and the environment which could otherwise arise from inappropriate waste handling.

For more information about collection and recycling of old products, please contact your local municipality, your waste disposal service or the point of sale where you purchased the items.

For business users in the European Union:

If you wish to discard electrical and electronic equipment, please contact your dealer or supplier for further information.

Information on Disposal in other Countries outside the European Union:

This symbol is only valid in the European Union. If you wish to discard these items, please contact your local authorities or dealer and ask for the correct method of disposal.

(weee_eu_en_02)

Verbraucherinformation zur Sammlung und Entsorgung alter Elektrogeräte



Befindet sich dieses Symbol auf den Produkten, der Verpackung und/oder beiliegenden Unterlagen, so sollten benutzte elektrische Geräte nicht mit dem normalen Haushaltsabfall entsorgt werden. In Übereinstimmung mit Ihren nationalen Bestimmungen bringen Sie alte Geräte bitte zur fachgerechten Entsorgung, Wiederaufbereitung und Wiederverwendung zu den entsprechenden Sammelstellen.

Durch die fachgerechte Entsorgung der Elektrogeräte helfen Sie, wertvolle Ressourcen zu schützen, und verhindern mögliche negative Auswirkungen auf die menschliche Gesundheit und die Umwelt, die andernfalls durch unsachgerechte Müllentsorgung auftreten könnten.

Für weitere Informationen zum Sammeln und Wiederaufbereiten alter Elektrogeräte kontaktieren Sie bitte Ihre örtliche Stadt- oder Gemeindeverwaltung, Ihren Abfallentsorgungsdienst oder die Verkaufsstelle der Artikel.

Information für geschäftliche Anwender in der Europäischen Union:

Wenn Sie Elektrogeräte ausrangieren möchten, kontaktieren Sie bitte Ihren Händler oder Zulieferer für weitere Informationen.

Entsorgungsinformation für Länder außerhalb der Europäischen Union:

Dieses Symbol gilt nur innerhalb der Europäischen Union. Wenn Sie solche Artikel ausrangieren möchten, kontaktieren Sie bitte Ihre örtlichen Behörden oder Ihren Händler und fragen Sie nach der sachgerechten Entsorgungsmethode.

(weee_eu_de_02)

Informations concernant la collecte et le traitement des déchets d'équipements électriques et électroniques



Le symbole sur les produits, l'emballage et/ou les documents joints signifie que les produits électriques ou électroniques usagés ne doivent pas être mélangés avec les déchets domestiques habituels. Pour un traitement, une récupération et un recyclage appropriés des déchets d'équipements électriques et électroniques, veuillez les déposer aux points de collecte prévus à cet effet, conformément à la réglementation nationale.

En vous débarrassant correctement des déchets d'équipements électriques et électroniques, vous contribuerez à la sauvegarde de précieuses ressources et à la prévention de potentiels effets négatifs sur la santé humaine qui pourraient advenir lors d'un traitement inapproprié des déchets.

Pour plus d'informations à propos de la collecte et du recyclage des déchets d'équipements électriques et électroniques, veuillez contacter votre municipalité, votre service de traitement des déchets ou le point de vente où vous avez acheté les produits.

Pour les professionnels dans l'Union européenne :

Si vous souhaitez vous débarrasser des déchets d'équipements électriques et électroniques, veuillez contacter votre vendeur ou fournisseur pour plus d'informations.

Informations sur la mise au rebut dans d'autres pays en dehors de l'Union européenne :

Ce symbole est seulement valable dans l'Union européenne. Si vous souhaitez vous débarrasser de déchets d'équipements électriques et électroniques, veuillez contacter les autorités locales ou votre fournisseur et demander la méthode de traitement appropriée.

(weee_eu_fr_02)

Información para usuarios sobre la recogida y eliminación de los equipos antiguos



Este símbolo en los productos, embalajes y documentos anexos significa que los productos eléctricos y electrónicos no deben mezclarse con los desperdicios domésticos normales.

Para el tratamiento, recuperación y reciclaje apropiados de los productos antiguos, llévelos a puntos de reciclaje correspondientes, de acuerdo con la legislación nacional.

Al deshacerse de estos productos de forma correcta, ayudará a ahorrar recursos valiosos y a impedir los posibles efectos desfavorables en la salud humana y en el entorno que de otro modo se producirían si se trataran los desperdicios de modo inapropiado.

Para obtener más información acerca de la recogida y el reciclaje de los productos antiguos, póngase en contacto con las autoridades locales, con el servicio de eliminación de basuras o con el punto de venta donde adquirió los artículos.

Para los usuarios empresariales de la Unión Europea:

Si desea desechar equipos eléctricos y electrónicos, póngase en contacto con su vendedor o proveedor para obtener más información.

Información sobre la eliminación en otros países fuera de la Unión Europea:

Este símbolo solo es válido en la Unión Europea. Si desea desechar estos artículos, póngase en contacto con las autoridades locales o con el vendedor y pregúnteles el método correcto.

(weee_eu_es_02)

Informações para os utilizadores relativas à recolha e eliminação de equipamentos usados



Este símbolo, presente em produtos, embalagens e/ou incluído na documentação associada, indica que os produtos elétricos e eletrónicos usados não devem ser eliminados juntamente com os resíduos domésticos em geral.

O procedimento correto consiste no tratamento, recuperação e reciclagem de produtos usados, pelo que deve proceder à respetiva entrega nos pontos de recolha adequados, em conformidade com a legislação nacional em vigor.

A eliminação destes produtos de forma adequada permite poupar recursos valiosos e evitar potenciais efeitos prejudiciais para a saúde pública e para o ambiente, associados ao processamento incorreto dos resíduos.

Para mais informações relativas à recolha e reciclagem de produtos usados, contacte as autoridades locais, o serviço de eliminação de resíduos ou o ponto de venda onde foram adquiridos os itens relevantes.

Informações para utilizadores empresariais na União Europeia:

Para proceder à eliminação de equipamento elétrico e eletrónico, contacte o seu revendedor ou fornecedor para obter informações adicionais.

Informações relativas à eliminação em países não pertencentes à União Europeia:

Este símbolo é válido exclusivamente na União Europeia. Caso pretenda eliminar este tipo de itens, contacte as autoridades locais ou o seu revendedor e informe-se acerca do procedimento correto para proceder à respetiva eliminação.

(weee_eu_pt_02a)

Informazioni per gli utenti sulla raccolta e lo smaltimento di vecchia attrezzatura



Questi simboli sui prodotti, sull'imballaggio e/o sui documenti che li accompagnano, indicano che i prodotti elettrici ed elettronici non devono essere mischiati con i rifiuti generici.

Per il trattamento, il recupero e il riciclaggio appropriato di vecchi prodotti, si prega di portarli ai punti di raccolta designati, in accordo con la legislazione locale.

Smaltendo correttamente questi prodotti si potranno recuperare risorse preziose, oltre a prevenire potenziali effetti negativi sulla salute e l'ambiente che potrebbero sorgere a causa del trattamento improprio dei rifiuti.

Per ulteriori informazioni sulla raccolta e il riciclaggio di vecchi prodotti, si prega di contattare l'amministrazione comunale locale, il servizio di smaltimento dei rifiuti o il punto vendita dove sono stati acquistati gli articoli.

Per utenti imprenditori dell'Unione europea:

Se si desidera scartare attrezzatura elettrica ed elettronica, si prega di contattare il proprio rivenditore o il proprio fornitore per ulteriori informazioni.

Informazioni sullo smaltimento negli altri Paesi al di fuori dell'Unione europea:

Questi simboli sono validi solamente nell'Unione Europea; se si desidera scartare questi articoli, si prega di contattare le autorità locali o il rivenditore e richiedere informazioni sulla corretta modalità di smaltimento.

(weee_eu_it_02)

ADDRESS LIST

NORTH AMERICA

CANADA

Yamaha Canada Music Ltd.
135 Milner Avenue, Toronto, Ontario, M1S 3R1, Canada
Tel: +1-416-298-1311

U.S.A.

Yamaha Corporation of America
6600 Orangethorpe Avenue, Buena Park, CA 90620,
U.S.A.
Tel: +1-714-522-9011

CENTRAL & SOUTH AMERICA

MEXICO

Yamaha de México, S.A. de C.V.
Av. Insurgentes Sur 1647 Piso 9, Col. San José
Insurgentes, Delegación Benito Juárez, México, D.F., C.P.
03900, México
Tel: +52-55-5804-0600

BRAZIL

Yamaha Musical do Brasil Ltda.
Praça Professor José Lannes, 40, Cjs 21 e 22, Brooklin
Paulista Novo CEP 04571-100 – São Paulo – SP, Brazil
Tel: +55-11-3704-1377

ARGENTINA

**Yamaha Music Latin America, S.A.,
Sucursal Argentina**
Olga Cossetini 1553, Piso 4 Norte,
Madero Este-C1107CEK,
Buenos Aires, Argentina
Tel: +54-11-4119-7000

PANAMA AND OTHER LATIN

AMERICAN/CARIBBEAN REGIONS

Yamaha Music Latin America, S.A.
Edif. Torre Banco General, Piso 7, Urbanización
Marbella, Calle 47 y Aquilino de la Guardia,
Ciudad de Panamá, República de Panamá
Tel: +507-269-5311

EUROPE

THE UNITED KINGDOM/IRELAND

Yamaha Music Europe GmbH (UK)
Sherbourne Drive, Tilbrook, Milton Keynes,
MK7 8BL, U.K.
Tel: +44-1908-366700

GERMANY

Yamaha Music Europe GmbH
Siemensstrasse 22-34, 25462 Rellingen, Germany
Tel: +49-4101-303-0

SWITZERLAND/LIECHTENSTEIN

**Yamaha Music Europe GmbH, Branch Switzerland in
Thalwil**
Seestrasse 18a, 8800 Thalwil, Switzerland
Tel: +41-44-3878080

AUSTRIA/BULGARIA/ CZECH REPUBLIC/HUNGARY/ ROMANIA/SLOVAKIA/SLOVENIA

**Yamaha Music Europe GmbH
Branch Austria**
Schleiergasse 20, 1100 Wien, Austria
Tel: +43-1-60203900

POLAND

**Yamaha Music Europe GmbH
Sp.z o.o. Oddział w Polsce**
ul. Wielicka 52, 02-657 Warszawa, Poland
Tel: +48-22-880-08-88

MALTA

Olimpus Music Ltd.
Valletta Road, Mosta MST9010, Malta
Tel: +356-2133-2093

NETHERLANDS/BELGIUM/LUXEMBOURG

Yamaha Music Europe Branch Benelux
Clarissenhof 5b, 4133 AB Vianen, The Netherlands
Tel: +31-347-358040

FRANCE

Yamaha Music Europe
7 rue Ambroise Croizat, Zone d'activités de Pariest,
77183 Croissy-Beaubourg, France
Tel: +33-1-6461-4000

ITALY

Yamaha Music Europe GmbH, Branch Italy
Via Tinelli N.67/69 20855 Gerno di Lesmo (MB), Italy
Tel: +39-039-9065-1

SPAIN/PORTUGAL

**Yamaha Music Europe GmbH Ibérica, Sucursal en
España**
Ctra. de la Coruña km. 17,200, 28231
Las Rozas de Madrid, Spain
Tel: +34-91-639-88-88

GREECE

Philippou Nakas S.A. The Music House
19th km. Leof. Lavriou 190 02 Peania – Attiki,
Greece
Tel: +30-210-6686168

SWEDEN/FINLAND/ICELAND

**Yamaha Music Europe GmbH Germany filial
Scandinavia**
JA Wettergrensgata 1, 400 43 Göteborg, Sweden
Tel: +46-31-89-34-00

DENMARK

**Yamaha Music Denmark,
Fillial of Yamaha Music Europe GmbH, Tyskland**
Generatorvej 8C, ST. TH., 2860 Søborg, Denmark
Tel: +45-44-92-49-00

NORWAY

**Yamaha Music Europe GmbH Germany -
Norwegian Branch**
Grini Næringspark 1, 1332 Østerås, Norway
Tel: +47-6716-7800

CYPRUS

Yamaha Music Europe GmbH
Siemensstrasse 22-34, 25462 Rellingen, Germany
Tel: +49-4101-303-0

RUSSIA

Yamaha Music (Russia) LLC.
Room 37, entrance 7, bld. 7, Kievskaya street, Moscow,
121059, Russia
Tel: +7-495-626-5005

OTHER EUROPEAN REGIONS

Yamaha Music Europe GmbH
Siemensstrasse 22-34, 25462 Rellingen, Germany
Tel: +49-4101-3030

AFRICA

Yamaha Music Gulf FZE
JAFZA-16, Office 512, P.O.Box 17328,
Jebel Ali FZE, Dubai, UAE
Tel: +971-4-801-1500

MIDDLE EAST

TURKEY

**Yamaha Music Europe GmbH
Merkezi Almanya Türkiye İstanbul Şubesi**
Mor Sumbul Sokak Varyap Meridian Business 1.Blok
No:1 113-114-115
Bati Atasehir Istanbul, Turkey
Tel: +90-216-275-7960

OTHER REGIONS

Yamaha Music Gulf FZE
JAFZA-16, Office 512, P.O.Box 17328,
Jebel Ali FZE, Dubai, UAE
Tel: +971-4-801-1500

ASIA

THE PEOPLE'S REPUBLIC OF CHINA

Yamaha Music & Electronics (China) Co.,Ltd.
2F, Yunhedasha, 1818 Xinzha-lu, Jingan-qu,
Shanghai, China
Tel: +86-400-051-7700

INDIA

Yamaha Music India Private Limited
P-401, JMD Megapolis, Sector-48, Sohna Road,
Gurugram-122018, Haryana, India
Tel: +91-124-485-3300

INDONESIA

PT Yamaha Musik Indonesia Distributor
Yamaha Music Center Bldg. Jalan Jend. Gatot Subroto
Kav. 4, Jakarta 12930, Indonesia
Tel: +62-21-520-2577

KOREA

Yamaha Music Korea Ltd.
11F, Prudential Tower, 298, Gangnam-daero,
Gangnam-gu, Seoul, 06253, Korea
Tel: +82-2-3467-3300

MALAYSIA

Yamaha Music (Malaysia) Sdn. Bhd.
No.8, Jalan Perbandaran, Kelana Jaya, 47301
Petaling Jaya, Selangor, Malaysia
Tel: +60-3-78030900

SINGAPORE

Yamaha Music (Asia) Private Limited
Block 202 Hougang Street 21, #02-00,
Singapore 530202, Singapore
Tel: +65-6740-9200

TAIWAN

Yamaha Music & Electronics Taiwan Co.,Ltd.
2F., No.1, Yuandong Rd., Banqiao Dist.,
New Taipei City 22063, Taiwan (R.O.C.)
Tel: +886-2-7741-8888

THAILAND

Siam Music Yamaha Co., Ltd.
3, 4, 15, 16th Fl., Siam Motors Building,
891/1 Rama 1 Road, Wangmai,
Pathumwan, Bangkok 10330, Thailand
Tel: +66-215-2622

VIETNAM

Yamaha Music Vietnam Company Limited
15th Floor, Nam A Bank Tower, 201-203 Cach Mang
Thang Tam St., Ward 4, Dist.3,
Ho Chi Minh City, Vietnam
Tel: +84-8-3818-1122

OTHER ASIAN REGIONS

<http://asia.yamaha.com/>

OCEANIA

AUSTRALIA

Yamaha Music Australia Pty. Ltd.
Level 1, 80 Market Street, South Melbourne,
VIC 3205, Australia
Tel: +61-3-9693-5111

REGIONS AND TRUST TERRITORIES IN PACIFIC OCEAN

<http://asia.yamaha.com/>

PA57

Head Office/Manufacturer: Yamaha Corporation 10-1, Nakazawa-cho, Naka-ku, Hamamatsu, 430-8650, Japan
(For European Union) Importer: Yamaha Music Europe GmbH Siemensstrasse 22-34, 25462 Rellingen, Germany
(For United Kingdom) Importer: Yamaha Music Europe GmbH (UK) Sherbourne Drive, Tilbrook, Milton Keynes, MK7 8BL, United Kingdom

雅马哈乐器音响(中国)投资有限公司

上海市静安区新闻路 1818 号云和大厦 2 楼

客户服务热线: 4000517700

公司网址: <https://www.yamaha.com.cn>

制造商: 雅马哈株式会社

制造商地址: 日本静冈县滨松市中区中泽町 10-1

进口商: 雅马哈乐器音响(中国)投资有限公司

进口商地址: 上海市静安区新闻路 1818 号云和大厦 2 楼

原产地: 印度

Yamaha Pro Audio global website
<http://www.yamahaproaudio.com/>

Yamaha Downloads
<https://download.yamaha.com/>

Manual Development Group
© 2021 Yamaha Corporation
Published 04/2021
2021年4月发行
POIN - A1

VDK0300