



Questo manuale d'istruzione è fornito da trovaprezzi.it. Scopri tutte le offerte per [Zebra MP7000](#) o cerca il tuo prodotto tra le [migliori offerte di Palmari e Barcode Scanner](#)



Questo manuale d'istruzione è fornito da trovaprezzi.it. Scopri tutte le offerte per [Zebra MP7000](#) o cerca il tuo prodotto tra le [migliori offerte di Palmari e Barcode Scanner](#)



MP7000

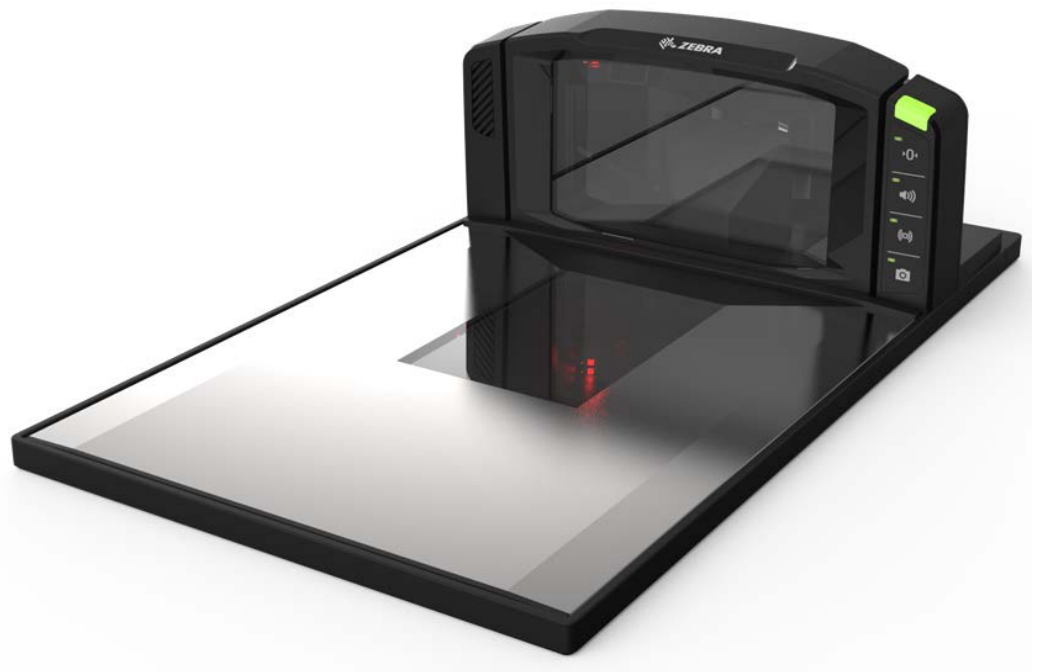

Scanner Scale

Integrator Guide



MP7000 SCANNER SCALE INTEGRATOR GUIDE

MN-002914-10EN

Revision A

June 2023

Revision History

Changes to the original guide are listed below:

Change	Date	Description
-10EN Rev. A	June 2023	Updated Note on: - Supported Auxiliary Hand-Held Scanner - Auxiliary Ports and Peripherals
-09EN Rev. A	October 2022	Added Single Head Pole Display and Dual Head Pole Display configurations.
-08EN Rev. A	February 2021	Updated "Identifying Firmware Version" instructions.
-07EN Rev. A	December 2020	Removed reference of slave in Host Interfaces chapter.
-06EN Rev. A	June 2020	Added color camera installation and specifications.
-05 Rev. A	December 2019	Updated: - Copyright statement - Parameter #1246 - Table 2-8 (Terminal Specific Code ID Characters)
-04 Rev. A	February 2018	Updated Scale Pole Display Type parameters.
-03 Rev. A	August 2017	Updated Sensormatic information.
-02 Rev. A	July 2017	Updates/Adds: - Feedback URL - MP7012 configurations - MX101 PRG to Related Documents - Changed 90 second timeout to 30 second timeout (scale calibration) - Updated locations of AUX 1 & 2 ports - Changed height of units above platter - Horizontal Checkpoint Antenna parts - Vertical Checkpoint Antenna parts
-01 Rev. A	June 2017	Initial Release.

TABLE OF CONTENTS

Revision History	ii
------------------------	----

About This Guide

Introduction	v
Related Documents and Software	v
Chapter Descriptions	v
Notational Conventions	vi
Zebra OneCare Support Services for the MP7000	vii
Features for All Service Levels and All Products	vii
Global Support	vii
Online Access to Software Updates	vii
Support Help Desk	vii
Comprehensive Coverage	vii
Online RMA	vii
Additional Features for OneCare Select Service Only	vii
Advanced Exchange	vii
Spares Pool Management	vii
24/7/365 Telephone Support	viii
Service Dashboard (Optional in Essential)	viii
On-site System Support	ix
Service Authorization	ix
Technical Support and Software	x
Summary	x

Chapter 1: Product Overview and Features

Introduction	1-1
Product Overview	1-2
Configurations	1-3
Peripherals	1-8
Supported Auxiliary Hand-held Scanner	1-8
EAS Devices	1-8
Scale Devices	1-8

USB Flash Drives	1-8
Customer Side Scanner (CSS)	1-8
Related Product Line Configurations	1-8
Features of the MP7000 Scanner Scale	1-9
Scale Displays (Some Scanner/Scale Configurations Only)	1-12
Flip Up Produce Bar (Standard on all Scale Models)	1-15
Features Summary	1-15

Chapter 2: Host Interfaces and Cable Pinouts

Introduction	2-1
Interfaces, Components, and Communication	2-1
POS Interfaces and Host Communication	2-1
Auxiliary Ports and Peripherals	2-2
Programming Management Tools	2-2
Application Programming Interfaces	2-2
USB Interface	2-3
Connecting	2-3
USB Host Parameters	2-4
USB Device Type	2-4
RS-232 Interface	2-12
Connecting	2-12
MP7000 Scanner Only or MP7200/7500 Scale with Single Cable Protocol	2-12
Price Computational Scale Interface Circuit Drawing	2-14
Connecting to an RS-232 Host	2-14
Models with a Dual Cable Scanner/Scale	2-14
RS-232 Parameters	2-16
RS-232 Host Parameters	2-17
RS-232 Terminal Specific Parameters	2-17
RS-232 Terminal Specific Code ID Characters	2-19
RS-232 Host Types	2-21
RS-232 Host -NCR Variant	2-31
RS-232 Host -Datalogic Variant	2-32
RS-232 Device Port Configuration	2-33
Third Party Scale Parameters	2-46
Third Party Scale	2-46
Third Party Scale LED Pin	2-48
Third Party Scale Zero Pin	2-50
IBM RS-485 Interface	2-52
Connecting	2-52
IBM RS-485 Host Parameters	2-53
IBM Port Addresses	2-54
IBM Port Addresses (continued)	2-57
IBM Scale Port Addresses	2-58
Connector Pins	2-62
RS-232 AUX 1	2-62
Scale Display Port	2-62
RS-232 AUX 2	2-63
Checkpoint Interlock	2-63
AUX A-B (Stacked USB)	2-64

POS	2-64
12V DC	2-65
Chapter 3: Site Preparation and Installation	
Introduction	3-1
Site Preparation	3-2
Ventilation and Spacing Requirements	3-2
Service Access Requirements	3-2
Electrical Power Considerations	3-3
Grounding	3-3
Checkstand Preparation	3-4
Liquid Spills and Moisture	3-4
Vertical Clearance	3-4
Tools	3-4
Counter Cutout	3-5
Ergonomics	3-5
Installing Components	3-5
Quick Reference Installation Steps	3-5
Remove Existing Scanner Scale and Accessories	3-6
Unpacking MP7000 Scanner Scale Equipment	3-6
Pre-Installation Notes	3-7
Install the Scale Display	3-8
Getting Started	3-10
Installing	3-11
Cables and Connections	3-11
Install the MX101	3-12
Install the MP7000 Scanner Scale	3-12
Checkstand Counter Cutouts and MP70XX Dimensions	3-12
Cutout/Dimensions - MP70XX Short	3-13
Cutout/Dimensions - MP70XX Medium	3-15
Cutout/Dimensions - MP70XX Long	3-17
Install the Sensormatic Coil Antenna	3-21
Install the Checkpoint Antennas	3-23
Horizontal Checkpoint Antenna	3-23
Vertical Checkpoint Antenna	3-24
Trim Kit Installation (If Required)	3-30
Chapter 4: Scale Calibration (For Models With a Scale)	
Introduction	4-1
Scale Calibration Procedure (Scanner/Scale Configurations Only)	4-2
Scale Configurations	4-2
Step 1 - Electronic Entry into Calibration Mode	4-3
Step 2 - Manual Entry into Calibration Mode	4-3
Step 3 - Program Legal Parameters	4-4
Legal Scale Units (Unit Selection) - Kilograms or Pounds	4-4
Important Notes	4-4
Legal Scale Dampening Filter	4-5
Step 4 - Calibration at NO LOAD	4-5

Step 5 - Calibration at LOAD	4-5
Step 6 - Calibration Success or Failure	4-7
Calibration Success	4-7
Calibration Failure	4-8
Possible Reasons for a Fail	4-8
Calibration Mode Exit Conditions	4-8
Verification Test	4-8
Audit Tallies	4-12
Scale Configuration Parameters	4-13
Legal Scale Units	4-13
Scale Display Configuration	4-15
Legal Scale Dampening Filter Setting	4-17
Scale Pole Display Type	4-21
User Interface Displays and Signals	4-23

Chapter 5: Operating the Scanner

Introduction	5-1
Controls and Indicators	5-1
LED	5-1
Diagnostic LED/7-segment Display	5-2
Front Panel Buttons	5-3
Scale Zero Button (Configurations with Scale Only)	5-3
Volume/Tone Control Button	5-3
Sensormatic Manual Activation and Sensormatic Status Button	5-4
Camera Activation Button	5-4
To Capture an Image	5-4
To Scan a Bank Check	5-4
Soft Reset Buttons	5-4
Identifying Firmware Version	5-4
MP7000 Scanner Scale Related Hardware	5-5
Scale Display (Scanner/Scale Configurations Only)	5-5
Scale (Scanner/Scale Configurations Only)	5-5
Single Interval Range Scales	5-5
Dual Interval Range Scales	5-5
Calibration Switch	5-5
CSS - Optional	5-5
Platter	5-6
Removing the Short or Medium Platter	5-6
Installing the Short or Medium Platter	5-7
Removing the Long Platter	5-7
Installing the Long Platter	5-8
Scan Windows	5-8
Operating Modes	5-8
Programming the MP70XX	5-9
Programming Management Tools	5-9
Application Programming Interfaces	5-9
Programming Barcodes	5-9
USB Staging Flash Drive	5-10
MP70XX Menu Structure for the USB Staging Flash Drive	5-10

Manually Staging/Configuring MP70XX Devices	5-11
Loading Cloning Files	5-12
123Scan Staging Flash Drive Configuration	5-13
Approved USB Flash Drives for the Flash Drive Well	5-13
Scanning	5-14
Weighing Items	5-14
Electronic Article Surveillance (EAS)	5-15
Supported EAS Controllers	5-15
EAS Operating Modes and Settings	5-16
Checkpoint Controller	5-16
Sensormatic Controller	5-17
Sensormatic EAS Hard Tags	5-17
Sensormatic EAS Soft Tags (Labels)	5-17
Beeper and LED Conditions	5-18
Chapter 6: Color Camera Installation and Use	
Introduction	6-1
Color Camera Kit	6-1
Kit Parts	6-2
Installing the Color Camera	6-3
MP7000 Inner Housing	6-3
Color Camera Uses	6-6
Chapter 7: 123Scan and Software Tools	
Introduction	7-1
123Scan	7-1
Communication with 123Scan	7-2
123Scan Requirements	7-2
123Scan Information	7-3
Scanner SDK, Other Software Tools, and Videos	7-3
Advanced Data Formatting (ADF)	7-4
Appendix A: Maintenance, Troubleshooting, and Error Codes	
Introduction	A-1
Maintenance	A-1
Diagnostic LED 7-segment Display - Error and Warning Codes	A-2
LED Display Notes	A-2
Status Indicator Light	A-2
Troubleshooting Assistance	A-3
General Error and Warning Codes	A-4
Scale Warning Codes	A-6

Appendix B: Technical Specifications

Appendix C: ASCII Character Sets

Appendix D: Standard Parameter Defaults

Appendix E: Communication Protocol Functionality

Functionality Supported via Communication (Cable) Interface E-1

Appendix F: Statistics

MP7 Statistics Definitions F-1

- Time and Usage F-1
- Last Scanned Barcode F-1
- Decode Time and Count F-1
- Communication Diagnostics F-3
- Illumination Diagnostics F-3
- Sensor/Camera Diagnostics F-4
- Scale Diagnostics F-5
- EAS Diagnostics F-6
- Object Detection Diagnostics F-6
- Other Diagnostics F-6

Index

ABOUT THIS GUIDE

Introduction

This guide provides information about installing, operating, and programming the MP7000 Scanner Scale.

✓ **NOTE** Screens and windows pictured in this guide are samples and can differ from actual screens.

Related Documents and Software

The documentation set for the device is divided into guides that provide information for specific user needs.

- *MP7000 Scanner Scale Barcode Programming Guide*, p/n MN-002912-xx, provides barcodes for device configuration.
- *MP7000 Scanner Scale Regulatory Guide*, p/n MN-002939-xx, provides domestic and international regulatory information.
- *MX101 Customer Side Scanner Product Reference Guide*, p/n MN-003031-xx, provides barcodes for MX101 device configuration.
- *Advanced Data Formatting Programmer Guide*, p/n 72E-69680-xx, provides information on ADF, a means of customizing data before transmission to a host.

For the latest version of this guide and all guides, go to: zebra.com/support.

Chapter Descriptions

Topics covered in this guide are as follows:

- [Chapter 1, Product Overview and Features](#) provides an overview of the MP7000 Scanner Scale including configurations, peripherals, and features.
- [Chapter 2, Host Interfaces and Cable Pinouts](#) describes the host interfaces supported by the MP7000 Scanner Scale, how to connect to a host, setup, and cable pin-outs. It also includes host interface barcodes.

- [Chapter 3, Site Preparation and Installation](#) describes how to install the MP7000 Scanner Scale into a counter top.
- [Chapter 4, Scale Calibration \(For Models With a Scale\)](#) describes how to change weight measurement, calibrate the scale, verify calibration, and recognize errors.
- [Chapter 5, Operating the Scanner](#) describes how to operate the MP7000 Scanner Scale including buttons, switches, LED indicators, and scanning.
- [Chapter 6, Color Camera Installation and Use](#) describes how to install the color camera and it uses.
- [Chapter 7, 123Scan and Software Tools](#) provides information about configuring the MP7000 Scanner Scale using the 123Scan utility.
- [Appendix A, Maintenance, Troubleshooting, and Error Codes](#) provides error/warning codes, troubleshooting, and maintenance information.
- [Appendix B, Technical Specifications](#) provides technical information about the MP7000 Scanner Scale.
- [Appendix C, ASCII Character Sets](#) provides ASCII character sets for some host interfaces.
- [Appendix D, Standard Parameter Defaults](#) provides a list of defaults for the parameters in this guide. For all MP7000 Scanner Scale programming barcodes, refer to the *MP7000 Scanner Scale Barcode Programming Guide* (p/n MN-002912-xx).
- [Appendix E, Communication Protocol Functionality](#) provides a table of MP7000 Scanner Scale communication interfaces.
- [Appendix F, Statistics](#) provides a table of MP7000 Scanner Scale attribute statistics.

Notational Conventions

The following conventions are used in this document:

- *Italics* are used to highlight the following:
 - Chapters and sections in this guide
 - Related documents
- **Bold** text is used to highlight the following:
 - Dialog box, window and screen names
 - Drop-down list and list box names
 - Check box and radio button names
 - Icons on a screen
 - Key names on a keypad
 - Button names on a screen.
- Bullets (•) indicate:
 - Action items
 - Lists of alternatives
 - Lists of required steps that are not necessarily sequential.
- Sequential lists (e.g., those that describe step-by-step procedures) appear as numbered lists.

Zebra OneCare Support Services for the MP7000

Zebra's Support Services include a complete portfolio of repair programs that offer an integrated support solution that encompasses telephone support, software support, web self-service, and service center repair - all backed by a global support infrastructure and proven expertise.

Zebra OneCare offers two levels of support on the MP7000 products; Zebra OneCare Essential and Zebra OneCare Select. Each level provides different features and deliverables designed to meet customer requirements.

Features for All Service Levels and All Products

Global Support

With support for 16 languages and repair centers around the globe, we're ready to take care of your customers' service needs, no matter where in the world they are located.

Online Access to Software Updates

All OneCare customers can download the updates as many times as desired via Zebra's 123Scan2 utility.

Support Help Desk

Zebra's help desk of technical professionals is open 24/7/365 to customers with select service contracts, Seamless integration with Zebra's services helps ensure ongoing support for your customer's products. Our experienced support engineers are available to assist customers with problem diagnosis and resolution - helping to ensure that the systems they rely on to keep business critical functions running smoothly are available and running at peak performance. Essential customers get coverage during business hours. Customers may log cases night and day - especially useful to retailers and logistics companies whose doors never close - and whose workers continuously utilize their Zebra products.

Comprehensive Coverage

Comprehensive Coverage. No matter what breaks, we fix it, no questions asked - from displays to housings.

Online RMA

Online RMA makes device return easier than ever. Customers can access the website to schedule a device return any time of the day or night.

Additional Features for OneCare Select Service Only

Advanced Exchange

With Advanced Exchange, no matter what is wrong, when you or your customer reports a malfunctioning device, we ship a replacement device the same day for next-business day replacement. The result? Minimal downtime for malfunctioning devices, protecting productivity and return on investment.

Spares Pool Management

We maintain an inventory of the same devices your customer is utilizing. When a device requires a trip to the service depot, we simply ship a replacement device from a pool to your customer. As devices are repaired, they are returned to the pool.

24/7/365 Telephone Support

After hours Level 1 support is always available for Zebra OneCare Select customers. Fully trained help desk representatives with the skill set required to isolate, analyze and resolve issues will perform Level 1 Triage to determine the best course of action. If help desk representatives are unable to resolve an issue, it is escalated to Level 2 staff, who will respond during normal business hours. Partner value: If you are delivering the service, you get the around-the-clock support you need to provide your customer with the best response times. Customer value: Your customer gets the peace of mind that no matter when their device malfunctions, they can reach a technician.

Service Dashboard (Optional in Essential)

The Service Dashboard is a portal that provides visibility into the status of all devices in the repair cycle. With the Select Dashboard, your customers can view the status of all open help desk cases; the condition of all their Zebra devices at all sites, per site, per specific model; and the status of a specific individual device. Thresholds and date ranges are customizable, allowing your customers to define what information is presented on the dashboard, such as the number of resolutions completed. With both the Essential and Select dashboards, customers may track repairs by serial number and the ratio of 'no trouble found' to repair resolutions. Customers can view the number of devices, the number of devices due back to the depot and the number of devices currently received by the depot and in repair. Select customers may check on the number of available spares in the pool. The Service Dashboard is optional in the Essential service, standard in the Select service. Partner value: If your partners are delivering the service, they can use the dashboard to reduce the time and cost associated with managing and monitoring devices that are in the repair cycle. they can also offer their customers a version of the dashboard, complete with their own logo, providing an extra value to your customer while promoting your brand. Customer value: Your customers can heavily automate the management of devices in the repair cycle - no more time spent tracking devices and preparing reports, driving down the cost of repair management.

Service Center support services are also available for customers who do not purchase service within 30 days of purchasing the product. High level deliverables are shown below.

For customers not wishing to have hardware coverage and TTP partners (see below), Software Support Services (SWSS) are also available providing access to software releases and technical support.

A snapshot of the support services and part numbers are shown below.

Coverage Type	Availability	Coverage	Description	# of Years Covered
Zebra OneCare Essential with Comprehensive Coverage	Available up to 30 days from point of sale.	Covers repair that is required due to functional failure, normal wear and tear, and accidental damage. Includes technical support, software releases, and return shipping. Services Dashboard is also included and the in Select (option in Essential - OPT-Dashboard-XX).	Repair: Three days from day of receipt in Zebra repair center; Technical Support response four hours from inquiry.	3 years
				5 years
Zebra OneCare Select with Comprehensive Coverage			Replacement shipped on day of request; Technical Support response four hours from inquiry.	2 year renewal
				3 years
			5 years	
				2 year renewal

Coverage Type	Availability	Coverage	Description	# of Years Covered
Service Center Essential	Any time up to product End of Life.	Covers repair that is required due to functional failure, and normal wear and tear. Includes technical support, device diagnostics, software releases, and return shipping.	Repair: Three days from day or receipt in Zebra repair center; Technical Support response four hours from inquiry.	3 years
				5 years
Service Center Select			Replacement shipped on day of request; Technical Support response four hours from inquiry.	3 years
				5 years
Technical Support & Software (TSS)	Any time up to product End of Life.	Software and technical support, and software releases for MP7xxx devices. Price is per device.	Technical Support response: 4 hours from inquiry.	1 year
				3 years
				5 years

On-site System Support

Zebra's On Site System Support delivers peace of mind with the services your customers need, ensuring rapid problem resolution and a fast return to full operable status with a range of options to fit their business needs. On Site System Support is designed to provide an immediate response with minimum effort. Initiate on-site service with a single phone call; a Zebra support specialist will offer quick problem determination and resolution. This is only available in Certain Geographies check with your local services representative before offering.

Service Name	Service Description	Time Of Purchase	Length Of Coverage
Service from the Start On-site System Support	Fast response time: Field Service Representative responds on site next business day.	Up front with the hardware (prepaid) or within 30 days thereafter.	Three years Five years
On-site System Support	Includes Comprehensive Coverage. Full access to technical support resources. Rights to download and use software releases and supporting documentation.	Any time	One year

Service Authorization

Zebra has a service authorization program covering bioptic products, this allows qualified companies (such as partners) to be trained and have access to spare parts allowing them to affect on-site repairs. This is a restricted program and subject to strict entry criteria.

Within the retail environment it is well known that large retailers generally outsource maintenance and support for all their POS equipment to one provider. When dealing with products such as the MP7000, these maintenance providers have the necessary skills and tools to be able to repair units either in the field or at their own workshops using Spare parts available under the Service Authorization program

Technical Support and Software

This service provides access to Zebra technical support resources during Business hours who will provide a 4 hour response to problems raised. Additionally this service provides entitlement to access, deploy and use the latest software releases for the MP7000 product.

Summary

The table below provides a summary of the standard support services available for the MP7000 products.

	Zebra OneCare Essential	Zebra OneCare Select
Term	3 or 5 Years	3 or 5 Years
Repair Turnaround Time	3 Business Days from Depot Receipt	Replacement Shipped on Day of Request
Support Help Desk	8 x 5	24 x 7
Comprehensive Coverage	✓	✓
Buffer Stock Setup and Management	N/A	✓
Responsibility for Placing MP7000 Into Trade	Purchaser	Purchaser
Overnight Shipping	Option	Option
Online Repair Services Dashboard	Option	Included

On-site Support Limited Geographies	<ul style="list-style-type: none"> • Fast response time. Field Services Representative responds on-site next business day. • Include comprehensive coverage. • Full access to technical support resources. • Rights to download and use software releases and supporting documentation.
TSS	<ul style="list-style-type: none"> • Full access to technical support resources. • Rights to download and use software releases and supporting documentation.

CHAPTER 1 PRODUCT OVERVIEW AND FEATURES

Introduction

This chapter includes the following topics:

- *Product Overview on page 1-2*
- *Configurations on page 1-3*
- *Peripherals on page 1-8*
- *Features of the MP7000 Scanner Scale on page 1-9.*

Product Overview

The MP7000 Scanner Scale is a data capture solution that reads 1D, 2D and mobile barcodes in all orientations. Barcode data is transmitted to a Point-Of-Sale (POS) host via USB, RS-232, or RS-485. Auxiliary device support includes USB and RS-232 hand-held scanners, Checkpoint and Sensormatic Electronic Article Surveillance (EAS), scale and optional Scale Display (varies with the model), USB staging flash drive (memory stick), as well as an optional Customer Side Scanner (2D imager) that may be mounted into the tower. In addition the scanner has the ability to read Digimarc barcodes.

The MP70XX is designed to be embedded in a cutout in the retail checkstand.

Features include:

- Reading 1D, 2D (PDF, Aztec etc.) and mobile barcodes (cell phone) in all orientations
 - Reads top-bottom, left-right, and cashier-customer side barcodes
 - Omni-directional symbol orientation.
- Optional integrated scale (single/dual interval).
- Optional Checkpoint EAS antenna.
- Support for low inductance Sensormatic EAS coil.
- Optional Scale Display (single/dual head) for scale installations.
- Auxiliary scanner support (USB and RS-232).
- High swipe speed for increased throughput.
- User interface (LED indicators, touch controls, audio).
- Aggressive scanning performance on high density, truncated, and poorly printed barcodes.
- Optional integrated Customer Side Scanner (CSS) - 1D/2D support.
- Scanner Management Service (SMS), and 123Scan support enables remote configuration and monitoring attached peripherals.

Configurations

The MP7000 Scanner Scale captures printed or mobile 1D or 2D barcodes. An optional customer-side scanner (CSS) can be added for barcodes displayed on mobile phones, traditional loyalty cards, or item barcodes. \

Hand-held scanner, integrated EAS, and scale support is also available.

This guide covers the configurations listed in [Table 1-1](#).

- ✓ **NOTE**
1. All scale models include a flip up produce bar.
 2. New scale configurations are added continually. If you don't see your country listed, call your Zebra office.

Table 1-1 MP7000 Scanner Scale Configurations

Configuration	Description
MP7000 Scanner Only	
MP7000-SNS0M00WW	MP7000 Scanner only, Short, Sapphire, WW
MP7000-MNS0M00WW	MP7000 Scanner only, Medium, Sapphire, WW
MP7000-LNS0M00WW	MP7000 Scanner only, Long, Sapphire, WW
MP7000-SPS0M00WW	MP7000 Scanner only, Short, Sapphire, Drivers License Parsing, WW
MP7000-MPS0M00WW	MP7000 Scanner only, Medium, Sapphire, Drivers License Parsing, WW
MP7000-LPS0M00WW	MP7000 Scanner only, Long, Sapphire, Drivers License Parsing, WW
MP7000 Scanner Scale	
MP7001-LNSLM00US	MP7001 Scanner Scale, Long, Single Interval Scale, Sapphire, United States
MP7001-LPSLM00US	MP7001 Scanner Scale, Long, Single Interval Scale, Sapphire, Drivers License Parsing, United States
MP7001-LNSLM00CM	MP7001 Scanner Scale, Long, Single Interval Scale, Sapphire, Canada/Mexico
MP7001-LNSLM00EU	MP7001 Scanner Scale, Long, Single Interval Scale, Sapphire, Europe
MP7001-LNSLM00AU	MP7001 Scanner Scale, Long, Single Interval Scale, Sapphire, Australia
MP7001-LNSLM00NN	MP7001 Scanner Scale, Long, Single Interval Scale, Sapphire, OIML
MP7001-LNSLM00CN	MP7001 Scanner Scale, Long, Single Interval Scale, Sapphire, China

Notes:

1. EU scales are legally accepted in the following countries: Austria, Belgium, Bulgaria, Croatia, Cyprus, Czech Republic, Denmark, Estonia, Finland, France, Germany, Greece, Hungary, Ireland, Iceland, Italy, Liechtenstein, Lithuania, Luxembourg, Latvia, Malta, Netherlands, Norway, Poland, Portugal, Romania, Slovak Republic, Slovenia, Spain, Sweden, Switzerland, and United Kingdom
2. OIML scales are legally accepted in the following countries: Bahamas, Barbados, Belize, Bermuda, Chile, Colombia, Costa Rica, Ecuador, El Salvador, Guatemala, Hong Kong, Jamaica, Saint Lucia, Panama, Peru, Philippines, Thailand, Trinidad, and Tobago
3. The color camera configuration type (portrait or landscape) is noted by the fifth digit after the dash. For example, MP7001-MNSLX00EU includes a P (Portrait camera orientation) or C (Landscape camera orientation).

Table 1-1 MP7000 Scanner Scale Configurations (Continued)

Configuration	Description
MP7001-LNSLM00RU	MP7001 Scanner Scale, Long, Single Interval Scale, Sapphire, Russia
MP7001-LNSLM00DO	MP7001 Scanner Scale, Long, Single Interval Scale, Sapphire, Dominican Republic
MP7001-MNSLM00US	MP7001 Scanner Scale, Medium, Single Interval Scale, Sapphire, United States
MP7001-MPSLM00US	MP7001 Scanner Scale, Medium, Single Interval Scale, Sapphire, Drivers License Parsing, United States
MP7001-MNSLM00CM	MP7001 Scanner Scale, Medium, Single Interval Scale, Sapphire, Canada/Mexico
MP7001-MNSLM00EU	MP7001 Scanner Scale, Medium, Single Interval Scale, Sapphire, Europe
MP7001-MNSLM00AU	MP7001 Scanner Scale, Medium, Single Interval Scale, Sapphire, Australia
MP7001-MNSLM00NN	MP7001 Scanner Scale, Medium, Single Interval Scale, Sapphire, OIML
MP7001-MNSLM00CN	MP7001 Scanner Scale, Medium, Single Interval Scale, Sapphire, China
MP7001-MNSLM00RU	MP7001 Scanner Scale, Medium, Single Interval Scale, Sapphire, Russia
MP7001-MNSLM00DO	MP7001 Scanner Scale, Medium, Single Interval Scale, Sapphire, Dominican Republic
MP7002-LNSLM00EU	MP7002 Scanner Scale, Long, Dual Interval Scale, Sapphire, Europe
MP7002-LNSLM00AU	MP7002 Scanner Scale, Long, Dual Interval Scale, Sapphire, Australia
MP7002-LNSLM00NN	MP7002 Scanner Scale, Long, Dual Interval Scale, Sapphire, OIML
MP7002-MNSLM00EU	MP7002 Scanner Scale, Medium, Dual Interval Scale, Sapphire, Europe
MP7002-MNSLM00AU	MP7002 Scanner Scale, Medium, Dual Interval Scale, Sapphire, Australia
MP7002-MNSLM00NN	MP7002 Scanner Scale, Medium, Dual Interval Scale, Sapphire, OIML
MP7000 Scanner Only with CSS	
MP7010-LNS0M00WW	MP7010 Scanner, Long, Sapphire, CSS, Worldwide
MP7010-LPS0M00WW	MP7010 Scanner, Long, Sapphire, CSS, Drivers License Parsing, United States
MP7010-MNS0M00WW	MP7010 Scanner, Medium, Sapphire, CSS, Worldwide

Notes:

- EU scales are legally accepted in the following countries: Austria, Belgium, Bulgaria, Croatia, Cyprus, Czech Republic, Denmark, Estonia, Finland, France, Germany, Greece, Hungary, Ireland, Iceland, Italy, Liechtenstein, Lithuania, Luxembourg, Latvia, Malta, Netherlands, Norway, Poland, Portugal, Romania, Slovak Republic, Slovenia, Spain, Sweden, Switzerland, and United Kingdom
- OIML scales are legally accepted in the following countries: Bahamas, Barbados, Belize, Bermuda, Chile, Colombia, Costa Rica, Ecuador, El Salvador, Guatemala, Hong Kong, Jamaica, Saint Lucia, Panama, Peru, Philippines, Thailand, Trinidad, and Tobago
- The color camera configuration type (portrait or landscape) is noted by the fifth digit after the dash. For example, MP7001-MNSLX00EU includes a P (Portrait camera orientation) or C (Landscape camera orientation).

Table 1-1 MP7000 Scanner Scale Configurations (Continued)

Configuration	Description
MP7010-MPS0M00WW	MP7010 Scanner, Medium, Sapphire, CSS, Drivers License Parsing, United States
MP7010-SNS0M00WW	MP7010 Scanner, Short, Sapphire, CSS, Worldwide
MP7010-SPS0M00WW	MP7010 Scanner, Short, Sapphire, CSS, Drivers License Parsing, Worldwide
MP7010-MNSLM00WW	MP7010 Scanner, Medium, Flip Bar Platter, CSS, Third Party Scale Support, United States
MP7000 Scanner Scale with CSS	
MP7011-LNS0M00US	MP7011 Scanner Scale, Long, Single Interval Scale, Sapphire, CSS, Platter without Flip Up Bar, United States
MP7011-LNSLM00AU	MP7011 Scanner Scale, Long, Single Interval Scale, Sapphire, Platter with Flip Up Bar, CSS, Australia
MP7011-LNSLM00CM	MP7011 Scanner Scale, Long, Single Interval Scale, Sapphire, Platter with Flip Up Bar, Canada/Mexico
MP7011-LNSLM00US	MP7011 Scanner Scale, Long, Single Interval Scale, Sapphire, CSS, Platter with Flip Up Bar, United States
MP7011-LPSLM00US	MP7011 Scanner Scale, Long, Single Interval Scale, Sapphire, CSS, Drivers License Parsing, Platter with Flip Up Bar, United States
MP7011-LNSLM00NN	MP7011 Scanner Scale, Long, Single Interval Scale, Sapphire, CSS, Platter with Flip Up Bar, OIML
MP7011-MNSLM00AU	MP7011 Scanner Scale, Medium, Single Interval Scale, Sapphire, CSS, Platter with Flip Up Bar, Australia
MP7011-MNSLM00EU	MP7011 Scanner Scale, Medium, Single Interval Scale, Sapphire, CSS, Platter with Flip Up Bar, Europe
MP7011-MNSLM00US	MP7011 Scanner Scale, Medium, Single Interval Scale, Sapphire, CSS, Platter with Flip Up Bar, United States
MP7011-MPSLM00US	MP7011 Scanner Scale, Medium, Single Interval Scale, Sapphire, CSS, Platter with Flip Up Bar, Drivers License Parsing, United States
MP7012-LNSLM00EU	MP7012 Scanner Scale, Long, Dual Interval, Sapphire, CSS, Europe

Notes:

1. EU scales are legally accepted in the following countries: Austria, Belgium, Bulgaria, Croatia, Cyprus, Czech Republic, Denmark, Estonia, Finland, France, Germany, Greece, Hungary, Ireland, Iceland, Italy, Liechtenstein, Lithuania, Luxembourg, Latvia, Malta, Netherlands, Norway, Poland, Portugal, Romania, Slovak Republic, Slovenia, Spain, Sweden, Switzerland, and United Kingdom
2. OIML scales are legally accepted in the following countries: Bahamas, Barbados, Belize, Bermuda, Chile, Colombia, Costa Rica, Ecuador, El Salvador, Guatemala, Hong Kong, Jamaica, Saint Lucia, Panama, Peru, Philippines, Thailand, Trinidad, and Tobago
3. The color camera configuration type (portrait or landscape) is noted by the fifth digit after the dash. For example, MP7001-MNSLX00EU includes a P (Portrait camera orientation) or C (Landscape camera orientation).

Table 1-1 MP7000 Scanner Scale Configurations (Continued)

Configuration	Description
MP7012-MNSLM00EU	MP7012 Scanner Scale, Medium, Dual Interval, Sapphire, CSS, Europe
MP7012-LNSLM00NN	MP7012 Scanner Scale, Long, Dual Interval, Sapphire, CSS, OIML
MP7012-MNSLM00NN	MP7012 Scanner Scale, Medium, Dual Interval, Sapphire, CSS, OIML
MP7012-LNSLM00RU	MP7012 Scanner Scale, Long, Dual Interval, Sapphire, CSS, Russia
MP7012-MNSLM00RU	MP7012 Scanner Scale, Medium, Dual Interval, Calibration Switch, Sapphire, CSS, Russia
MP7000 Scanner Scale with Color Camera	
MP7001-MNSLP00EU	Multiplane Scanner, Medium, Single Interval Scale, Color Camera Module Portrait, Sapphire Glass, Europe
MP7001-MNSLP00AU	Multiplane Scanner, Medium, Single Interval Scale, Color Camera Module Portrait, Sapphire Glass, Australia
MP7001-MNSLC00US	Multiplane Scanner, Medium, Single Interval Scale, Color Camera Module Landscape, Sapphire Glass, United States
MP7001-MNSLC00EU	Multiplane Scanner, Medium, Single Interval Scale, Color Camera Module Landscape, Sapphire Glass, Europe
MP7001-LNSLP00NN	Scanner, Single Interval Scale, Long, Color Camera Portrait, Sapphire, OIML
MP7001-LNSLP00CM	Multiplane Scanner, Long, Single Interval Scale, Color Camera Module Portrait, Sapphire Glass, Canada/Mexico
MP7001-LNSLC00NN	Scanner, Single Interval Scale, Long, Color Camera Landscape, Sapphire, OIML
MP7001-LNSLC00CM	Multiplane Scanner, Long, Single Interval Scale, Color Camera Module Landscape, Sapphire Glass, Canada/Mexico
MP7001-LNS0P00US	Multiplane Scanner, Long, Single Interval Scale, Color Camera Module Portrait, Sapphire Glass, United States
MP7001-LNS0P00AU	Multiplane Scanner, Long, Single Interval Scale, Color Camera Module Portrait, Sapphire Glass, Australia
MP7001-LNS0C00US	Multiplane Scanner, Long, Single Interval Scale, Color Camera Module Landscape, Sapphire Glass, United States

Notes:

1. EU scales are legally accepted in the following countries: Austria, Belgium, Bulgaria, Croatia, Cyprus, Czech Republic, Denmark, Estonia, Finland, France, Germany, Greece, Hungary, Ireland, Iceland, Italy, Liechtenstein, Lithuania, Luxembourg, Latvia, Malta, Netherlands, Norway, Poland, Portugal, Romania, Slovak Republic, Slovenia, Spain, Sweden, Switzerland, and United Kingdom
2. OIML scales are legally accepted in the following countries: Bahamas, Barbados, Belize, Bermuda, Chile, Colombia, Costa Rica, Ecuador, El Salvador, Guatemala, Hong Kong, Jamaica, Saint Lucia, Panama, Peru, Philippines, Thailand, Trinidad, and Tobago
3. The color camera configuration type (portrait or landscape) is noted by the fifth digit after the dash. For example, MP7001-MNSLX00EU includes a P (Portrait camera orientation) or C (Landscape camera orientation).

Table 1-1 MP7000 Scanner Scale Configurations (Continued)

Configuration	Description
MP7001-LNS0C00AU	Multiplane Scanner, Long, Single Interval Scale, Color Camera Module Landscape, Sapphire Glass, Australia
MP7001-LND0P00US	Scanner, Single Interval Scale, Long, Color Camera Portrait, Non-sapphire, United States
MP7001-LND0C00US	Scanner, Single Interval Scale, Long, Color Camera Landscape, Non-sapphire, United States
MP7000-SNS0C00WW	Multiplane Scanner, Short, Color Camera Module Landscape, Sapphire Glass, Worldwide
MP7000-MNSLP00WW	Multiplane Scanner, Long, Sapphire Glass, Scale Ready Platter, Third party scale support, Color Camera Module Portrait, Worldwide
MP7000-MNSLC00WW	Multiplane Scanner, Long, Sapphire Glass, Scale Ready Platter, Third party scale support, Color Camera Module Landscape, Worldwide
MP7000-MNSDC00WW	Multiplane Scanner, Long, Sapphire Glass, Scanner only/Scale Ready Platter, Third party scale support, Color Camera Module Landscape, Worldwide
MP7000-MNS0C00WW	Multiplane Scanner, Medium, Color Camera Module Landscape, Sapphire Glass, Worldwide
MP7000-LNS0P00WW	Long Scanner, Sapphire, Color Camera Portrait, Worldwide
MP7000-LNS0C00WW	Multiplane Scanner, Long, Color Camera Module Landscape, Sapphire Glass, Worldwide
MP7000-LCS0C00IN	Long Scanner Scale With Single Interval Scale, Sapphire, calibration Switch, color Camera, India

Notes:

1. EU scales are legally accepted in the following countries: Austria, Belgium, Bulgaria, Croatia, Cyprus, Czech Republic, Denmark, Estonia, Finland, France, Germany, Greece, Hungary, Ireland, Iceland, Italy, Liechtenstein, Lithuania, Luxembourg, Latvia, Malta, Netherlands, Norway, Poland, Portugal, Romania, Slovak Republic, Slovenia, Spain, Sweden, Switzerland, and United Kingdom
2. OIML scales are legally accepted in the following countries: Bahamas, Barbados, Belize, Bermuda, Chile, Colombia, Costa Rica, Ecuador, El Salvador, Guatemala, Hong Kong, Jamaica, Saint Lucia, Panama, Peru, Philippines, Thailand, Trinidad, and Tobago
3. The color camera configuration type (portrait or landscape) is noted by the fifth digit after the dash. For example, MP7001-MNSLX00EU includes a P (Portrait camera orientation) or C (Landscape camera orientation).

Peripherals

The MP7000 Scanner Scale supports the peripheral devices listed below.

Supported Auxiliary Hand-held Scanner

The MP70XX provides auxiliary data ports (USB and RS-232) to which a hand-held scanner can be connected.



NOTE An auxiliary cordless scanner, such as the DS8178, can be attached to the MP70XX. If a standard cradle is used with the scanner, a separate cradle power supply is required.



IMPORTANT The MP70XX scanner does not configure an auxiliary scanner. Auxiliary scanners must be configured separately, independently of the MP70XX scanner.

EAS Devices

- Sensormatic AMB-9010 controller
- Sensormatic AMB-9010-IPS controller
- Checkpoint controller
- Checkpoint with interlock controller.

See *Electronic Article Surveillance (EAS)* on page 5-15 for detailed information.

Scale Devices

- OEM standard scale
- Single/dual head Scale Displays.
- Mettler-Toledo price computing scale for parts of Europe (available September 2017).

USB Flash Drives

- Typical USB flash drive with Type A connector. (See *USB Staging Flash Drive* on page 5-10.)

Customer Side Scanner (CSS)

- The CSS (MX101) is an optional integrated device that supports 1D and 2D barcode scanning. The CSS unit replaces the MP70XX tower cover, and can be installed on either side of the MP70XX.

Related Product Line Configurations

Check Solution Builder for additional information regarding all available accessories, and the latest available configurations.

Features of the MP7000 Scanner Scale

The following illustrations of the medium model show the features of the MP70XX. See [Table 1-2 on page 1-15](#) for brief descriptions of all features. See *Controls and Indicators on page 5-1* for detailed descriptions of each feature.

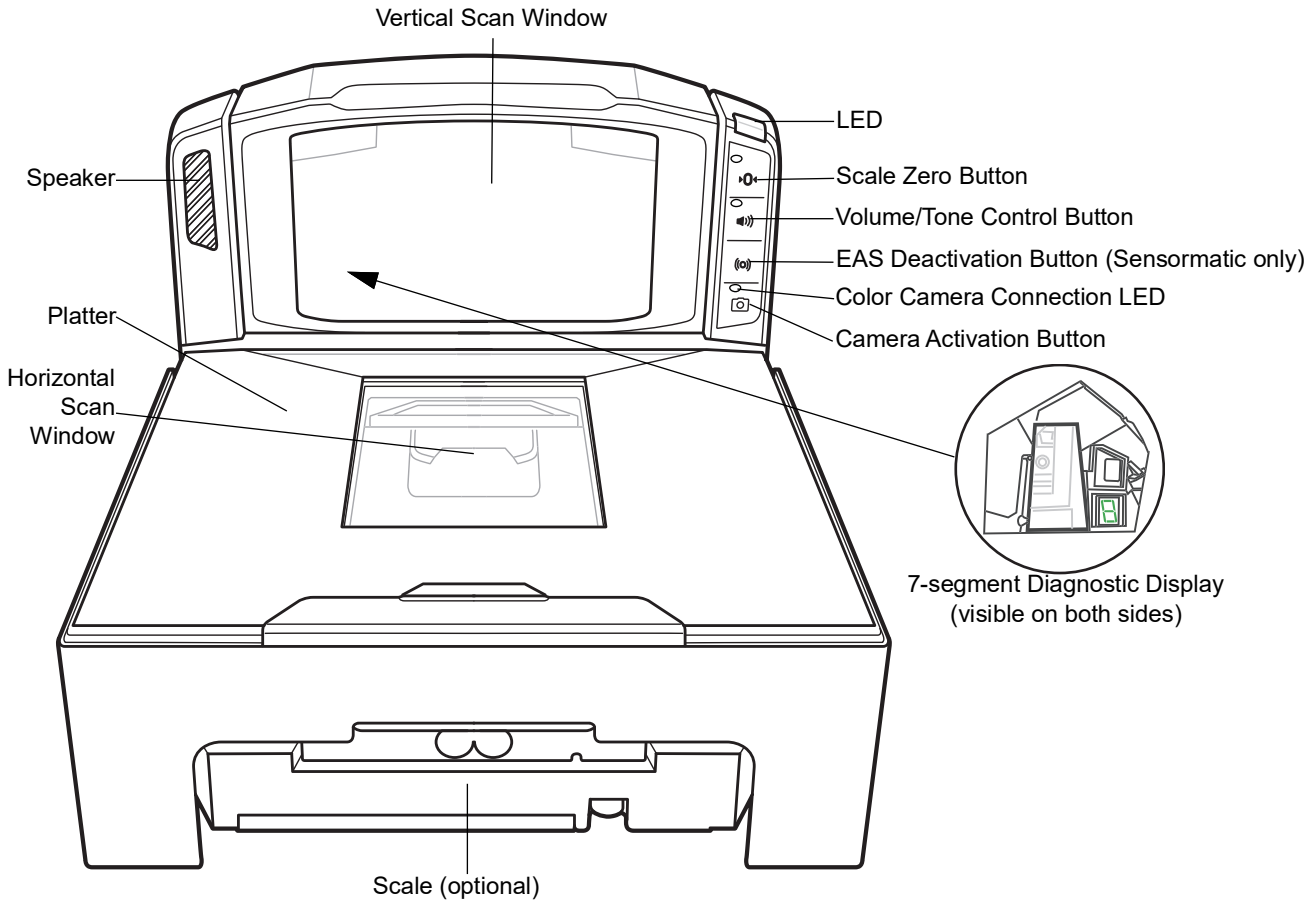

Figure 1-1 MP70XX Front View

1 - 10 MP7000 Scanner Scale Integrator Guide

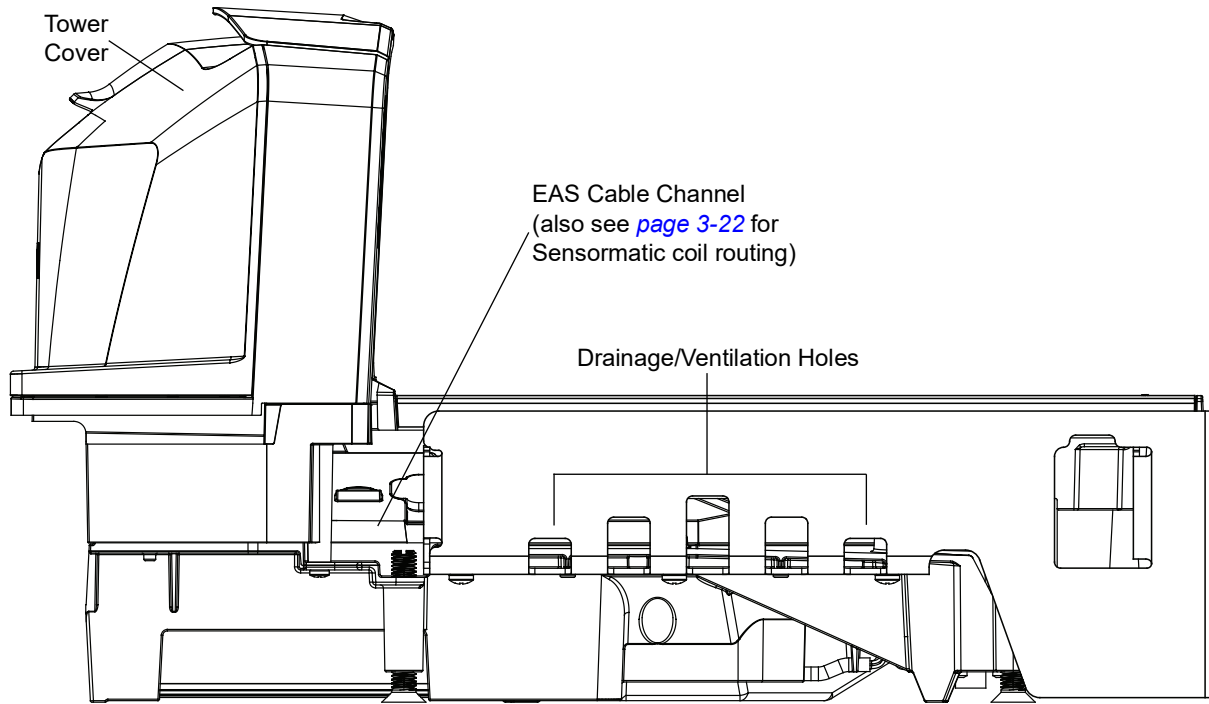

Figure 1-2 Left Side View

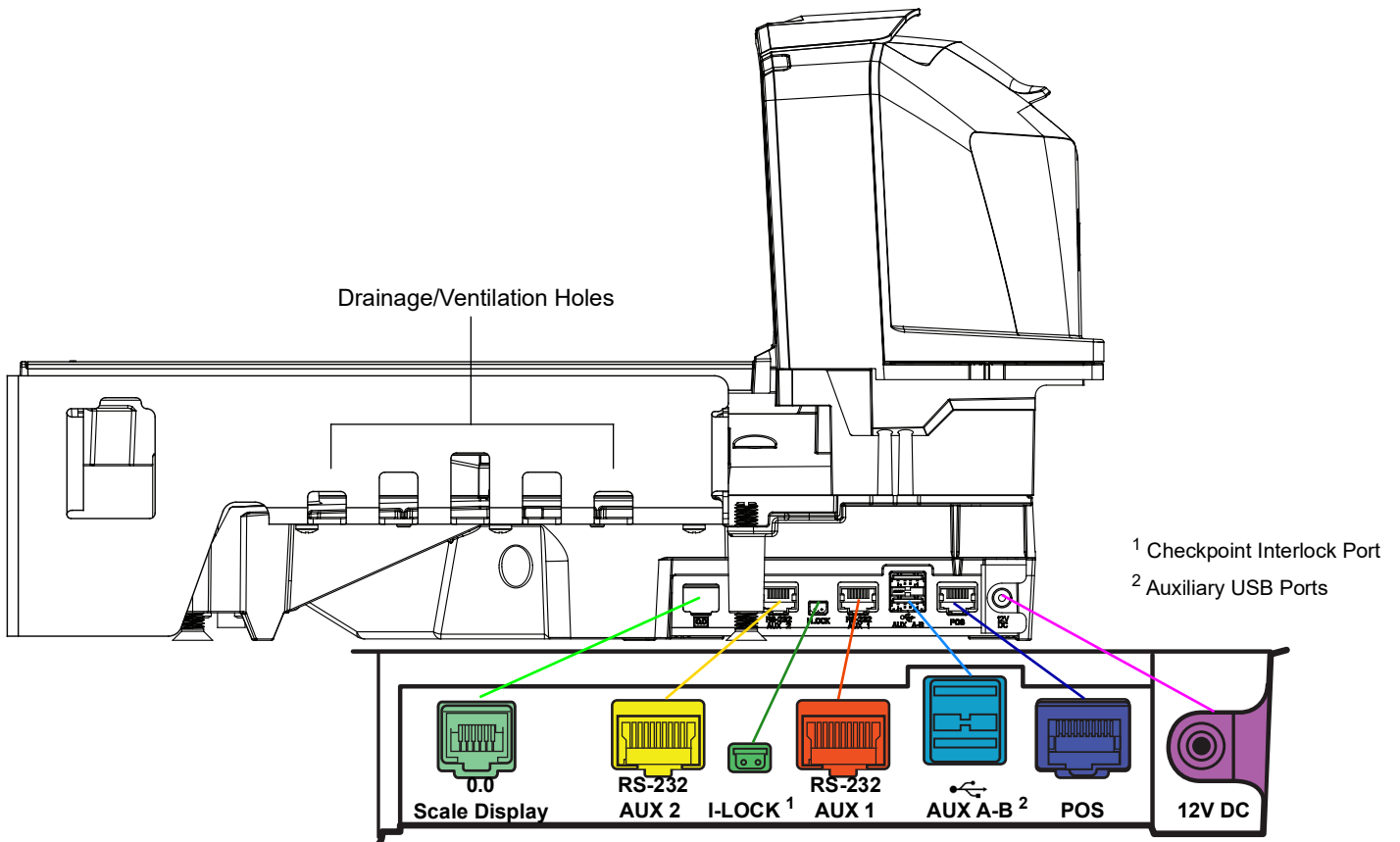

Figure 1-3 Right Side View/Connector Ports

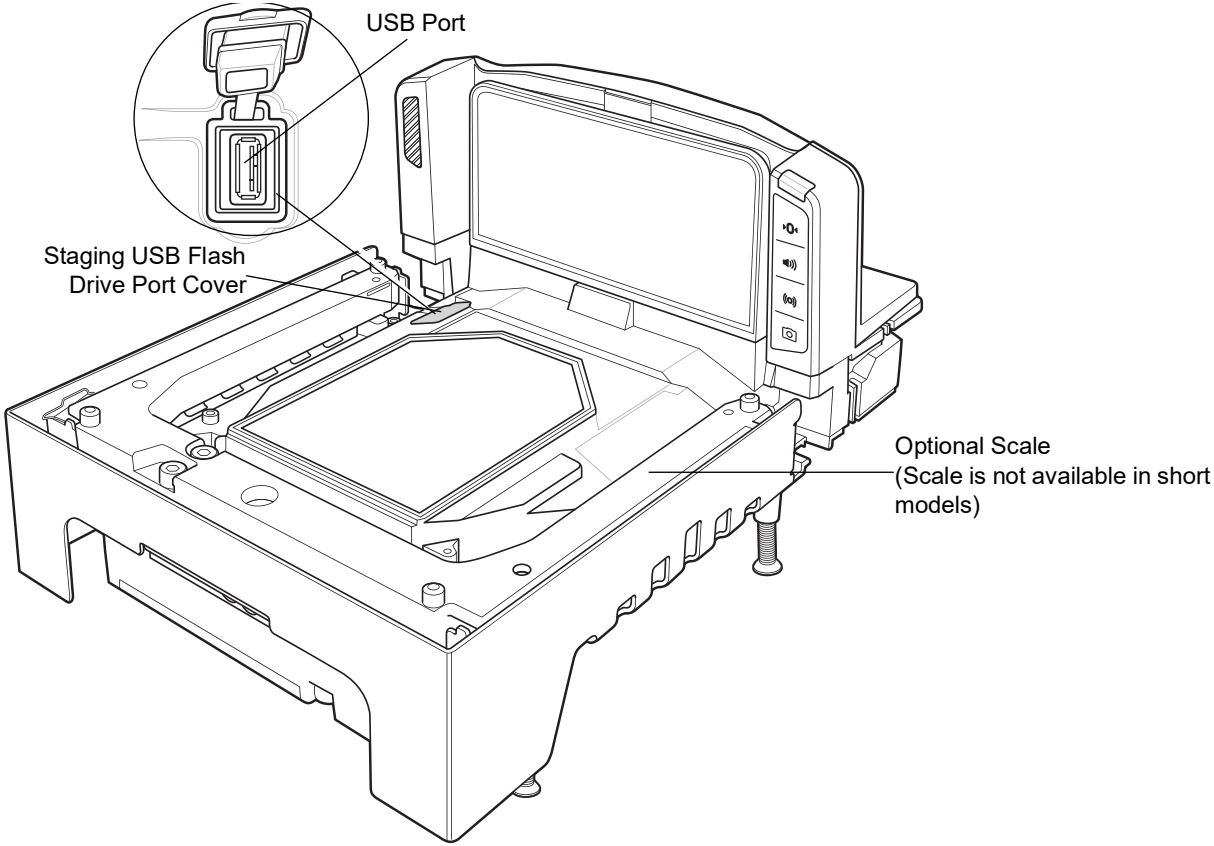
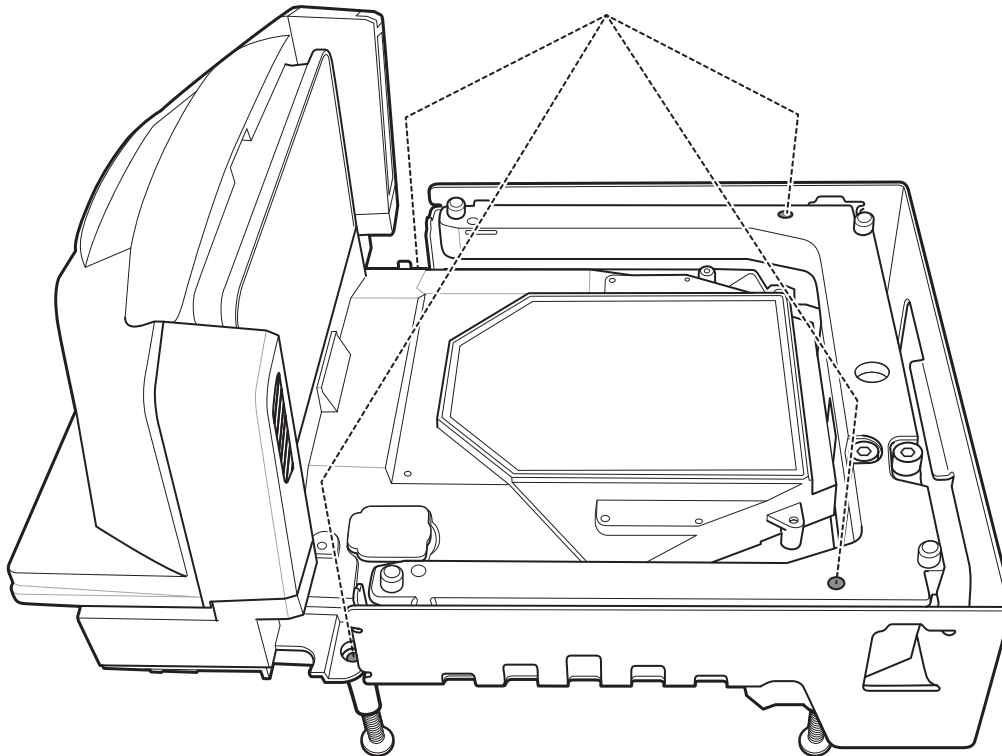

Figure 1-4 View Under Platter



NOTE

Leveling screws accessory kit MX301-SR00004ZZWR is shipped with every short and medium model.

Longer leveling screws with a 1 in. (25 mm) extra length are available for purchase, if required (accessory kit p/n MX302-SR00004ZZWR).

Figure 1-5 Leveling Screws

Scale Displays (Some Scanner/Scale Configurations Only)

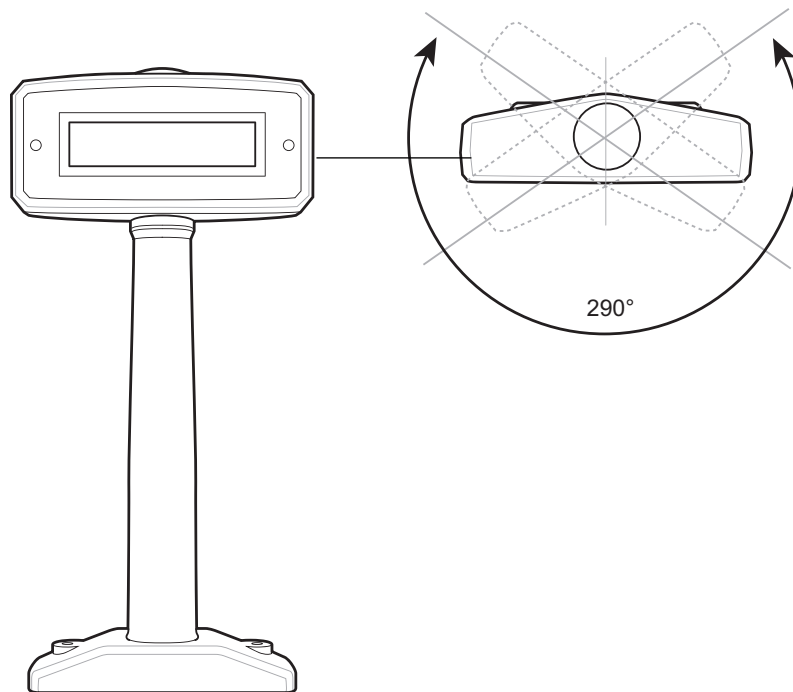

Figure 1-6 Single Head Scale Display



NOTE The MX201-SI00WW supports the single interval scale - lbs and kg; the MX201-DI00WW supports the dual interval scale - lbs and kg.

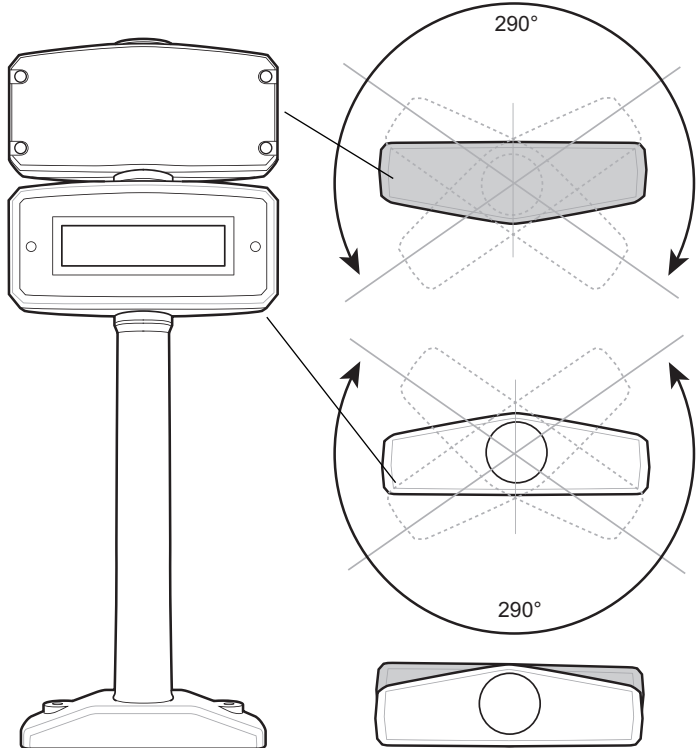

Figure 1-7 Dual Head Scale Display

✓ **NOTE** The MX202-SI00WW supports the single interval scale - lbs and kg; the MX202-DI00WW supports the dual interval scale - lbs and kg.

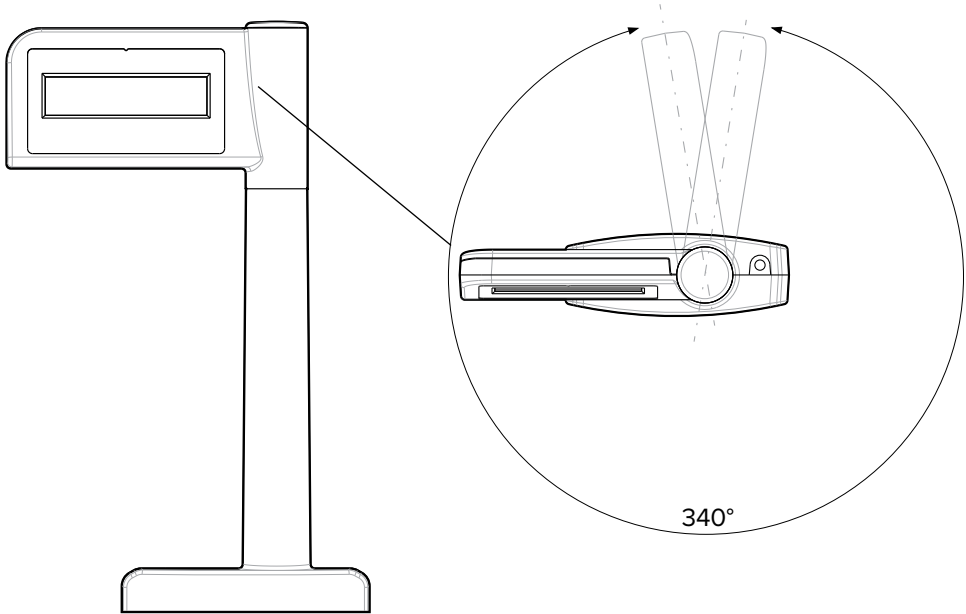

Figure 1-8 Single Head Pole Display

- ✓ **NOTE** The MX203-D200KG, MX203-S200LB, MX203-S200KG, MX203-S200BR supports the single interval scale - lbs and kg.

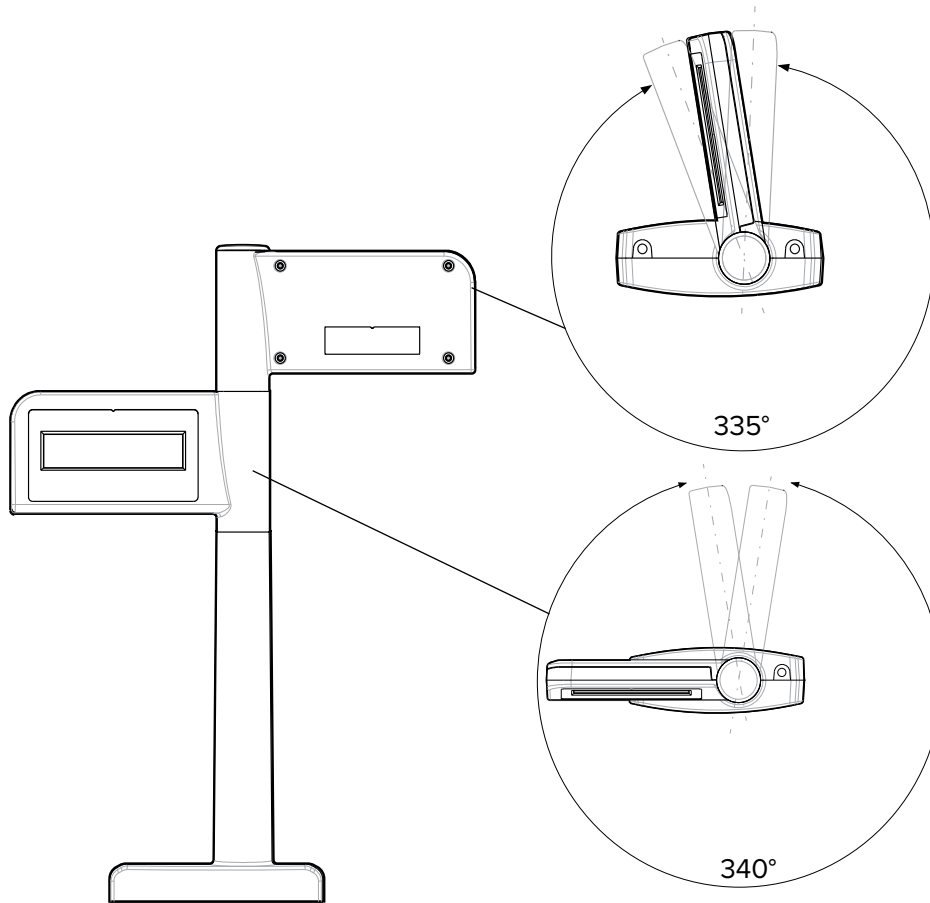

Figure 1-9 *Dual Head Pole Display*

- ✓ **NOTE** The MX204-S200LB, MX204-S200KG, and MX204-D200KG supports the dual interval scale - lbs and kg.

Flip Up Produce Bar (Standard on all Scale Models)

The Flip Up Produce Bar is used to help weigh very long or round items. This helps prevent the items from falling off the scale and ensures accurate weighing.

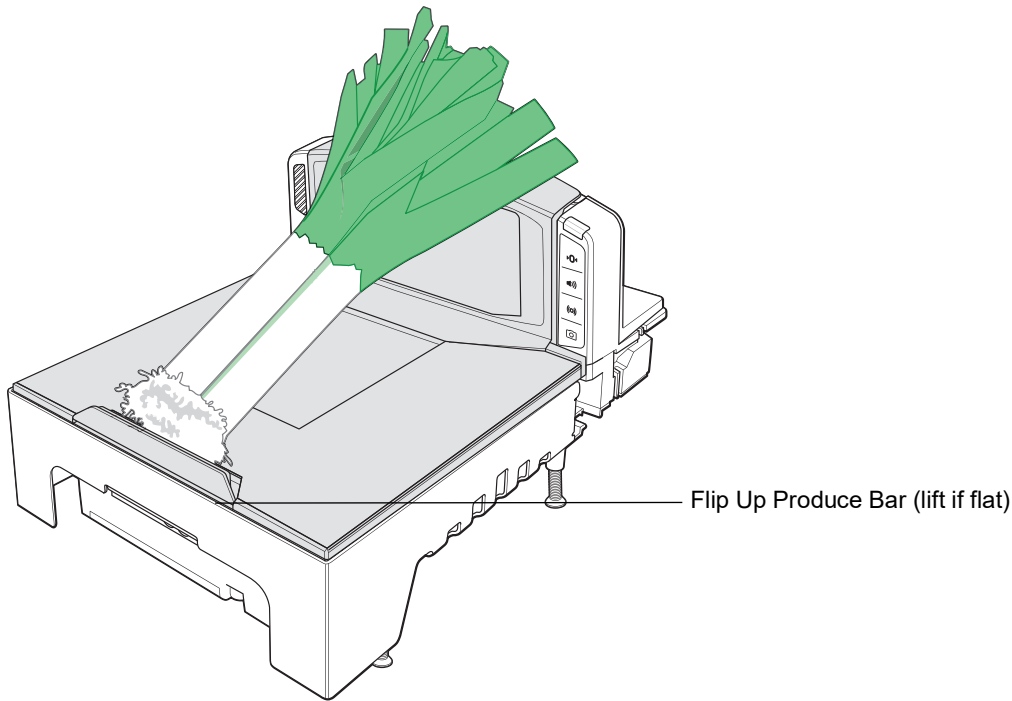

Figure 1-10 MP70XX with Optional Leek Platter

Features Summary

Table 1-2 Features on the MP7000 Scanner Scale

Feature	Description	Page
Diagnostic LED/7-segment Display	Internal display provides detailed status, troubleshooting information, and scale legal parameters during calibration.	5-2
LED	Provides visual feedback for system statuses and alerts.	5-1
Scale Zero Button	Scale status LED and touch button provides scale status, and allows user to zero the scale.	5-3
Volume/Tone Control Button	User selectable settings for audible system indications. (Status LED and button.)	5-3
EAS Deactivation Button (Sensormatic only)	Indicates the state of the Sensormatic EAS device, and controls manual deactivation (optional).	5-4

Table 1-2 Features on the MP7000 Scanner Scale (Continued)

Feature	Description	Page
Color Camera Connection LED	When green, verifies that the MP7000 color camera is on. Disconnecting/connecting the MXC7000 USB cable causes the device to beep and toggle the LED (up to a 10 second delay).	See Chapter 6, Color Camera Installation and Use for color camera details.
Camera Activation Button	Allows a customer to take a picture.	5-4
Scale (Optional/ Scanner Scale Configurations Only)	Scales are available for the medium length and long length configurations.	5-5
Platter	Stainless steel horizontal scanning surface; imaging window for processing barcode data, and placing items on the surface to determine weight.	5-6
Calibration Switch	Used in manual scale calibration.	n/a
CSS (Optional)	Modular unit that fits into the MP70XX tower; used for customer scanning.	3-12
Scale Display	Single or dual display option provides the weight of items on the scale.	5-5
Leveling Screws (medium and short models only)	Standard length leveling screws ship with all short and medium models. Longer length screws are available as an accessory.	1-12
Connectors	Connect the MP70XX to peripherals, and POS/host.	Table 1-3
Internal USB Cap/Port	The internal USB port is available under the platter.	1-12
EAS Cable Channel	Cable routing channel for EAS antenna.	1-10
Scale Cable Channel	Cable routing channel for the scale cable.	1-10
Drainage/Ventilation Holes	Outlet for spills.	1-10

Table 1-3 Description of Connectors

Port	Description
RS-232 AUX 2 (J7)	See Table 2-3 on page 2-13 for description.
0.0 (J6)	Scale Display port.
RS-232 AUX 1 (J5)	See Table 2-3 on page 2-13 for description.
CKP I-LOCK (J4)	Checkpoint EAS Interlock.

Table 1-3 Description of Connectors

Port	Description
AUX A-B (J3)	Dual USB 2.0 full speed ports for auxiliary USB scanners, CSS, or mass storage device. NOTE An additional USB port is available in the front under the platter. All USB ports can be used for the USB staging flash drive. See Table 2-15 on page 2-64 and USB Staging Flash Drive on page 5-10 for more information.
POS (J2)	Point of Sale terminal port.
12V DC (J1)	External power input. 12V / 3.33A (not required if powered from terminal). NOTE If a power supply plug is inserted to the J1 connector, with no voltage to the power supply, the scanner will not power up.

CHAPTER 2 HOST INTERFACES AND CABLE PINOUTS

Introduction

This chapter describes the host interfaces supported by the MP7000 Scanner Scale, and how to connect the MP70XX to a host. It also include host interface barcodes. See [Figure 1-1 on page 1-9](#) for locations of the interface connectors.

OPOS/JAVAPOS settings are outside the scope of this guide. For the Zebra SDK, go to: zebra.com/scannersdkforwindows.

- ✓ **NOTE** SDK supported functionality by communication protocol is listed in [Appendix E, Communication Protocol Functionality](#).

Interfaces, Components, and Communication

The MP70XX supports the following.

POS Interfaces and Host Communication



IMPORTANT Avoid inserting a POS cable in the AUX 1 or AUX 2 port.

- USB 2.0 full speed using Zebra USB multi-host cables
- RS-232 connection using several communication protocols.
- RS-485 communication protocol.

- ✓ **NOTE** SDK supported functionality by communication protocol is listed in [Appendix E, Communication Protocol Functionality](#).

Auxiliary Ports and Peripherals

- Three USB 2.0 full speed auxiliary ports (see [AUX A-B \(Stacked USB\)](#) on page 2-64).
- Two RS-232 auxiliary ports (AUX 1/AUX 2; see [Figure 1-3 on page 1-10](#)).

The MP70XX can support the following combinations of peripherals:

- Hand-held scanners supported in USB mode, or RS-232 mode.
- CSS (CSS is USB only).

✓ **NOTE** A total of one hand-held scanner plus one CSS is supported.

- Wireless auxiliary scanner support may be provided via a corded cradle as an auxiliary device.

✓ **NOTE** An auxiliary cordless scanner, such as the DS8178, can be attached to the MP70XX. If a standard cradle is used with the scanner, a separate cradle power supply is required.

- Sensormatic controller via the RS-232 auxiliary port.



IMPORTANT Use only Zebra approved cables when connecting peripherals to the ports on the MP70XX.

- Dual cable scanner/scale: Via RS-232 AUX 1, or RS-232 AUX 2 ports (see [Figure 1-3 on page 1-10](#), and [Table 2-3 on page 2-13](#)).

Programming Management Tools

- 123Scan (see [Chapter 7, 123Scan and Software Tools](#))
- SMS
- Staging flash drive reprogramming (USB memory stick).

✓ **NOTE** Only Zebra hand-held scanners can be managed via 123Scan (see [Chapter 7, 123Scan and Software Tools](#)), and SMS through the MP70XX scanner.

Application Programming Interfaces

- Zebra scanner SDK APIs (CoreScanner APIs).

✓ **NOTE** SDK supported functionality by communication protocol is listed in [Appendix E, Communication Protocol Functionality](#).

- Zebra scanner OPOS/JPOS APIs.

For access to these programming interfaces, go to: zebra.com/scannersdkforwindows.

✓ **NOTE** If the MP70XX is powered up with no interface cable present, it reverts to “no host mode.” This is useful for demonstrations where no host is present.

USB Interface

Connecting

- ✓ **NOTE** For a list of supported scanner functionality by communication protocol see [Appendix E, Communication Protocol Functionality](#).

The MP70XX connects directly to a USB host. An additional power supply may be required (PWR-BGA12V50W0WW - power supply; CBL-DC-388A1-01 - DC cable). Only a USB Power Plus host can power the MP70XX using a Zebra Power Plus cable, without an external power supply.

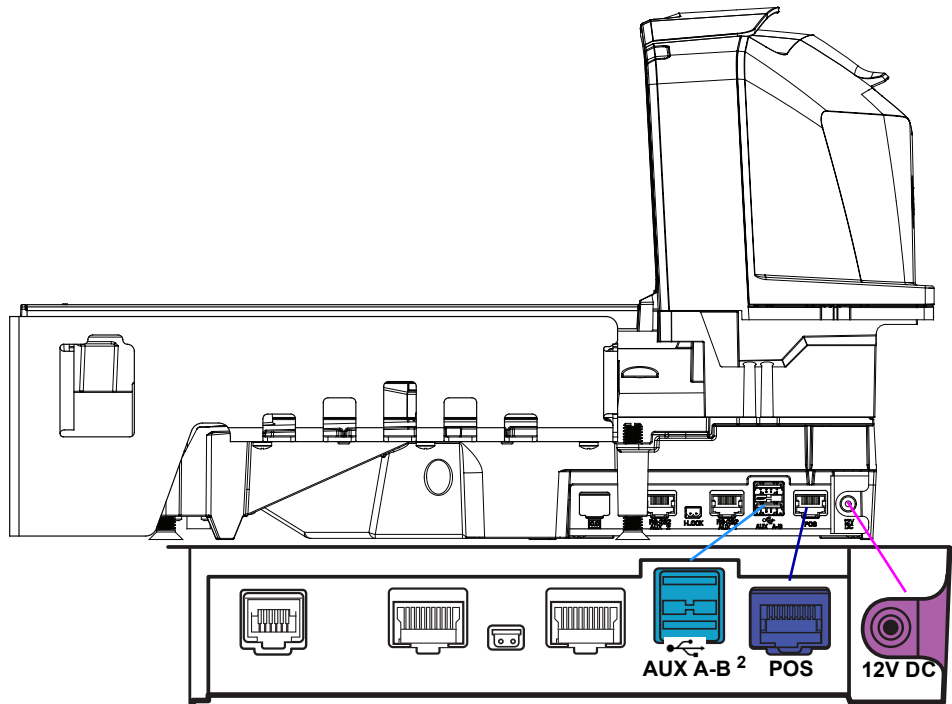

Figure 2-1 *USB Connections*

- ✓ **NOTE** Interface cables vary depending on configuration.

There are three possible USB connection methods for the MP70XX:

- POS connection using USB Power Plus (12V); requires a CBA-U52-S16PAR cable between POS equipment (e.g., IBM) and the MP70XX POS RJ-45 connector. The MP70XX is a USB device for this connection; no power supply is required (the MP70XX draws power from USB cable).
- POS connection using USB Standard A (5V); requires a CBA-U51-S16ZAR cable between POS equipment (standard device - PC) and MP70XX POS RJ-45 connector. The MP70XX is USB device but requires an external power supply (MP70XX does NOT draw power from USB cable).
- AUX scanner connection using a Zebra USB hand-held scanner; requires a Zebra USB type A cable between the Zebra USB hand-held scanner (RJ-45), and the MP70XX AUX A-B USB port. The MP70XX is the USB host, and the Zebra scanner is the USB device which draws power from 5V cable.

To set up the MP70XX:

1. Connect the RJ-45 modular connector of the USB interface cable to the POS interface port on the MP70XX.
2. Plug the series A connector, or the Power Plus connector in the USB host. If Power Plus is used, the MP70XX powers up with the POS.
3. If no Power Plus is used, connect a 12V power supply. Connecting the 12V power supply immediately turns the unit on.
4. Select the USB device type by scanning the appropriate barcode (see [USB Device Type on page 2-4](#)).
5. To modify any parameter options:
 - a. Scan the appropriate barcodes in the *MP7000 Scanner Scale Barcode Programming Guide* (p/n MN-002912-xx).
or
 - b. Use 123Scan.
or
 - c. Use the 123Scan 2D configuration barcode.
or
 - d. Use a USB staging flash drive (see [USB Staging Flash Drive on page 5-10](#)).

USB Host Parameters

USB Device Type

To select a USB device type, scan one of the barcodes listed in [Table 2-1](#).

- ✓ **NOTE**
1. When changing USB device types, the MP70XX automatically resets and issues the standard startup beep sequences.
 2. Before scanning [CDC COM Port Emulation on page 2-9](#), install the appropriate USB CDC Driver on the host to ensure the scanner does not stall during power up (due to a failure to enumerate USB). Go to zebra.com/support, Support & Downloads > Barcode Scanners > USB CDC Driver, select the appropriate Windows platform, and download either Zebra_CDC_ACM_Driver_(x64)v2.15.0004.exe (64 bit) or Zebra_CDC_ACM_Driver(x86)_v2.15.0004.exe (32 bit).

To recover a stalled scanner:

Install the USB CDC Driver

or

Unplug the USB cable (at the MP70XX side), add power and scan * [IBM Table-top USB on page 2-5](#) or any other non-USB CDC host.

- ✓ **NOTE** This guide includes limited parameter barcodes. For ALL MP70XX programming barcodes, refer to the *MP7000 Scanner Scale Barcode Programming Guide* (p/n MN-002912-xx).

Table 2-1 *USB Host Parameters*

Parameter	Page Number
USB Device Type	
IBM Table-top USB (default)	2-5
IBM Hand-held USB	2-6

Table 2-1 *USB Host Parameters (Continued)*

Parameter	Page Number
IBM OPOS (IBM Hand-held USB with Full Scan Disable)	2-7
HID Keyboard Emulation	2-8
CDC COM Port Emulation	2-9
Symbol Native API (SNAPI) with Imaging Interface	2-10
Symbol Native API (SNAPI) without Imaging Interface	2-11

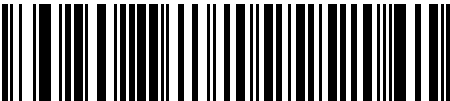

* IBM Table-top USB

USB Device Type (continued)

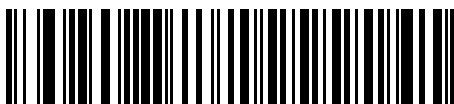

IBM Hand-held USB

USB Device Type (continued)



**IBM OPOS
(IBM Hand-held USB with Full Scan Disable)**

USB Device Type (continued)



When the HID Keyboard host is selected, and the MP70XX has auxiliary scanners connected, use ADF rules to program the auxiliary scanners to add a 500 msec pause to the end of the data to prevent the interleaving of barcode data from multiple scanners. This works with standard RS-232, and SSI over RS-232 (with the Send Raw Decode Data setting).

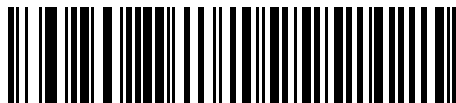

HID Keyboard Emulation

USB Device Type (continued)



CDC COM Port Emulation

USB Device Type (continued)



Symbol Native API (SNAPI) with Imaging Interface

USB Device Type (continued)



Symbol Native API (SNAPI) without Imaging Interface

RS-232 Interface

Connecting

- ✓ **NOTE** For a list of supported scanner functionality by communication protocol [Appendix E, Communication Protocol Functionality](#).

MP7000 Scanner Only or MP7200/7500 Scale with Single Cable Protocol

Use the RS-232 interface to connect the MP70XX to POS devices, host computers, or other devices with an available RS-232 port (e.g., com port).

- ✓ **NOTE** The MP70XX uses +/-6V RS-232 signal levels to accommodate long cable lengths, and increased noise immunity.

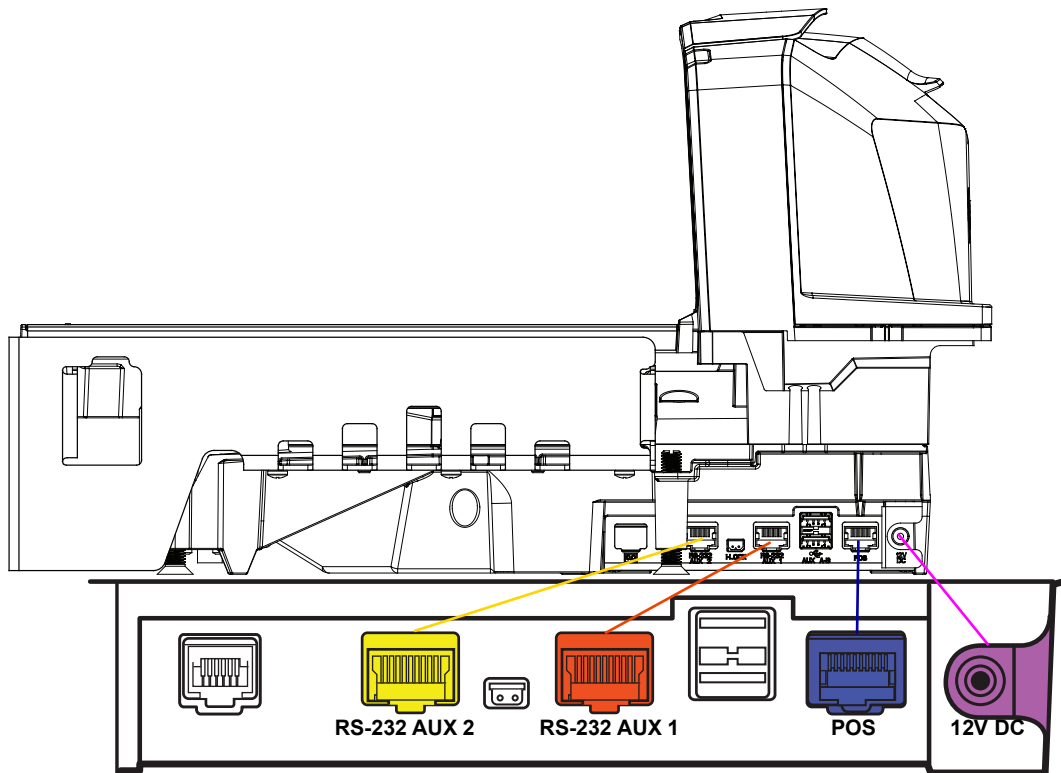

Figure 2-2 RS-232 Connections

- ✓ **NOTE** Interface cables vary depending on configuration.

Table 2-2 *Host Connections*

Port	Connection Options			
POS	Standard USB (p/n CBA-U51-S16ZAR)	USB PlusPower (p/n CBA-U52-S16PAR)	RS-232 (p/n CBA-R51-S16ZAR)	RS-485 (p/n CBA-M51-S16PAR)

Table 2-3 *Auxiliary Connections*

Configuration Choices for the Devices Below	RS-232 Device Port Configuration Value (see parameter 1246 page 2-33)	Connect Device to These Ports			
		AUX 1	AUX 2	USB2	USB3
RS-232 auxiliary scanner, and a Sensormatic Controller ³	0 ¹	Sensormatic Controller	RS-232 auxiliary scanner ³	USB auxiliary scanner ³	USB auxiliary scanner ³
RS-232 auxiliary scanner, and a Dual Cable Scanner/Scale ³	1	Dual Cable Scanner/Scale ²	RS-232 auxiliary scanner ³	USB auxiliary scanner ³	USB auxiliary scanner ³
Dual Cable Scanner/Scale, and a Sensormatic Controller ³	2	Sensormatic Controller	Dual Cable Scanner/Scale ²	USB auxiliary scanner ³	USB auxiliary scanner ³
Third-Party-Scale & Sensormatic-Controller	4	Third-Party-Scale	Sensormatic Controller	USB auxiliary scanner ³	USB auxiliary scanner ³

¹ Default setting

² The Dual Cable Scanner/Scale supports the industry standard SASI, DIGI, ICL OMRON, ICL Old OMRON, ICL Portugal, scale-only protocols. The default protocol on this Dual Cable Scanner/Scale port is SASI.

³ In all configurations up to one or two additional USB auxiliary scanners can be connected, but the total RS-232 auxiliary scanners plus USB auxiliary scanners cannot exceed two. An auxiliary scanner is not counted until it is attached.

Price Computational Scale Interface Circuit Drawing

Price Computational Scale Interface available on AUX 1. (Also see [Third Party Scale on page 2-46.](#))

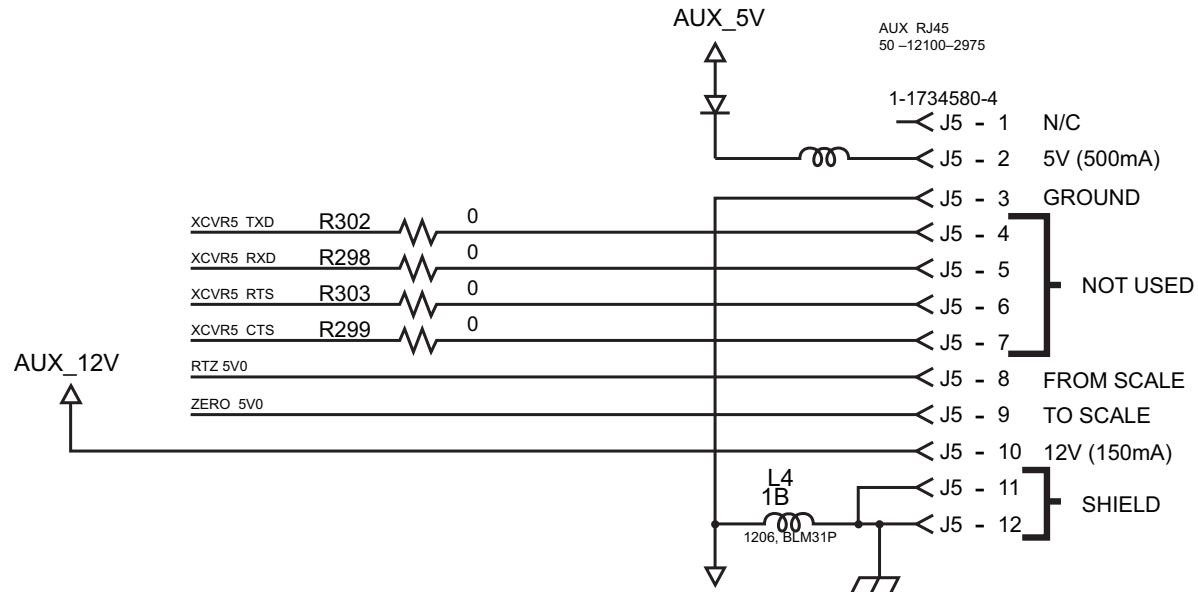

Figure 2-3 Price Computational Scale Interface

Connecting to an RS-232 Host

To connect the MP70XX to an RS-232 host:

1. Connect the modular connector of the RS-232 interface cable to the POS interface port on the MP70XX.
2. Connect the other end of the RS-232 interface cable to the serial port on the host.
3. Connect a 12V power supply directly to the MP70XX.
4. Select the RS-232 host type by scanning the appropriate barcode (see [RS-232 Host Types on page 2-21](#)). If your host does not appear in the terminal specific tables, refer to the documentation for the host device to set communication parameters to match the host.
5. To modify any other parameter options, scan the appropriate barcodes in the *MP7000 Scanner Scale Barcode Programming Guide* (p/n MN-002912-xx).

Models with a Dual Cable Scanner/Scale

Use the RS-232 interface to connect the MP70XX to POS devices, host computers, or other devices with an available RS-232 port (e.g., com port). Then use a second RS-232 cable (p/n CBA-R51-S16ZAR to connect the MP70XX Dual Cable Scanner/Scale AUX port to a scale-only port on the POS device.

The Dual Cable Scanner/Scale interface supports the industry standard SASI scale-only protocol, and communicates with a POS using a 9600 baud rate, 7 data bits, and even parity.

To set up the MP70XX and Dual Cable Scanner/Scale:

1. Attach the RJ-45 modular connector of the RS-232 scanner interface cable to the POS port on the MP70XX. Connect the other end of the RS-232 scanner interface cable to the serial scanner port on the host.
2. Attach the RJ-45 end of the RS-232 interface cable to AUX 2 (see [Figure 1-3 on page 1-10](#)) on the MP70XX. Connect the other end of the RS-232 interface cable to the scale-only port on the host.
3. Connect the power supply directly to the MP70XX.

4. Select the RS-232 scanner host type by scanning the appropriate barcode (see [RS-232 Host Types on page 2-21](#)). If your host does not appear in the terminal specific tables, refer to the documentation for the host device to set communication parameters to match the host. To modify any other parameter options, scan the appropriate barcodes in the *MP7000 Scanner Scale Barcode Programming Guide* (p/n MN-002912-xx).
5. The protocol on this Dual Cable Scanner/Scale port is SASI.
6. Select the device port configuration by scanning the appropriate barcode (refer to the *MP7000 Scanner Scale Barcode Programming Guide* for RS-232 device port configuration).
7. Cycle power on the MP70XX.

RS-232 Parameters

✓ **NOTE** This guide includes limited parameter barcodes. For ALL MP70XX programming barcodes, refer to the *MP7000 Scanner Scale Barcode Programming Guide* (p/n MN-002912-xx).

Table 2-4 RS-232 Host Parameters

Parameter	Page Number
RS-232 Host Type	
Standard RS-232 (default)	2-22
ICL RS-232	2-23
Wincor-Nixdorf RS-232 Mode A	2-24
Wincor-Nixdorf RS-232 Mode B	2-25
Olivetti ORS4500	2-26
Omron	2-27
OPOS/JPOS	2-28
Fujitsu RS-232	2-29
CUTE	2-30
NCR Variant	2-31
Datalogic Variant	2-32
RS-232 Device Port Configuration	
AUX 1 Sensomatic and AUX 2 RS-232 Scanner (default)	2-34
Third Party Scale	
Disable Third Party Scale (default - Disable)	2-47
Third Party Scale LED Pin (default - Active High)	2-49
Third Party Scale Zero Pin (default - Active High)	2-51

RS-232 Host Parameters

Various RS-232 hosts use their own parameter default settings. Selecting standard, ICL, Fujitsu, Wincor-Nixdorf Mode A, Wincor-Nixdorf Mode B, OPOS/JPOS, Olivetti, Omron, Common Use Terminal Equipment (CUTE-LP/LG barcode readers), NCR, or Datalogic sets the defaults listed in [Table 2-5](#) and [Table 2-6](#).



NOTE All items listed in [Table 2-5](#) and [Table 2-6](#) are for scanner only connections, except for NCR which can support scanner and scale.

RS-232 Terminal Specific Parameters

Table 2-5 *RS-232 Terminal Specific Parameters*

Parameter	ICL	Fujitsu	Wincor-Nixdorf Mode A	Wincor-Nixdorf Mode B/OPOS/JPOS
Baud Rate	9600	9600	9600	9600
Parity	Even	None	Odd	Odd
Stop Bit Select	One	One	One	One
ASCII Format	8-Bit	8-Bit	8-Bit	8-Bit
Hardware Handshaking	RTS/CTS Option 3	None	RTS/CTS Option 3	RTS/CTS Option 3
Software Handshaking	None	None	None	None
Serial Response Timeout	9.9 Sec.	2 Sec.	None	None
RTS Line State	High	Low	Low	Low = No data to send
Beep On <BEL>	Disable	Disable	Disable	Disable
Transmit Code ID	Yes	Yes	Yes	Yes
Data Transmission Format	Data/Suffix	Data/Suffix	Data/Suffix	Data/Suffix
Prefix	None	None	None	None
Suffix	CR (1013)	CR (1013)	CR (1013)	CR (1013)

In the Nixdorf Mode B, if CTS is low, scanning is disabled. When CTS is high, scanning is enabled. If you scan Nixdorf Mode B without connecting the digital scanner to the proper host, it may appear unable to scan. If this happens, scan a different RS-232 host type within 5 seconds of cycling power to the digital scanner.

RS-232 Terminal Specific Parameters (continued)**Table 2-6** *RS-232 Terminal Specific Parameters*

Parameter	Olivetti	Omron	CUTE	NCR (Single Cable Scale)	Datalogic
Baud Rate	9600	9600	9600	9600	9600
Parity	Even	None	Even	Odd	Odd
Stop Bit Select	One	One	One	One	One
ASCII Format	7-Bit	8-Bit	7-Bit	7-Bit	7-Bit
Hardware Handshaking	None	None	None	None	None
Software Handshaking	ACK/NAK	None	None	None	None
Serial Response Timeout	9.9 Sec.	9.9 Sec.	9.9 Sec.	9.9 Sec.	9.9 Sec.
RTS Line State	Low	High	High	High	High
Beep On <BEL>	Disable	Disable	Disable	Disable	Enable
Transmit Code ID	Yes	Yes	Yes	Yes	Yes
Data Transmission Format	Prefix/Data/Suffix	Data/Suffix	Prefix/Data/ Suffix	Prefix/ Suffix *	Data/Suffix
Prefix	STX (1002)	None	STX (1002)	STX *	None
Suffix	ETX (1003)	CR (1013)	CR (1013) ETX (1003)	ETX *	CR (1013)

The CUTE host disables all parameter scanning, including Set Defaults. If you inadvertently select CUTE, scan Enable Parameter Barcode Scanning (located in the *MP7000 Scanner Scale Barcode Programming Guide*) then change the host selection.

RS-232 Terminal Specific Code ID Characters

Selecting ICL, Fujitsu, Wincor-Nixdorf Mode A, Wincor-Nixdorf Mode B, OPOS/JPOS, Olivetti, Omron, Common Use Terminal Equipment (CUTE-LP/LG barcode readers), NCR, or Datalogic enables the transmission of code ID characters listed in [Table 2-7](#) and [Table 2-8](#). These code ID characters are not programmable and are separate from the Transmit Code ID feature. Do not enable the Transmit Code ID feature for these terminals.

Table 2-7 Terminal Specific Code ID Characters

Code Type	ICL	Fujitsu	Wincor-Nixdorf Mode A	Wincor-Nixdorf Mode B/ OPOS/JPOS
UPC-A	A	A	A	A
UPC-E	E	E	C	C
EAN-8/JAN-8	FF	FF	B	B
EAN-13/JAN-13	F	F	A	A
Bookland EAN	F	F	A	A
Code 39	C <len>	None	M	M
Code 39 Full ASCII	None	None	M	M
Trioptic	None	None	None	None
Code 32	None	None	None	None
Codabar	N <len>	None	N	N
Code 128	L <len>	None	K	K
GS1-128	L <len>	None	P	P
Code 93	None	None	L	L
I 2 of 5	I <len>	None	I	I
D 2 of 5	H <len>	None	H	H
MSI	None	None	O	O
IATA	H<len>	None	H	H
GS1 Databar Variants	None	None	E	E
PDF417	None	None	Q	Q
MicroPDF417	None	None	S	S
Data Matrix	None	None	R	R
QR Codes	None	None	U	U
Aztec/Aztec Rune	None	None	V	V

* 2D barcodes are not supported.

RS-232 Terminal Specific Code ID Characters (continued)Table 2-8 *Terminal Specific Code ID Characters*

Code Type	Olivetti	Omron	CUTE	NCR	Datalogic
UPC-A	A	A	A	A	A
UPC-E	C	E	None	E	E
EAN-8/JAN-8	B	FF	None	FF	FF
EAN-13/JAN-13	A	F	A	F	F
Bookland EAN	A	F	None	None	None
Code 39	M <len>	C <len>	3	B1	*
Code 39 Full ASCII	None	None	3	None	None
Trioptic	None	None	None	None	\$T
Code 32	None	None	None	None	AE
Codabar	N <len>	N <len>	None	None	%
Code 128	K <len>	L <len>	5	B3	#
GS1-128	P <len>	L <len>	5	None	None
Code 93	L <len>	None	None	None	&
I 2 of 5	I <len>	I <len>	1	B2	i
D 2 of 5	H <len>	H <len>	2	None	None
MSI	O <len>	None	None	None	@
IATA	H<len>	H<len>	2	None	IA
GS1 DataBar Variants	None	None	None	je0	GS1 DataBar - R4 GS1 DataBar Limited - RL GS1 DataBar Expanded - RX
PDF417	None	None	6	jL2*	P
MicroPDF417	None	None	6	jL2*	mP
Data Matrix	None	None	4	jd0*	Dm
QR Codes	None	None	7	jQ0	QR
Aztec/Aztec Rune	None	None	8	jz0	Az

* In NCR-LEGACY mode the Code-ID transmits a P.

RS-232 Host Types

To select an RS-232 host interface, scan one of the following barcodes.

- ✓ **NOTES**
1. Scanning **Standard RS-232** activates the RS-232 driver, but does not change port settings (e.g., parity, data bits, handshaking). Selecting another RS-232 host type barcode changes these settings.
 2. The CUTE host disables all parameter scanning, including Set Defaults. If you inadvertently select CUTE, scan **Enable Parameter Barcode Scanning** (located in the *MP7000 Scanner Scale Barcode Programming Guide*) then change the host selection.

Options:

- *Standard RS-232 (default)
- ICL RS-232
- Wincor-Nixdorf RS-232 Mode A
- Wincor-Nixdorf RS-232 Mode B
- Olivetti ORS4500
- Omron
- OPOS/JPOS
- Fujitsu RS-232
- CUTE
- NCR Variant (both scanner only and scanner/scale versions)
- Datalogic Variant.

RS-232 Host Types (continued)



*Standard RS-232

RS-232 Host Types (continued)

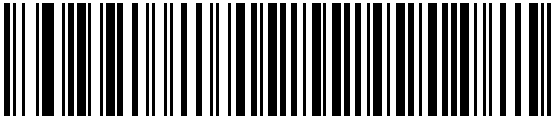

ICL RS-232

RS-232 Host Types (continued)

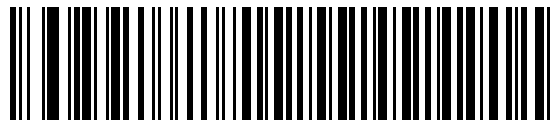

Wincor-Nixdorf RS-232 Mode A

RS-232 Host Types (continued)



Wincor-Nixdorf RS-232 Mode B

RS-232 Host Types (continued)



Olivetti ORS450

RS-232 Host Types (continued)

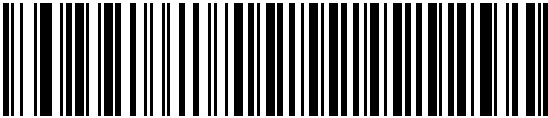

Omron

RS-232 Host Types (continued)



OPOS/JPOS

RS-232 Host Types (continued)



Fujitsu RS-232

RS-232 Host Types (continued)



CUTE²

RS-232 Host Types (continued)

RS-232 Host -NCR Variant

Scan the barcode below to enable the NCR variant of the RS-232 host.



IMPORTANT There are several parameter options available with the NCR variant for RS-232. Refer to the *MP7000 Scanner Scale Barcode Programming Guide (p/n MN-002912-xx)* to manage the following NCR related parameters:

- NCR Use Prefix
- NCR Prefix
- NCR Suffix
- NCR Use BCC
- NCR Interface.

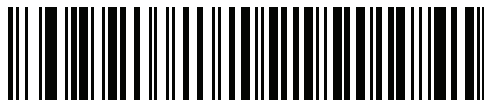

NCR Variant

RS-232 Host Types (continued)

RS-232 Host -Datalogic Variant

Scan the barcode below to enable the Datalogic variant of the RS-232 host.

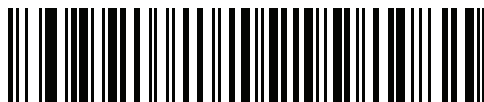

Datalogic Variant

RS-232 Device Port Configuration

Parameter # 1246

SSI # F8h 04h DEh

This option allows the user to select which devices to attach to the MP7X00, and to which port they are attached. Scan the appropriate barcodes that follow to select the proper configuration.

The available configurations/options are:

- *0 = Aux 1 Sensormatic, and Aux 2 Scanner
- 1 = Aux 1 Dual Cable Scale, and Aux 2 Scanner
- 2 = Aux 1 Sensormatic, and Aux 2 Dual Cable Scale
- 4 = Aux 1 Third Party Scale, Aux 2 Sensormatic
- 5 = Aux 1 Sensormatic, and Aux 2 Disabled
- 6 = Aux 1 Dual Cable Scale, and Aux 2 Disabled
- 7 = Aux 1 Third Party Scale, and Aux 2 Disabled
- 8 = Aux 1 Disabled, and Aux 2 Scanner
- 9 = Aux 1 Disabled, and Aux 2 Dual Cable Scale
- 10 = Aux 1 Disabled, and Aux 2 Sensormatic
- 11 = Aux 1 Disabled, and Aux 2 Disabled

Changes to this parameter do not take effect until the next power cycle (power cycling does not apply to 123Scan). For that reason always remember to perform one of the functions below after scanning a device port parameter.

- Cycle power to the scanner (disconnect, and re-connect scanner cable).
- or
- Use the MP7X00 **Reset** button (a button combination to reboot the MP7X00).

When selecting any of the device port configuration options, ensure the devices connected to the MP7X00 correctly match the devices defined for the option. For example, if option 1 is scanned, only a dual cable scale should be connected to the Aux 1 port, and an RS-232 scanner should be connected to the Aux 2 port. Turning on the MP7X00 with connected devices that do not match the option can result in communication failures. To ensure successful operation the proper sequence for setting this option is as follows.

1. Power off the MP7X00 (disconnect the power cable).
2. Disconnect all RS-232 devices (RS-232 scanner, Sensormatic, and/or dual cable scale).
3. Power on the MP7X00 (reconnect the power cable).
4. Scan the appropriate barcode option that matches the intended configuration.
5. Power off the MP7X00.
6. Connect the appropriate devices.
7. Power on the MP7X00.

Table 2-9 *Device Specific Default Values (Inherited Defaults)*

Device	Baud	Data Bits	Stop Bits	Parity
Scanner	9600	8	1	None
Sensormatic	9600	8	1	None
Dual Cable Scale: SASI Protocol	9600	7	1	Even
Dual Cable Scale: DIGI Protocol	9600	7	2	Even
Dual Cable Scale: ICL Protocol	9600	7	1	Even
Third Party Scale	NA	NA	NA	NA

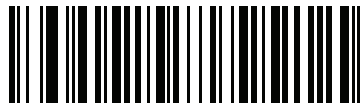

***Aux 1 Sensormatic and Aux 2 Scanner
(00h)**

RS-232 Device Port Configuration (continued)



**Aux 1 Dual Cable Scale and Aux 2 Scanner
(01h)**

RS-232 Device Port Configuration (continued)



**Aux 1 Sensormatic and Aux 2 Dual Cable Scale
(02h)**

RS-232 Device Port Configuration (continued)



**Aux 1 Third Party Scale, Aux 2 Sensormatic
(04h)**

RS-232 Device Port Configuration (continued)



**Aux 1 Sensormatic, and Aux 2 Disabled
(05h)**

RS-232 Device Port Configuration (continued)



**Aux 1 Dual Cable Scale, and Aux 2 Disabled
(06h)**

RS-232 Device Port Configuration (continued)



**Aux 1 Third Party Scale, and Aux 2 Disabled
(07h)**

RS-232 Device Port Configuration (continued)



**Aux 1 Disabled, and Aux 2 Scanner
(08h)**

RS-232 Device Port Configuration (continued)



**Aux 1 Disabled, and Aux 2 Dual Cable Scale
(09h)**

RS-232 Device Port Configuration (continued)



**Aux 1 Disabled, and Aux 2 Sensormatic
(010h)**

RS-232 Device Port Configuration (continued)



**Aux 1 Disabled, and Aux 2 Disabled
(011h)**

Third Party Scale Parameters

Third Party Scale

Parameter # 1294

Enable or disable **Third Party Scale** functionality. When disabled **Third Party Scale LED Pin** (parameter # 1295) and **Third Party Scale Zero Pin** (parameter # 1296) are ignored/overridden. (Also see [Price Computational Scale Interface Circuit Drawing on page 2-14.](#))

Options:

- Enable Third Party Scale
- *Disable Third Party Scale.



Enable Third Party Scale
(1)

Third Party Scale (continued)

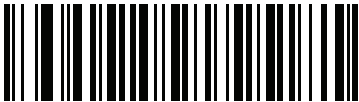

*** Disable Third Party Scale
(0)**

Third Party Scale LED Pin

Parameter # 1295

This parameter defines the polarity of the LED/Tare input pin that illuminates the scale LED. This parameter has no effect if **Third Party Scale** (parameter # 1294) is disabled.



Active Low
(0)

Third Party Scale LED Pin (continued)

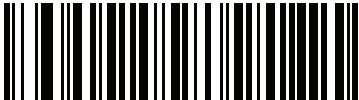

***Active High
(1)**

Third Party Scale Zero Pin

Parameter # 1296

This parameter defines the polarity of the zero output pin when the **Scale Zero** button is pressed. This parameter has no effect if **Third Party Scale** (parameter # 1294) is disabled.



Active Low
(0)

Third Party Scale Zero Pin (continued)



***Active High
(1)**

IBM RS-485 Interface

Connecting

- ✓ **NOTE** For a list of supported scanner functionality by communication protocol [Appendix E, Communication Protocol Functionality](#).

Connect the MP70XX directly to the host interface.

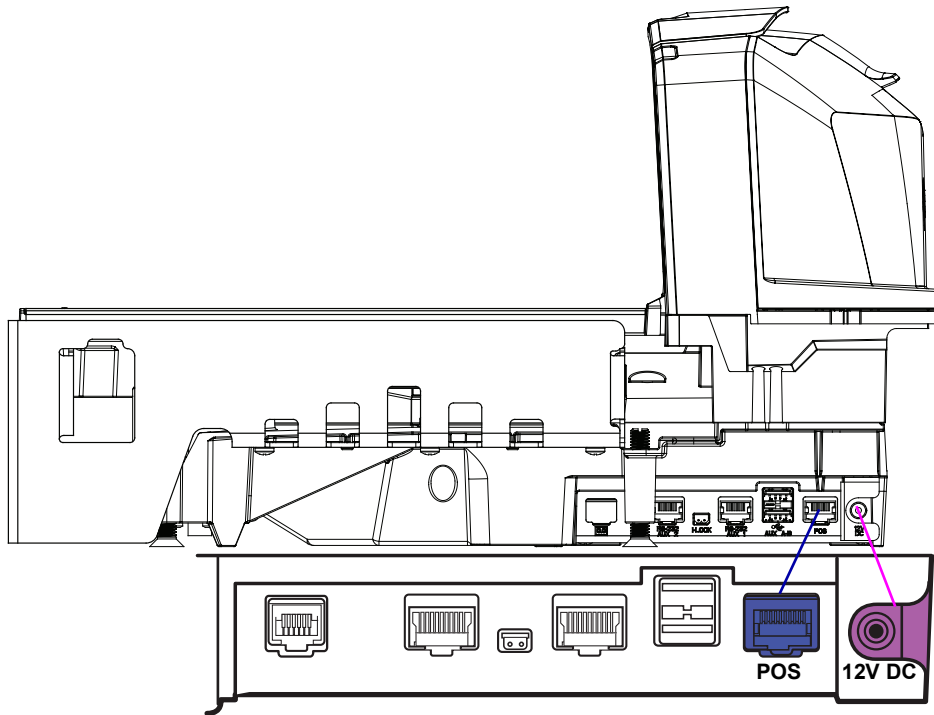

Figure 2-4 IBM RS-485 Connections

To set up the MP70XX:

1. Attach the modular connector of the IBM RS-485 interface cable to the POS interface port on the MP70XX.
2. Connect the other end of the IBM RS-485 interface cable to the appropriate port on the host (typically Port 9). The unit should power up immediately upon connection. If not, wait for unit to power up.

- ✓ **NOTE** Older POS systems, and/or some retailers will require use of the external power supply PWR-BGA12V50W0WW.

3. Select the port address by scanning the appropriate barcode (refer to *MP7000 Scanner Scale Barcode Programming Guide*, p/n MN-002912-xx).
4. If a scale is present in the unit, scan the appropriate scale port address ([IBM Scale Port Addresses on page 2-58](#)).
5. To modify any other parameter options, scan the appropriate barcodes in the *MP7000 Scanner Scale Barcode Programming Guide* (p/n MN-002912-xx).

- ✓ **NOTE** The only required configurations are the port addresses (IBM RS-485 port address, and a scale port address if the model has a scale), and type directives (see [Step 6](#)). The IBM system typically controls other MP70XX parameters.

6. To prevent the IBM POS from configuring the MP70XX, refer to the *MP7000 Scanner Scale Barcode Programming Guide* for information about RS-485 and IBM USB configuration, beep, scale, and type directives.

IBM RS-485 Host Parameters



IMPORTANT This chapter includes port address parameters only. For additional user preferences (including IBM Directives, refer to the *MP7000 Scanner Scale Barcode Programming Guide* (p/n MN-002912-xx).

To select the IBM RS-485 port used, scan one of the barcodes listed in [Table 2-10](#).

- ✓ **NOTE** 1. Scanning one of these barcodes enables the RS-485 interface on the MP70XX.
2. The port numbers in [Table 2-10](#) are no longer physical ports on the IBM POS.

- ✓ **NOTE** This guide includes limited parameter barcodes. For ALL MP70XX programming barcodes, refer to the *MP7000 Scanner Scale Barcode Programming Guide* (p/n MN-002912-xx).

Table 2-10 IBM RS-485 Port Parameters

Parameter	Page Number
IBM Port Addresses	
None Selected (default)	2-54
Hand-held Scanner Emulation (Port 9B)	2-55
Non-IBM Scanner Emulation (Port 5B)	2-56
Table-top Scanner Emulation (Port 17)	2-57
IBM Scale Port Addresses	
None Selected (default)	2-58
Port 6A	2-59
Port 6B	2-60
Port 6E	2-61

IBM Port Addresses



*None Selected

IBM Port Addresses (continued)



Hand-held Scanner Emulation (Port 9B)

IBM Port Addresses (continued)



Non-IBM Scanner Emulation (Port 5B)

IBM Port Addresses (continued)



Tabletop Scanner Emulation (Port 17)

IBM Scale Port Addresses

The scale port address must be configured for the scale to operate on the IBM RS-485 bus. The default is **None Selected**.



*None Selected

IBM Scale Port Addresses (continued)



Port 6A

IBM Scale Port Addresses (continued)



Port 6B

IBM Scale Port Addresses (continued)



Port 6E

Connector Pins

RS-232 AUX 1

Table 2-11 RJ-45

Pin #	Signal/Name	Direction	Description
1	N/C	N/A	No Connection
2	5V	Out	RS-232 scanner 5VDC Supply*
3	GND	N/A	Signal Ground
4	TXD	Out	Serial TXD ($\pm 5.4V$)
5	RXD	In	Serial RXD ($\pm 5.4V$)
6	RTS	Out	Serial RTS ($\pm 5.4V$)
7	CTS	In	Serial CTS ($\pm 5.4V$)
8	Scale LED	In	Indicates price computational scale has returned to zero - reflected in UI Scale Status LED (if enabled). I/O signals are 5V TTL.
9	Scale Zero	Out	Zeros price computational scale when the Zero UI button is pressed (if enabled). I/O signals are 5V TTL.
10	12V/150mA	Out	Power output for price computational scale.

Scale Display Port

Table 2-12 RJ-11, Scale Display

Pin #	Signal/Name	Direction	Description
1	DEBUG_TXD	Out	Debug serial TX
2	5V	Out	Auxiliary 5V output *
3	TXD	Out	Scale Display serial TX (3.3V TTL)
4	RXD	In	Scale Display serial RX (3.3V TTL)
5	GND	N/A	Signal ground
6	DEBUG_RXD	In	Debug serial RX

* The total combined current for the USB and RS-232 peripheral ports should be less than 750mA total auxiliary current. Each individual port should not exceed 500mA.

RS-232 AUX 2

Table 2-13 RJ-45

Pin #	Signal/Name	Direction	Description
1	N/C	N/A	No connection
2	5V	Out	RS-232 scanner 5V supply *
3	GND	N/A	Signal ground
4	TXD	Out	Serial TXD ($\pm 5.4V$)
5	RXD	In	Serial RXD ($\pm 5.4V$)
6	RTS	Out	Serial RTS ($\pm 5.4V$)
7	CTS	In	Serial CTS ($\pm 5.4V$)
8	N/C	N/A	No connection
9	N/C	N/A	No connection
10	12V/150mA	Out	Output for auxiliary device. NOTE 150mA maximum available between both AUX 1 and AUX 2.

*The total combined current for the USB and RS-232 peripheral ports should be less than 750mA total auxiliary current. Each individual port should not exceed 500mA.

Checkpoint Interlock

Table 2-14 EAS Interlock Connector

Pin #	Signal/Name	Direction	Description
1	Interlock	Out	Checkpoint EAS Interlock (5V 4mA PNP collector out)
2	GND	N/A	Signal ground

AUX A-B (Stacked USB)

- ✓ **NOTE** An additional USB port is available in the front under the platter. All USB ports can be used for the USB staging flash drive. See [Table 1-3 on page 1-16](#) and [USB Staging Flash Drive on page 5-10](#) for additional information.

Table 2-15 *Stacked USB Port*

Pin #	Signal/Name	Direction	Description
1	5V	Out	USB 5V output *
2	D-	Bidirectional	USB D-
3	D+	Bidirectional	USB D+
4	GND	N/A	Signal ground

*The total combined current for the USB and RS-232 peripheral ports should be less than 750mA total auxiliary current. Each individual port should not exceed 500mA.

POS

Table 2-16 *RJ-45, Primary POS*

Pin #	Signal/Name	Direction	Description
1	DETECT	Out	USB cable detect output
2	5V	In	USB cable 5V detect input
3	GND	N/A	Signal ground
4	TXD/IBM-A	Bidirectional	Multiplexed serial TXD/IBM-A
5	RXD/D+	Bidirectional	Multiplexed serial RXD/USB D+
6	RTS/IBM-B	Bidirectional	Multiplexed serial RTS/IBM-B
7	CTS/USB D-	Bidirectional	Multiplexed serial CTS/USB D
8	DOWNLOAD	In	POS download
9	N/C	N/A	No connection
10	12V	In	Terminal 12VDC to MP70XX (Power From Terminal) *

*Terminal systems vary in power capabilities. Ensure your system power supply is capable of the MP70XX configuration power requirements. For terminals unable to support P.O.T., a 12V DC barrel jack is available for external power.

12V DC**Table 2-17** *12V DC Jack, 2.5mm*

Pin #	Signal/Name	Direction	Description
1	EXT 12V	In	Center pin: 12VDC (primary power)
2	GND	N/A	Barrel: signal ground

CHAPTER 3 SITE PREPARATION AND INSTALLATION

Introduction

The MP7000 Scanner Scale was designed to drop into an existing bioptic checkstand cutout with no modifications. The unit is available in three industry standard sizes (for more detailed information, see [Appendix B, Technical Specifications](#)):

- Short - no scale available
Length: 13.9 in. (351.0 mm)
Width: 11.5 in. (292.0 mm)
- Medium - with or without scale
Length: 15.7 in. (398.0 mm)
Width: 11.5 in. (292.0 mm)
- Long - with or without scale
Length: 20.0 in. (506.0 mm)
Width: 11.5 in. (292.0 mm)

Site Preparation



IMPORTANT This guide does not encompass all factors related to worker safety and check stand design. It does offer a list of considerations which may be helpful in ensuring greater safety and productivity.

Ventilation and Spacing Requirements

The scanner/scale housing was designed to provide adequate space for ventilation and drainage for spills. [Figure 3-7](#) shows the drainage holes, under the platter, for possible spills that may occur when scanning/weighing items.

Checkstand ventilation may be required to ensure the MP70XX temperature limits are not exceeded. If forced air ventilation is used, it must not pass through the MP70XX as this can produce an unstable weighing environment. The ambient air temperature inside the checkstand, adjacent to the device, must not exceed 104°F (40°C).

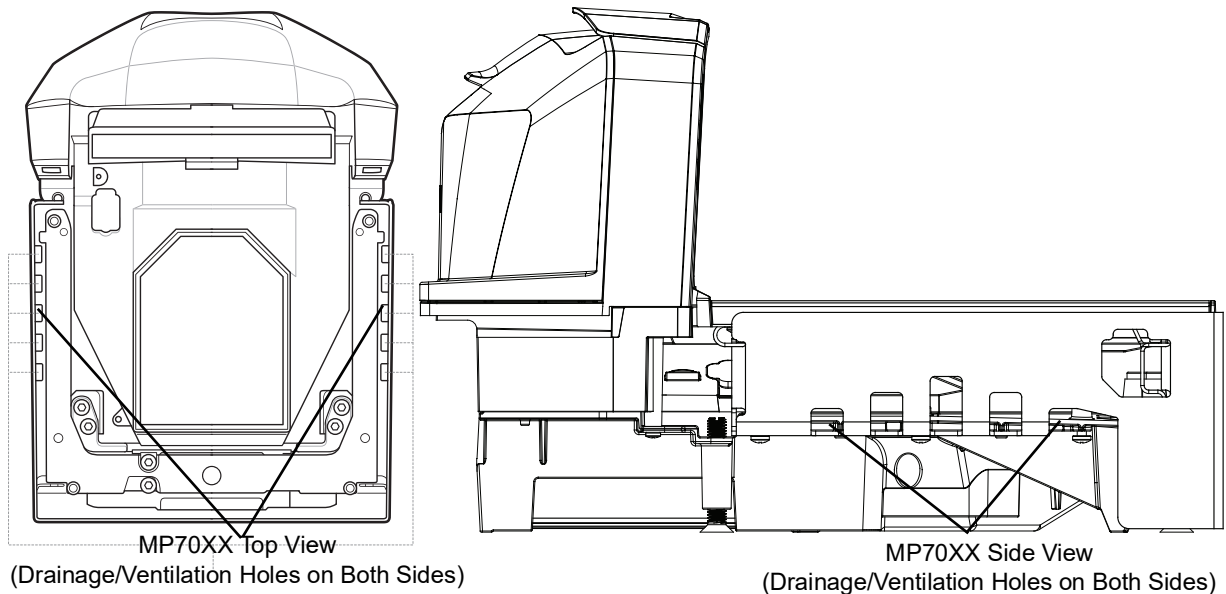

Figure 3-1 *Drainage/Ventilation Holes*

Service Access Requirements

The MP70XX was engineered to allow performance of all routine service and maintenance (including scale zeroing, and calibration) without removing the scanner from the counter.

Service must be performed by a Zebra Certified Repair Provider who has completed the Service Repair Training course, and (if applicable) the Scale Calibration Training course. For MP7001 and MP7002 scanner/scales, depending on the region of installation, a certified Weights & Measures technician is required to place the device *in trade* before using, and after certain repairs.

Electrical Power Considerations

The MP70XX may be powered from two different sources:

- POS Equipment
 - IBM register with powered Port 9B interface (using p/n CBA-M51-S16PAR accessory cable)
 - Any register with powered USB interface - 12V only (using p/n CBA-U52-S16PAR accessory cable).
- AC/DC power cube (p/n PWR-BGA12V50W0WW), country specific IEC Line Cord, DC Power Cord (p/n CBL-DC-388A1-01).

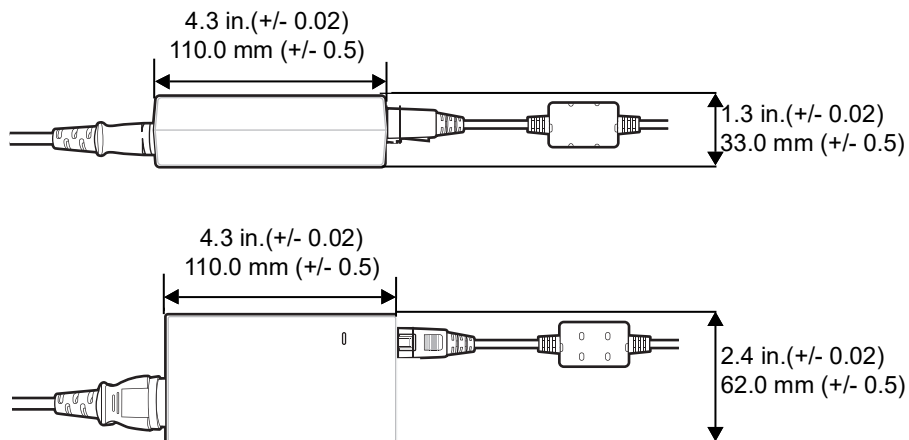

Figure 3-2 Power Supply

If using the AC/DC accessory power supply, a 115V/230V outlet must be available in the checkstand near the scanner.

Grounding

All POS equipment should be properly grounded, and only a three prong IEC style line cord should be used with the AC/DC accessory power supply.

If you are unsure how to verify proper ground of equipment in the checkstand ask a qualified electrician to review the equipment installation.

- ✓ **NOTE** In an effort to eliminate a possible safety hazard all metal parts of a metal checkstand must be electrically grounded.

Checkstand Preparation

If the MP70XX is not replacing an old bioptic device, and you are installing for the first time into a new checkstand, verify that the area allows for proper cabling, and an AC/DC power supply. Mounting may require installation of support(s), leveling screws, and peripheral devices. See [Counter Cutout on page 3-5](#) for more details about the location and preparation of the opening.

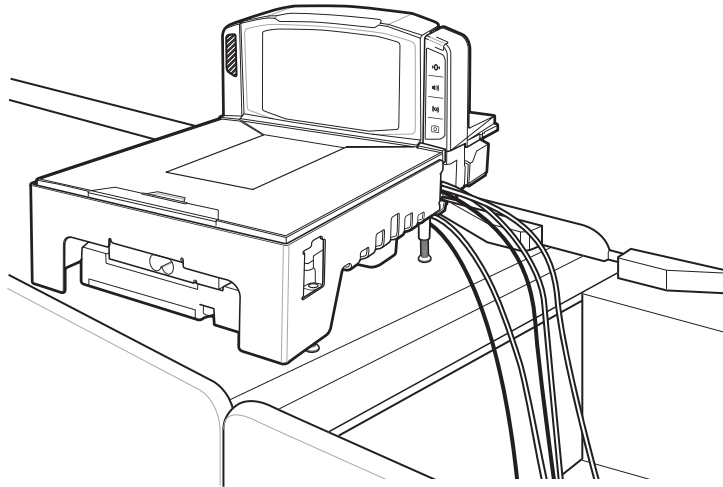

Figure 3-3 *Preparing the Checkstand*



IMPORTANT

The long MP70XX models (20.0 in./50.6 cm) are not available with leveling screws. For the medium (15.7 in./39.8 cm) and short (13.9 in./35.1 cm) MP70XX models the checkstand should provide for two leveling screws under the front and rear of the MP70XX.

Leveling screws accessory kit MX301-SR00004ZZWR is shipped with every short and medium model. Longer leveling screws with a 1 in. (25 mm) extra length are available for purchase, if required (accessory kit p/n MX302-SR00004ZZWR).

Liquid Spills and Moisture

Select a checkstand design which allows fluids to flow through, and directs liquids and moisture build up away from any electronic equipment or storage areas. Should a liquid spill occur, ensure that moisture can flow through the checkstand without pooling. The power supply should be away from any area where spills may occur.

Vertical Clearance

For all configurations of the MP70XX, the maximum height above the platter is 5.1 in (129.5 mm); the maximum depth below the platter is 4.08 in.

Tools

No tools are required to install a MP70XX without a scale or a Checkpoint antenna. The following tools are required to mount the Scale Display:

- Ruler (or similar measuring device)
- Pencil (or similar measuring device)
- Drill
- 2.4 mm (3/32 in.) diameter drill bit (to make screw holes where display is to be mounted)
- 19 mm (3/4 in.) diameter drill bit (to make cable pass through hole where display is to be mounted)
- #2 Phillips screwdriver.

If leveling screws are used on a small or medium MP70XX, a Phillips or flat blade screwdriver is needed.

Counter Cutout

There are three different MP70XX models: long, medium, and short. Prior to cutting the counter opening, ensure you have the dimensions for the scanner/scale being installed (see [Figure 3-10](#), [Figure 3-14](#), and [Figure 3-18](#)). The counter cutout size should reflect the model (also see [page 3-18](#) for installation information).

Ergonomics

Ensure the installation is designed for maximum comfort, efficiency, safety, and ease of use. Allow items to be directed within easy reach, and a scanning area requiring no lifting or special orientation of items.

Installing Components

The MP70XX can be installed with or without the following options:

- Scale and Scale Display (depending on Weights and Measure regulatory jurisdictions, a Scale Display may be required for units with a scale)
- Checkpoint EAS antenna
- Sensormatic EAS coil antennae and RS-232 cabling
- MX101 (CSS)
- AUX hand-held scanners.

Quick Reference Installation Steps

1. Remove the existing scanner scale, and accessories ([page 3-6](#)).
2. Unpack the MP70XX, and accessories ([page 3-6](#)).
3. Install the Scale Display, if applicable ([page 3-8](#)).
4. Connect the cables ([page 3-11](#)).
5. Install MX101 (CSS), if applicable ([page 3-12](#)).
6. Install the MP70XX/scale in the checkstand ([page 3-12](#)).
7. Lower and level the MP70XX in the checkstand ([page 3-19](#)).
8. Power up the MP70XX ([page 3-20](#)).
9. Calibrate the scale, if applicable (see [Chapter 4, Scale Calibration \(For Models With a Scale\)](#)).
10. Install Sensormatic coil, if applicable ([page 3-21](#)).
11. Install Checkpoint antennas, if applicable ([page 3-23](#)).
12. Install the MP70XX trim kit, if applicable ([page 3-30](#)).

Remove Existing Scanner Scale and Accessories

If you are replacing existing equipment, follow these step to remove the old unit:

1. Ensure the POS is logged off, and the drawer was cleared by the store personnel. This varies by location. Some IT Departments may require the POS to be completely shut down.
2. Unplug the current bioptic scanner from its power supply.
3. Prior to removing cables, make a note of the current cable runs.
4. Remove all cables connected to the bioptic scanner. Do not cut cables if you are using, or selling the old equipment.
5. If applicable, unplug the current hand-held device from its power supply, and disconnect it from the current bioptic scanner/host.
 - a. If reusing the hand-held device, leave its cable runs intact.
 - b. If the hand-held device was attached to the bioptic scanner with an RS-232 cable, a new cable and a new hand-held device configuration is required.
6. If a Sensormatic connection is present, there are two cables to be aware of:
 - a. The large cable to the coils/antennas - disconnect from the current bioptic but leave in place.
 - b. The RS-232 cable to the Sensormatic controller communications port - use its run to assist replacing it.
7. If a Scale Display is present:
 - a. Make a note of how the current display was mounted and determine if the current placement can accommodate the new Scale Display. Adjustments to the layout, and cable run may be required.
 - b. Unplug the old Scale Display power.
 - c. Remove it from the checkstand.
 - d. Remove its cables.
 - e. Remove the Scale Display.
8. Remove the existing bioptic scanner.

Unpacking MP7000 Scanner Scale Equipment

To unpack equipment:

1. Remove all components from their packaging, and check that all parts are present. Each box includes the material listed in [Table 3-1](#). Each of the items listed is contained in separate packaging within the box and is recognizable as a discrete item. Power cables, host to scanner communications cables, and trim filler kit are all sold separately in kits.

Table 3-1 *MP7000 Scanner Scale Box Contents*

Description	Part Number
MP70XX w/o Platter	MP70XX-XXXXM00XX
Platter	Part number not applicable.
Leveling Screws	MX301-SR00004ZZWR. (Leveling screws are included in all short and medium units.)
Regulatory Guide	MN-002939-xx

✓ **NOTE** An optional Scale Display, is available separately for scale models only.

- For added protection during shipment, the MP70XX platter is covered with a tight fitting layer of plastic as shown in *Figure 3-4*. This plastic layer must be removed before placing the unit into service. (In the case of a scale model, just before scale calibration; and, in case of a non-scale model, as the final step of installation)

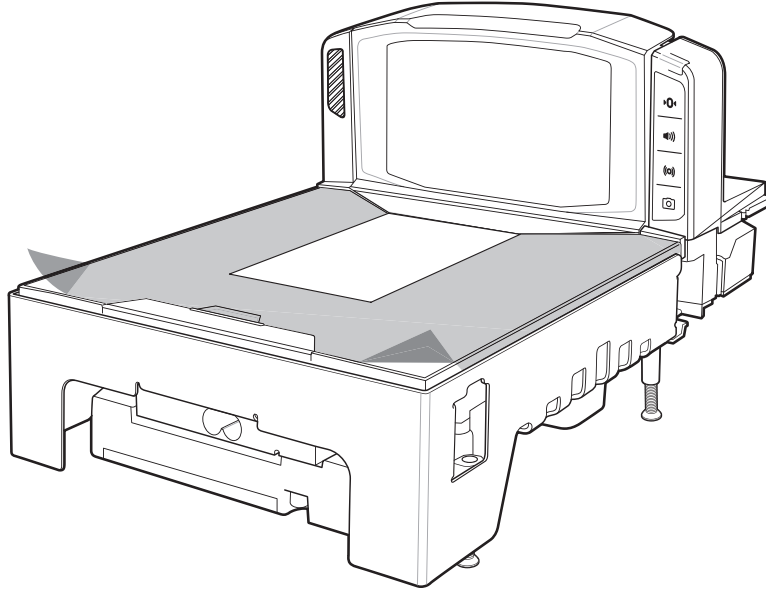

Figure 3-4 *Platter Protector*



CAUTION Do not use a sharp object to remove the protector. Doing so can damage the platter.

- Keep the packing (it is the approved shipping container, and should be used if the MP70XX needs to be returned for servicing), or dispose of the packing in an environmentally sensitive manner.

Pre-Installation Notes

- If a Scale Display is included, it is recommended to mount it in an appropriate location, preferably where the old display was mounted. The cable should be routed through the checkstand.
- If the unit includes a scale, scale calibration is required.
- If the unit includes EAS Sensormatic:
 - its coils require installation
 - the large Sensormatic cable should be threaded from the controller box to the coils
 - The Sensormatic RS-232 cable should be connected to the unit.
- If EAS Checkpoint is required, install the Checkpoint antenna and ensure a Checkpoint representative connects the device to the controller.
- If EAS Checkpoint with interlock is used, connect the interlock cable to the MP70XX.
- All accessories (such as a hand-held scanner, CSS, etc.) require connections.

Install the Scale Display

When installing the optional Scale Display, consider both the cashier and customer's viewing angle. Both must see the weight value displayed.

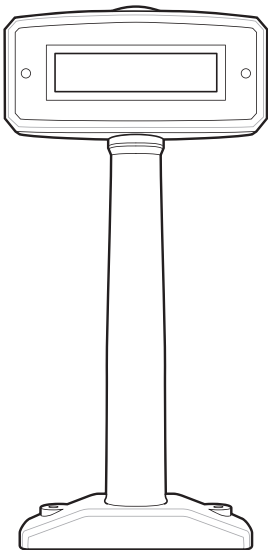
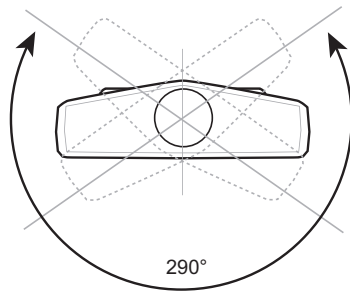

Figure 3-5 *Single Scale Display - Dimensions; Display Rotates Independently (Approximately 290°)*

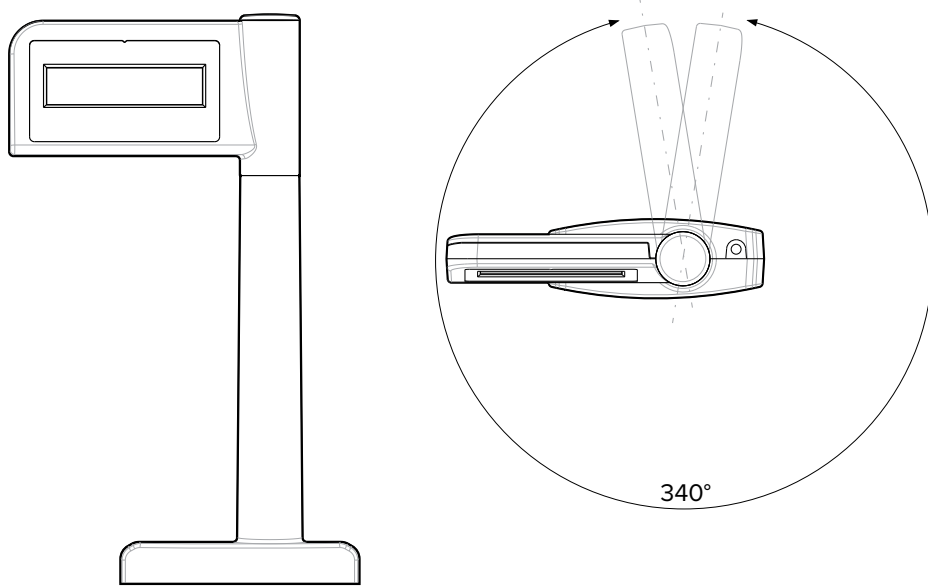

Figure 3-6 Single Head Pole Display - Dimensions; Display Rotates Independently (Approximately 340°)

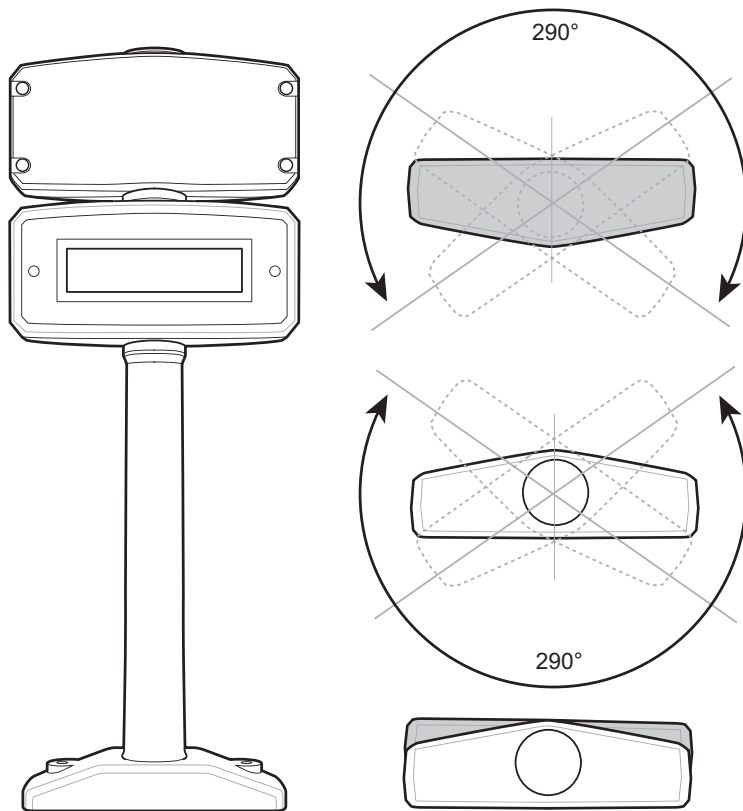

Figure 3-7 Dual Scale Display - Dimensions; Display Rotates Independently (Approximately 290°)

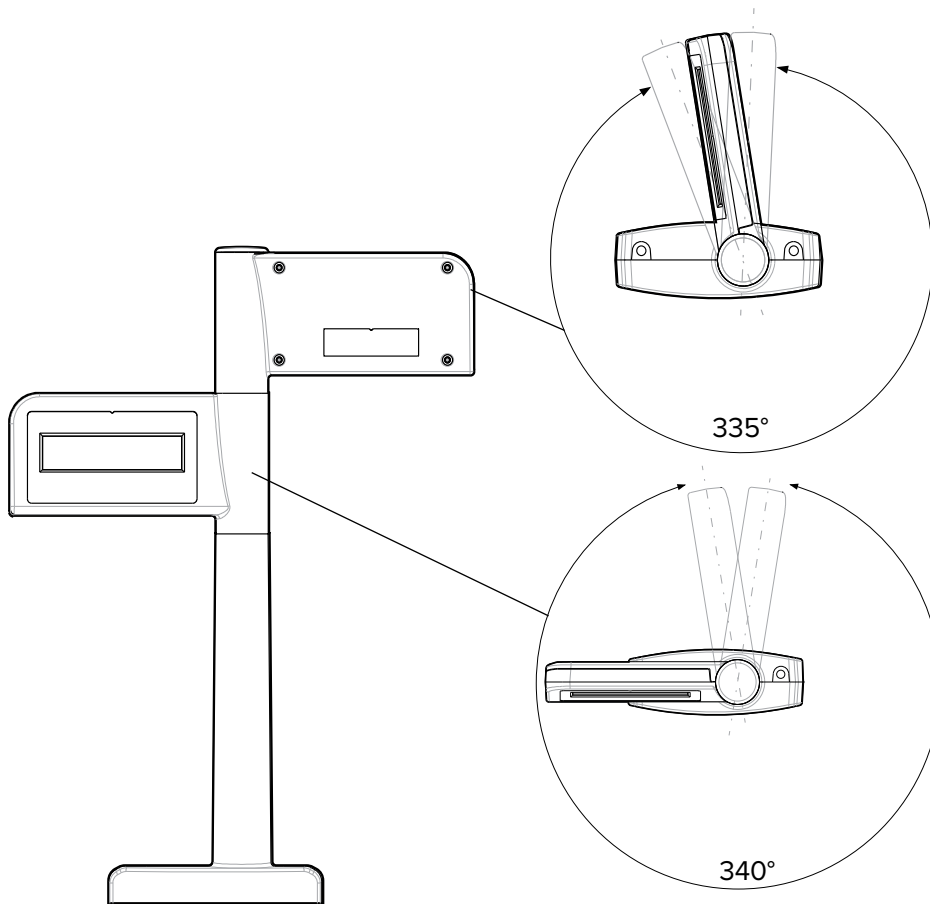

Figure 3-8 *Dual Head Pole Display - Dimensions; Display Rotates Independently (Approximately 335°)*

Getting Started

For an existing Scale Display from an old scanner:

- Unscrew the unit, disconnect its cable from scanner, then remove the unit and cables.
- In same location, (or in a new location as specified by the retailer and/or local weights and measures law) replace with the Zebra Scale Display.

For a new installation:

- Identify the location to install the Scale Display. Identify the location to place the Scale Display based on counter design and viewing angle. Place the unit where it cannot impede access to scanned items being swept over the MP70XX, payment terminals, printer validation and paper roll slots, access to replace consumables (rolls) etc.

✓ **NOTE** BOTH cashier and customer need to see the weight value displayed.

- Drill the required holes where the display is to be mounted.

- a. The 19 mm (3/4 in.) diameter hole is optional, to be used as a through hole for the cable pass-through.



NOTE The cable can also be routed on top of the counter via the notch in the base of the display. See the template for hole spacing.

- b. The other two holes are pilot holes for the mounting screws and should be made to a diameter of 2.4 mm (3/32 in.) and a depth of 25 mm (.98 in.). See the template for hole spacing.

Installing

1. Unpack the new Scale Display from its packaging.
2. Place the proper Scale Display faceplate on the display.
 - a. Fit the correct label on the Scale Display window. Select an overlay to ensure the proper weight units (kg or lb) that are required and parameters EXACTLY match the scale parameters printed on the scale Weights and Measures label. Depending on the unit, and the country location, labels vary. You MUST match the label to the type of MP70XX scale you are installing. (Labels, and instructions for their use, are packaged with the Scale Display.)
 - kg single interval
 - lb single interval
 - kg dual interval
 - kb single interval (with comma) for Brazil
 - b. Remove adhesive backing and carefully secure on the front face of the display.
3. Route the cable through the 19 mm hole in the countertop, or route the cable out through the notch in the base of the display.



NOTE The notch is usually located towards the rear, where it is less visible.

4. Fasten the Scale Display to the countertop.
 - a. Place and align the display over the countertop screw holes.
 - b. Place two screws through each screw hole in the base of the display.
 - c. Drive both screws into the counter until tight.
 - d. Route the cable accordingly and connect the Scale Display cable to port 0.0 Scale Display on the MP70XX BEFORE powering up the scanner/scale (see [Figure 1-3 on page 1-10](#)).
5. Power on the MP70XX. On power up, the Scale Display presents the following test sequence:
 - a. Displays 00.000 for 1.5 seconds; then displays 99.999 for 1.5 seconds.
 - b. Displays *xx.xx0 lb* or *xx.xxx kg* (based on the units selected) in normal operating mode.

Cables and Connections

When routing the power and interface cables for the MP70XX:

- Do not route interface cables in close proximity to electrical motors or other sources of electromagnetic interference.
- Cables can drop directly from their connectors on the scanner, or, alternatively, can be routed along the scanner's side to the back.
- Connect the power cable to the MP70XX before plugging the AC power cord into the AC outlet.

Install the MX101

- ✓ **NOTE** For detailed information about the Customer Side Scanner, refer to the MX101 Customer Side Scanner for the MP7000 Scanner Scale (p/n MN-003031-xx).

The MX101 is an optional modular unit in the MP70XX tower cover that is used for customer side scanning.

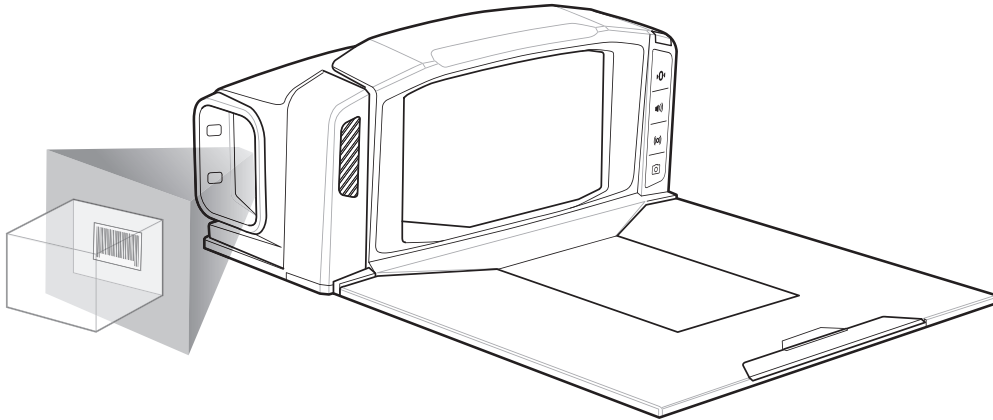

Figure 3-9 *Customer Side Scanning*

Install the MP7000 Scanner Scale

Ensure all components of the MP70XX/scale (if applicable) and cables are ready to install (see [Unpacking MP7000 Scanner Scale Equipment on page 3-6](#)).

Checkstand Counter Cutouts and MP70XX Dimensions

There are three different sets of dimensions for counter cutouts, based on the MP70XX model to install. After cutting the edges they should be clean and straight, with all burrs and splinters removed.

The MP70XX is 11.5 in. wide. If replacing a pre-existing scanner in a checkstand that is 12 in. wide, we recommend a Trim Filler Kit to fill-in the gap in the checkstand (see [Trim Kit Installation \(If Required\) on page 3-30](#)).

The MP70XX is 4 in. deep. If replacing a pre-existing 5 in. deep short or medium scanner, you must use the 1 in. longer leveling screw kit (p/n MX302-SR00004ZZWR). This will bring the platter up to the countertop level.

Cutout/Dimensions - MP70XX Short

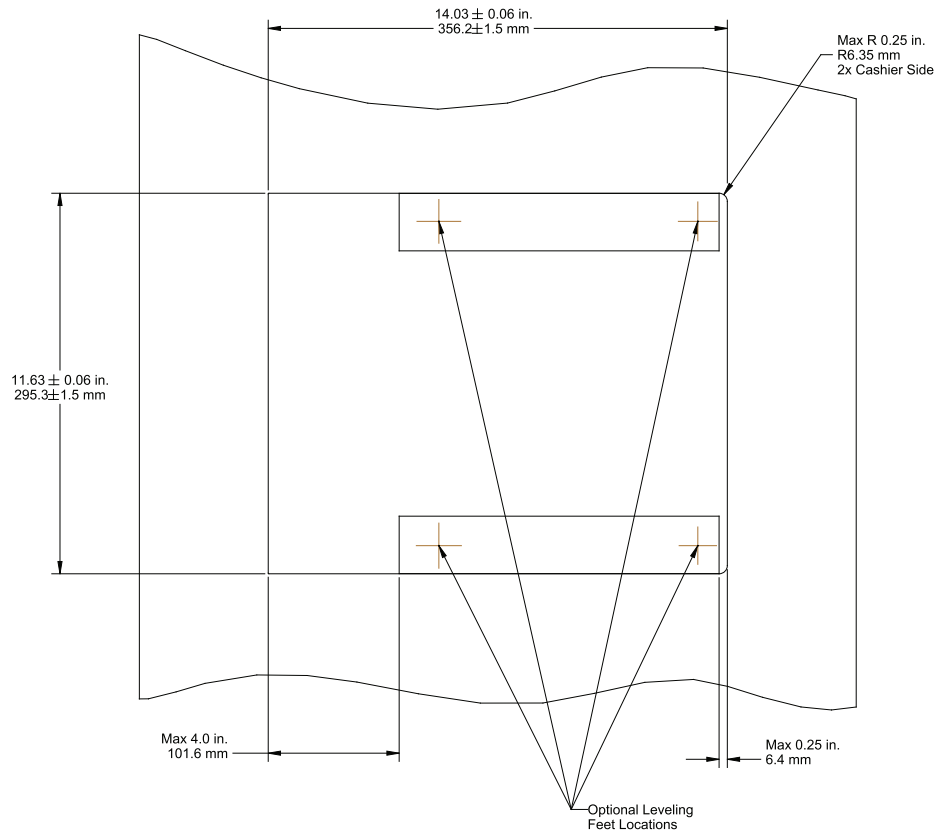

Figure 3-10 Short Unit (No Scale) Counter Cutout

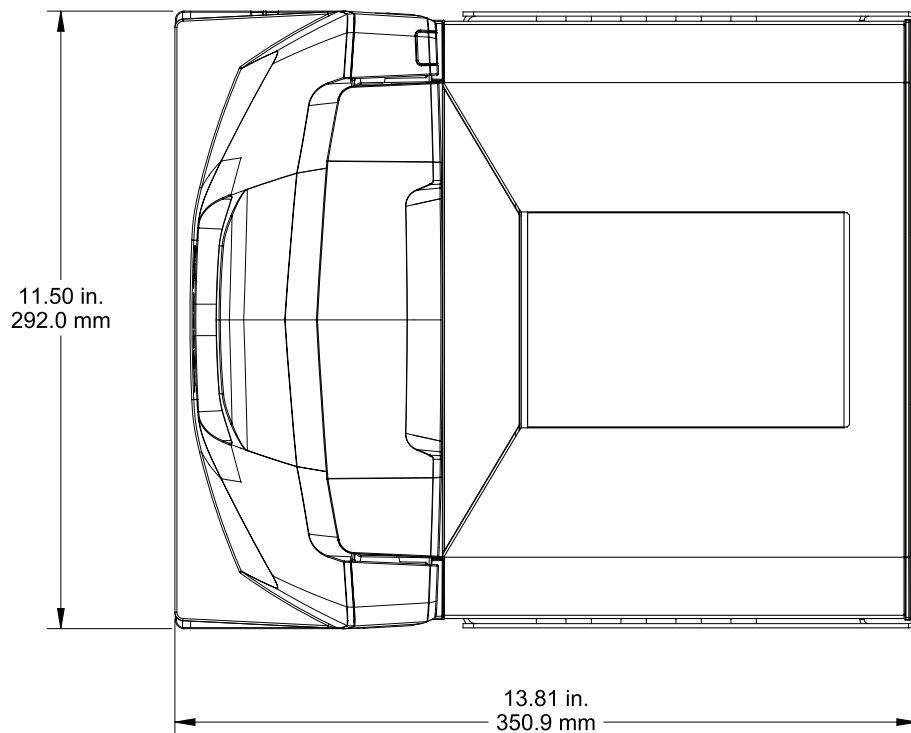

Figure 3-11 Short Unit (No Scale) Top View Dimensions

Cutout/Dimensions - MP70XX Short (continued)

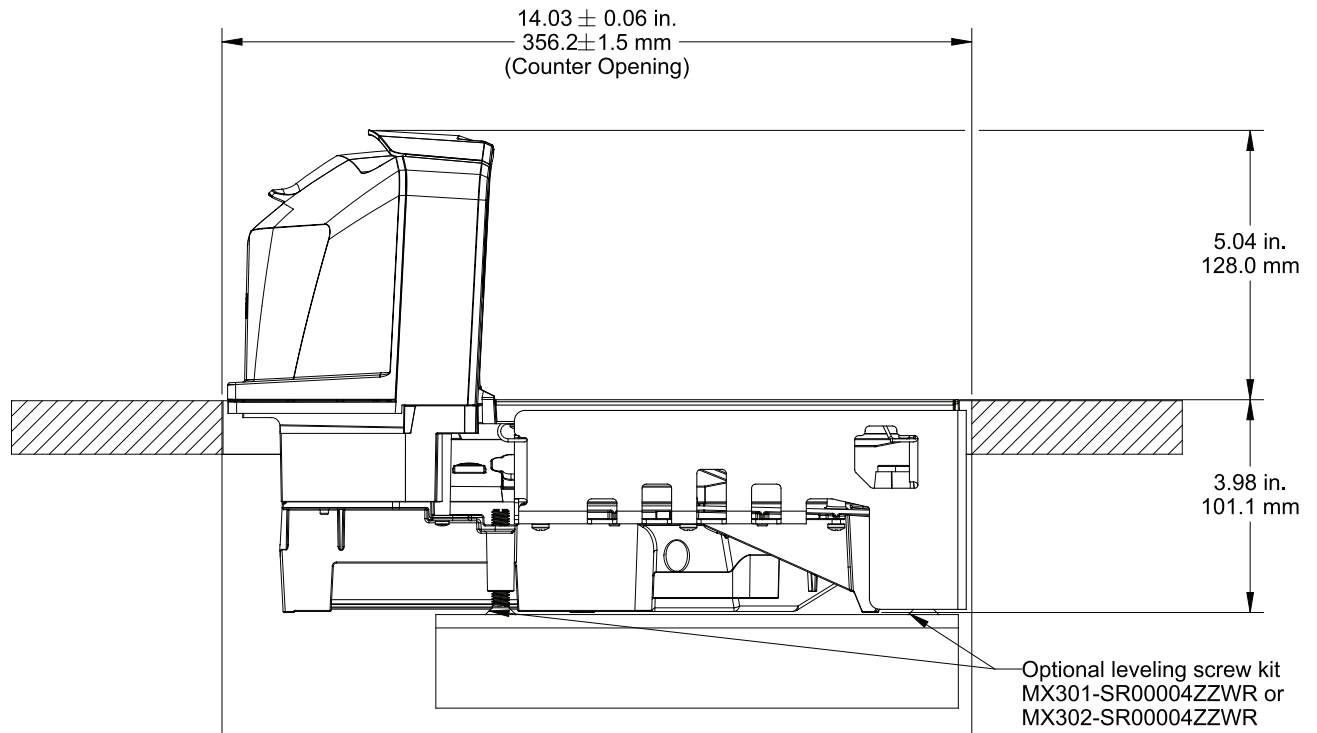

Figure 3-12 Short Unit (No Scale) Side View Dimensions

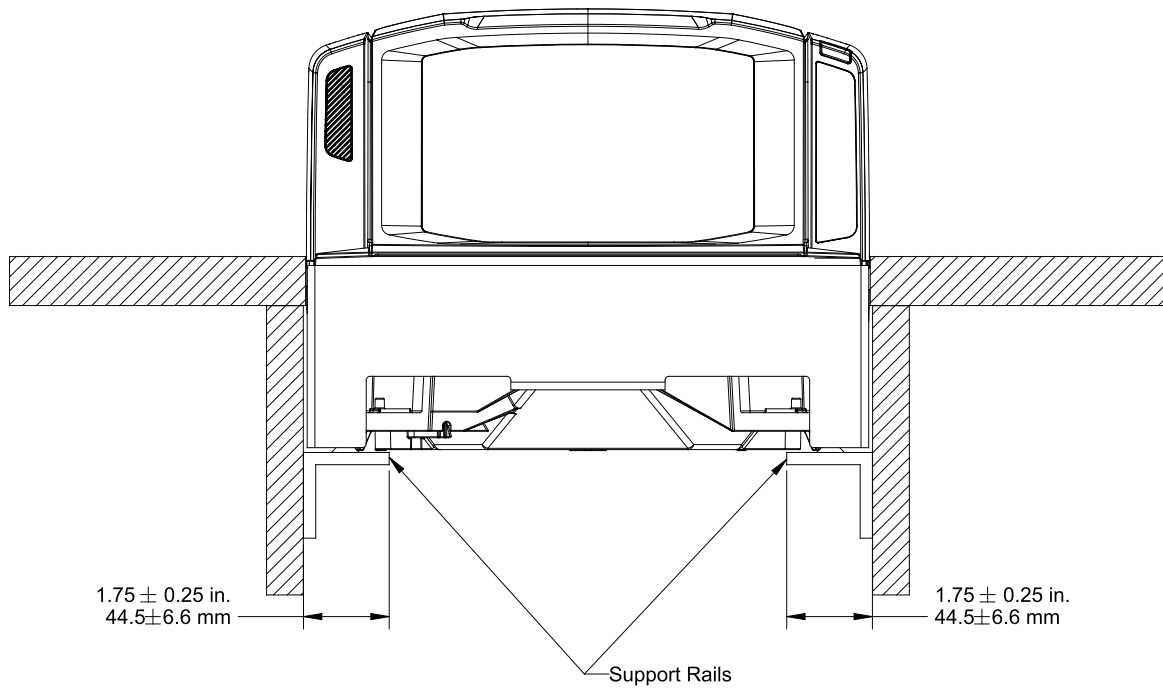

Figure 3-13 Short Unit (No Scale) Front View Dimensions



IMPORTANT Use the support rails as shown, and not a shelf. If liquid spills it pools on a shelf.

Cutout/Dimensions - MP70XX Medium

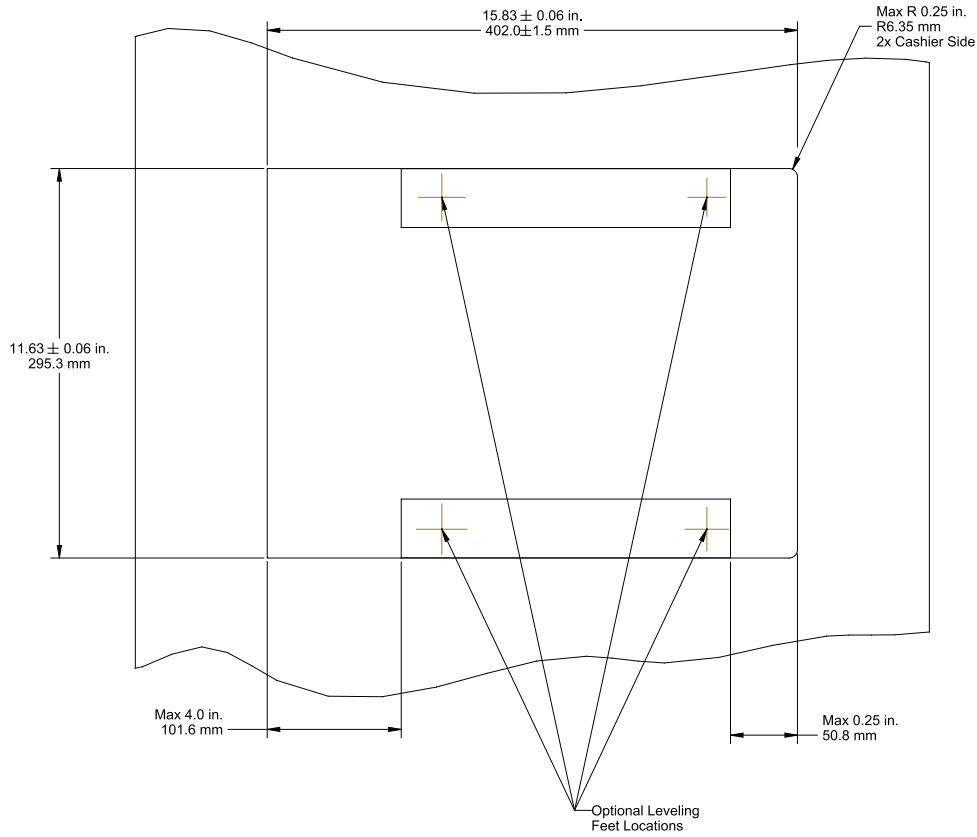

Figure 3-14 Medium Unit Counter Cutout

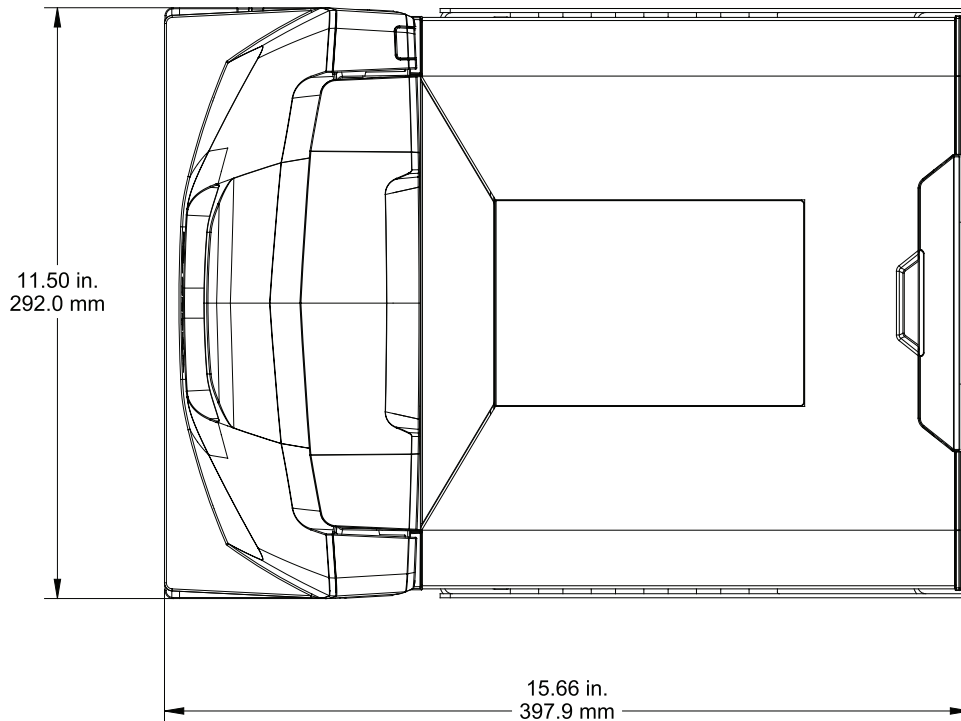

Figure 3-15 Medium Unit Top View Dimensions

Cutout/Dimensions - MP70XX Medium (continued)

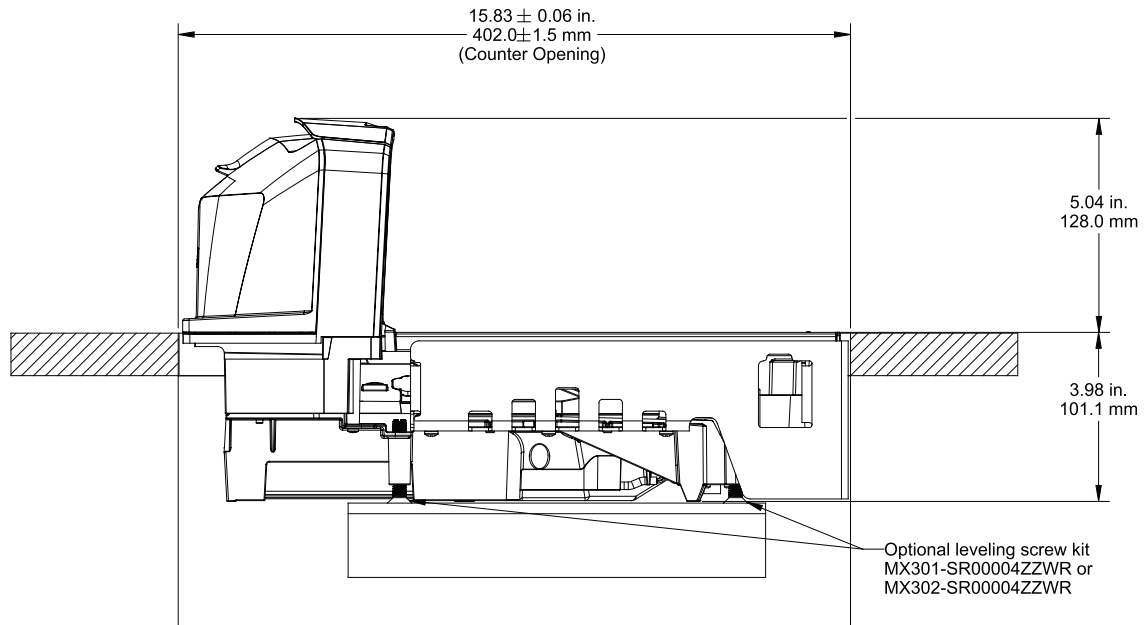

Figure 3-16 Medium Unit Side View Dimensions

- ✓ **NOTE** Leveling screws accessory kit MX301-SR00004ZZWR is shipped with every short and medium model. Longer leveling screws with a 1 in. (25 mm) extra length are available for purchase, if required (accessory kit p/n MX302-SR00004ZZWR).

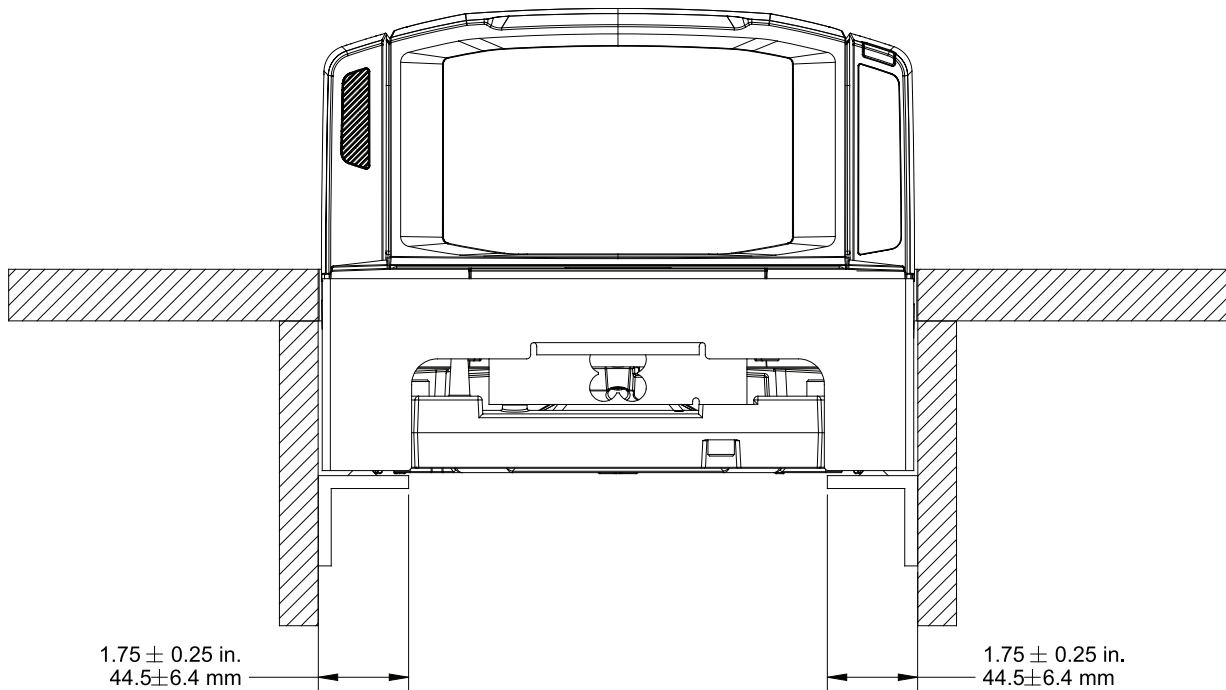

Figure 3-17 Medium Unit Front View Dimensions



IMPORTANT Use the support rails as shown, and not a shelf. If liquid spills it pools on a shelf.

Cutout/Dimensions - MP70XX Long

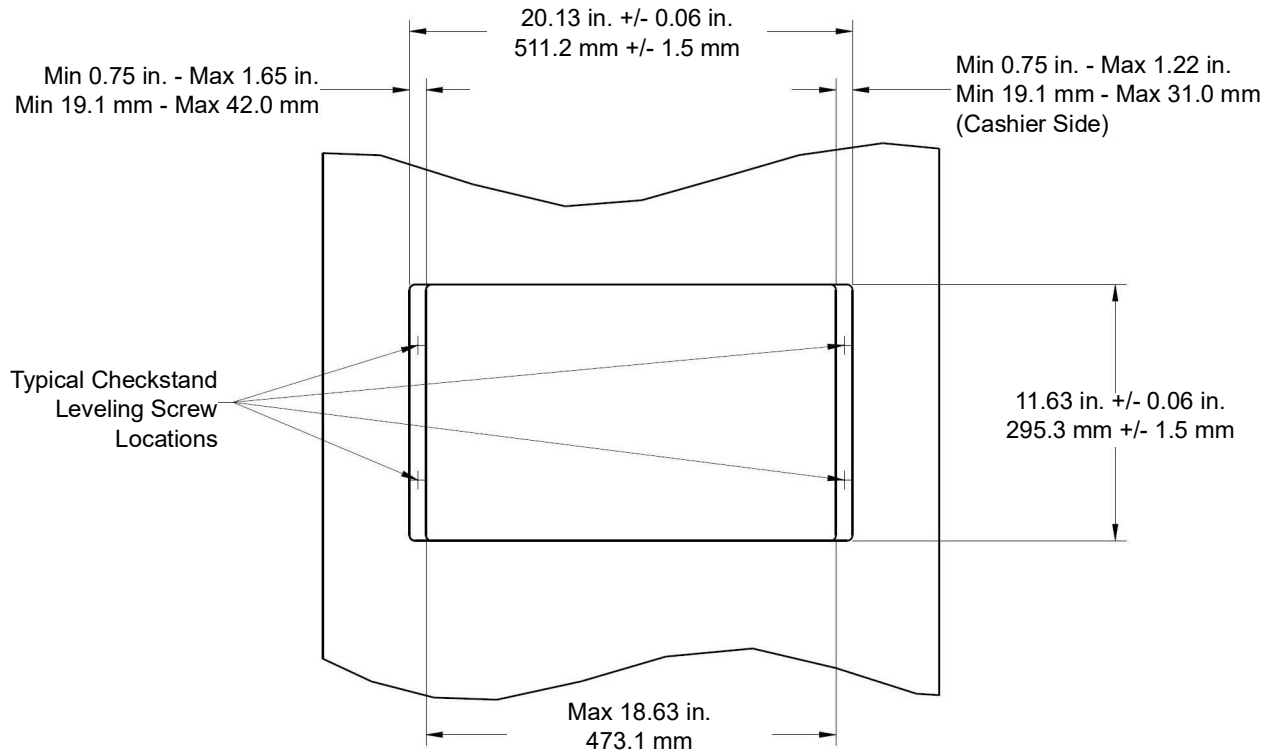

Figure 3-18 Long Unit Counter Cutout

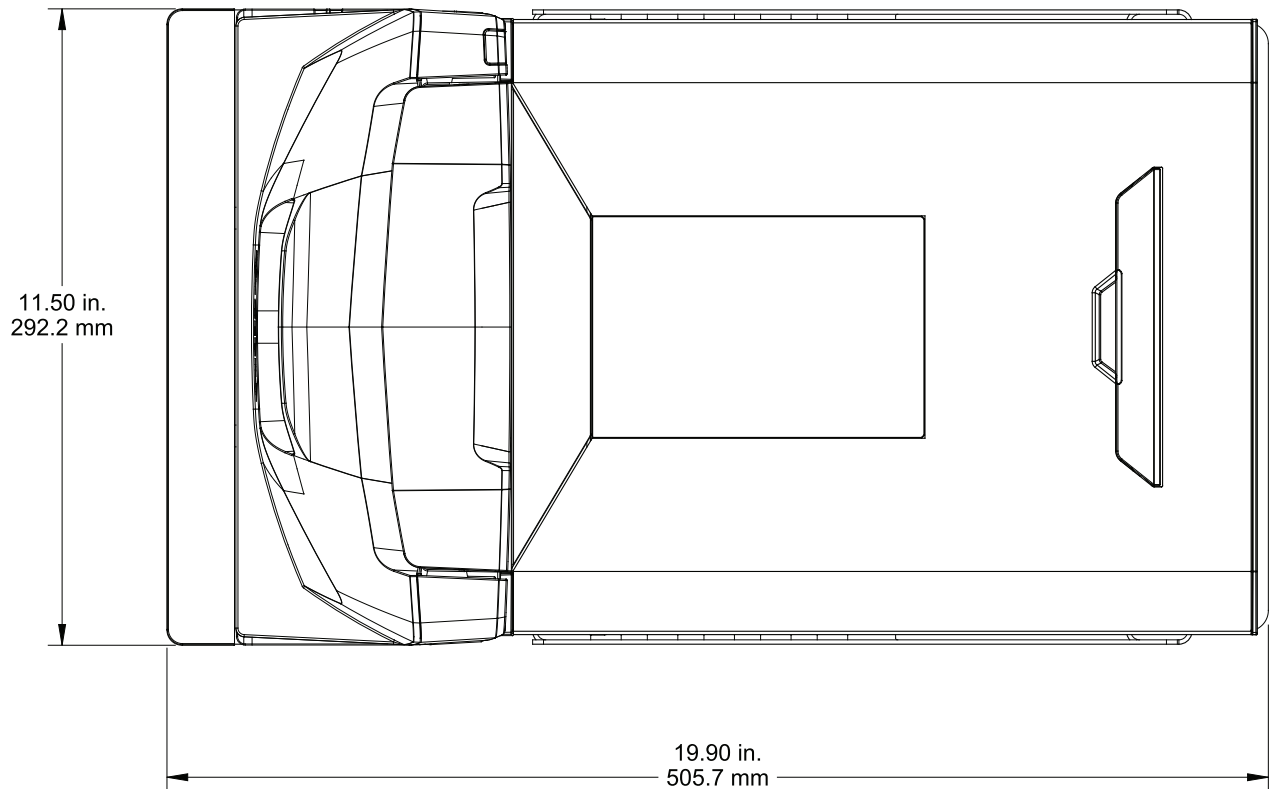

Figure 3-19 Long Unit Top View Dimensions

Cutout/Dimensions - MP70XX Long (continued)

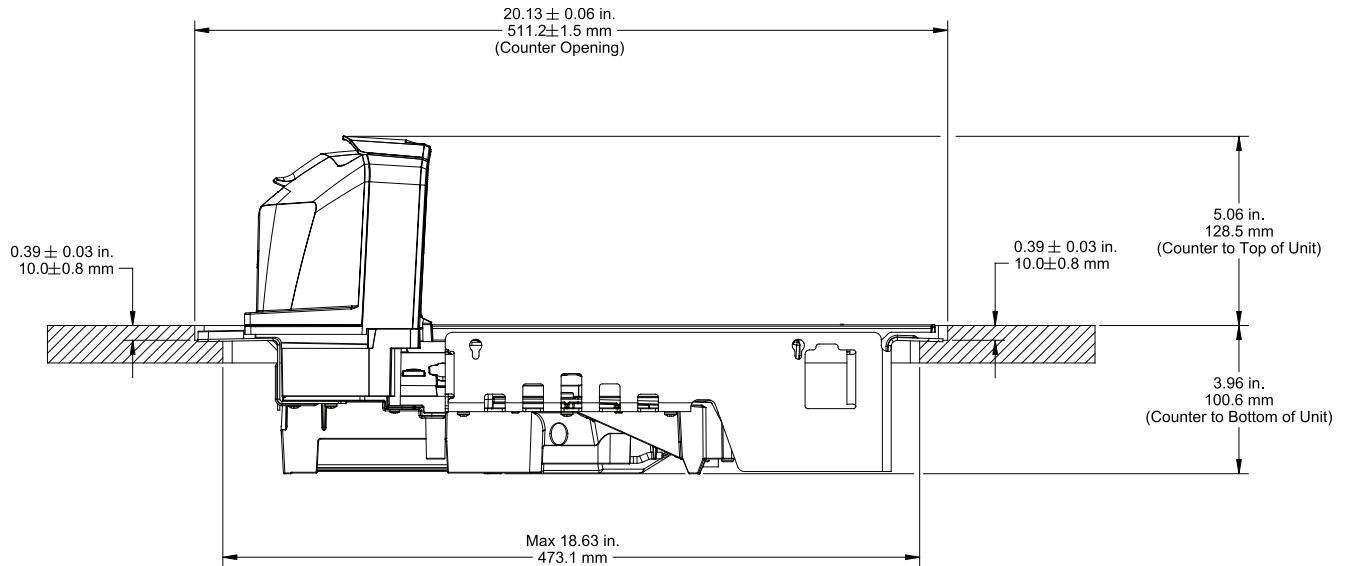

Figure 3-20 Long Unit Side View Dimensions

✓ **NOTE** The countertop, after routing, must have sufficient strength to support the scanner and the loads placed on top of it. If the countertop is not strong enough, add strengthening supports underneath the countertop as required.

To install the MP70XX:

1. Ensure the following items were completed:
 - a. Existing scanner and accessories were removed, if applicable. See [Remove Existing Scanner Scale and Accessories on page 3-6](#).
 - b. Cables were connected and routed. See [Cables and Connections on page 3-11](#).
 - c. The Scale Display was installed, if applicable. See [Install the Scale Display on page 3-8](#).
 - d. CSS was installed, if applicable. See [Install the MX101 on page 3-12](#).
 - e. Sensormatic coil, or Checkpoint EAS antenna was installed, if applicable. See [Install the Sensormatic Coil Antenna on page 3-21](#), or [Install the Checkpoint Antennas on page 3-23](#).
2. Verify checkstand dimensions shown in [Figure 3-10](#), [Figure 3-14](#), and [Figure 3-18](#), respectively.

3. Lower scanner in checkstand as follows.

- a. To grasp the MP70XX to lower it into the checkstand, use the support handle on the back of the tower cover together with the front handle under the platter. See [Figure 3-21 on page 3-19](#).

Short/Medium Units

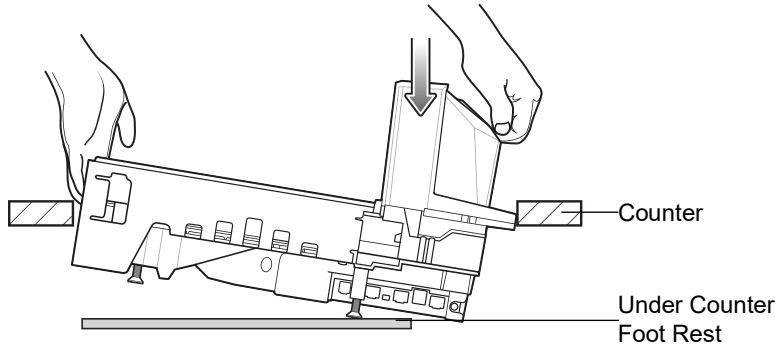

Long Unit

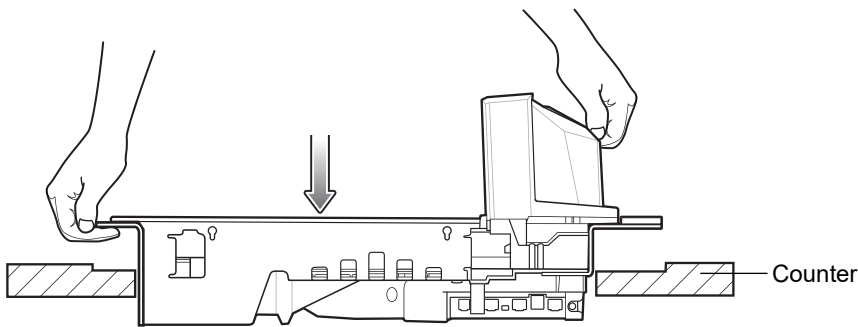

Figure 3-21 Lowering Short, Medium, Long MP70XX into the Counter

- b. Ensure the device is seated properly - see (i) for Long and (ii) for Medium and Short:
 - i. Long MP70XX: The long MP70XX should not rock on the adjustable supports (screws) of the checkstand, and the platter must be flush with the surrounding checkstand. If the MP70XX rocks, remove it, and adjust the checkstand supports (screws). If the MP70XX still rocks, continue to remove the device and adjust the supports until it sits solidly in the checkstand.

When the platter is flush, its leading edge should be slightly below the checkstand, and the trailing edge should be slightly above the checkstand.

To ensure smooth scanning, ensure the platter is in place, take a steel can (e.g., a soup can), turn it over so the harsher seam is facing down, and slide the can over the platter in the standard scanning direction. The can must not catch on the checkstand, or the platter when swept across all sections of the platter, in the correct direction.

For the long MP70XX, secure the screws in place with lock nuts.

- ii. Medium MP70XX and short (shelf mount) MP70XX: If the platter is not flush, or the MP70XX rocks, adjust the leveling screws to place the device at the correct height. This can be done from the top of the MP70XX, with the platter removed.

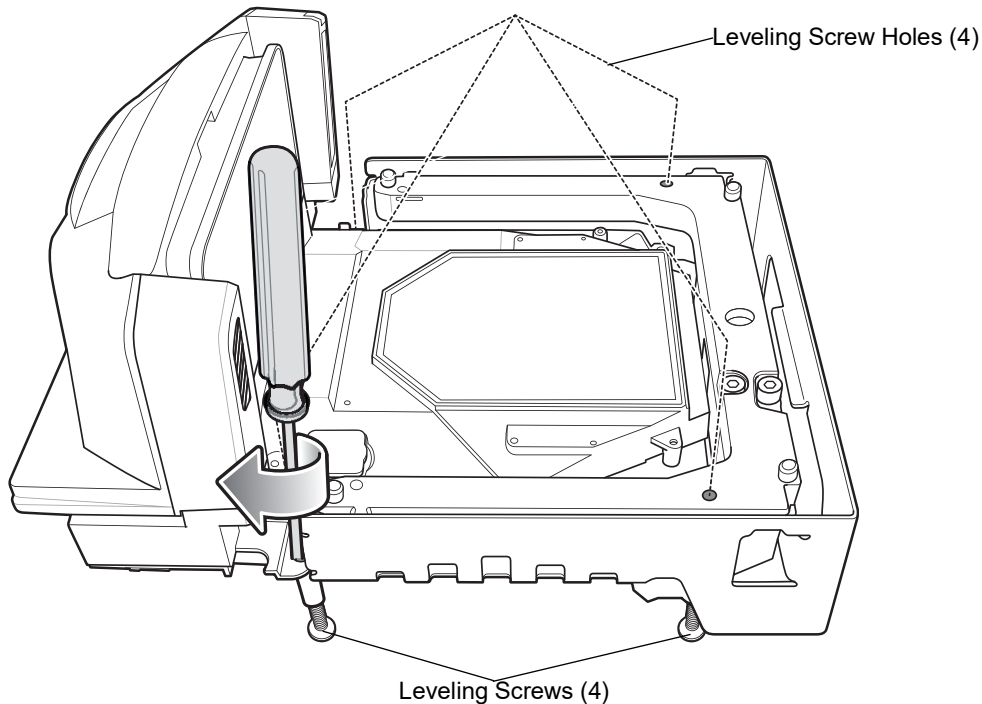

Figure 3-22 Adjusting Leveling Screws



IMPORTANT Standard length leveling screws ship with all short and medium models (kit MX301-SR00004ZZWR).

Longer length screws are available as an accessory (kit # MX302-SR00004ZZWR) contains four extra-length screws which will protrude 1" inch (25 mm) below the bottom of the unit. See [Figure 1-5 on page 1-12](#) for the installation location of these screws and for the locations of access holes for turning the screws from above.

- iii. When the platter is flush, its leading edge should be slightly below the checkstand, and the trailing edge should be slightly above the checkstand.

To ensure smooth scanning, replace the platter, take a steel can (like a soup can), turn it over so the harsher seam is facing down, and slide the can over the platter in the standard scanning direction. The can must not catch on the checkstand or the platter when swept across all sections of the platter, in the correct direction.

4. Route all cables through the checkstand as shown in [Figure 3-3](#).
5. Connect all cables to the MP70XX and POS, as needed (e.g., scale, Scale Display, Checkpoint antenna, or Sensormatic coils, POS, CSS, etc.).
6. Power up the MP70XX. Upon power up, the MP70XX verifies that all sub-systems, and auxiliary devices are operational. If a fault condition exists, an error condition displays on the 7-segment display, and the startup sequence halts. Power cycling is required after rectifying the problem. (See *General Error and Warning Codes on page A-4*)

If a scale is present, warm-up time for the scale is 30 minutes (assuming room the temperature is 70° F/20° C).



IMPORTANT Most accessories (scale, Scale Display, Checkpoint interlock, Sensormatic coils, Sensormatic RS-232 cable, CSS, and auxiliary RS-232 scanners) must be installed and connected to the MP70XX prior to applying power to the MP70XX.

Install the Sensormatic Coil Antenna



IMPORTANT Refer to the *ZBAMB5470A EAS Label Deactivator Antenna Installation Guide* that ships with the antenna installation kit for detailed instructions on connecting the antenna.

The antenna is installed behind the vertical glass and below the platter, on the middle housing. The coil connector is routed alongside the scanner to which the Sensormatic controller box lead can connect.

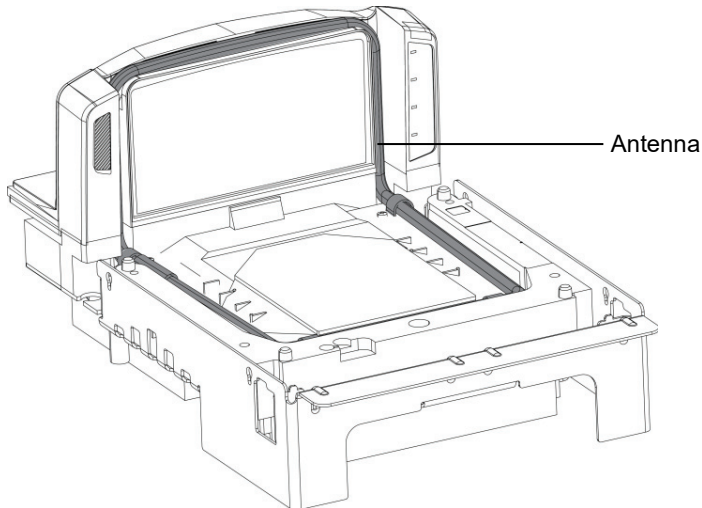

Figure 3-23 *Sensormatic Coil*

To install the Sensormatic coil in the MP70XX:

1. Remove the MP70XX platter.
2. Disconnect power to the MP70XX.
3. Place the antenna around the vertical scan window and into the body of the scanner.

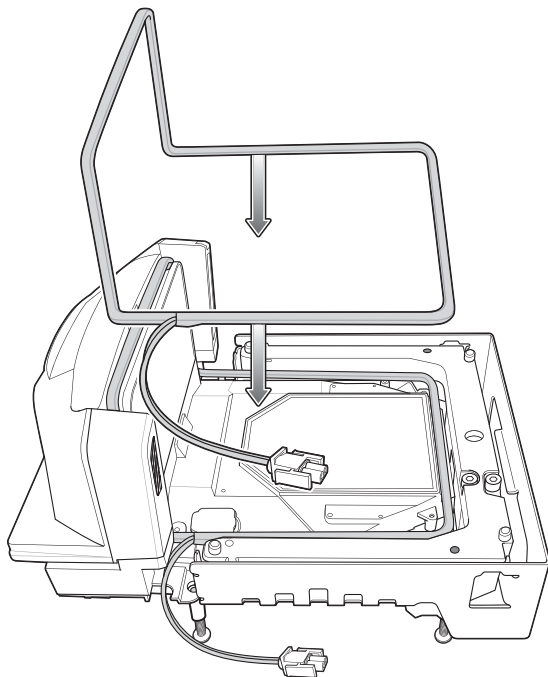

Figure 3-24 *Installing the Horizontal Coil*

4. Locate the four screws from the installation kit.
5. Align the clamps on the antenna over the four screw holes in the scanner and insert the screws.

✓ **NOTE** Ensure the antenna is centered in the scanner and away from the scale arm.

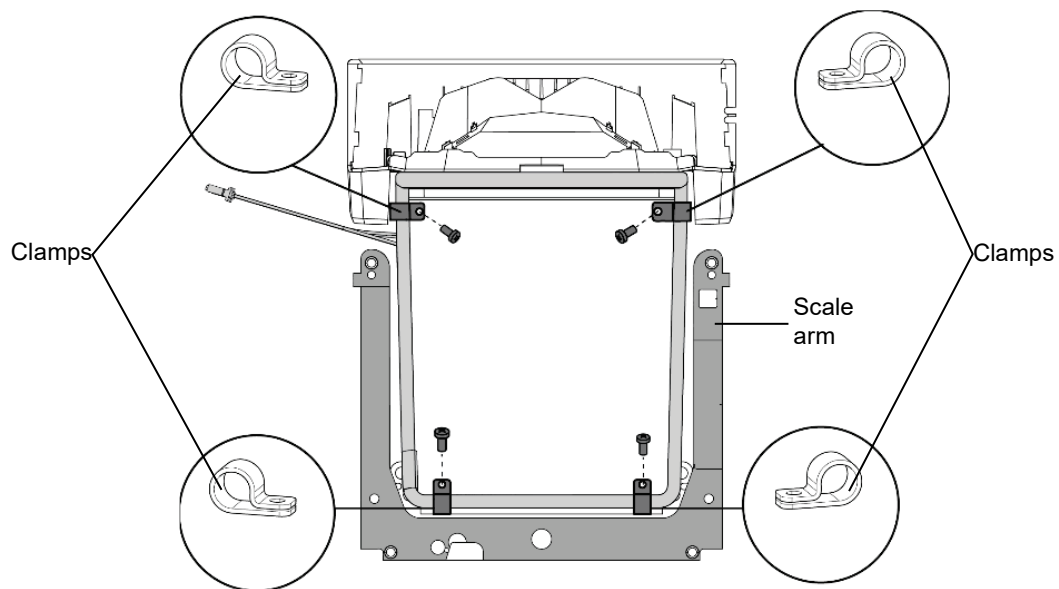

Figure 3-25 *Installing the Horizontal Coil*

6. Using a Phillips screwdriver, tighten each of the four screws to secure the antenna in place.
7. Replace the platter.
8. Follow the instructions in the *ZBAMB5470A EAS Label Deactivator Antenna Installation Guide* to complete the connection of the cable (supplied by Sensormatic) to the Sensormatic Controller.

Install the Checkpoint Antennas



WARNING! ! If the checkpoint antennas are not installed correctly they can cause issues with scale functionality.

There are two Checkpoint EAS antennas available. They can each be used separately or together for better range.

- The horizontal Checkpoint antenna should be set into place in the middle housing of the MP70XX, under the platter, and the antenna leads for controller connection should be placed as shown in [Figure 3-28](#). (See [page 1-10](#) for cable routing.)
- The vertical Checkpoint antenna loops around the top of the vertical window (see [page 3-24](#)).

Horizontal Checkpoint Antenna

The horizontal Checkpoint antenna kit, p/n MX306-SA00WW, includes the following parts.

- Horizontal Checkpoint antenna
- 3 #4-24 HI-LO .375" long screws with a T8 torx head.

To install the antenna:

1. Remove the MP70XX platter.
2. Set the antenna into place in the middle housing of the MP70XX, under the platter.

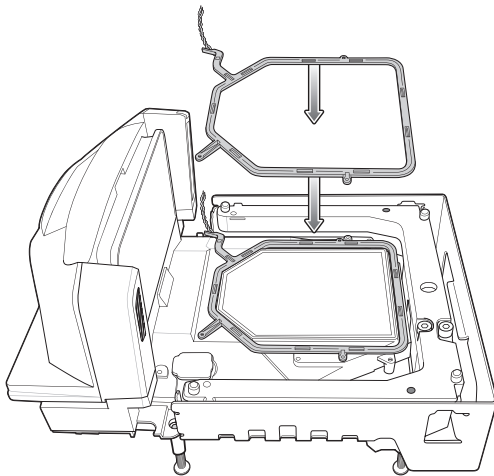

Figure 3-26 Set Antenna in Place

3. Screw the antenna to the housing using a T8 Torx screwdriver (not provided).

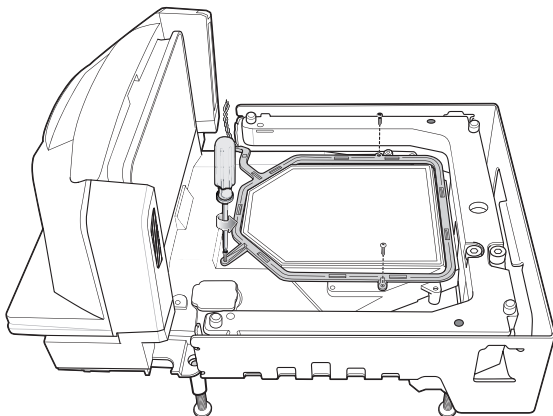

Figure 3-27 Secure Antenna to Housing

4. Route the antenna leads, with partly-stripped ends, as pictured in [Figure 3-28](#) hanging several inches below the MP70XX so that the Checkpoint controller lead wires can tie into the antenna.

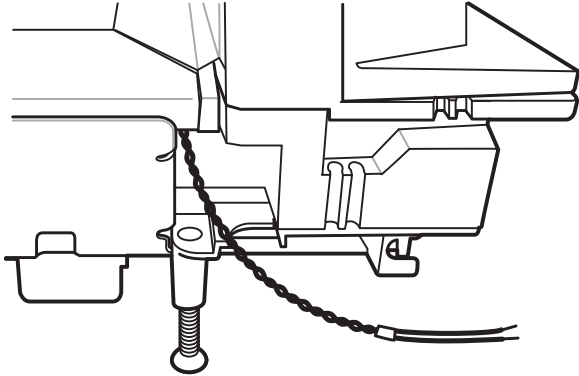

Figure 3-28 *Antenna Leads for Checkpoint Controller Connection*

5. Replace the platter.

A cable with two additional leads is available to support Interlock features. The Interlock cable assembly part number is CB000002A01, ordered as CBA-A54-S01EAR (includes a connector, and a pigtail for Checkpoint).

Contact your local Checkpoint representative to install the EAS cable to the Checkpoint System. Refer to the Checkpoint device documentation for details about its functionality.

Vertical Checkpoint Antenna

The vertical Checkpoint antenna kit, p/n MX307-SA00WW, includes the following parts.

- Checkpoint antenna
- Left bracket
- Right bracket
- Wire connector
- 2 #6-19 HI-LO 0.5" long screws with T8 torx head.

To install the antenna:

1. Remove the MP70XX platter (see [Figure 5-8 on page 5-6](#)).
2. Ensure the right side bracket is pre-attached to the wire as shown in [Figure 3-29](#).

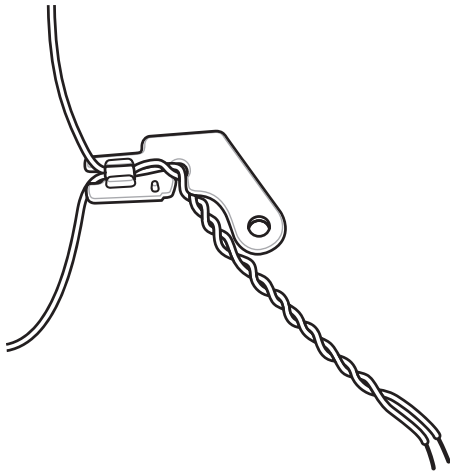

Figure 3-29 *Pre-attach Wire to Right Side Bracket*

3. Hang the antenna loop around the top right corner of the vertical window.

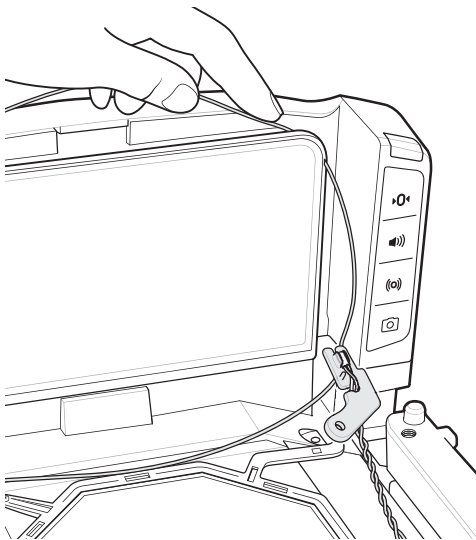

Figure 3-30 *Hang Antenna Loop*

4. Place the right side bracket, with attached wire, on the right side housing.

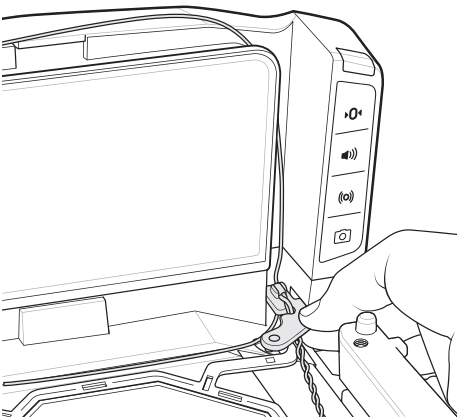

Figure 3-31 *Set Antenna to Housing*

5. Screw down the bracket keeping one lower wire below the bracket and dress it across, below the vertical window.

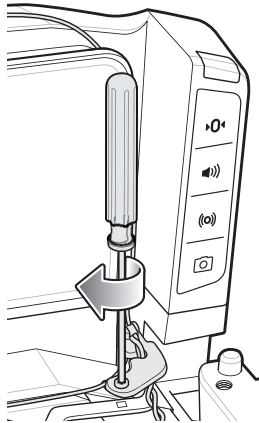

Figure 3-32 *Secure Right Side Bracket - Dress Wire Across*

6. Drape the antenna around the top of the vertical window and loop it over the top left corner.

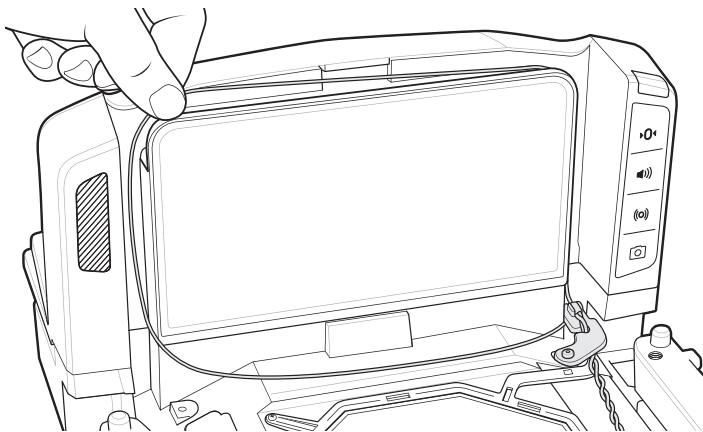

Figure 3-33 *Hang Antenna Loop Around Left Side*

7. Snap the wire into the left side bracket slot near the left screw hole.

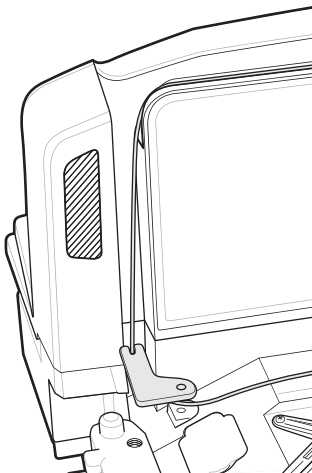

Figure 3-34 *Snap Wire to Left Side Bracket*

8. Place the left side bracket above the left screw hole, keep one lower wire below the bracket, and dress it across, below the vertical window.

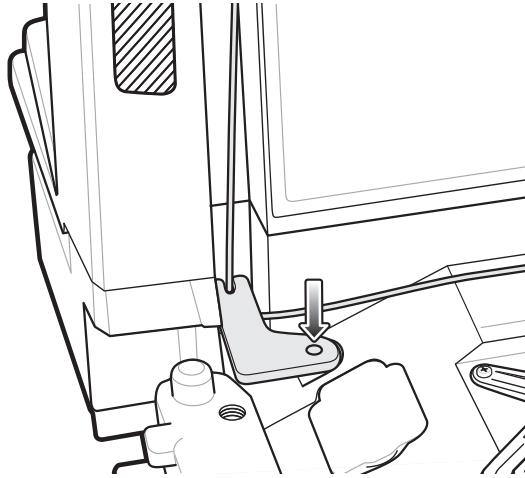

Figure 3-35 *Secure Left Side Bracket - Dress Wire Across*

9. Screw down the bracket keeping one lower wire below the bracket and dress it across, below the vertical window.

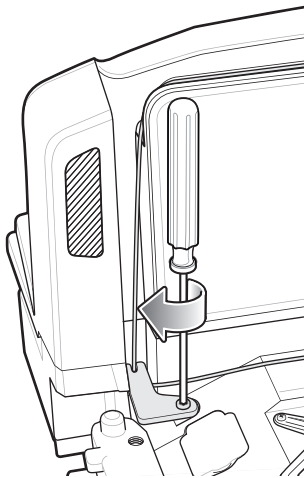

Figure 3-36 *Screw Down Left Bracket*

10. When installation is complete the wiring, left side and right side brackets, and antenna should resemble the placement in [Figure 3-37](#).

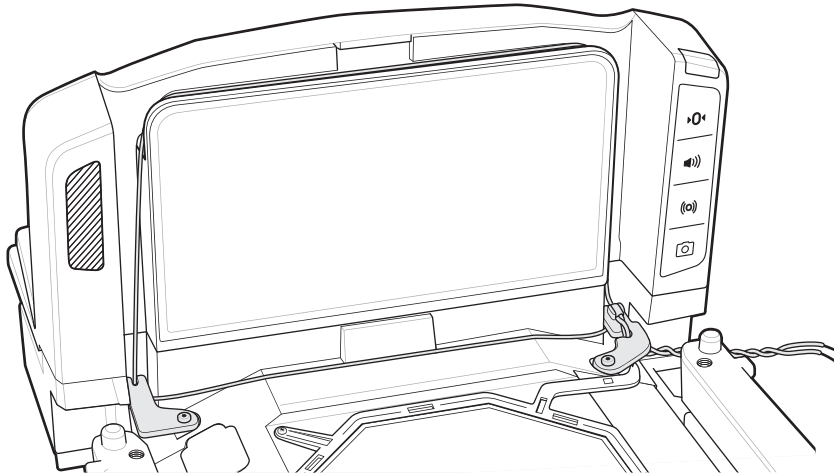

Figure 3-37 *Completed Installation*

11. Replace the platter.

12. If using both the horizontal and vertical antennas, connect the antenna wires by picking one wire each from each antenna, remove the insulation, and twist them together.

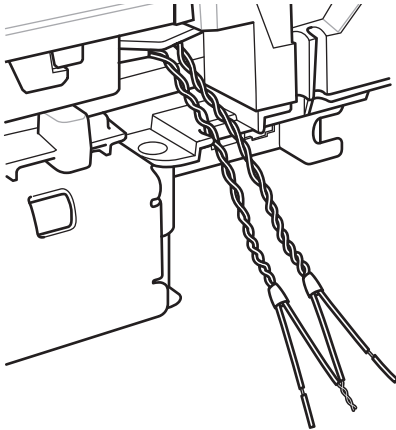

Figure 3-38 *Connecting the Horizontal and Vertical Antennas*

13. Install the wire connector provided in the MX307 kit.

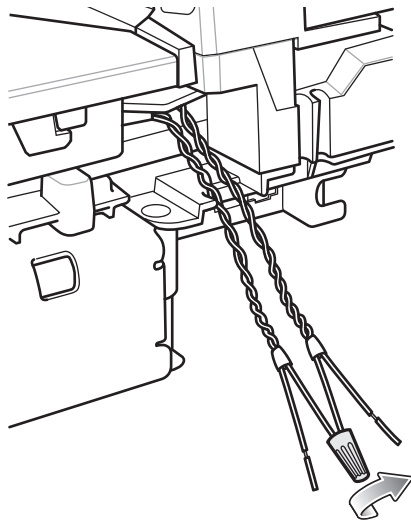

Figure 3-39 *Installing the Wire Connector*

14. Contact your local Checkpoint representative to install the EAS cable to the Checkpoint System. Refer to the Checkpoint device documentation for details about its functionality.

Trim Kit Installation (If Required)

The MX303-SB-05 trim kit can be used to modify the long MP70XX/scale to fit into a counter cut-out previously occupied by a 12 in. wide NCR scanner/scale. The trim can be mounted on either side of the MP70XX. It should be installed in the downstream side of the conveying goods. The trim adds 0.5 in. (1.2 cm) to the width of the MP70XX.

The kit includes one metal trim, and two Phillips head screws (M4 x 8mm).

To install the trim:

1. Insert the two screws provided in the rail.
2. Orient the adapter as shown in the illustration.

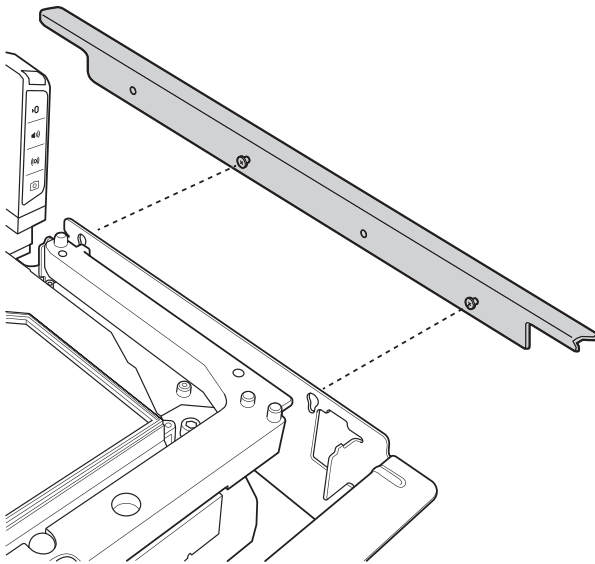

Figure 3-40 *Orient the Adapter*

3. Attach the side rail to the MP70XX, and tighten using a Phillips head screwdriver.

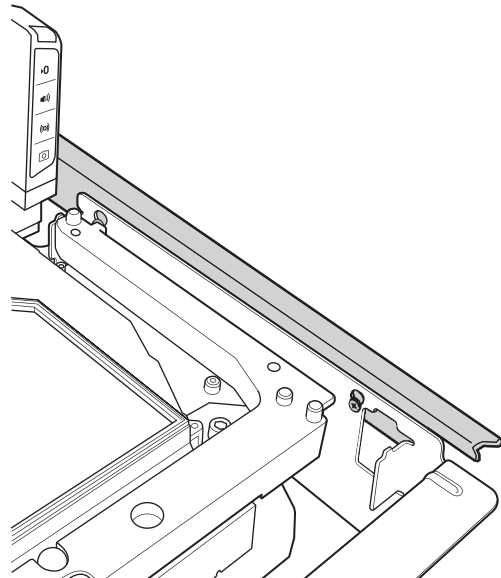

Figure 3-41 *Attach the Adapter*

CHAPTER 4 SCALE CALIBRATION (FOR MODELS WITH A SCALE)

Introduction

This chapter describes how to calibrate the scale in the MP70XX, and how to program its features.

The parameter barcodes included in this chapter are listed in [Table 4-1](#).

✓ **NOTE** All scanner programming barcodes and additional scale parameter barcodes are located in the *MP7000 Scanner Scale Barcode Programming Guide* (p/n MN-002912-xx).

Table 4-1 Scale Parameters in this Chapter

Parameter	Parameter Number	Parameter Name	Page Number
Legal Scale Units	995	Kilograms (default)	4-13
		Pounds	4-14
Scale Display Configuration	986	Disable Scale Display (default)	4-16
		Enable Scale Display	4-15
Legal Scale Dampening Filter	996	Higher Vibration Sensitivity	4-17
		Low Vibration Sensitivity (default)	4-18
		Very Low Vibration Sensitivity	4-19
		Ultra Low Vibration Sensitivity	4-20
Scale Pole Display Type	1692	Standard Pole Display Type (default)	4-21
		Alternate Pole Display Type	4-22

Scale Calibration Procedure (Scanner/Scale Configurations Only)

Follow the steps below to calibrate the scale.



NOTES

1. The 30 second timer, resets after each successful stage of the calibration procedure (not applicable at the [Step 6 - Calibration Success or Failure](#) stage).
2. If a Scale Display is unavailable, the internal 7-segment one character display can be used as a user interface to prompt a user through the steps of the scale calibration procedure.
3. The scale can be calibrated without a Scale Display. However, if a Scale Display is used **Enable Scale Display Configuration** (page [4-15](#)) must be scanned to enable the display and its port. The default Scale Display configuration is: Disabled.
4. The MP70XX scanner/scale must remain powered for a minimum of 30 minutes after a cold power start prior to performing the calibration procedure.
5. At any time during the calibration process: if the units of measure are modified (e.g., lb to kg), and a 30 second timeout is completed, the Scale Display flashes *CAL* and the 7-segment display has a U14 warning code (indicating *Scale Out of Calibration*).

Scale Configurations

Table 4-2 *Scale Configurations*

Description
Single interval 0.01 lb (0.005 kg), without calibration switch (model # ending in -01).
Single interval 0.01 lb (0.005 kg), with calibration switch (model # ending in -02).
Dual interval 0.005 lb (0.002 kg) minimum verification interval, without calibration switch (model # ending in -03).
Dual interval 0.005 lb (0.002 kg) minimum verification interval, with calibration switch (model # ending in -04).



IMPORTANT Only one calibration entry method can be used for scale configuration, (electronic entry, or manual entry).

The MP70XX platter can be removed to see the model number of the scale. The model number is printed on a label affixed to the right side of the bottom bar of the scale's U frame. The last two digits in the model number define the scale's configuration (see [Table 4-2](#)).

Step 1 - Electronic Entry into Calibration Mode

Encompasses all scales sold **without** a mechanical calibration switch installed. When the integrated scale does not have a calibration switch, electronic entry is required.

To perform an electronic calibration entry:

- Press and hold the **Scale Zero** and **Volume** buttons continuously for five seconds. After five seconds a short beep sounds. Release the **Scale Zero** and **Volume** buttons.
- Within two seconds after releasing the buttons, press the **Scale Zero** and **Volume** buttons again and release. After release the system sounds five long beeps and enters scale calibration.

When Calibration Mode is entered successfully, the scanner emits five long beep sounds. The optional Scale Display blinks *CAL00* and *CAL__* and the 7-segment display scrolls *C00Lb*, or *C00g*. Once the scale Calibration Mode is successfully entered, continue the Calibration process with [Step 3 - Program Legal Parameters on page 4-4](#).



IMPORTANT If Calibration Mode was not entered successfully, the scale remains in its current state.

Step 2 - Manual Entry into Calibration Mode

Only for scales sold with a mechanical calibration switch installed.

Some Weights and Measure regulatory jurisdictions require a mechanical calibration switch. When the integrated scale has a calibration switch installed, perform the steps that follow to manually enter Calibration Mode to calibrate the scale.

To calibrate the scale manually:

1. Remove the platter (see *Removing the Short or Medium Platter on page 5-6*).
2. If applicable, remove the security seal (wired, or tamper evident film seal) over the Calibration switch cover screw.
3. Remove the Calibration switch cover screw with an Allen wrench.
4. Press and release the Calibration switch two times.

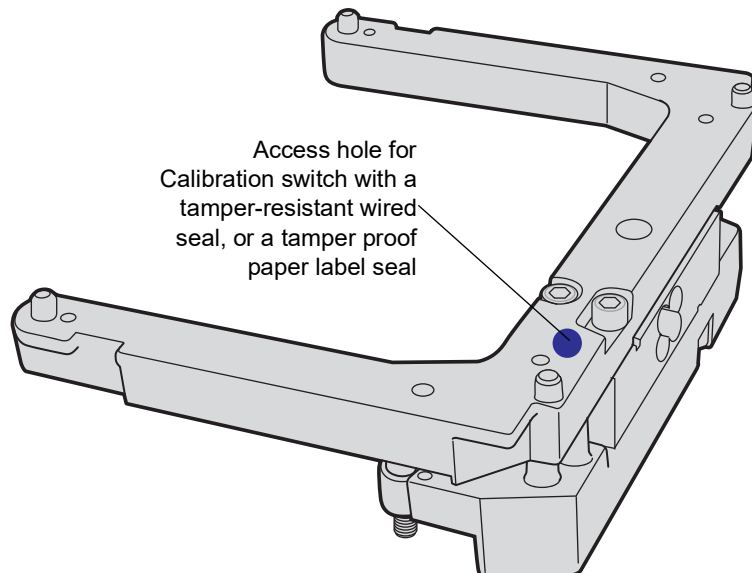

Figure 4-1 Scale/Calibration Switch

5. Reinstall the platter and ensure there is no weighted load on the platter.

✓ **NOTE** If the platter is not installed properly the Scale Display blinks the letters PLA, and persistent beeps sound until the platter is installed correctly.

6. When the platter is properly installed, and Calibration Mode is entered successfully, the scanner emits five long audible beeps. The Scale Display blinks CAL00 and CAL __ and the 7-segment display scrolls C00Lb, or C00g. (See [Step 4 - Calibration at NO LOAD on page 4-5](#)).
7. With a successful entry into Calibration Mode, continue the Calibration process with [Step 3 - Program Legal Parameters on page 4-4](#).



IMPORTANT. If Calibration Mode was not entered successfully, the scale remains in its current state, or the Scale Display blinks CAL F. The scale returns to its prior state only if there are no failures during calibration. If the Scale Display blinks CAL F, the issue must be fixed before re-entering calibration to enable an operational scale.

Step 3 - Program Legal Parameters

Sealable and legal parameters (*Unit Selection* and *Dampening Filter Setting*) can only be programmed/changed when the MP70XX is placed into Calibration Mode. There is no requirement to change these values (they can remain in the default or present state). However, if there is a need to change their values they must be programmed when the scale is in a Calibration Mode. The *Dampening Filter Setting* can be changed multiple times during a Calibration Mode without affecting the calibration outcome.

After completing these changes, the calibration process re-starts with [Step 4 - Calibration at NO LOAD on page 4-5](#). If you change the *Unit Selection* value before successfully reaching [Step 6 - Calibration Success or Failure on page 4-7](#) and the Calibration Mode exits, the scale will be non-operational. The scale will have to be successfully calibrated before it becomes operational.

Legal Scale Units (Unit Selection) - Kilograms or Pounds

To change the legal parameter *Unit Selection* (when the scale is in a Calibration Mode):

1. Verify the units of weight measurement by checking the *Scale Display* icon (the icon displays either *lb* or *kg* units), or the 7-segment display which scrolls either Lb or g units (g indicates kg units).
2. If the weight unit needs to be changed (e.g., from *kg* units to *lb* units or vice-versa), scan the appropriate *Legal Scale Units* barcode (see [Legal Scale Units on page 4-13](#)). If you do not change the default, or current weight unit, the scale calibrates with the default (*kg*) or previously programmed unit.

✓ **NOTE** The unit selection legal parameter can be scanned at any time after entering a Calibration Mode. After a successful scan, Calibration Mode restarts at [Step 4 - Calibration at NO LOAD on page 4-5](#).

Additional scale parameter barcodes are located in the *MP7000 Scanner Scale Barcode Programming Guide* (p/n MN-002912-xx).

Important Notes

1. Automatic zero setting is enabled for metric scales (kg), and disabled for US scales (lb).
2. Automatic zero setting, if enabled, is performed if weight has remained below zero, and stable (i.e., no motion on the platter) for at least 5 seconds. The scale is automatically set to zero when the 5 seconds expires.
3. If the weight units change from lb to kg, this setting is enabled after a cold power start of the MP70XX. A scale reset (e.g., via the Scale Reset **STISCLRST** barcode) WILL NOT enable this setting. Likewise, if weight units change from kg to lb, this setting is disabled. This setting is illegal for US (lb) scales.

Legal Scale Dampening Filter

Set the scale sensitivity to vibration by scanning the appropriate barcode (see page [4-18](#)). To program this parameter, the scale must be in Calibration Mode. Barcode command values are as follows:

- 0 = Higher (most sensitive to vibration)
- 1 = Low (factory default)
- 2 = Very Low
- 3 = Ultra Low

The lower the number, the more sensitive the scale is to vibration. The higher the number, the slower the scale may operate.

Step 4 - Calibration at NO LOAD



IMPORTANT This step of the calibration procedure must be completed within 30 seconds. If this time expires before completing the step then the calibration procedure is exited.

When Calibration Mode enters properly, the Scale Display blinks between *CAL00* and *CAL__* and the 7-segment display scrolls *C00Lb*, or *C00g*. Scale calibration can begin.

1. Ensure the platter is installed and there is **NO WEIGHTED LOAD** on it.
2. Touch the **Scale Zero** button on the front panel.
3. If *Calibration at NO WEIGHTED LOAD* is successful after the **Scale Zero** button is pressed, the process continues with [Step 5 - Calibration at LOAD on page 4-5](#).
or
If *Calibration at NO WEIGHTED LOAD* is not successful after the **Scale Zero** button is pressed, the process continues with [Calibration Failure on page 4-8](#).

Step 5 - Calibration at LOAD



IMPORTANT This step of the calibration procedure must be completed within 30 seconds. If this time expires before completing the step then the calibration procedure is exited.

- The Scale Display blinks either *CAL25* or *CAL11*, depending on the units of measure programmed (*CAL25* = pounds; *CAL11* = kilograms).
- The diagnostic 7 -segment display scrolls *C25Lb* or *C11g*.

To continue with calibration:

1. Depending on the units of measure programmed, place 25 lb or 11 kg on the scale. Ideally these weights should be grouped in the center of the scale (*Figure 4-2*).

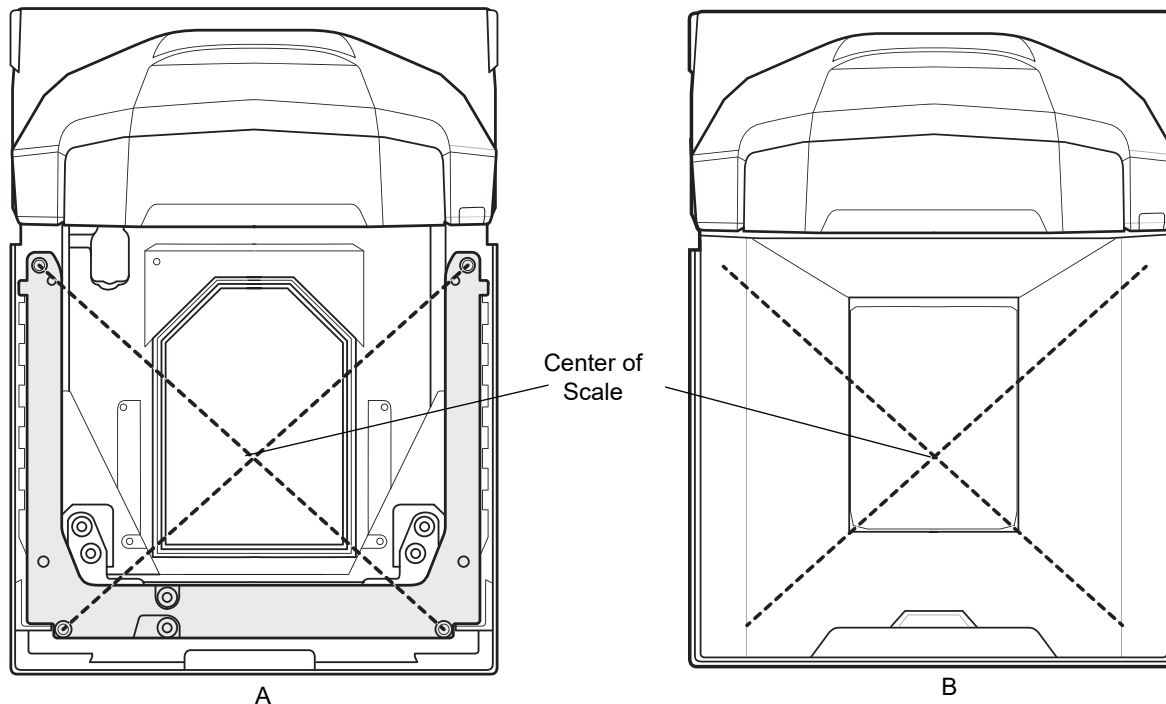

Figure 4-2 (A) Center of Scale Location, and (B) Center of Scale Location with Platter Installed

- a. Place 25 lb weights on the scanner as shown in *Figure 4-3*; three 5 lb weights centered on the center of the scale, and two 5 lb weights centered on top.

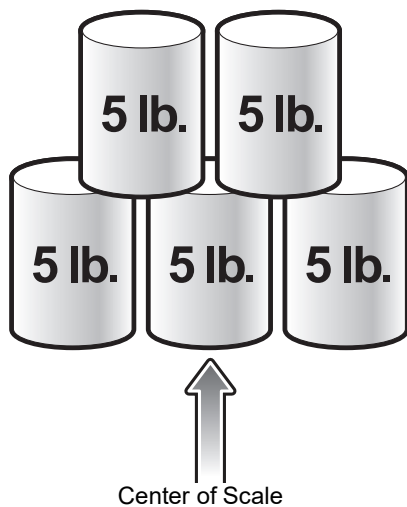

Figure 4-3 Weight Calibration Configuration for Pounds

- b. Place 11 kg weights on the scanner as shown in [Figure 4-4](#); two 5 kg weights centered on the center of the scale, and one 1 kg weight on top between the two 5 kg weights.

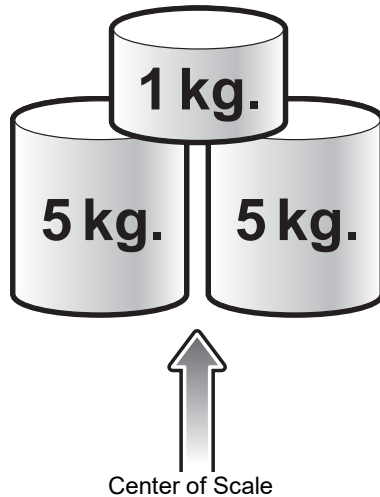

Figure 4-4 Weight Calibration Configuration for Kilograms

2. Press the **Scale Zero** button with the weights on the platter.
3. Calibration continues with [Step 6 - Calibration Success or Failure on page 4-7](#). Calibration was either successful or failed at this step.

Step 6 - Calibration Success or Failure

Calibration Success

The calibration process is successful if the Scale Display blinks between *CAL P* and *CAL S*, and the 7-segment display scrolls between *CAL P* and *CAL S*.

✓ **NOTE** P = pass; S = Save and Reset the Scale.

There are two ways to finalize the calibration process:

1. After the Scale Display starts blinking between *CAL P* and *CAL S*, remove the weights from the scale.
2. Touch the **Scale Zero** button for the scale to reset. The MP70XX scanner/scale emits three short beeps to indicate that the calibration was successful and all parameters are saved.

or

Scan the **Scale Reset** barcode (or issue an equivalent RSM command to the MP70XX scanner/scale). All programming barcodes are available in the *MP7000 Scanner Scale Barcode Programmers Guide*, p/n MN-002912-xx.

✓ **NOTE** **Scale Reset** can be scanned at anytime in the procedure to exit the calibration process with no impact (as long as a *Legal Parameter* was not changed during calibration).

3. The scale is ready to measure weight.



IMPORTANT If the manual calibration entry method was used, and a successful calibration and verification was performed, a new security seal must be installed. Reinsert the calibration cover screw aligning the hole in the screw with the hole in the scale U-bar; then insert, or use approved sealing method.

Examples of sealing methods are wire seal/crimp, approved plastic seal, or a tamper evident paper seal (where approved) may be used over the screw.

Calibration Failure

It is possible to encounter a failure condition in which the calibration process is interrupted. In this case, use the error message indicators to fix the problem and re-start the calibration process.

If calibration failed, the Scale Display blinks *CAL F*, and the error code *u##* scrolls on the 7-segment display (see [Table A-2 on page A-6](#) for error descriptions).

Possible Reasons for a Fail

- The scale returns to its prior state if [Step 4 - Calibration at NO LOAD](#) executes and the Scale Display blinks *HOLD* for the entire 30 second time period, and then times out. This condition does not display a calibration failure because the process was unable to find a zero weight threshold. This may occur if the platter was not re-installed or seated correctly, or if the weight on the scale is outside a +/- 2% maximum capacity range (+/- 0.6 lb or +/- 0.3 kg). It can also be a mechanical issue if the scale was not installed correctly.
- The scale returns to its prior state if [Step 5 - Calibration at LOAD](#) executes but the scale was unable to detect a load of 25 lb (or 11 kg, depending on the units of measure programmed). This may occur if the correct weights were not placed on the platter before pressing the **Scale Zero** button. It can also be a mechanical issue if the scale was not installed correctly.

In either case the scale can not accept the calibration, and returns to its prior state. There is no impact on the sealed calibration counter or the scale legal parameter counter. However, if calibration fails, the scale is non-operational until the problem is fixed and the scale is successfully calibrated. In this case, re-enter the Calibration Mode [Step 1 - Electronic Entry into Calibration Mode on page 4-3](#). The scale does not have to be reset and can be left on before re-entering Calibration Mode.

Calibration Mode Exit Conditions

Calibration Mode exits under the following conditions:

- No response is received from an external operator for 30 seconds. This timeout does not apply at [Step 6 - Calibration Success or Failure](#).
- The operator turns the MP70XX off.
- [Step 5 - Calibration at LOAD](#) completes successfully, or unsuccessfully (fails).
- A user scans **Scale Reset** (refer to the *MP7000 Scanner Scale Barcode Programming Guide, p/n MN-002912-xx*). When **Scale Reset** is scanned, a test runs, showing a series of characters on the optional Scale Display. When the test completes, the scale returns to its prior state before entering a scale Calibration Mode. See [Table 4-6 on page 4-23 \(Cold reset of scale\)](#) for the character sequence displayed.

Verification Test

[Table 4-3](#) describes the five tests needed to verify whether or not the scale was calibrated successfully.

Table 4-3 Tests to Verify Scale Accuracy

Test	Description
Increasing Load Test	This test verifies accurate weight measurement with increasing weights placed incrementally on the scale's platter, without returning weight to zero.
Over Capacity Test	This test verifies that the correct indication appears on the Scale Display when the maximum weight is exceeded.

Table 4-3 Tests to Verify Scale Accuracy (Continued)

Test	Description
Decreasing Load Test	This test verifies accurate weight measurement with decreasing weights removed incrementally from the scale's platter, without returning weight to zero.
Return to Zero Test	This test verifies that the scale returns to zero when all weights are removed.
Shift Test	This test verifies accurate weight measurement in all quadrants.

The verification tests outlined in [Table 4-4](#) and [Table 4-5](#) can be run in successive order. Use the appropriate table based on US (lb), or metric scales (kg), using applicable tolerance for single or dual interval scale models.

Table 4-4 Verification Tests for US (lb) Scales

Verification Test for US Scale Applied Load lb	Indication = Applied Load Within Applicable Tolerances	All Tolerances Are +/-	All Tolerances Are +/-	
		Acceptance Single Int	Acceptance Dual Int	
Increasing Load Test				
0.00	0.00	0.0 lb	0.0 lb	
0.10	0.10	.005 lb	.0025 lb	
5.00	5.00	.005 lb	.005 lb	
10.00	10.00	.01 lb	.005 lb	
20.00	20.00	.01 lb	.01 lb	
30.00	30.00	.015 lb	.015 lb	
Over Capacity Test				
Over Capacity 30.20	EEEE	N/A	N/A	
Decreasing Load Test				
30.00	30.00	.015 lb	.015 lb	
20.00	20.00	.01 lb	.01 lb	
10.00	10.00	.01 lb	.005 lb	
5.00	5.00	.005 lb	.005 lb	
0.10	0.10	.005 lb	.0025 lb	
Return to Zero Test				
0.00	0.00	0.0 lb	0.0 lb	
Shift Test (see Figure 4-5)				
10.00	Position 1	10.00	.01 lb	.005 lb

Table 4-4 Verification Tests for US (lb) Scales (Continued)

Verification Test for US Scale Applied Load lb		Indication = Applied Load Within Applicable Tolerances	All Tolerances Are +/-	All Tolerances Are +/-
			Acceptance Single Int	Acceptance Dual Int
10.00	Position 2	10.00	.01 lb	.005 lb
10.00	Position 3	10.00	.01 lb	.005 lb
10.00	Position 4	10.00	.01 lb	.005 lb

Table 4-5 Verification Tests for Metric Scale

Verification Test for Metric Scale Applied Load kg		Indication = Applied Load Within Applicable Tolerances	All Tolerances Are +/-	All Tolerances Are +/-
			Acceptance Single Int	Acceptance Dual Int
Increasing Load Test				
0.000		0.000	0.0 kg	0.0 kg
0.100		0.100	.0025 kg	.001 kg
2.500		2.500	.0025 kg	.002 kg
5.000		5.000	.005 kg	.003 kg
10.000		10.000	.005 kg	.005 kg
15.000		15.000	.0075 kg	.0075 kg
Over Capacity Test				
Over Capacity 15.100		EEEE	N/A	N/A
Decreasing Load Test				
15.000		15.000	.0075 kg	.0075 kg
10.000		10.000	.005 kg	.005 kg
5.000		5.000	.005 kg	.003 kg
2.500		2.500	.0025 kg	.002 kg
0.100		0.100	.0025 kg	.001 kg
Return to Zero Test				
0.000		0.000	0.0 kg	0.0 kg
Shift Test (see Figure 4-5)				
5.00	Position 1	5.000	.005 kg	.003 kg

Table 4-5 Verification Tests for Metric Scale (Continued)

Verification Test for Metric Scale Applied Load kg		Indication = Applied Load Within Applicable Tolerances	All Tolerances Are +/-	All Tolerances Are +/-
			Acceptance Single Int	Acceptance Dual Int
5.00	Position 2	5.000	.005 kg	.003 kg
5.00	Position 3	5.000	.005 kg	.003 kg
5.00	Position. 4	5.000	.005 kg	.003 kg

The weight checked at each position on the scale, shown in [Figure 4-5](#), represent halfway between the center of the platter and corner. Use a stack configuration of weights if needed (i.e., (2) 5.00 lb weights, or (2) 2.500 kg weights) depending on the units of measure programmed.

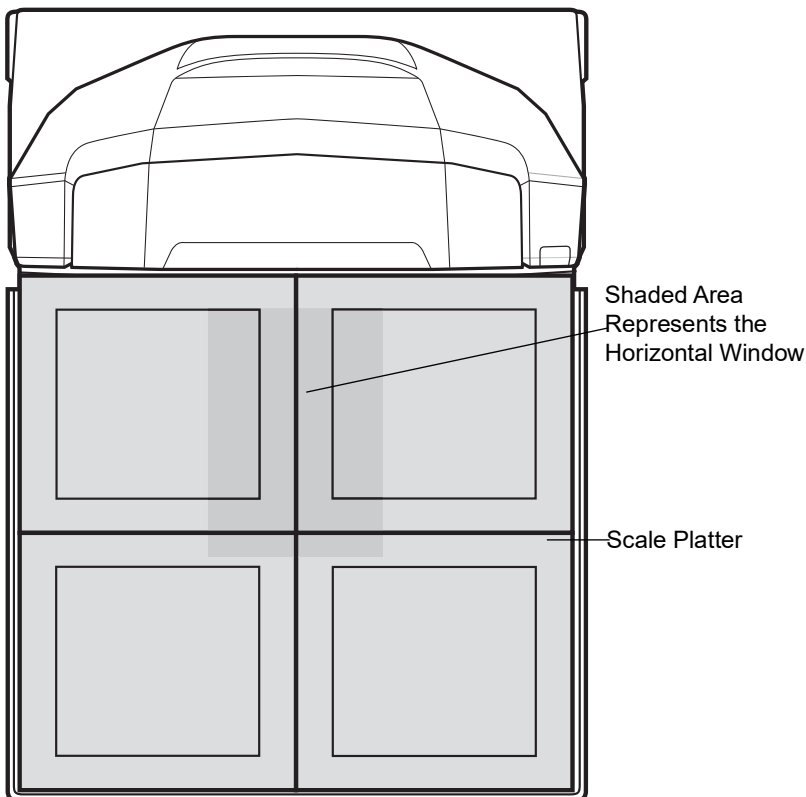

Figure 4-5 Weight Positions on the Scale Platter

While performing a shift test, the indication of each position is within the applicable tolerance and the range of results obtained should not exceed twice the applicable tolerance.



IMPORTANT After verification, record/report audit trail information to the local Weights and Measure authority where required by law.

Audit Tallies

Audit Tallies (calibration counter = C, legal parameter counter = P, Legally Relevant firmware version number = F) used for scale verification can be shown on the Scale Display, or the 7-segment display.

1. Press and hold the **Scale Zero** button for three seconds to access the calibration tallies (not within Calibration mode).
 - a. C###, P###, and #.##F tallies blink on the Scale Display and/or scroll on the 7-segment display.
 - i. C### represents the number of times the scale reached [Calibration Success on page 4-7](#). (Only successful calibrations are counted.)
 - ii. The P### represents the number of times any sealable parameter, or legal parameter was changed with or without reaching [Calibration Success on page 4-7](#). #.##F represents Legally Relevant firmware version number.
2. When the **Scale Zero** button is released, the scale returns to normal operation, and the tallies are removed from both displays.

✓ **NOTE** This feature is inhibited when the unit is in a scale Calibration Mode.

If units of weight measure was modified (i.e., kg to lb, or lb to kg) the parameter counter is incremented by two in the audit tally. This is because the **Automatic Zero Setting** legal parameter is being enabled when going from lb to kg, and disabled when going from kg to lb.

3. After verification, seal the scale by recording/reporting Audit Trail or apply physical seal to models that contain a physical calibration switch. Report information as required by local Weight & Measures Regulations, or where required by law.

Scale Configuration Parameters



NOTE Refer to the *MP7000 Scanner Scale Barcode Programming Guide* (p/n MN-002912-xx), for all programming barcodes for the MP70XX/scale.

Legal Scale Units

Parameter # 995

Scan a weight unit below to set the legal weight units for the MP70XX. Scan **Kilograms** for metric units; scan **Pounds** for the US units.



IMPORTANT The scale must be in a calibration mode to change this parameter.



* Kilograms
(0)

Legal Scale Units (continued)



**Pounds
(1)**

Scale Display Configuration

Parameter # 986

Scan **Enable Scale Display Configuration** below to enable the Scale Display port. The Scale Display port is disabled by default.



Enable Scale Display Configuration
(1)

Scale Display Configuration (continued)



*** Disable Scale Display Configuration
(0)**

Legal Scale Dampening Filter Setting

Parameter # 996

Scan a barcode below to set the vibration sensitivity of the scale. The lower the number value, the more sensitive the scale is to vibration. The scale must be in a Calibration Mode to program this parameter.

Values:

- 0 = Higher (most sensitive to vibration)
- 1 = Low (factory default)
- 2 = Very Low
- 3 = Ultra Low



**Higher Vibration Sensitivity
(0)**

Parameter # 996 (continued)



*** Low Vibration Sensitivity
(1)**

Parameter # 996 (continued)



**Very Low Vibration Sensitivity
(2)**

Parameter # 996 (continued)



**Ultra Low Vibration Sensitivity
(3)**

Scale Pole Display Type

Parameter # 1692

Scan a barcode below to set the Pole Display Type.



***Standard Pole Display Type
(0)**

Scale Pole Display Type (continued)



Alternate Pole Display Type
(1)

User Interface Displays and Signals

Table 4-6 LED and Beeper Sequences

Scale State	7-segment Diagnostic Display	LED (System)	Beeper Sequence	Scale Zero Button (LED)	Optional Scale Display
Scale disabled	No change	No change	None	OFF	Blank
Scale normal - stable with weight	No change	No change	None; single short beep after weight request from POS, if this feature is enabled.	Solid Green ON	Weight reading
Under zero	No change	No change	None	Flashing	All "-----" (dashes)
Over range condition (weight is greater than 30.09 lb, or weight is greater than 15.045 kg)	No change	No change	None	OFF	EEEE
Weight unstable	No change	No change	None	OFF	Numerical values blank but measurement unit icons (lb or kg) remain on.
Scale Zero button press	If zero operation fails it scrolls U12	Red (Warning) if zero operation fails on a Scale Zero button press; otherwise, no change	Click sound	No change	If successful weight reads 0 (zero) and <0> indicator icon illuminates.
Scale out of calibration	Scrolls fault code U14	Red (Warning)	None	OFF	Blinks CAL

Table 4-6 LED and Beeper Sequences (Continued)

Scale State	7-segment Diagnostic Display	LED (System)	Beeper Sequence	Scale Zero Button (LED)	Optional Scale Display
Successfully entering scale legal Calibration Mode	<p><i>Step 3 - Program Legal Parameters</i> and <i>Step 4 - Calibration at NO LOAD</i> - Scrolls C00Lb OR C00g depending on units programmed as pounds (lb) or kilograms (kg)</p> <p><i>Step 5 - Calibration at LOAD</i> - Scrolls C25Lb or C11g depending on units programmed as pounds (lb) or kilograms (kg)</p> <p><i>Step 6 - Calibration Success or Failure</i> - Repeat scrolls of CALP then CALS</p> <p>Any step - Calibration Fails - Scrolls fault code: u##</p>	No change	Five long beep tones	Off	<p><i>Step 4 - Calibration at NO LOAD</i> Blinks between CAL00 and then CAL__ with correct unit icon illuminated (lb or kg).</p> <p><i>Step 5 - Calibration at LOAD</i> Blinks CAL25 with lb icon illuminated, or blinks CAL11 with kg icon illuminated.</p> <p><i>Step 6 - Calibration Success or Failure</i> Blinks between CAL P (PASS) and CAL S (save legal parameter settings).</p> <p>Any step - Calibration fails blinks CAL F.</p>
Between calibration steps	No change	No change	No change	Off	Blinks <i>HOLD</i> while taking a measurement.
Stepping through a calibration step	No change	No change	Single long beep tone after pressing the Scale Zero button	Off	No change
Failure to place the correct load on the scale at <i>Step 5 - Calibration at LOAD</i>	C25Lb or C11g depending on units programmed	No change	Two long beep tones	No change	No change
Successfully executing and exiting a scale legal calibration	Calibration procedure semantics removed from display.	No change	Three short beeps	Solid green on if weight stable after reset of scale	Scale is reset either by pressing the Scale Zero button, scanning the Scale Reset parameter barcode, or powering the unit OFF then ON. The seven segment test will run.

Table 4-6 LED and Beeper Sequences (Continued)

Scale State	7-segment Diagnostic Display	LED (System)	Beeper Sequence	Scale Zero Button (LED)	Optional Scale Display
Cold reset of scale	No change	No change	No change except at Step 6 - Calibration Success or Failure - when the Scale Zero button is pressed three short beeps tones sound	No change	Seven segment test runs and displays: <ul style="list-style-type: none"> • 00.000 all icons illuminated for three seconds • Blank for one second • 99.999 all icons illuminated for three seconds • Blank for one second • Normal display
Audit Tally - Press and hold Scale Zero button for greater than three seconds when not in a Calibration Mode.	Repeated scroll: C#### then P####	No change	None	No change	Blinks between C### and P####.
In Bootloader Mode	No change	Off	None	Off	None.
Scale Error	Scrolls fault code: u##	Red (Warning)	None	Off	Blinks <i>FAIL</i> or blanks display with unit icon showing lb or kg illuminated. Display can also blink <i>CALF</i> if the system was in a scale legal Calibration Mode.

CHAPTER 5 OPERATING THE SCANNER

Introduction

This chapter describes how to operate the MP70XX, including information about indicators (LED, beeper, etc.), beeper/speaker, user buttons, weighing items, and the 7-segment character (diagnostic) display.

Controls and Indicators

See [Table 5-1 on page 5-18](#) for all beeper and LED indications.

LED

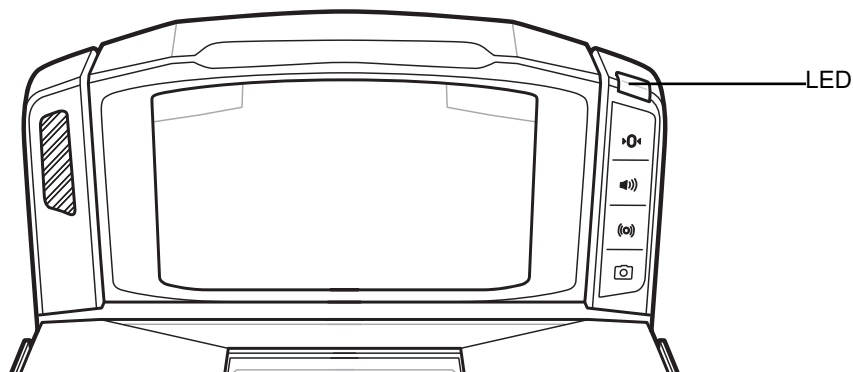

Figure 5-1 LED Location

The LED is located on the right side of the device ([Figure 5-1](#)) and provides visual feedback for system statuses and alerts. The LED provides either green or red feedback depending on the condition.

The LED illuminates in the following situations:

- Green: The unit is operating normally.
- Blinking Red/Green: Indicates a warning. The unit continues to operate with possible performance degradation.
- Red (solid): Indicates a fault. The unit does not operate correctly unless the error is resolved.

See [Table 5-1 on page 5-18](#) for LED indicator descriptions.

Diagnostic LED/7-segment Display

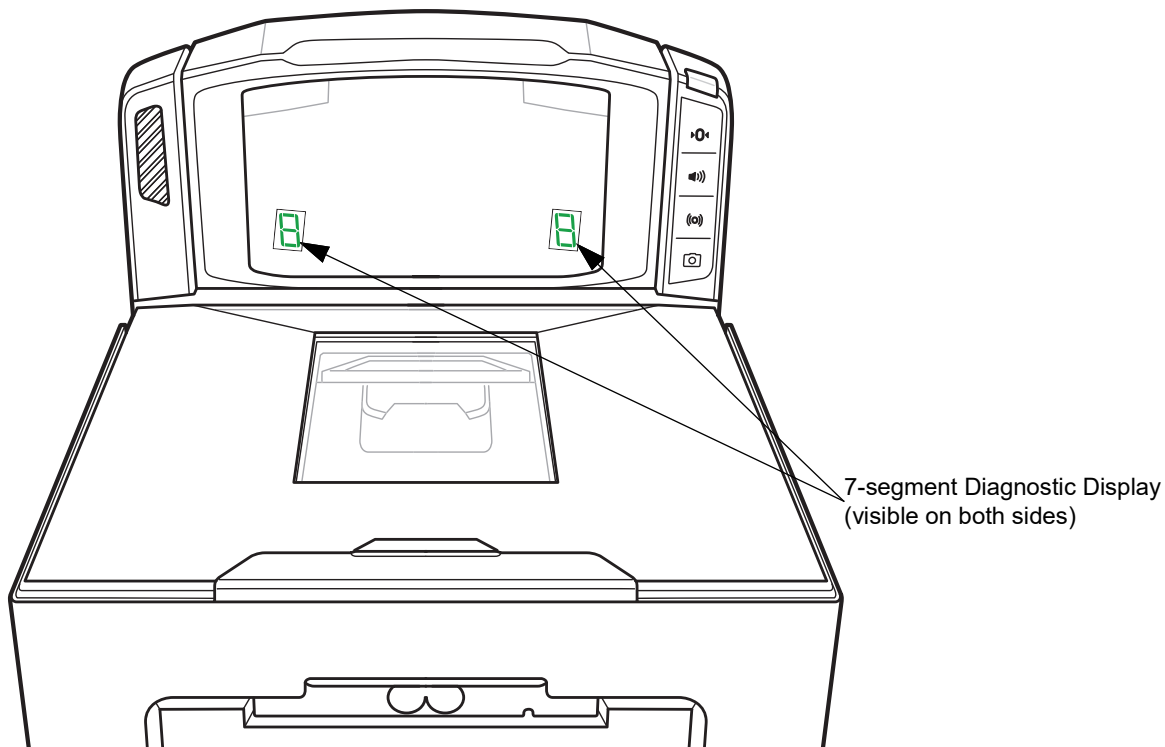

Figure 5-2 7-segment Diagnostic Display

Figure 5-2 shows the internal 7-segment display which provides error and warning codes, scale legal parameters and lead through help during scale calibration. It is visible inside the scanner's vertical window.

The 7-segment display is a one character display. Letter(s) and number(s) messages scroll one character at a time through the display. When a message is completed, the display pauses for two seconds. The message repeats continuously.

- ✓ **NOTE** When there are no issues, a dash displays to show the 7-segment display is operational.
- If the message is an error, or warning it repeats until the issue is resolved.
 - If the message is related to scale calibration it repeats until calibration is completed.
 - If the message is related to the CAL/PAR display it repeats until the inspector/tester releases the **Scale Zero** button.

See [Appendix A, Maintenance, Troubleshooting, and Error Codes](#) for status and troubleshooting messages.

Front Panel Buttons

There are four front panel buttons for ease of use.

Scale Zero Button (Configurations with Scale Only)



Figure 5-3 Scale Zero Button

This button is a scale zero button and status LED that controls some scale operation and displays scale status.

Touch **Scale Zero** to set the scale to zero (within +/- 0.6 lb, or +/- 0.300 kg). The LED is green and can be on, flashing, or off. LED brightness cannot be controlled. The allowable *zeroing weight limit* of 0.6 lb and 0.3 kg is configurable. Refer to the Maximum Scale Zeroing Weight Limit parameter in the *MP7000 Scanner Scale Barcode Programming Guide* (p/n MN-002912-xx) for more information.

See [Beeper and LED Indicators on page 5-18](#) for detailed indications.

Volume/Tone Control Button



Figure 5-4 Volume/Tone Button

This button allows user selectable settings for audible system indications. The user can control the audible feedback in the following situations:

- Decoding.
- Completion of a request (e.g., the successful decode of a barcode, and Sensormatic beep).
- Error conditions.
- Processing a request that takes an extended amount of time (e.g., scanning a sequence of parameter barcodes). This audible indication informs the user that the scanner is working, and not malfunctioning.

✓ **NOTE** If the decode tone is set to off, the **Volume/Tone** button on the MP70XX is not operational. To enable the **Volume/Tone** button, set a tone option other than Off tone. Refer to the beeper and tone settings in the *MP7000 Scanner Scale Barcode Programming Guide* (p/n MN-002912-xx).

To adjust volume and tone:

- Press and release the **Volume/Tone** button to sound the current scanner beep volume level.
- Press and release the **Volume/Tone** button twice within two seconds to change the scanner decode volume.
- Press and hold **Volume/Tone** for three seconds to change to another tone. Tones cycle.

Each volume or tone change produces an audible beep when the new setting is complete. Volume and tone wrap from high to low.

See [Beeper and LED Indicators on page 5-18](#) for detailed indications.

Sensormatic Manual Activation and Sensormatic Status Button



Figure 5-5 EAS Button

This button indicates the state of the Sensormatic EAS device. The LED is yellow/amber and can be on, flashing, or off. See [Beeper and LED Indicators on page 5-18](#) for detailed indications.

Camera Activation Button



Figure 5-6 Camera Activation Button

This button activates the built-in camera that can be used to take a picture or scan a bank check. These features are only available when **Camera Button** is enabled (parameter # 1716) and the interface is USB SNAPI ([Symbol Native API \(SNAPI\) with Imaging Interface on page 2-10](#)). When both of these conditions are met the **Camera Activation** LED illuminates.

Refer to the *MP7000 Scanner Scale Barcode Programming Guide (p/n MN-002912-xx)*, to access programmable parameters.

To Capture an Image

Press and release the **Camera Activation** button. After releasing the button the user has 2 seconds to place the item in position on the horizontal glass closest to the vertical window. During the 2 second time frame the device sounds a periodic click. After 2 seconds a camera shutter sounds to capture the image.

Both time duration and camera location are programmable features.

- **Camera Button Delay Time** (parameter # 1717) offers delays in increments of 100 ms.
- **Image Capture Camera Selection** (parameter # 1715) offers a camera location in the tower (default) or platter.

To Scan a Bank Check

Press-hold-release the **Camera Activation** button longer than 0.5 seconds. After releasing the button the user has up to 10 seconds to slide their check across the platter. One beep sounds upon successful scan. A four beep sequence sounds if the scan was unsuccessful.

Soft Reset Buttons



Figure 5-7 Soft Reset Buttons (Scale 0 and EAS buttons)

A soft reset of the MP70XX can be initiated by pressing the **Scale Zero** and **EAS** buttons simultaneously for more than 8 seconds. A two second beep sounds, then a system reset is performed.

Identifying Firmware Version

To determine the firmware version on the scanner, depress and continue to hold the **EAS** button.

After five seconds, the scanner firmware version numbers cycle one digit at a time on the internal 7-segment display.

MP7000 Scanner Scale Related Hardware

Scale Display (Scanner/Scale Configurations Only)

MP70XX models with a scale have an option for a single or dual Scale Display. The single display can be positioned to provide continuous display of weight values, and digital zero balance indication for customer and operator. The dual display offers more flexibility by allowing the two display heads to rotate independently.

Both single and dual displays show gross weight in pounds and/or kilograms (depending on location) in the following format:

Scale (Scanner/Scale Configurations Only)

Scales are available for Medium and Long versions only. Two optional scales are available.

Single Interval Range Scales

A single interval range scale has the same resolution for the entire weight range (from zero to maximum capacity). Single interval weight capacity:

0.00 - 30.00 lb at a resolution of 0.01 lb

0.000 - 15.000 kg at a resolution of 0.005 kg

Dual Interval Range Scales

A dual range scale changes resolution after a certain weight is reached. For example, 2g until 6kg, 5g above 6kg. Dual Interval weight capacity:

0.000 - 12.00 lb at a resolution of 0.005 lb; then 12.00 - 30.00 lb at a resolution of 0.01lb

0.000 - 6.000 kg at a resolution of 0.002 kg; then 6.000 - 15.000 kg at a resolution of 0.005 kg

Calibration Switch

Some countries require a mechanical calibration switch. When the integrated scale has a Calibration switch installed, perform the steps detailed in [Step 2 - Manual Entry into Calibration Mode on page 4-3](#) to manually enter a Calibration Mode to calibrate the scale.

CSS - Optional

The CSS is a modular unit which is either embedded in the MP70XX tower, or added at any time to fit on the left or right side of the MP70XX. The CSS snaps on to the MP70XX and requires no tools to install or remove. Connection to the MP70XX is via the internal USB cable.

The CSS enables shoppers to scan paper, plastic loyalty cards, or from a mobile device while a cashier scans other items simultaneously.

Platter

The platter covers the horizontal scan window, and scale (if applicable). It also accommodates product placement. The sapphire platter glass is built for long term reliability and clarity, and is impervious to scratches except from industrial diamonds.

Removing the Short or Medium Platter

To remove the short or medium platter grasp the top and edge of the platter and lift up.

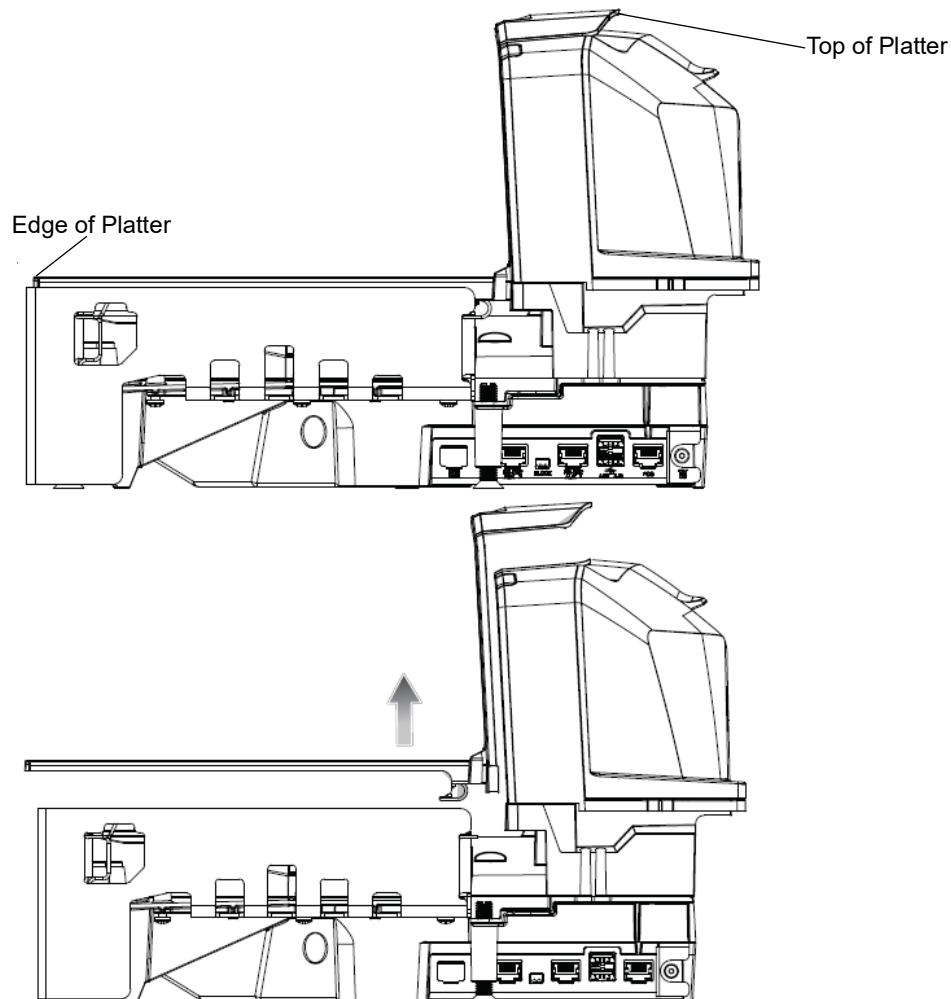

Figure 5-8 *Removing the Short or Medium Platter*

Installing the Short or Medium Platter

To install the short or medium platter grasp the top and edge of the platter and lower into place until secure.

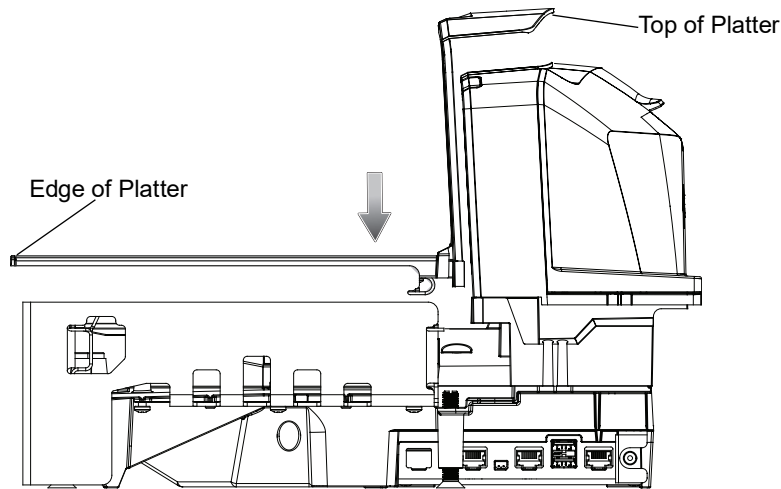

Figure 5-9 *Installing the Short or Medium Platter*

Removing the Long Platter

To remove the long platter:

1. Grasp the edge of the platter and lift up slightly.
2. Holding the edge and top of the platter, pull out and lift off.

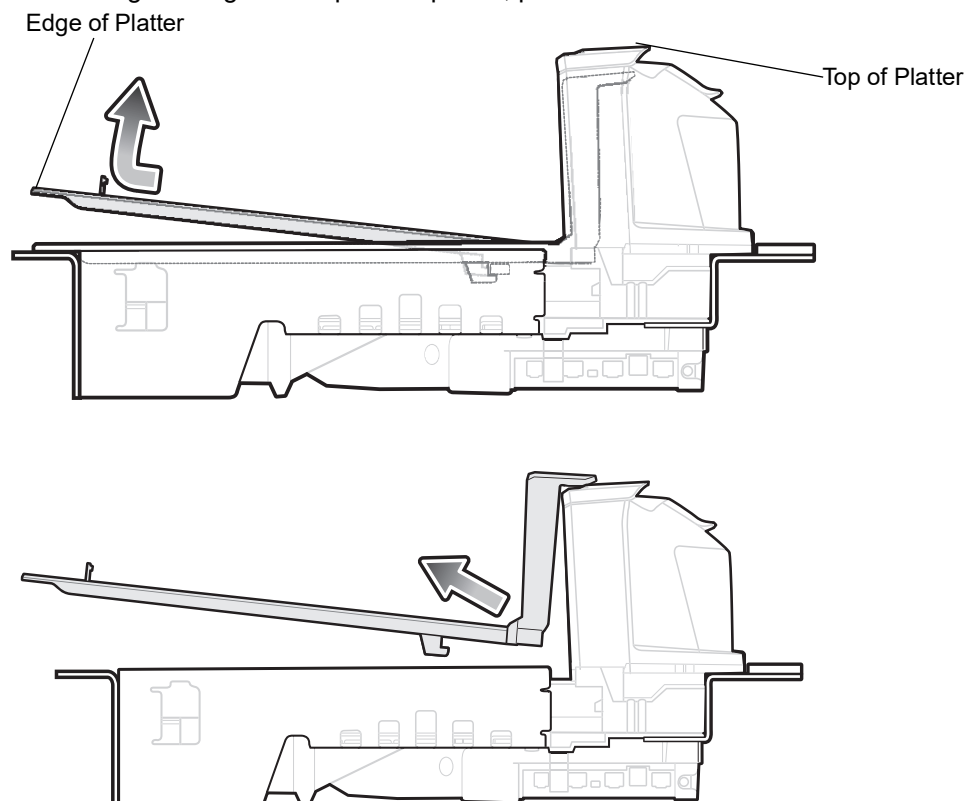

Figure 5-10 *Removing the Long Platter*

Installing the Long Platter

To install the long platter:

1. Grasp the edge and top of the platter and slide the bottom of the vertical scan window into the housing.
2. Lower the edge of platter to sit securely in the device.

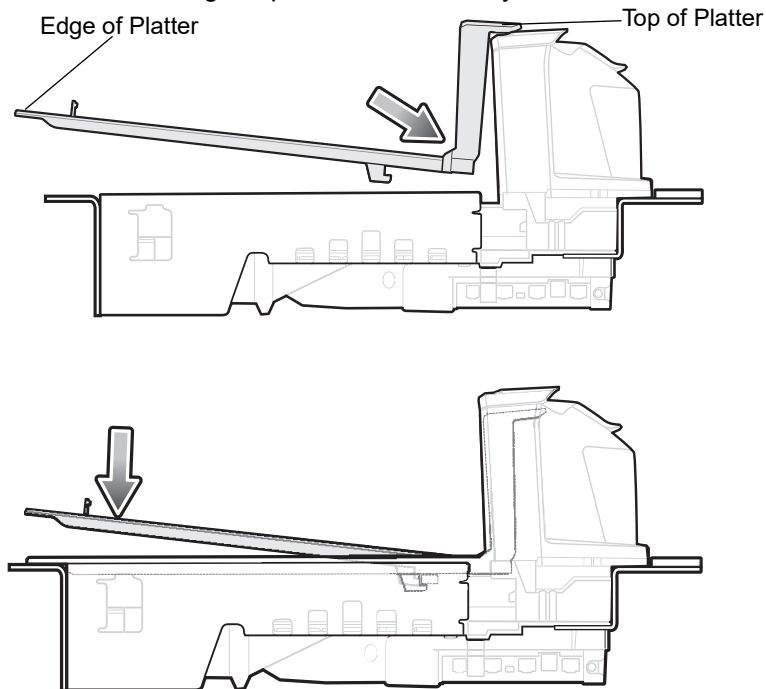

Figure 5-11 *Installing the Long Platter*

Scan Windows

The MP70XX reads 1D, 2D (PDF, Aztec etc.) and mobile barcodes (cell phone) in all orientations, and scans difficult symbols (e.g., truncated, poor contrast, and damaged barcodes). See [Scanning on page 5-14](#) for more information.

The horizontal window on the platter is clear, scratch-proof sapphire built for long term reliability and clarity, and is impervious to scratches.

The vertical window is chemically tempered, and can sustain normal product impact. In case of abusive impact outside of normal usage, this window is laminated with anti splinter film to ensure the any glass shard remains intact to the window assembly.

Operating Modes

The MP70XX has two operating modes with corresponding power requirements:

- Idle Mode 3.0 W (typical)
- Active Mode 5.5 (typical), 6.0 W (maximum)

Programming the MP70XX

The MP70XX can be programming using the following methods.

Programming Management Tools

- 123Scan (see [Chapter 7, 123Scan and Software Tools](#))
- ✓ **NOTE** If an MP70XX scans a programming 2D barcode generated by 123Scan it only programs the MP70XX. If a CSS and/or auxiliary scanner (e.g., the DS8178) are used with the MP70XX, they must be programmed separately to be configured.
- SMS
An SMS Package is a file, which when used with the SMS agent can manage a scanner remotely by programming parameters and updating firmware. An SMS Package is similar to a zip file, and includes three components:
 - 123Scan configuration file containing parameters
 - 123Scan plug-in containing scanner firmware
 - Load *Directive* file with programming details like trigger information.
- Staging flash drive reprogramming ([USB Staging Flash Drive on page 5-10](#)).

Application Programming Interfaces

- Zebra Scanner SDK APIs (CoreScanner APIs)
- ✓ **NOTE** SDK supported functionality by communication protocol is listed in [Appendix E, Communication Protocol Functionality](#).
- Zebra Scanner OPOS/JPOS APIs
- WMI Interfaces.

For access to the APIs go to: zebra.com/scannersdkforwindows.

Programming Barcodes

With the exception of host interface, and initial scale setup parameters refer to the *MP7000 Scanner Scale Barcode Programming Guide* (p/n MN-002912-xx) includes all the parameter barcodes necessary to configure the device.

USB Staging Flash Drive

A staging USB flash drive can be used to:

- a. Set up an MP70XX system from a 123Scan generated set of files
- b. Perform MP70XX system cloning and/or
- c. Collect MP70XX statistics, usage, and diagnostics data.

A staging flash drive can be created by 123Scan and/or from an MP70XX.

- A 123Scan generated staging flash drive can perform device setups from 123Scan to multiple MP70XXs.
- An MP70XX generated staging flash drive can perform the following functions:
 - a. Device cloning from one MP70XX to multiple MP70XXs.
 - b. Back up system settings from an MP70XX (the MP70XX parameter settings can be imported into 123Scan).
 - c. Collect statistics, usage, and diagnostics data (the data can be viewed in 123Scan).

MP70XX Menu Structure for the USB Staging Flash Drive

- **Option 1** - Copy an MP70XX¹ configuration to the USB flash drive.
 - Copy parameter settings and firmware from the MP70XX¹ to the USB flash drive for cloning to another device, or viewing in 123Scan.
 - When **Option 1** is available the 7-segment display shows a **1**, and one beep sounds.
- **Option 2** - Load a USB flash drive configuration to the MP70XX¹.
 - Load the parameter settings and firmware (if present) from the staging USB flash drive to this MP70XX¹.
- ✓ **NOTE** The MP70XX system configuration settings and firmware are overwritten.
 - When **Option 2** is available the 7-segment display shows a **2**, and two beeps sound.
- **Option 3** - Copy statistics, usage, and diagnostics data to the USB flash drive.
 - Copy data from the MP70XX onto the USB flash drive (the data can be viewed in 123Scan).
 - When **Option 3** is available the 7-segment display shows a **3**, and three beeps sound.
- Exit without doing anything - Remove USB flash drive from the MP70XX.

¹ Auxiliary device settings, like Zebra corded scanners, are copied/loaded if applicable. Auxiliary cordless scanners are not supported.

See [Loading Cloning Files on page 5-12](#) for the process steps.

Manually Staging/Configuring MP70XX Devices

Manually staging/configuring MP70XX devices using a USB flash drive is a three step process.

Step 1: Generate the staging files, and load to a USB flash drive.

Step 2: Deploy the USB flash drive to transport staging files to an MP70XX.

Step 3: Load the files and configure the MP70XX by inserting the staging flash drive.

The MP70XX has three USB ports which can be used to load files (see [Figure 5-12](#)):

- Two external ports on the side of the device.
- One internal port accessible by removing platter. The internal port sits straight up, and includes a cap cover which must be replaced when the drive is not in use. A missing, or incorrect placement of the cap does not allow the platter to sit properly when replaced.



IMPORTANT See [Approved USB Flash Drives for the Flash Drive Well on page 5-13](#) for the recommended flash drive dimensions for use in the internal USB port.

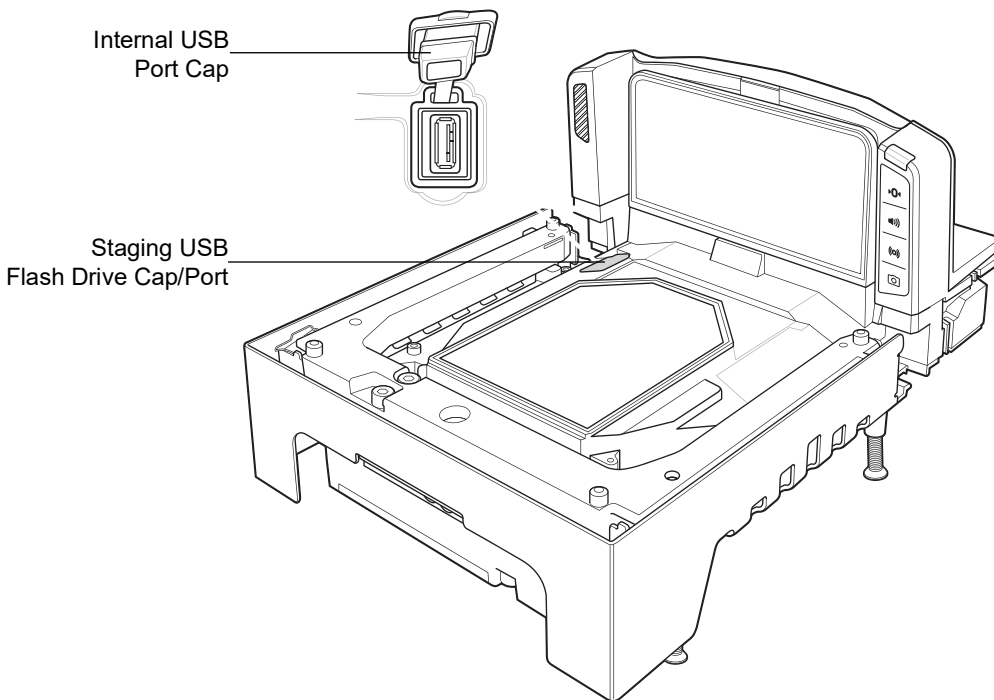

Figure 5-12 *Internal USB Port Under Platter*

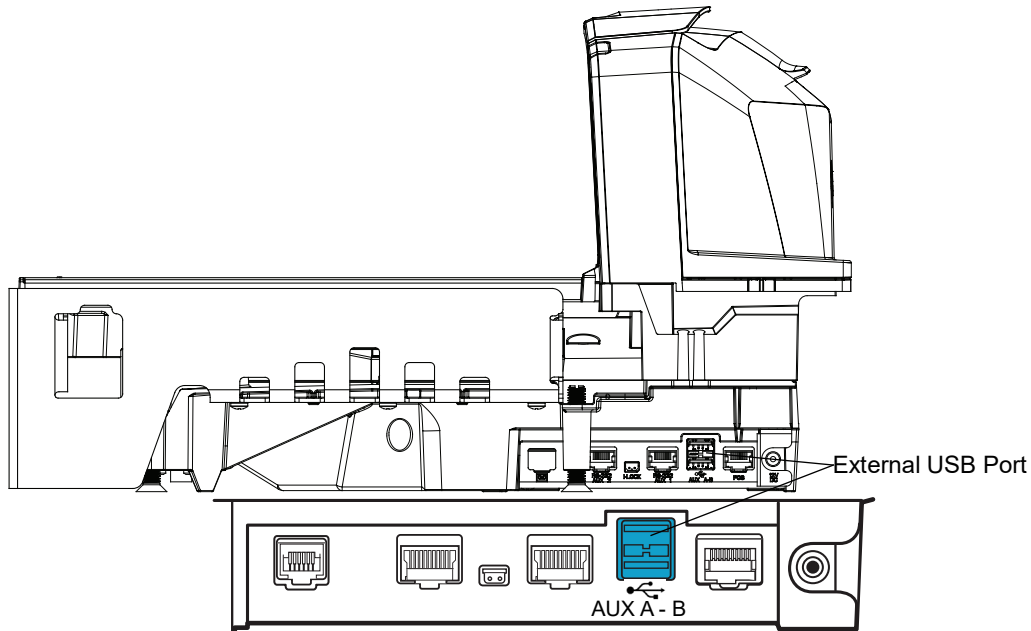

Figure 5-13 External USB Port

Loading Cloning Files

Cloning files can be loaded to the staging flash drive two ways:

- Insert the staging flash drive into one of the MP70XX USB ports ([Figure 5-12](#)), and select *Option 1 - Load Files* (see [Step 3](#)).
- Use 123Scan to create and export files to the staging flash drive. (See [123Scan Staging Flash Drive Configuration](#) for more information.)

- ✓ **NOTE** The USB flash drive must be at least 2.5 in. (63.5 mm) long to be accessible for removal after insertion into the internal MP70XX flash drive well. Alternatively, some USB flash drives include an opening in their rear covers into which a paper clip can be looped to help achieve the minimal length dimension.

See [Approved USB Flash Drives for the Flash Drive Well on page 5-13](#) for the recommended flash drive dimensions for use in the internal USB port.

It is recommended to start with a clean flash drive.

Follow the steps below to clone data.

1. Insert the staging flash drive in the USB port under the MP70XX platter.

- ✓ **NOTES** 1. If EAS was installed and operational, the **EAS** button remains lit. If EAS was not installed, and/or not operational, the **EAS** button on the front panel of the MP70XX lights when the staging flash drive is inserted.

2. While the staging flash drive is inserted:

- a) Do not remove power.
- b) Do not remove, or connect any cables.
- c) Do not press the **Volume** or **Scale** buttons.
These actions may interfere with the staging flash drive process.

2. When the staging flash drive inserts correctly, the MP70XX detects the drive, and sounds two beeps (low/high).

3. The MP70XX identifies the data on the USB flash drive, and the 7-segment display shows a flash drive menu sequence. The flash drive menu displays three number options for approximately five seconds each. See [MP70XX Menu Structure for the USB Staging Flash Drive on page 5-10](#) for menu options.
4. When the option you desire displays in the menu, you have *five seconds* to select the option by pressing the **EAS** button (see [EAS Deactivation Button \(Sensormatic only\) on page 1-9](#)). One, two, or three beeps sound, depending on the option selected.
5. You have 15 seconds to confirm the selection by pressing the **EAS** button again. (If the selection is not confirmed, four fail beeps sound, and the 7-segment display re-scrolls the menu.)
6. After confirmation, the 7-segment display shows a scrolling bar (-). This means the device is working. When the process is complete (time varies) three success beeps (high/low/high), or four failure beeps sound, and the scrolling bar stops. Removing the staging flash drive at this point sounds the success or failure beeps again from the last operation performed.

✓ **NOTE** The scrolling bar stops whether or not the cloning process succeeded or failed. If the process failed, try again or contact the System Administrator.

If the staging flash drive is removed prior to completion, a fail occurs (four beeps sound). Premature removal of the staging flash drive may result in a partial change in the system.

123Scan Staging Flash Drive Configuration

The *Flash Drive Wizard* option within the 123Scan utility steps a user through the process of generating a USB staging flash drive with cloning files.

To access the *Flash Drive Wizard* from any 123Scan screen, click *Tools > Staging Flash Drive (MP70XX only) > Create Staging Flash Drive Files*.

Approved USB Flash Drives for the Flash Drive Well

When using the MP70XX flash drive well, located under the MP70XX platter, the USB flash drive must meet the specifications below to be accessible (easily inserted into, and removed from the well):

- Maximum thickness: .43 in. (11 mm)
- Maximum width: .82 in. (21 mm)
- Minimum length 2.5 in. (63.5 mm).

Scanning

The MP70XX uses its horizontal and vertical scan windows simultaneously to read 1D, 2D (PDF, Aztec etc.) and mobile barcodes (cell phone) in all orientations.

The MP70XX includes an automatic Infra-Red (IR) wakeup system that reduces power consumption. When any object is presented in the field of view of the scan windows, the red illumination turns on, but automatically turns off when the object is removed. When the object presented in the field of view includes a barcode, the MP70XX scans the barcode, and, if the barcode is successfully decoded, the illumination LED immediately turn off when the object is removed.

Position the barcode anywhere within the MP70XX's field of view.

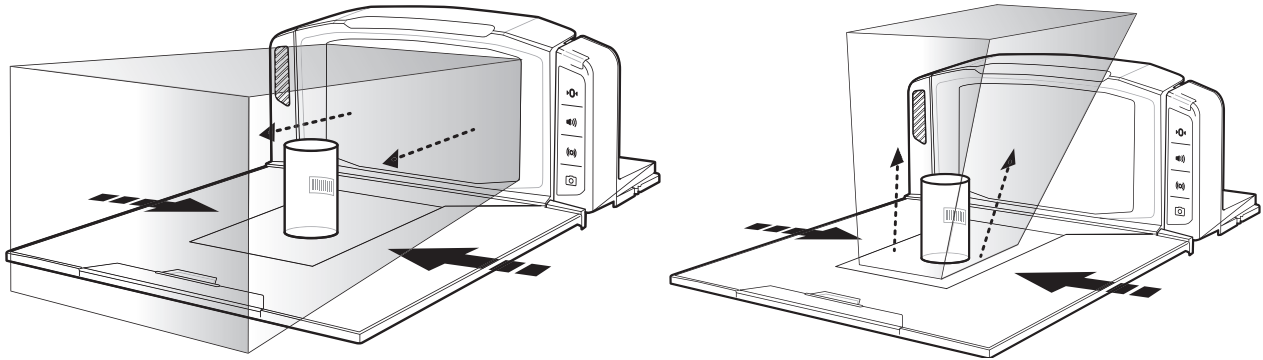

Figure 5-14 Scanning with the MP70XX

The scanner beeps to indicate a successful decode, and the green LED flashes momentarily (see [Table 5-1 on page 5-18](#)).

Weighing Items

For proper weighing, items should be placed fully on the shaded (gray) regions of the scanner.

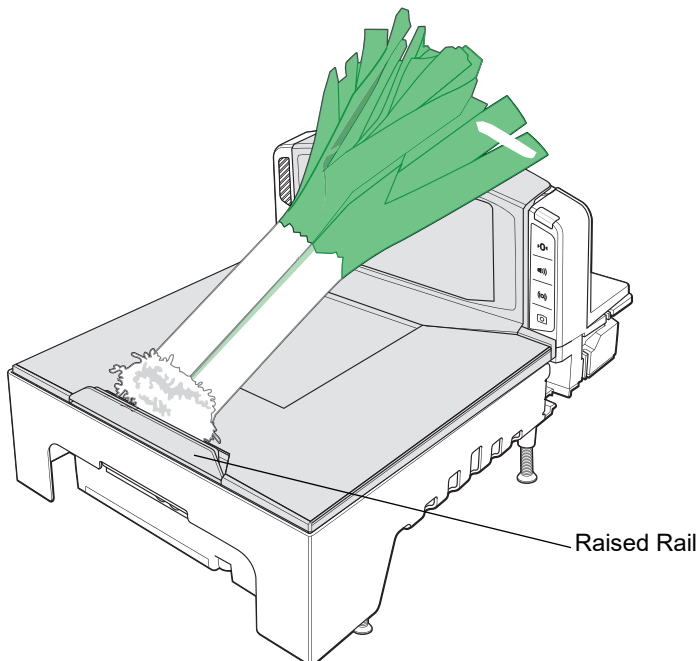

Figure 5-15 Gray Weighing Region

Long items may be weighed by laying them on the raised vegetable rail so that the end that overhangs the weighing surface is suspended above the countertop.

To weigh items, follow the steps below.

1. Ensure all items are removed from the platter, and the platter is in place.
2. Verify the Scale Display shows 0.00 lb (0.000 kg).

✓ **NOTE** If the Scale Display does not show 0.00 lb (0.000 kg), clear all items off the platter and zero the scale by touching the **Scale Zero** button.

After weighing an item, if tones are enabled, a sound emits indicating transmission of a stable, non-zero weight.

3. If weighing does not occur, press **CLEAR** on the POS and try entering the weighed item's PLU number again. If an error code displays, or an error beep sounds, remove the item from the platter, remove the platter and check for debris underneath. If there is debris, remove it. Replace the platter, and press the **Scale Zero** button to reset the scale. Wait for 0.00 lb (0.000 kg) to display on the Scale Display and weigh the item again.

✓ **NOTE** If an error code displays in the 7-segment display, check [Table A-1 on page A-4](#) for likely causes and troubleshooting. If those suggestions do not help, take note of the error message and call your service provider or help desk. See [7-segment Diagnostic Display \(visible on both sides\) on page 1-9](#) for the location of the 7-segment display.

Electronic Article Surveillance (EAS)

The MP70XX has integrated Electronic Article Surveillance (EAS) options which allow support for Sensormatic EAS controllers or Checkpoint EAS controllers. (See [EAS Devices on page 1-8](#) for supported EAS controllers.)

The MP70XX and EAS system can operate independently of each other, or using communication cable to synchronize deactivation with barcode scanning. The deactivation range is mapped suitable to the scanner range, so both can be accomplished almost simultaneously

Supported EAS Controllers

- Sensormatic
 - Sensormatic AMB-9010
 - Sensormatic AMB-9010-IPS
- Checkpoint
 - Checkpoint Interlocked, requires interlock cable: CB000002A01
 - Checkpoint Non-Interlocked.

✓ **NOTE** Checkpoint and Sensormatic EAS systems require proper installation by representatives from those companies who install, verify, and tune the system for proper EAS operation. This is typically done on-site by those companies.

EAS Operating Modes and Settings

EAS operating modes function when EAS is enabled at the site and are independent of whether or not EAS equipment is connected. It is the installer's responsibility to match these settings with the installed equipment. Enabling EAS without EAS equipment, or with the wrong equipment installed, displays an EAS error message. See [Beeper and LED Indicators on page 5-18](#) and [Diagnostic LED 7-segment Display - Error and Warning Codes on page A-2](#) for beeper, warning, and error messages. Also refer to the *MP7000 Scanner Scale Barcode Programming Guide* (p/n MN-002912-xx) for EAS barcodes.

The default mode for EAS is disabled. Disable EAS when this technology is not used, or if you are using Checkpoint without interlock.

There are 10 EAS operating modes and various EAS preferences for the MP70XX:

- Sensormatic Auto
- Sensormatic Always Enabled
- Sensormatic Barcode Interlock
- Sensormatic Barcode Auto Interlock
- Sensormatic Self Service
- Sensormatic Scan Enable Interlock
- Checkpoint Barcode Interlock
- Checkpoint Scan Enable Interlock
- Checkpoint Non Barcode Interlock
- EAS Disable.

For detailed information about these modes, and the parameter barcodes, refer to the *MP7000 Scanner Scale Barcode Programming Guide* (p/n MN-002912-xx).

Checkpoint Controller

Checkpoint EAS soft tags can be detected and deactivated by a deactivation antenna mounted under the platter (see [Install the Checkpoint Antennas on page 3-23](#)). EAS labels should be brought near the antenna to be deactivated.

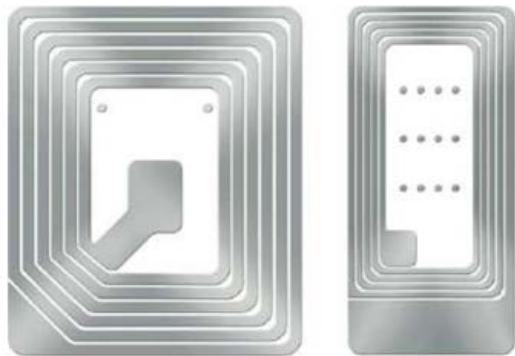

Figure 5-16 Checkpoint EAS Tags

Sensormatic Controller

The Sensormatic controller includes a custom vertical and horizontal, high inductance antenna. The horizontal antenna is installed below the platter, on the middle housing, and is affixed to the housing with screws. The vertical antenna resides behind the vertical glass, and is also affixed to the scanner with screws. (See [Install the Sensormatic Coil Antenna on page 3-21](#)).

Sensormatic EAS should always be enabled. There is no synchronization with a barcode read in this mode.

Sensormatic EAS Hard Tags



Figure 5-17 Sensormatic EAS Hard Tags

The detection of hard tags alerts the user with audible Geiger counter beeps. Environments with a mix of hard and soft tags sound a unique user alert (soft/hard tag beep).

Sensormatic EAS Soft Tags (Labels)



Figure 5-18 Sensormatic EAS Soft Tags (Labels)

Deactivation of soft tags alerts the user with audible Geiger counter beeps. Deactivation of soft tags synchronized with a barcode scan alerts the user with audible Geiger counter beeps. Soft tags can be disabled, and they can also be reset using a Sensormatic tag re-setter.

Beeper and LED Conditions

Table 5-1 *Beeper and LED Indicators*

Condition	Beeper Indication	System LED Indication	Button LED Indication	Description
ADF Programming				
Number expected	High, Low Beeps	Green	No change	Enter another digit. Add leading zeros to the front if necessary.
Alpha character expected	Low, Low Beeps	Green	No change	Enter another alphabetic character or scan the End of Message barcode.
Criteria or action expected	High, High Beeps	Green Blinking	No change	ADF criteria or action is expected. Enter another criterion or action, or scan the Save Rule barcode.
ADF rule saved	High, Low, High, Low Beeps	Green (turns off blinking)	No change	Rule saved. Rule entry mode exited.
Criteria or action cleared	High, Low, Low Beeps	Green	No change	All criteria or actions cleared for current rule, continue entering rule.
Last rule deleted	Low Beep	Green	No change	Delete last saved rule. The current rule is left intact.
All rules deleted	Low, High, High Beeps	Green	No change	All rules are deleted.
ADF out of memory	Low, High, Low, High Beeps	Red	No change	Out of rule memory. Erase some existing rules, then try to save rule again
Cancel rule entry	Low, High, Low Beeps	Green (turns off blinking)	No change	Cancel rule entry. Rule entry mode exited because of an error or the user asked to exit rule entry.
Rule error	Low, High Beeps	Red	No change	Entry error, wrong barcode scanned, or criteria/action list is too long for a rule. Re-enter criterion or action.
Button Presses				
Press and release Scale Zero button	Click	No change	Scale Zero button LED blinks green (momentary)	LED illuminates only if Scale Zero button is enabled. Causes the scale to zero.
Press and hold Scale Zero button	Click	No change	None	If Scale Zero button is enabled, causes the scale calibration audit trail to display until button is released.

Table 5-1 *Beeper and LED Indicators (Continued)*

Condition	Beeper Indication	System LED Indication	Button LED Indication	Description
Press and hold/release Scale Zero and EAS buttons	Click	Red after 10 seconds upon reboot	No change	After buttons are held for 10 seconds, a system reboot initiates.
Press and hold Scale Zero and Volume/Tone buttons for 5 seconds, then release	Short beep after 5 seconds; within 2 seconds of release, press the Scale Zero and Volume/Tone again and release; 5 long beeps sound	No change	No change	After final 5 long beeps sound, scale calibration is entered.
Press and release EAS button	Click	No change	EAS is enabled, LED is amber	If EAS is enabled, button press activates tag manual deactivation.

Camera Activation Button Presses

Press and release the Camera Activation button	Periodic clicks until shutter sounds indicating a picture was taken	No Change	No Change	Takes a picture.
Press-hold-release (hold longer than 0.5 seconds) the Camera Activation button to scan a bank check.	Periodic clicks until check scan completes. <ul style="list-style-type: none"> • Successful completion - one beep sounds. • Unsuccessful completion - four beep sequence sounds. 	No Change	No Change	Scans a bank check.

Code 39 Buffering

Code 39 character added into buffer	High, Low Beeps	No change	No change	New Code 39 data was entered into the buffer.
Code 39 buffer full	3 Long High Beeps	No change	No change	Code 39 buffer is full.

Table 5-1 *Beeper and LED Indicators (Continued)*

Condition	Beeper Indication	System LED Indication	Button LED Indication	Description
Code 39 buffer cleared	High, Low, High Beeps	No change	No change	The Code 39 buffer was erased.
Code 39 buffer empty	Low, High, Low Beeps	No change	No change	The Code 39 buffer was erased or there was an attempt to clear or transmit an empty buffer.
Code 39 buffer transmitted	Low, High Beeps	No change	No change	A successful transmission of buffered data.
EAS/Security Tags				
EAS system disabled	None	No change	EAS LED is off	EAS parameter disabled.
EAS system functional (idle)	None	No change	EAS LED is on	EAS is operating normally.
EAS tag detected anytime	Configurable: None, Geiger Counter clicks	No change	EAS LED blinks yellow at 4 Hz	An EAS tag is in the EAS tag detected area, and being detected.
EAS manual deactivation activated	None	No change	EAS LED on	When deactivation is active on the system.
EAS Soft Tag Deactivation	None, Beep 1, Beep 2	No change	No change	Beep indicates that a soft tag was deactivated.
EAS Hard Tag Detected	None, Beep 1, Beep 2	No change	No change	Beep indicates that a hard tag was detected.
Firmware Download				
Firmware Download	Low, Medium, High beep after complete	Red alternating between on and fast blink	No change	Firmware download in progress. Firmware Download has multiple states. The LEDs during these states are: <ul style="list-style-type: none"> • During firmware data download/transfer - no LED control. • After reboot firmware is installed: LED blinks red, fast. • After complete, normal power-up beep.
Parameter Programming				
Parameter entry error	Low, High Beeps	Red	No change	Input error: incorrect barcode, programming sequence, or Cancel scanned.
Parameter number entry expected	High, Low Beeps	Green	No change	Number expected. Enter value using numeric barcodes.

Table 5-1 *Beeper and LED Indicators (Continued)*

Condition	Beeper Indication	System LED Indication	Button LED Indication	Description
Parameter entry accepted	High, Low, High, Low Beeps	Green	No change	Successful program exit with change in parameter setting.
Macro PDF				
Macro PDF buffered	2 Low Beeps	No change	No change	MPDF sequence buffered
Macro PDF file ID error	2 Long Low Beeps	No change	No change	File ID error. A barcode not in the current MPDF sequence was scanned.
Macro PDF buffer out of memory	3 Long Low Beeps	No change	No change	Out of memory. There is not enough buffer space to store the current MPDF symbol.
Macro PDF bad symbology encountered	4 Long Low Beeps	No change	No change	Bad symbology. Scanned a 1D or 2D barcode in a MPDF sequence, a duplicate MPDF label, a label in an incorrect order, or trying to transmit an empty or illegal MPDF field.
Macro PDF buffer flushed	5 Long Low Beeps	No change	No change	Flushing MPDF buffer.
Macro PDF aborted	Fast Warble Beep	No change	No change	Aborting MPDF sequence.
Macro PDF buffer flushed with no data	Low, High Beeps	Red	No change	Flushing an already empty MPDF buffer.
Scale: See Table 4-6 on page 4-23 for scale conditions and displays.				
Standard Use				
System power-up	Low, Medium, High Beeps	None	No change	Power up.
System reboot	Loud two seconds beep	No change for 10 seconds. Red for last two seconds.	No change	After holding the Scale Zero and EAS buttons for 10 seconds, the MP70XX reboots.
Barcode decoded	Off, Low, Medium, High, two-tone beep, or TBD tone (programmable)	Bright green	No change	One bright green LED flash.
System is idle	None	Dim green	No change	LED constant on; ready for decode.
System is disabled	None	Off	No change	Host application has sent SCAN-DISABLE command.

Table 5-1 *Beeper and LED Indicators (Continued)*

Condition	Beeper Indication	System LED Indication	Button LED Indication	Description
Barcode data transmission error	4 Low Beeps	Red	No change	Transmission error.
Barcode data conversion error	5 Low Beeps	Red	No change	Conversion or Format error.
RS-232 host parity error	Low, Low, Low, Extra Low Beeps	Red	No change	RS-232 Receive error.
BELL (RS-232)	High Beep	None	No change	A <BEL> character is received over RS-232.
Volume				
Pressed and release Volume/Tone button	Annunciates volume level	No change	Button LED blinks for two seconds (at 2 Hz)	Volume change: causes the current volume level to be announced. If pressed within two seconds of the previous (or while volume LED is blinking), it annunciates the volume at the next level. Once the maximum volume level is reached, it wraps and begins at the lowest volume level.
Press and hold Volume/Tone button for two seconds	Annunciates decode tone	No change	Button LED blinks for two seconds	Decode tone changes Subsequence decode tones are heard every second if continuously held. Decode tones cycle.
Decode tone change (Describes action above)	Button click; decode beep at next tone (wrap)	No change	No change	After holding the Volume button for two seconds, the next decode tone sounds. For each additional second the decode tone changes again.

CHAPTER 6 COLOR CAMERA INSTALLATION AND USE

Introduction

The MP7000 Scanner Scale color camera kit, purchased separately, adds a color camera to the MP7000 that allows the capture and transfer of images and video over a USB connection.

Color Camera Kit

Table 6-1 *Color Camera Kit Contents*

Kit Part Number	Description
MXC7000-P	MP7000 Portrait Color Camera Kit Kit Contents: <ul style="list-style-type: none">• Camera With Portrait Adapter• Rear Tower Cover• Illumination Boards (2)• Cabling Harness• USB Cable• Service Label
MXC7000-L	MP7000 Landscape Color Camera Kit Kit Contents: <ul style="list-style-type: none">• Camera With Landscape Adapter• Rear Tower Cover• Illumination Boards (2)• Cabling Harness• USB Cable• Service Label

Kit Parts



IMPORTANT The USB cable included in the kit is the longest length permitted for USB 3.0. Cable extensions are not permissible. If used, the camera may not operate properly.

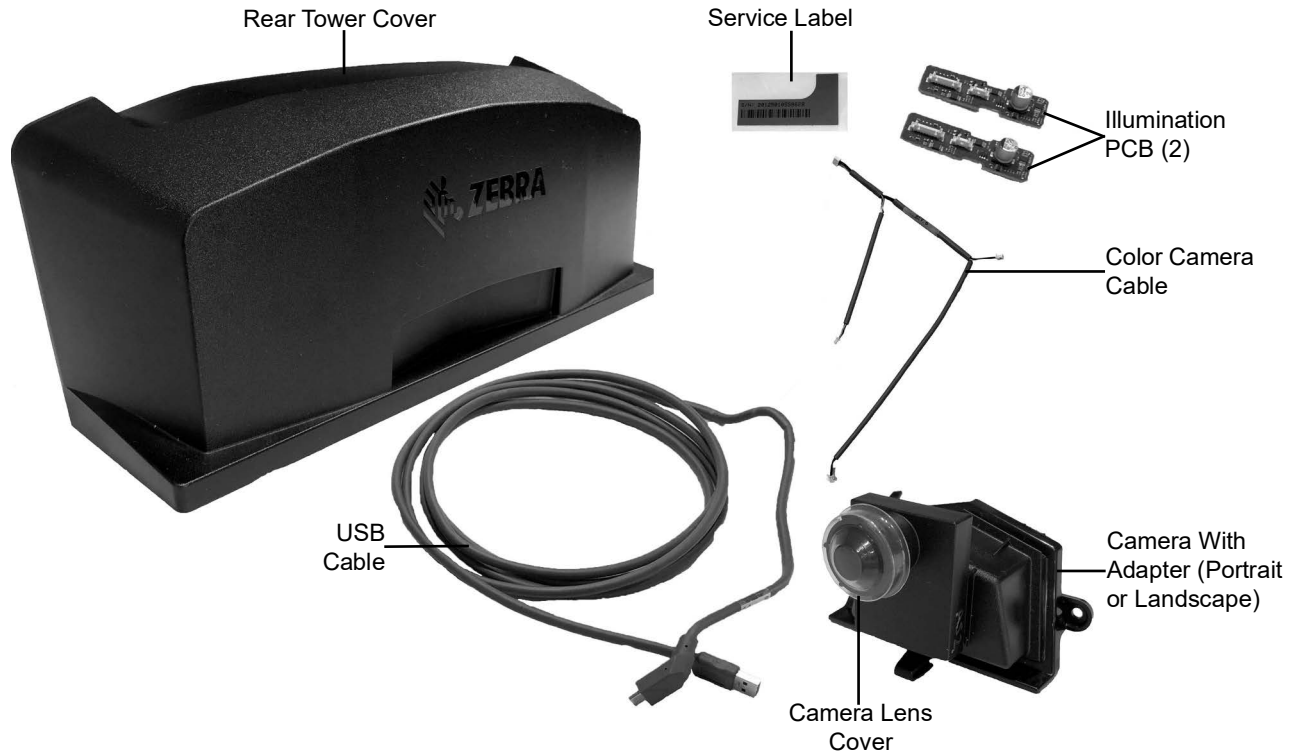

Figure 6-1 Kit Parts

Installing the Color Camera



IMPORTANT Color camera installation must be performed in a clean environment to prevent dust or any foreign matter ingress into the optical chamber.

MP7000 Inner Housing

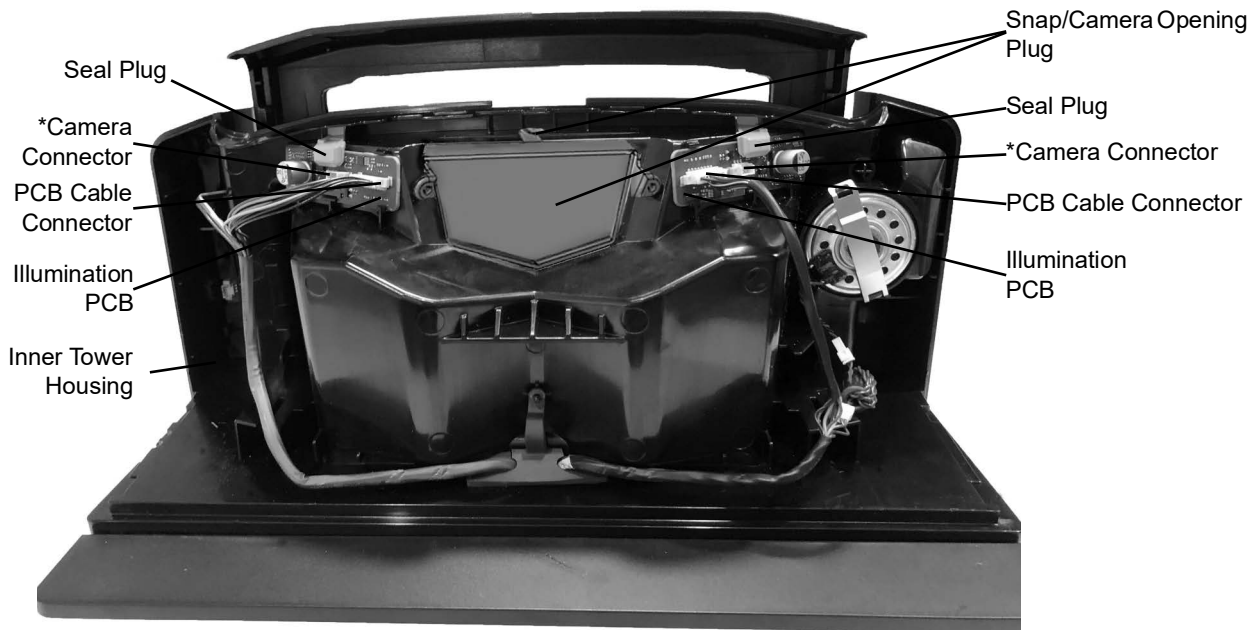

***Note:** Camera connectors are only included on PCBs used with the color camera.

Figure 6-2 MP7000 Inner Housing Parts

To install the color camera:

1. Disconnect the MP7000 power supply and POS interface cable.
2. Remove the platter from the MP7000.
3. Air-blow the rear tower cover (to remove any dust build-up).
4. Detach rear tower cover by lifting the center of the cover with your thumb to disengage from the tower housing and remove.
5. Air-blow the inner tower housing.
6. Pull the left yellow plastic seal plug straight out to remove.
7. Disconnect the PCB cable connector from the illumination PCB. Gently pull the connector body. Do not pull the wires.
8. Remove the illumination PCB. Lift the PCB tab with a finger while tipping the top of the illumination PCB away from the housing.



NOTE There is a left and right Illumination PCB. The placement of the PCB tab is the key for the correct fit for each illumination PCB.

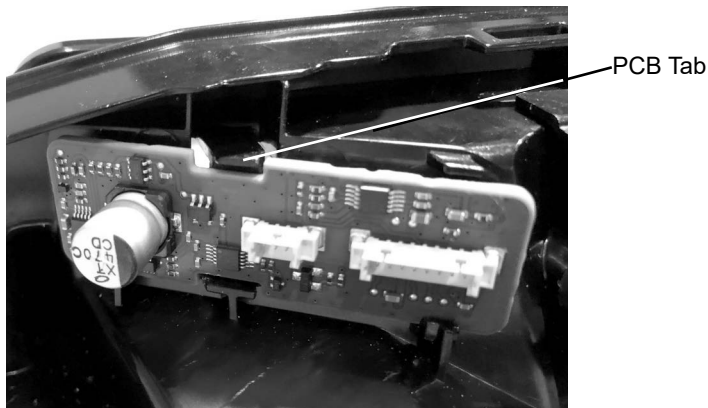

Figure 6-3 PCB Lock-in Tab

9. Insert the new illumination PCB to the left side, bottom edge first. Lift the PCB tab with a finger and tilt the PCB back against the housing until tab snaps.
10. Re-install the corresponding seal plug.
11. Repeat 6 through 10 on the right side of the device.
12. Re-connect the PCB cable connector to the illumination PCB on both sides of the device.
13. Disengage the snap and remove camera opening plug.
14. Remove the clear plastic lens cover from the color camera and snap in camera housing into place.
15. The color camera cable has four connectors:
 - a. Connect the 3-pin connector on the longest branch to the User Interface PCB.
 - b. Connect one 3-pin connector to each illumination PCB.
 - c. Connect the 5-pin connector to the color camera.
16. Route the camera cable through guiding ribs 1, 2, and 3 and under the cable retainer tab.



17. Attach the USB cable and route it under the cable retainer tab, through guiding ribs 1 and 2 to the side of the device.

✓ **NOTE** The USB cable only connects correctly in one orientation. When connected upside down, the camera does not operate and the cable interferes with the rear housing.

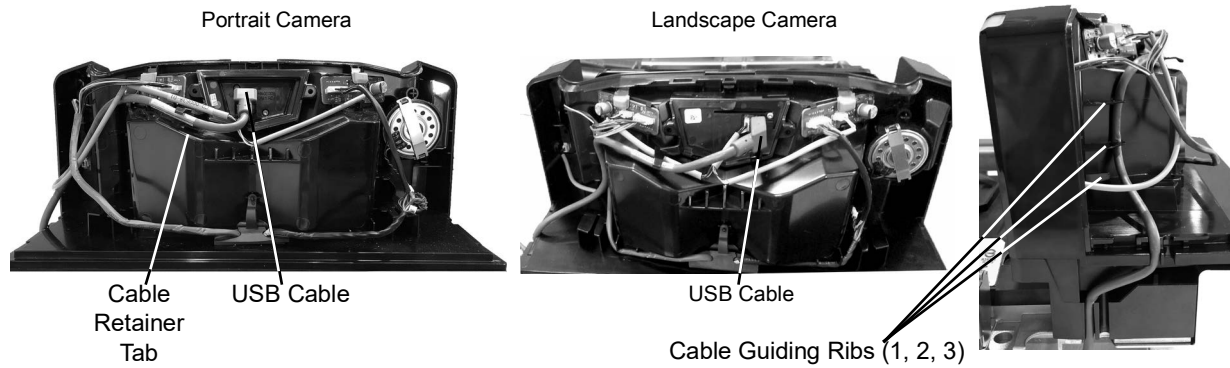

18. Install the new rear tower cover.

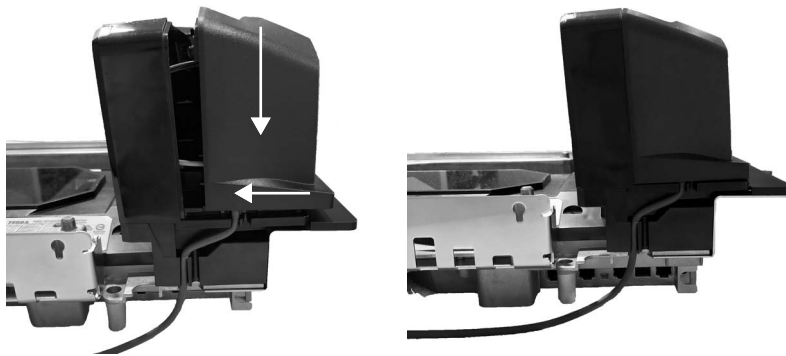

Figure 6-4 *Replace the Rear Cover*

19. Attach the service label next to the manufacturing label under the platter.

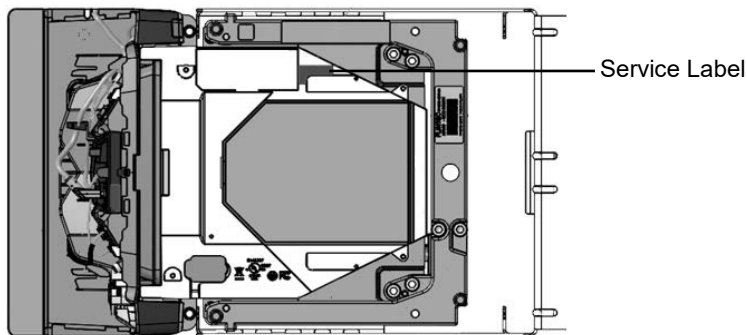

Figure 6-5 *Service Label Placement Under Platter*

20. Replace the platter.

Color Camera Uses

Color camera configurations are best used in conjunction with the Zebra MXC7000-SDK. This provides Zebra enhanced functionality, beyond the standard UVC functionality. These enhancements are designed to support new retailer requirements such as, loss-prevention, item recognition, video-surveillance and more.

When the color camera is installed and connected to a USB host, the camera LED on the front right panel of the device is on (green). When the color camera is disconnected from a USB host or installed incorrectly the LED is off.

The color camera can also be used as an industry standard UVC camera. Any UVC application functions - no Zebra software or drivers required.

The MXC7000 color camera supports many modes of operation. Refer to the MXC7000 SDK for additional details.

CHAPTER 7 123SCAN AND SOFTWARE TOOLS

Introduction

This chapter briefly describes the Zebra software tools available for customizing scanner operation.

123Scan

123Scan is a software tool that simplifies scanner setup and more.

Intuitive enough for first time users, the 123Scan wizard guides users through a streamlined setup process. Settings are saved in a configuration file that can be printed as a single programming barcode for scanning, emailed to a smart phone for scanning from its screen, or downloaded to the scanner using a USB cable.

Through 123Scan a user can:

- Configure a scanner using a wizard
 - Program the following scanner settings:
 - Beeper tone / volume settings
 - Enable / disable symbologies
 - Communication settings
 - Modify data before transmission to a host using:
 - Advanced Data Formatting (ADF) - Scan one barcode per trigger pull
- Load parameter settings to a scanner via:
 - Barcode scanning:
 - Scan a paper barcode
 - Scan a barcode from a PC screen
 - Scan a barcode from a smart phone screen
 - Download over a USB cable:
 - Load settings to one scanner
 - Stage up to 10 scanners simultaneously

- Validate scanner setup:
 - View scanned data within the utility's Data View screen
 - Capture an image and save to a PC within the utility's Data View screen
 - Review settings using the Parameter Report
 - Clone settings from an already deployed scanner
- Upgrade scanner firmware:
 - Load settings to one scanner
 - Stage up to 10 scanners simultaneously with a power USB hub
- View statistics such as:
 - Asset tracking information
 - Time and usage information
 - Barcodes scanned by symbology
 - Communication diagnostics
- Generate the following reports:
 - Barcode Report - Programming barcode, included parameter settings, and supported scanner models
 - Parameter Report - Lists parameters programmed within a configuration file
 - Activity Report - Lists activities performed on a scanner(s)
 - Inventory Report - Lists scanner asset tracking information
 - Validation Report - Printout of scanned data
 - Statistics Report - Lists all statistics retrieved from the scanner

For more information go to: <http://zebra.com/123Scan>.

Communication with 123Scan

Use a USB cable to connect the scanner to a Windows host computer running 123Scan.

123Scan Requirements

- Host computer running Windows
- Scanner
- USB cable

123Scan Information

For more information on 123Scan, go to: <http://zebra.com/123Scan>.

For a 1 minute tour of 123Scan, go to: <http://zebra.com/ScannerHowToVideos>.

To download any of the following free tools, go to: <http://zebra.com/scannersoftware>.

- 123Scan configuration utility (described in this chapter)
- How-to-videos

Scanner SDK, Other Software Tools, and Videos

Tackle all your scanner programming needs with our diversified set of software tools. Whether you need to simply stage a device, or develop a fully featured application with image and data capture as well as asset management, these tools help you every step of the way.

To download any of the following free tools, go to: <http://zebra.com/scannersoftware>.

- 123Scan configuration utility
- SDKs
 - Scanner SDK for Windows
 - Scanner SDK for Linux
 - Scanner SDK for Android
- Drivers
 - OPOS driver
 - JPOS driver
 - TWAIN driver
 - USB CDC driver
 - Virtual COM port driver
- Scanner Management Service (SMS) for Remote Management
 - Windows
 - Linux
 - IBM 4690
- How-To-Videos
- User documentation.



NOTE For a list of SDK supported scanner functionality by communication protocol, see [Appendix E, Communication Protocol Functionality](#).

Advanced Data Formatting (ADF)

Advanced Data Formatting (ADF) is a means of customizing data from before transmission to the host device. Use ADF to edit scan data to suit your host's requirements. With ADF you scan one barcode per trigger pull. ADF is programmed using 123Scan.

For an ADF tutorial and a 123Scan programming example, go to the 123Scan section of our How To Videos: <http://zebra.com/ScannerHowToVideos>.

For additional information, refer to the *Advanced Data Formatting Programmer Guide*.

APPENDIX A MAINTENANCE, TROUBLESHOOTING, AND ERROR CODES

Introduction

This chapter provides error/warning codes, troubleshooting, and maintenance information.

- [Maintenance on page A-1](#)
- [Troubleshooting on page A-2](#)
- [Diagnostic LED 7-segment Display - Error and Warning Codes on page A-2](#)
- [General Error and Warning Codes on page A-4](#)
- [LED Display Notes on page A-2](#)
- [Scale Warning Codes on page A-6](#)

Maintenance

Clean the housing and glass with a damp cloth and, if necessary, a non-ammonia based detergent. Do not allow any abrasive material to touch the screen.

Troubleshooting

Diagnostic LED 7-segment Display - Error and Warning Codes



IMPORTANT The information in [Table A-1](#) and [Table A-2](#) are for reference only. Contact your service provider for any error or warning conditions.

The MP70XX includes a one character LED display inside the scanner vertical window. This display provides status and troubleshooting information, as well as scale legal parameters during calibration (only configurations with a scale).

Status, warning, and error information are communicated via letter(s) and number(s) scrolled one character at a time in the LED display. When a message completes, the display pauses for two seconds, then repeats the sequence continuously.

See [Chapter 4, Scale Calibration \(For Models With a Scale\)](#) for detailed calibration information, including calibration errors and warnings.

LED Display Notes

- - (dash) indicates normal operating mode.
- Scale calibration information (see [Table A-2 on page A-6](#)) has precedence over general warning messages but not over errors.
- Scrolling **CAL** (number of calibrations performed) and **PAR** (legal parameter) values display for scale verification (*electronic seal*).
- **Cxxx** and **Pxxx** scroll when the **Scale Zero** button is held for three or more seconds.
- An error message displays when a fault condition exists. A power cycle is required. Verify that the subsystems and auxiliary devices are operational.
- A warning message displays when a warning condition exists. The power sequence pauses until the issue is resolved.
- For scale firmware version # 1.04F (for applicable countries):
 - Scrolling **CAL** (number of calibrations performed) and **PAR** (legal parameter) values display for scale verification (*electronic seal*), and where required by country legislation, scale approved firmware version number.
 - **Cxxx** and **Pxxx** scroll when the **Scale Zero** button is held for three or more seconds, followed by **x.xx F** (determined by country legislation).

Status Indicator Light

The status indicator light on the MP70XX has three types of displays.

- Green: The unit is operating normally.
- Blinking Red/Green: Indicates a warning. The unit continues to operate with possible performance degradation.
- Red (solid): Indicates a fault. The unit does not operate correctly unless the error is resolved.

Troubleshooting Assistance

If an MP70XX displays any of the LED display codes preceded with an **E** the unit will not operate correctly unless the error is resolved. For LED display codes preceded with a **U** the unit will continue to operate, although with possible performance degradation. Under any circumstance it is recommended to review basic hardware installation, and software configuration prior to contacting a Zebra approved Service Provider. It is often possible to restore unit function by following the steps below.

1. Remove power from the MP70XX, POS equipment, and any auxiliary devices (hand-held scanners/cradles).
2. Inspect external cables including POS, auxiliary hand-held devices, and optional pole display (scale units only) for proper seating in their respective connectors.
3. Inspect internal cables:
 - a. Scale Units Only - remove platter and confirm the scale connection cable is fully seated within the connector in the scale unit - if necessary remove the unit from the counter-top.

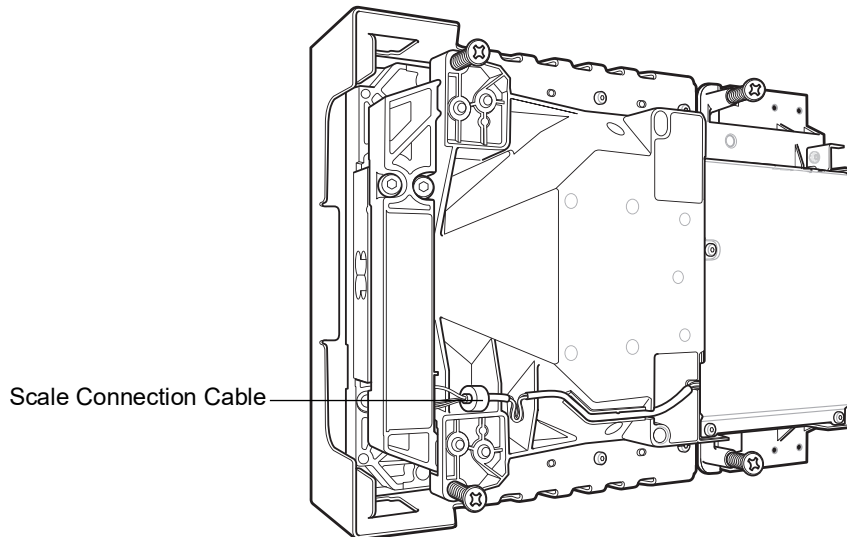

Figure A-1 Bottom View, Cover On

4. Detach tower cover by lifting the center of the cover with your thumb to disengage from the tower housing and remove.

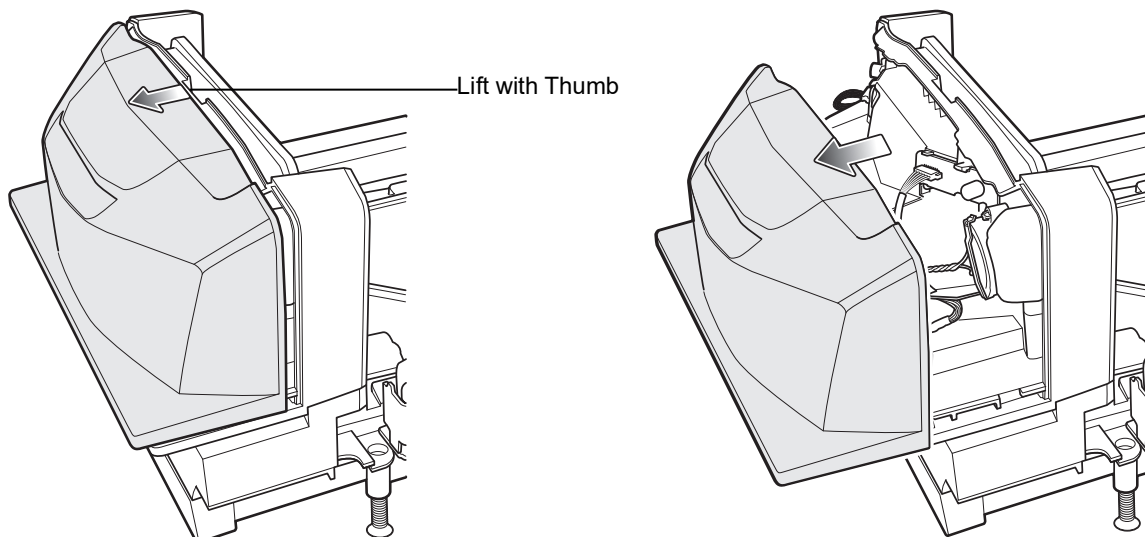

Figure A-2 Removing the Tower Cover

5. Inspect the cable connectors on the UI board (1), left Illumination board (1), right Illumination board (1) and speaker assembly (1), ensuring they are completely seated within their respective connectors. For units with the optional CSS, ensure the USB cable within the tower cover is routed inside of the tower cover and fully inserted into the side USB.

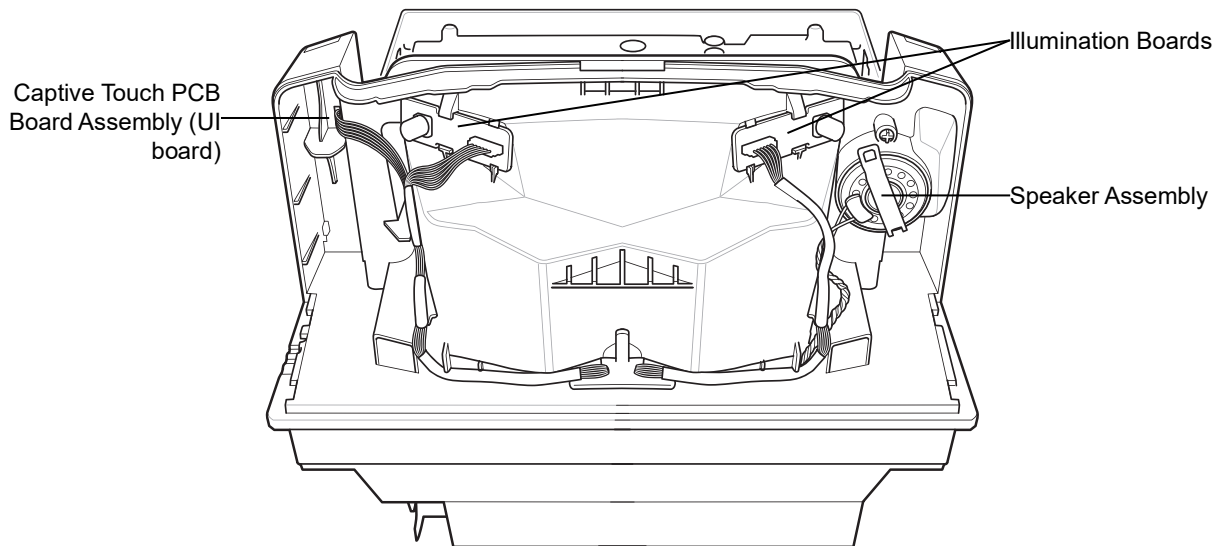

Figure A-3 Tower Assembly, Cover Off

6. Replace the tower cover.
7. Replace the platter on the unit.
8. Remove any objects from the platter, or near the unit and re-apply power to the MP70XX and attached equipment (POS, hand-held scanner).
9. Wait for the unit to boot, and listen for start-up audio indicators.
10. If the LED display codes persist contact your Zebra qualified Service Provider.

General Error and Warning Codes

Table A-1 LED Display Error and Warning Codes

LED Display Code	Error/Warning Indication
Errors (E)	
E21	Illumination failed
E26	Image Capture Hardware (HW assist) failure
E28	Digital Audio Playback failure
Warnings (U)	
U1	Diagnostic Test Flag (internal only)
U2	Illumination Current Limit warning
U3	Horizontal Left Current Limit warning

Table A-1 LED Display Error and Warning Codes (Continued)

LED Display Code	Error/Warning Indication
U5	Horizontal Right Current Limit warning
U6	Vertical Left Current Limit warning
U8	Vertical Right Current Limit warning
U9	Image Sensor Warning (either)
U10	Vertical Image Sensor warning
U11	Horizontal Image Sensor warning
U16	Sensormatic EAS Offline warning
U17	Host Protocol warning
U18	Left Channel IR (object detection) failure
U25	Right Channel IR (object detection) failure
U27	User Interface (button interface) failure
U29	EAS Communication Error
U30	Center Channel IR (object detection) failure
U31	Indicates that the Sensormatic control box has an internal high voltage fault. The user should turn off the Sensormatic control box (EAS tags will not be detected or deactivated).

Scale Warning Codes

The warning codes listed in [Table A-2](#) display on the 7-segment display.

Table A-2 Scale Fault Codes

Warning Code	Warning Type	Description
U12	Scale Failed to Zero on Scale Zero Button Press	<p>The scale failed to find a zero weight reference when the Scale Zero button was pressed. The scale will zero if the weight on the platter is within +/- 2% of maximum weight measurement capacity, and stable (i.e., no motion on platter). This is +/- 0.6 lb, or +/- 0.3 kg depending on the units of measure programmed.</p> <p>The allowable <i>zeroing weight limit</i> of 0.6 lb and 0.3 kg is configurable. Refer to the <i>MP7000 Scanner Scale Barcode Programming Guide</i> (p/n MN-002912-xx) for the Maximum Scale Zeroing Weight Limit parameter.</p> <p>If operation fails, the user must clear it by pressing the Scale Zero button.</p>
U13	Scale Outside of Zero Drift Threshold	<p>The zero reference drifted beyond 80% of the initial zero setting range of -5% to +15% (i.e., -0.9 lb to +3.9 lb or -0.4 kg to +1.9 kg) maximum weight measurement capacity, relative to the zero weight reference found at a no load legal scale calibration.</p> <p>This is an advisory indicating that the scale will soon require a re-calibration.</p> <p>It can sometimes be cleared by scanning the Scale Reset parameter barcode, or re-powering the scale, or leaving the scale on from a cold power start for more than 10 minutes. If this persists, re-calibrate the scale.</p> <p>NOTE 1This fault code annunciates if a weight greater than 4.5 lb, or 2.25 kg, is left on the weighing surface while the scale comes up from a reset or cold power start. If this occurs, clear it by removing the weight.</p> <p>NOTE 2The fault code annunciates if the scale resets, or upon a cold reset of the MP70XX system, and the platter is not installed. It clears when the platter is reinstalled.</p>
U14	Scale is Out of Calibration	<p>The scale must be legally calibrated before it becomes operational. There are three reasons:</p> <ul style="list-style-type: none"> • The scale can no longer find a zero weight reference: at power up; after a weight is removed from the platter during normal operation; or, when pressing the Scale Zero button. <p>NOTEThe scale software does not remove the scale from calibration under these conditions if it was already legally calibrated. This is a very visible condition for a user to troubleshoot. The Scale Display does not show 0 (zero) reading from power-up, or after pressing the Scale Zero button with no load on the platter.</p> <ul style="list-style-type: none"> • A new scale was installed in the MP70XX. • A new MP70XX shipped from a factory to an installation that requires calibration at place of scale use.

Table A-2 Scale Fault Codes (Continued)

Warning Code	Warning Type	Description
U15	Scale Offline	This is an internal error in the MP70XX scanner/scale unit and in most cases a <i>Scale Communication Error U22</i> is reported before this error.
U22	Scale Communication Error	This is a failed communication between the MP70XX scanner PCB and the scale device. There are three issues that can cause this fault condition: <ul style="list-style-type: none"> • Circuitry on the MP70XX scanner PCB is failed. • Internal cable between scanner PCB and the scale device is faulty. • Internal circuitry on the scale device is faulty.
U23	Scale Display Communication Error	This is a failed communication between the MP70XX PCB and the Scale Display. There are three issues that can cause this fault condition: <ul style="list-style-type: none"> • The Scale Display configuration parameter is enabled and no Scale Display is connected to the MP70XX scanner/scale. Refer to the <i>MP7000 Scanner Scale Barcode Programming Guide</i> (p/n MN-002912-xx) for scale parameters. • Display circuitry on the MP70XX PCB failed. • The Scale Display cable between the MP70XX PCB and the Scale Display is faulty, or the internal circuitry of the Scale Display is faulty. The Scale Display and cable are a single Line Replaceable Assembly (FRU*). <p>NOTE*In most applications, p/n MX201-SR00004ZZWW can be ordered as a replacement.</p>
U24	Scale Motion Fault	This condition occurs when the scale detects constant motion on the weighing surface for an extended duration of time. This is a <i>latched fault</i> , meaning the MP70XX needs to be powered off, the problem fixed, and the MP70XX powered back on. There are one of three reasons for this fault condition. <ol style="list-style-type: none"> a. The scale was improperly installed, or is mechanically bent or damaged where it cannot achieve a stable weight condition. b. The scale or the platter is pressed up against a fixed object and its free motion is inhibited. c. Debris is lodged under one or more of the over travel stop screws. <p>NOTEIf this occurs, the recommendation in most cases, is to remove and re-seat the scale. The scale should be replaced if the condition persists.</p>

APPENDIX B TECHNICAL SPECIFICATIONS

Table B-1 *MP70XX Technical Specifications*

Item	Description
Physical Characteristics	
Dimensions	
Platter Option	
Short (no scale available)	Length: 13.9 in. (351.0 mm) Width: 11.5 in. (292.0 mm) Depth: 4.0 in. (102.0 mm) Height above platter: 5.1 in. (129.5 mm) max
Medium scanner and scanner/scale	Length: 15.7 in. (398.0 mm) Width: 11.5 in. (292.0 mm) Depth: 4.0 in. (102.0 mm) Height above platter: 5.1 in. (129.5 mm) max
Long scanner and scanner/scale	Length: 20.0 in. (506.0 mm) Width: 11.5 in. (292.0 mm) Depth: 4.0 in. (102.0 mm) Height above platter: 5.1 in. (129.5 mm) max
Weight NOTE Weight includes platter, but not cables or power supply.	Short: 12.1 lb / 5.5 kg Medium (no scale): 12.6 lb / 5.7 kg Medium (with scale): 15.7 lb / 7.1 kg Long (no scale): 14.6 lb / 6.6 kg Long (with scale): 17.6 lb / 8.0 kg

B - 2 MP7000 Scanner Scale Integrator Guide

Table B-1 *MP70XX Technical Specifications*

Item	Description
Power	<ul style="list-style-type: none"> • 12VDC from POS interface cable (USB PowerPlus, RS-232 or RS-485) • Power Supply P/N: PWR-BGA12V50W0WW - 100-240V~, 50/60Hz, 2.4A, 12VDC, 4.16A • Idle Mode 3.0 W (typical) • Active Mode 5.5 (typical), 6.0 W (maximum) <p>Typical Usage Power = 3.5 W, assuming 18% Active, and 82% Idle</p> <p>Note: MP7000 configurations that include color camera enhancements will see an additional 170 mW in power consumption due to the white LEDs. Typical Usage Power = 3.7 W. This increase is based on a color camera exposure time of 1 millisecond.</p>
Data Ports	<ul style="list-style-type: none"> • One shared POS port for USB / RS-232 / IBM RS-485 • Three USB peripheral ports • Two powered RS-232 peripheral ports • Checkpoint interlock port • Scale Display port • Internal scale port
Scale	<ul style="list-style-type: none"> • 30 lb. in 0.01 lb. increments/15 kg in 5 g increments • Maximum static weight: 300 lb./136 kg • Single-cable and dual-cable protocols • Compatible with Mettler price computational scales • Options: <ul style="list-style-type: none"> • Dual-interval Zebra scale <ul style="list-style-type: none"> • 0-12 lb. in 0.005 lb increments and 12-30 lb in 0.01 lb increments • 0-6 kg in 2 g increments and 6-15 kg in 5 g increments • Single-head and dual head remote scale displays <ul style="list-style-type: none"> • Dual heads rotate fully independently for widest viewing angles on the market
Horizontal Platter	<ul style="list-style-type: none"> • Sapphire glass • Produce flip-up bar on scale models

Table B-1 MP70XX Technical Specifications

Item	Description
User Interface	<ul style="list-style-type: none"> • Soft touch capacitive pads (no buttons to break or wear out, no debris entry) • Large two-color LED (feedback for cashiers and self-checkout) • Beeper (adjustable volume and beep tones) • Four programmable buttons • Camera Snapshot (collecting images for various applications)
Imaging Technology	
Type	Multiple CMOS Array Imager
Illumination	Hyper/deep red, controlled by item detection system
Sides Read/Scan Zone	All sides; 720° coverage
1D/2D Symbologies	2 of 5 (Interleaved, Discrete, IATA, Chinese); Bookland EAN; Code 128; Code 39 (standard, full ASCII); Code 93; EAN128; EAN-13; EAN-8; GS1 DataBar (Omnidirectional, Truncated, Stacked); GS1 DataBar Expanded coupon; GS1 DataBar Limited; GS1 DataBar Expanded (regular, stacked); JAN 8; JAN-13; MSI/Plessey; TLC-39; Trioptic Code 39; UPC-A; UPC-E; UPC-E1; 2-digit Supplementals; 5-digit Supplemental; Codabar; Pharmacode (Code 32)
2D Symbologies	Aztec; Datamatrix; MicroPDF417; MicroQR Code; PDF417; QR Code; Han Xin
Digimarc	Digimarc barcode
Performance Characteristics	
User Environment	
Operating Temperature	32° F to 104° F / 0° to 40° C
Storage Temperature	-40° F to 158° F / -40° C to 70° C
Humidity	20% to 95% (non-condensing)
Ambient Light (for scanning)	Artificial Light: 0 - 450 Foot-candles (4,842 LUX) Sunlight: 0 - 8,000 Foot-candles (86,080 LUX)
Environmental Sealing	IP5X
Color Camera	
Image Sensor	2.3 Megapixel
Output Images Over Dedicated USB 3.0 Type-A Interface	Super-Speed USB providing 5 Gbps data rate Camera USB cable is 3 meter long Camera supports UVC (USB Video Class) command set

B - 4 MP7000 Scanner Scale Integrator Guide

Table B-1 *MP70XX Technical Specifications*

Item	Description
Utilities and Management	
123Scan	Programs scanner parameters, upgrades firmware, displays scanned barcode data, scanning statistics, battery health, asset data and prints reports. http://zebra.com/123scan
Symbol Scanner SDK	Generates a fully-featured scanner application, including documentation, drivers, test utilities and sample source code. http://zebra.com/scannersdkforwindows
Scanner Management Service (SMS)	Remotely manages your Zebra scanner and queries its asset information. http://zebra.com/sms
Loss Prevention	EAS Checkpoint supported: Checkpoint interlock via optional cable Sensormatic supported Zebra Scale Platter: Integrated horizontal and vertical platter for increased weighing area
Peripherals and Accessories	
Customer Side Scanner (CSS)	Allows self-scanning of barcodes on mobile phones, loyalty cards, and impulse buy items
Scale Display	Enables indication of zero status and gross weight indication for both customer and operator.
Scale (Optional)	Both single-interval and dual-interval options are available
Checkpoint Interlock Cable Assembly Kit	p/n MX306-SA00WW - Horizontal Checkpoint antenna p/nMX307-SA00WW - Vertical Checkpoint antennna
Width Extender (trim piece)	Only for MP70XX long versions; p/n: MX303-RAIL
Color Camera	Color Camera module can be added to any standard MP7000 manufactured after April 1, 2020 with the listed upgrade kits. MXC-7000-P: Color camera portrait upgrade kit MXC-7000-L: Color camera landscape upgrade kit

APPENDIX C ASCII CHARACTER SETS

✓ **NOTE** For the Keyboard Wedge Interface, Code 39 Full ASCII interprets the barcode special character (\$ + % /) preceding a Code 39 character and assigns an ASCII character value to the pair. For example, if you enable Code 39 Full ASCII and scan **+B**, it transmits as **b**, **%J** as **?**, and **%V** as **@**. Scanning **ABC%I** outputs the keystroke equivalent of **ABC >**.

Table C-1 ASCII Character Set

ASCII Value (Prefix/Suffix Value)	Full ASCII Code 39 Encode Char	Keystroke	ASCII Character (Applies to RS-232 Only)
1000	%U	CTRL 2	NUL
1001	\$A	CTRL A	SOH
1002	\$B	CTRL B	STX
1003	\$C	CTRL C	ETX
1004	\$D	CTRL D	EOT
1005	\$E	CTRL E	ENQ
1006	\$F	CTRL F	ACK
1007	\$G	CTRL G	BELL
1008	\$H	CTRL H/ BACKSPACE ¹	BCKSPC
1009	\$I	CTRL I/ HORIZONTAL TAB ¹	HORIZ TAB
1010	\$J	CTRL J	LF/NW LN
1011	\$K	CTRL K	VT
1012	\$L	CTRL L	FF
1013	\$M	CTRL M/ ENTER ¹	CR/ENTER

¹The keystroke in bold transmits only if you enabled Function Key Mapping (refer to the *MP7000 Scanner Scale Barcode Programming Guide*). Otherwise, the unbold keystroke transmits.

Table C-1 ASCII Character Set (Continued)

ASCII Value (Prefix/Suffix Value)	Full ASCII Code 39 Encode Char	Keystroke	ASCII Character (Applies to RS-232 Only)
1014	\$N	CTRL N	SO
1015	\$O	CTRL O	SI
1016	\$P	CTRL P	DLE
1017	\$Q	CTRL Q	DC1/XON
1018	\$R	CTRL R	DC2
1019	\$S	CTRL S	DC3/XOFF
1020	\$T	CTRL T	DC4
1021	\$U	CTRL U	NAK
1022	\$V	CTRL V	SYN
1023	\$W	CTRL W	ETB
1024	\$X	CTRL X	CAN
1025	\$Y	CTRL Y	EM
1026	\$Z	CTRL Z	SUB
1027	%A	CTRL [ESC
1028	%B	CTRL \	FS
1029	%C	CTRL]	GS
1030	%D	CTRL 6	RS
1031	%E	CTRL -	US
1032	Space	Space	Space
1033	/A	!	!
1034	/B	"	"
1035	/C	#	#
1036	/D	\$	\$
1037	/E	%	%
1038	/F	&	&
1039	/G	'	'
1040	/H	((
1041	/I))

¹The keystroke in bold transmits only if you enabled Function Key Mapping (refer to the *MP7000 Scanner Scale Barcode Programming Guide*). Otherwise, the unbold keystroke transmits.

Table C-1 ASCII Character Set (Continued)

ASCII Value (Prefix/Suffix Value)	Full ASCII Code 39 Encode Char	Keystroke	ASCII Character (Applies to RS-232 Only)
1042	/J	*	*
1043	/K	+	+
1044	/L	,	,
1045	-	-	-
1046	.	.	.
1047	/o	/	/
1048	0	0	0
1049	1	1	1
1050	2	2	2
1051	3	3	3
1052	4	4	4
1053	5	5	5
1054	6	6	6
1055	7	7	7
1056	8	8	8
1057	9	9	9
1058	/Z	:	:
1059	%F	;	;
1060	%G	<	<
1061	%H	=	=
1062	%I	>	>
1063	%J	?	?
1064	%V	@	@
1065	A	A	A
1066	B	B	B
1067	C	C	C
1068	D	D	D
1069	E	E	E

¹The keystroke in bold transmits only if you enabled Function Key Mapping (refer to the *MP7000 Scanner Scale Barcode Programming Guide*). Otherwise, the unbold keystroke transmits.

Table C-1 ASCII Character Set (Continued)

ASCII Value (Prefix/Suffix Value)	Full ASCII Code 39 Encode Char	Keystroke	ASCII Character (Applies to RS-232 Only)
1070	F	F	F
1071	G	G	G
1072	H	H	H
1073	I	I	I
1074	J	J	J
1075	K	K	K
1076	L	L	L
1077	M	M	M
1078	N	N	N
1079	O	O	O
1080	P	P	P
1081	Q	Q	Q
1082	R	R	R
1083	S	S	S
1084	T	T	T
1085	U	U	U
1086	V	V	V
1087	W	W	W
1088	X	X	X
1089	Y	Y	Y
1090	Z	Z	Z
1091	%K	[[
1092	%L	\	\
1093	%M]]
1094	%N	^	^
1095	%O	_	_
1096	%W	'	'
1097	+A	a	a

¹The keystroke in bold transmits only if you enabled Function Key Mapping (refer to the *MP7000 Scanner Scale Barcode Programming Guide*). Otherwise, the unbold keystroke transmits.

Table C-1 ASCII Character Set (Continued)

ASCII Value (Prefix/Suffix Value)	Full ASCII Code 39 Encode Char	Keystroke	ASCII Character (Applies to RS-232 Only)
1098	+B	b	b
1099	+C	c	c
1100	+D	d	d
1101	+E	e	e
1102	+F	f	f
1103	+G	g	g
1104	+H	h	h
1105	+I	i	i
1106	+J	j	j
1107	+K	k	k
1108	+L	l	l
1109	+M	m	m
1110	+N	n	n
1111	+O	o	o
1112	+P	p	p
1113	+Q	q	q
1114	+R	r	r
1115	+S	s	s
1116	+T	t	t
1117	+U	u	u
1118	+V	v	v
1119	+W	w	w
1120	+X	x	x
1121	+Y	y	y
1122	+Z	z	z
1123	%P	{	{
1124	%Q	 	
1125	%R	}	}

¹The keystroke in bold transmits only if you enabled Function Key Mapping (refer to the *MP7000 Scanner Scale Barcode Programming Guide*). Otherwise, the unbold keystroke transmits.

Table C-1 ASCII Character Set (Continued)

ASCII Value (Prefix/Suffix Value)	Full ASCII Code 39 Encode Char	Keystroke	ASCII Character (Applies to RS-232 Only)
1126	%S	~	~
1127			Undefined
7013			ENTER

¹The keystroke in bold transmits only if you enabled Function Key Mapping (refer to the *MP7000 Scanner Scale Barcode Programming Guide*). Otherwise, the unbold keystroke transmits.

Table C-2 ALT Key Character Set

ALT Keys	Keystroke
2064	ALT 2
2065	ALT A
2066	ALT B
2067	ALT C
2068	ALT D
2069	ALT E
2070	ALT F
2071	ALT G
2072	ALT H
2073	ALT I
2074	ALT J
2075	ALT K
2076	ALT L
2077	ALT M
2078	ALT N
2079	ALT O
2080	ALT P
2081	ALT Q
2082	ALT R
2083	ALT S
2084	ALT T

Table C-2 ALT Key Character Set (Continued)

ALT Keys	Keystroke
2085	ALT U
2086	ALT V
2087	ALT W
2088	ALT X
2089	ALT Y
2090	ALT Z

Table C-3 GUI Key Character Set

GUI Key	Keystroke
3000	Right Control Key
3048	GUI 0
3049	GUI 1
3050	GUI 2
3051	GUI 3
3052	GUI 4
3053	GUI 5
3054	GUI 6
3055	GUI 7
3056	GUI 8
3057	GUI 9
3065	GUI A
3066	GUI B
3067	GUI C
3068	GUI D
3069	GUI E
3070	GUI F
3071	GUI G

Note: GUI Shift Keys - The Apple™ iMac keyboard has an apple key on either side of the space bar. Windows-based systems have a GUI key to the left of the left ALT key, and to the right of the right ALT key.

Table C-3 GUI Key Character Set (Continued)

GUI Key	Keystroke
3072	GUI H
3073	GUI I
3074	GUI J
3075	GUI K
3076	GUI L
3077	GUI M
3078	GUI N
3079	GUI O
3080	GUI P
3081	GUI Q
3082	GUI R
3083	GUI S
3084	GUI T
3085	GUI U
3086	GUI V
3087	GUI W
3088	GUI X
3089	GUI Y
3090	GUI Z

Note: GUI Shift Keys - The Apple™ iMac keyboard has an apple key on either side of the space bar. Windows-based systems have a GUI key to the left of the left ALT key, and to the right of the right ALT key.

Table C-4 *PF Key Character Set*

PF Keys	Keystroke
4001	PF 1
4002	PF 2
4003	PF 3
4004	PF 4
4005	PF 5
4006	PF 6
4007	PF 7
4008	PF 8
4009	PF 9
4010	PF 10
4011	PF 11
4012	PF 12
4013	PF 13
4014	PF 14
4015	PF 15
4016	PF 16

Table C-5 *F Key Character Set*

F Keys	Keystroke
5001	F 1
5002	F 2
5003	F 3
5004	F 4
5005	F 5
5006	F 6
5007	F 7
5008	F 8
5009	F 9
5010	F 10
5011	F 11
5012	F 12
5013	F 13
5014	F 14
5015	F 15
5016	F 16
5017	F 17
5018	F 18
5019	F 19
5020	F 20
5021	F 21
5022	F 22
5023	F 23
5024	F 24

Table C-6 *Numeric Key Character Set*

Numeric Keypad	Keystroke
6042	*
6043	+
6044	Undefined
6045	-
6046	.
6047	/
6048	0
6049	1
6050	2
6051	3
6052	4
6053	5
6054	6
6055	7
6056	8
6057	9
6058	Enter
6059	Num Lock

Table C-7 *Extended Key Character Set*

Extended Keypad	Keystroke
7001	Break
7002	Delete
7003	Pg Up
7004	End
7005	Pg Dn
7006	Pause
7007	Scroll Lock
7008	Backspace
7009	Tab
7010	Print Screen
7011	Insert
7012	Home
7013	Enter
7014	Escape
7015	Up Arrow
7016	Dn Arrow
7017	Left Arrow
7018	Right Arrow

APPENDIX D STANDARD PARAMETER DEFAULTS

✓ **NOTE** This guide includes limited parameter barcodes. For ALL MP70XX programming barcodes, refer to the *MP7000 Scanner Scale Barcode Programming Guide* (p/n MN-002912-xx).

Table D-1 *Parameter Defaults*

Parameter	Page Number
USB Device Type	
IBM Table-top USB	2-5
RS-232 Host Type	
Standard RS-232	2-22
RS-232 Device Port Configuration	
AUX 1 Sensormatic and AUX 2 RS-232 Scanner	2-35
Third Party Scale	
Disable Third Party Scale	2-47
Third Party Scale LED Pin - Active High	2-49
Third Party Scale Zero Pin - Active High	2-51
IBM Port Addresses	
None Selected	2-54
IBM Scale Port Addresses	
None Selected	2-58
Legal Scale Units	
Kilograms	4-13
Scale Display Configuration	
Disable Scale Display	4-16

Table D-1 *Parameter Defaults (Continued)*

Parameter	Page Number
Legal Scale Dampening Filter	
Low Vibration Sensitivity	4-18
Scale Pole Display Type	
Standard Pole Display Type	4-21

APPENDIX E COMMUNICATION PROTOCOL FUNCTIONALITY

Functionality Supported via Communication (Cable) Interface

[Table E-1](#) lists supported scanner functionality by communication protocol.

Table E-1 *Communication Interface Functionality*

Communication Interfaces	Functionality		
	Data Transmission	Remote Management	Image and Video Transmission
USB			
HID Keyboard Emulation	Supported	Not Available	Not Available
Simple COM Port Emulation	Not Available	Not Available	Not Available
CDC COM Port Emulation	Supported	Not Available	Not Available
SSI over CDC COM Port Emulation	Not Available	Not Available	Not Available
IBM Table-top USB	Supported	Supported	Not Available
IBM Hand-held USB	Supported	Supported	Not Available
USB OPOS Hand-held	Supported	Supported	Not Available
Symbol Native API (SNAPI) without Imaging Interface	Available	Supported	Imaging Available; Video Not Available
Symbol Native API (SNAPI) with Imaging Interface	Available	Supported	Imaging Available; Video Not Available
RS-232			
Standard RS-232	Supported	Not Available	Not Available
ICL RS-232	Supported	Not Available	Not Available
Fujitsu RS-232	Supported	Not Available	Not Available
Wincor-Nixdorf RS-232 Mode A	Supported	Not Available	Not Available

Table E-1 *Communication Interface Functionality (Continued)*

Communication Interfaces	Functionality		
	Data Transmission	Remote Management	Image and Video Transmission
Wincor-Nixdorf RS-232 Mode B	Supported	Not Available	Not Available
Olivetti ORS4500	Supported	Not Available	Not Available
Omron	Supported	Not Available	Not Available
CUTE	Supported	Not Available	Not Available
OPOS/JPOS	Supported	Not Available	Not Available
NCR	Supported	Not Available	Not Available
Datalogic	Supported	Not Available	Not Available
SSI	Not Available	Supported	Not Available
IBM 4690			
Hand-held Scanner Emulation (Port 9B)	Supported	Not Available	Not Available
Table-top Scanner Emulation (Port 17)	Supported	Supported	Not Available
Non-IBM Scanner Emulation (Port 5B)	Supported	Supported	Not Available

APPENDIX F STATISTICS

MP7 Statistics Definitions

Time and Usage

- Time Powered on Over Lifetime (#15013)-Total time, in seconds, the device has been running (powered on) over its lifetime. [Seconds]
- Power Up Count (#15011)-The number of times the device has been powered up over its lifetime. [Occurrences]
- Time Since Last Power Up (#15015)-Time, in seconds, the device has been running since the last time power was turned on. [Seconds]

Last Scanned Barcode

- Decode Time (#15402)-Time, in milliseconds, for the device to decode the last scanned barcode. [ms]
- Symbology Type (#15117)-Identifies the Symbology of the last decoded barcode. [Type]
- Content (#25004)-Displays the last decoded barcode (initial 25 characters of barcode). [ASCII]

Decode Time and Count

- Total Decode Count (#15109)-Total number of barcodes scanned, tallied across all Symbologies. For devices with connected peripheral scanners, includes barcodes scanned from the peripheral scanner(s). [Scans]
- Decode Count from Main Device (#15400)- Total number of barcodes scanned, tallied across all Symbologies, but only from Main Device. For example, if a system = a DS4308 connected to a MP7000 and the MP7000 is connected to the host. Only decodes from MP7000 are shown. [Scans]
- Decode Count from Attached Peripherals (#15107)- Total number of barcodes scanned, but only from peripheral scanner(s). For example, if a system = a DS4308 connected to a MP7000 and the MP7000 is connected to the host. Only decodes from DS4308 are shown. [Scans]

F - 2 MP7000 Scanner Scale Integrator Guide

- Decode Count by Symbology - Total number of barcodes scanned for each symbology shown in the table below.
 - Decode Count -Total barcodes scanned of this symbology. [Scans]
 - Decode Time – Avg = Average decode time for this symbology. [ms]
 - Decode Time – Min = Fastest decode time for this symbology. [ms]
 - Decode Time – Max = Longest decode time for this symbology. [ms]

Table F-1 *Decode Time and Count Statistic/Parameter Numbers*

Symbology	Decode Count*	Decode Time Avg*	Decode Time Min*	Decode Time Max*
UPC	#15421	#15426	#15424	#15425
EAN/JAN	#15428	#15433	#15431	#15432
Interleaved 2 of 5 Discrete 2 of 5 Chinese 2 of 5	#15449	#15454	#15452	#15453
Codabar	#15456	#15461	#15459	#15460
Code 11	#15477	#15482	#15480	#15481
Code 128	#15442	#15447	#15445	#15446
Code 39	#15439	#15440	#15438	#15439
Code 93	#15463	#15468	#15466	#15467
Composite	#15519	#15424	#15422	#15423
GS1 Databar	#15512	#15517	#15515	#15516
MSI	#15470	#15475	#15473	#15474
Datamatrix	#15491	#15496	#15494	#15495
PDF	#15484	#15489	#15487	#15488
Postal Codes	#15505	#15510	#15508	#15509
QR Code	#15498	#15503	#15501	#15502
Aztec	#15533	#15538	#15536	#15537
OCR	#15526	#15531	#15529	#15530
Maxicode	#15659	#15664	#15662	#15663
GS1 Datamatrix	#15673	#15678	#15676	#15677
GS1 QR Code	#15680	#15685	#15683	#15684
Coupon	#15666	#15671	#15669	#15670

* Excludes decode data from attached peripherals.

Table F-1 Decode Time and Count Statistic/Parameter Numbers (Continued)

Symbology	Decode Count*	Decode Time Avg*	Decode Time Min*	Decode Time Max*
Digimarc UPC	#15787	N/A	N/A	N/A
Digimarc EAN/JAN	#15798	N/A	N/A	N/A
Digimarc Other	#15776	N/A	N/A	N/A
Other 1D	#15540	#15545	#15543	#15544
Other 2D	#15547	#15552	#15550	#15551
Other	#15554	#15559	#15557	#15558

*** Excludes decode data from attached peripherals.**

Communication Diagnostics

- USB Reset Count (#15267)-Number of USB Resets. [Occurrences]
- USB Suspend Count (#15269)-Number of USB Suspend. [Occurrences]
- USB Resume Count (#15271)-Number of USB Resumes. [Occurrences]
- USB Enumeration Count (#15273)-Number of USB Enumerations. [Occurrences]
- USB Enumeration Count (Attached/Auxiliary Scanners) (#15279)-Total number of USB Enumerations from peripheral connected scanners. [Occurrences]
- Host protocol (#15275)-Indicates the state of the Host interface at time of poll. OK(0) or Fault(1) [List]
- Host protocol (#15277)-Number of times the Host interface was in a 'Fault' state. [Faults]

Illumination Diagnostics

- Illumination Fault Count (Any Source) (#15134)-Number of times a 'Fault' was detected on Illumination Sources 1 through 6. Note: If a 'Fault' exists on two Illumination Sources simultaneously, it will only be counted once. [Faults]
- Illumination Source 1 (Left Horizontal) State (#15136)-Indicates the state of Illumination Source. OK(0) or Fault: Over-Current(1), Fault: Stuck-On(2), or Fault: Stuck-Off(3). [List]
- Illumination Source 1 (Left Horizontal) Fault Count (#15141)-Number of times a 'Fault' was detected on the illumination Source. [Faults]
- Illumination Source 2 (Center Horizontal) – State (#15143)-Indicates the state of illumination Source. OK(0) or Fault: Over-Current(1), Fault: Stuck-On(2), or Fault: Stuck-Off(3). [List]
- Illumination Source 2 (Center Horizontal) - Fault Count (#15148)-Number of times a 'Fault' was detected on the illumination Source. [Faults]
- Illumination Source 3 (Right Horizontal) State (#15150)-Indicates the state of Illumination Source. OK(0) or Fault: Over-Current(1), Fault: Stuck-On(2), or Fault: Stuck-Off(3). [List]
- Illumination Source 3 (Right Horizontal) Fault Count (#15155)-Number of times a 'Fault' was detected on the illumination Source. [Faults]

- Illumination Source 4 (Left Vertical) State (#15157)-Indicates the state of Illumination Source. OK(0) or Fault: Over-Current(1), Fault: Stuck-On(2), or Fault: Stuck-Off(3). [List]
- Illumination Source 4 (Left Vertical) Fault Count (#15162)-Number of times a 'Fault' was detected on the illumination Source. [Faults]
- Illumination Source 5 (Center Vertical) State (#15164)-Indicates the state of Illumination Source. OK(0) or Fault: Over-Current(1), Fault: Stuck-On(2), or Fault: Stuck-Off(3). [List]
- Illumination Source 5 (Center Vertical) Fault Count (#15169)-Number of times a 'Fault' was detected on the illumination Source. [Faults]
- Illumination Source 6 (Right Vertical) State (#15171)-Indicates the state of Illumination Source. OK(0) or Fault: Over-Current(1), Fault: Stuck-On(2), or Fault: Stuck-Off(3). [List]
- Illumination Source 6 (Right Vertical) Fault Count (#15176)-Number of times a 'Fault' was detected on the illumination Source. [Faults]
- Illumination Left PCB – State (#15178)-Indicates the state of the Left-Side-Aux-PCB. OK(0) or Fault(1). [List]
- Illumination Left PCB - Fault Count (#15180)-Number of times a 'Fault' was detected on the Left-Side-Aux-PCB. [Faults]
- Illumination Right PCB – State (#15182)-Indicates the state of the Right-Side-Aux-PCB. OK(0) or Fault(1). [List]
- Illumination Right PCB - Fault Count (#15184)-Number of times a 'Fault' was detected on the Right-Side-Aux-PCB. [Faults]

Sensor/Camera Diagnostics

- Decodes on All Sensors (#15186)-Number of decodes from any Window. [Scans]
- Decodes on Sensor 1(Vertical Window) (#15188)-Number of decodes from the Vertical Window. [Scans]
- Decodes on Sensor 2(Horizontal Window) (#15190)-Number of decodes from the Horizontal Window. [Scans]
- Sensor (Any Source) – State (#15192)-Indicates the state of the Imager-Sensors. OK(0) or Fault(1). [List]
- Sensor (Any Source) - Fault Count (#15197)-Number of times a 'Fault' was detected on the Imager-Sensors. [Faults]
- Sensor 1(Vertical Window) – State (#15199)-Indicates the state of the Vertical-Imager-Sensor. OK(0) or Fault(1). [List]
- Sensor 1(Vertical Window) - Fault Count (#15204)-Number of times a 'Fault' was detected on the Vertical-Imager-Sensors. [Faults]
- Sensor 2(Horizontal Window) – State (#15206)-Indicates the state of the Horizontal-Imager-Sensor. OK(0) or Fault(1). [List]
- Sensor 2(Horizontal Window) - Fault Count (#15211)-Number of times a 'Fault' was detected on the Horizontal-Imager-Sensors. [Faults]

Scale Diagnostics

- Scale is Calibrated (#15241)-Indicates if the scale is calibrated. Yes(0) or No(1). [List]
- Scale is Calibrated – Count (#15239)-Number of times the scale was calibrated. [Calibrations]
- Total "Get Weight" requests issued (#15213)-Number of times an application requested the 'Scale-Get-Weight' command. [Occurrences]
- Stable weight count on "Get Weight" (#15219)-Upon an application requesting 'Scale-Get-Weight' this is the number of times the scale was reporting 'Stable weight'. [Occurrences]
- Zero weight count "Get Weight" (#15217)-Upon an application requesting 'Scale-Get-Weight' this is the number of times the scale was reporting 'Zero weight'. [Occurrences]
- Unstable weight count on "Get Weight" (#15315)-Upon an application requesting 'Scale-Get-Weight' this is the number of times the scale was reporting 'Unstable'. [Occurrences]
- Slight overweight count on "Get Weight" (#15221)-Upon an application requesting 'Scale-Get-Weight' this is the number of times the scale was reporting 'Slight Overweight'. [Occurrences]
- Extreme overweight condition count "Get Weight" (#15231)-Upon an application requesting 'Scale-Get-Weight' this is the number of times the scale was reporting 'Extreme Overweight'. [Occurrences]
- Underweight count on "Get Weight" (#15215)-Upon an application requesting 'Scale-Get-Weight' this is the number of times the scale was reporting 'Underweight'. [Occurrences]
- Zero button press count during weight below Zero (#15223)-Upon pressing the 'Scale Zero Button' this is the number of times the scale was reporting 'Weight Below 0'. [Occurrences]
- Zero button press count during weight above Zero (#15225)-Upon pressing the 'Scale Zero Button' this is the number of times the scale was reporting 'Weight Above 0'. [Occurrences]
- Calibration Process – State (#15317)-There was an error during the Scale calibration process. [List]
- Calibration Process - Fault Count (#15233)-Number of times 'Scale-Calibration' failed. [Faults]
- Scale Communication – State (#15247)-Indicates the state of the scale interface. OK(0) or Fault(1). [List]
- Scale Communication - Fault Count (#15249)-Number of times the scale interface was at 'Fault'. [Faults]
- Scale Motion – State (#15255)-Indicates the scale detects that the weighing surface is not moving ("No Motion") and therefore can achieve a stable weight. OK(0) or Fault(1). [List]
- Scale Motion - Fault Count (#15257)-Number of times the scale was at 'Fault'. [Faults]
- Internal Scale – State (#15305)-Indicates the scale has encountered an internal 'Fault'. OK(0) or Fault(1). [List]
- Internal Scale - Fault Count (#15307)-Number of times the scale encountered an internal 'Fault'. [Faults]
- Zero Button Press – State (#15227)-Indicates if the last 'Scale Zero Button' press was successful. Successful(0) or Failed to Zero(1). [List]
- Zero Button Press - Fault Count (#15229)-Number of times the 'Scale Zero Button' press Failed to Zero. [Faults]
- Outside Zero Drift Threshold – State (#15235)-Indicates if the scale is currently within drift limits. OK(0) or Fault(1). [List]
- Outside Zero Drift Threshold - Fault Count (#15237)-Number of times the scale drift limits was at 'Fault'. [Faults]
- Pole Display – State (#15251)-Indicates the state of the scale pole display interface. OK(0) or Fault(1). [List]
- Pole Display - Fault Count (#15253)-Number of times the scale pole display interface was at 'Fault'. [Faults]

EAS Diagnostics

- EAS Soft Tags Deactivated (#15263)-Number of EAS Soft Tag Deactivations. [Occurrences]
- EAS Soft Tags Manually Deactivated (#15265)-Number of EAS Tag Deactivations by the Deactivation button. [Occurrences]
- EAS Hard Tags Detected (#15299)-Number of EAS Hard Tags Detected. [Occurrences]
- EAS – State (#15259)-Indicates the state of the EAS interface. OK(0) or Fault(1). [List]
- EAS - Fault Count (#15261)-Number of times the EAS interface was at 'Fault'. [Faults]

Object Detection Diagnostics

- Objects Detected (#15111)-Number of times the Wakeup System detected an object. [Occurrences]
- Right IR bank – State (#15281)-Indicates the state of the Right-Wakeup-System. OK(0) or Fault(1). [List]
- Right IR bank - Fault Count (#15283)-Number of times a 'Fault' was detected on the Right-Wakeup-System. [Faults]
- Left IR bank – State (#15113)-Indicates the state of the Left-Wakeup-System. OK(0) or Fault(1). [List]
- Left IR bank - Fault Count (#15115)-Number of times a 'Fault' was detected on the Left-Wakeup-System. [Faults]
- Center IR – State (#15309)-Indicates the state of the Center-Wakeup-System. OK(0) or Fault(1). [List]
- Center IR - Fault Count (#15311)-Number of times a 'Fault' was detected on the Center-Wakeup-System. [Faults]

Other Diagnostics

- FPGA – State (#15285)-Indicates the state of the FPGA-System. OK(0) or Fault(1). [List]
- FPGA - Fault Count (#15287)-Number of times a 'Fault' was detected on the FPGA-System. [Faults]
- PCBs (Buttons and LEDs) – State (#15289)-Indicates the state of the User-Interface-System. OK(0) or Fault(1). [List]
- PCBs (Buttons and LEDs) - Fault Count (#15291)-Number of times a 'Fault' was detected on the User-Interface-System. [Faults]
- Audio Hardware – State (#15293)-Indicates the state of the Audio-System. OK(0) or Fault(1). [List]
- Audio Hardware - Fault Count (#15295)-Number of times a 'Fault' was detected on the Audio-System. [Faults]

INDEX

Numerics

- 0.0 connector 1-16
- 123Scan 7-1
- 12V DC connector 1-17
- 7-segment display 1-15, 3-20, 4-2, 4-4, 4-5, 4-7, 4-8, 4-12, 5-2, 5-13, A-2, A-6

A

- accessory kits
 - antenna installation 3-21
 - color camera 6-1
 - leveling screws 1-12, 3-4, 3-12, 3-16, 3-20
 - trim filler 3-6, 3-12
 - trim kit 3-30
- active operating mode 5-8, B-2
- ASCII character sets C-1
- aux 1 connector 1-16
- aux 2 connector 1-16
- aux a-b connector 1-17
- auxiliary current 2-62
- auxiliary scanner
 - about 1-8
 - connectors 2-13
 - css 1-2, 1-3, 1-8, 2-2, 3-12, 5-5
 - device A-2, A-3
 - device settings 5-10
 - dual cable scale option 2-33
 - ports 1-10, 1-17, 2-2
 - RS-232 2-13, 3-20
 - RS-232 device port config 2-33
 - types 1-2
 - USB 2-8, 2-13

B

- bar codes
 - IBM RS-485
 - device type 2-52
 - port address none 17 2-57
 - port address none 5B 2-56
 - port address none 9B 2-55
 - IBM RS-488
 - port address 2-54
 - legal scale dampening filter 4-17
 - RS-232
 - device type 2-12
 - RS-232 device port configuration 2-33
 - scale display configuration 4-15
 - scale legal parameter 4-13, 4-14
 - scale pole display type 4-21
 - scale port address
 - none selected 2-58
 - port 6A 2-59
 - port 6B 2-60
 - port 6E 2-61
 - third party scale parameters 2-46, 2-48, 2-50
 - USB
 - device type 2-3, 2-4
- ## buttons
- camera activation 1-9, 1-16, 5-4
 - EAS 1-9, 1-15, 5-4
 - identifying firmware version 5-4
 - scale zero 1-9, 1-15, 5-3
 - soft reset 5-4
 - volume/tone 1-9, 1-15, 5-3

C

- calibration
 - electronic entry 4-3

Index - 2 MP7000 Scanner Scale Integrator Guide

- LED/beeper sequences 4-23
- manual 4-3
- parameter defaults 4-1
- parameters
 - legal scale dampening filter setting 4-17
 - scale display config 4-15
- calibration switch 1-16
- camera activation button 1-9, 1-16, 5-4
- character sets
 - ALT key C-6
 - ASCII C-1
 - extended key C-12
 - F key C-10
 - GUI key C-7
 - numeric key C-11
 - PF key C-9
- Checkpoint EAS . 1-16, 3-7, 3-18, 3-20, 3-23, 5-15, 5-16
- Checkpoint interlock connector 1-16
- cold start, power on requirement 4-2
- color camera
 - kit contents 6-1
 - kit parts 6-2
 - parts 6-3, 6-4, 6-5
- communication protocol
 - cable interface E-1
- components, installing 3-5
- configurations 1-3
- connecting
 - IBM RS-485 interface 2-52
 - RS-232 interface 2-12
 - USB interface 2-3
- connector ports 1-16
- connectors
 - 0.0 1-16
 - 12V DC 1-17
 - aux 1 1-16
 - aux 2 1-16
 - aux a-b 1-17
 - Checkpoint interlock 1-16
 - location on device 1-10
 - POS 1-17
 - RS-232 1-16
- counter cutout 3-13, 3-15, 3-17
- current, auxiliary 2-62
- customer side scanner 1-2, 1-3, 1-8, 2-2, 3-12, 5-5
- cutout, counter 3-13, 3-15, 3-17

D

- default parameters
 - user preferences 4-1
- diagram 1-9
- dimensions
 - counter cutouts 3-13, 3-15, 3-17

- front views 3-14, 3-16
- side views 3-14, 3-16, 3-18
- top views 3-13, 3-15, 3-17
- display, scale 1-12, 1-13, 1-16, 2-62, 3-8, 4-15, 5-5
- dual cable scale option 2-33

E

- EAS . . 1-16, 3-6, 3-7, 3-18, 3-20, 3-21, 3-23, 5-15, 5-16, 5-17
 - controllers 5-15
 - operating modes 5-16
- EAS button 1-9, 1-15, 5-4
- electrical power
 - AC/DC power cubes 3-3
 - considerations 3-3
 - grounding 3-3
 - POS equipment 3-3
- Electronic Article Surveillance 5-15
- error/warning codes
 - display notes A-2
 - general A-4
 - indicator LED A-2
 - scale A-6
 - troubleshooting A-3

F

- features
 - 7-segment display 1-15, 3-20, 4-2, 4-4, 4-5, 4-7, 4-8, 4-12, 5-2, 5-13, A-2, A-6
 - calibration switch 1-16
 - camera activation button 1-9, 1-16
 - color camera connection LED 1-9, 1-16
 - EAS button 1-9, 1-15
 - horizontal scan window 1-9
 - LED 1-9, 1-15
 - leveling screws 1-16
 - platter 1-9, 1-16, 5-6
 - scale 1-9, 1-16
 - scale display . 1-2, 1-12, 1-13, 1-16, 2-62, 3-8, 4-15, 5-5
 - scale zero button 1-9, 1-15
 - speaker 1-9
 - vertical scan window 1-9
 - volume/tone button 1-9, 1-15

H

- horizontal scan window 1-9
- host types
 - IBM RS-485 2-52
 - RS-232 2-12
 - USB 2-3, 2-4

I

IBM RS-485	
connection	2-52
parameters	2-53
identifying firmware version	5-4
input/output ports	2-62
install	
Checkpoint EAS antenna	3-23
components	3-5
customer side scanner	3-12
scale display	3-8
scanner/scale	3-12
Sensormatic coil	3-21
trim kit for the MP7X00	3-30

L

LED	1-9, 1-15, 5-1
LED display notes	A-2
leveling screws	1-16

M

maintenance	A-1
models	1-3

O

operating mode	5-8, B-2
operating modes	
idle operating mode	5-8, B-2

P

parts	1-9
platter	1-9, 1-16
install/remove	5-6
pole display	1-2, 1-16
ports, connector	1-10
POS connector	1-17
preparing the site	3-2
price computational scale interface	2-14
product configurations	1-3

Q

quick reference for installing components	3-5
quick reference, installing	3-5

R

RS-232	
aux 1 connector	1-16

aux 2 connector	1-16
connection	2-12
parameters	2-17

S

scale	1-9, 1-16
cable	A-3
legal scale dampening filter	4-17
scale display configuration	4-15
scale legal parameter	4-13, 4-14
scale pole display type	4-21
scale port address	
none selected	2-58
port 6A	2-59
port 6B	2-60
port 6E	2-61
scale display	1-2, 1-12, 1-13, 1-16, 2-62, 3-8, 4-15, 5-5
scale display, installing	3-8
scale zero button	1-9, 1-15, 5-3
scale, third party	2-46, 2-48, 2-50
scan window	1-9
scanning	5-14
Sensormatic	3-6, 3-7, 3-18, 3-20, 3-21, 5-15, 5-17
service information	3-2
setup	
connecting a USB interface	2-3
connecting an IBM RS-485 interface	2-52
connecting an RS-232 interface	2-12
connecting to an IBM RS-485 host	2-52
site preparation	3-2
soft reset button	5-4
speaker	1-9

T

third party scale parameters	2-46, 2-48, 2-50
tone button	1-9, 1-15
trim kit	3-30
troubleshooting	
7-segment display	A-2
assistance	A-3
error/warning codes	A-4
errors/warnings	A-2
LED display notes	A-2
scale warning codes	A-6
status indicator light	A-2

U

unpacking	3-6
USB	
connection	2-3
parameters	2-4

Index - 4 MP7000 Scanner Scale Integrator Guide

USB port 5-11
user preferences parameters 4-1

V

ventilation and spacing requirements 3-2
vertical scan window 1-9
volume/tone button 1-9, 1-15, 5-3



Zebra Technologies Corporation
3 Overlook Point
Lincolnshire, IL 60069, U.S.A.
www.zebra.com

ZEBRA and the stylized Zebra head are trademarks of Zebra Technologies Corporation, registered in many jurisdictions worldwide. All other trademarks are the property of their respective owners. ©2023 Zebra Technologies Corporation and/or its affiliates. All rights reserved.