

Ricambi Spare parts Pièces de rechange Austauschteile Repuestos Peças para troca

0084303500 Gulliver R14

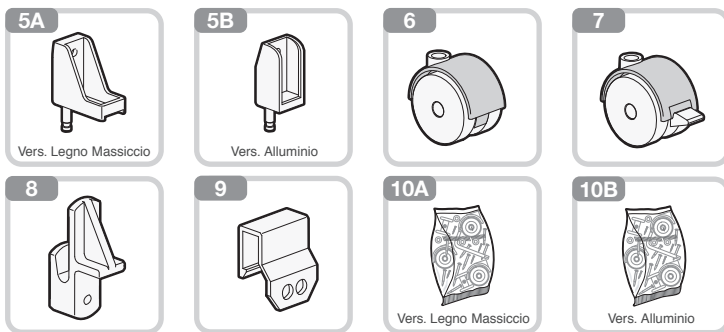
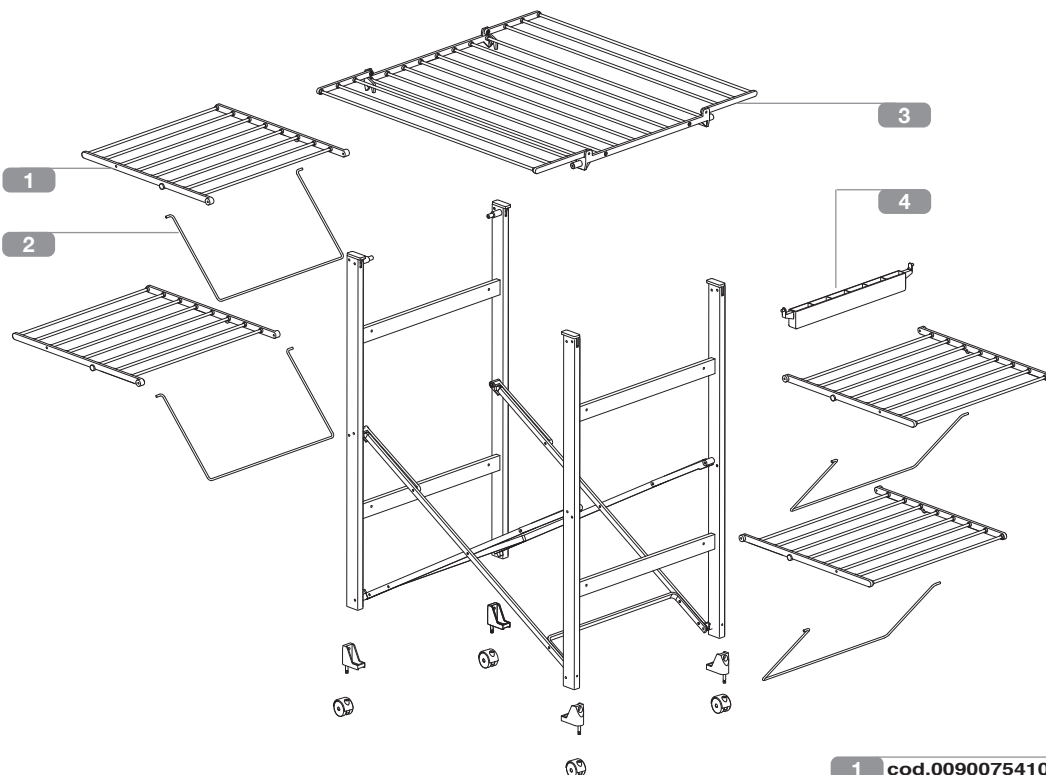

- 1** cod.0090075410
- 2** cod.7030415880
- 3** cod.0090075310
- 4** cod.0047270110
- 5A** cod.0040102519
- 5B** cod.0040101119
- 6** cod.0049220219
- 7** cod.0049220419
- 8** cod.0040003110
- 9** cod.0047270210
- 10A** cod.0090126119
- 10B** cod.0090075219

I Ogni codice ricambio deve essere sempre composto da dieci cifre: completare gli eventuali codici da otto cifre con le due indicanti il colore. **Attenzione:** le sostituzioni devono essere richieste solamente tramite il rivenditore. Le caratteristiche cromatiche dei vari materiali possono differire tra loro e non sono vincolanti per il produttore.

GB Every code reciprocation always must be composed from ten figures: to complete the eventual codes from eight indicating figures with the two color. **Note:** the replacement parts may only be ordered through the retailer. The colour characteristics of the various materials can differ and are not binding for the manufacturer.

F Chaque code je rends doit être toujours composé de dix chiffres : compléter les éventuels codes de huit chiffres avec deux heures indiquant la couleur. **Attention:** les substitutions ne peuvent être effectuées que par l'intermédiaire du revendeur. Les caractéristiques chromatiques des différents matériaux peuvent varier et n'ont pas de caractère obligatoire pour le fabricant.

D Jeder Code gebe ich zurück muß mich immer aus zehn Zahlen zusammensetzen: die möglichen Codes von acht Zahlen mit zwei Stunden zu vervollständigen, die die Farbe angeben. **Wichtig:** ersatz darf nur über den Händler angefordert werden. Die farblichen Merkmale der einzelnen Materialien können voneinander abweichen und sind für den Hersteller nicht verbindlich.

E Cada código vuelvo debo siempre ser compuesto de diez cifras: completar los posibles códigos de ocho cifras con las dos horas que indican el color. **Atención!** las sustituciones deben ser solicitadas solamente a través del revendedor. Las características cromáticas de los diversos materiales pueden diferir entre sí y no son vinculantes para el productor.

BRA Cada código de troca deve ter 10 números: completar eventuais códigos de 08 números com os dois números da cor. **Atenção:** as substituições tem que serem requeridas somente através do revendedor. As características cromadas dos vários materiais podem diferenciar entre elas e não está vinculado ao produtor.

Alluminio bianco	00
Legno noce	12
Alluminio pink	38
Alluminio green	41
Alluminio arancio	54
Alluminio silver	63
Canaletto	76
Wengé	86
Bianco/rosso	90

FOPPAPEDRETTI
Foppa Pedretti S.p.A. Via A. Volta, 11
24064 - Grumello del Monte, Bergamo - Italy
tel +39 035.830.497 fax +39 035.831.283
www.foppapedretti.it



FOPPAPEDRETTI[®]

Istruzioni di montaggio e uso
Instructions for assembly and use
Instructions de montage et mode d'emploi

Montage- und Gebrauchsanweisung
Instrucciones de montaje y uso
Instruções de Montagem e Uso

Stendibiancheria chiudibile
Folding clothes airer
Sèche linge pliant
Zusammenklappbarer Wäscheständer
Cuelga lencería plegable
Varal extensível

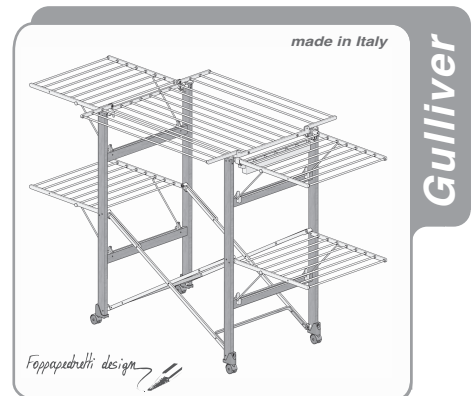

Avvertenze Warning Avertissement Warnung Advertencias Advertências

I Leggere attentamente e conservare per future referenze

- Controllate periodicamente il perfetto bloccaggio di tutti i componenti.
- Verificate la perfetta apertura di **Gulliver** prima di appendervi la biancheria.
- Per evitare rischi di ribaltamento non stendere la biancheria sui telai laterali quando **Gulliver** è chiuso (fig. A).
- Pulire con un panno umido o del detergente neutro (**no solventi**) e asciugare accuratamente.
- Non esporre alle intemperie.

D Aufmerksam lesen und für zukünftige Referenzen aufbewahren

- Regelmäßig die perfekte Befestigung aller Komponenten kontrollieren.
- Die perfekte Öffnung von **Gulliver** überprüfen, bevor Wäsche darauf aufgehängt wird.
- Um die Umkippgefahr zu vermeiden, keine Wäsche auf die seitlichen Rahmen hängen, wenn **Gulliver** geschlossen ist (fig. A).
- Mit einem feuchtem Tuch oder neutralem Reinigungsmittel (**keine Lösungsmittel**) reinigen und gut abtrocknen.
- Keinen Witterungseinflüssen aussetzen.

GB Read the instructions carefully and keep for future reference

- Every so often check that all the components are perfectly secure.
- Check that **Gulliver** has been opened out correctly before hanging washing on it.
- To prevent **Gulliver** from tipping over, do not hang washing on the side frames when it is folder (fig. A).
- Clean with a damp cloth or with neutral detergent (**not solvents**) and dry carefully.
- Do not leave out in bad weather.

E Leer atentamente y conservar para futuras referencias

- Controlar periódicamente el bloqueo perfecto de todos los componentes.
- Verificar la perfecta apertura de **Gulliver** antes de colgar la ropa.
- Para evitar riesgos de vuelco no colgar la ropa sobre los bastidores laterales cuando **Gulliver** está cerrado (fig. A).
- Limpiar con un paño húmedo o con detergente neutro (**no con solventes**) y secar cuidadosamente.
- No exponer a la intemperie.

F Lire attentivement et conserver en cas de besoin

- Contrôler périodiquement le parfait blocage de tous les composants.
- Vérifiez la bonne ouverture de **Gulliver** avant d'étendre le linge.
- Pour éviter au séchoir de se renverser n'étendez jamais le linge sur les châssis latéraux quand **Gulliver** est fermé (fig. A).
- Nettoyez à l'aide d'un chiffon humide ou de détergent neutre (**non-solvants**) puis essuyez-le soigneusement.
- Ne pas exposer aux intempéries.

BRA Ler atentamente e guardar para futuras referências.

- Verificar periodicamente a perfeita blocagem de todos os componentes.
- Verificar a perfeita abertura de **Gulliver** antes de pendurar a roupa.
- Para evitar riscos de tombamento não pendurar a roupa nas laterais quando **Gulliver** é fechado (Fig. A).
- Não expor ao tempo.
- Limpar com um pano úmido ou detergente neutro (**não solvente**) e secar com cuidado.

Montaggio Assembly Assemblage Montage Montaje Montagem

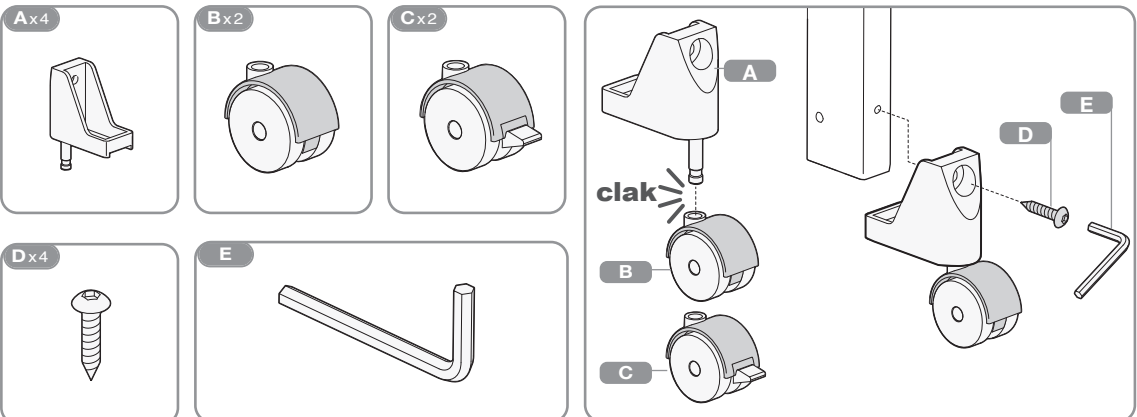

open

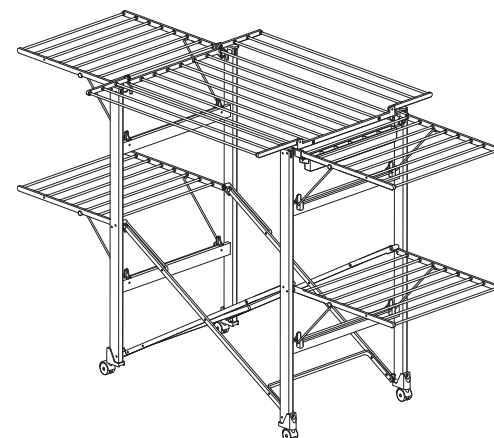
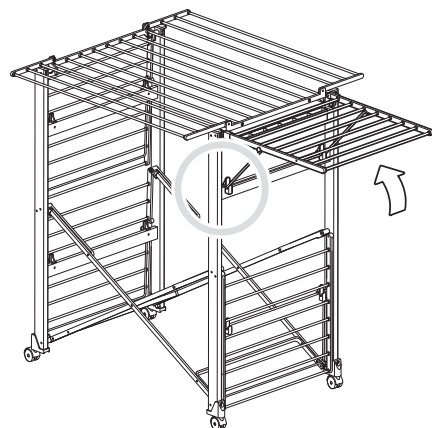
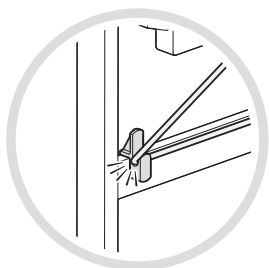
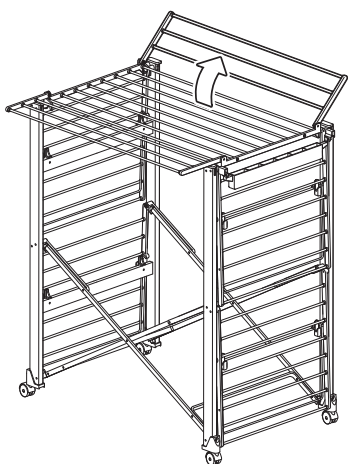
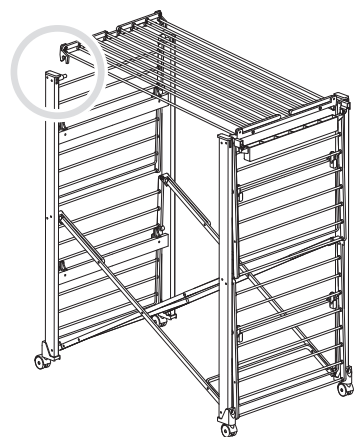
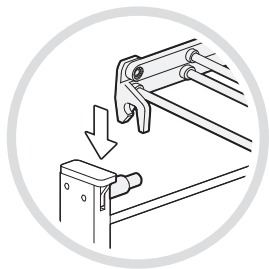
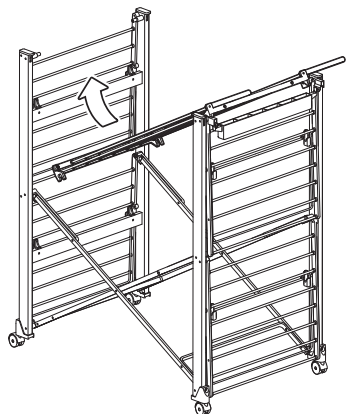
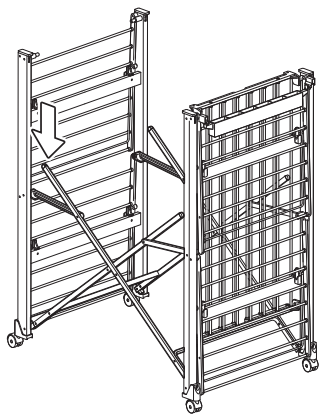
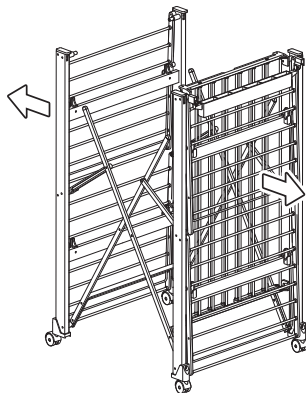
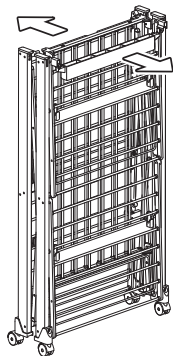
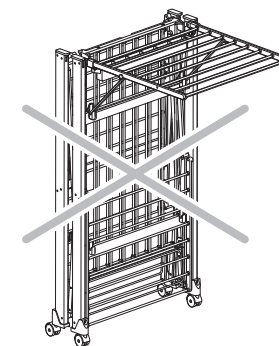
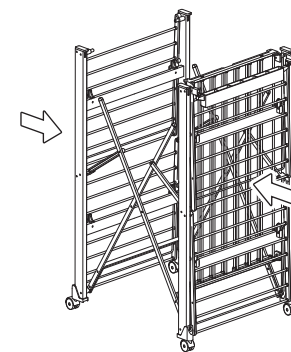
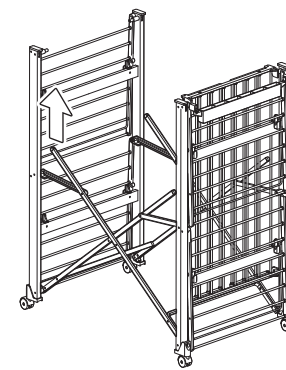
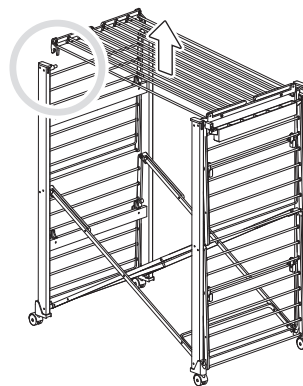

Fig. A



closed



Composizione Composition Composition Materialien Composizione Composição

- | | |
|---|---|
| <p>I • Telaio di sostegno in legno di faggio per la versione legno.
 • Telaio di sostegno in alluminio per le versioni alluminio.
 • Bacchette stendibiancheria in alluminio verniciato.
 • Tiranti di apertura/chiusura in alluminio verniciato.
 • Supporti portabacchette in materiale plastico.
 • Ruote in nylon.
 • Vaschetta portamollette <i>Clothy</i> in materiale plastico.</p> | <p>D • Stützrahmen aus Buchenholz für die Version aus Holz.
 • Stützrahmen aus lackiertem Aluminium für die Version aus Aluminium.
 • Stäbe des Wäscheständers aus lackiertem Aluminium.
 • Öffnungs-Schließungsspannstangen aus lackiertem Aluminium.
 • Stangenhalterungen aus Plastikmaterial.
 • Rollen aus Nylonelemente.
 • Klammernhalterwännchen <i>Clothy</i> aus Plastikmaterial.</p> |
| <p>GB • Beechwood supporting frame for the wooden version.
 • Coated aluminium supporting frame for the aluminium versions.
 • Coated aluminium airing rails.
 • Coated aluminium opening/closing rods.
 • Plastic rail supports.
 • Nylon castors.
 • Plastic tray for <i>Clothy</i> clothes-pegs.</p> | <p>E • Bastidor de sostén de aluminio pintado para la versión en aluminio.
 • Bastidor de sostén de madera de haya para la versión en madera.
 • Varillas del tender de aluminio pintado.
 • Tirantes de apertura/cerrado de aluminio pintado.
 • Soportes porta varillas de material plástico.
 • Ruedas de nylon.
 • Cubeta porta broches <i>Clothy</i> de material plástico.</p> |
| <p>F • Châssis support en bois de hêtre pour la version bois.
 • Châssis support en aluminium pour la version aluminium.
 • Tringles en aluminium vernis.
 • Tirants ouverture/fermeture en aluminium vernis.
 • Supports porte-tringles en matière plastique.
 • Roulettes en nylon.
 • Bac porte pincés <i>Clothy</i> en matière plastique.</p> | <p>BRA • Estrutura em madeira de faia pintada para a versão madeira.
 • Estrutura em alumínio para a versão em alumínio.
 • Moldura / Quadro varal em polipropileno carregado.
 • Pauxinhos varal em alumínio pintado.
 • Puxadores de abertura e fechamento em alumínio pintado.
 • Suporte pauxinhos em material plástico.
 • Rodas em nylon.
 • Porta prendedores <i>Clothy</i> em material plástico.</p> |