

AIR CONDITIONER

Wall mounted type

DESIGN & TECHNICAL MANUAL

INDOOR



ASYG07KPCA
ASYG09KPCA
ASYG12KPCA

OUTDOOR



AOYG07KPCA
AOYG09KPCA
AOYG12KPCA

FUJITSU GENERAL LIMITED

Notices:

- Product specifications and design are subject to change without notice for future improvement.
- For further details, please check with our authorized dealer.

CONTENTS

Part 1. INDOOR UNIT	1
1. Specifications	2
2. Dimensions	4
2-1. Models: ASYG07KPCA, ASYG09KPCA, and ASYG12KPCA	4
3. Wiring diagrams	6
3-1. Models: ASYG07KPCA, ASYG09KPCA, and ASYG12KPCA	6
4. Capacity table	7
4-1. Cooling capacity.....	7
4-2. Heating capacity	8
5. Fan performance	9
5-1. Air velocity distributions.....	9
5-2. Airflow	11
6. Operation noise (sound pressure)	13
6-1. Noise level curve.....	13
6-2. Sound level check point	14
7. Safety devices	15
8. Remote controller	16
8-1. Wireless remote controller	16
9. Function settings	18
9-1. Function settings by using remote controller.....	18
9-2. Custom code setting for wireless remote controller.....	22
10. Accessories	23
11. Optional parts	24
11-1.Others.....	24

CONTENTS (continued)

Part 2. OUTDOOR UNIT	25
1. Specifications	26
2. Dimensions	27
2-1. Models: AOYG07KPCA, AOYG09KPCA, and AOYG12KPCA	27
3. Installation space	28
3-1. Models: AOYG07KPCA, AOYG09KPCA, and AOYG12KPCA	28
4. Refrigerant circuit	31
4-1. Models: AOYG07KPCA, AOYG09KPCA, and AOYG12KPCA	31
5. Wiring diagrams	32
5-1. Models: AOYG07KPCA, AOYG09KPCA, and AOYG12KPCA	32
6. Capacity compensation rate for pipe length and height difference	33
6-1. Models: AOYG07KPCA and AOYG09KPCA	33
6-2. Model: AOYG12KPCA	34
7. Additional charge calculation	35
7-1. Models: AOYG07KPCA and AOYG09KPCA	35
7-2. Model: AOYG12KPCA	35
8. Airflow	36
8-1. Model: AOYG07KPCA	36
8-2. Model: AOYG09KPCA	36
8-3. Model: AOYG12KPCA	37
9. Operation noise (sound pressure)	38
9-1. Noise level curve.....	38
9-2. Sound level check point	39
10. Electrical characteristics	40
11. Safety devices	41
12. Accessories	42
12-1. Models: AOYG07KPCA, AOYG09KPCA, and AOYG12KPCA	42

Part 1. INDOOR UNIT

WALL MOUNTED TYPE:

ASYG07KPCA

ASYG09KPCA

ASYG12KPCA

1. Specifications

Type				Wall mounted					
				Inverter heat pump					
Model name				ASYG07KPCA	ASYG09KPCA	ASYG12KPCA			
Power supply				230 V ~ 50 Hz					
Power supply intake				Outdoor unit					
Available voltage range				198—264 V					
Capacity	Cooling	Rated	kW	2.00	2.50	3.40			
			Btu/h	6,800	8,500	11,600			
		Min.—Max.	kW	0.9—2.8	0.9—3.0	0.9—3.7			
	Heating	Rated	Btu/h	3,100—9,600	3,100—10,200	3,100—12,600			
			kW	2.50	2.80	3.80			
		Min.—Max.	Btu/h	8,500	9,500	13,000			
Input power	Cooling	Rated	kW	0.48	0.71	1.00			
			Min.—Max.	kW	0.25—1.03	0.25—1.05	0.25—1.14		
		Heating	Rated	kW	0.63	0.79	1.14		
	Min.—Max.		kW	0.25—1.39	0.25—1.39	0.25—1.60			
	Fan	HIGH	MED	LOW	QUIET	W	21.5	26.9	
							12.5	14.5	
							6.3	7.1	
							3.0	3.0	
	Current	Cooling	Rated	A	2.7	3.5	4.7		
					3.2	3.8	5.6		
	EER	Cooling	kW/kW	4.17	3.52	3.40			
				3.97	3.54	3.33			
COP	Heating	kW/kW	1.9	2.1	2.6				
			77	87	92				
Sensible capacity	Cooling	kW	85	90	89				
			77	87	92				
Power factor	Cooling	%	85	90	89				
			77	87	92				
Moisture removal	Cooling	L/h (pints/h)	1.0 (1.8)	1.3 (2.30)	1.8 (3.20)				
			77	87	92				
Maximum operating current *1	Cooling	A	6.5	6.5	6.5				
			9.0	9.0	9.0				
Fan	Cooling	HIGH	MED	LOW	QUIET	m ³ /h	580	580	630
							460	460	490
							340	340	360
							240	240	240
							580	580	630
							460	460	490
	380	380	380						
	Heating	HIGH	MED	LOW	QUIET	m ³ /h	260	260	260
							260	260	260
							260	260	260
							260	260	260
							260	260	260
260							260	260	
Type × Q'ty	Cross flow fan × 1								
	Motor output								
Sound pressure level *2	Cooling	HIGH	MED	LOW	QUIET	dB (A)	27	27	27
							45	45	46
							38	38	40
							31	31	33
	Heating	HIGH	MED	LOW	QUIET	dB (A)	22	22	22
							45	45	46
							40	40	40
							36	36	35
	Heating	HIGH	MED	LOW	QUIET	dB (A)	26	26	27
							26	26	27
							26	26	27
							26	26	27
Heat exchanger type	Dimensions (H × W × D)			mm	210 × 600 × 26.6				
	Fin pitch				1.3				
	Rows × Stages				2 × 10				
	Pipe type				Copper tube				
	Fin type				Aluminum				
Enclosure	Material			Polystyrene					
	Color			White					
Dimensions (H × W × D)	Net			Approximate color of Munsell N 9.25/					
	Gross			270 × 784 × 224					
Weight	Net			279 × 864 × 334					
	Gross			8.0					
Connection pipe	Size	Liquid	Gas	mm (in)	11.0				
					Ø 6.35 (1/4)				
Drain hose	Method			Flare					
	Material			PP+HDPE					
Operation range	Size			mm					
	°C			Ø 11.8 (I.D.), Ø 15 to Ø 16.8 (O.D.)					
Remote controller type	Cooling			°C					
	Heating			°C					
				18 to 32					
				80 or less					
				16 to 30					
				Wireless					

NOTES:

- Specifications are based on the following conditions:
 - Cooling: Indoor temperature of 27 °CDB/19 °CWB, and outdoor temperature of 35 °CDB/24 °CWB.
 - Heating: Indoor temperature of 20 °CDB/15 °CWB, and outdoor temperature of 7 °CDB/6 °CWB.
 - Pipe length: 5 m, Height difference: 0 m. (Between outdoor unit and indoor unit.)
- Protective function might work when using it outside the operation range.
- *1: Maximum current is maximum value when operated within the operation range.
- *2: Sound pressure level:
 - Measured values in manufacturer's anechoic chamber.
 - Because of the surrounding sound environment, the sound levels measured in actual installation conditions might be higher than the specified values here.

Specifications for Lot10					
Model name		ASYG07KPCA		ASYG09KPCA	ASYG12KPCA
Energy efficiency class	Cooling	A ⁺⁺			
	Heating (Average)	A ⁺			
P design	Cooling	kW	2.0 (35 °C)	2.5 (35 °C)	3.4 (35 °C)
	Heating (Average)		2.2 (-10 °C)	2.4 (-10 °C)	2.5 (-10 °C)
SEER	Cooling	kWh/kWh	6.7	6.7	6.3
SCOP	Heating (Average)		4.0	4.0	4.1
Annual energy consumption	QCE	kWh/a	104	131	189
	QHE (Average)		769	840	853
Sound power level	Cooling	HIGH	dB (A)	57	58
	Heating			58	58

2. Dimensions

2-1. Models: ASYG07KPCA, ASYG09KPCA, and ASYG12KPCA

Unit: mm

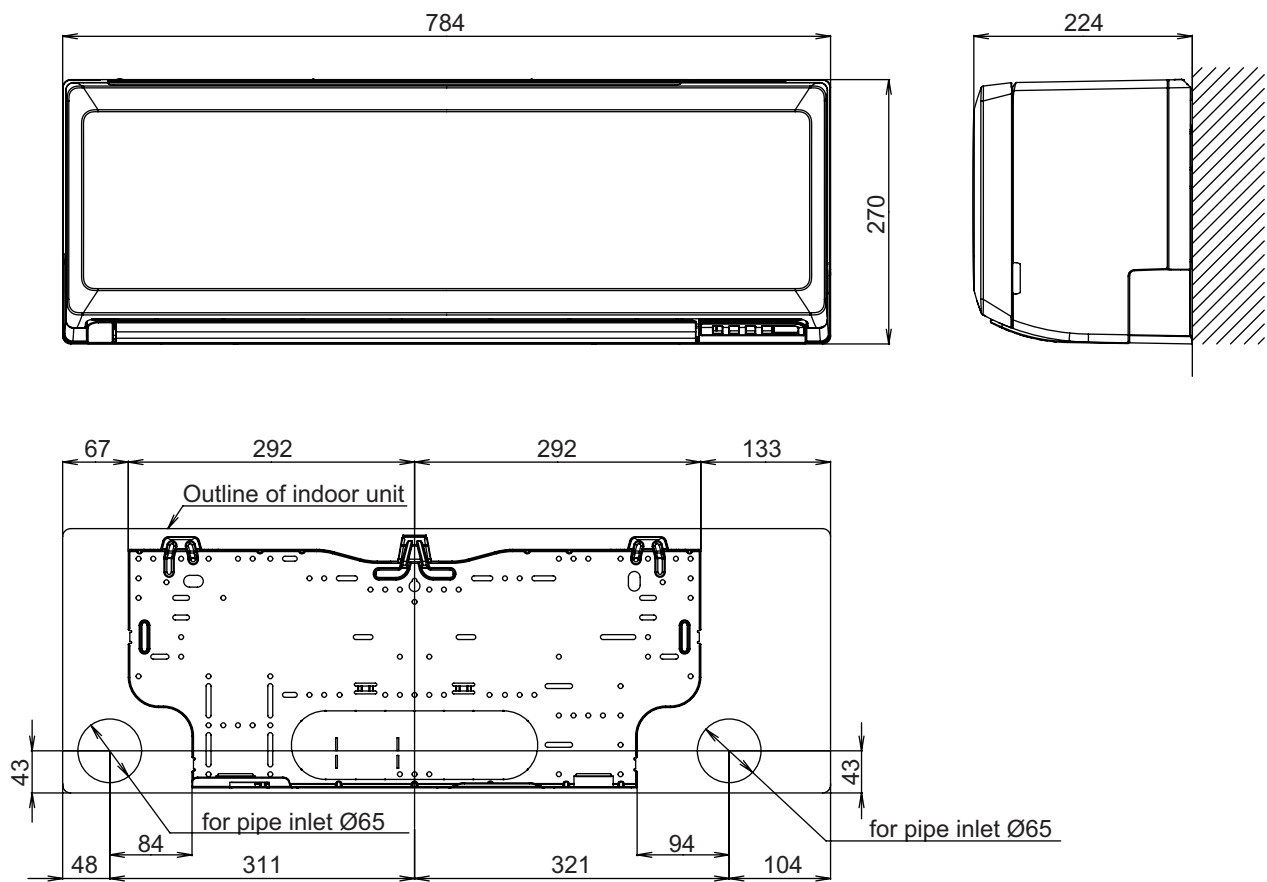

■ Installation space requirement

Provide sufficient installation space for product safety.

Unit: mm

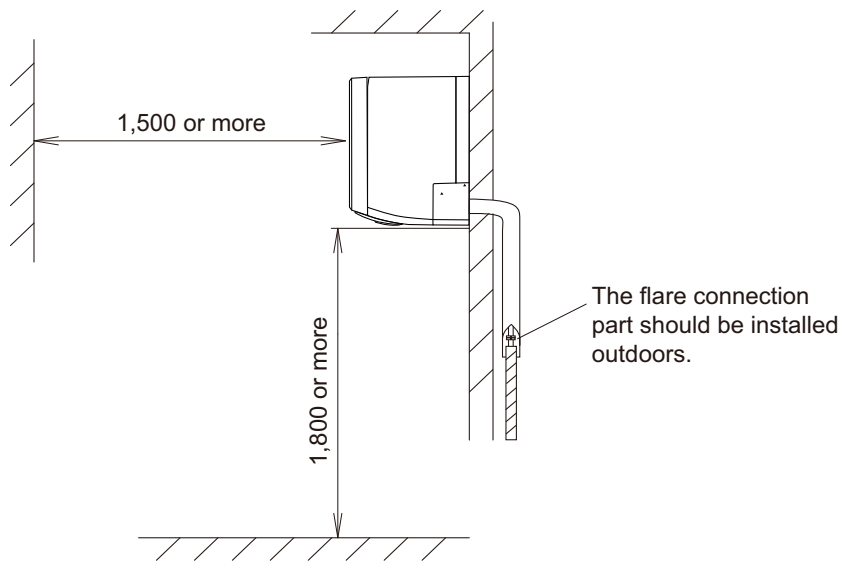
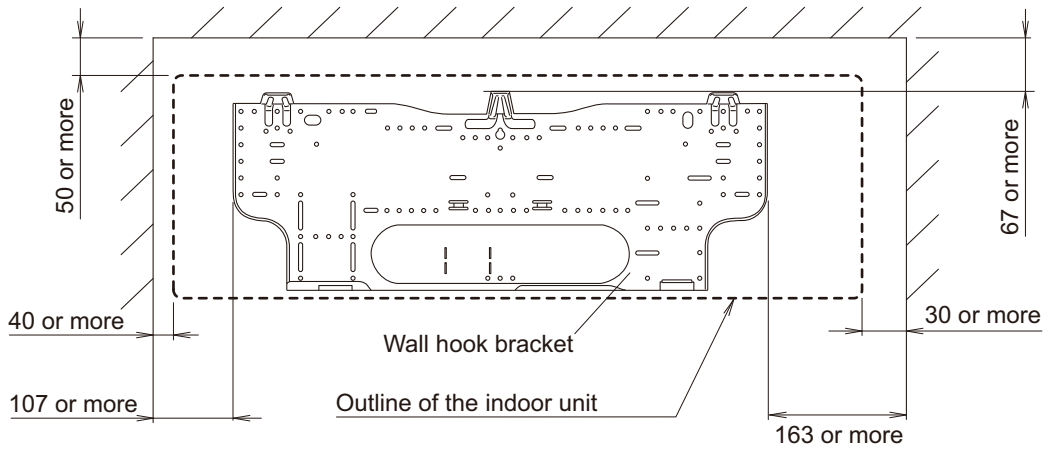

3. Wiring diagrams

3-1. Models: ASYG07KPCA, ASYG09KPCA, and ASYG12KPCA

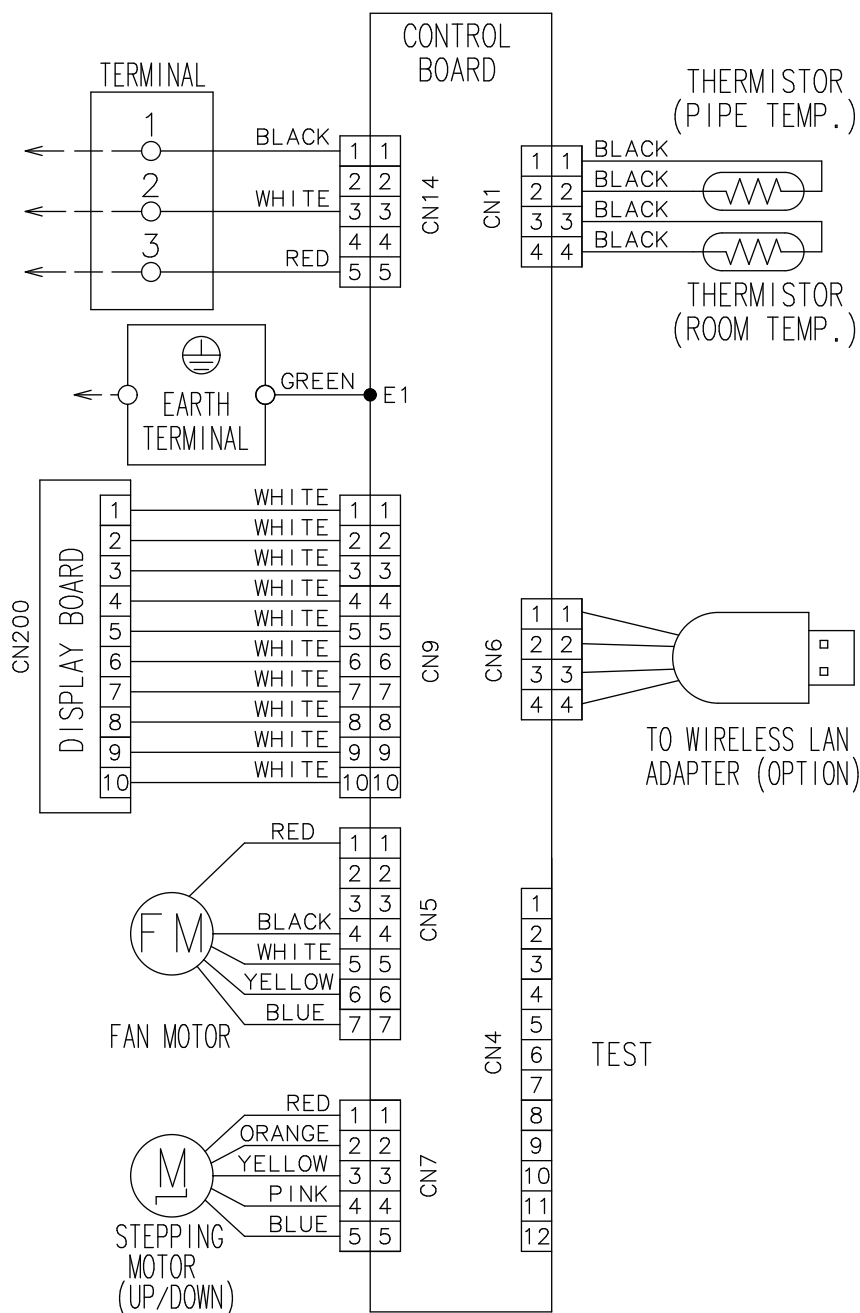

4. Capacity table

Capacity tables show each of following values calculated based on the outdoor temperature and the indoor temperature, under given Airflow Rate (AFR):

For cooling capacity: Total Capacity (TC), Sensible Heat Capacity (SHC), and Input Power (IP)

For heating capacity: Total Capacity (TC) and Input Power (IP)

4-1. Cooling capacity

■ Model: ASYG07KPCA

AFR		m ³ /h									580													
Outdoor temperature	Indoor temperature																							
	°CDB			18			21			23			25			27			29			32		
	°CWB			12			15			16			18			19			21			23		
	°CDB			TC	SHC	IP	TC	SHC	IP	TC	SHC	IP	TC	SHC	IP	TC	SHC	IP	TC	SHC	IP	TC	SHC	IP
	kW			kW			kW			kW			kW			kW			kW			kW		
-10	1.49	1.03	0.22	1.65	1.04	0.23	1.71	1.13	0.23	1.82	1.13	0.23	1.88	1.22	0.23	1.99	1.22	0.23	2.11	1.30	0.23	2.11	1.30	0.23
0	1.56	1.09	0.28	1.74	1.09	0.28	1.80	1.19	0.29	1.92	1.19	0.29	1.98	1.29	0.29	2.10	1.28	0.29	2.22	1.37	0.30	2.22	1.37	0.30
5	1.57	1.09	0.28	1.75	1.10	0.28	1.81	1.19	0.28	1.93	1.20	0.28	1.99	1.29	0.29	2.11	1.29	0.29	2.23	1.37	0.29	2.23	1.37	0.29
10	1.58	1.10	0.27	1.76	1.10	0.27	1.82	1.20	0.28	1.94	1.20	0.28	2.00	1.30	0.28	2.12	1.29	0.28	2.24	1.38	0.29	2.24	1.38	0.29
15	1.73	1.22	0.30	1.92	1.22	0.31	1.99	1.33	0.31	2.12	1.34	0.31	2.18	1.44	0.31	2.32	1.44	0.32	2.45	1.53	0.32	2.45	1.53	0.32
20	1.87	1.32	0.34	2.09	1.33	0.34	2.16	1.45	0.34	2.30	1.45	0.35	2.37	1.57	0.35	2.51	1.56	0.35	2.65	1.66	0.36	2.65	1.66	0.36
25	1.78	1.26	0.38	1.98	1.26	0.38	2.05	1.37	0.39	2.18	1.38	0.39	2.25	1.49	0.39	2.39	1.48	0.40	2.52	1.58	0.40	2.52	1.58	0.40
30	1.68	1.19	0.42	1.87	1.19	0.43	1.94	1.30	0.43	2.06	1.30	0.43	2.13	1.41	0.44	2.25	1.40	0.44	2.38	1.49	0.44	2.38	1.49	0.44
35	1.58	1.12	0.46	1.76	1.12	0.47	1.82	1.22	0.47	1.94	1.23	0.48	2.00	1.32	0.48	2.12	1.32	0.48	2.24	1.40	0.49	2.24	1.40	0.49
40	1.52	1.00	0.46	1.70	1.00	0.47	1.75	1.09	0.47	1.87	1.09	0.48	1.93	1.18	0.48	2.04	1.17	0.48	2.16	1.25	0.49	2.16	1.25	0.49
46	1.47	0.92	0.46	1.64	0.93	0.47	1.69	1.01	0.47	1.80	1.01	0.48	1.86	1.09	0.48	1.97	1.09	0.48	2.08	1.16	0.49	2.08	1.16	0.49

■ Model: ASYG09KPCA

AFR		m ³ /h									580													
Outdoor temperature	Indoor temperature																							
	°CDB			18			21			23			25			27			29			32		
	°CWB			12			15			16			18			19			21			23		
	°CDB			TC	SHC	IP	TC	SHC	IP	TC	SHC	IP	TC	SHC	IP	TC	SHC	IP	TC	SHC	IP	TC	SHC	IP
	kW			kW			kW			kW			kW			kW			kW			kW		
-10	1.82	1.25	0.25	2.03	1.26	0.25	2.10	1.36	0.25	2.24	1.37	0.26	2.31	1.48	0.26	2.45	1.47	0.26	2.59	1.57	0.26	2.59	1.57	0.26
0	1.91	1.31	0.34	2.13	1.31	0.35	2.20	1.43	0.35	2.35	1.43	0.35	2.42	1.55	0.36	2.57	1.54	0.36	2.71	1.64	0.36	2.71	1.64	0.36
5	1.88	1.28	0.33	2.09	1.29	0.33	2.16	1.40	0.33	2.30	1.41	0.34	2.38	1.52	0.34	2.52	1.51	0.34	2.66	1.61	0.34	2.66	1.61	0.34
10	1.84	1.26	0.31	2.05	1.27	0.31	2.12	1.38	0.32	2.26	1.38	0.32	2.33	1.49	0.32	2.47	1.49	0.32	2.61	1.58	0.33	2.61	1.58	0.33
15	2.09	1.21	0.40	2.33	1.21	0.41	2.41	1.32	0.41	2.57	1.32	0.42	2.65	1.43	0.42	2.80	1.43	0.42	2.96	1.52	0.43	2.96	1.52	0.43
20	2.34	1.63	0.50	2.61	1.63	0.51	2.70	1.78	0.51	2.87	1.78	0.51	2.96	1.93	0.52	3.14	1.92	0.52	3.32	2.04	0.53	3.32	2.04	0.53
25	2.22	1.54	0.56	2.48	1.55	0.57	2.56	1.69	0.57	2.73	1.69	0.58	2.81	1.83	0.58	2.98	1.82	0.59	3.15	1.94	0.59	3.15	1.94	0.59
30	2.10	1.45	0.62	2.34	1.46	0.63	2.42	1.59	0.63	2.58	1.60	0.64	2.66	1.72	0.64	2.82	1.72	0.65	2.98	1.83	0.66	2.98	1.83	0.66
35	1.98	1.37	0.69	2.20	1.38	0.70	2.28	1.50	0.70	2.43	1.50	0.71	2.50	1.62	0.71	2.65	1.61	0.72	2.80	1.72	0.72	2.80	1.72	0.72
40	1.90	1.22	0.68	2.12	1.23	0.70	2.19	1.33	0.70	2.34	1.34	0.71	2.41	1.44	0.71	2.55	1.44	0.72	2.70	1.53	0.72	2.70	1.53	0.72
46	1.84	1.13	0.68	2.04	1.14	0.69	2.11	1.24	0.70	2.25	1.24	0.70	2.32	1.34	0.71	2.46	1.33	0.71	2.60	1.42	0.72	2.60	1.42	0.72

■ Model: ASYG12KPCA

AFR		m ³ /h									630													
Outdoor temperature	Indoor temperature																							
	°CDB			18			21			23			25			27			29			32		
	°CWB			12			15			16			18			19			21			23		
	°CDB			TC	SHC	IP	TC	SHC	IP	TC	SHC	IP	TC	SHC	IP	TC	SHC	IP	TC	SHC	IP	TC	SHC	IP
	kW			kW			kW			kW			kW			kW			kW			kW		
-10	2.65	1.79	0.41	2.96	1.80	0.41	3.06	1.95	0.41	3.26	1.96	0.42	3.36	2.12	0.42	3.56	2.11	0.43	3.76	2.25	0.43	3.76	2.25	0.43
0	2.57	1.73	0.43	2.87	1.74	0.44	2.97	1.89	0.44	3.16	1.90	0.44	3.26	2.05	0.45	3.45	2.04	0.45	3.65	2.18	0.46	3.65	2.18	0.46
5	2.54	1.71	0.48	2.83	1.72	0.49	2.93	1.87	0.49	3.12	1.88	0.50	3.21	2.03	0.50	3.41	2.02	0.50	3.60	2.15	0.51	3.60	2.15	0.51
10	2.50	1.69	0.53	2.79	1.70	0.54	2.88	1.84	0.54	3.07	1.85	0.55	3.17	2.00	0.55	3.36	1.99	0.56	3.55	2.12	0.56	3.55	2.12	0.56
15	2.84	1.63	0.62	3.17	1.64	0.63	3.28	1.78	0.63	3.49	1.78	0.64	3.60	1.93	0.64	3.82	1.92	0.65	4.03	2.04	0.65	4.03	2.04	0.65
20	3.18	2.18	0.70	3.55	2.19	0.71	3.67	2.39	0.72	3.91	2.39	0.72	4.03	2.59	0.73	4.27	2.57	0.73	4.51	2.74	0.74	4.51	2.74	0.74
25	3.02	2.07	0.79	3.37	2.08	0.80	3.48	2.27	0.81	3.71	2.27	0.81	3.83	2.45	0.82	4.06	2.44	0.83	4.28	2.60	0.83	4.28	2.60	0.83
30	2.86	1.96	0.88	3.18	1.97	0.89	3.29	2.14	0.89	3.51	2.15	0.90	3.62	2.32	0.91	3.83	2.31	0.92	4.05	2.46	0.93	4.05	2.46	0.93
35	2.69	1.84	0.97	2.99	1.85	0.98	3.09	2.01	0.99	3.30	2.02	1.00	3.40	2.18	1.00	3.60	2.17	1.01	3.81	2.31	1.02	3.81	2.31	1.02
40	2.39	1.64	0.96	2.67	1.65	0.98	2.76	1.79	0.98	2.94	1.80	0.99	3.03	1.94	1.00	3.21	1.94	1.01	3.39	2.06	1.02	3.39	2.06	1.02
46	2.22	1.52	0.96	2.47	1.53	0.98	2.56	1.66	0.98	2.73	1.67	0.99	2.81	1.80	1.00	2.98	1.80	1.01	3.15	1.91	1.02	3.15	1.91	1.02

4-2. Heating capacity

NOTE: Values mentioned in the table are calculated based on the maximum capacity.

Model: ASYG07KPCA

AFR	m ³ /h	580
-----	-------------------	-----

			Indoor temperature																																																																																																			
			16			18			20			22			24																																																																																							
			TC	IP	kW	TC	IP	kW	TC	IP	kW	TC	IP	kW	TC	IP	kW																																																																																					
Outdoor temperature	°CDB	°CWB	1.84	0.88	1.83	0.90	1.79	0.92	1.75	0.94	1.70	0.96	2.14	0.93	2.09	0.95	2.04	0.97	1.98	0.99	1.93	1.01	2.47	1.01	2.41	1.03	2.36	1.06	2.30	1.08	2.24	1.10	2.93	1.15	2.86	1.17	2.79	1.20	2.72	1.22	2.65	1.24	3.31	1.28	3.31	1.31	3.23	1.33	3.15	1.36	3.06	1.39	3.47	1.33	3.44	1.36	3.40	1.39	3.32	1.42	3.23	1.45	3.74	1.38	3.65	1.41	3.56	1.44	3.47	1.47	3.38	1.50	3.81	1.39	3.72	1.42	3.63	1.45	3.54	1.48	3.45	1.51	3.68	1.09	3.59	1.12	3.50	1.14	3.41	1.16	3.33	1.18	3.89	1.09	3.79	1.12	3.70	1.14	3.61	1.16	3.52	1.18

Model: ASYG09KPCA

AFR	m ³ /h	580
-----	-------------------	-----

			Indoor temperature																																																																																																			
			16			18			20			22			24																																																																																							
			TC	IP	kW	TC	IP	kW	TC	IP	kW	TC	IP	kW	TC	IP	kW																																																																																					
Outdoor temperature	°CDB	°CWB	2.12	0.88	2.12	0.90	2.09	0.92	2.10	0.94	2.08	0.96	2.53	0.89	2.47	0.91	2.41	0.93	2.34	0.95	2.28	0.96	2.85	0.96	2.78	0.98	2.71	1.00	2.65	1.02	2.58	1.04	3.33	1.11	3.25	1.14	3.17	1.16	3.09	1.18	3.01	1.21	3.80	1.27	3.71	1.30	3.62	1.32	3.53	1.35	3.44	1.38	3.99	1.33	3.90	1.36	3.80	1.39	3.71	1.42	3.61	1.45	4.13	1.38	4.03	1.41	3.94	1.44	3.84	1.47	3.74	1.50	4.16	1.39	4.06	1.42	3.96	1.45	3.86	1.48	3.77	1.51	3.99	1.09	3.90	1.12	3.80	1.14	3.71	1.16	3.61	1.18	4.10	1.09	4.00	1.12	3.90	1.14	3.80	1.16	3.71	1.18

Model: ASYG12KPCA

AFR	m ³ /h	630
-----	-------------------	-----

			Indoor temperature																																																																																																			
			16			18			20			22			24																																																																																							
			TC	IP	kW	TC	IP	kW	TC	IP	kW	TC	IP	kW	TC	IP	kW																																																																																					
Outdoor temperature	°CDB	°CWB	2.73	1.03	2.67	1.05	2.60	1.07	2.54	1.10	2.47	1.12	2.91	1.08	2.85	1.10	2.78	1.12	2.71	1.14	2.64	1.17	3.31	1.17	3.23	1.19	3.15	1.21	3.08	1.24	3.00	1.26	4.03	1.32	3.94	1.35	3.84	1.38	3.74	1.40	3.65	1.43	4.75	1.47	4.64	1.51	4.53	1.54	4.41	1.57	4.30	1.60	5.04	1.54	4.92	1.57	4.80	1.60	4.68	1.63	4.56	1.66	4.61	1.38	4.50	1.41	4.39	1.44	4.28	1.47	4.17	1.50	4.73	1.39	4.62	1.42	4.50	1.45	4.39	1.48	4.28	1.51	4.52	1.30	4.41	1.32	4.30	1.35	4.19	1.38	4.09	1.40	4.62	1.28	4.51	1.30	4.40	1.33	4.29	1.36	4.18	1.38

5. Fan performance

5-1. Air velocity distributions

■ Models: ASYG07KPCA and ASYG09KPCA

Measuring conditions	Fan speed	Operation mode
	HIGH	FAN

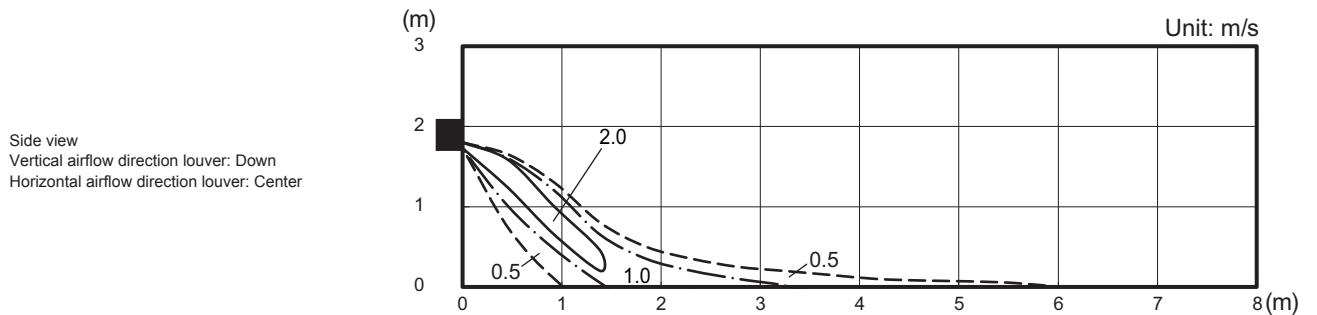
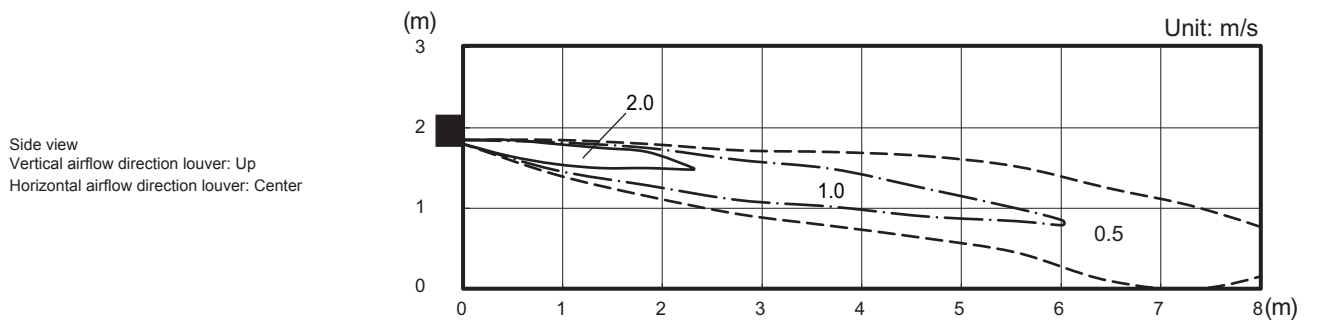
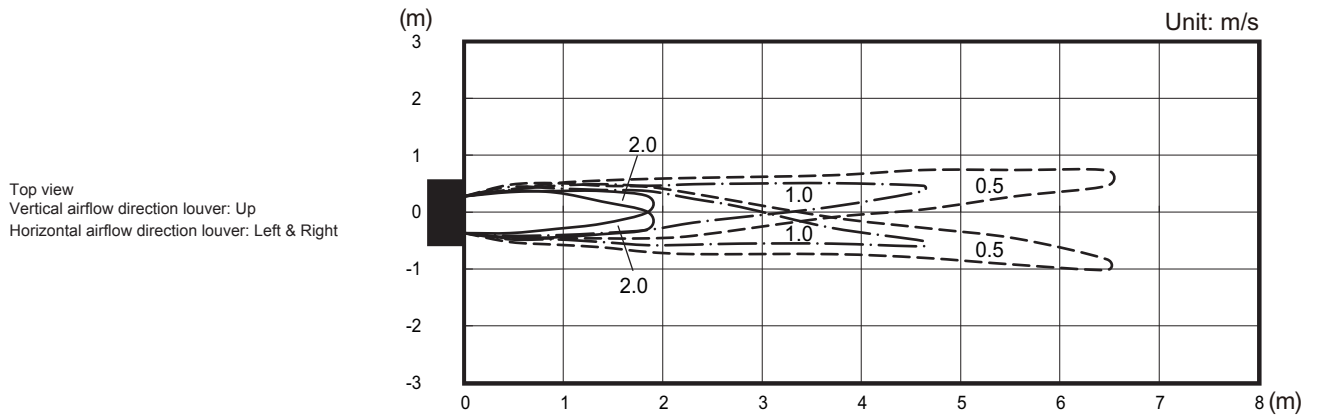
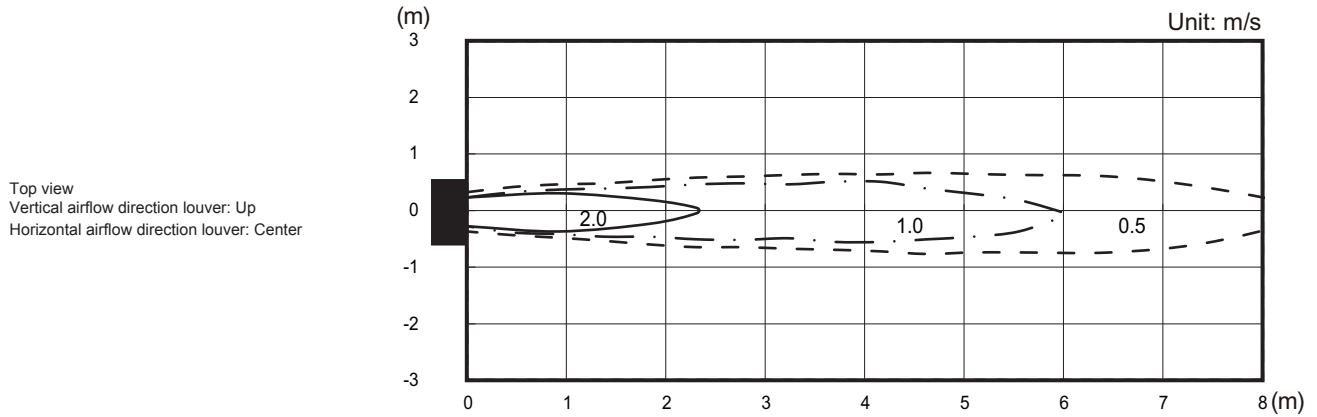

Model: ASYG12KPCA

Measuring conditions	Fan speed	Operation mode
	HIGH	FAN

Top view
Vertical airflow direction louver: Up
Horizontal airflow direction louver: Center

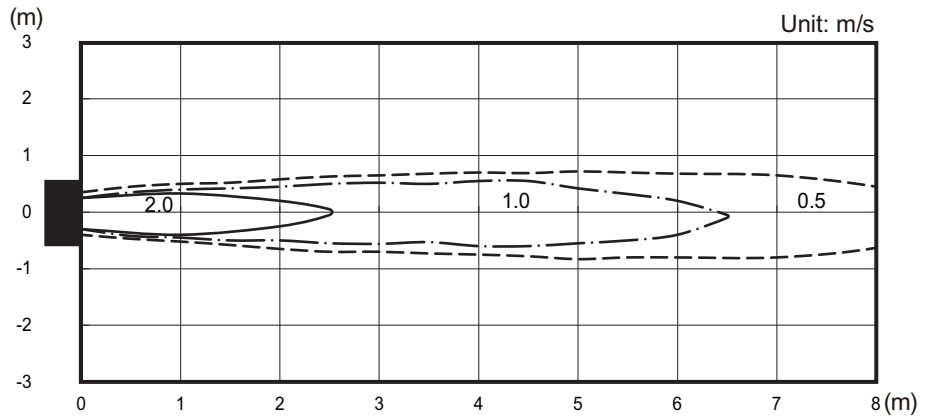

Top view
Vertical airflow direction louver: Up
Horizontal airflow direction louver: Left & Right

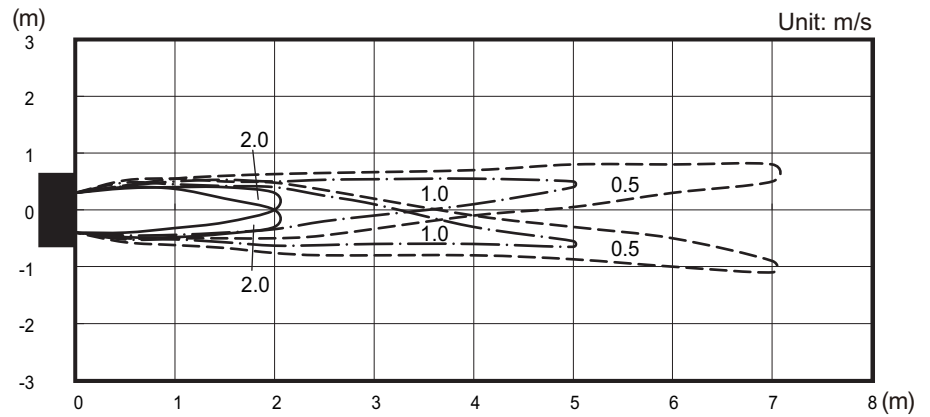

Side view
Vertical airflow direction louver: Up
Horizontal airflow direction louver: Center

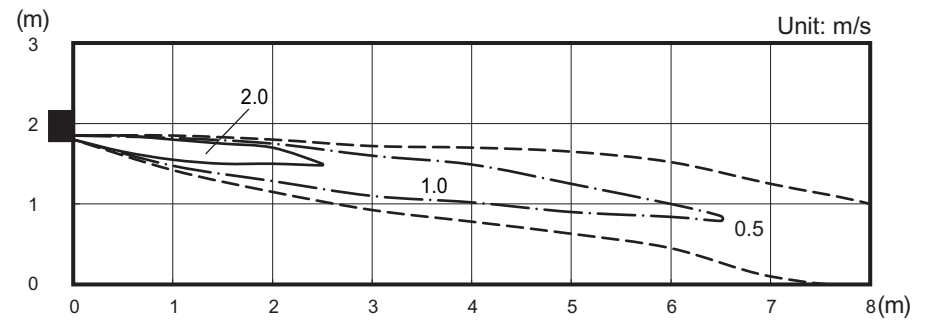

Side view
Vertical airflow direction louver: Down
Horizontal airflow direction louver: Center

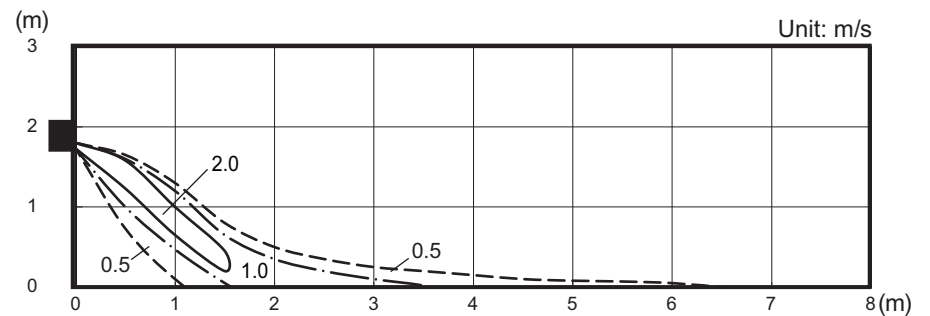

5-2. Airflow

■ Models: ASYG07KPCA and ASYG09KPCA

● Cooling

Fan speed	Airflow	
HIGH	m ³ /h	580
	l/s	161
	CFM	341
MED	m ³ /h	460
	l/s	128
	CFM	271
LOW	m ³ /h	340
	l/s	94
	CFM	200
QUIET	m ³ /h	240
	l/s	67
	CFM	141

● Heating

Fan speed	Airflow	
HIGH	m ³ /h	580
	l/s	161
	CFM	341
MED	m ³ /h	460
	l/s	128
	CFM	271
LOW	m ³ /h	380
	l/s	106
	CFM	224
QUIET	m ³ /h	260
	l/s	72
	CFM	153

■ Model: ASYG12KPCA

● Cooling

Fan speed	Airflow	
HIGH	m ³ /h	630
	l/s	175
	CFM	371
MED	m ³ /h	490
	l/s	136
	CFM	288
LOW	m ³ /h	360
	l/s	100
	CFM	212
QUIET	m ³ /h	240
	l/s	67
	CFM	141

● Heating

Fan speed	Airflow	
HIGH	m ³ /h	630
	l/s	175
	CFM	371
MED	m ³ /h	490
	l/s	136
	CFM	288
LOW	m ³ /h	380
	l/s	106
	CFM	224
QUIET	m ³ /h	260
	l/s	72
	CFM	153

6. Operation noise (sound pressure)

6-1. Noise level curve

Models: ASYG07KPCA and ASYG09KPCA

Cooling

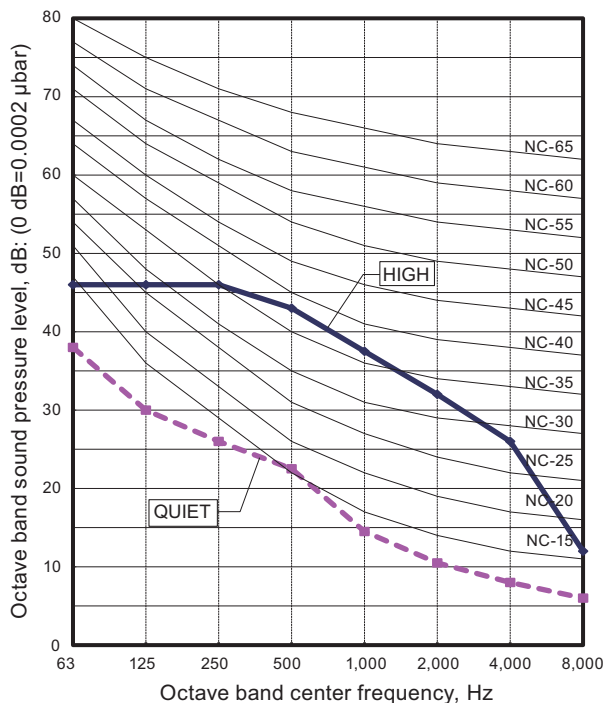

Heating

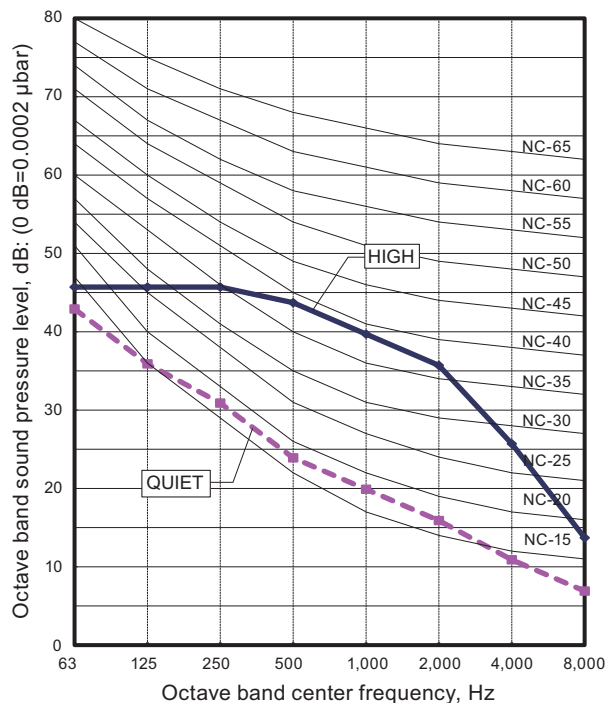

Model: ASYG12KPCA

Cooling

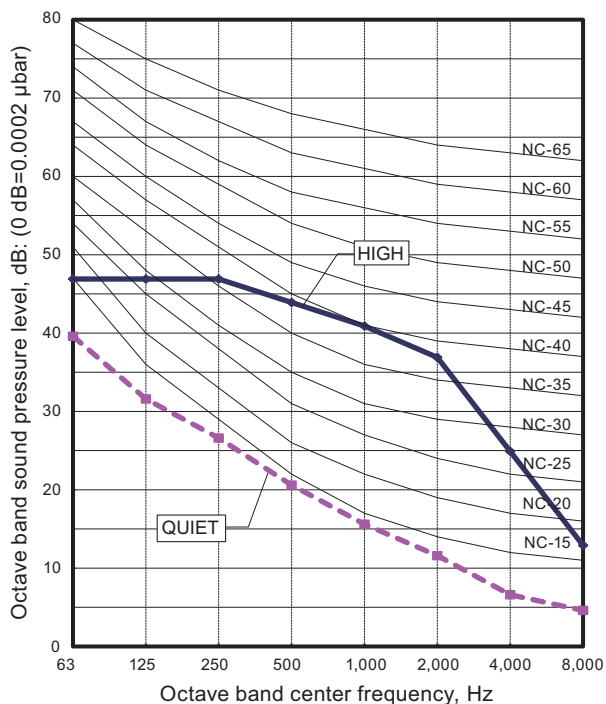

Heating

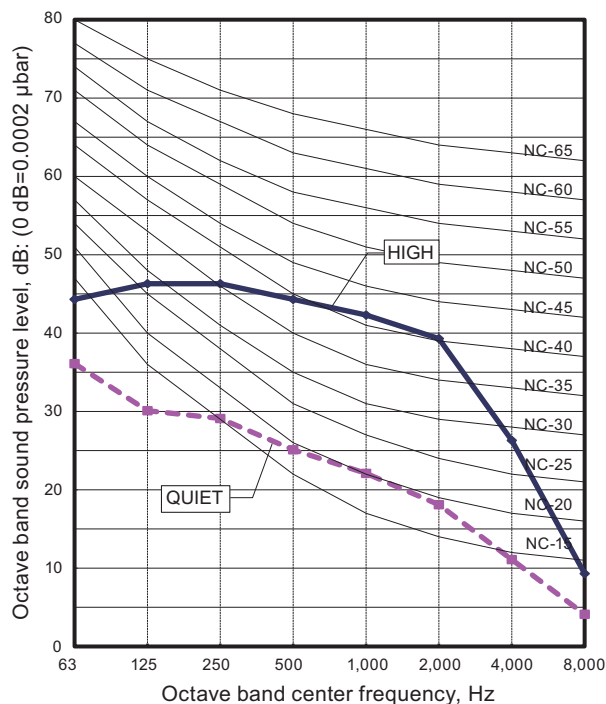

6-2. Sound level check point

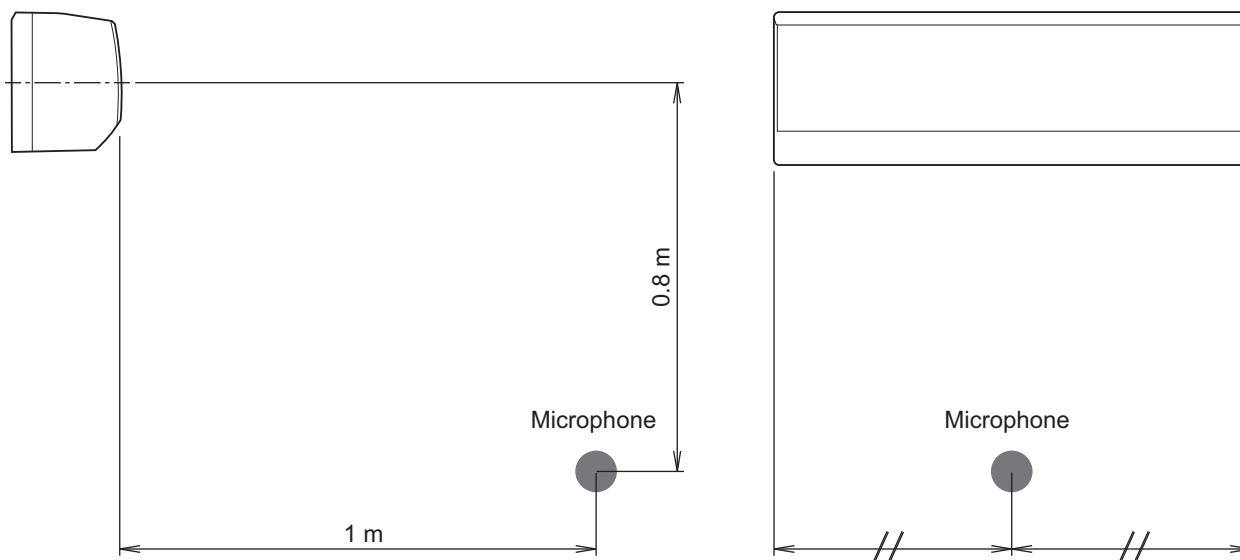

NOTE: Detailed shape of the actual indoor unit might be slightly different from the one illustrated above.

7. Safety devices

Type of protection	Protection form		Model		
			ASYG07KPCA	ASYG09KPCA	ASYG12KPCA
Circuit protection	Current fuse (PCB*)		250 V, 3.15 A		
Fan motor protection	Thermistor protection	Activate	More than 170 °C Fan motor stop		
		Reset	145 °C or less Fan motor restart		

*PCB: Printed Circuit Board

8. Remote controller

8-1. Wireless remote controller

Overview

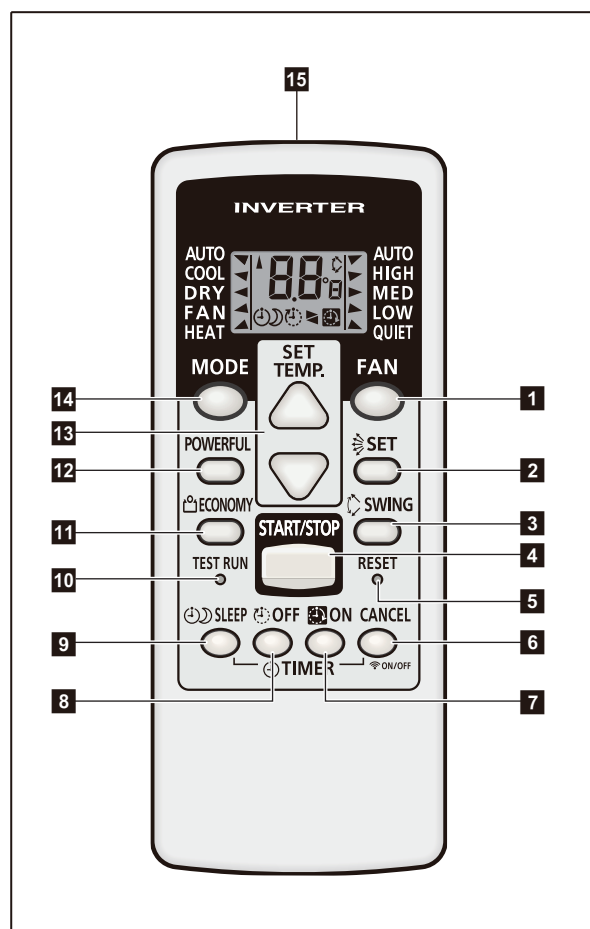

- 1 FAN button
- 2 SET button
- 3 SWING button
- 4 START/STOP button
- 5 RESET button
- 6 TIMER CANCEL/W-LAN ON/OFF button
- 7 ON TIMER/W-LAN SET button
- 8 OFF TIMER button
- 9 SLEEP TIMER button
- 10 TEST RUN button
 - Used only when installing the air conditioner, and should not be used under normal conditions, as it will cause the indoor unit's thermostat malfunction.
 - If this button is pressed during normal operation, the indoor unit will switch to test operation mode, and the operation indicator lamp and the timer indicator lamp on the indoor unit will begin to flash simultaneously.
 - To stop the test operation mode, press the START/STOP button. Then, the air conditioner stops the operation.

- 11 ECONOMY button
- 12 POWERFUL button
- 13 SET TEMP. (temperature) (▲ / ▼) button
 - Sets desired temperature.
 - Sets remote controller custom code.
- 14 MODE button
 - Switches operation mode (AUTO, COOL, DRY, FAN, and HEAT).
 - Starts/ends the remote controller custom code (max. 4 types) change.

- 15 Signal transmitter
- 16 Operating mode indicator
- 17 Signal transmit indicator
- 18 Temperature and time indicator
 - Displays set temperature.
 - In timer setting, it displays the timer time. After finishing the timer setting, set temperature will reappear.

- 19 Swing indicator
- 20 Fan speed indicator
- 21 Timer mode indicator

- Sleep timer
- OFF timer
- OFF-ON timer
- ON-OFF timer
- ON timer

Display panel

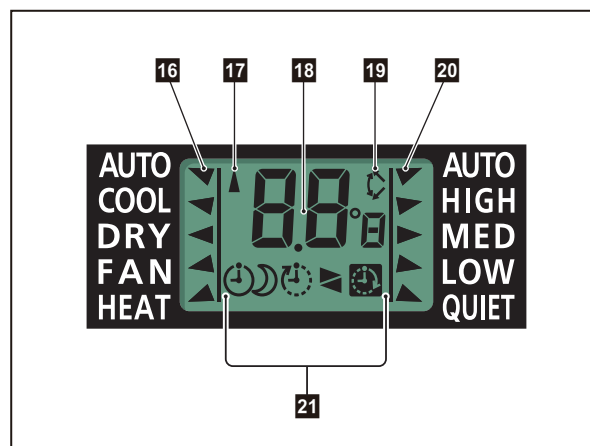

NOTE: Functions may differ by type of the indoor unit. For details, refer to the operation manual.

■ Specifications

● Controller

Unit: mm

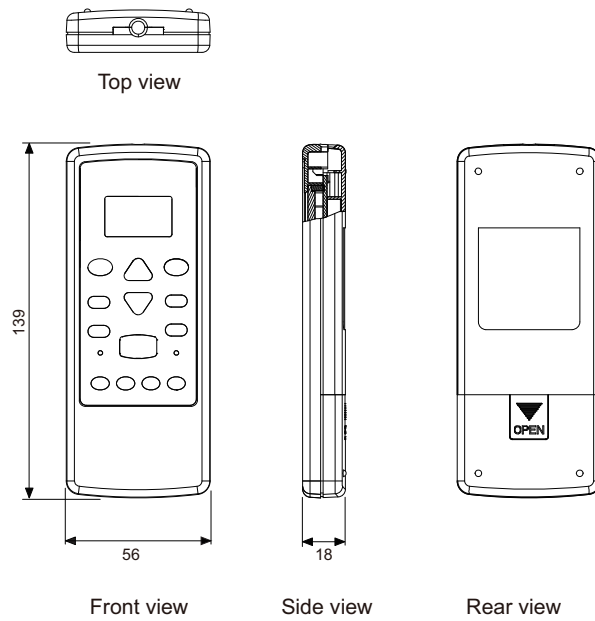

Size (H × W × D)	mm	139 × 56 × 18
Weight	g	70 (without batteries)

9. Function settings

To adjust the functions of this product according to the installation environment, various types of function settings are available.

NOTE: Incorrect settings can cause a product malfunction.

9-1. Function settings by using remote controller

Some function settings can be changed on the remote controller. After confirming the setting procedure and the content of each function setting, select appropriate functions for your installation environment.

■ Setting procedure by using wireless remote controller

The function number and the associated setting value are displayed on the LCD of the remote controller. Follow the instructions written in the local setup procedure supplied with the remote controller, and select appropriate setting according to the installation environment.

Before connecting the power supply of the indoor unit, reconfirm following items:

- Piping air tight test and vacuuming have been performed firmly.
- There is no wiring mistake.

Then, connect the power supply of indoor unit.

Entering function setting mode:

While pressing the FAN button and SET TEMP. (▲) button simultaneously, press the RESET button to enter the function setting mode.

STEP 1: Setting the remote controller custom code

Use the following steps to select the custom code of the remote controller. (Note that the air conditioner cannot receive a custom code if the air conditioner has not been set for the custom code.)

The custom codes that are set through this process are applicable only to the signal in the function setting.

For details on how to set the custom codes through the normal process, refer to ["Custom code setting"](#) on page 22.

1. Press the SET TEMP. (▲) (▼) buttons to change the custom code between $\text{A} \rightarrow \text{b} \rightarrow \text{c} \rightarrow \text{d}$. Match the code on the display to the air conditioner custom code. (Initially set to A .) If the custom code does not need to be selected, press the MODE button, and proceed to **STEP 2**.
2. Press the MODE button to accept the custom code, and proceed to **STEP 2**.

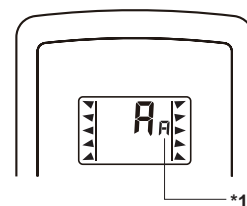

***1:** Small A is displayed on the right of the custom code during the function setting.

NOTES:

- The air conditioner custom code is set to A prior to shipment. To change the custom code, contact your retailer.
- The remote controller resets to custom code A when the batteries on the remote controller are replaced. If you use a custom code other than code A , reset the custom code after replacing the batteries.
- If you do not know the air conditioner custom code setting, try each of the custom codes ($\text{A} \rightarrow \text{b} \rightarrow \text{c} \rightarrow \text{d}$) until you find the code that operates the air conditioner.

STEP 2: Selecting the function number and setting value

1. Press the SET TEMP. (▲) (▼) buttons to select the function number. To switch between the left and right digits, press the MODE button.
2. Press the FAN button to proceed the setting value. To return the function number selection, press the FAN button again.
3. Press the SET TEMP. (▲) (▼) buttons to select the setting value. To switch between the left and right digits, press the MODE button.
4. Press the SLEEP button, then after you hear the beep emitted from the indoor unit, the START/STOP button in the order to confirm the settings.
5. Press the RESET button to cancel the function setting mode.
6. After completing the function setting, be sure to disconnect the power supply and then reconnect it.

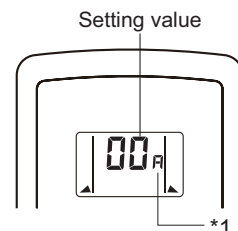
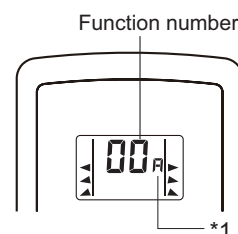

*1: Small  is displayed on the right of the custom code during the function setting.

 CAUTION

After disconnect the power supply, wait 30 seconds or more before reconnecting it. The function setting will not become active unless the power supply is disconnected and then reconnected.

■ Contents of function setting

Each function setting listed in this section is adjustable in accordance with the installation environment.

NOTE: Setting will not be changed if invalid numbers or setting values are selected.

● Function setting list

	Function no.	Functions
1)	11	Filter sign
2)	30/31	Room temperature control for indoor unit sensor
3)	40	Auto restart
4)	44	Remote controller custom code
5)	49	Indoor unit fan control for energy saving for cooling

1) Filter sign

Select appropriate intervals for displaying the filter sign on the indoor unit according to the estimated amount of dust in the air of the room.

If the indication is not required, select "No indication" (03).

Function number	Setting value	Setting description	Factory setting
11	00	Standard (400 hours)	
	01	Long interval (1,000 hours)	
	02	Short interval (200 hours)	
	03	No indication	◆

2) Room temperature control for indoor unit sensor

Depending on the installed environment, correction of the room temperature sensor may be required. Select the appropriate control setting according to the installed environment.

The temperature correction values show the difference from the Standard setting "00" (manufacturer's recommended value).

Function number	Setting value	Setting description	Factory setting		
30 (For cooling)	31 (For heating)	00	Standard setting	◆	
		01	No correction 0.0 °C		
		02	-0.5 °C	More cooling Less heating	
		03	-1.0 °C		
		04	-1.5 °C		
		05	-2.0 °C		
		06	-2.5 °C		
		07	-3.0 °C		
		08	-3.5 °C		
		09	-4.0 °C		
		10	+0.5 °C	Less cooling More heating	
		11	+1.0 °C		
		12	+1.5 °C		
		13	+2.0 °C		
		14	+2.5 °C		
		15	+3.0 °C		
		16	+3.5 °C		
17	+4.0 °C				

3) Auto restart

Enables or disables automatic restart after a power interruption.

Function number	Setting value	Setting description	Factory setting
40	00	Enable	◆
	01	Disable	

NOTE: Auto restart is an emergency function such as for power outage etc. Do not attempt to use this function in normal operation. Be sure to operate the unit by remote controller or external device.

4) Remote controller custom code

(Only for wireless remote controller)

The indoor unit custom code can be changed. Select the appropriate custom code.

Function number	Setting value	Setting description	Factory setting
44	00	A	◆
	01	B	
	02	C	
	03	D	

5) Indoor unit fan control for energy saving for cooling

Enables or disables the power-saving function by controlling the indoor unit fan rotation when the outdoor unit is stopped during cooling operation.

Function number	Setting value	Setting description	Factory setting
49	00	Disable	
	01	Enable	◆

00: When the outdoor unit is stopped, the indoor unit fan operates continuously following the setting on the remote controller.

01: When the outdoor unit is stopped, the indoor unit fan operates intermittently at a very low speed.

9-2. Custom code setting for wireless remote controller

■ Custom code setting

To interconnect the air conditioner and the wireless remote controller, assignment of the custom code for the wireless remote controller is required.

NOTE: Air conditioner cannot receive a custom code if the air conditioner has not been set for the custom code.

1. Press the MODE button for at least 5 seconds to display the current custom code. (Initially set to A .)

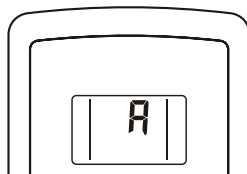





2. Press the SET TEMP. (\blacktriangle or \blacktriangledown) button to change the custom code between $\text{A} \rightarrow \text{b} \rightarrow \text{c} \rightarrow \text{d}$. Match the code on the display to the air conditioner custom code.
3. Press the MODE button again. The custom code will be changed.

NOTES:

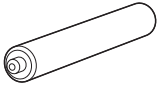

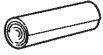
- If no button is pressed within 30 seconds after the custom code is displayed, the system returns to the original clock indicator. In this case, start again from step 1.
- The air conditioner custom code is set to A prior to shipment. To change the custom code, contact your retailer.
- The remote controller resets to custom code A when the batteries in the remote controller are replaced. If you use a custom code other than code A , reset the appropriate custom code after replacing the batteries. If you do not know the assigned code for the air conditioner, try each of the custom code ($\text{A} \rightarrow \text{b} \rightarrow \text{c} \rightarrow \text{d}$) until you find the code which operates the air conditioner.

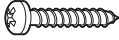
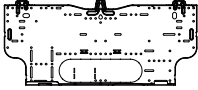
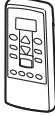
10. Accessories

Part name	Exterior	Q'ty	Part name	Exterior	Q'ty
Operating manual		1	Battery		2
Operating manual (CD-ROM)		1	Cloth tape		1
Installation manual		1	Tapping screw		5
Wall hook bracket		1	Remote controller		1

11. Optional parts

11-1. Others

Exterior	Part name	Model name	Summary
	Remote controller holder	UTZ-RXLA	Wall or pillar mountable, and holds the wireless remote controller.
	Wireless LAN adapter	UTY-TFSXF2	Remotely manage an air conditioning system using mobile devices such as smartphones and tablets.

Part 2. OUTDOOR UNIT

SINGLE TYPE:

AOYG07KPCA

AOYG09KPCA

AOYG12KPCA

1. Specifications

Type			Inverter heat pump		
Model name			AOYG07KPCA	AOYG09KPCA	AOYG12KPCA
Power supply			230 V ~ 50 Hz		
Power supply intake			Outdoor unit		
Available voltage range			198—264 V		
Starting current			A	3.2	3.8
Fan	Airflow rate	Cooling	m ³ /h	1,650	1,650
		Heating		1,450	1,450
	Type × Q'ty	Propeller fan × 1			
Motor output			W	23	
Sound pressure level *1	Cooling	dB (A)	45	47	49
			Heating	46	47
Sound power level	Cooling	dB (A)	57	59	62
			Heating	58	59
Heat exchanger type	Dimensions (H × W × D)		mm	504 × 650 × 18.2	
	Fin pitch			1.3	
	Rows × Stages		1 × 24		2 × 24
	Pipe type		Copper		
	Fin type	Type (Material)	Corrugate (Aluminum)		
Surface treatment		PC Fin			
Compressor	Type × Q'ty	DC Rotary × 1			
	Motor output	W	850		
Refrigerant	Type (Global warming potential)		R32 (675)		
	Charge	g	550	590	
Refrigerant oil	Type		POE		
	Amount	cm ³	240		
Enclosure	Material		Steel sheet		
	Color		Beige Approximate color of Munsell 10YR 7.5/1.0		
Dimensions (H × W × D)	Net		mm	541 × 663 × 290	
	Gross			596 × 798 × 369	
Weight	Net		kg	23	25
	Gross			25	27
Connection pipe	Size	Liquid	mm (in)	Ø 6.35 (1/4)	
		Gas		Ø 9.52 (3/8)	
	Method		Flare		
	Pre-charge length		m	15	
	Max. length			20	
Max. height difference		15			
Operation range	Cooling	°C	-10 to 46		
			Heating	-15 to 24	
Drain hose	Material		PP		
	Size		mm Ø 13.0 (I. D.), Ø 16.0 to Ø 16.8 (O. D.)		

NOTES:

- Specifications are based on the following conditions:
 - Cooling: Indoor temperature of 27 °CDB/19 °CWB, and outdoor temperature of 35 °CDB/24 °CWB.
 - Heating: Indoor temperature of 20 °CDB/15 °CWB, and outdoor temperature of 7 °CDB/6 °CWB.
 - Pipe length: 5 m, Height difference: 0 m.
- Protective function might work when using it outside the operation range.
- *1: Sound pressure level
 - Measured values in manufacturer's anechoic chamber.
 - Because of the surrounding sound environment, the sound levels measured in actual installation conditions might be higher than the specified values here.

2. Dimensions

2-1. Models: AOYG07KPCA, AOYG09KPCA, and AOYG12KPCA

Unit: mm

OUTDOOR UNIT
AOYG07-12KPCA

OUTDOOR UNIT
AOYG07-12KPCA

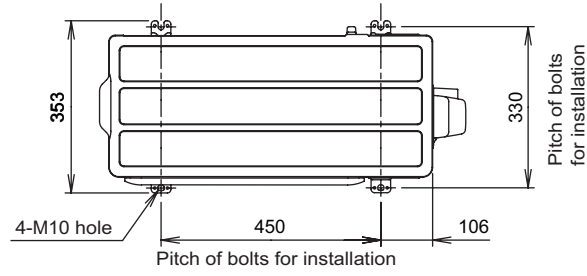

Top view

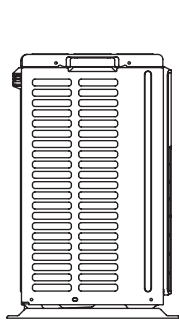

Side view

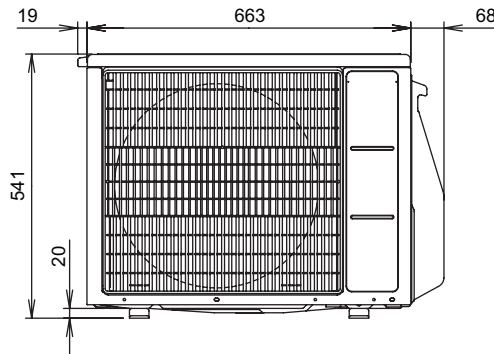

Front view

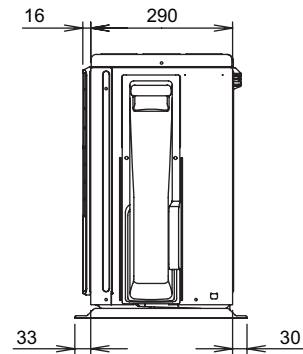

Side view

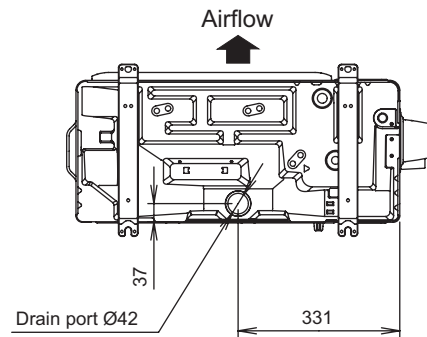

Bottom view

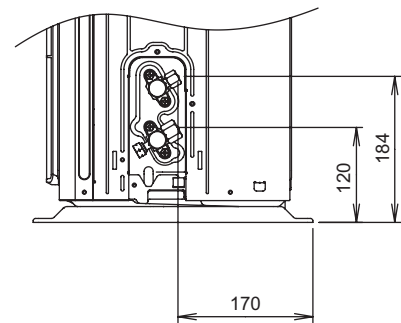

Side view (Valve part)

3. Installation space

3-1. Models: AOYG07KPCA, AOYG09KPCA, and AOYG12KPCA

■ Space requirement

Provide sufficient installation space for product safety.

⚠ CAUTION

Keep the space shown in the installation examples.

If the installation is not performed accordingly, it could cause a short circuit and result in a lack of operating performance.

● Single outdoor unit installation

- When the upper space is open:

Unit: mm

Obstacles at rear only

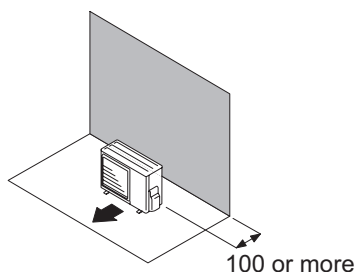

Obstacles at rear and sides

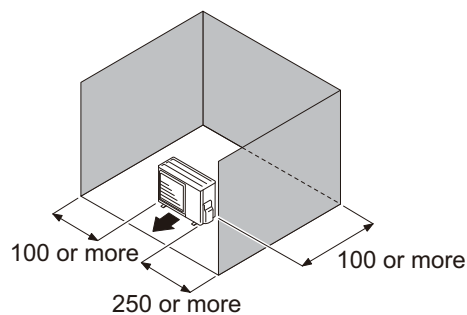

Obstacles at front

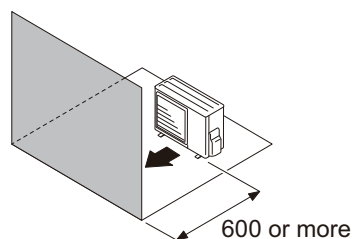

Obstacles at front and rear

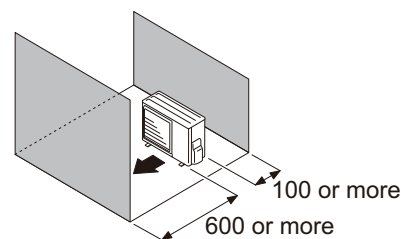

- When there is an obstruction in the upper space:

Unit: mm

Obstacles at rear and above

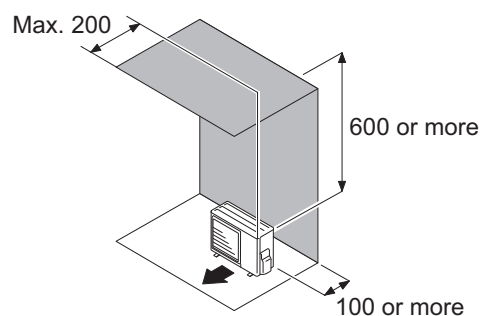

Obstacles at rear, sides, and above

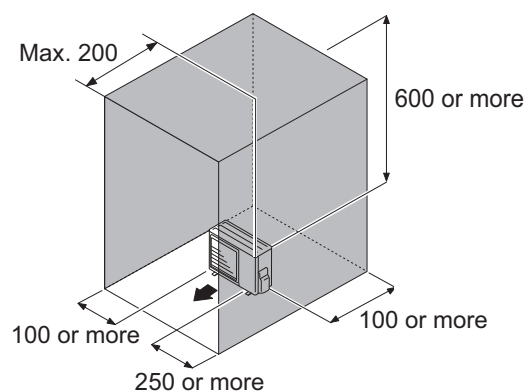

● Multiple outdoor unit installation

- Provide at least 250 mm of space between the outdoor units if multiple units are installed.
- When routing the piping from the side of an outdoor unit, provide space for piping.
- No more than 3 units must be installed side by side.
When 3 units or more are arranged in a line, provide the space as shown in the following example **“When an obstruction in the upper space:”**.
- **When the upper space is open:**

Unit: mm

Obstacles at rear only

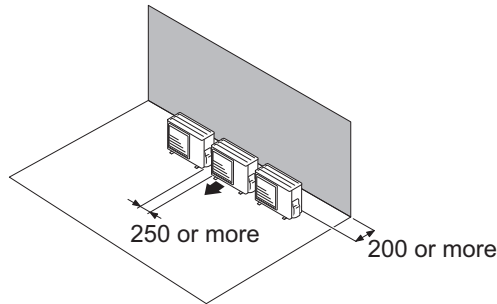

Obstacles at front only

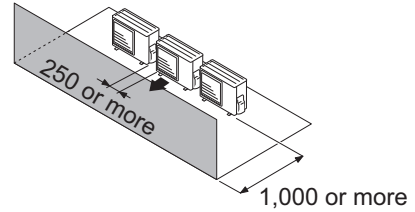

Obstacles at front and rear

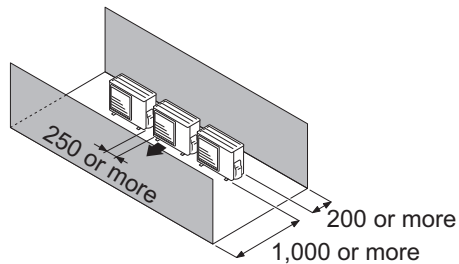

- **When an obstruction in the upper space:**

Unit: mm

Obstacles at rear and above.

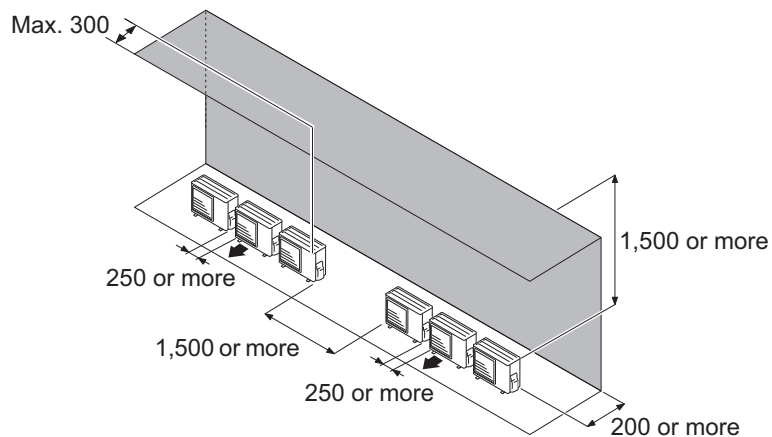

● Outdoor units installation in multi-row

Unit: mm

Single parallel unit arrangement

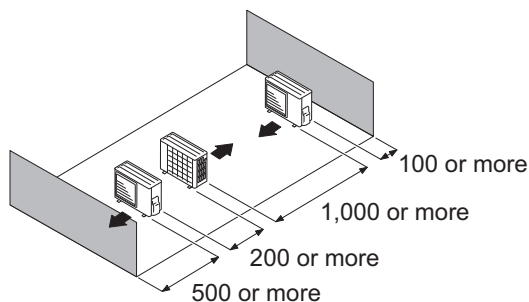

Multiple parallel unit arrangement

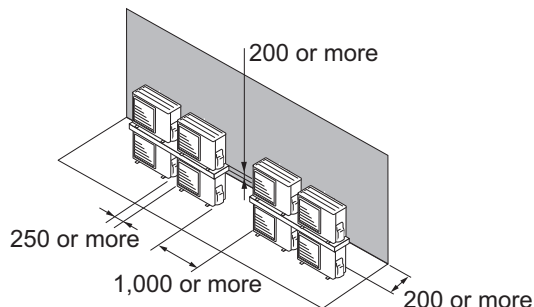
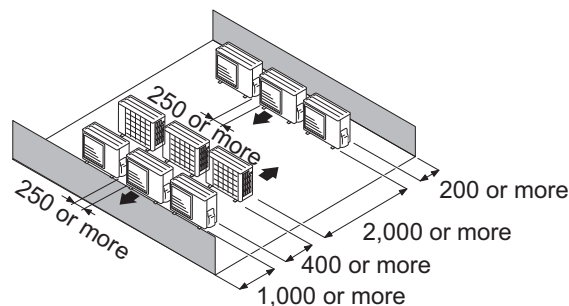

NOTES:

- If the space is larger than stated above, the condition will be the same as when there is no obstacle.
- When installing the outdoor unit, be sure to open the front and left side to obtain better operation efficiency.

⚠ CAUTION

- Do not install the outdoor unit in two-stage where the drain water could freeze. Otherwise the drainage from the upper unit may form ice and cause a malfunction of the lower unit.
- When the outdoor temperature is 0 °C or less, do not use the accessory drain pipe and drain cap. If the drain pipe and drain cap are used, the drain water in the pipe may freeze in extremely cold climate. (For reverse cycle model only.)
- In area with heavy snowfall, if the inlet and outlet of the outdoor unit is blocked with snow, it might become difficult to get warm, and it is likely to cause product malfunction. Construct a canopy and a pedestal, or place the unit on a high stand that is locally installed.

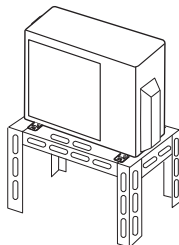

4. Refrigerant circuit

4-1. Models: AOYG07KPCA, AOYG09KPCA, and AOYG12KPCA

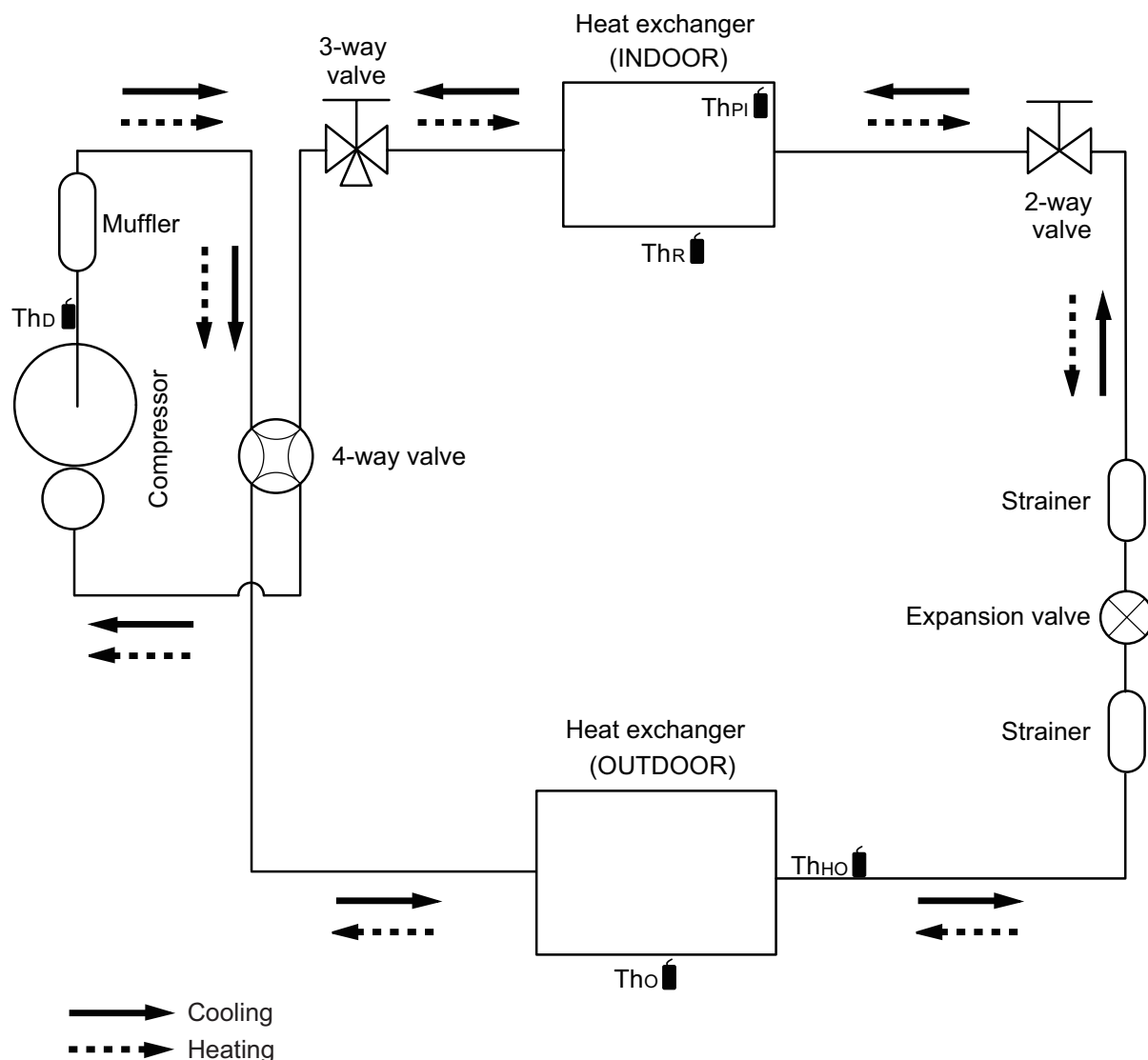

Th_D : Thermistor (Discharge temperature)

Th_O : Thermistor (Outdoor temperature)

Th_{HO} : Thermistor (Heat exchanger out temperature)

Th_R : Thermistor (Room temperature)

Th_{PI} : Thermistor (Pipe temperature)

5. Wiring diagrams

5-1. Models: AOYG07KPCA, AOYG09KPCA, and AOYG12KPCA

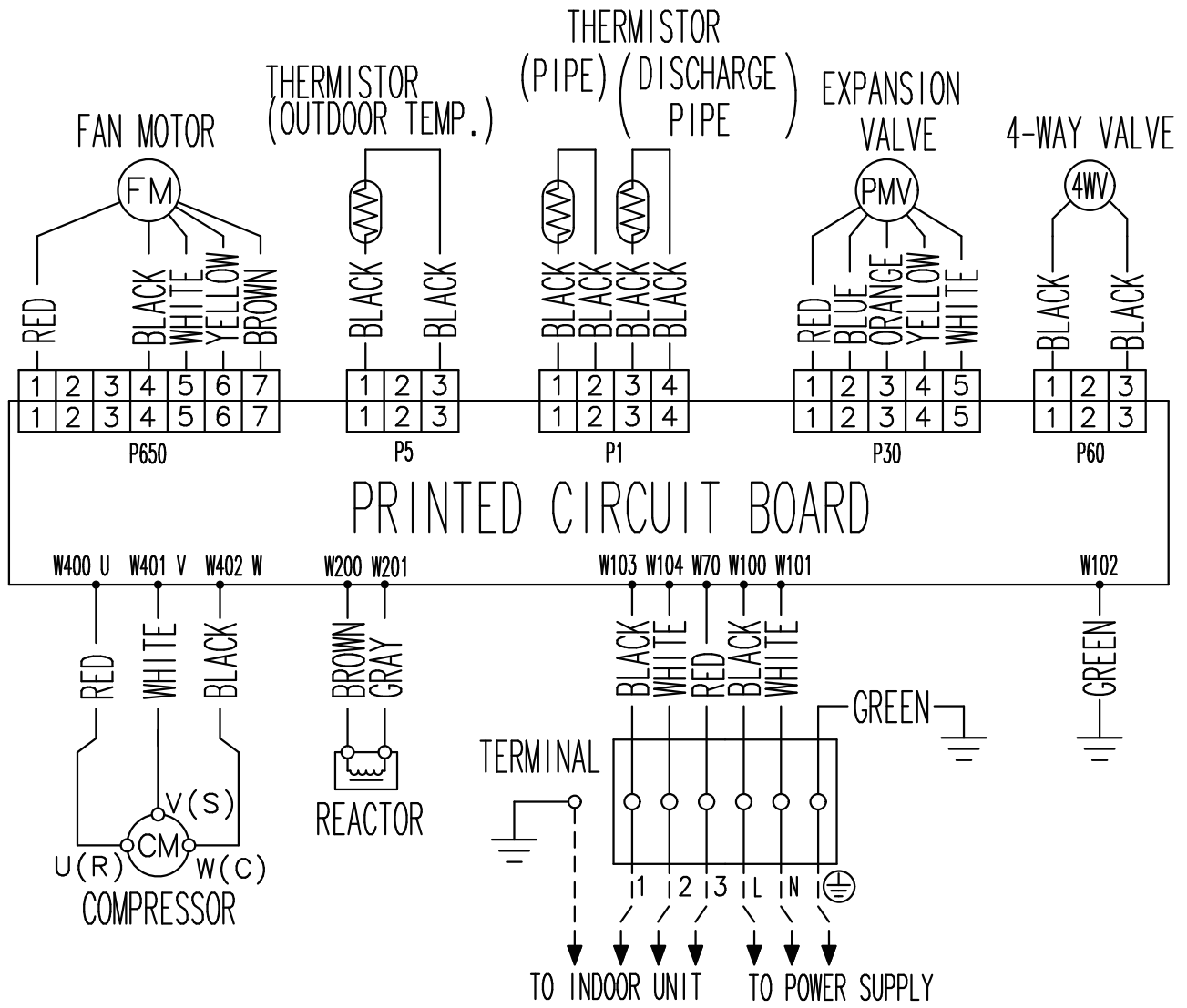

6. Capacity compensation rate for pipe length and height difference

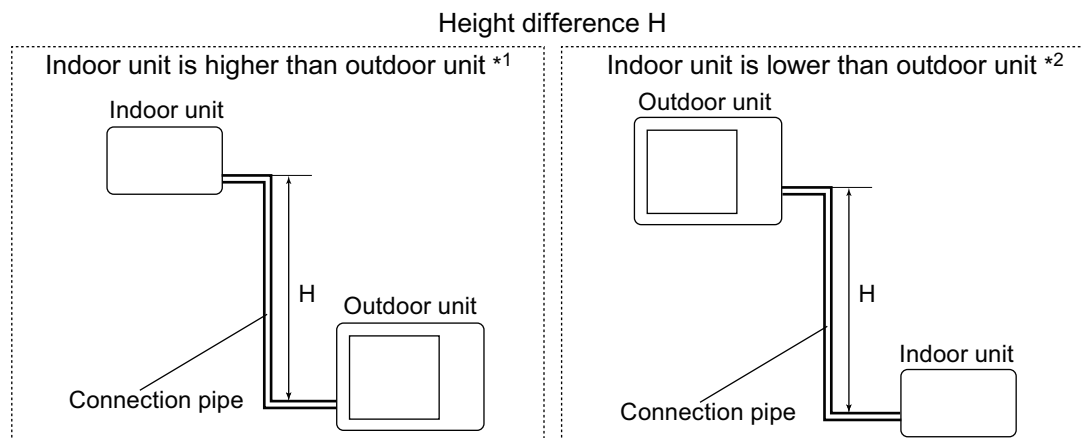

6-1. Models: AOYG07KPCA and AOYG09KPCA

NOTE: Values mentioned in the table are calculated based on the maximum capacity.

COOLING			Pipe length (m)				
			5	7.5	10	15	20
Height difference H (m)	Indoor unit is higher than outdoor unit *1	15	—	—	—	0.872	0.910
		10	—	—	0.961	0.886	0.925
		7.5	—	0.979	0.965	0.890	0.929
		5	0.992	0.983	0.969	0.893	0.933
	Indoor unit is lower than outdoor unit *2	0	1.000	0.991	0.976	0.901	0.940
		-5	1.000	0.991	0.976	0.901	0.940
		-7.5	—	0.991	0.976	0.901	0.940
		-10	—	—	0.976	0.901	0.940
		-15	—	—	—	0.901	0.940

HEATING			Pipe length (m)				
			5	7.5	10	15	20
Height difference H (m)	Indoor unit is higher than outdoor unit *1	15	—	—	—	0.832	0.822
		10	—	—	0.917	0.832	0.822
		7.5	—	0.961	0.917	0.832	0.822
		5	1.000	0.961	0.917	0.832	0.822
	Indoor unit is lower than outdoor unit *2	0	1.000	0.961	0.917	0.832	0.822
		-5	0.955	0.956	0.912	0.828	0.818
		-7.5	—	0.954	0.910	0.826	0.816
		-10	—	—	0.908	0.824	0.814
		-15	—	—	—	0.815	0.805

6-2. Model: AOYG12KPCA

NOTE: Values mentioned in the table are calculated based on the maximum capacity.

COOLING			Pipe length (m)				
			5	7.5	10	15	20
Height difference H (m)	Indoor unit is higher than outdoor unit *1	15	—	—	—	0.858	0.868
		10	—	—	0.929	0.872	0.882
		7.5	—	0.960	0.933	0.876	0.885
		5	0.992	0.964	0.937	0.879	0.889
	Indoor unit is lower than outdoor unit *2	0	1.000	0.972	0.944	0.887	0.896
		-5	1.000	0.972	0.944	0.887	0.896
		-7.5	—	0.972	0.944	0.887	0.896
		-10	—	—	0.944	0.887	0.896
		-15	—	—	—	0.887	0.896

HEATING			Pipe length (m)				
			5	7.5	10	15	20
Height difference H (m)	Indoor unit is higher than outdoor unit *1	15	—	—	—	0.896	0.879
		10	—	—	0.968	0.890	0.879
		7.5	—	0.994	0.968	0.896	0.879
		5	1.000	0.994	0.968	0.896	0.879
	Indoor unit is lower than outdoor unit *2	0	1.000	0.994	0.968	0.896	0.879
		-5	0.995	0.989	0.963	0.891	0.875
		-7.5	—	0.987	0.961	0.889	0.873
		-10	—	—	0.959	0.887	0.871
		-15	—	—	—	0.878	0.862

7. Additional charge calculation

7-1. Models: AOYG07KPCA and AOYG09KPCA

Refrigerant type		R32
Refrigerant amount	g	550

■ Refrigerant charge

Total pipe length	m	15 or less	20 (Max.)	20 g/m
Additional charge	g	0	100	

7-2. Model: AOYG12KPCA

Refrigerant type		R32
Refrigerant amount	g	590

■ Refrigerant charge

Total pipe length	m	15 or less	20 (Max.)	20 g/m
Additional charge	g	0	100	

8. Airflow

8-1. Model: AOYG07KPCA

● Cooling

Airflow	
m ³ /h	1,650
l/s	458
CFM	971

● Heating

Airflow	
m ³ /h	1,450
l/s	403
CFM	853

8-2. Model: AOYG09KPCA

● Cooling

Airflow	
m ³ /h	1,650
l/s	458
CFM	971

● Heating

Airflow	
m ³ /h	1,450
l/s	403
CFM	853

8-3. Model: AOYG12KPCA

● Cooling

Airflow	
m ³ /h	1,700
l/s	472
CFM	1,001

● Heating

Airflow	
m ³ /h	1,470
l/s	408
CFM	865

9. Operation noise (sound pressure)

9-1. Noise level curve

Model: AOYG07KPCA

● Cooling

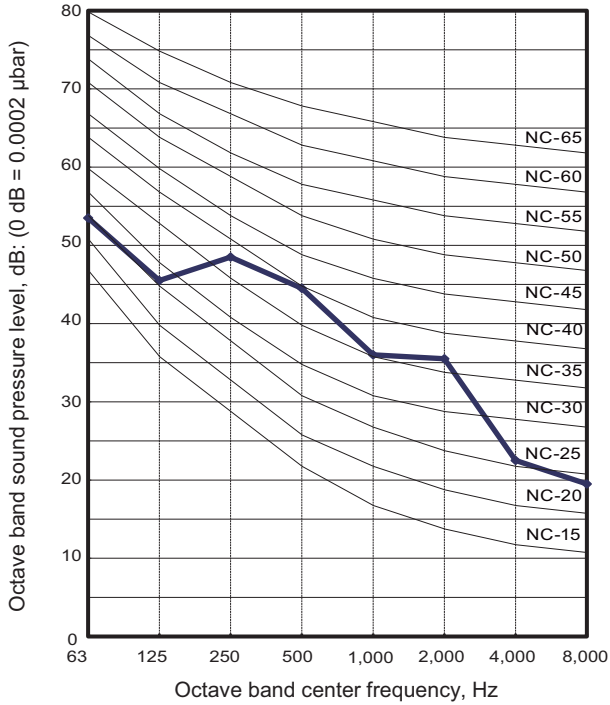

● Heating

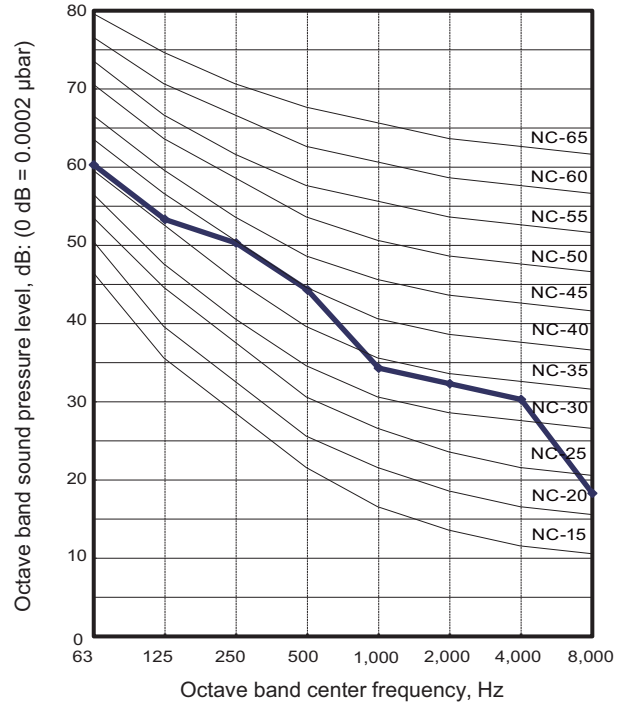

Model: AOYG09KPCA

● Cooling

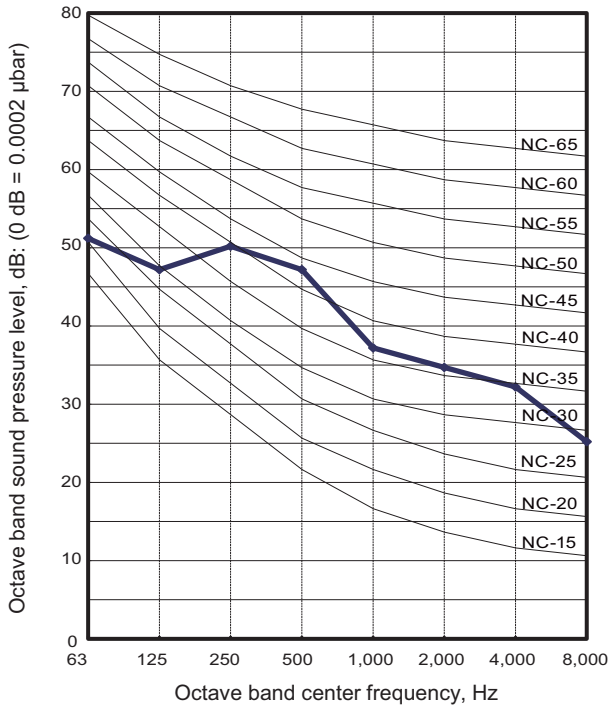

● Heating

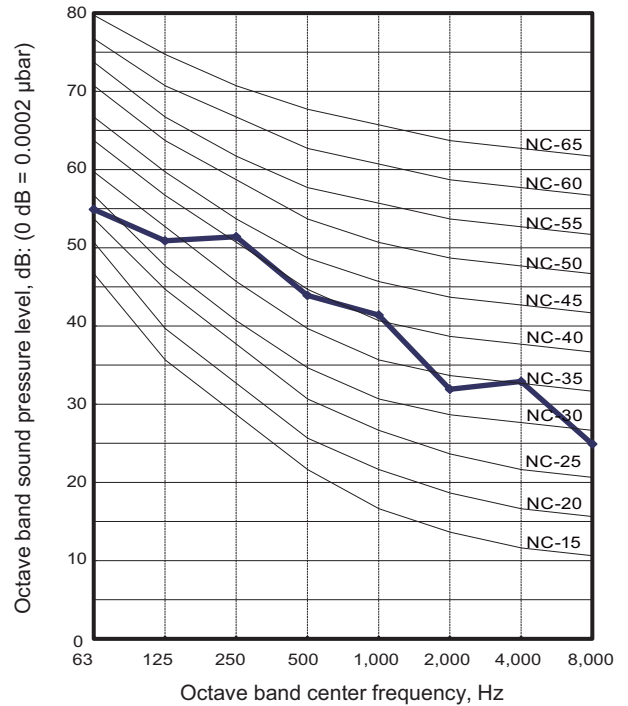

OUTDOOR UNIT
AOYG07-12KPCA

OUTDOOR UNIT
AOYG07-12KPCA

Model: AOYG12KPCA

● Cooling

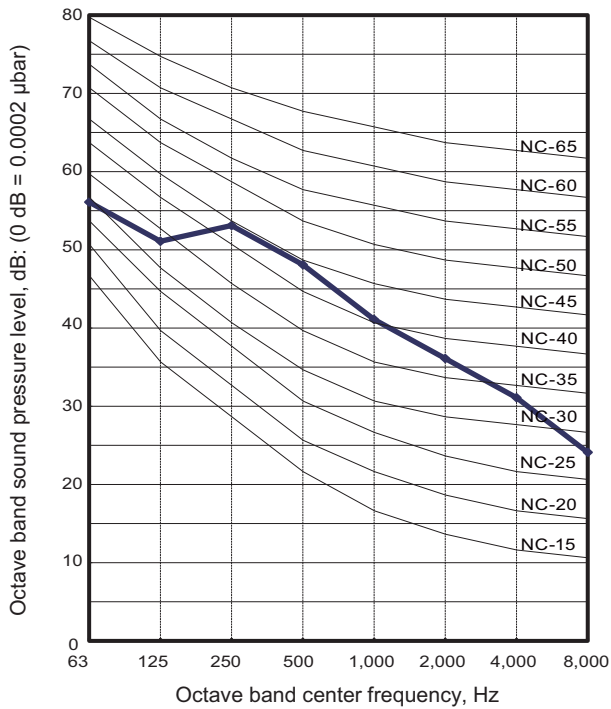

● Heating

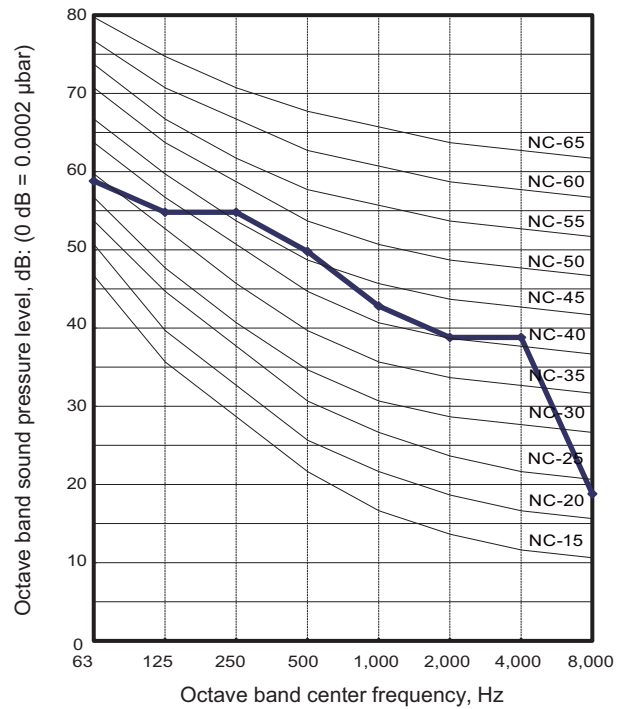

OUTDOOR UNIT
AOYG07-12KPCA

OUTDOOR UNIT
AOYG07-12KPCA

9-2. Sound level check point

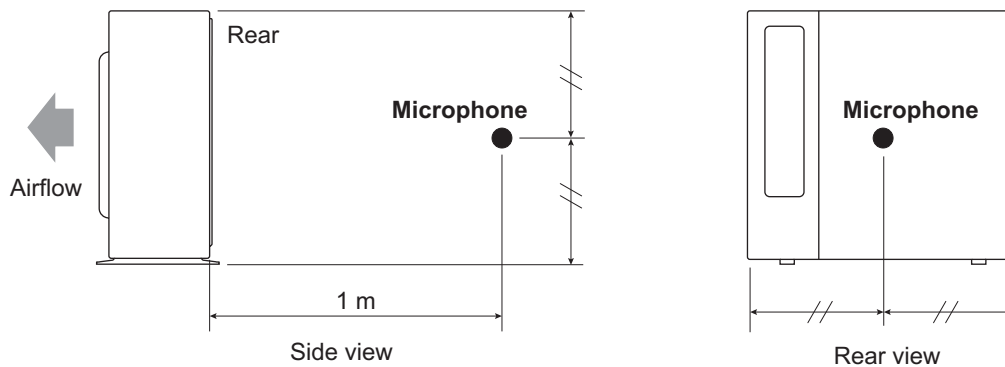

NOTE: Detailed shape of the actual outdoor unit might be slightly different from the one illustrated above.

10. Electrical characteristics

Model name			AOYG07KPCA	AOYG09KPCA	AOYG12KPCA
Power supply	Voltage	V	230 ~		
	Frequency	Hz	50		
Max operating current *1		A	9.0	9.0	9.0
Starting current		A	3.2	3.8	5.6
Wiring spec. *2	Circuit breaker current		A	15	
	Power cable		mm ²	1.5	
	Connection cable *3	Cross-sectional area	mm ²	1.5	
		Limited wiring length	m	21	

*1: Maximum operating current is the total current of the indoor unit and the outdoor unit.

*2: Selected sample based on Japan Electrotechnical Standards and Codes Committee E0005. As the regulations of wire size and circuit breaker differ in each country or region, select appropriate devices complied to the regional standard.

*3: Limit voltage drop to less than 2%. If voltage drop is 2% or more, increase cable conductor size.

11. Safety devices

Type of protection	Protection form		Model		
			AOYG07KPCA	AOYG09KPCA	AOYG12KPCA
Circuit protection	Current fuse (Main PCB)		250 V, 20 A 250 V, 5 A		
Fan motor protection	Thermistor protection	Activate	85—122 °C Fan motor stop		
		Reset	77—114 °C Fan motor restart		
Compressor protection	Terminal protection program (Discharge temp.)	Activate	110 °C Compressor stop		
		Reset	After 7 minutes Compressor restart		
	Thermal protection program (Outdoor temp.)	Activate	COOL or DRY: -15 °C HEAT: -20 °C Compressor stop		
		Reset	COOL or DRY: -10 °C HEAT: -15 °C Compressor restart		

12. Accessories

12-1. Models: AOYG07KPCA, AOYG09KPCA, and AOYG12KPCA

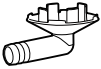
Part name	Exterior	Q'ty	Part name	Exterior	Q'ty
Drain pipe		1			