

GoDEX

RT700/RT730 BARCODE PRINTER USER MANUAL



CONTENTS

1	Barcode Printer	001
1.1	Box Content	001
1.2	Getting to Know Your Printer	002
2	Printer Setup	006
2.1	Open the Printer	006
2.2	Loading the Ribbon	007
2.3	Loading the Label Roll Module	012
2.4	Connecting the Printer to the Host Computer	014
2.5	Installing Printer Driver and GoLabel with Super Wizard CD	016
3	Printer Setting and Control	021
3.1	Operation Panel	021
3.2	Label Calibration and Self Test	022
3.3	Error Alerts	024
4	NetSetting for Ethernet	025
4.1	Installing the NetSetting Software	025
4.2	The Interface of NetSetting	026
5	Accessories	033
5.1	Preparation Steps	033
5.2	Installing the Label Dispenser	035
5.3	Installing the Cutter	041
6	Maintenance and Adjustment	045
6.1	Cleaning the Print Head	045
6.2	Troubleshooting	046
	Appendix	
	Product Specifications	
	Interface	

FCC COMPLIANCE STATEMENT FOR AMERICAN USERS

This equipment has been tested and found to comply with the limits for a CLASS A digital device, pursuant to Part 15 of the FCC Rules. These limits are designed to provide reasonable protection against harmful interference when the equipment is operated in a commercial environment. This equipment generates, uses, and can radiate radio frequency energy and, if not installed and used in accordance with the instructions, may cause harmful interference to radio communications. Operation of this equipment in a residential area is likely to cause harmful interference in which case the user will be required to correct the interference at own expense.

EMS AND EMI COMPLIANCE STATEMENT FOR EUROPEAN USERS

This equipment has been tested and passed with the requirements relating to electromagnetic compatibility based on the standards EN55022:2010 Class A, EN61000-3-2:2006/A1:2009/A2:2009, EN 61000-3-3:2008 and EN55024:2010, IEC 61000-4-2:2008 series. The equipment also tested and passed in accordance with the European Standard EN55022 for the both Radiated and Conducted emissions limits.

RT700 SERIES TO WHICH THIS DECLARATION RELATES IS IN CONFORMITY WITH THE FOLLOWING STANDARDS

IEC 60950-1:2005(2nd Edition)+Am 1:2009, CB9254-2008 (Class A) ; GB17625. 1-2003; GB4943.1-2011, EN55022:2010 Class A, EN61000-3-2:2006/A1:2009/A2:2009, EN 61000-3-3:2008 and EN55024:2010, IEC 61000-4-2:2008 series, UL 60950-1, 2nd Edition, 2011-12-19, CSA C22.2 No. 60950-1-07, 2nd Edition, 2011-12, CFR 47, Part 15

WARNING

This is a Class A product. In a domestic environment this product may cause radio interference in which case the user may be required to take adequate measures.

此为Class A产品·在生活环境中·该产品可能造成无线电干扰·在这种情况下·可能需要用户对其干扰采取切实可行的措施。

이 기기는 업무용으로 전자파적합등록을 한 기기이오니 판매자또는 사용자는 이점을 주의하시기 바라며, 만약 잘못된 판매 또는 구입하였을 때에는 가정용으로 교환하시기 바랍니다.

SAFETY INSTRUCTIONS

Please read the following instructions carefully.

1. Keep the equipment away from humidity.
2. Before you connect the equipment to the power outlet, please check the voltage of the power source.
3. Make sure the printer is off before plugging the power connector into the power jack.
4. It is recommended that you connect the printer to a surge protector to prevent possible transient overvoltage damage.
5. Be careful not to get liquid on the equipment to avoid electrical shock.
6. For safety and warranty reasons, ONLY qualified service personnel should open the equipment.
7. Do not repair or adjust energized equipment under any circumstances.

Caution

- * Danger of explosion if battery is incorrectly replaced. Replace only with the equivalent type recommended by the manufacturer.
- ** Dispose of used batteries according to the manufacturer's instructions.
- *** Only use with designated power supply adapter model.
- **** Changes or modifications not expressly approved by the party responsible for compliance could void the user's authority to operate the equipment.

Specifications are subject to change without notice.

1 Barcode Printer

1.1 Box Content

Please check that all of the following items are included with your printer.

- RT700/RT730 Barcode Printer

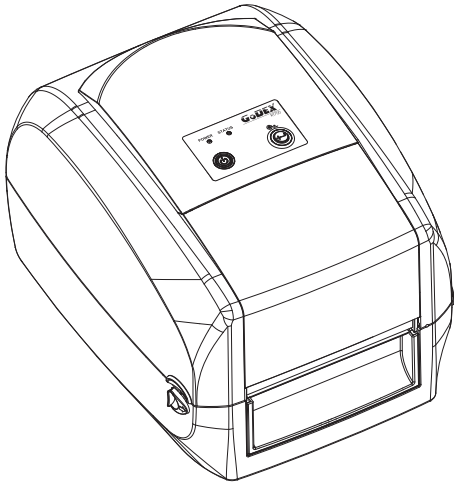

- Label Stock

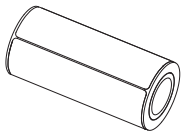

- USB Cable

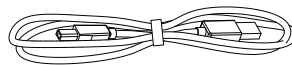

- RT700/RT730 Quick Guide



- Ribbon Module
Empty Ribbon Core

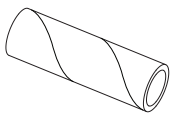

- Power Adapter
Power Cord

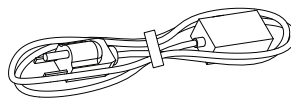

Ribbon

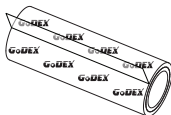

AC Adapter

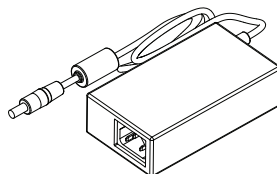

Ribbon Hubs
Set of 2.

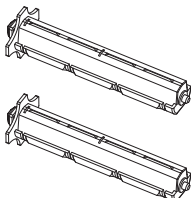

- CD
Including GoLabel software
and RT700/RT730 user manual.

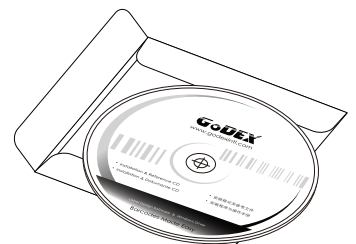

1 Barcode Printer

1.2 Getting to Know Your Printer

Device Overview

- Front View

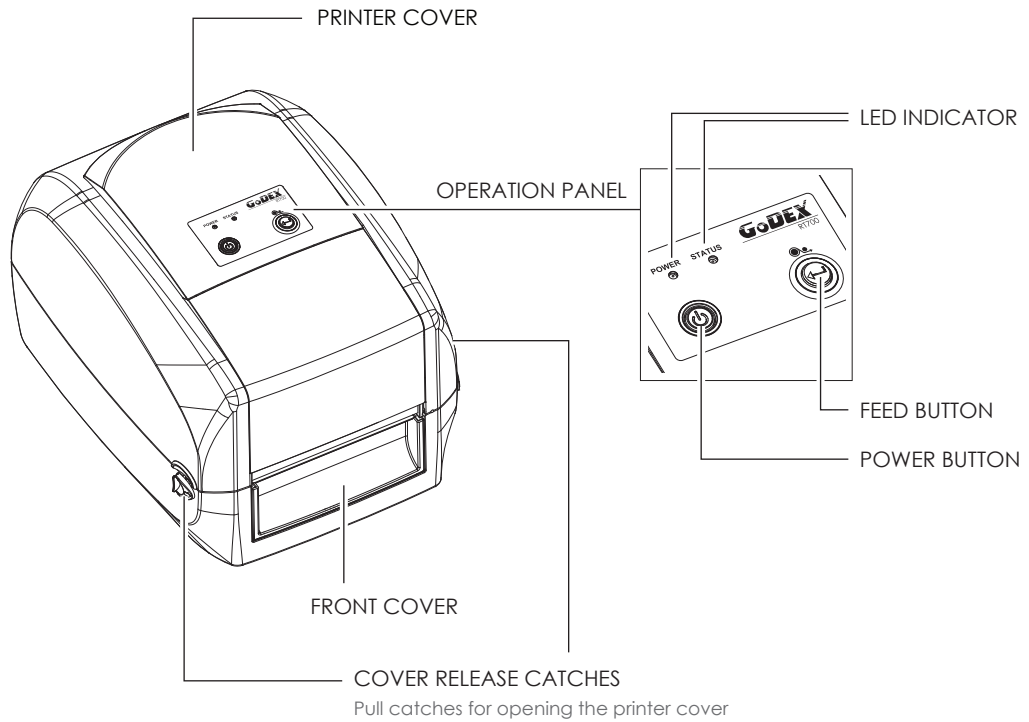

- Rear View

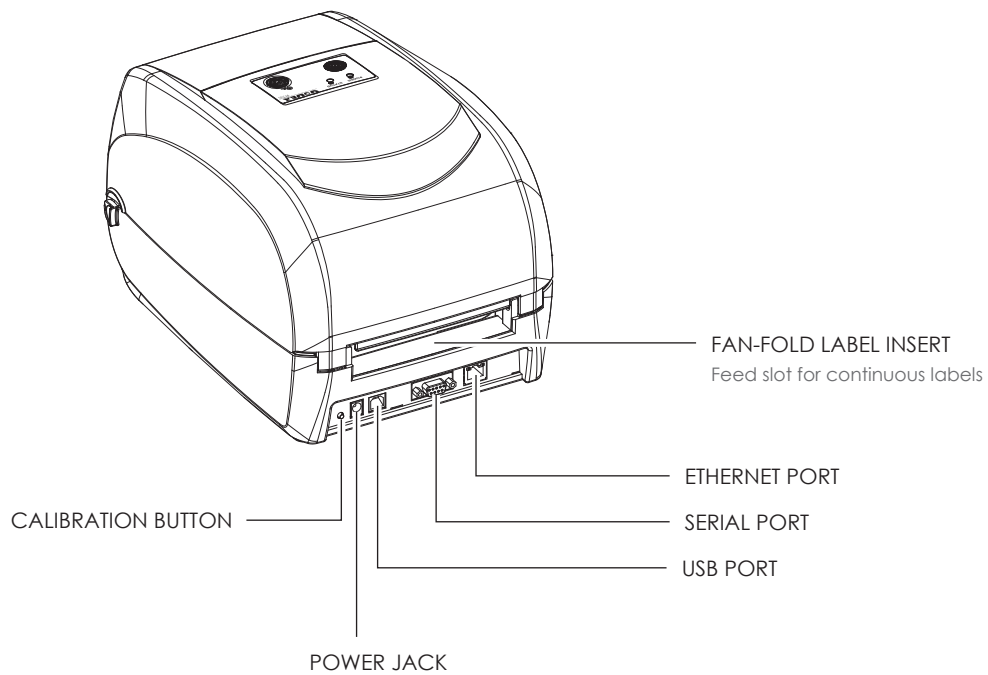

1 Barcode Printer

- Bottom View

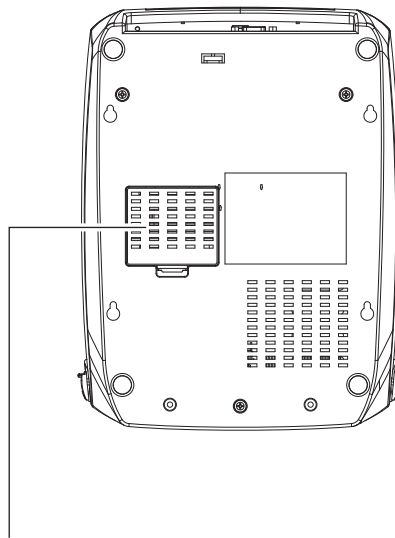

COVER OF THE MODULE CONNECTION JACKS

Notice

- * Cut-outs are not intended for wall-mount use.

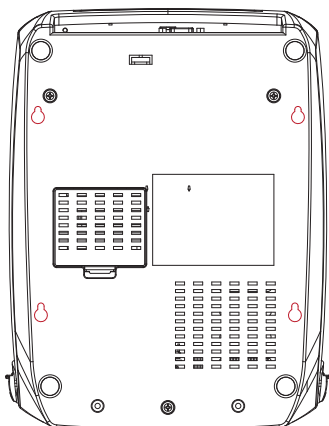

1 Barcode Printer

The Internal View of Printer

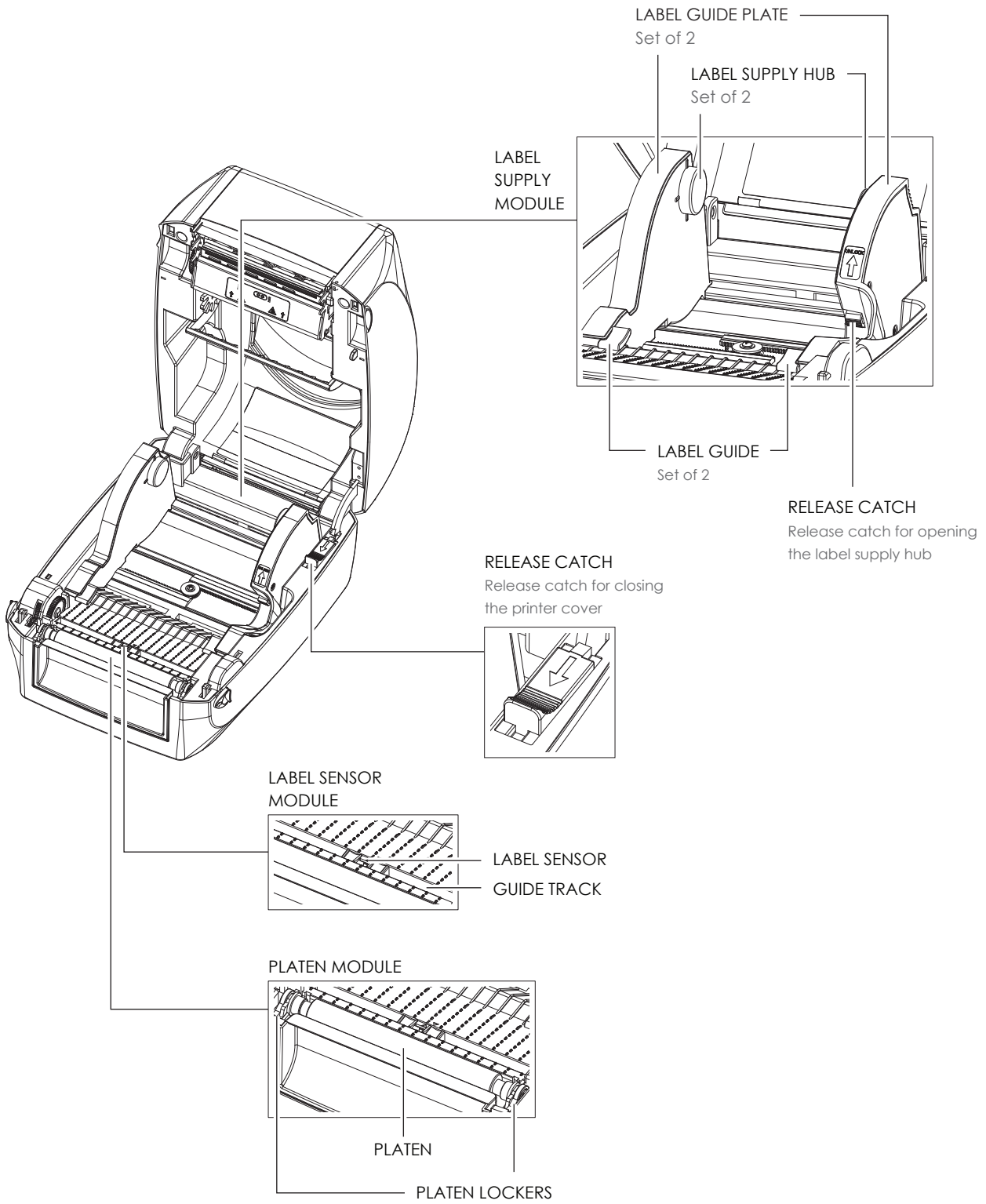

1 Barcode Printer

The Printing Mechanism

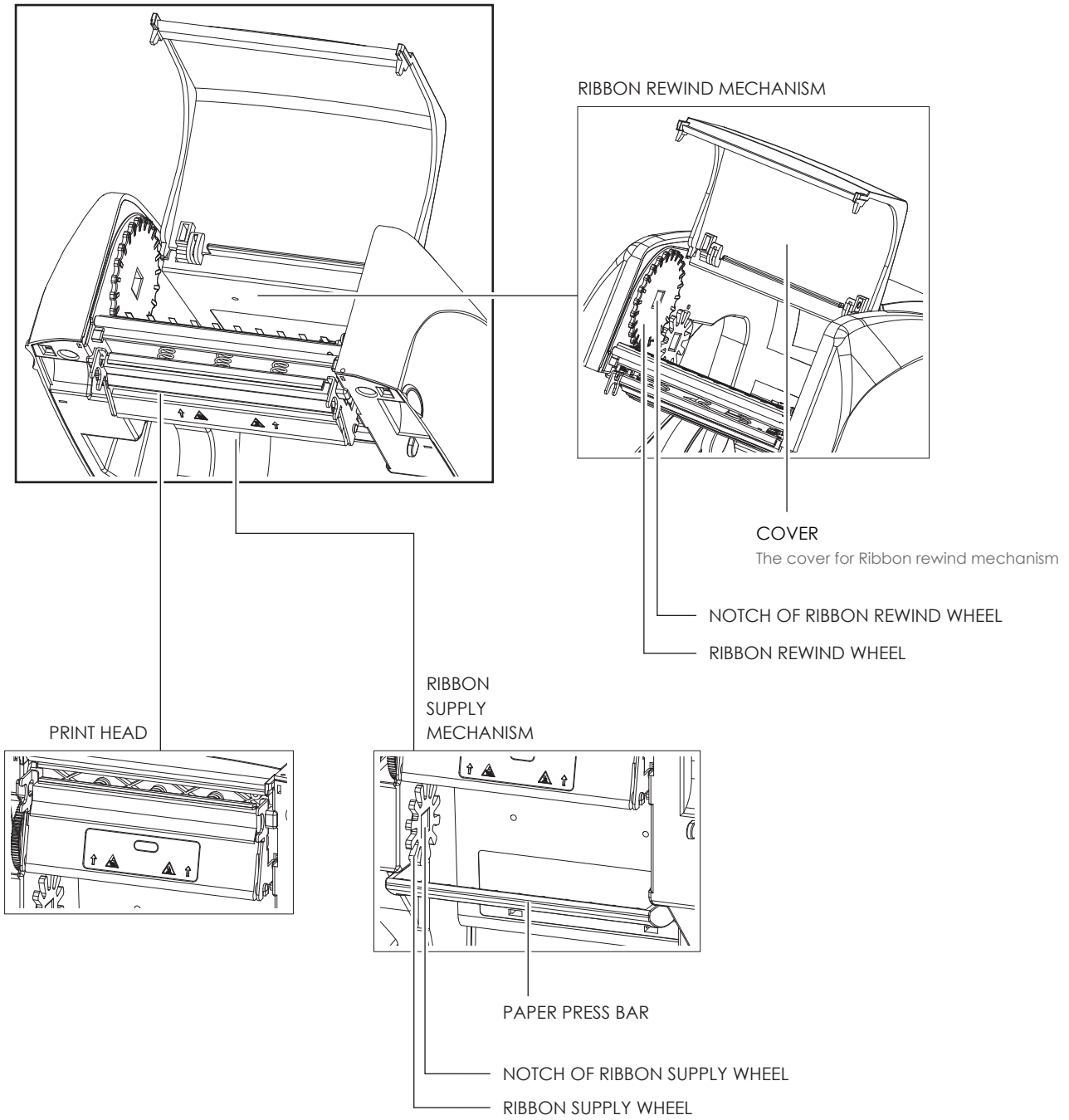

2 Printer Setup

2.1 Open the Printer

Open the Printer Cover and the Printing Mechanism

Place the printer on a flat surface. Open the printer cover by pulling the cover release catches on both sides of the printer and lift the printer cover.

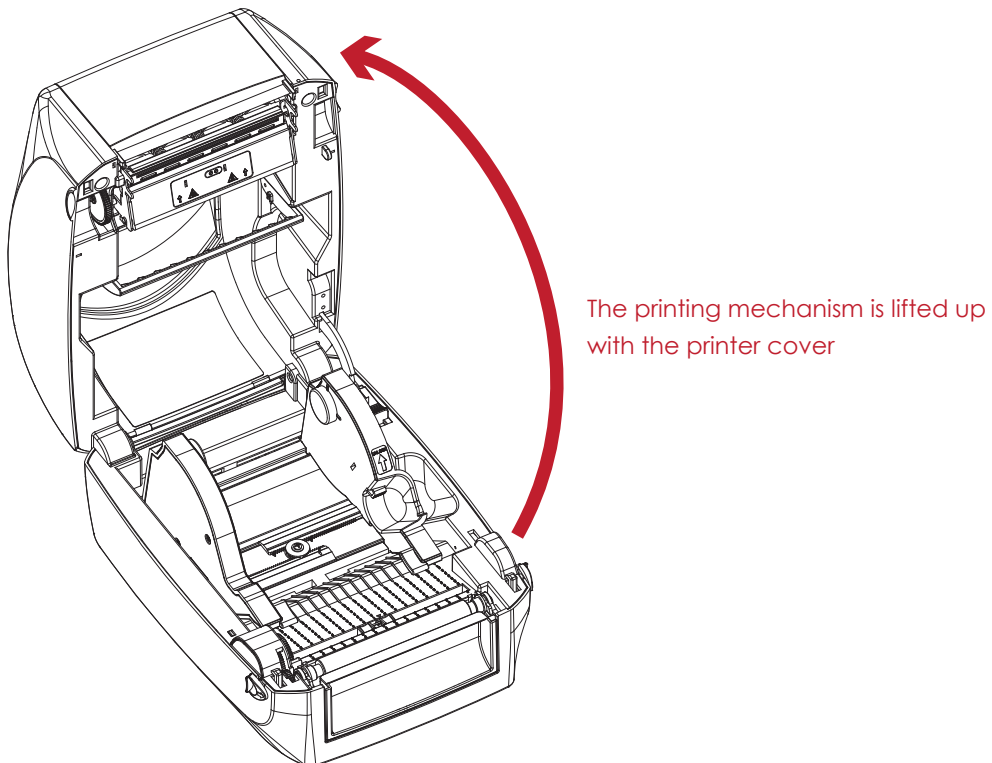

2 Printer Setup

2.2 Loading the Ribbon

A New Ribbon Module Installation



1. Attach the ribbon to the empty ribbon core with the adhesive strip at the end of the ribbon.

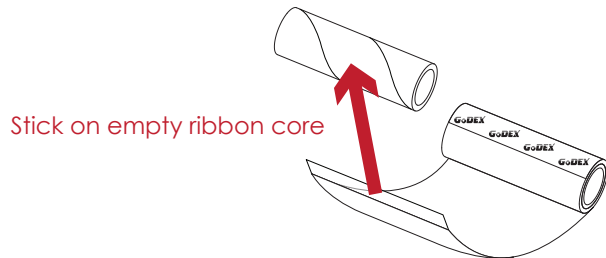

2. Insert the ribbon hub into empty ribbon core and new ribbon. Wind the ribbon around the empty ribbon core for 2 to 3 circles.

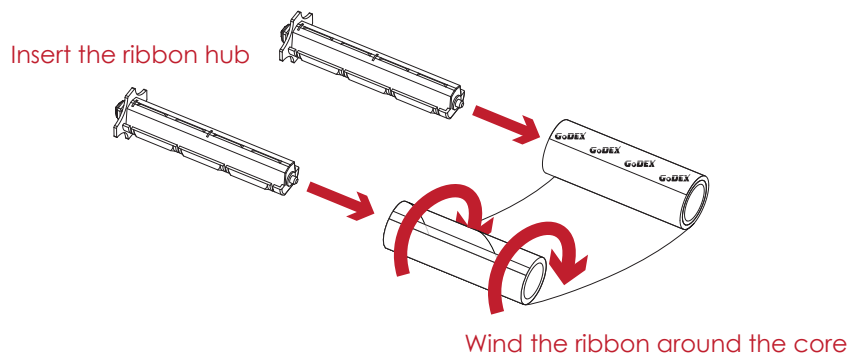

3. A ribbon module is assembled as below.

A NEW RIBBON MODULE

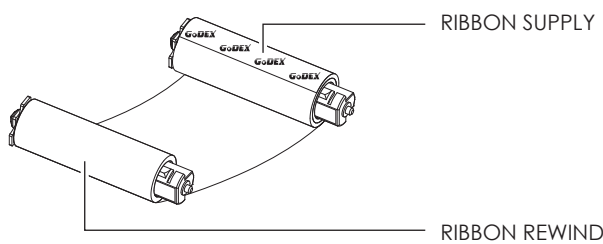

2 Printer Setup

Load the Ribbon on the Printer For Ribbon Supply Module

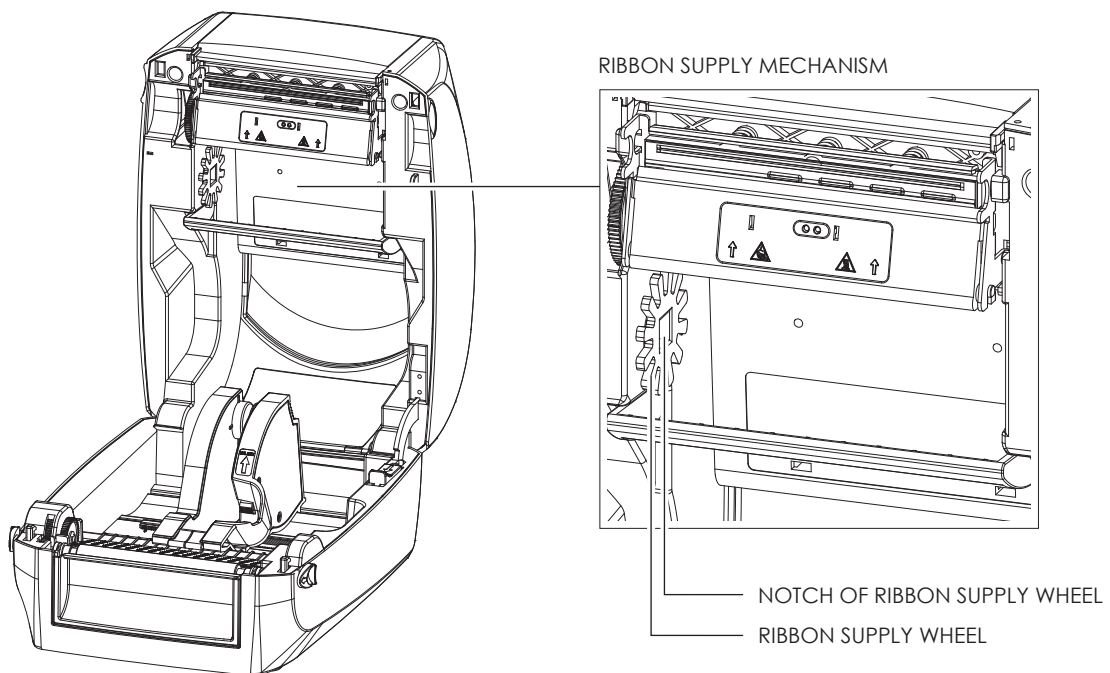

1. Place the ribbon supply module into the printing mechanism. Please the left-hand side of ribbon hub first. Make sure the holder of ribbon hub is inserted into the notch. Then place the right-hand side of ribbon hub.

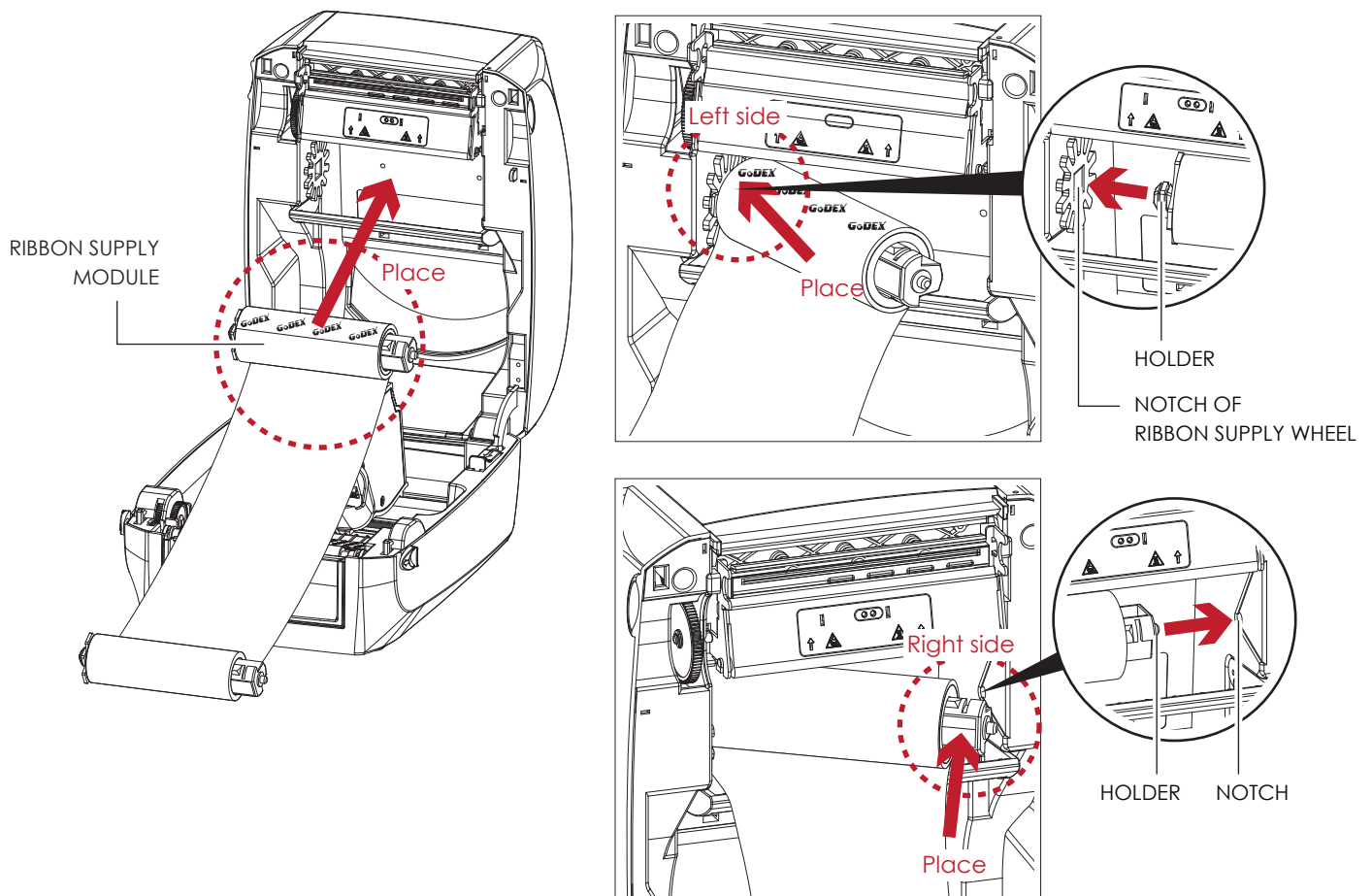

2 Printer Setup

2. Unlock the release catch to close the printer cover. Push the release catch forward to unlock it. The ribbon supply module loading is completed.

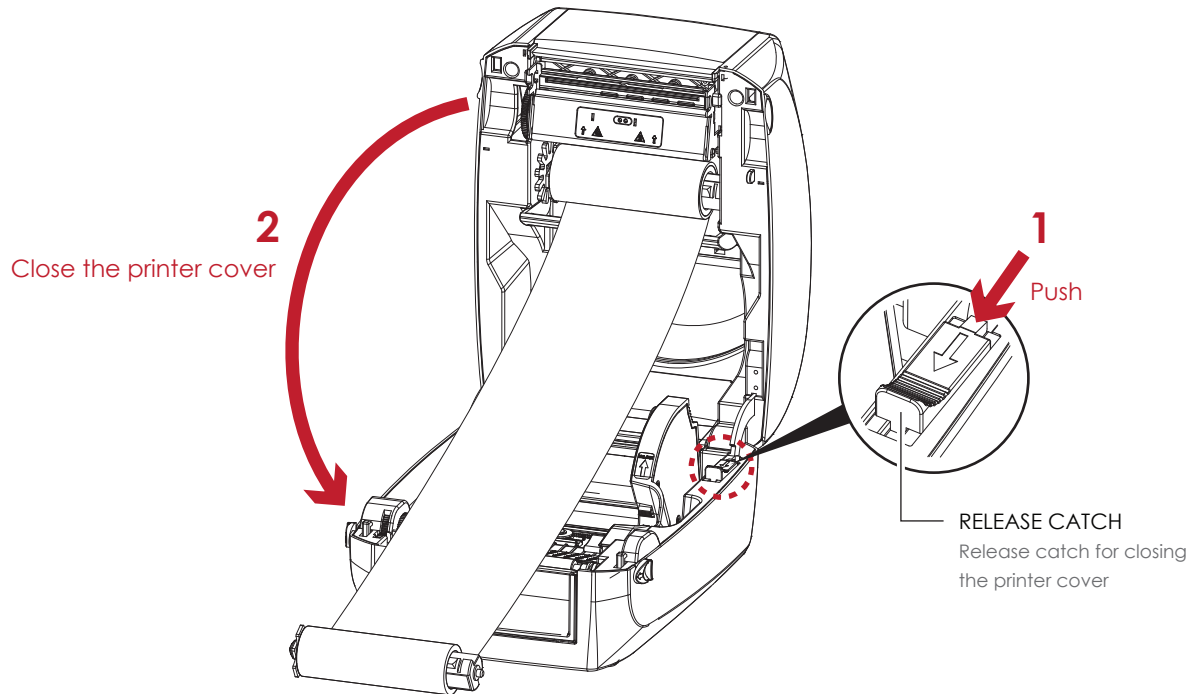

Load the Ribbon on the Printer For Ribbon Rewind Module

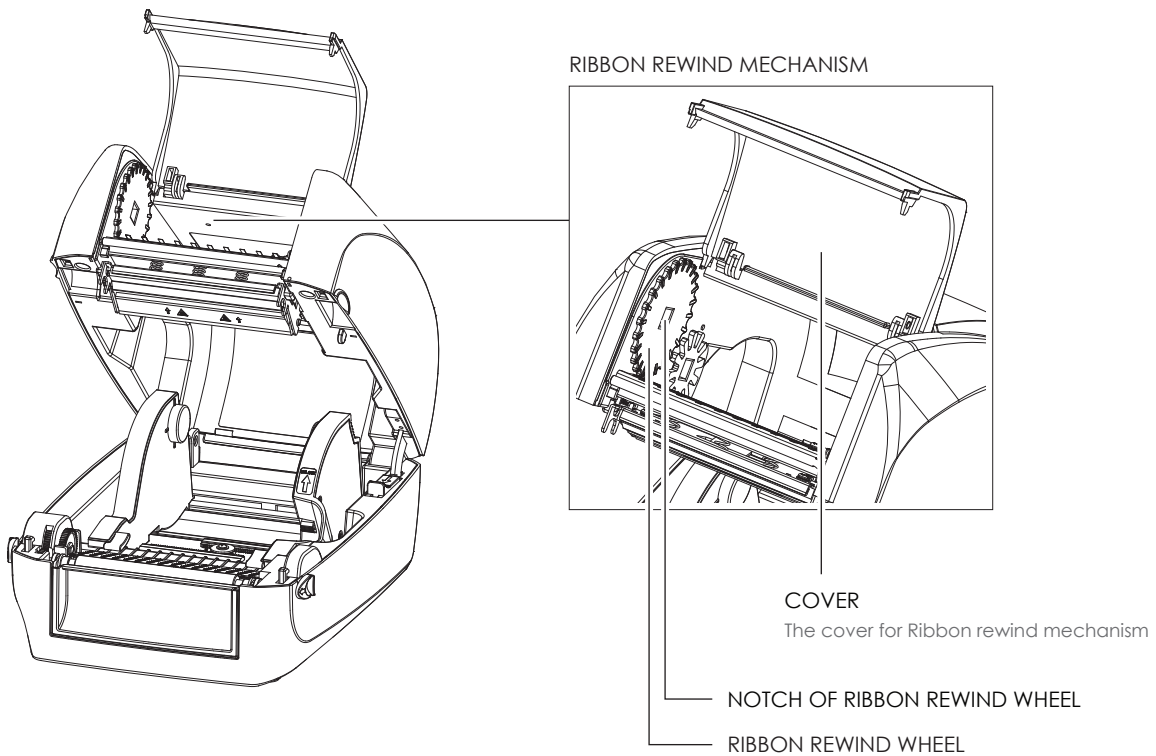

2 Printer Setup

1. Open the cover of ribbon rewind mechanism.

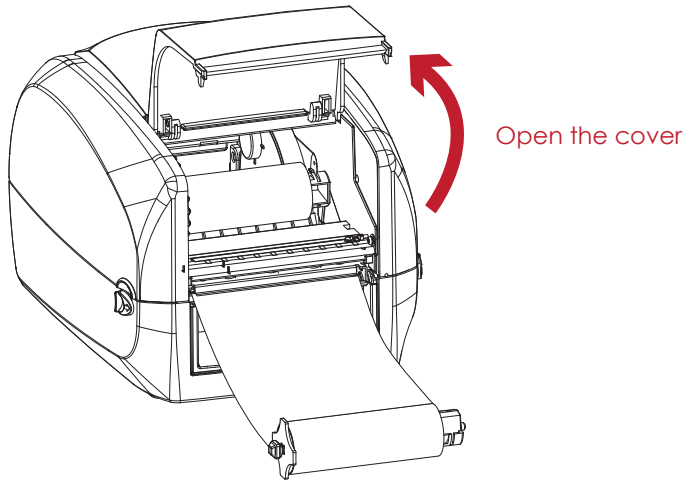

2. Place the ribbon rewind module into the ribbon rewind mechanism.
Please place the left-hand side of ribbon hub first. Make sure the holder of ribbon hub is inserted into the notch. Then place the right-hand side of ribbon hub.

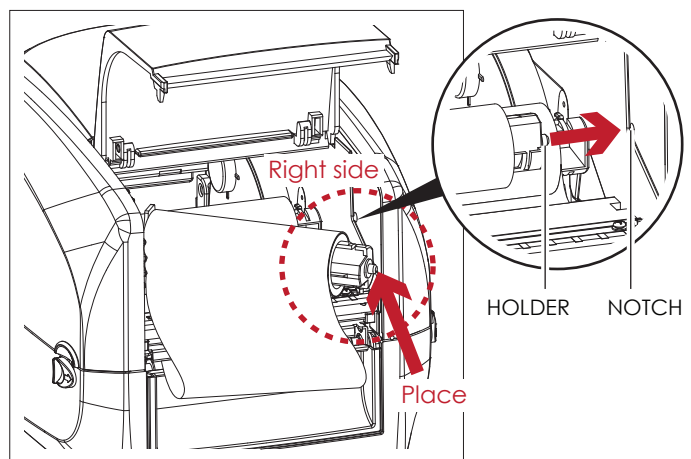
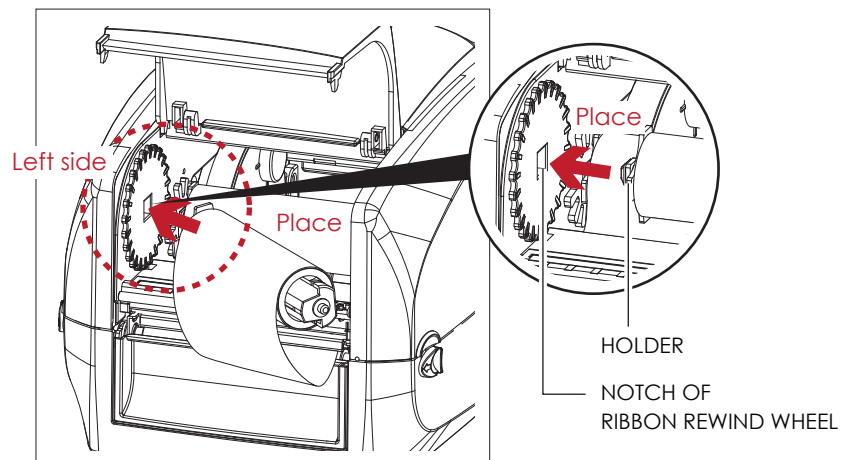
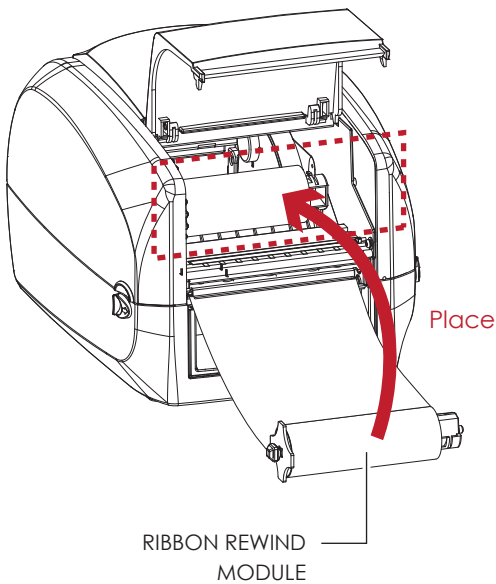

2 Printer Setup

3. Turn the ribbon rewind wheel to tighten the ribbon until it has no wrinkles.

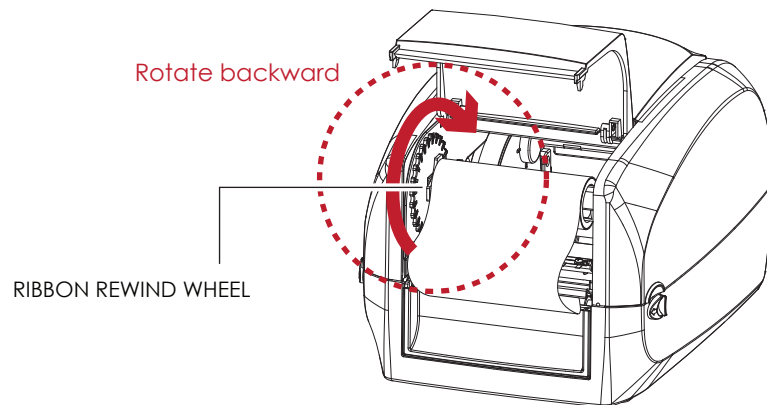

4. Close the cover of ribbon rewind mechanism.
The ribbon loading is completed once the ribbon supply module and ribbon rewind module are assembled correctly.

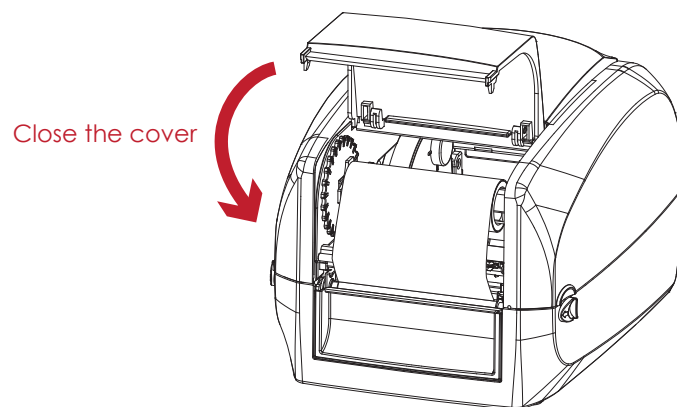

2 Printer Setup

2.3 Loading the Label Roll Module

Loading the Label Stock on the Printer

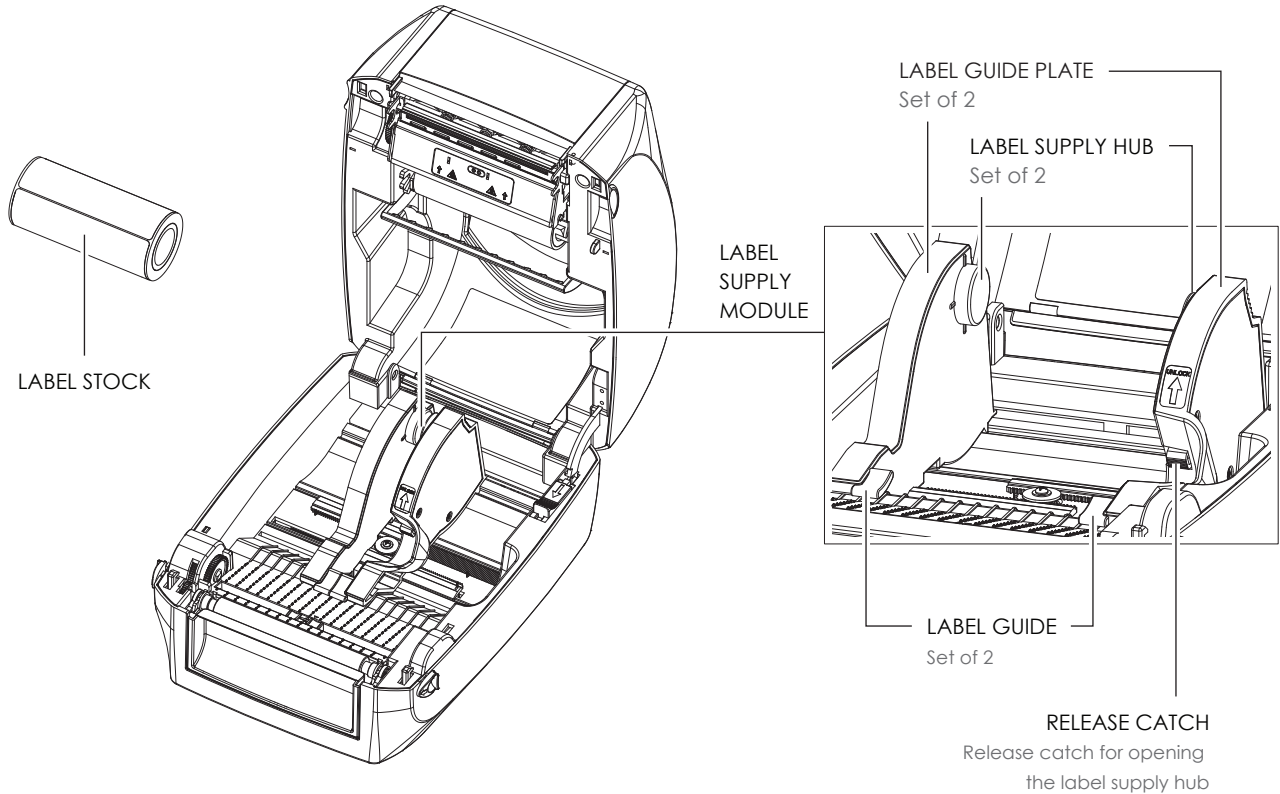

1. Unlock the ribbon catch and pull to open the label guide plate.

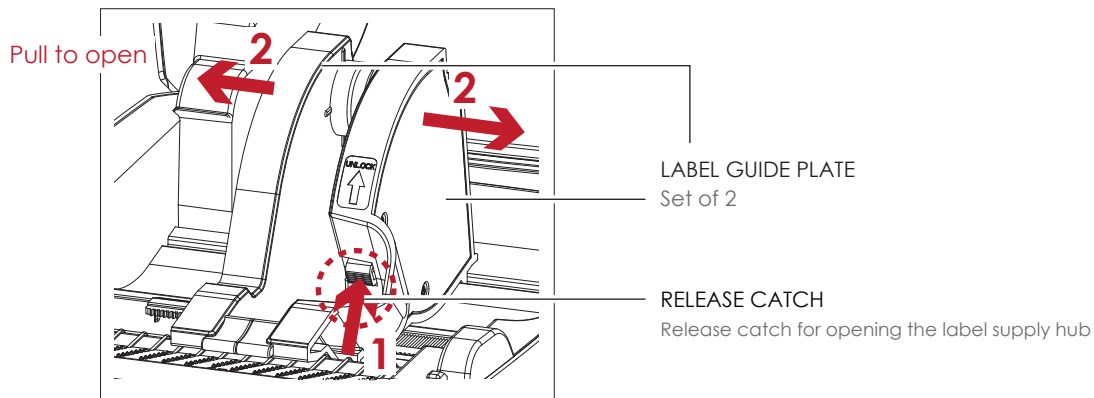

2. Place the label stock on label supply hubs. Make sure the label stock is aligned to both hubs. Adjust the label guide plates to fix the label width. Remember to push the release catch when moving the label guide plates.

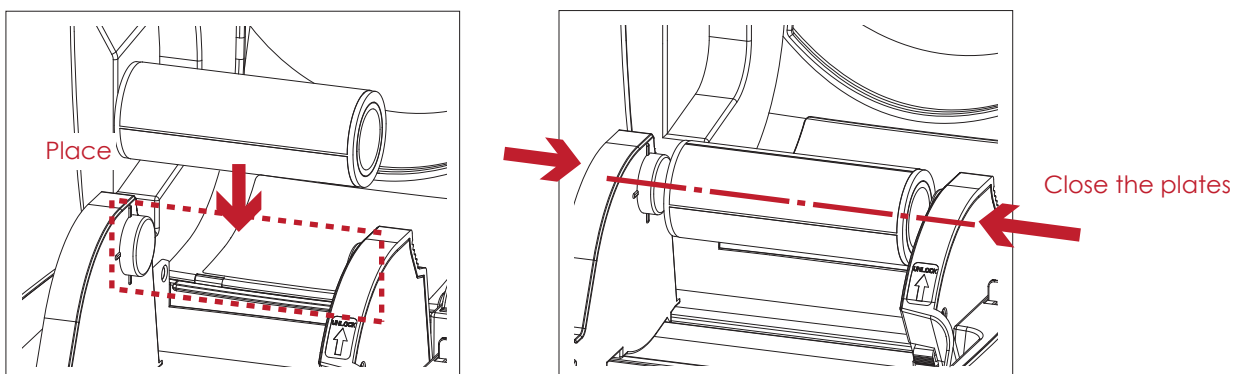

2 Printer Setup

3. Feed the Label through the label guides. The label guides will help to prevent the label swaying.

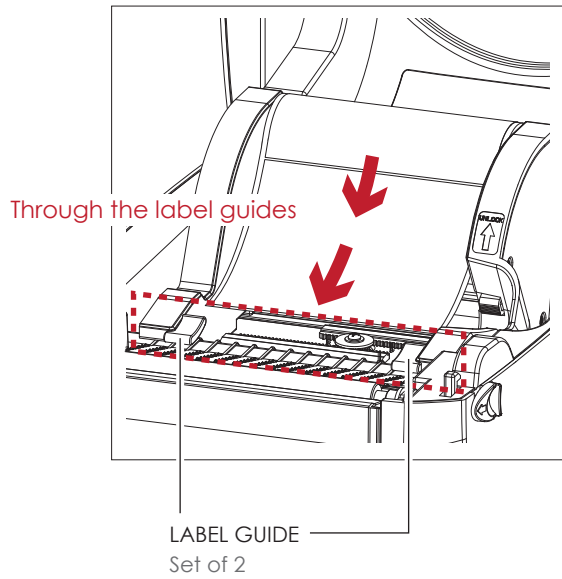

4. Unlock the release catch to close the printer cover.

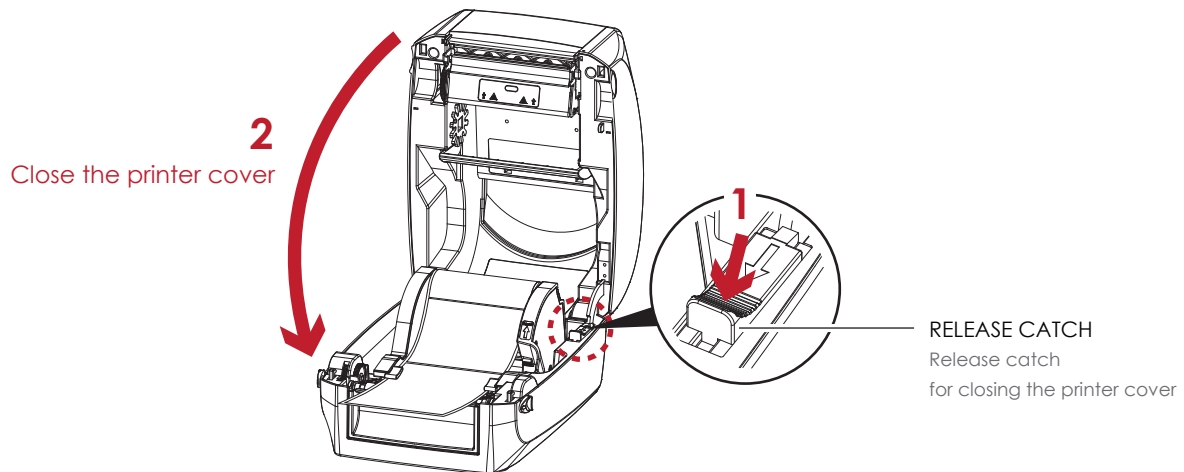

5. Press the FEED key and make sure the label is fed smoothly. The label loading is completed now.

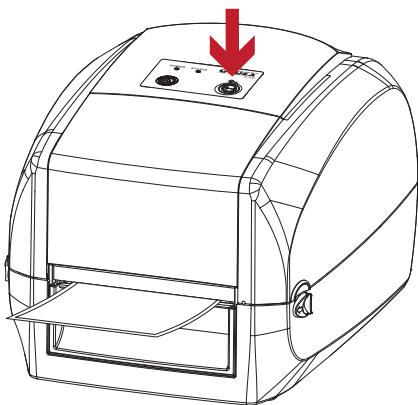

Notice

- * Please keeps the rack gear clean to ensure the smoothness of label holder.

2 Printer Setup

2.4 Connecting the Printer to the Host Computer

1. Please make sure that the printer is switched off.
2. Connect the power cord to the AC adapter.

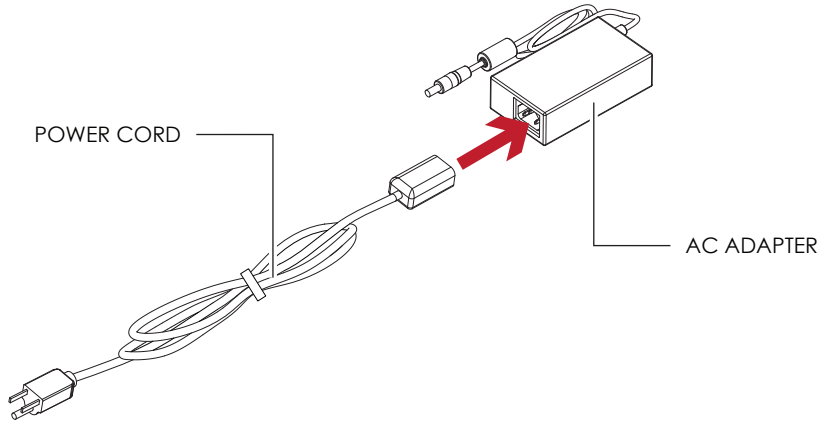

Connect the jack of the power adapter to the printer and connect the plug of the power adapter to the socket of the wall.

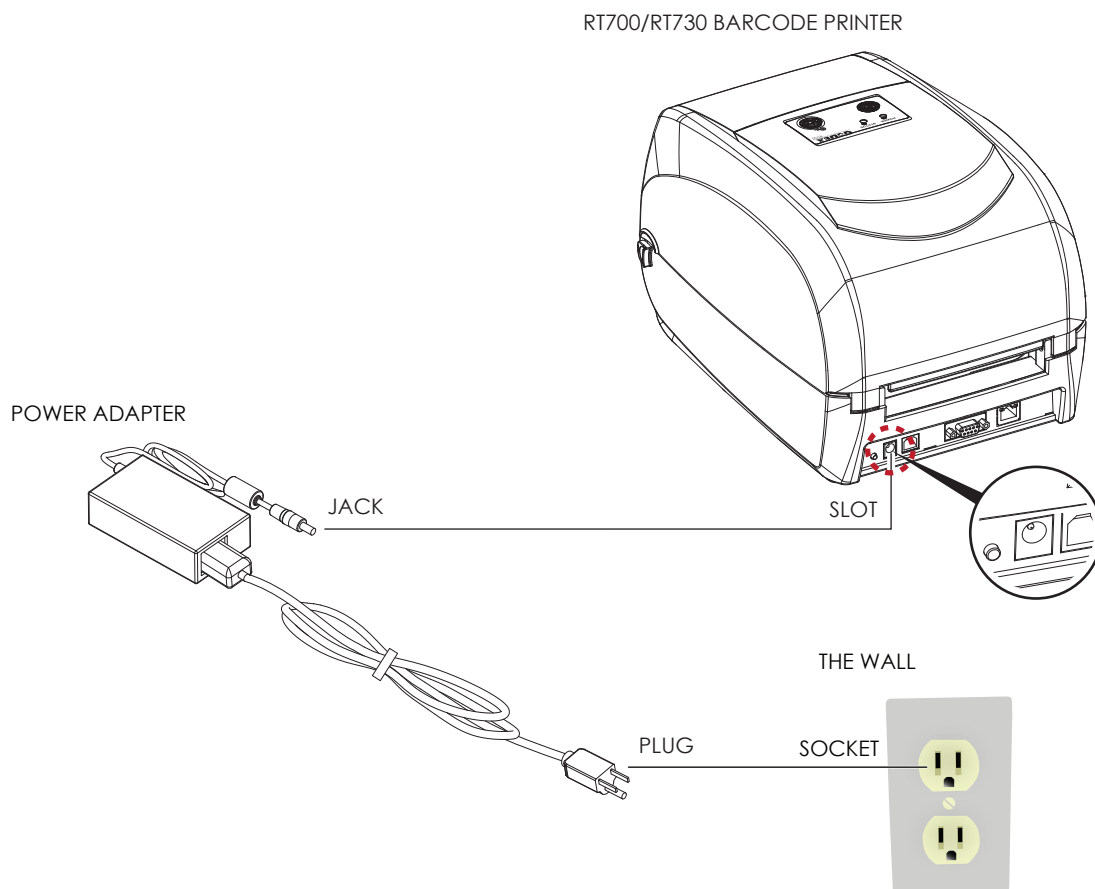

2 Printer Setup

3. Connect the USB/serial cable to the printer and host computer.

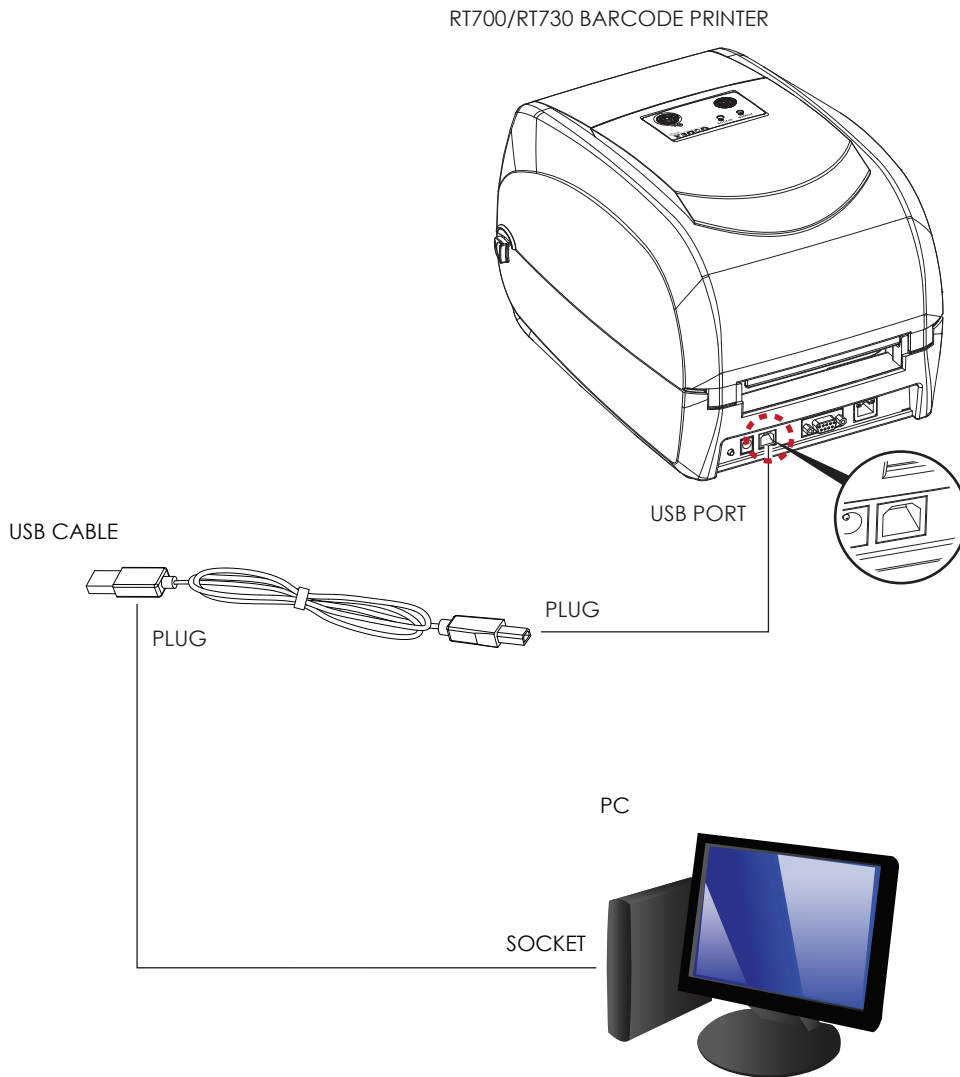

4. Pressing the power button. The power LED indicator should now lights up.

Pressing the power button

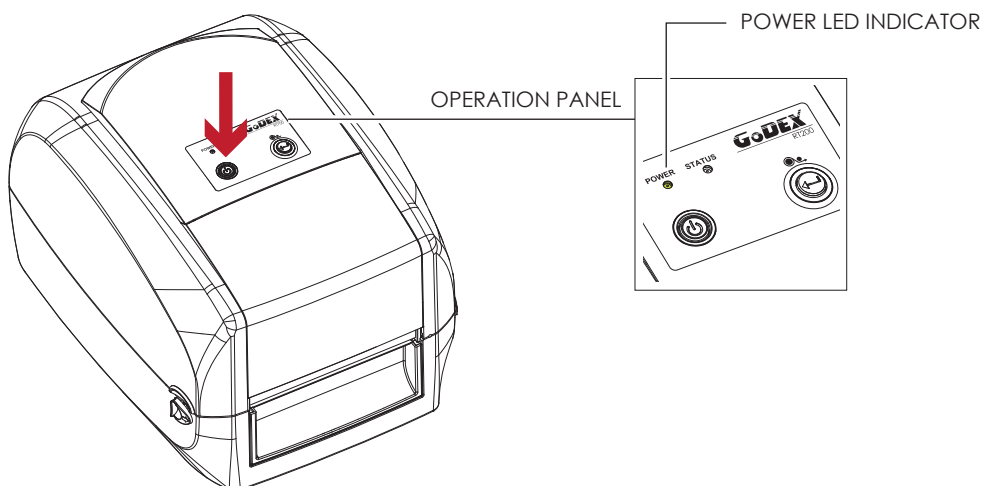

2 Printer Setup

2.5 Installing Printer Driver and GoLabel with Super Wizard CD

1. Insert the Super Wizard CD in the CD/DVD drive of the host computer and the program should pop up automatically.

You will see the Welcome screen first. On the Welcome screen, choose "Standard Installation".

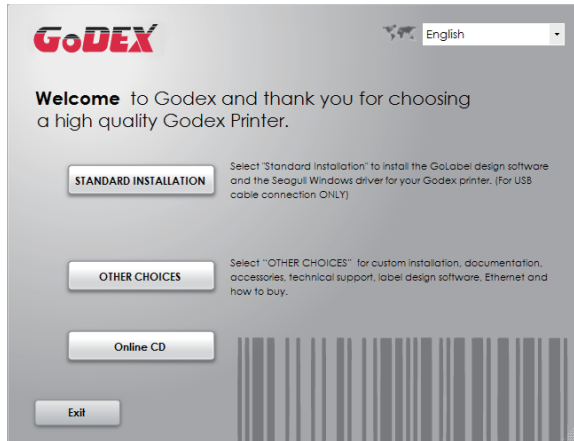

2. The wizard will then ask you to make sure your USB and power cables are connected and that the power is turned on. Make sure that is done and then click "Next".



3. The next screen you will see is, "Install the GoLabel Software and Windows driver". Click "Next" to continue.



Notice

- * If the Super Wizard program did not run automatically, you can either turn on the "Auto-run" setting for your CD/DVD driver or double-click the icon of CD/DVD driver to run the program.

2 Printer Setup

4. As the printer driver and GoLabel are installing, a screen will display a progress bar.



5. Once the installation is complete, you can start to make and print labels with GoLabel or through the printer driver.



6. As the optional steps, you can also print a test label or register your printer during the "Standard Installation" procedure.

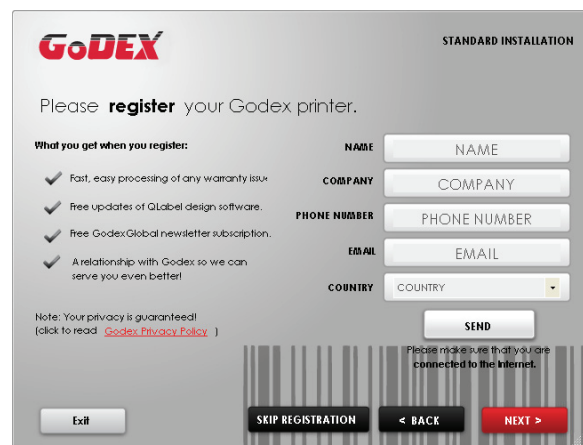

Notice

- * If you need more resources, tools or reference documents, you can also find them on Super Wizard CD. Just click "Other Choices" on Welcome Screen to access the files.

2 Printer Setup

Installing Printer Driver Directly from CD Folder

1. Insert the product CD in the CD/DVD drive of the host computer and open the "Seagull Drivers" folder on the CD. Select the icon for the driver file and click it to start the installation.

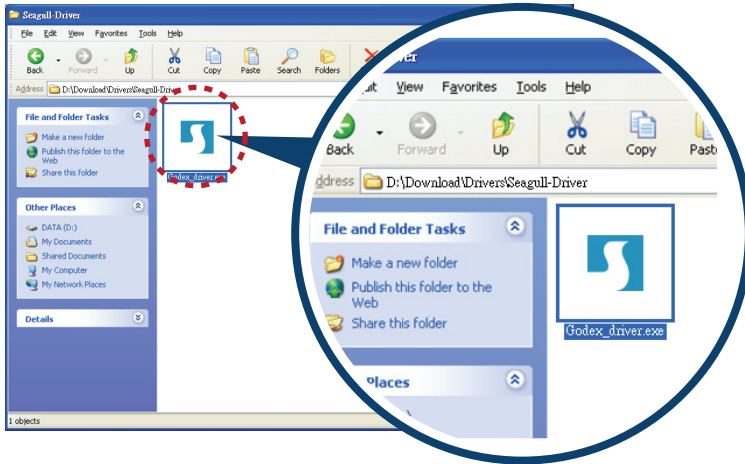

2. Follow the instructions on the screen. The Driver Wizard guides you through the installation procedure. Select "Install printer drivers".



3. Specify your printer model.

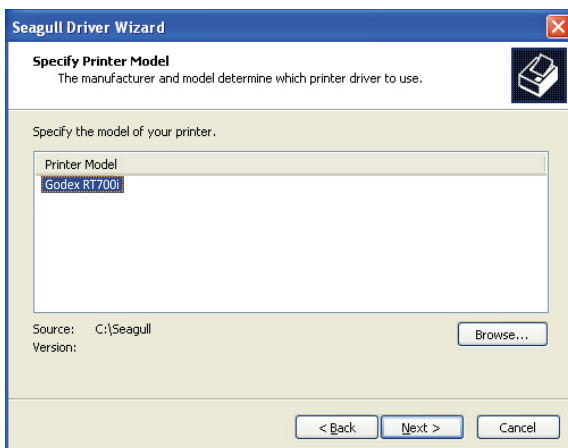

2 Printer Setup

- Specify the port used to connect the printer to the host computer.

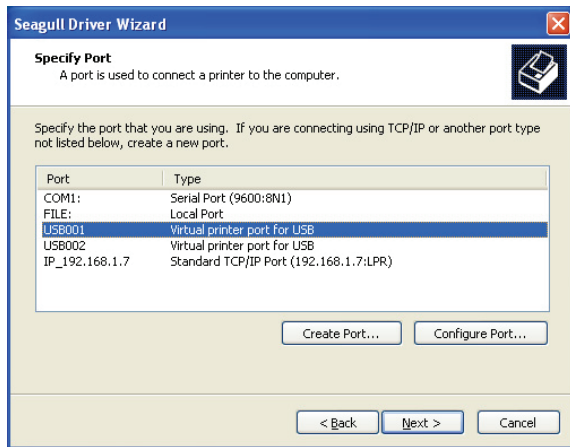

- Enter a printer name and assign the appropriate rights.

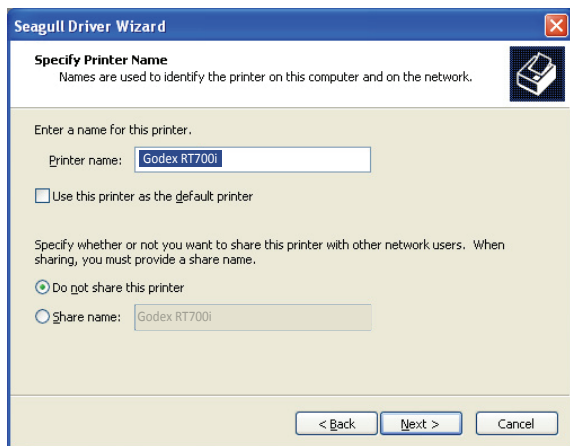

- Once the installation is complete, a summary of the printer settings is displayed. Check whether the printer settings are correct and click "Finish" to start copying the driver files. Wait until copying is complete, then finish the installation.

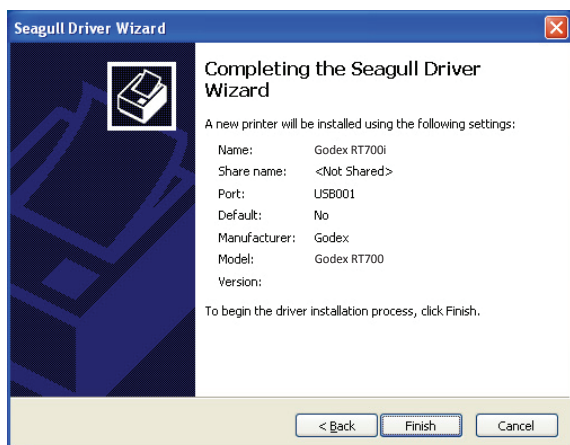

2 Printer Setup

7. Once the driver installation is complete, the new printer should appear in the "Printers and Faxes" folder.

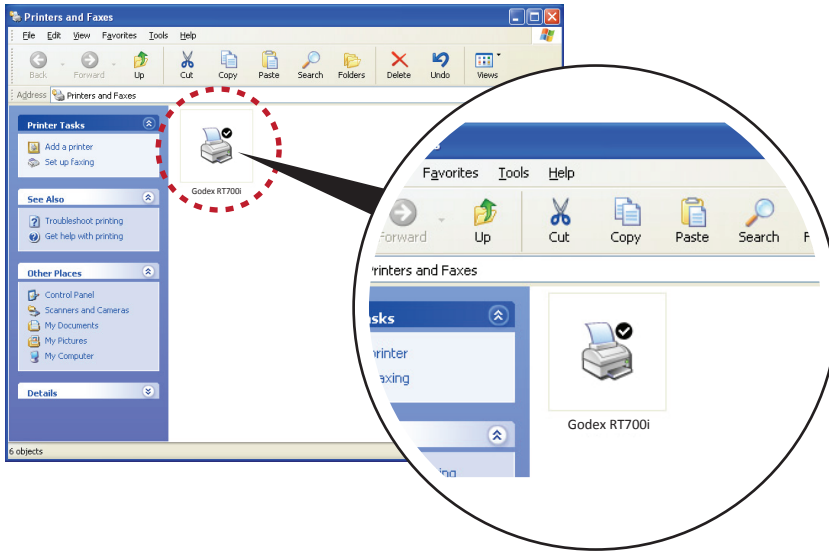

3 Printer Setting and Control

3.1 Operation Panel

Operation Panel Introduction

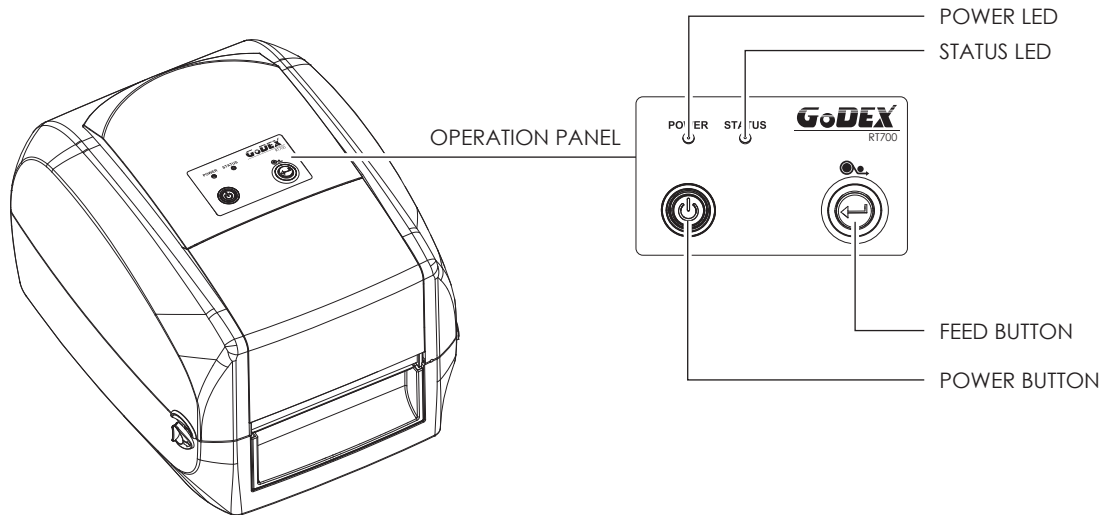

POWER Button

Press the POWER button and the LED indicator lights up green. The printer is on " Ready to print " status now. When printer is turned on, keep pressing the POWER button until the LED indicator lights off will turn the printer off.

FEED Button

When you press the FEED button, the printer moves the label to the defined stop position.

If you are using continuous labels, pressing the FEED button will move label stock until you release the button again.

If you are using individual labels, pressing the FEED button will move only one label.

If the label does not stop at the correct position, you need to run the auto-detection function on the label stock, please see Section 3.2 Label Calibration and Self Test.

LED Indicators

LED Indicator	Status	Description
Green	Standby	The printer is ready for operation.
Red	Error	The printer has detected an error. See Section 3.3 Error Alerts.

3 Printer Setting and Control

3.2 Label Calibration and Self Test

Label Calibration

The printer can automatically detect and store label height.

That means the host computer does not need to transmit the label height to the printer.

Self Test

Self-test function lets you check whether the printer is functioning normally.

Here is how you run the label size calibration and self test.

1. Check that the label stock is loaded correctly.
2. Turn off the printer.
3. Turn the printer on again, keeping the FEED button pressed. When the LED starts to flash red, release the FEED button. The printer will now measure the label stock and store the label height.
4. Once the printer has successfully measured the label stock, it will print a self-test label.

The contents of a self-test printout are listed below.

Model & Version	RT700:GX.XXX
USB ID setting	USB S/N:12345678
Serial port setting	Serial port:96,N,8,1
MAC address of Ethernet port	MAC Addr:xx-xx-xx-xx-xx-xx
IP protocol setting	DHCP Enable
IP address of Ethernet port	IP xxx.xxx.xxx.xxx
Gateway setting	Gateway xxx.xxx.xxx.xxx
Netmask setting	Sub-Mask xxx.xxx.xxx.xxx
	#####
Number of DRAM installed	1 DRAM installed
Image buffer size	Image buffer size:1500 KB
Number of forms	0000 FORM(S) IN MEMORY
Number of graphics	0000 GRAPHIC(S) IN MEMORY
Number of fonts	000 FONT(S) IN MEMORY
Number of Asian fonts	000 ASIAN FONT(S) IN MEMORY
Number of Databases	000 DATABASE(S) IN MEMORY
Number of Scalable fonts	000 TTF(S) IN MEMORY
Free memory size	4073 KB FREE MEMORY
Speed, Density, Ref. Point, Print direction	^S4 ^H8 ^R000 ~R200
Label width, Form length, Stop position	^W102 ^Q100,3 ^E18
Cutter, Label Dispenser, Mode	Option:^D0 ^O0 ^AD
Sensor Setting	Reflective AD:1.96 2.84 2.49[0.88_23]
Code Page	Code Page:850

3 Printer Setting and Control

Label Calibration Button

Keep pressing calibration button for 1 second, the printer can immediately run the label size calibration.

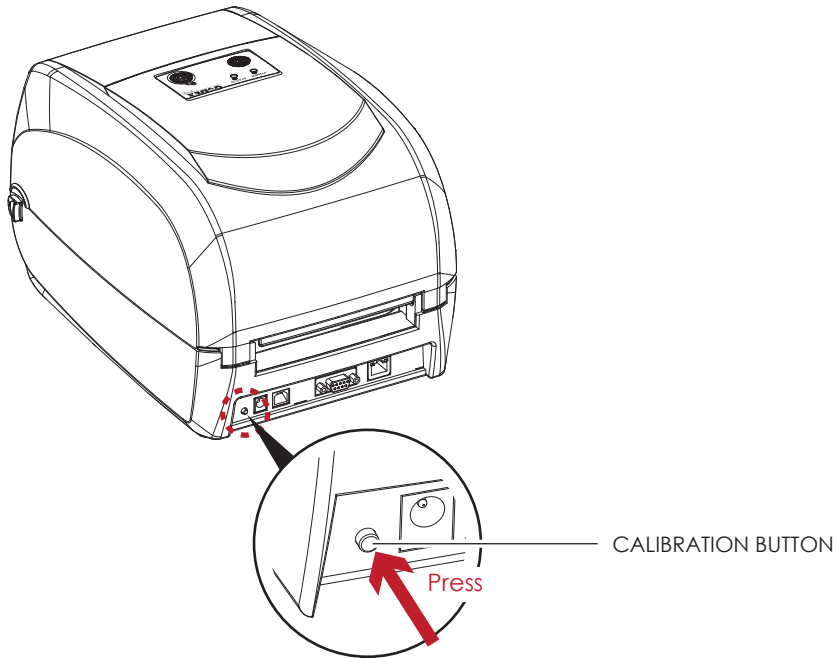

Calibration button can be used to find correct printing position or eliminate the "Media Error" problem.

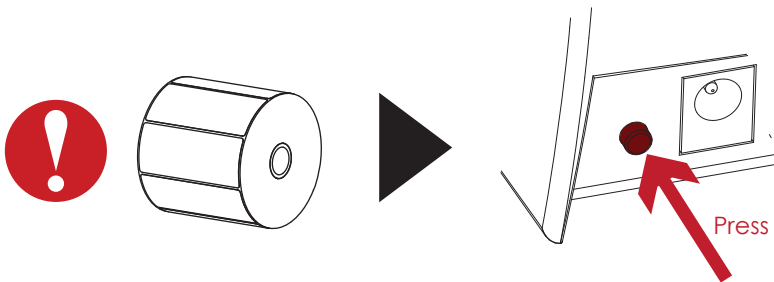

3 Printer Setting and Control

3.3 Error Alerts



In the event of a problem that prevents normal functioning of the printer, you will see an error message on LED indicators and hear some beep signals. Please refer to below table for the error alerts.

Error Light





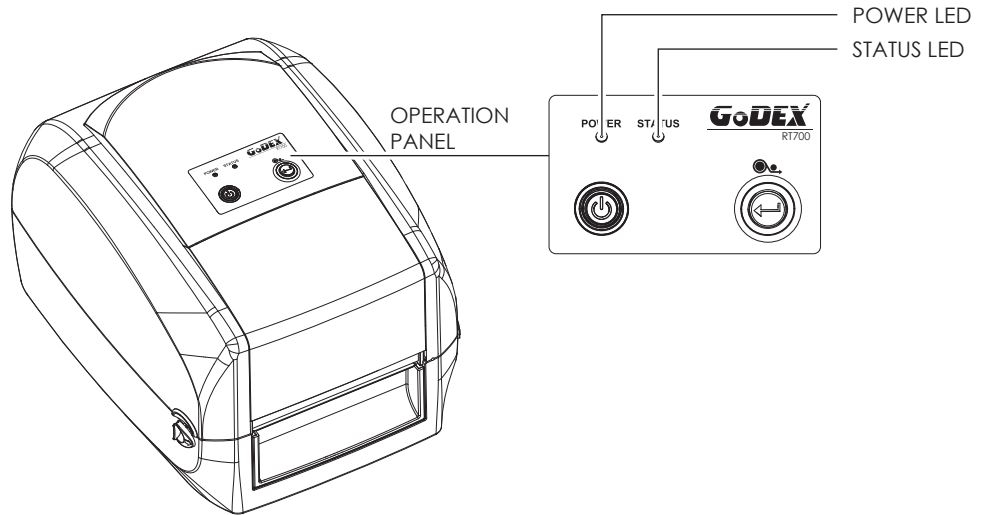

Colour

- Red 

Flashing Frequency

- Flashing 
- Light On 



LED Indicator		Type	Beeps	Description	Solution
POWER LED	STATUS LED				
		Print Head Error	2 x 4 beeps	The printing mechanism is not correctly closed.	Open the print mechanism and close it again.
		Print Head Error	None	High temperature at the print head.	Once the print head has cooled down, the printer switches to standby mode.
		Media Error	2 x 3 beeps	No ribbon is installed and the printer displays an error.	Make sure that the printer is set to direct thermal printing mode.
				The ribbon is finished or the label supply hub is not moving.	Replace the ribbon roll.
		Media Error	2 x 2 beeps	No paper is detected.	Make sure that the label sensor is positioned correctly. If the sensor still does not detect the paper, run the auto-detection function again.
				Paper is finished.	Replace the label roll.
				Printer feed problem.	Possible reasons: the print medium has become trapped around the rubber roll; the sensor cannot detect a gap or black mark between the labels; there is no paper. Please reset the sensor.
		File Error	2 x 2 beeps	The memory is full. The printer prints the message "File System full".	Delete unnecessary data or install additional memory.
				Unable to find file. The printer prints the message "File Name Not Found".	Use the "~X4" command to print all files. Then check whether the files exist and whether the names are correct.
				A file of the same name already exists. The printer prints the message "Duplicate Name".	Change the name of the file and try storing it again.

4 NetSetting for Ethernet

4.1 Installing the NetSetting software

The NetSetting software is used to manage the network configurations when connecting the printer via Ethernet port. It is available on product CD or can be downloaded from official website. To install the NetSetting, please follow below steps.

1. Insert the product CD in the CD/DVD drive of the host computer and open the "Ethernet" folder on the CD.
2. Select the icon for the NetSetting installation file and click it to start the installation.

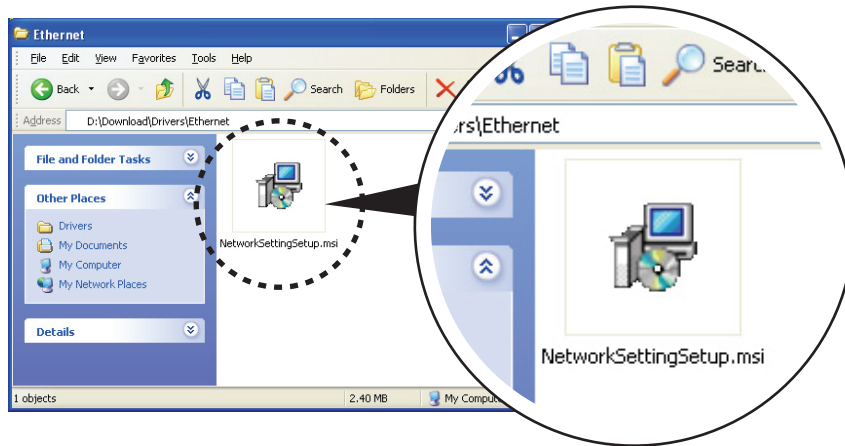

3. Follow the instructions on the screen. The Setup Wizard guides you through the installation procedure.
4. Specify the "Installation Folder".

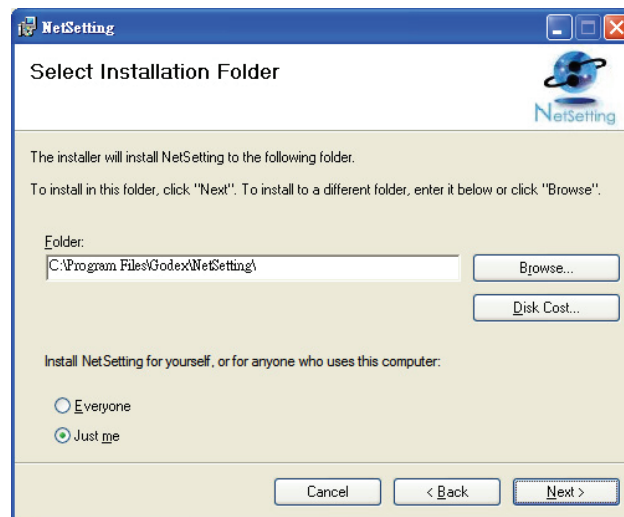

5. Click "Next" to start the installation.
6. Once the installation is completed; you will see the NetSetting icon on your desktop.



4 NetSetting for Ethernet

4.2 The Interface of NetSetting

Click the NetSetting icon to start the program; you will see the start page as below. The start page will display the basic information of connected printer and your PC.

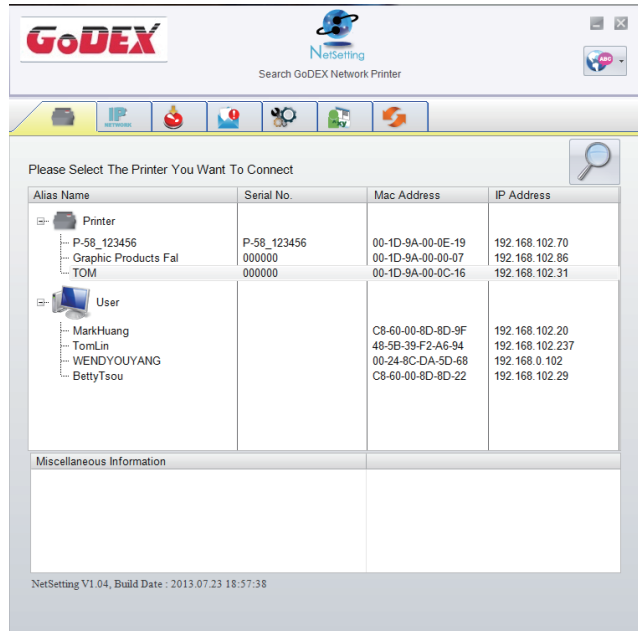

Click the magnifier icon to search the Godex printers which are connected via Ethernet port in your network environment. Once a connected Godex printer is detected, it will be listed on the start page.

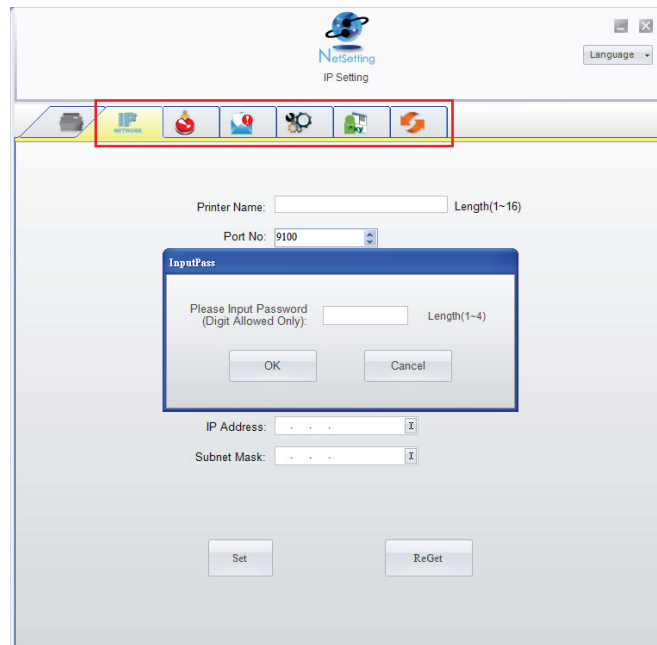

There are six tabs on the top of interface which can configure different types of network settings. But for the data security reason, you need correct password to enter the configuration pages.

Notice

* The default password is "1111", you can change the password later from the "IP Setting" tab.

4 NetSetting for Ethernet

IP Setting

The IP Setting tab can change the printer name, Port number, Gateway setting and the password for configuring the printer. You can also set the printer's IP address either by DHCP or by Static IP.

The screenshot shows the GoDEX NetSetting IP Setting interface. The header includes the GoDEX logo and the NetSetting IP Setting title. Below the header is a navigation bar with icons for printer, network, status, alert, settings, help, and refresh. The main content area contains the following fields and options:

- Printer Name: Godex (Length(1~16))
- Port No: 9100
- Default Gateway: 192 . 168 . 0 . 254
- Password: 1111 (Length(1~4))
- Radio buttons: Get IP From DHCP Server, Static IP
- IP Address: 192 . 168 . 102 . 55
- Subnet Mask: 255 . 255 . 255 . 0
- Buttons: Set, Refresh

You can press "Set" button to apply the settings and "ReGet" button to refresh the setting values.

Notice

* To fully benefit from the NetSetting software, you should be familiar with basic networking principles. Please contact your network administrator for related network setting information.

4 NetSetting for Ethernet

Alert Path Setting

NetSetting will send the alert messages to designated mail account when the error happened on printer. The alert messages are sent by SMTP (Simple Mail Transfer Protocol) or SNMP (Simple Network Management Protocol). You can set or change the configurations of SMTP and SNMP on this "Alert Path Setting" tab.

GoDEX NetSetting Alert Mail Setting

Enable SMTP Alert Message Notification

Login Account: default Length(1~64)
Login Password: ***** Length(1~16)
Server IP Address: 192 . 168 . 0 . 1 xxx.xxx.xxx.xxx
Mail Subject: Barcode printer message Length(1~60)
Mail From Address: default@default.com Length(1~32)
Mail To Address: default@default.com Length(1~32)
Duration Cycle: 1 0 ~ 168 Hours
Event Counter: 5 1 ~ 100

Enable SNMP Alert Message Notification

SNMP Community: public Length(1~16)
SNMP Trap Community: public Length(1~16)
Trap IP Address: 192 . 168 . 0 . 1 xxx.xxx.xxx.xxx

Set Refresh

You can press "Set" button to apply the settings and "ReGet" button to refresh the setting values.

4 NetSetting for Ethernet

Alert Message Setting

For the alert message notification function, you can decide which error cases need to be sent out to the operator. Moreover, the alert messages can be set to be sent by SMTP, SNMP or both.



You can press "Set" button to apply the settings and "ReGet" button to refresh the setting values.

4 NetSetting for Ethernet

Printer Configuration

Set or change the configurations of connected printer. Most of key settings for the printer operation can be done by this setting page.

The screenshot shows the GoDEX NetSetting Printer Configuration web interface. The interface has a header with the GoDEX logo and the NetSetting logo. Below the header is a navigation bar with icons for printer, IP network, printer status, printer settings, printer driver, and printer refresh. The main content area is divided into three sections: Printer Setup, Serial Port Setting, and Miscellaneous. The Printer Setup section contains dropdown menus for Printer Model (RT700), Tear-off Position (12), Speed (2), Darkness (12), Dispenser/Applicator (0 (None)), Labels per Cut (0), and Printing Mode (Thermal Transfer). The Serial Port Setting section contains dropdown menus for Baud Rate (4800), Parity (None), Data Bits (8), and Stop Bits (1). The Miscellaneous section contains dropdown menus for LCD Language (Traditional Chinese), Sensing Mode (0 - Reflective), Keyboard Country Code (US), Pre-Printing (OFF), Code Page (Code Page 850), Top Of Form (ON), and Buzzer (ON). At the bottom of the interface are two buttons: Set and Refresh.

You can press "Set" button to apply the settings and "ReGet" button to refresh the setting values.

4 NetSetting for Ethernet

User Command

The "User Command" tab provides a communication interface for operator to control the printer. Input printer commands in "Input Command" window and press "Send Command" button, the commands will be sent to the printer.

For some commands that will return response message, the message will be displayed in "Output Message" window.



You can press "Send Command" button to send printer commands via Ethernet port and control the printer remotely.

4 NetSetting for Ethernet

Firmware Download

On “Firmware Download” tab, the current version of printer firmware will be showed on the screen. If you need to update the printer firmware, just specify the file location of firmware file and press “Start Download Firmware” button. The printer firmware then can be updated remotely.

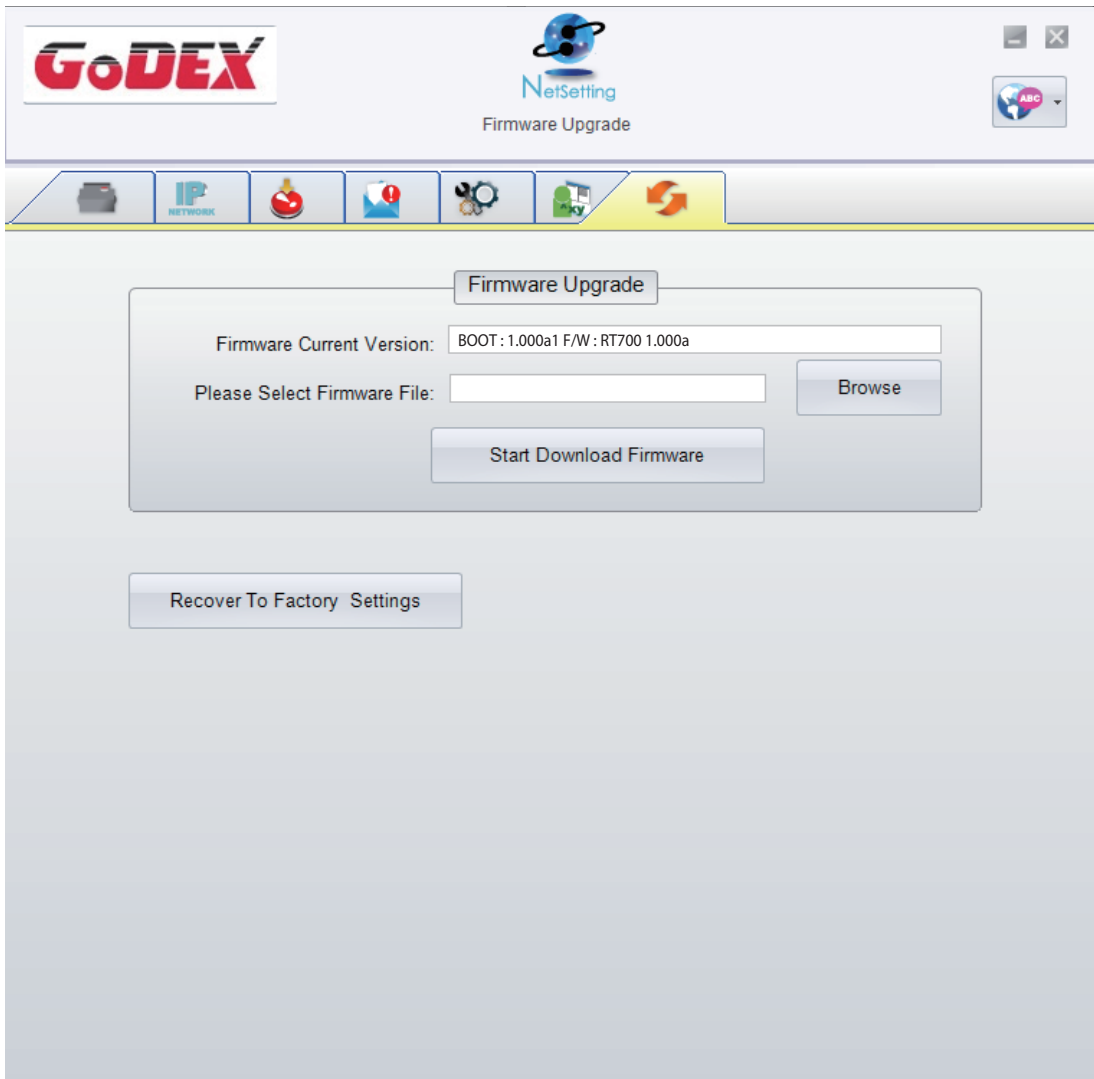

In addition to the firmware update, you can press “Recover To Factory Settings” button to restore the printer configurations back to factory default.

5 Accessories

5.1 Preparation Steps

Before installing the optional modules, please make some preparations as follows.

1. Turn off the printer :
Remember to switch off the printer before installing any module.
2. Open the printer cover and the printing mechanism :
Open the printer cover by pulling the release catches on both sides of the printer and lift the cover.
Please see the Section 2.1 for further information about Open the Printer.

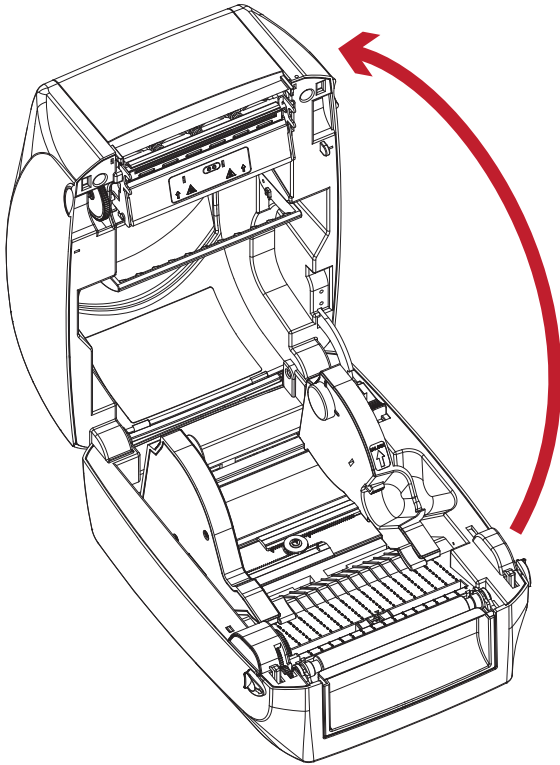

The printing mechanism is lifted up with the printer cover

3. Remove the front cover :
Please pull upward to remove the front cover.

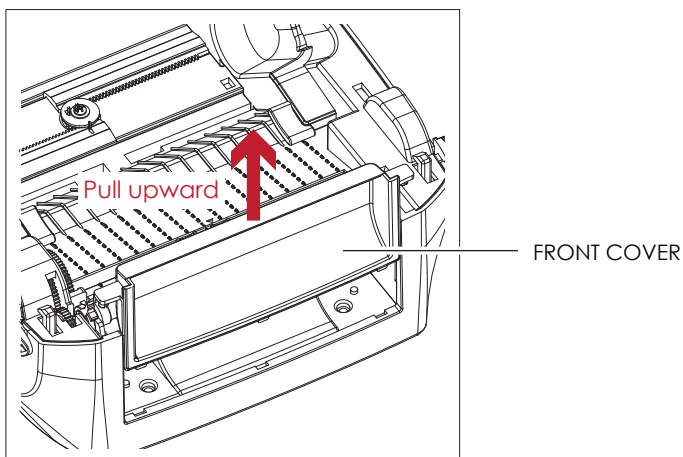

5 Accessories

4. Remove the platen :

Lift up the release clips on both sides of the platen to release and pull upward the platen.

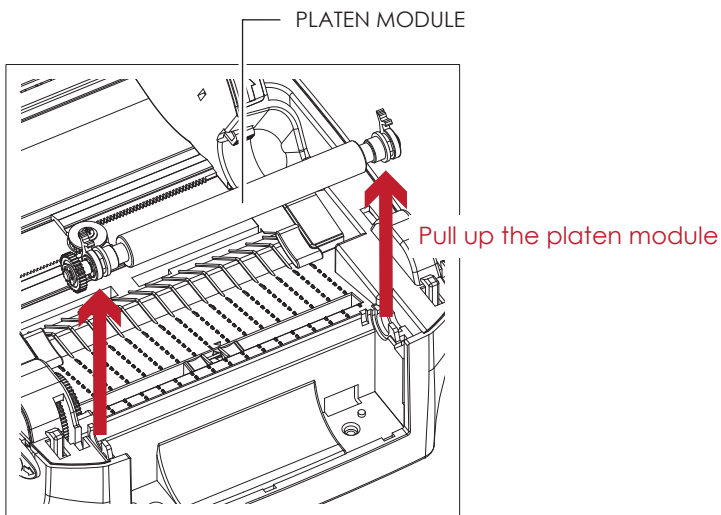
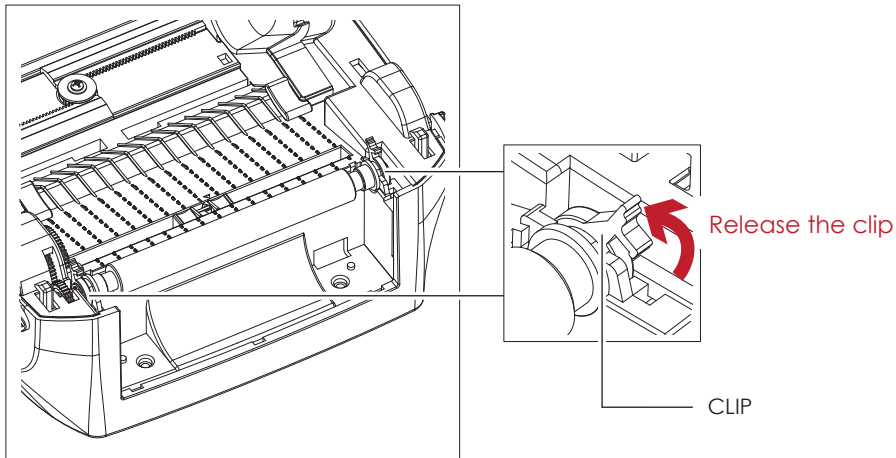

5. Ribbon loading :

Please see the Section 2.2 for further information about Loading the Ribbon.

6. Label loading

Please see the Section 2.3 for further information about Loading the Label Roll Module.

5 Accessories

5.2 Installing the Label Dispenser

The Overview of the Label Dispenser

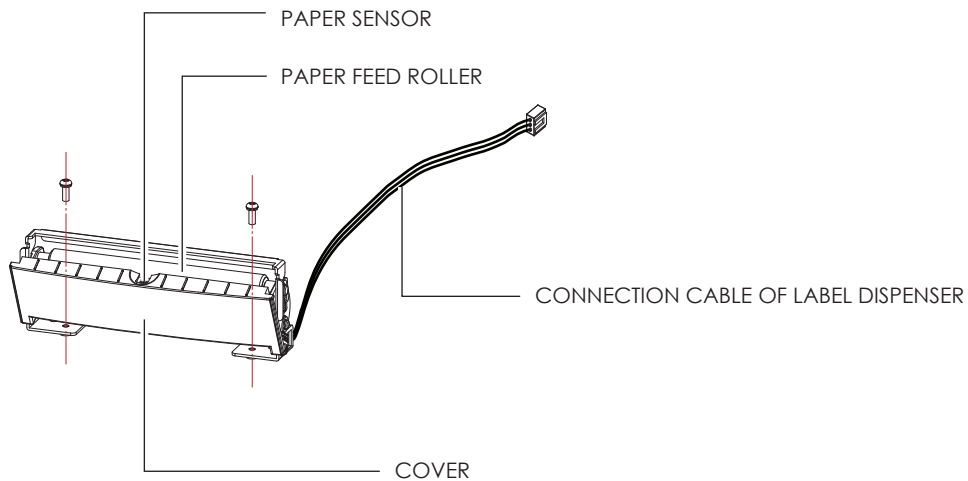

Preparation Steps

Please see the Section 5.1 Preparation Steps to complete the preparation steps before installing the label dispenser.

Installing the Label Dispenser

1. Pass the connection cable through the slot of the printer.

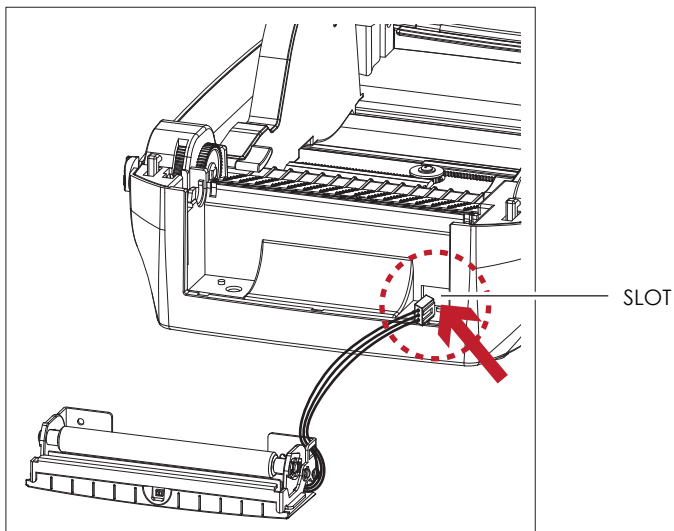

Notice

- * A label liner thickness of $0.006 \text{ mm} \pm 10\%$ and a weight of $65 \text{ g/m}^2 \pm 6\%$ are recommended.
- ** The label dispenser will take labels up to a max. width of 118 mm.
- *** When using the label dispenser, set the stop position (printer command ^E) to 13.

5 Accessories

2. Place label dispenser to align both holes of screw and then tighten the the screws.

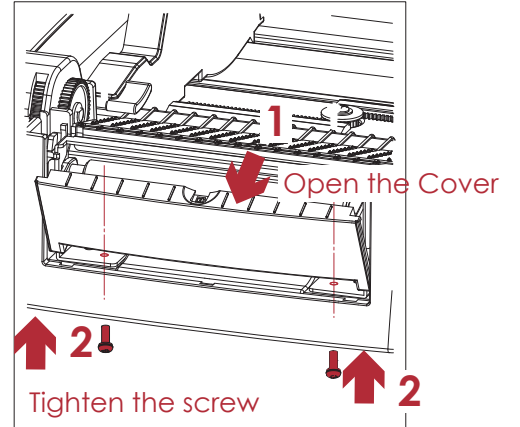
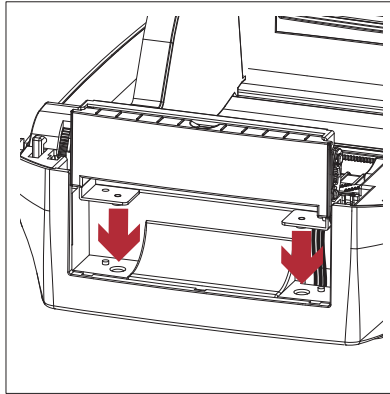
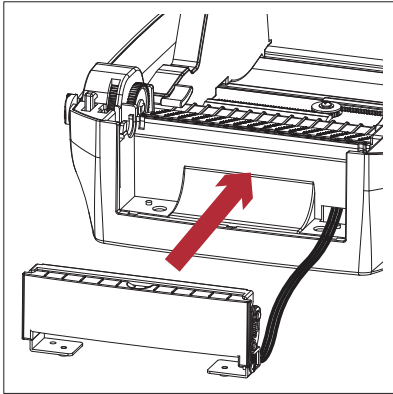

3. Place the platen back to the printer and lock the clips.

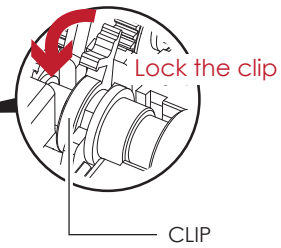
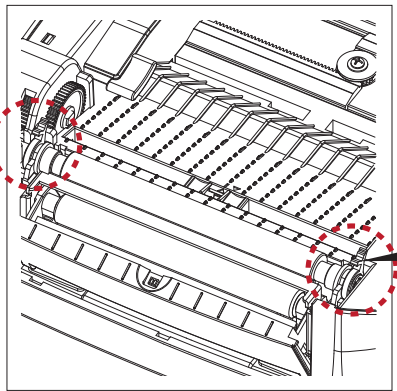
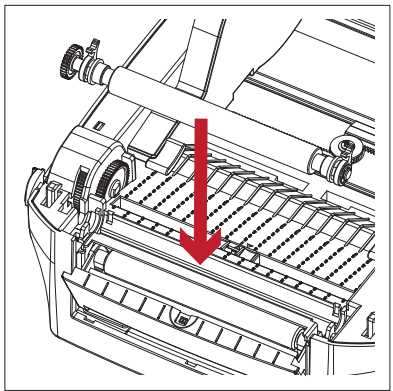

4. Close the printer cover and printing mechanism. Then to turn the printer upside down.

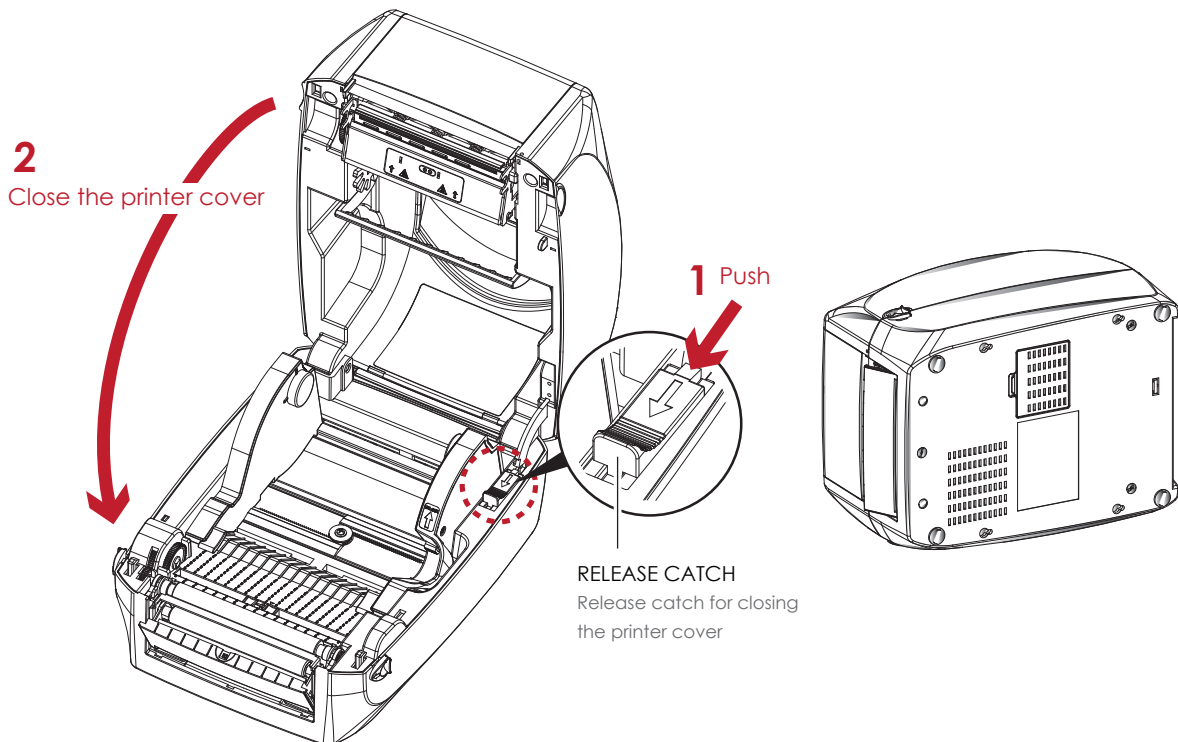

5 Accessories

5. Open the cover on the bottom of printer.

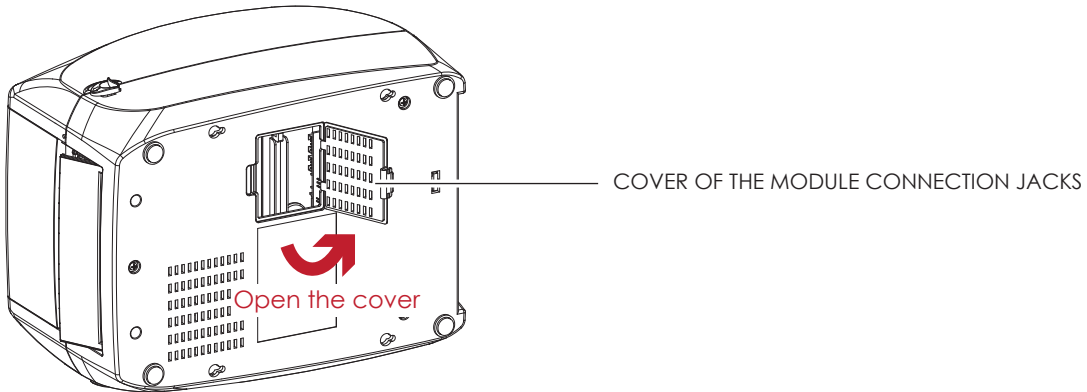

6. Plug the connector for the label dispenser to the jack.

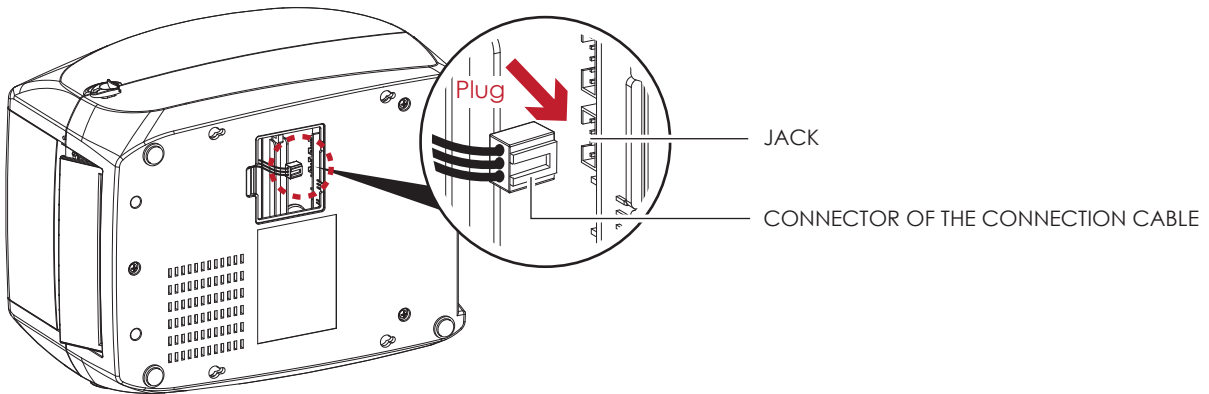

7. Close the cover of the module connection jacks.

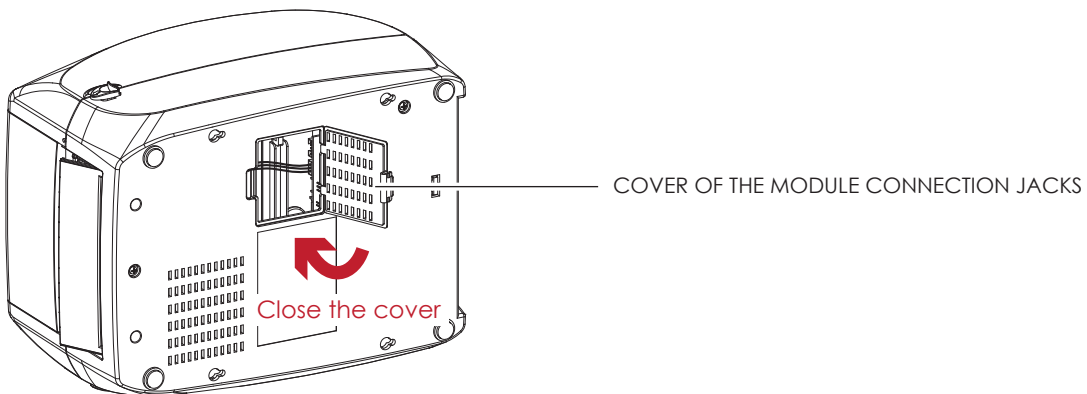

Notice

- * The printer must be switched off when plugging the connector, or the motherboard may be destroyed!
- ** There are 2 jacks : the lower jack for the label dispenser, the upper jack for the cutter.

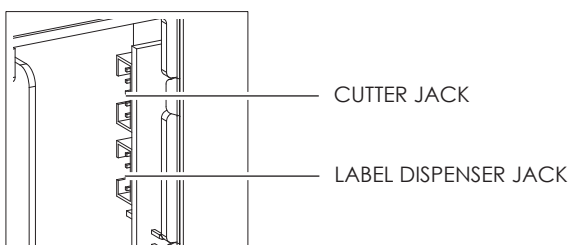

5 Accessories

Loading Label Roll with the Label Dispenser Module

1. Remove the first label from the label stock.

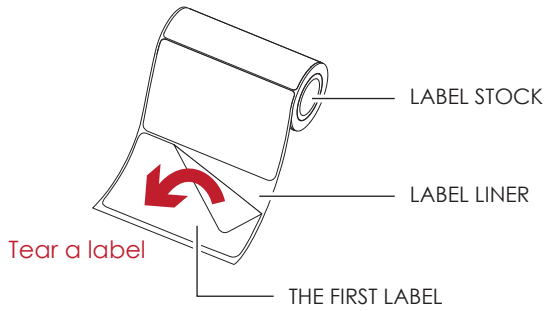

2. Feed the Label stock through the label guides.
And pull the label liner through the platen and the steel of the label dispenser.

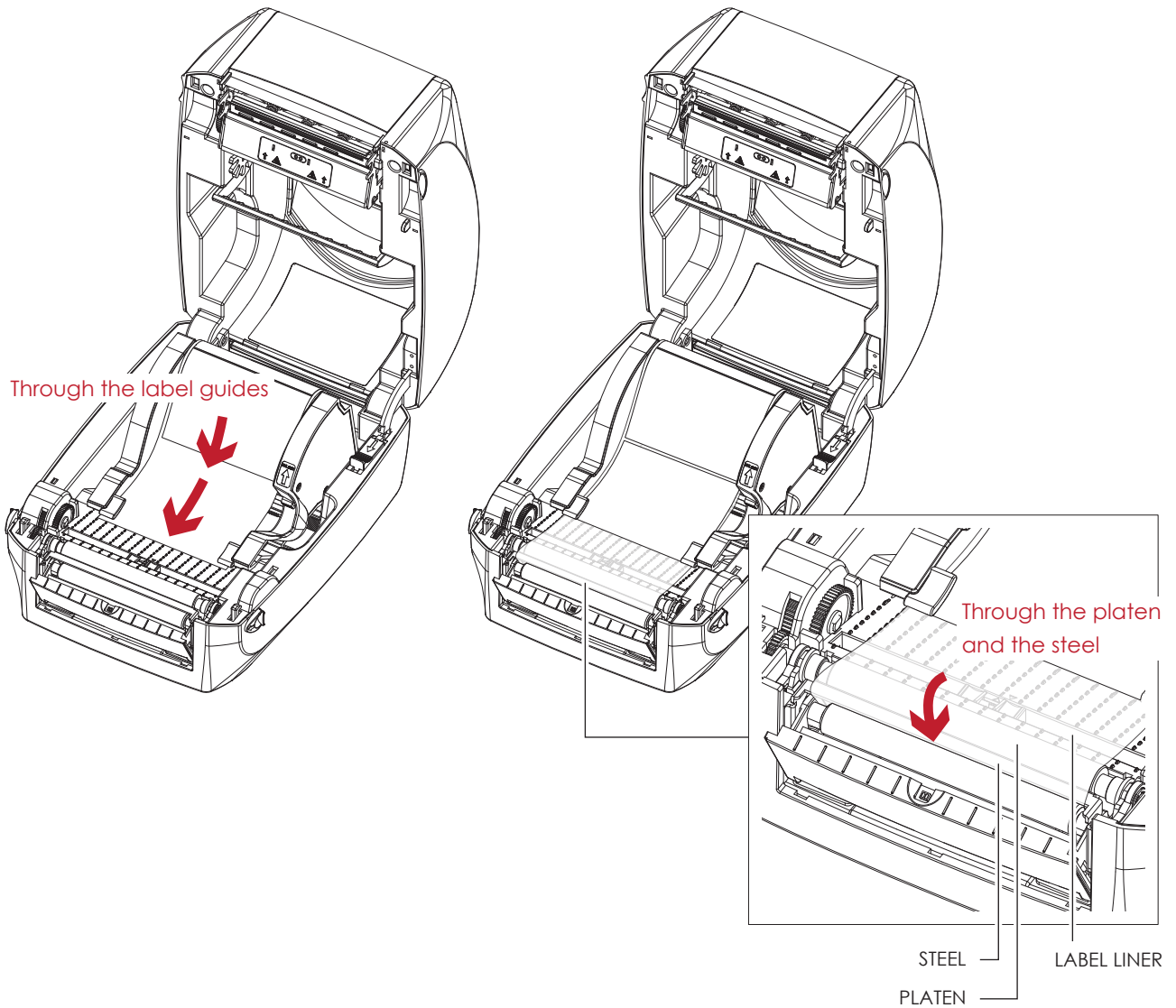

Notice

* Labels should be at least 25 mm high.

5 Accessories

3. The feeding path of label and liner should be as shown in below graphic.

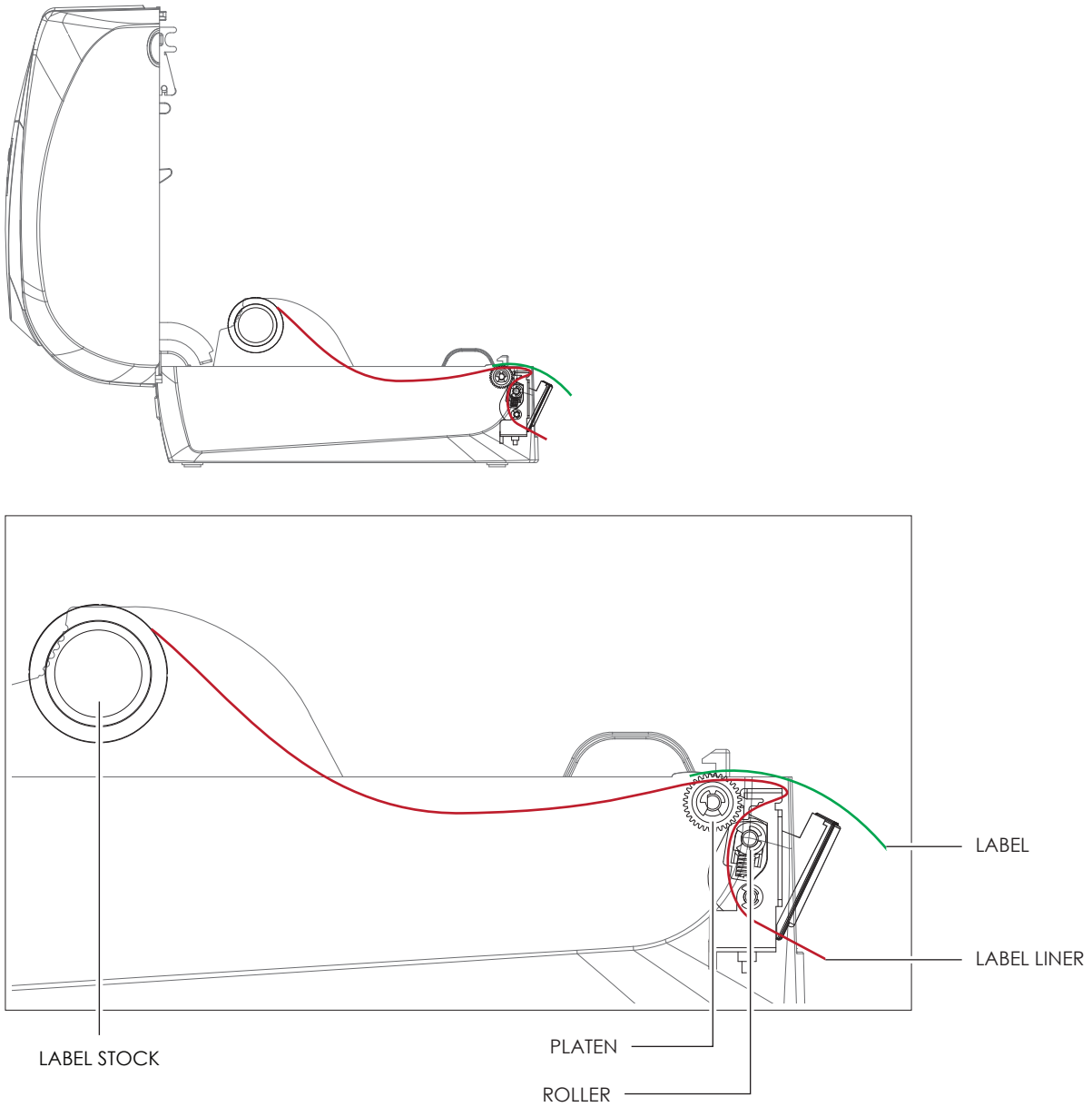

4. Close the label dispenser and printer cover. The installation is completed now.

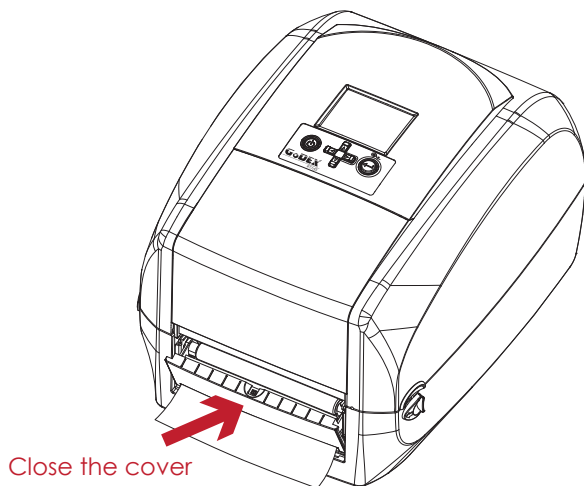

5 Accessories

5. Press the FEED button to feed the label. The label will be peeled from the liner while it passes through the label dispenser.

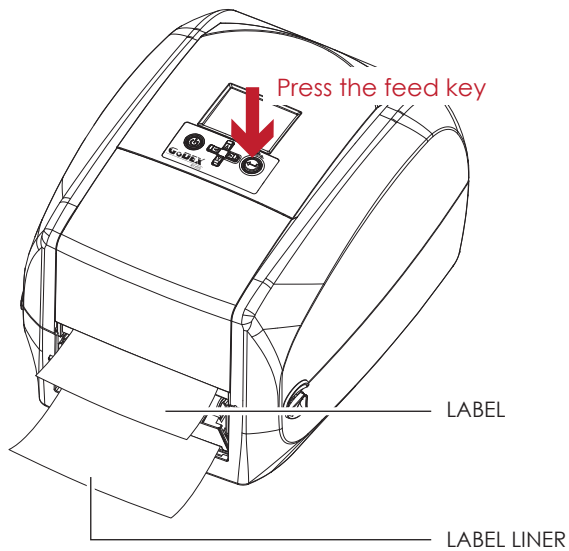

Notice

- * There is a paper sensor on the Label Dispenser module. It will stop the printing if it is covered by label. Remove the last printed label and the printer will then continue to print next label.

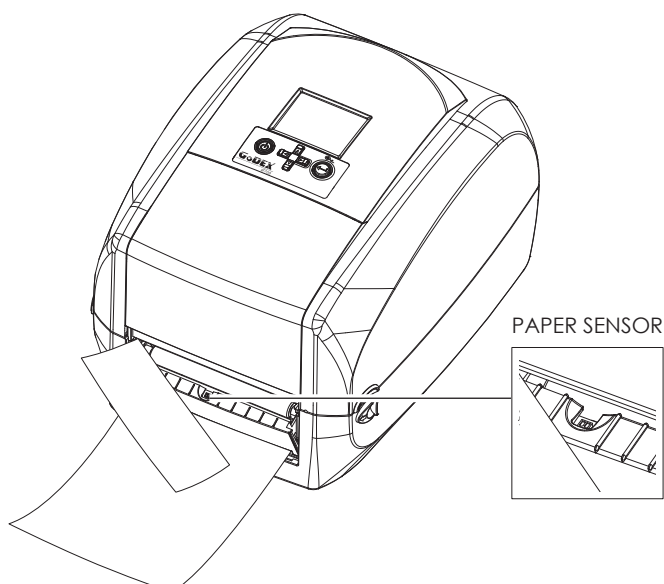

5 Accessories

5.3 Installing the Cutter

The Overview of the Cutter

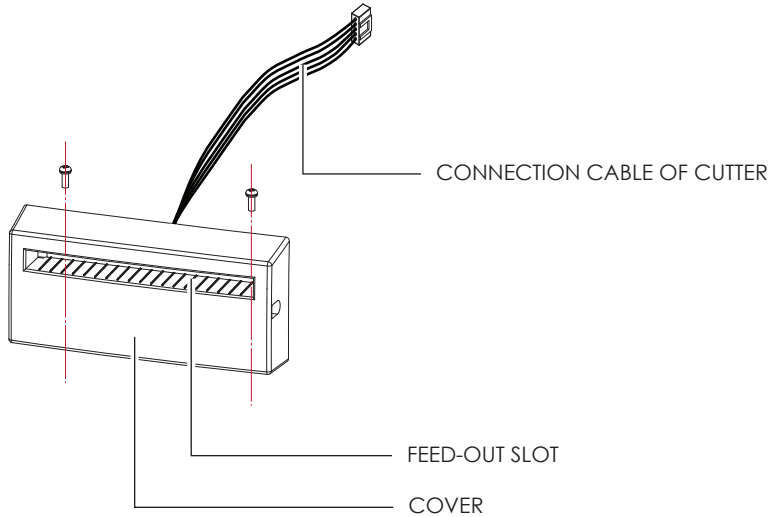

Preparation Steps

Please see the Section 5.1 Preparation Steps to complete the preparation steps before installing the cutter.

Installing the Cutter

1. Pass the connection cable through the slot of the printer.

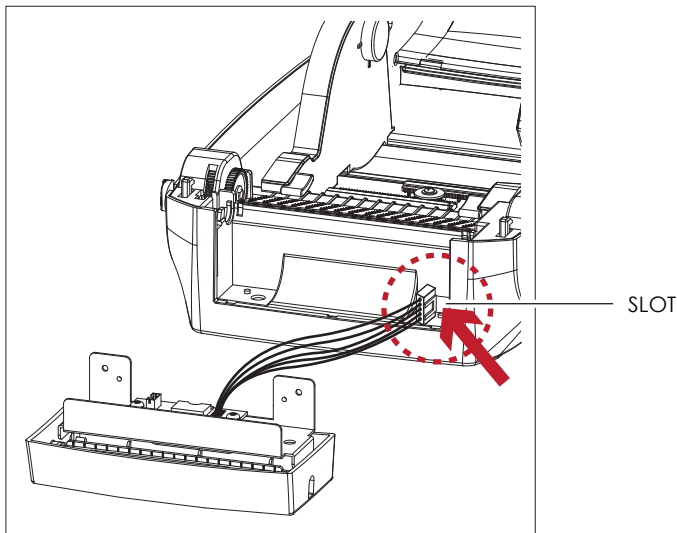

Notice

- * Remember to switch off the printer before installing the cutter.
- ** Do not use to cut adhesive labels! Glue residue will be left on the cutter blade and impair its functioning. The cutter has a blade life of 400,000 cuts when using paper liner which is 250 μ m thick and 3 inches wide.
- *** You can cut paper with a max. width of 118mm.
- ****With the cutter installed, set the stop position in Qlabel to 30, and the E value to 30.

5 Accessories

2. Place the cutter to align both holes of screw and then tighten the screws.

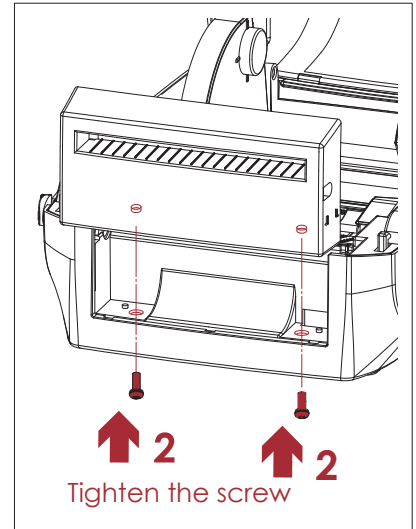
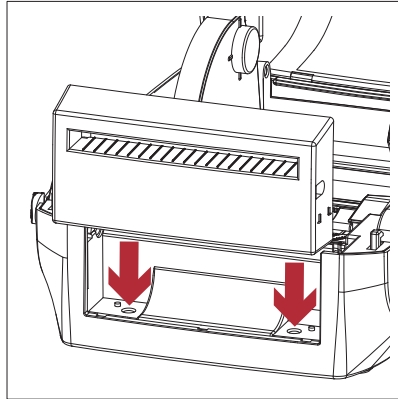
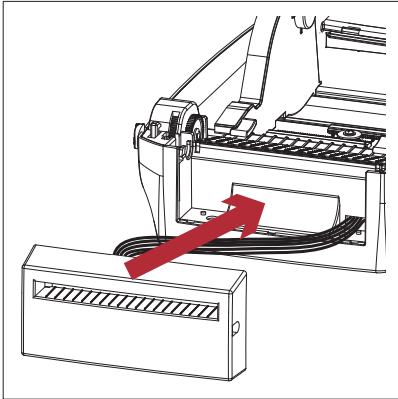

3. Place the platen back to the printer and lock the clips.

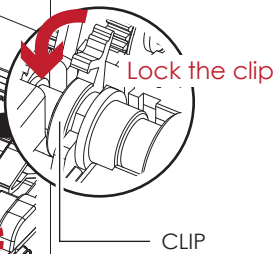
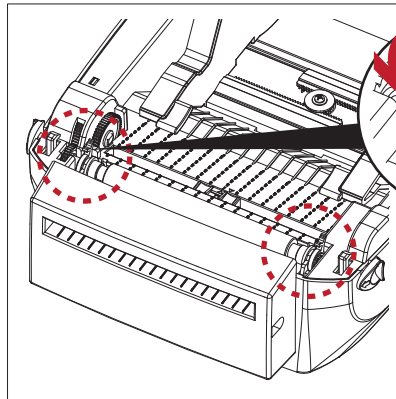
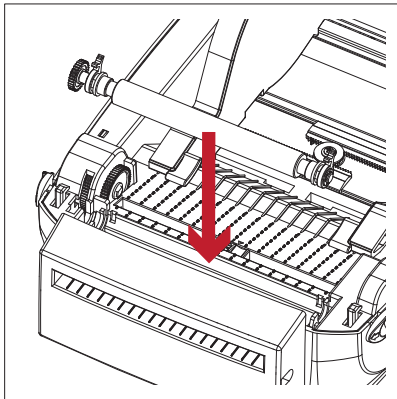

4. Close the printer cover and printing mechanism. Then to turn the printer upside down.

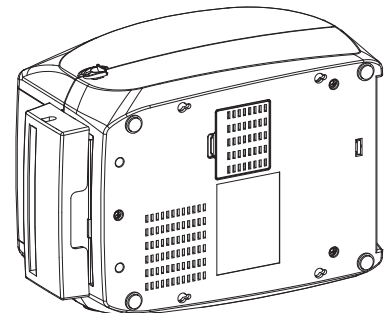
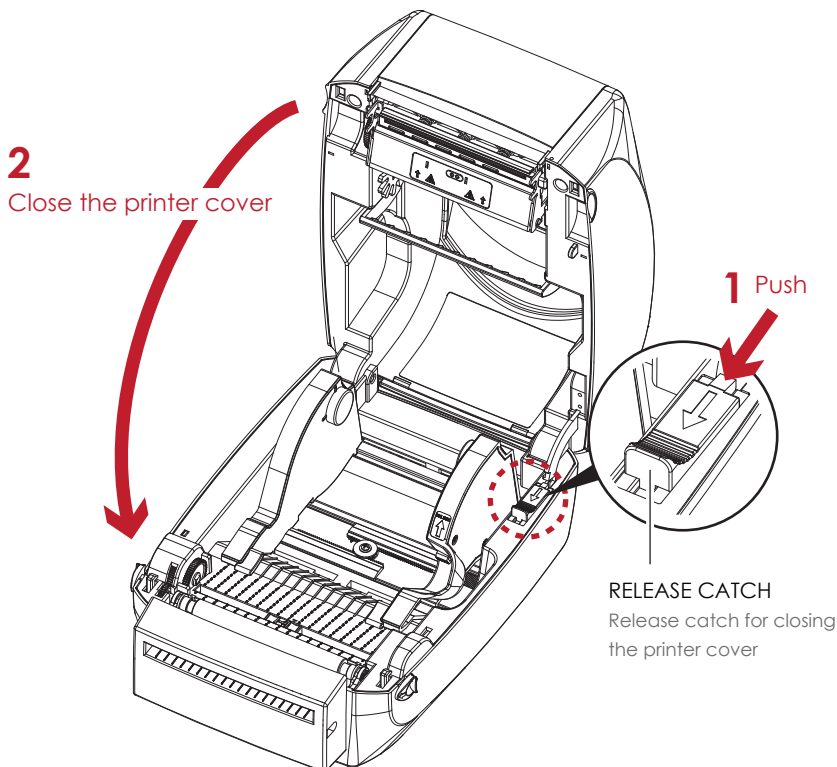

5 Accessories

5. Open the cover on the bottom of printer.

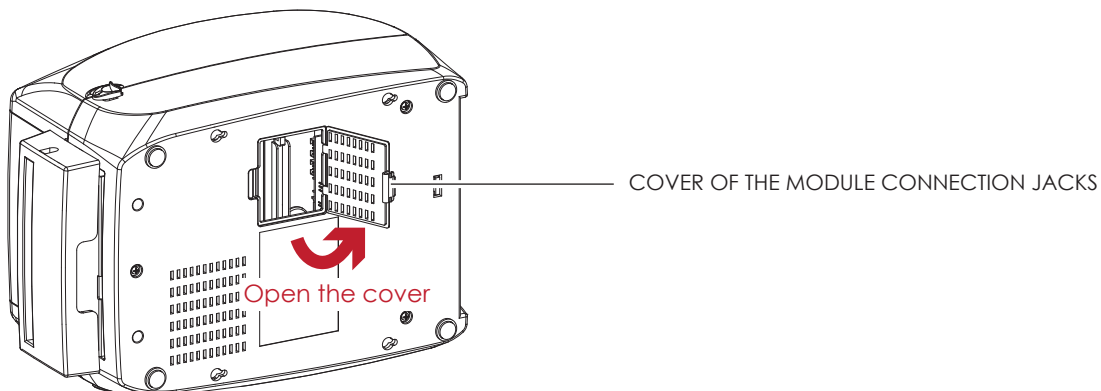

6. Plug the connector for the cutter to the jack.

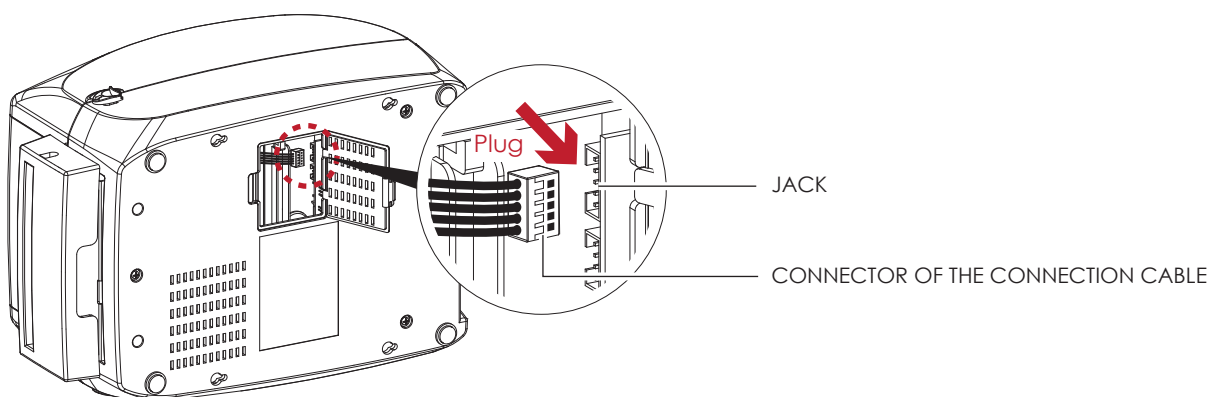

7. Close the cover of the module connection jacks.

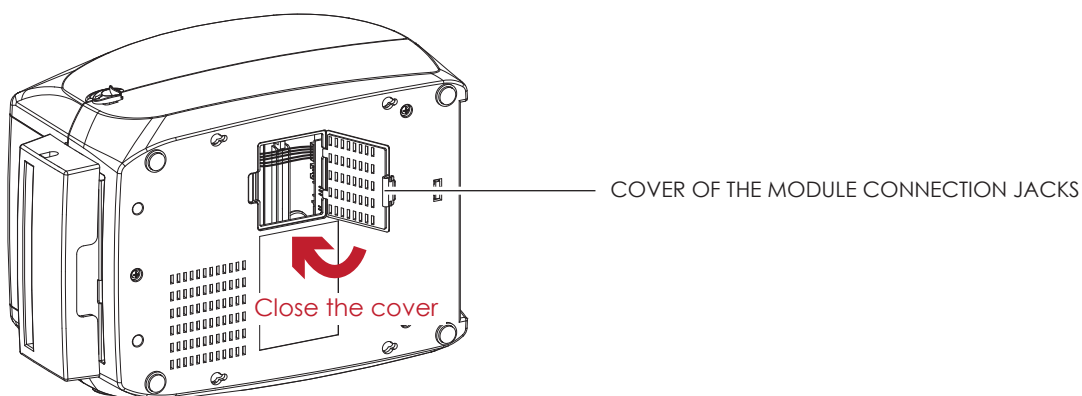

Notice

- * The printer must be switched off, or the motherboard may be destroyed!
- ** There are 2 jacks : the lower jack for the label dispenser, the upper jack for the cutter.

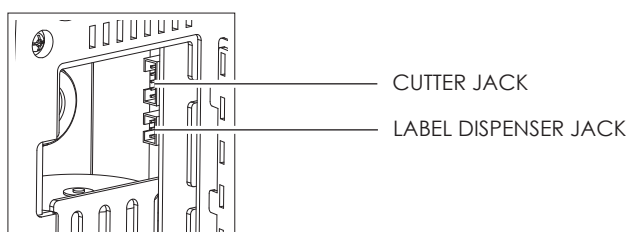

5 Accessories

Installing the Label Roll Module on the Printer

1. Pass the labels through the guides and the cutter.

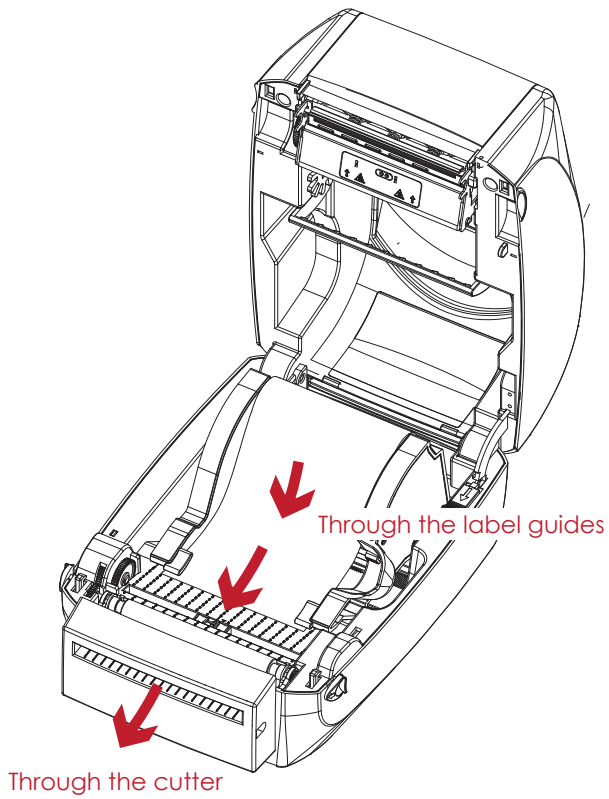

2. Close the top cover and printing mechanism. To finish, press the FEED button to set the label position.

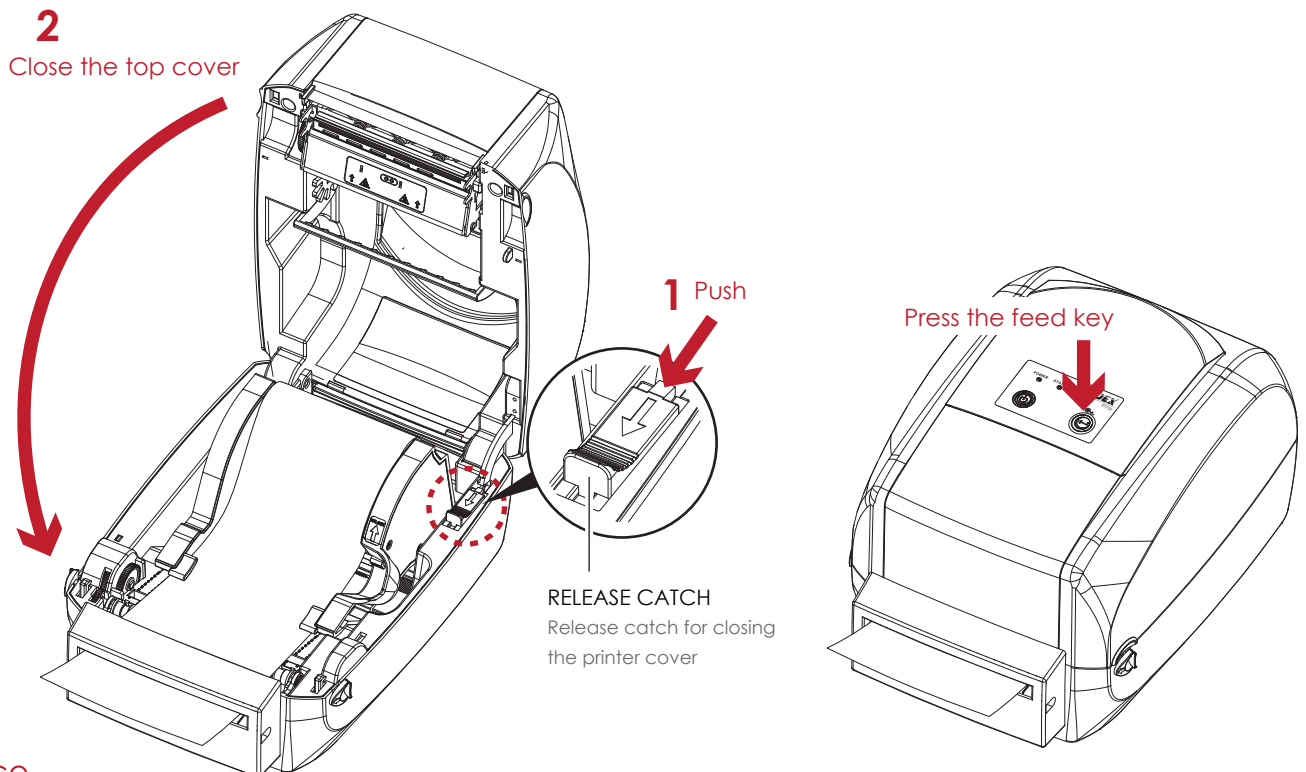

Notice

- * We advise against using inside wound label stock.
- ** Labels should be at least 30 mm high. When using the printer with the cutter, you should set the stop position (^E) to 30.

6 Maintenance and Adjustment

6.1 Cleaning the Print Head

Dirt on the print head or ribbon, or glue residue from the label stock may result in inadequate print quality. The printer cover must therefore always be closed during printing. Keeping dirt and dust away from the paper or labels ensures a good print quality and a longer lifespan of the print head.

Cleaning Steps

Here is how you clean the print head.

1. Turn off the printer.
2. Open the printer cover.
3. Remove the ribbon.
4. To remove any label residue or other dirt from the print head (see red arrow), please use a soft lint-free cloth dipped in alcohol.

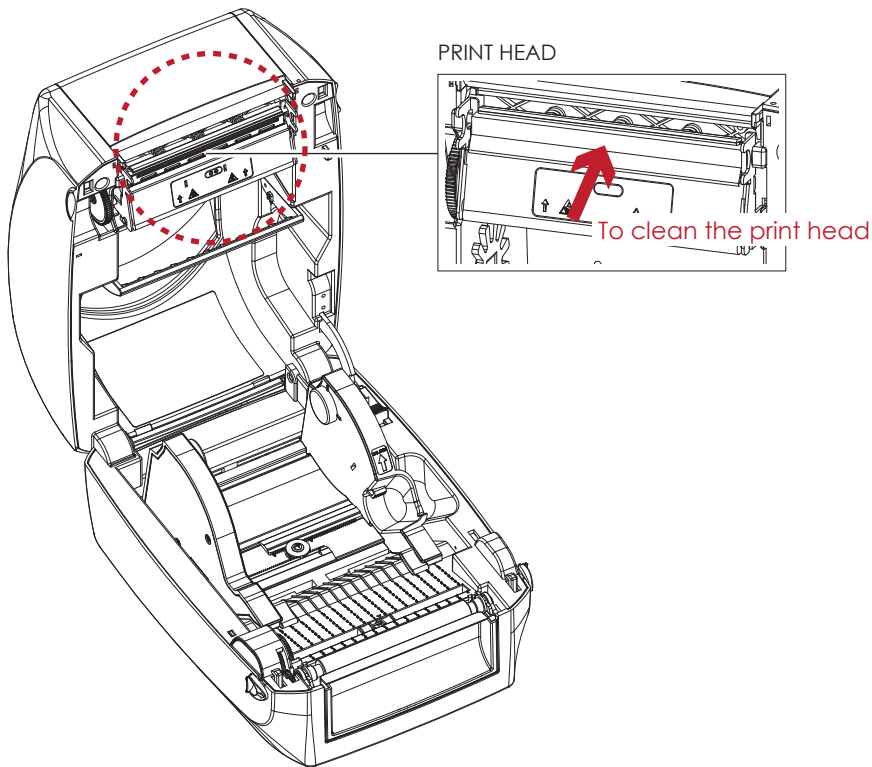

Notice

-
- * The print head should be cleaned once a week.
 - ** Please make sure that there are no metal fragments or other hard particles on the soft cloth used to clean the print head.

6 Maintenance and Adjustment

6.2 Troubleshooting

Problem	Solution
The printer is switched on but the LED does not light up.	<ul style="list-style-type: none"> ◆ Check the power supply. <p>Please see the Section 2.4</p>
The LED lights up red and printing is interrupted.	<ul style="list-style-type: none"> ◆ Check the software settings (driver settings) or command codes. ◆ Look for the error alert in the table in Section 3.5. Error Alerts. ◆ Check whether the print mechanism is closed correctly. <p>Please see the Section 3.5</p>
The label stock passes through the printer but no image is printed.	<ul style="list-style-type: none"> ◆ Please make sure that the label stock is loaded the right way up and that it is suitable material. ◆ Choose the correct printer driver. ◆ Choose the correct label stock and a suitable printing mode.
The label stock jams during printing.	<ul style="list-style-type: none"> ◆ Clear the paper jam. Remove any label material left on the thermal print head and clean the print head using a soft lint-free cloth dipped in alcohol. <p>Please see the Section 6.1</p>
There is no printed image on some parts of the label.	<ul style="list-style-type: none"> ◆ Check whether any label material or ribbon is stuck to the thermal print head. ◆ Check for errors in the application software. ◆ Check whether the starting position has been set incorrectly. ◆ Check the ribbon for wrinkles.
There is no printed image on part of the label or the image is blurred.	<ul style="list-style-type: none"> ◆ Check the thermal print head for dust or other dirt. ◆ Use the internal "~T" command to check whether the thermal print head will carry out a complete print job. ◆ Check the quality of the print medium.
The printed image is positioned incorrectly.	<ul style="list-style-type: none"> ◆ Check whether there is paper or dust covering the sensor. ◆ Check whether the label stock is suitable. Contact your supplier. ◆ Check the paper guide settings.
A label is missed out during printing.	<ul style="list-style-type: none"> ◆ Check the label height setting. ◆ Check whether there is dust covering the sensor. ◆ Run the auto-detection function. <p>Please see the Section 3.4</p>
The printed image is blurred.	<ul style="list-style-type: none"> ◆ Check the darkness setting. ◆ Check the thermal print head for dust or dirt. <p>Please see the Section 6.1</p>
The cutter does not cut off the labels in a straight line.	<ul style="list-style-type: none"> ◆ Check whether the label stock is positioned straight.
The cutter does not cut off the labels completely.	<ul style="list-style-type: none"> ◆ Check whether the label is more than 0.2 mm thick.
When using the cutter, the labels are not fed through or cut off incorrectly.	<ul style="list-style-type: none"> ◆ Check whether the cutter has been correctly installed. ◆ Check whether the paper guides are functioning correctly.
The label dispenser is not functioning normally.	<ul style="list-style-type: none"> ◆ Check whether there is dust on the label dispenser. ◆ Check whether the label stock is positioned correctly.

Notice

* If any problems occur that are not described here, please contact your dealer.

APPENDIX

PRODUCT SPECIFICATIONS

Model	RT700	RT730	
Print Method	Thermal Transfer / Direct Thermal		
Resolution	203 dpi (8 dots/mm)	300 dpi (12 dots/mm)	
Print Speed	5 IPS (127 mm/s)	4 IPS (102 mm/s)	
Print Width	4.25" (108 mm)	4.16" (105.7 mm)	
Print Length	Min. 0.16" (4 mm)**; Max. 68" (1727 mm)	Min. 0.16" (4 mm)**; Max. 30" (762 mm)	
Processor	32 bit RISC CPU		
Memory	Flash	8 MB Flash (4 MB for user storage)	
	SDRAM	16 MB SDRAM	
Sensor Type	Adjustable reflective sensor (full range) Fixed transmissive sensor, central aligned		
Media	Types	Continuous form, gap labels, black mark sensing and punched hole; label length set by auto sensing or programming	
	Width	Min. 1" (25.4 mm) – Max. 4.64" (118 mm)	
	Thickness	Min. 0.003" (0.06 mm) – Max. 0.01" (0.2 mm)	
	Label Roll Diameter	Max. 5" (127 mm)	
Ribbon	Core Diameter	1" (25.4 mm), 1.5" (38.1 mm)	
	Types	Wax, wax / resin, resin	
	Length	981' (300 m)	
	Width	Min. 1.18" (20 mm) – Max. 4.33" (118 mm)	
Printer Language	Ribbon Roll Diameter	Max. 2.67" (68 mm)	
	Core Diameter	1" (25.4 mm)	
	Printer Language	EZPL, GEPL, GZPL auto switch	
Software	Label Design Software	GoLabel (for EZPL only)	
	Driver	Windows 2000, XP, Vista, 7, Windows Server 2003 & 2008	
	DLL	Windows 2000, XP and Vista	
Resident Fonts	Bitmap Fonts	6, 8, 10, 12, 14, 18, 24, 30, 16X26 and OCR A&B Bitmap fonts 90°, 180°, 270° rotatable, single characters 90°, 180°, 270° rotatable Bitmap fonts 8 times expandable in horizontal and vertical directions	
	Scalable Fonts	90°, 180°, 270° rotatable	
Download Fonts	Bitmap Fonts	Bitmap fonts 90°, 180°, 270° rotatable, single characters 90°, 180°, 270° rotatable	
	Asian Fonts	Asian fonts 90°, 180°, 270° rotatable and 8 times expandable in horizontal and vertical directions	
Barcodes	Scalable Fonts	Scalable fonts 90°, 180°, 270° rotatable	
	1-D Bar codes	Code 39, Code 93, EAN 8 / 13 (add on 2 & 5), UPC A / E (add on 2 & 5), I 2 of 5 & I 2 of 5 with Shipping Bearer Bars, Codabar, Code 128 (subset A, B, C), EAN 128, RPS 128, UCC 128, UCC / EAN-128 K-Mart, Random Weight, Post NET, IIF 14, China Postal Code, HIBC, MSI, Plessey, Telepen, FIM and GS1 DataBar	
	2-D Bar codes	PDF417, Datamatrix code, MaxiCode, QR code, Micro PDF417, Micro QR code and Aztec code	
Code Pages	CODEPAGE 437, 850, 851, 852, 855, 857, 860, 861, 862, 863, 865, 866, 869 and 737 WINDOWS 1250, 1251, 1252, 1253, 1254, 1255 and 1257 Unicode (UTF8, UTF16)		
Graphics	Resident graphic file types are BMP and PCX, other graphic formats are downloadable from the software		
Interfaces	USB 2.0	USB 2.0	USB 2.0
	Serial port: RS-232 (DB-9)	Serial port: RS-232(DB-9)	Serial port: RS-232 (DB-9)
Control Panel	Ethernet 10/100 Mbps	Parallel port	Ethernet 10/100 Mbps
	Parallel port		Parallel port
Real Time Clock	Two dual color LEDs (Ready & Status) Calibration button Control key: FEED Power on / off button		
Environment	Power	Standard	
	Operation Temperature	Auto Switching 100-240V AC, 50-60Hz	
	Storage Temperature	41°F to 104°F (5°C to 40°C)	
Humidity	Operation	-4°F to 122°F (-20°C to 50°C)	
	Storage	30-85%, non-condensing	
Agency Approvals	10-90%, non-condensing		
Dimension	Length	CE(EMC), FCC Class A, CB, CCC, cUL	
	Height	11.0" (280 mm)	
	Width	7.3" (186 mm)	
Weight	8.3" (210 mm)		
Options	Weight	6 lbs (2.72 Kg), excluding consumables	
	Guillotine Cutter		
	Label Dispenser		
External label roll holder for 10" (250 mm) O.D. label rolls			
External label rewinder			

* Specifications are subject to change without notice. All company and/or product names are trademarks and/or registered trademarks of their respective owners.

** Minimum print height and maximum print speed specification compliance can be dependent on non-standard material variables such as label type, thickness, spacing, liner construction, etc. Godex is pleased to test non-standard materials for minimum print height and maximum print speed capability.

APPENDIX

INTERFACE

Pinout Description

- USB

Connector Type : Type B

Pin NO.	1	2	3	4
Function	VBUS	D-	D+	GND

- Serial Port

Default settings : Baud rate 9600, no parity, 8 data bits, 1 stop bit, XON/XOFF protocol and RTS/CTS

RS232 Housing(9-pin to 9-pin)			
DB9 Socket		DB9 Plug	
-	1	1	+5V, max 500mA
RXD	2	2	TXD
TXD	3	3	RXD
DTR	4	4	N/C
GND	5	5	GND
DSR	6	6	RTS
RTS	7	7	CTS
CTS	8	8	RTS
RI	9	9	N/C
Computer			Printer

Notice

- * The total current to the serial port may not exceed 500mA.