

INSTRUCTIONS

ULTIMATE GARAGE™

INCLUDES 5 VEHICLES. ADDITIONAL VEHICLES SOLD SEPARATELY. 1100453471-00M

ADULT ASSEMBLY REQUIRED

REQUIRES 3 AA SIZE (LR6) ALKALINE BATTERIES (NOT INCLUDED). DISPOSE OF BATTERIES SAFELY.

PLEASE KEEP THESE INSTRUCTIONS FOR FUTURE REFERENCE AS THEY CONTAIN IMPORTANT INFORMATION.

5+ www.hotwheels.com

FCC Rpt. 00007-189071 is required to be placed inside the packaging.

INDEX

BATTERY INSTALLATION	2
CONTENTS	3
ASSEMBLE ZONE 1	4
ASSEMBLE ZONE 2	8
ASSEMBLE ZONE 3	11
COMPLETED ASSEMBLY	13
TO PLAY	14
MORE WAYS TO PLAY	19
PERFORMANCE TIPS	20
BATTERY SAFETY INFORMATION	20

BATTERY INSTALLATION

- Unscrew the battery cover with a Phillips head screwdriver (not included).
- Install 3 new AA (LR6) alkaline batteries (not included) in the orientation (+/-) shown.
- Replace battery cover and tighten screw.
- For longer life use alkaline batteries.
- Replace batteries when lights dim or sounds become distorted.
- When exposed to an electrostatic source, the product may malfunction. To resume normal operation, remove and re-install the batteries.

CONTENTS

ZONE 1

ZONE 2

ZONE 3

LABEL SHEET

ASSEMBLE ZONE 1 Install batteries as described on page 2 before beginning assembly.

1.

2.

3.

4.

5.

6.

7.

8.

9.

9.

INDEX

BATTERY INSTALLATION 2

CONTENTS 3

ASSEMBLE ZONE 1 4

ASSEMBLE ZONE 2 8

ASSEMBLE ZONE 3 11

COMPLETED ASSEMBLY 13

TO PLAY 14

MORE WAYS TO PLAY 19

PERFORMANCE TIPS 20

BATTERY SAFETY INFORMATION 20

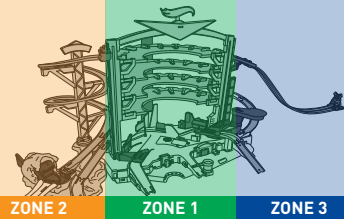

BATTERY INSTALLATION

- Unscrew the battery cover with a Phillips head screwdriver (not included).
- Install 3 new AA (LR6) alkaline batteries (not included) in the orientation (+/-) shown.
- Replace battery cover and tighten screw.
- For longer life use alkaline batteries.
- Replace batteries when lights dim or sounds become distorted.
- When exposed to an electrostatic source, the product may malfunction. To resume normal operation, remove and re-install the batteries.

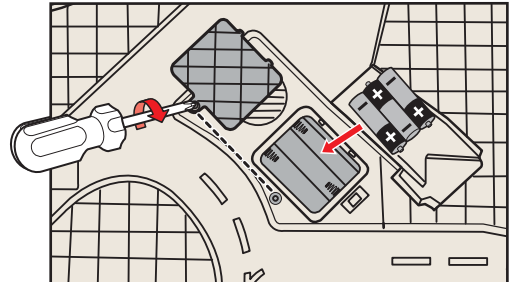

CONTENTS

ZONE 1

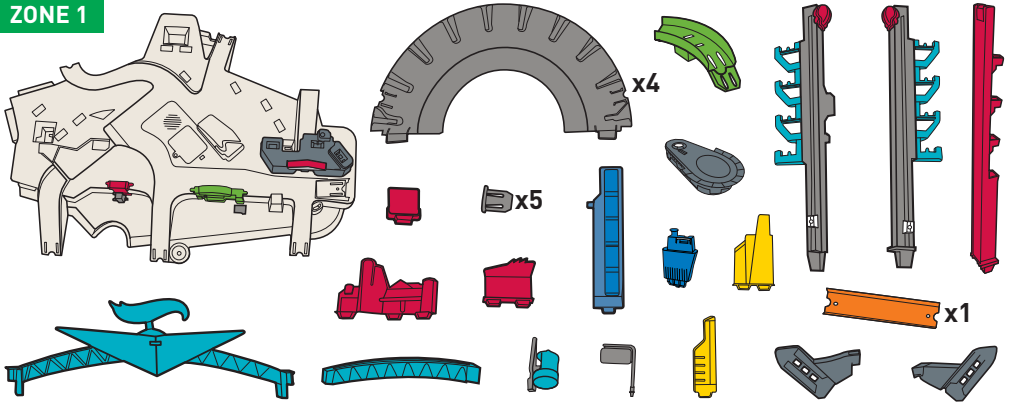

ZONE 2

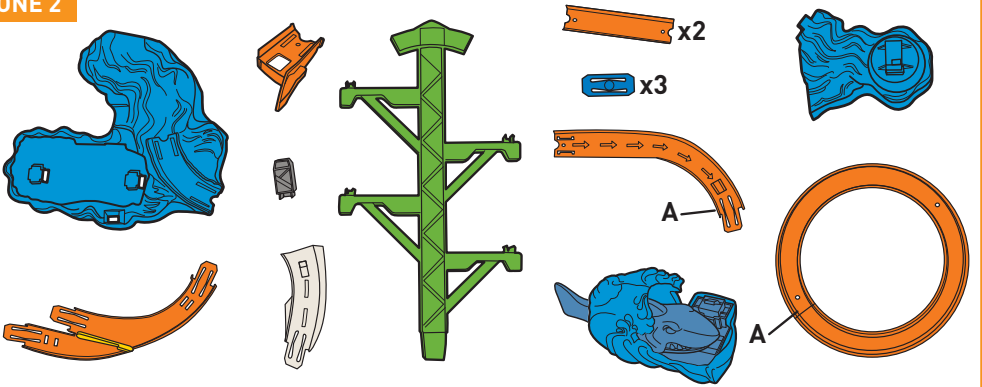

ZONE 3

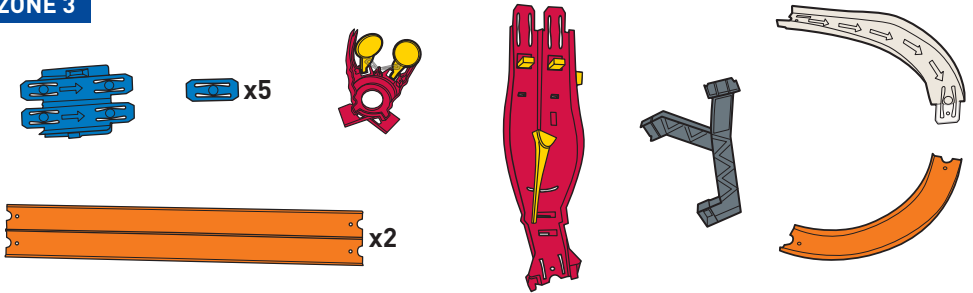

LABEL SHEET

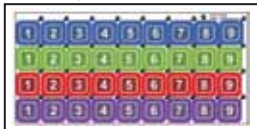

ASSEMBLE ZONE 1

Install batteries as described on page 2 before beginning assembly.

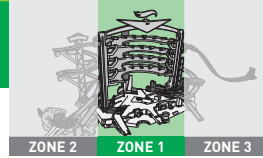

1.

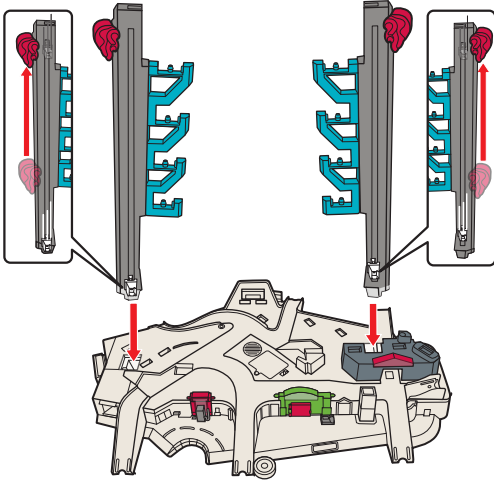

2.

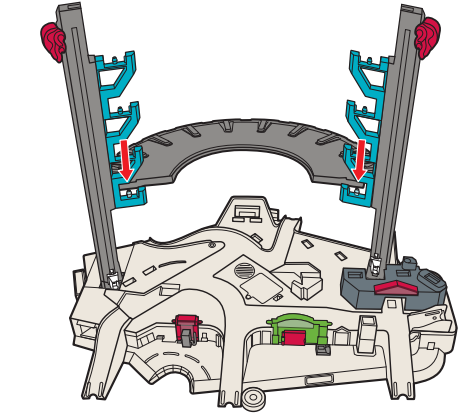
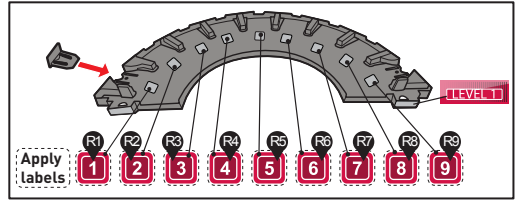

3.

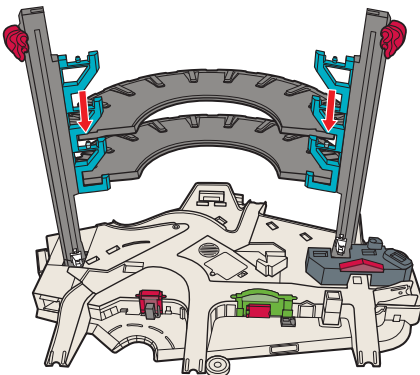
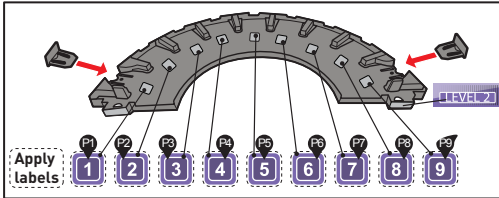

4.

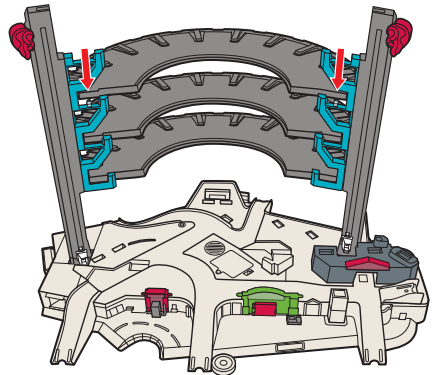
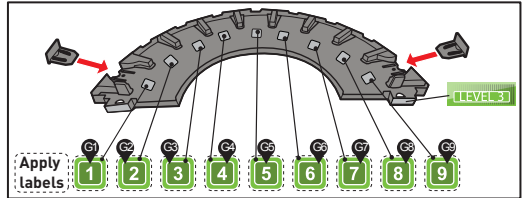

5.

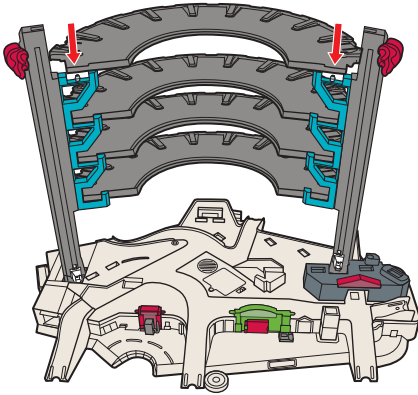
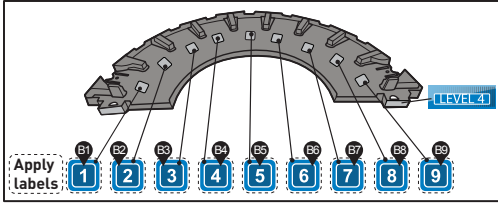

6.

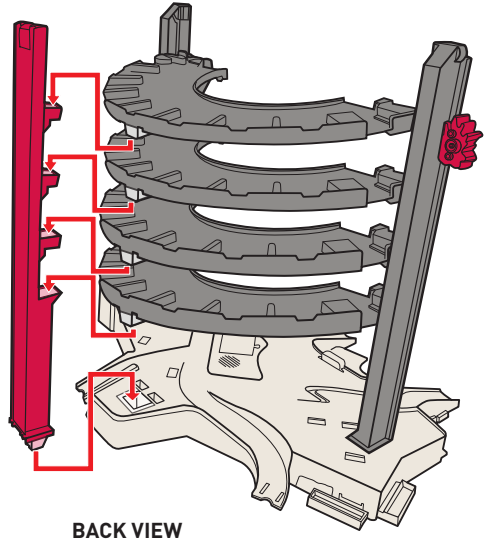

7.

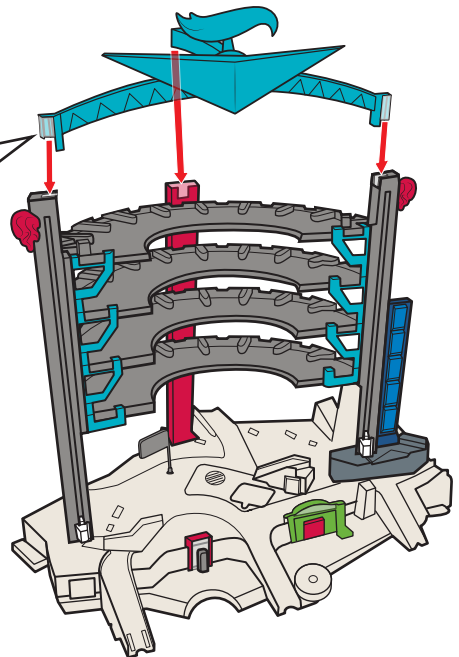
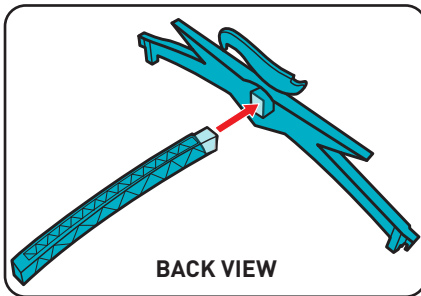

8.

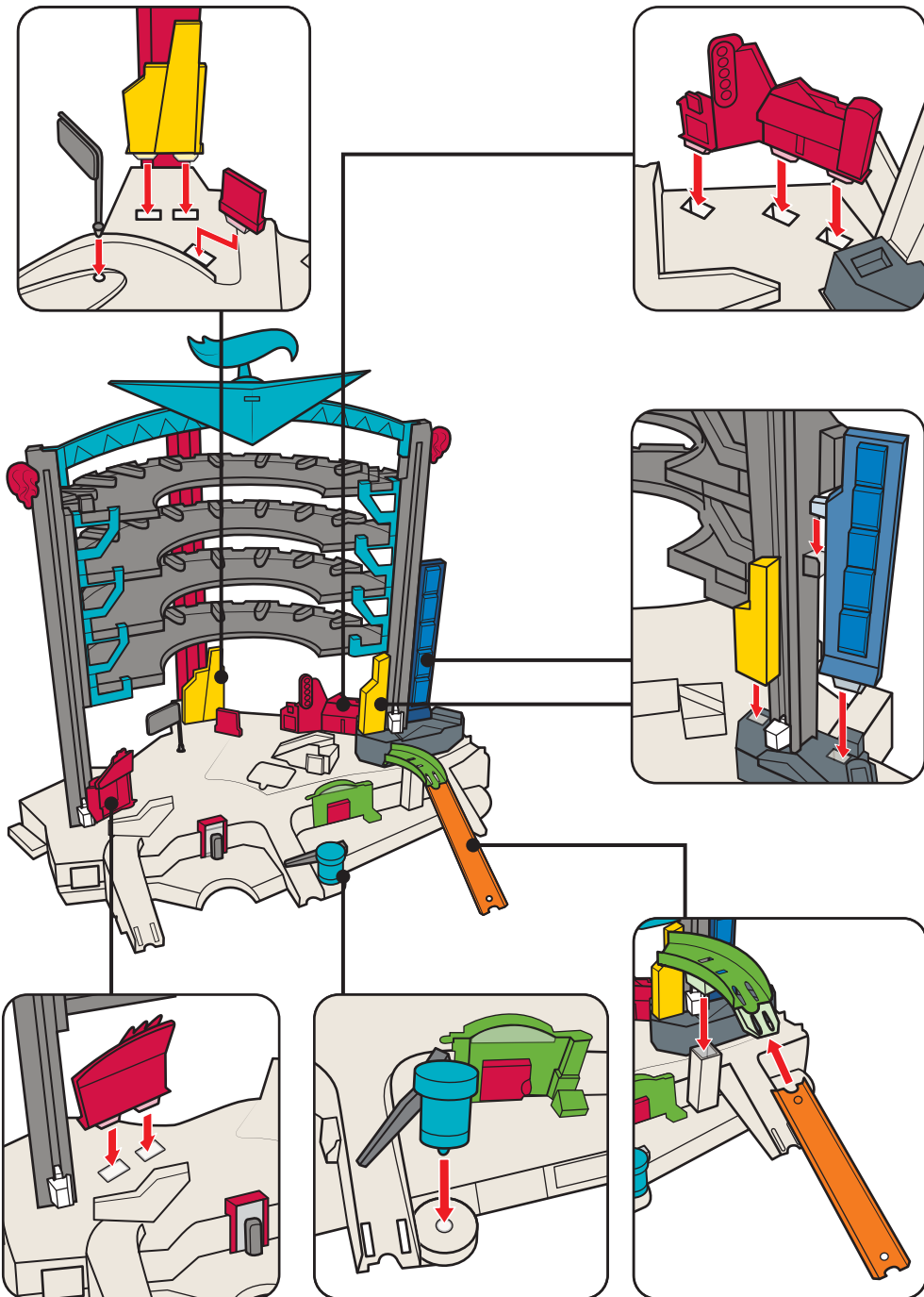

9.

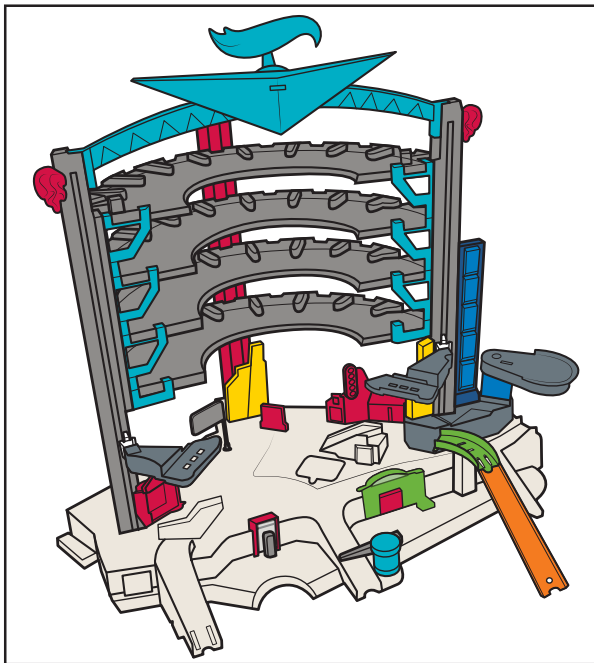
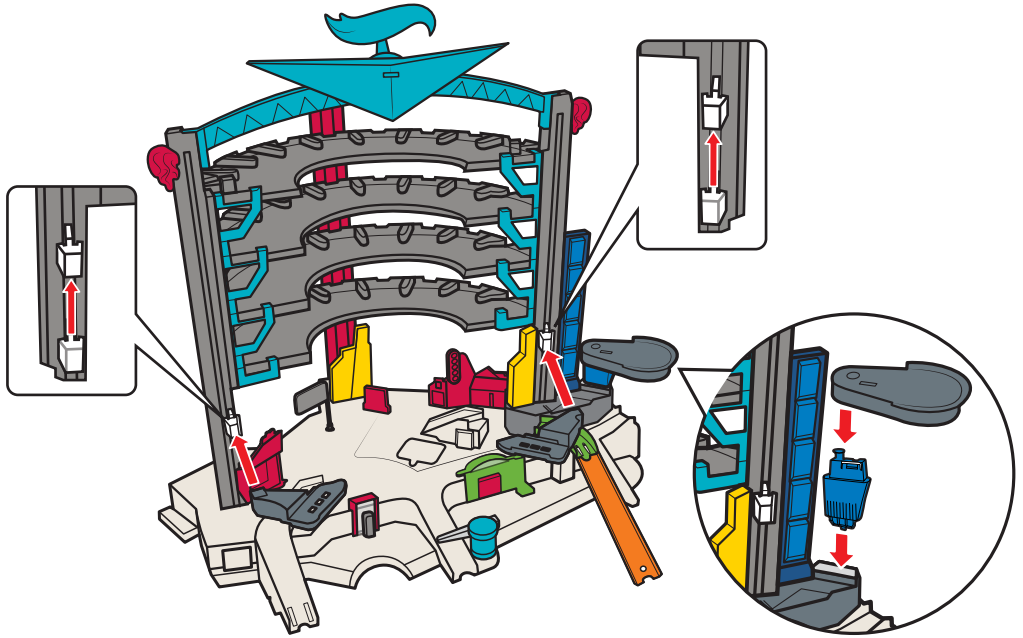

ASSEMBLE ZONE 2

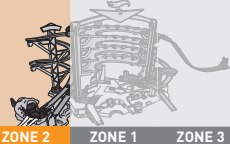

1.

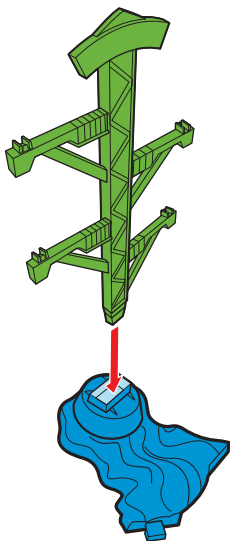

2.

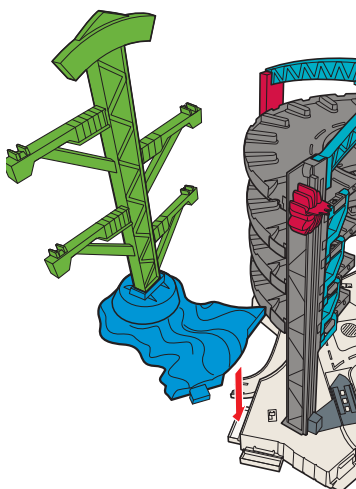

3.

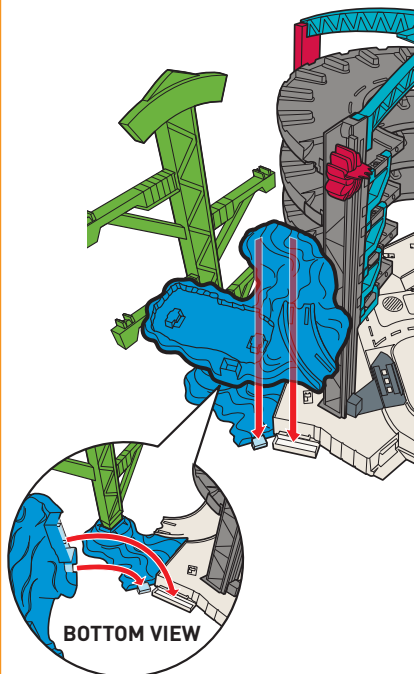

4.

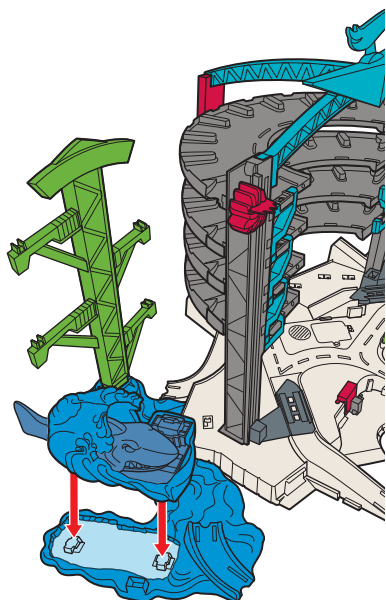

5.

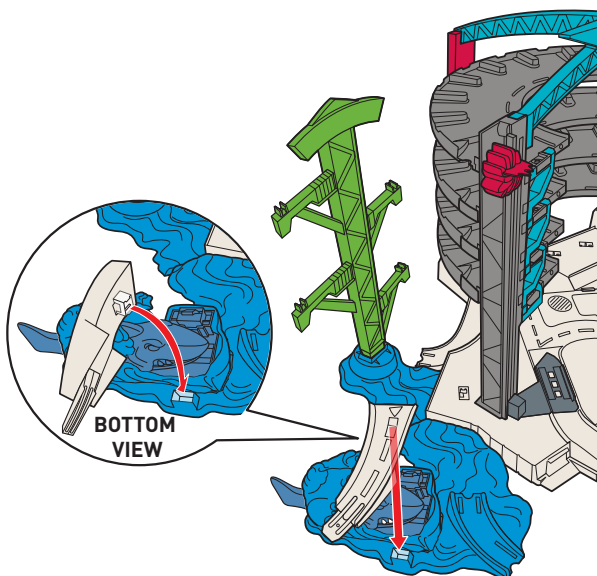

6.

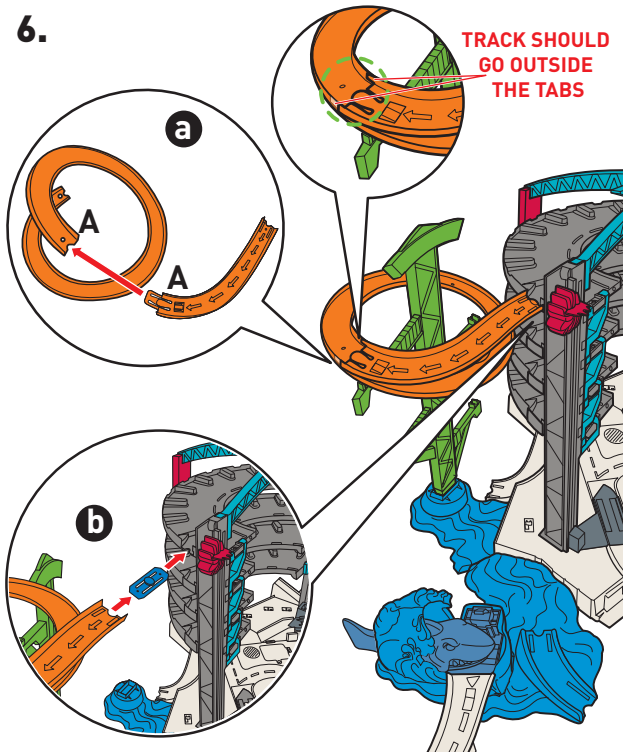

7.

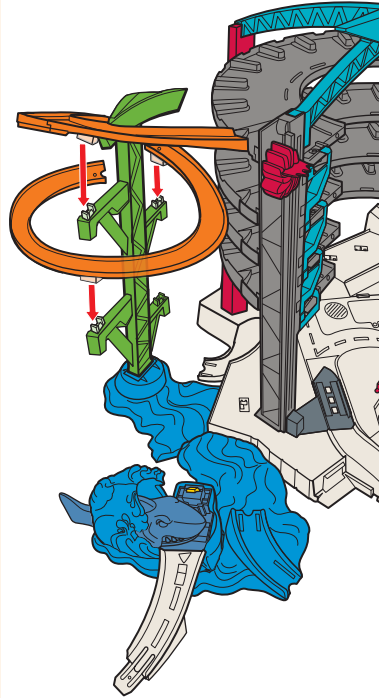

8.

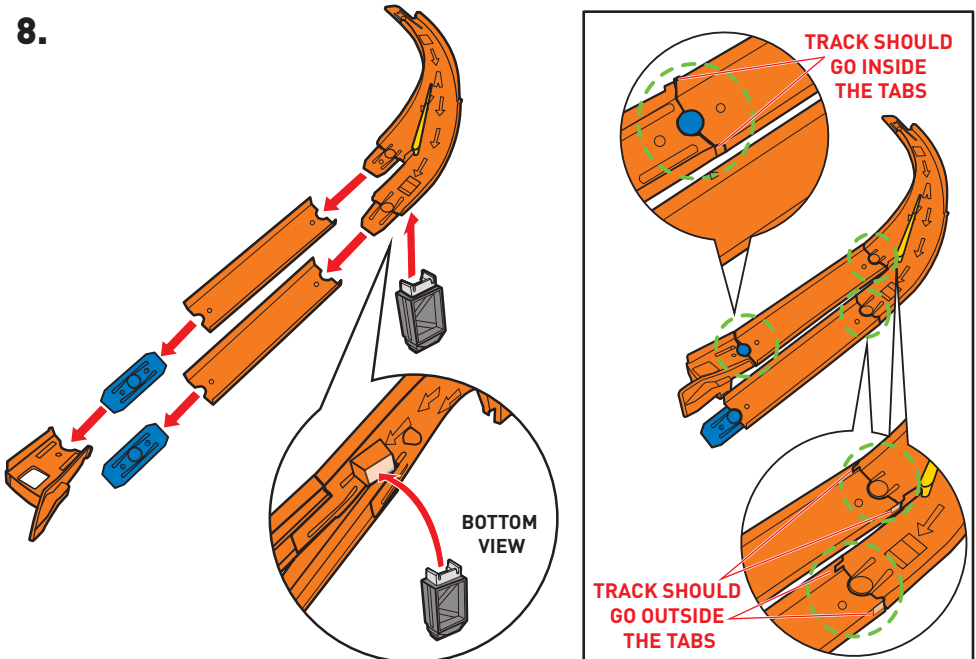

9.

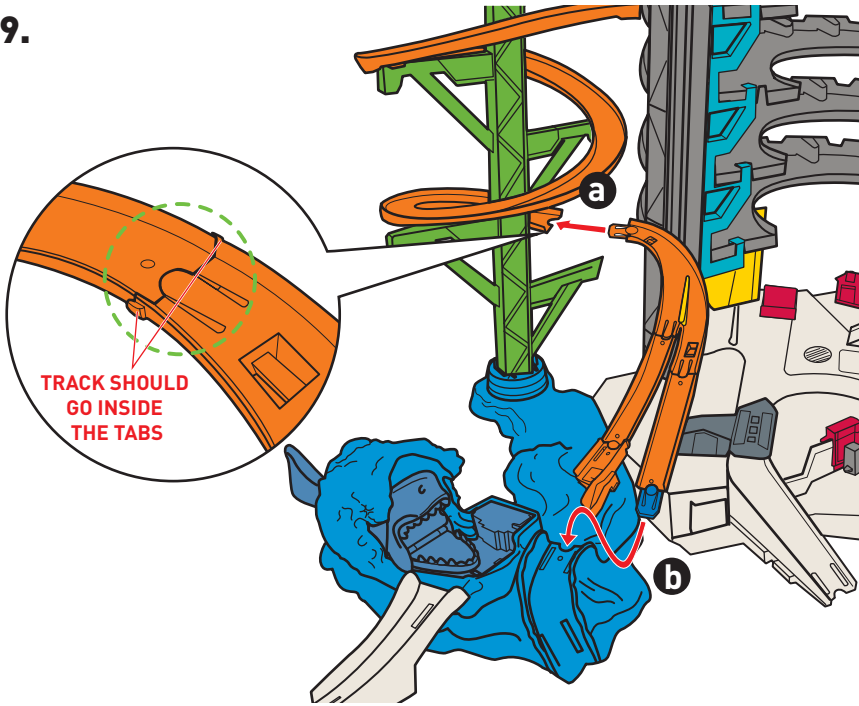

10.

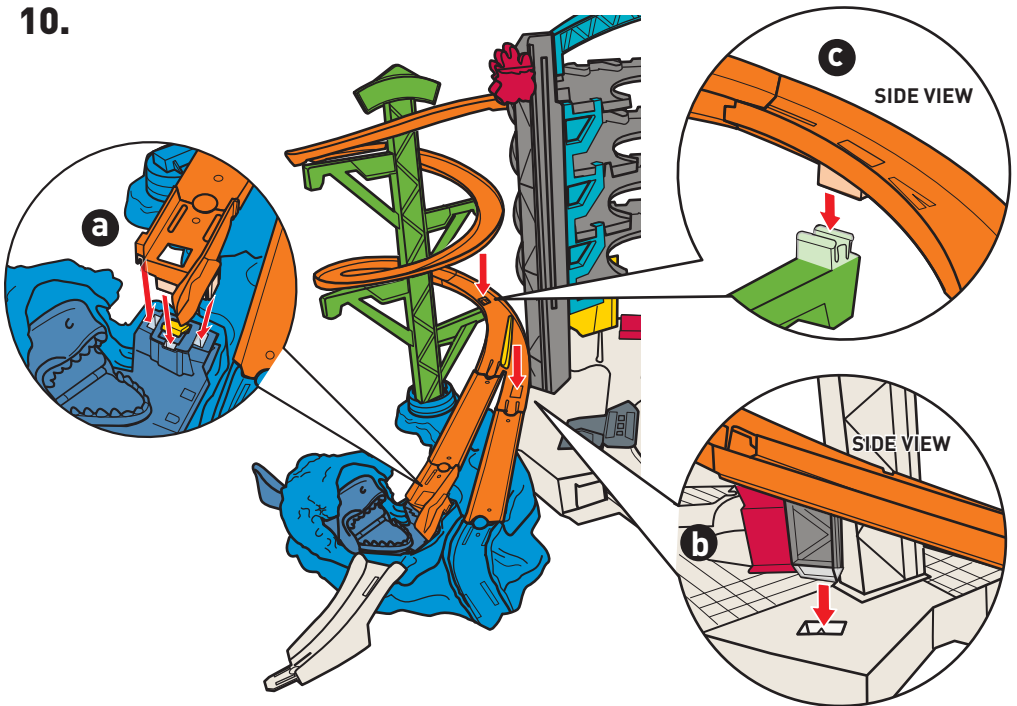

ASSEMBLE ZONE 3

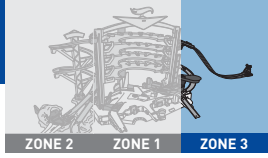

1.

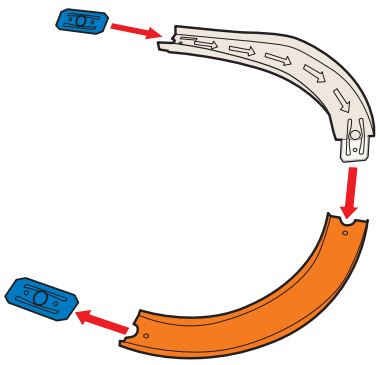

2.

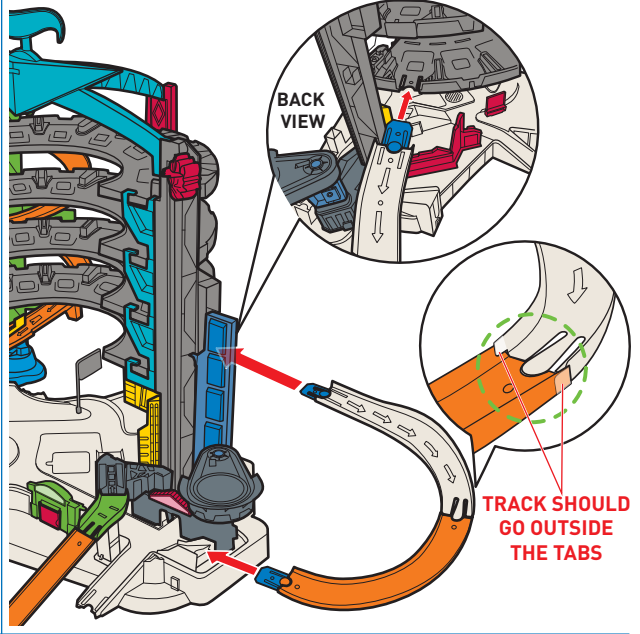

3.

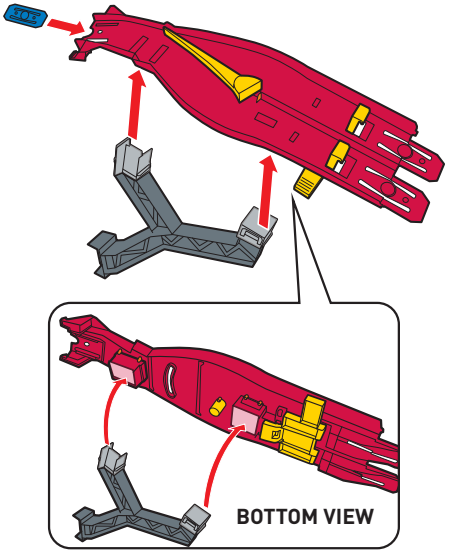

4.

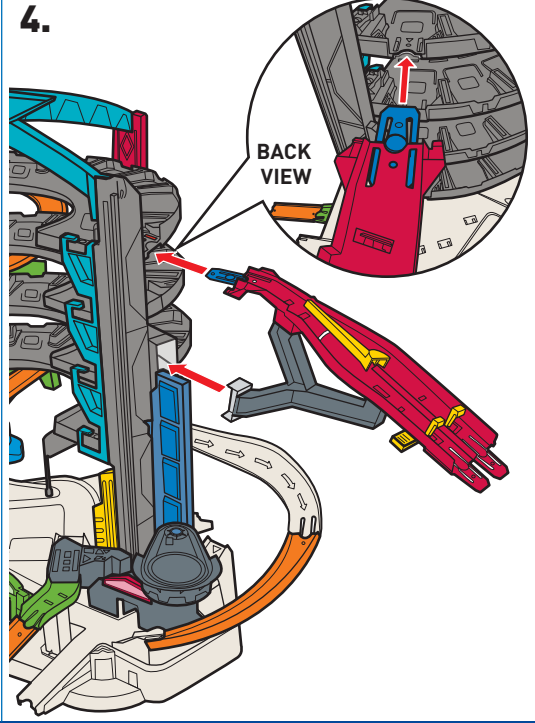

5.

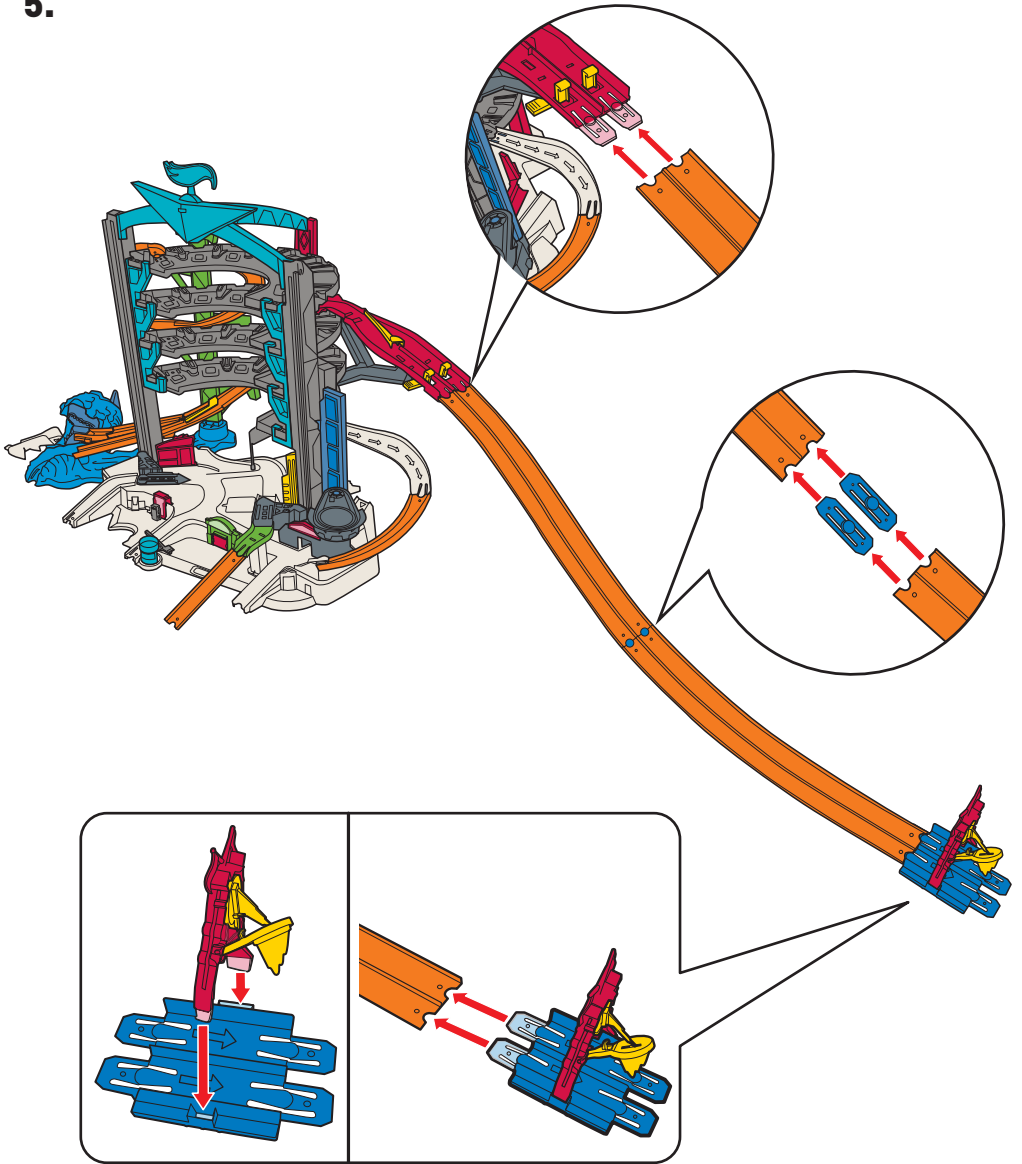

COMPLETED ASSEMBLY

FRONT

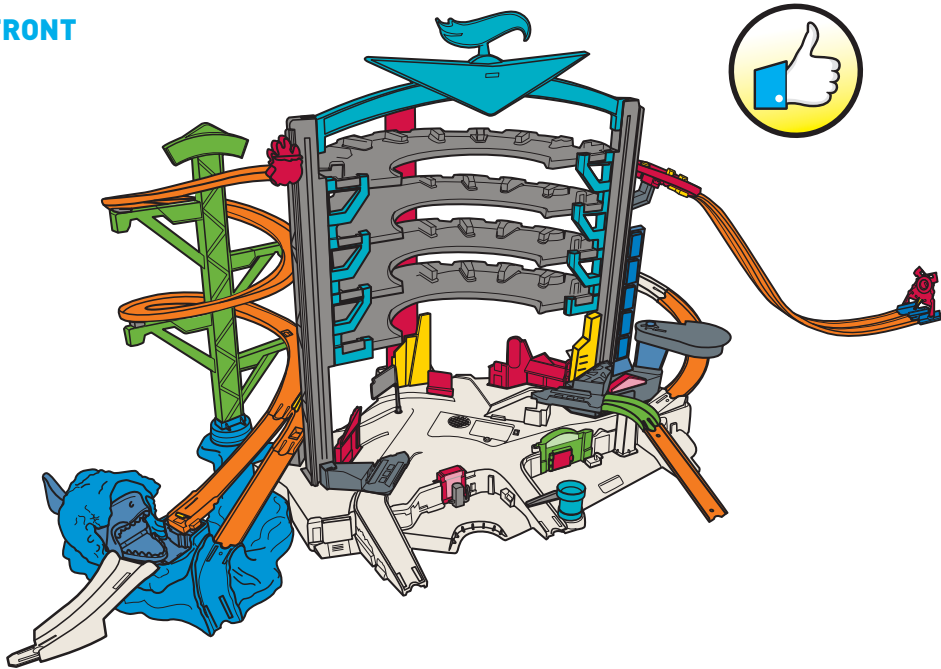

BACK

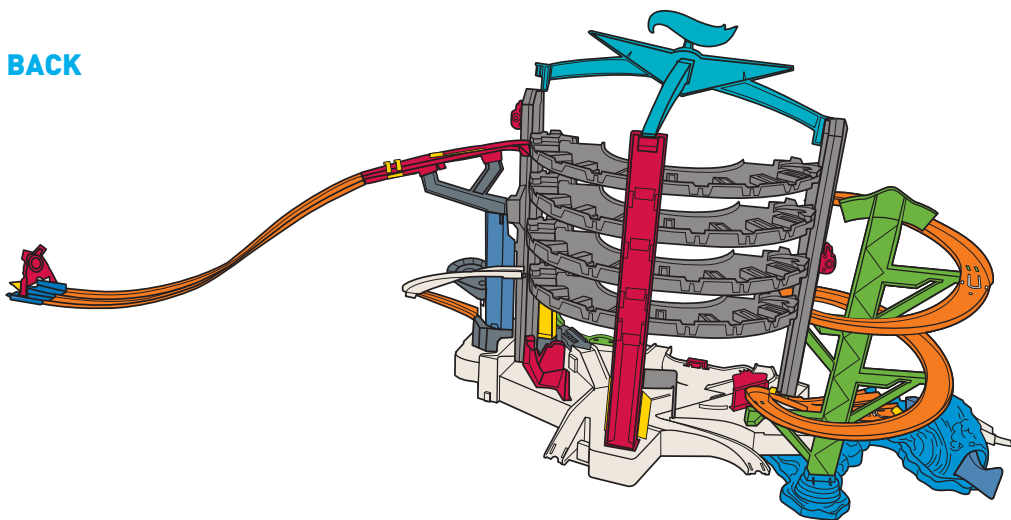

TO PLAY

STORE & DISPLAY
YOUR HOT WHEELS®!

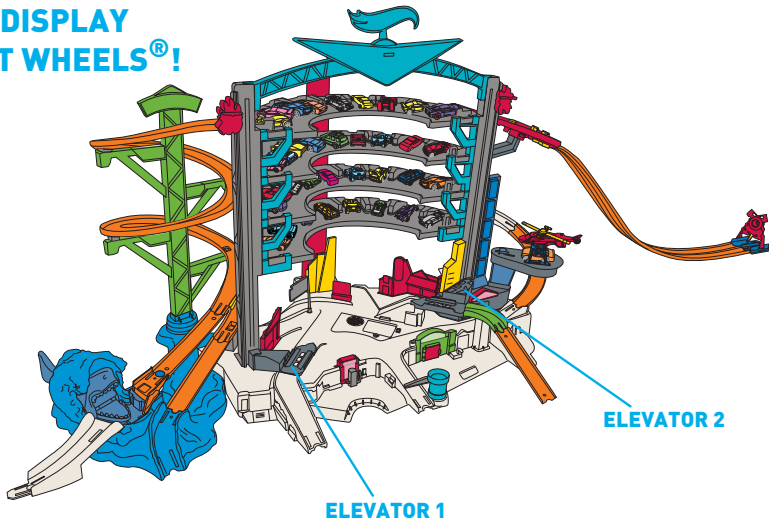

ELEVATOR 1

1. DRIVE CAR ONTO ELEVATOR.

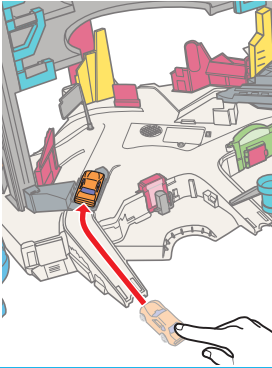

2. PUSH HANDLE DOWN TO RAISE ELEVATOR.

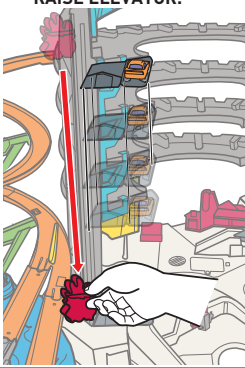

3. DRIVE CAR INTO PARKING BAY.

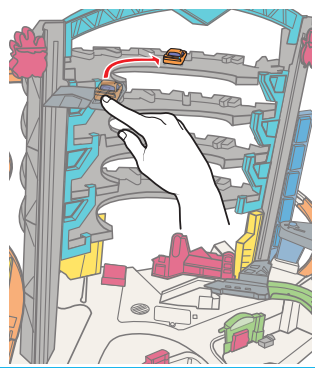

ELEVATOR 2

1. DRIVE CAR ONTO ELEVATOR.

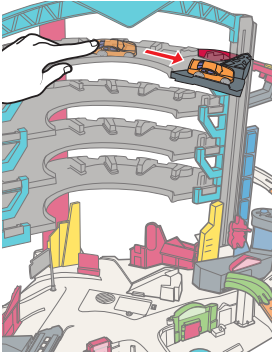

2. LIFT HANDLE UP TO LOWER ELEVATOR.

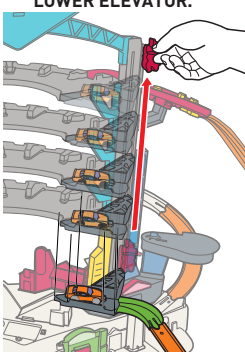

3. RACE DOWN THE RAMP!

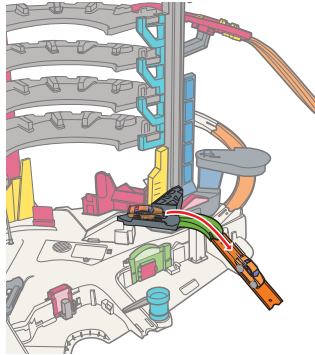

SPIRAL SPEED RAMP

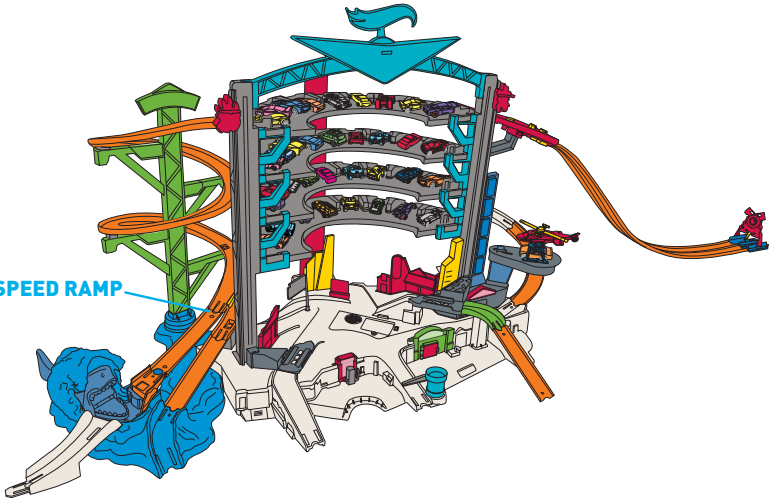

SPIRAL SPEED RAMP

1. SELECT LANE AND PULL TAIL TO RESET SHARK BEFORE PLAY EACH TIME.

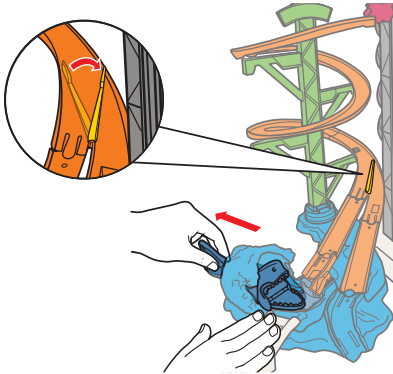

2. WILL YOU GET PAST THE SHARK OR GET CHOMPED?

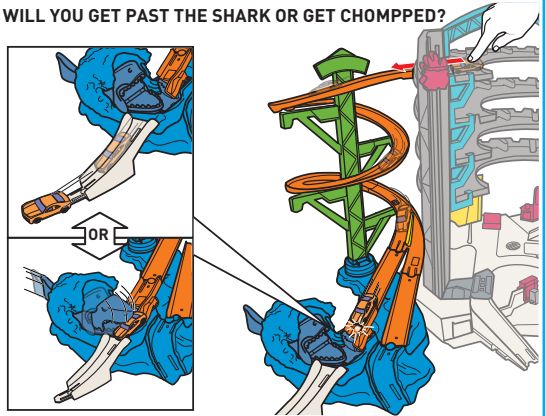

3. USE DIVERTER TO CHANGE LANES.

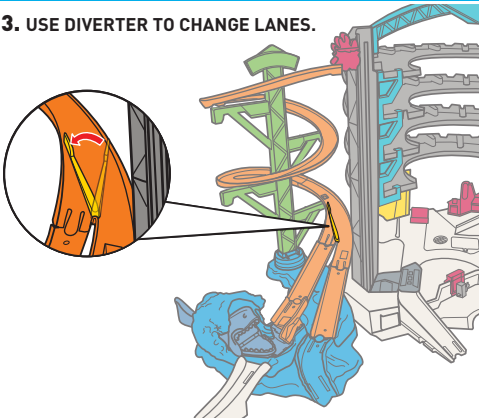

4. RACE DOWN THE SPIRAL RAMP!

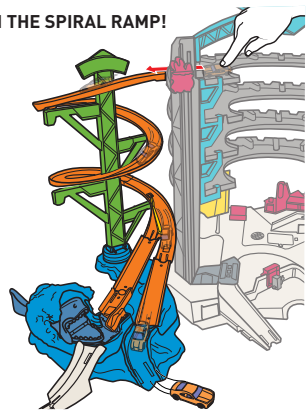

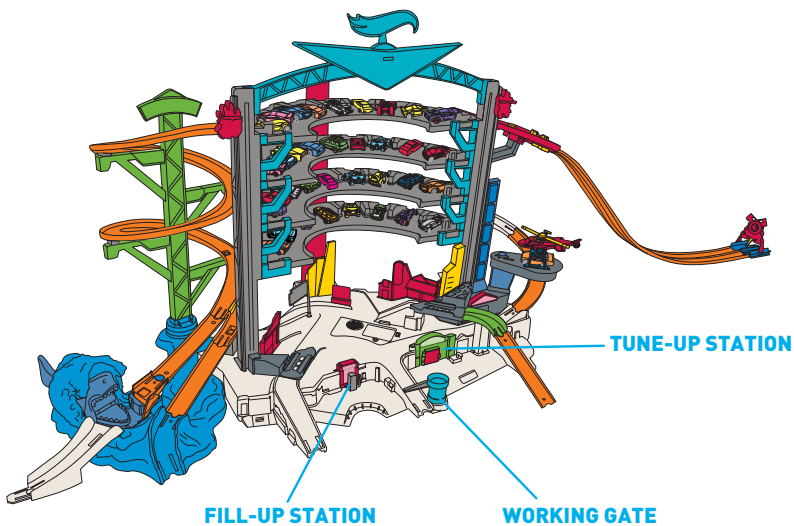

FILL-UP STATION

PRESS FOR LIGHTS AND SOUNDS.

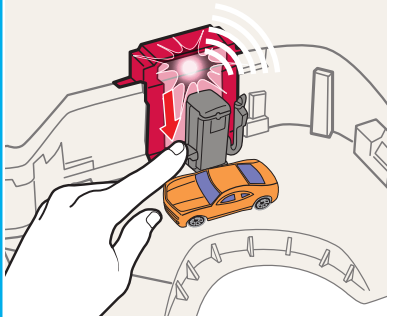

WORKING GATE

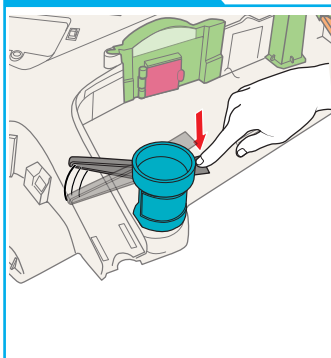

TUNE-UP STATION

1. OPEN DOOR.

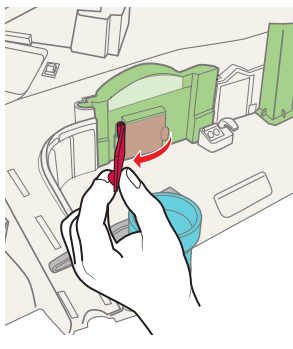

2. PARK CAR INSIDE.

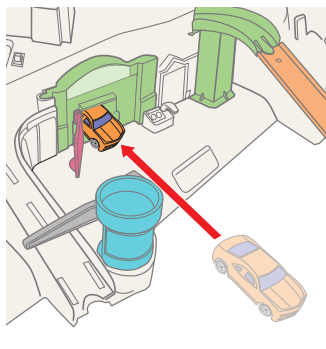

3. PRESS FOR LIGHTS AND SOUNDS.

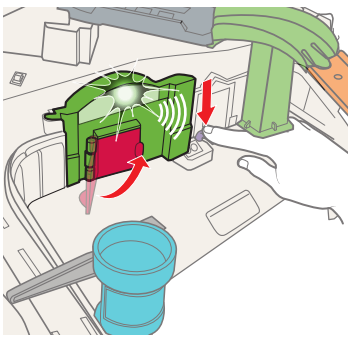

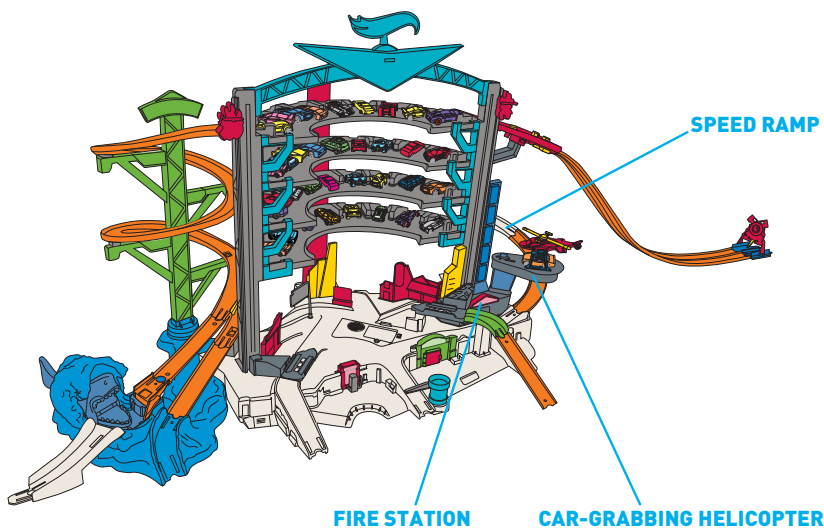

FIRE STATION

1. LOAD CAR ONTO RAMP.

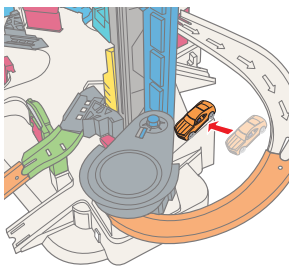

2. RACE THROUGH THE TUNNEL FOR LIGHTS AND SOUNDS.

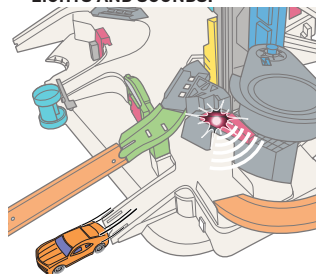

SPEED RAMP

LAUNCH CAR DOWN RAMP.

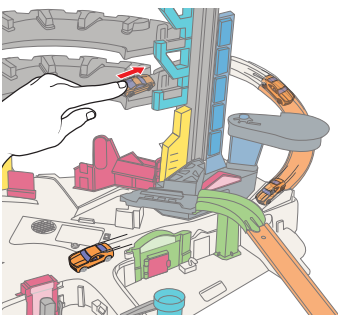

CAR-GRABBING HELICOPTER

1. PINCH SIDES OF HELICOPTER AND GRAB CAR.

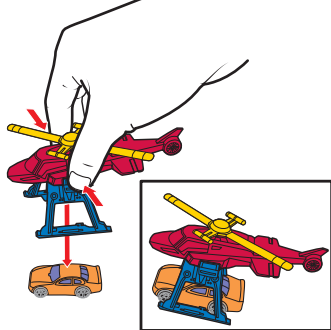

2. LIFT CAR FOR TRANSPORT.

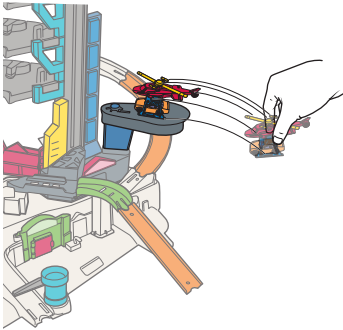

3. PRESS FOR LIGHTS AND SOUNDS.

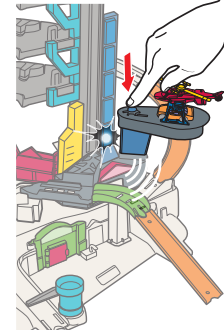

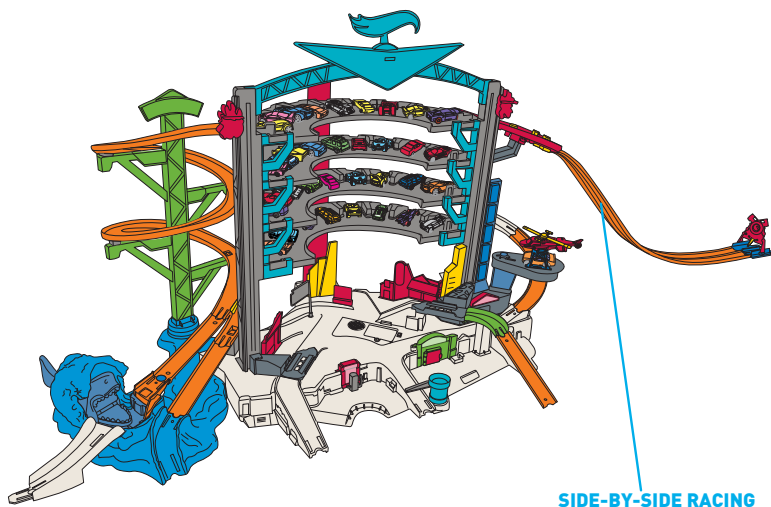

SIDE-BY-SIDE RACING

1. PUSH PANELS DOWN TO RESET BEFORE PLAY.

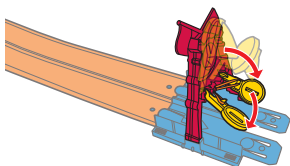

2. LOAD FIRST CAR.

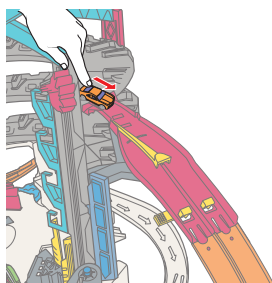

3.

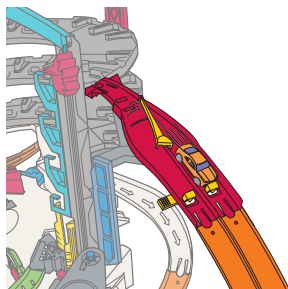

4. LOAD SECOND CAR.

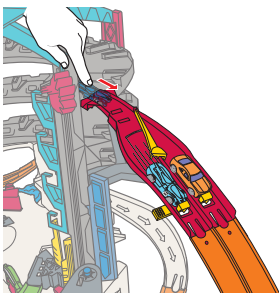

5. PRESS LEVER TO START RACE.

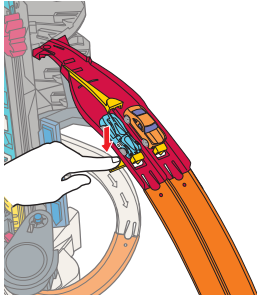

6. POP-UP PANEL DISPLAYS THE WINNING LANE!

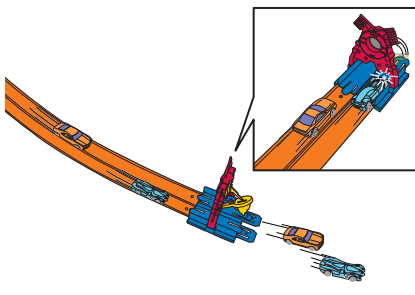

**COLORS AND DECORATIONS MAY VARY.
NOT FOR USE WITH SOME HOT WHEELS® VEHICLES.**

MORE WAYS TO PLAY

CONNECT TO OTHER HOT WHEELS® SETS (SOLD SEPARATELY).

FRONT

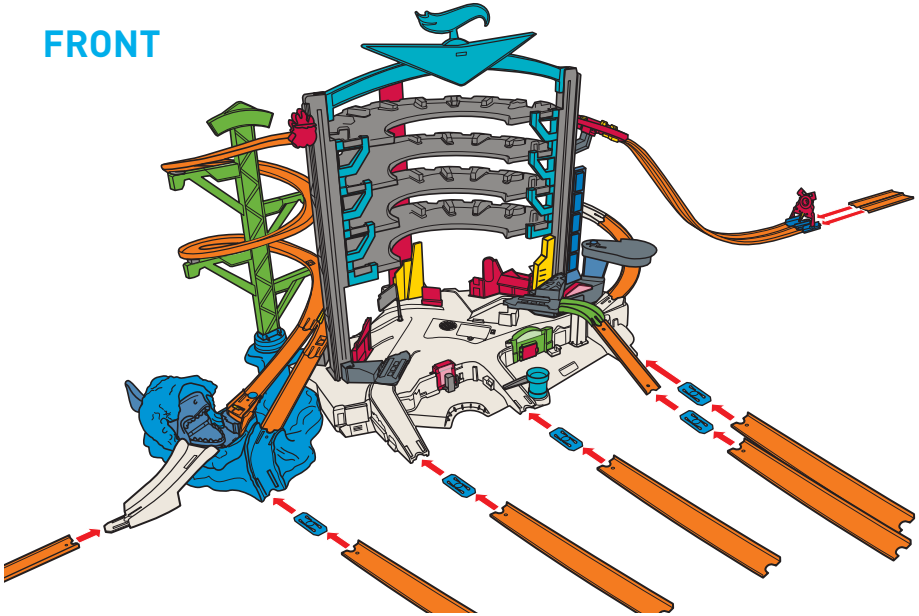

BACK

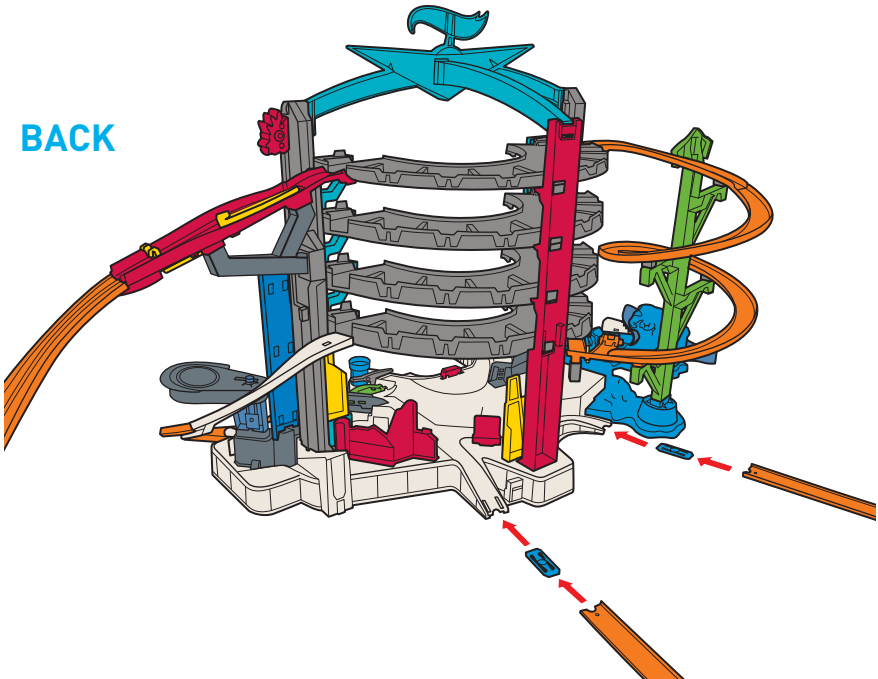

PERFORMANCE TIPS

- Q. My car keeps crashing on the track for no reason. What is the problem?**
- A. Clear all obstructions on the track. Adjust track side walls at each connection point and make sure they are assembled either inside or outside of the track tabs, as described in the assembly steps.**

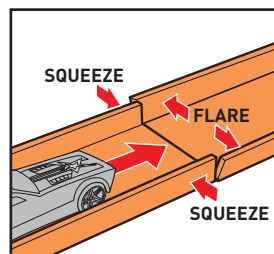

- Q. My car keeps slowing down by itself on the tracks.**
- A. Lint may collect around your car's axles. This may cause the car to run slowly. Use tweezers or a toothpick to remove lint.**

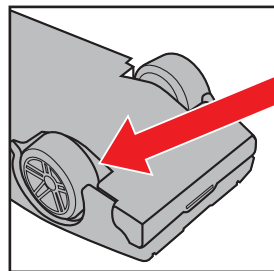

BATTERY SAFETY INFORMATION

In exceptional circumstances batteries may leak fluids that can cause a chemical burn injury or ruin your product. To avoid battery leakage:

- Non-rechargeable batteries are not to be recharged.
- Rechargeable batteries are to be removed from the product before being charged.
- Rechargeable batteries are only to be charged under adult supervision.
- Do not mix alkaline, standard (carbon-zinc), or rechargeable (nickel-cadmium) batteries.
- Do not mix old and new batteries.
- Only batteries of the same or equivalent type as recommended are to be used.
- Batteries are to be inserted with the correct polarity.
- Exhausted batteries are to be removed from the product.
- The supply terminals are not to be short-circuited.
- Dispose of battery(ies) safely.
- Do not dispose of this product in a fire. The batteries inside may explode or leak.



Protect the environment by not disposing of this product with household waste (2002/96/EC). Check your local authority for recycling advice and facilities.