

JVC

KD-X560BT

DIGITAL MEDIA RECEIVER

Quick Start Guide

JVCKENWOOD Corporation

- For detailed operations and information, refer to the INSTRUCTION MANUAL on the following website:

[<http://www.jvc.net/cs/car/>](http://www.jvc.net/cs/car/)



Contents

Before use	2
How to read this manual	2
Precautions	2
Getting Started	3
Initial settings	3
Clock settings	3
Basics	4
Common operations	4
How to attach/detach the faceplate	4
Select a source	4
USB/iPod	5
Preparation	5
Playback operations	5
Tuner	6
Tuner basic operations	6
Tuner function settings	6
External Components	7
Using external audio players	7
Rear view camera	7
Bluetooth® smartphone	8
Register your smartphone to the unit	8
Receive a call	8
Make a phone call	8
Playing Bluetooth Audio Device	8
Setup	9
Settings	9
Sound settings	9
Installation	10
Before installation	10
Installing the unit	11
About this Unit	14
Maintenance	14
Note for specifications	14
Copyrights	14

Before use

Precautions

▲WARNING

■ To prevent injury or fire, take the following precautions:

- To prevent a short circuit, never put or leave any metallic objects (such as coins or metal tools) inside the unit.
- Do not watch or fix your eyes on the unit's display when you are driving for any extended period.
- If you experience problems during installation, consult your JVC dealer.

■ Precautions on using this unit

- When you purchase optional accessories, check with your JVC dealer to make sure that they work with your model and in your area.
- The Radio Data System or Radio Broadcast Data System feature won't work where the service is not supported by any broadcasting station.

■ Protecting the monitor

- To protect the monitor from damage, do not operate the monitor using a ballpoint pen or similar tool with the sharp tip.

■ How to reset your unit

If the unit or the connected unit fails to operate properly, reset the unit.

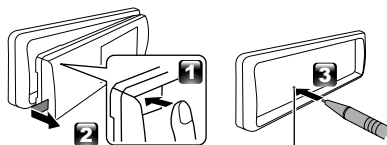

Reset button

How to read this manual

- The panels shown in this guide are examples used to provide clear explanations of the operations. For this reason, they may be different from the actual panels.
- In operation procedures, bracket shape indicates the item you should control.
[]: indicates the selected items or menu.
< >: indicates the name of panel buttons.
- **Display language:** English is used for the purpose of explanation. You can select a display language from the [Language] menu. See **Language (P.9)**.

Getting Started

Initial settings

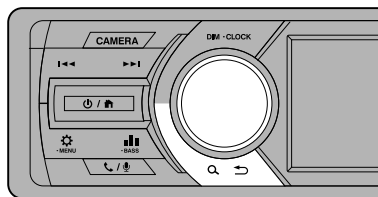

- 1 Turn the ignition key of your car to ACC.
The unit is turned on.
- 2 Turn the volume knob to select the item to set (see the table below), then press the knob to make a selection.

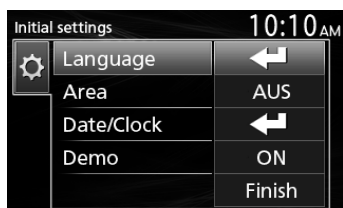

Language

Select the language used for the control screen and setting items. Default is "English".

Area

AUS (Default): For Australia, AM/FM intervals: 9 kHz/50 kHz

ASIA: For Asia, AM/FM intervals: 9 kHz/50 kHz

OTHER: Outside Australia and Asia, AM/FM intervals: 10 kHz/200 kHz.

Date/Clock

Adjust the date, then adjust the time.
Hour / Minute / Month / Day / Year

Demo

Set the demonstration mode. Default is "ON".

- 3 Turn the volume knob to select [Finish], then press the knob.

Clock settings

■ Synchronizing the clock time with FM RDS

Activate [RDS Clock Sync]. See "Tuner function settings" (P.6).

■ Adjusting the clock manually

📎 NOTE

- Deactivate [RDS Clock Sync] before adjusting the clock. See "Tuner function settings" (P.6).

- 1 Press and hold <⚙> to display the settings.
- 2 Press <⏪>/<⏩> to select [⚙].
- 3 Turn the volume knob to select [Time Format], then press the knob to select the time format ([12h] or [24h]).

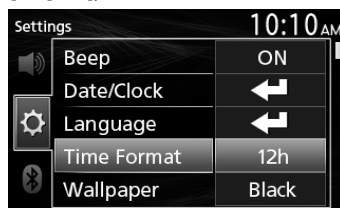

- 4 Turn the volume knob to select [Date/Clock], then press the knob.

Clock screen appears.



- 5 Turn the volume knob to adjust the hour, then press the knob.
- 6 Turn the volume knob to adjust the minute, then press the knob.
- 7 Turn the volume knob to adjust the day, then press the knob.
- 8 Turn the volume knob to adjust the month, then press the knob.
- 9 Turn the volume knob to adjust the year, then press the knob.
- 10 Press <⏪>.

Basics

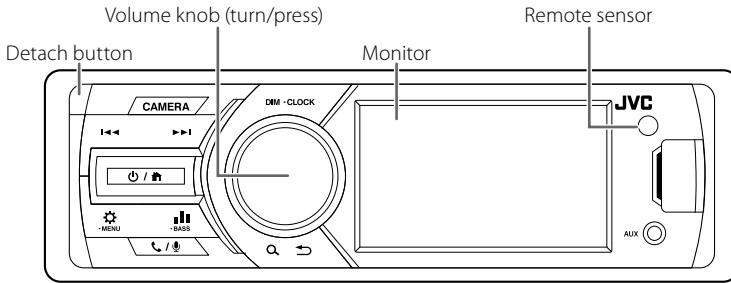

Common operations

Turning on the power

- 1 Press <Power / Home>.

Turning off the power

- 1 Press and hold <Power / Home>.

Adjusting the volume

- 1 Turn the volume knob.

Mutes the sound

- 1 Press and hold the volume knob.
 - A speaker with a slash through it appears when the mute function is active.
 - To restore the sound, press and hold again, or adjust the volume.

Display the clock

- 1 Press and hold the <DIM> button.

Select dimmer mode

- 1 Press the <DIM> button.
 - Dimmer 1, Dimmer 2, Dimmer 3

How to attach/detach the faceplate

Detach

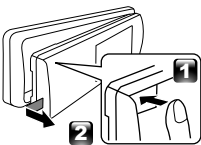

Attach

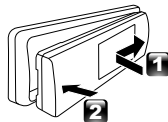

Select a source

- 1 Press <Power / Home> to display the HOME screen. HOME screen appears.
- 2 Turn the volume knob to select the source, then press the knob.

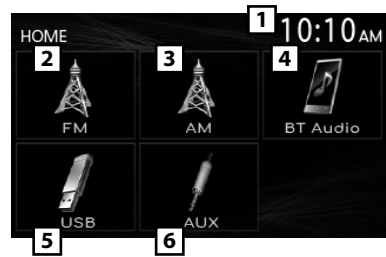

- 1 Clock display
- 2 Switches to the FM tuner broadcast. (P.6)
- 3 Switches to the AM tuner broadcast. (P.6)
- 4 Plays a Bluetooth audio player. (P.8)
- 5 [USB] Plays files on a USB device. (P.5)
- [iPod] Plays an iPod/iPhone. (P.5)
 - When iPod/iPhone is connected.
- 6 Switches to an external component connected to the AUX input terminal. (P.7)

USB/iPod

Preparation

■ Connecting a USB device/iPod/iPhone

- 1 Open the front port cover.
- 2 Connect the USB device with the USB cable (sold separately).

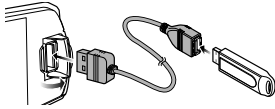

Connect the iPod/iPhone using the KS-U62 (optional accessory).

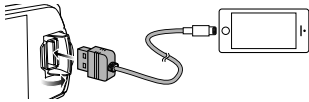

The unit reads the device and playback starts.

- USB maximum power supply current : DC 5 V = 1 A

■ To disconnect the USB device/iPod/iPhone

- 1 Press $\langle \text{Power} \rangle$ / $\langle \text{Home} \rangle$ to display the HOME screen.
- 2 Turn the volume knob to select other than [USB] and [iPod], then press the knob.
- 3 Detach the USB device/iPod/iPhone.

■ Usable USB device

This unit can play MP3/ WMA/ AAC/ WAV/ FLAC/ OGG/ MPEG1/ MPEG2/ MPEG4/ H.264/ MKV/ JPEG/ BMP/ PNG files stored in a USB mass storage class device.

■ Connectable iPod/iPhone

The following models can be connected to this unit.



Made for

- iPhone X
- iPhone SE
- iPhone 5s
- iPhone 8 Plus
- iPhone 6s Plus
- iPod touch (6th generation)
- iPhone 8
- iPhone 6s
- iPhone 7 Plus
- iPhone 6 Plus
- iPhone 7
- iPhone 6

Playback operations

To	Do this
Play/pause	Press the volume knob.
Select a file	Press $\langle \text{Left Arrow} \rangle$ / $\langle \text{Right Arrow} \rangle$ repeatedly.
Fast-backward/ Fast-forward	Press and hold $\langle \text{Left Arrow} \rangle$ / $\langle \text{Right Arrow} \rangle$. • Video files: Each time you press the button, the search speed changes.

■ Selecting a track/content in a list (Searches file)

- 1 Press $\langle \text{Search} \rangle$ $\langle \text{Right Arrow} \rangle$ to display the LIST screen.
- 2 Press $\langle \text{Left Arrow} \rangle$ / $\langle \text{Right Arrow} \rangle$ to select whether you search by audio files [], video files [] or picture files []. (USB only)
- 3 Turn the volume knob to select the desired folder/category, then press the knob.
 - When you select a folder its contents are displayed.
 - To return to the previous layer, press $\langle \text{Search} \rangle$ $\langle \text{Right Arrow} \rangle$.
- 4 Turn the volume knob to select the desired item, then press the knob.
Playback starts.

Tuner

Tuner basic operations

- 1 Press **<⏪ / ⏩>** to display the HOME screen.
- 2 Turn the volume knob to select [FM] or [AM], then press the knob.
- 3 Press **<⏪>/<⏩>** to search for a station automatically.
"Auto Seek" appears.
(or)
Press and hold **<⏪>/<⏩>** repeatedly to search for a station manually.
"Manual Seek" appears.

NOTE

- To store stations, perform [Manual Store] or [Auto Store].

Select a stored station

You can preset 15 stations for FM and 15 stations for AM.

- 1 Press **<🔍 ↶>** to display the LIST screen.
- 2 Turn the volume knob to select a preset number, then press the knob.

NOTE

- To exit, press **<🔍 ↶>**.

Tuner function settings

- 1 Press **<⚙️>** to display the function menu.
- 2 Turn the volume knob to select the item to set (see the table below), then press the knob to make a selection.
- 3 Press **<🔍 ↶>**.

Manual Store	Stores a station manually. While listening to a station you want to store, turn the volume knob to select a preset number, then press the knob.
Auto Store	Automatically searches and stores the 15 stations with the strongest signals for the selected band. • "Auto Store" appears.
Local Seek	Tunes in only to the stations with sufficient signal strength. "ON", "OFF" (Default)
Area	AUS (Default): For Australia, AM/FM intervals: 9 kHz/50 kHz ASIA: For Asia, AM/FM intervals: 9 kHz/50 kHz OTHER: Outside Australia and Asia, AM/FM intervals: 10 kHz/200 kHz.
Mono *1	Determines whether to receive stereo broadcasts in the stereo mode or monaural mode. "ON", "OFF" (Default)
RDS *1	FM Radio Data System features "ON" (Default), "OFF"
PTY *1*2	Searches for a program by program type.
AF *1*2	When station reception is poor, automatically switches to the station that is broadcasting the same program over the same Radio Data System network. "ON" (Default), "OFF"
TA *1*2	Switches to the traffic information automatically when the traffic bulletin starts. (TI indicator lights up.) "ON", "OFF" (Default)
RDS Clock Sync *1*2	Synchronizing the Radio Data System station time data and this unit's clock. "ON" (Default), "OFF"

*1 FM only

*2 Available when [RDS] is set to [ON].

External Components

Using external audio players

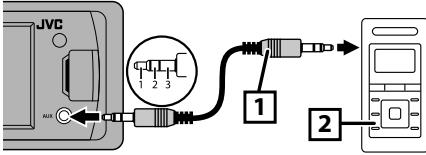

- 1 3.5 mm stereo mini plug (Sold separately)
Use a 3-core plug head stereo mini plug for optimum audio output.
- 2 Portable audio player (Sold separately)

Starting playback

- 1 Connect an external component to the AUX input terminal.
- 2 Press **<⏻ / 🏠>** to display the HOME screen.
- 3 Turn the volume knob to select [AUX], then press the knob.
- 4 Turn on the connected component and start playing the source.

Rear view camera

To use a rear view camera, the REVERSE lead connection is required. For connecting a rear view camera. (P.12)

Displaying the picture from the rear view camera

The rear view screen is displayed when you shift the gear to the reverse (R) position.



To display the picture from the rear view camera manually

- 1 Press **<CAMERA>**.

Bluetooth® smartphone

Register your smartphone to the unit

You can use your Bluetooth smartphone when paired to this unit.

- You can pair the device and the unit using SSP (Secure Simple Pairing) which only requires confirmation.
- One device can be connected at a time.
- When you register a new Bluetooth device, disconnect the Bluetooth device currently connected and then register the new device.

1 Turn on the Bluetooth function on your smartphone/cell-phone.

2 Search the unit ("KD-X56*") from your smartphone/cell-phone.

If a PIN code is required, enter the PIN code ("0000").

■ Disconnecting the device

- Turn off the Bluetooth function from your smartphone/cell-phone.
- Turn off the ignition switch.

■ About smartphone compatible with Phone book Access Profile (PBAP)

If your smartphone supports PBAP, you can display the following items when the smartphone is connected.

- Phone book
- Dialed calls, received calls, and missed calls

Receive a call

To	Do this
Answer a call	Press <📞 / 📞>.

■ Operations during a call

To	Do this
End a call	Press <📞 / 📞>.

Adjust the phone volume Turn the volume knob.

Switching between hands-free mode and phone mode Press <📞 ↺>. Each time you press the button, "Transfer!" appears and talking method is switched between hands-free mode and phone mode.

Make a phone call

1 Press <📞 / 📞> to enter Bluetooth mode.



2 Press <⏪>/<⏩> to select a method to make a call ([📞]: from the calls history/[📞]: from the phone book).

3 Turn the volume knob to select the target, then press the knob to make a call.

Playing Bluetooth Audio Device

1 Press <🏠 / 🏠> to display the HOME screen.

2 Turn the volume knob to select [BT Audio], then press the knob.

To	Do this
Play/pause	Press the volume knob.
Select a file	Press <⏪>/<⏩> repeatedly.
Fast-backward/ Fast-forward	Press and hold <⏪>/<⏩>.

🔗 NOTE

- Operations and display indications may differ according to their availability on the connected device.

■ Selecting a content in a list





1 Press <🔍 ↺> to display the LIST screen.

2 Turn the volume knob to select an item, then press the knob.

- To return to the previous layer, press <🔍 ↺>.

Setup

Settings

- 1 Press and hold  to display the settings.
- 2 Press / to select the category.
- 3 Turn the volume knob to select an item (see the following table), then press the knob.
- 4 Repeat step 3 until the desired item is selected/activated or follow the instructions stated on the selected item.
- 5 Press .

Audio Settings

Fader	R12 — F12 (00): Adjusts the front and rear speaker output balance.
Balance	L12 — R12 (00): Adjusts the left and right speaker output balance.



General Settings

Beep	ON/OFF: Activates or deactivates the keypress tone. Default is "ON".
Date/Clock	Adjusts the date and clock. (P.3)
Language	Selects the text language used for on-screen information.
Time Format	12h/24h: Selects time format. Default is "12h".
Wallpaper	Black/Blue: Selects the wallpaper image.
Demo	Set the demonstration mode. Default is "ON".
Initialize	Select [Initialize] and then select [Yes] to set all the settings to the initial default settings.

Bluetooth Settings

Sync Phonebook	ON/OFF: Activates or deactivates the synchronization of the phonebook in the connected smartphone with the unit.
BT Information	Displays the information about the connected Bluetooth device (device name, phone name, and mac address).

Sound settings

- 1 Press  to display the sound setting.
- 2 Turn the volume knob to select an item (see the following table), then press the knob.
- 3 Repeat step 2 until the desired item is selected/activated or follow the instructions stated on the selected item.
- 4 Press .



Graphic Equalizer Selects a preset equalizer suitable to the music genre.
Flat / DRVN / Hard Rock / Hip Hop / Jazz / Pop/ R & B / User / Classical

Select [User] to use the settings made



- 1) Press the volume knob to select the frequency.
- 2) Turn the volume knob to adjust the level.
- 3) Press .

Loudness Sets the amounts of boost of low and high tones.
"ON", "OFF" (Default)

X'over You can set the crossover frequency of speakers.

- 1) Press / to select the speaker.
- 2) Press the volume knob to select the item.
- 3) Turn the volume knob to adjust the value.
- 4) Press .

Delay Adjust the sound delay time so that the sounds from different speakers arrive at the listener sitting on the selected seat at the same time.

- 1) Press / to select the speaker.
- 2) Turn the volume knob to adjust the value.
- 3) Press .

Installation

Before installation

Before installation of this unit, please note the following precautions.

▲WARNINGS

- If you connect the ignition wire (red) and the battery wire (yellow) to the car chassis (ground), you may cause a short circuit, that in turn may start a fire. Always connect those wires to the power source running through the fuse box.
- Do not cut out the fuse from the ignition wire (red) and the battery wire (yellow). The power supply must be connected to the wires via the fuse.

▲CAUTION

- Install this unit in the console of your vehicle. Do not touch the metal part of this unit during and shortly after the use of the unit. Metal part such as the heat sink and enclosure become hot.







🔧 NOTE

- Mounting and wiring this product requires skills and experience. For best safety, leave the mounting and wiring work to professionals.
- Make sure to ground the unit to a negative 12V DC power supply.
- Do not install the unit in a spot exposed to direct sunlight or excessive heat or humidity. Also avoid places with too much dust or the possibility of water splashing.
- Do not use your own screws. Use only the screws provided. If you use the wrong screws, you could damage the unit.
- If your car's ignition does not have an ACC position, connect the ignition wires to a power source that can be turned on and off with the ignition key. If you connect the ignition wire to a power source with a constant voltage supply, such as with battery wires, the battery may be drained.
- If the console has a lid, make sure to install the unit so that the front panel will not hit the lid when closing and opening.
- If the fuse blows, first make sure the wires aren't touching to cause a short circuit, then replace the old fuse with one with the same rating.
- Insulate unconnected wires with vinyl tape or other similar material. To prevent a short circuit, do not remove the caps on the ends of the unconnected wires or the terminals.
- Secure the wires with cable clamps and wrap vinyl tape around the wires that comes into contact with metal parts to protect the wires and to prevent short circuit.

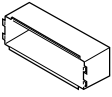
- Connect the speaker wires correctly to the terminals to which they correspond. The unit may be damaged or fail to work if you share the ⊖ wires or ground them to any metal part in the car.
- When only two speakers are being connected to the system, connect the connectors either to both the front output terminals or to both the rear output terminals (do not mix front and rear). For example, if you connect the ⊕ connector of the left speaker to a front output terminal, do not connect the ⊖ connector to a rear output terminal.
- After the unit is installed, check whether the brake lamps, blinkers, wipers, etc. on the car are working properly.
- Mount the unit so that the mounting angle is 30° or less.
- Do not press hard on the panel surface when installing the unit to the vehicle. Otherwise scars, damage, or failure may result.
- Reception may drop if there are metal objects near the Bluetooth antenna.



■ Supplied accessories for installation

①		x1	②		x1
③		x2	④		x1
⑤		x1	⑥		x1
⑦		x1			

Installation

Installation procedure

- 1) To prevent a short circuit, remove the key from the ignition and disconnect the ⊖ terminal of the battery.
- 2) Make the proper input and output wire connections for each unit.
- 3) Connect the wire on the wiring harness.
- 4) Take Connector B on the wiring harness and connect it to the speaker connector in your vehicle.
- 5) Take Connector A on the wiring harness and connect it to the external power connector on your vehicle.
- 6) Connect the wiring harness connector to the unit.
- 7) Install the unit in your car.
- 8) Reconnect the ⊖ terminal of the battery.
- 9) Press the reset button.

Installing the unit

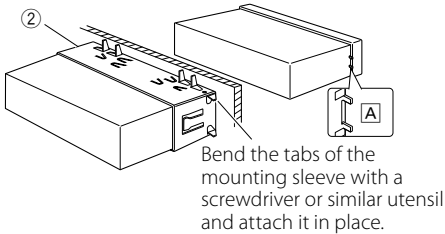

NOTE

- Make sure that the unit is installed securely in place. If the unit is unstable, it may malfunction (eg, the sound may skip).
- If the panel opening of your vehicle is too small to fit the unit (A), trim (the upper and lower sides and right and left sides of) panel opening.

Trim plate

- 1) Attach accessory ① to the unit.

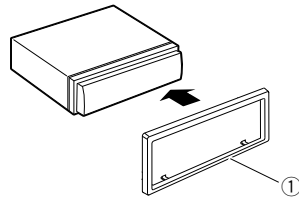

Microphone unit

- 1) Check the installation position of the microphone (accessory ⑤).
- 2) Clean the installation surface.
- 3) Remove the separator of the microphone (accessory ⑤), and stick the microphone to the place shown below.
- 4) Wire the microphone cable up to the unit with it secured at several positions using tape or other desired method.
- 5) Adjust the direction of the microphone (accessory ⑤) to the driver.

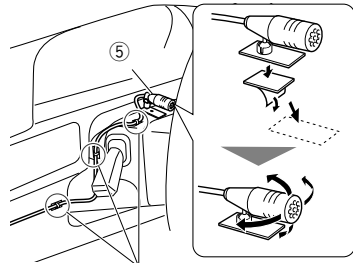

Fix a cable with a commercial item of tape.

NOTE

- Use the clips if necessary.

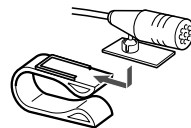

Installation

■ Removing the trim plate

- 1) Use the extraction key (accessory ④) to lever out the four tabs (two on the top part, two on the bottom part).

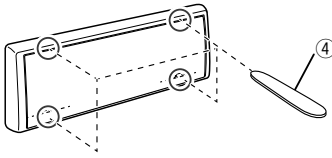

- 2) Pull the trim plate forward.

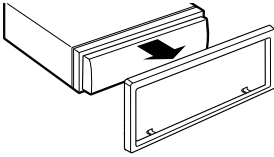

■ Removing the unit

- 1) Remove the trim plate by referring to step 1 in "Removing the trim plate".
- 2) Detach the faceplate.

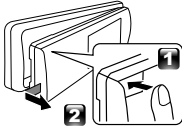

- 3) Insert the two extraction keys (accessory ③) deeply into the slots on each side, as shown.

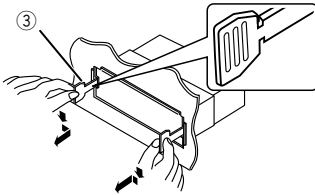

- 4) Lower the removal tool toward the bottom, and pull out the unit halfway while pressing towards the inside.

NOTE

- Be careful to avoid injury from the catch pins on the extraction key.
- 5) Pull the unit all the way out with your hands, being careful not to drop it.

■ Connecting wires to terminals

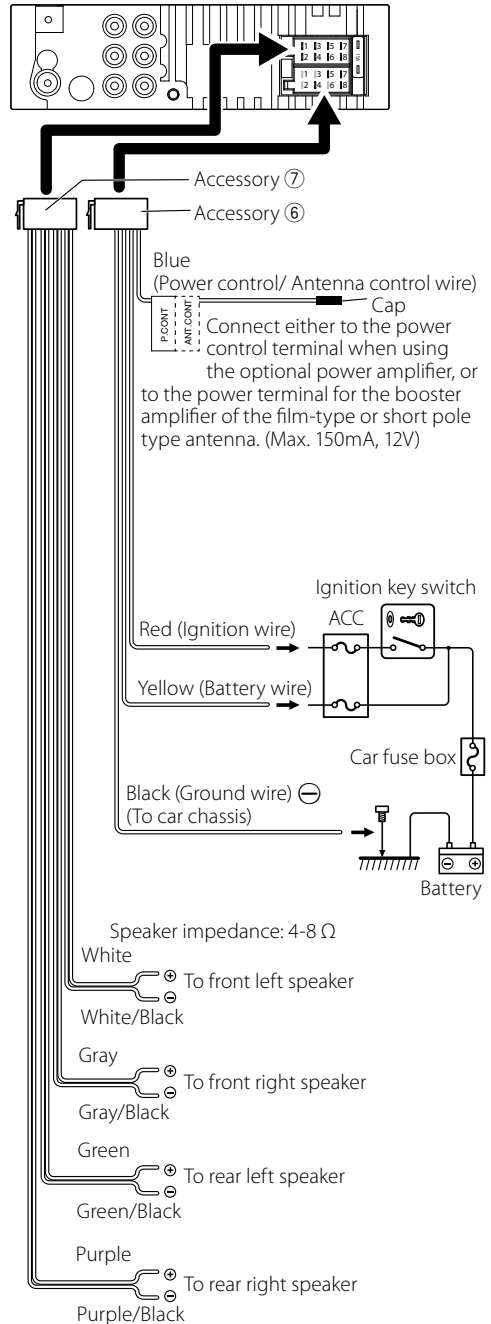

Installation

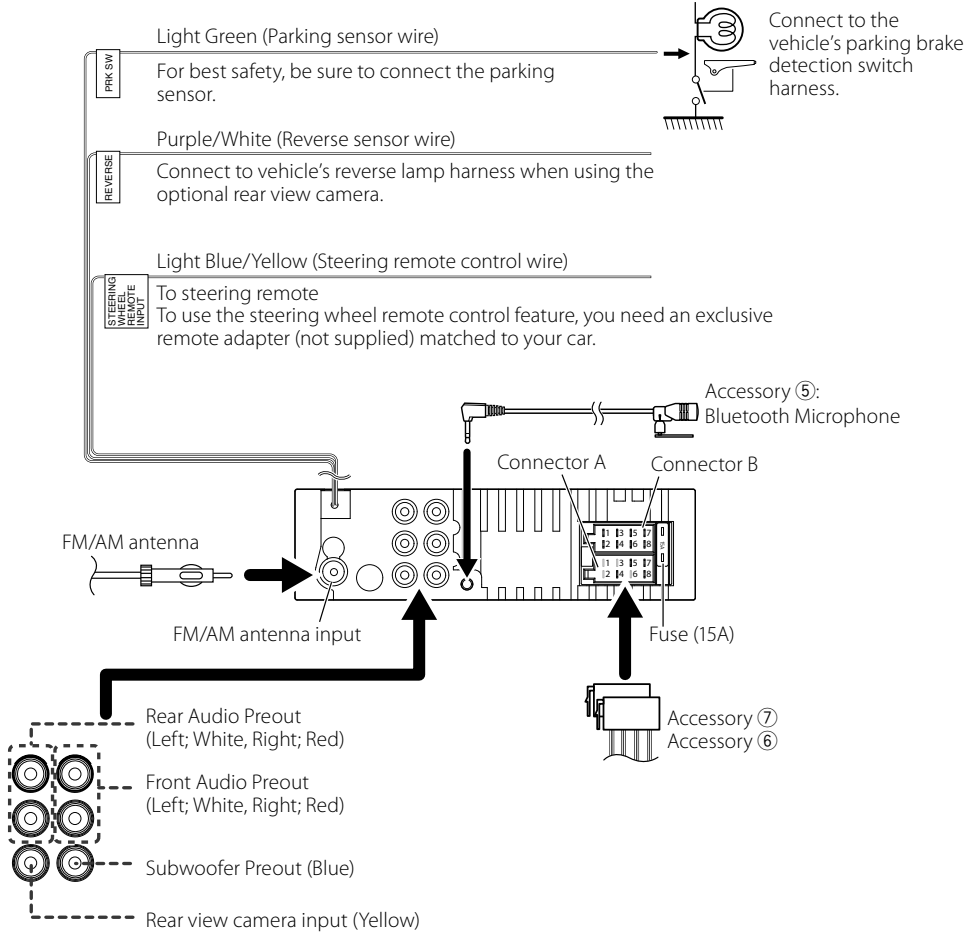

About this Unit

Maintenance

Cleaning the Unit

If the front panel of this unit is stained, wipe it with a dry soft cloth such as a silicon cloth. If the front panel is stained badly, wipe the stain off with a cloth moistened with neutral cleaner, then wipe it again with a clean soft dry cloth.

CAUTION

- Applying spray cleaner directly to the unit may affect its mechanical parts. Wiping the front panel with a hard cloth or using a volatile liquid such as thinner or alcohol may scratch the surface or erase screened print.

Cleaning the connector

Detach the faceplate and clean the connector gently with a cotton swab. Be careful not to damage the connector.



Connector (on the reverse side of the faceplate)

Note for specifications

Bluetooth section

Frequency

: 2.402 – 2.480 GHz

Output Power

: +8 dBm (AVE), Power Class1

General

Speaker Impedance

: 4 – 8 Ω

Operating Voltage

: 12 V DC car battery

Copyrights

- The Bluetooth word mark and logos are registered trademarks owned by the Bluetooth SIG, Inc. and any use of such marks by JVC KENWOOD Corporation is under license. Other trademarks and trade names are those of their respective owners.
- Use of the Made for Apple badge means that an accessory has been designed to connect specifically to the Apple product(s) identified in the badge, and has been certified by the developer to meet Apple performance standards. Apple is not responsible for the operation of this device or its compliance with safety and regulatory standards. Please note that the use of this accessory with an Apple product may affect wireless performance.
- Apple, iPhone, iPod, iPod touch, and Lightning are trademarks of Apple Inc., registered in the U.S. and other countries.
- Microsoft and Windows Media are either registered trademarks or trademarks of Microsoft Corporation in the United States and/or other countries.
- THIS PRODUCT IS LICENSED UNDER THE MPEG-4 VISUAL PATENT PORTFOLIO LICENSE FOR THE PERSONAL AND NON-COMMERCIAL USE OF A CONSUMER FOR (i) ENCODING VIDEO IN COMPLIANCE WITH THE MPEG-4 VISUAL STANDARD ("MPEG-4 VIDEO") AND/OR (ii) DECODING MPEG-4 VIDEO THAT WAS ENCODED BY A CONSUMER ENGAGED IN A PERSONAL AND NON-COMMERCIAL ACTIVITY AND/OR WAS OBTAINED FROM A VIDEO PROVIDER LICENSED BY MPEG LA TO PROVIDE MPEG-4 VIDEO. NO LICENSE IS GRANTED OR SHALL BE IMPLIED FOR ANY OTHER USE. ADDITIONAL INFORMATION INCLUDING THAT RELATING TO PROMOTIONAL, INTERNAL AND COMMERCIAL USES AND LICENSING MAY BE OBTAINED FROM MPEG LA, LLC. SEE [HTTP://WWW.MPEGLA.COM](http://www.mpegla.com).
- THIS PRODUCT IS LICENSED UNDER THE AVC PATENT PORTFOLIO LICENSE FOR THE PERSONAL USE OF A CONSUMER OR OTHER USES IN WHICH IT DOES NOT RECEIVE REMUNERATION TO (i) ENCODE VIDEO IN COMPLIANCE WITH THE AVC STANDARD ("AVC VIDEO") AND/OR (ii) DECODE AVC VIDEO THAT WAS ENCODED BY A CONSUMER ENGAGED IN A PERSONAL ACTIVITY AND/OR WAS OBTAINED FROM A VIDEO PROVIDER LICENSED TO PROVIDE AVC VIDEO. NO LICENSE IS GRANTED OR SHALL BE IMPLIED FOR ANY OTHER USE. ADDITIONAL INFORMATION MAY BE OBTAINED FROM MPEG LA, L.L.C. SEE [HTTP://WWW.MPEGLA.COM](http://www.mpegla.com)

About this Unit

- libFLAC
Copyright (C) 2000-2009 Josh Coalson
Copyright (C) 2011-2013 Xiph.Org Foundation
 - Redistribution and use in source and binary forms, with or without modification, are permitted provided that the following conditions are met:
 - Redistributions of source code must retain the above copyright notice, this list of conditions and the following disclaimer.
 - Redistributions in binary form must reproduce the above copyright notice, this list of conditions and the following disclaimer in the documentation and/or other materials provided with the distribution.

Neither the name of the Xiph.org Foundation nor the names of its contributors may be used to endorse or promote products derived from this software without specific prior written permission.

THIS SOFTWARE IS PROVIDED BY THE COPYRIGHT HOLDERS AND CONTRIBUTORS "AS IS" AND ANY EXPRESS OR IMPLIED WARRANTIES, INCLUDING, BUT NOT LIMITED TO, THE IMPLIED WARRANTIES OF MERCHANTABILITY AND FITNESS FOR A PARTICULAR PURPOSE ARE DISCLAIMED. IN NO EVENT SHALL THE FOUNDATION OR CONTRIBUTORS BE LIABLE FOR ANY DIRECT, INDIRECT, INCIDENTAL, SPECIAL, EXEMPLARY, OR CONSEQUENTIAL DAMAGES (INCLUDING, BUT NOT LIMITED TO, PROCUREMENT OF SUBSTITUTE GOODS OR SERVICES; LOSS OF USE, DATA, OR PROFITS; OR BUSINESS INTERRUPTION) HOWEVER CAUSED AND ON ANY THEORY OF LIABILITY, WHETHER IN CONTRACT, STRICT LIABILITY, OR TORT (INCLUDING NEGLIGENCE OR OTHERWISE) ARISING IN ANY WAY OUT OF THE USE OF THIS SOFTWARE, EVEN IF ADVISED OF THE POSSIBILITY OF SUCH DAMAGE.

- libogg
Copyright (c) 2002, Xiph.org Foundation
Redistribution and use in source and binary forms, with or without modification, are permitted provided that the following conditions are met:
 - Redistributions of source code must retain the above copyright notice, this list of conditions and the following disclaimer.
 - Redistributions in binary form must reproduce the above copyright notice, this list of conditions and the following disclaimer in the documentation and/or other materials provided with the distribution.
 - Neither the name of the Xiph.org Foundation nor the names of its contributors may be used to endorse or promote products derived from this software without specific prior written permission.

THIS SOFTWARE IS PROVIDED BY THE COPYRIGHT HOLDERS AND CONTRIBUTORS "AS IS" AND ANY EXPRESS OR IMPLIED WARRANTIES, INCLUDING, BUT NOT LIMITED TO, THE IMPLIED WARRANTIES OF MERCHANTABILITY AND FITNESS FOR A PARTICULAR PURPOSE ARE DISCLAIMED. IN NO EVENT SHALL THE FOUNDATION OR CONTRIBUTORS BE LIABLE FOR ANY DIRECT, INDIRECT, INCIDENTAL, SPECIAL, EXEMPLARY, OR CONSEQUENTIAL DAMAGES (INCLUDING, BUT NOT LIMITED TO, PROCUREMENT OF SUBSTITUTE GOODS OR SERVICES; LOSS OF USE, DATA, OR PROFITS; OR BUSINESS INTERRUPTION) HOWEVER CAUSED AND ON ANY THEORY OF LIABILITY, WHETHER IN CONTRACT, STRICT LIABILITY, OR TORT (INCLUDING NEGLIGENCE OR OTHERWISE) ARISING IN ANY WAY OUT OF THE USE OF THIS SOFTWARE, EVEN IF ADVISED OF THE POSSIBILITY OF SUCH DAMAGE.

JVC