

EN

Operating instructions

Built-in refrigerators

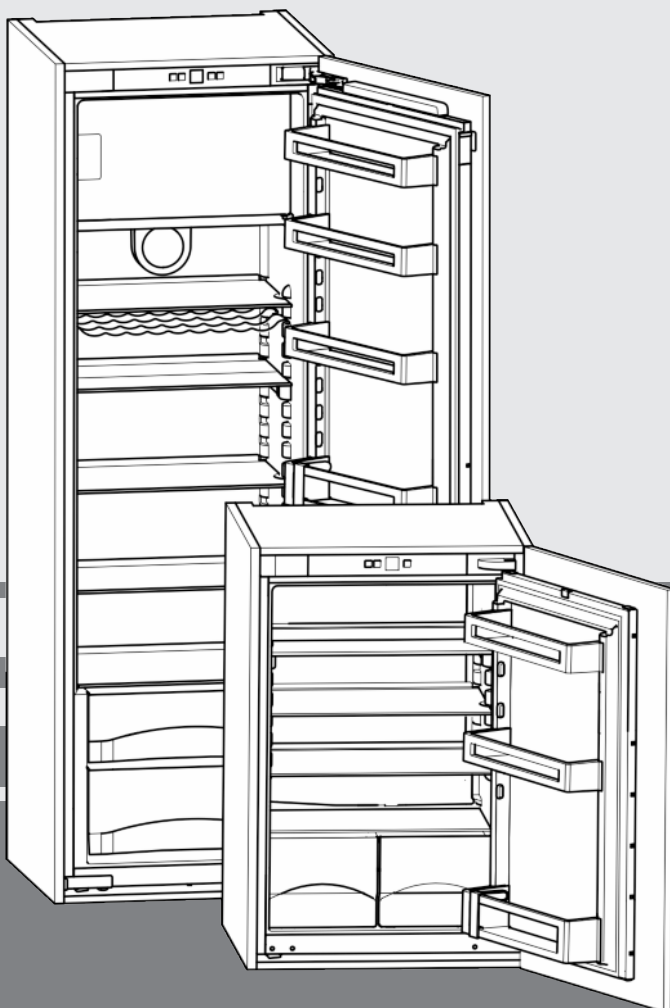

190916 **7086508 - 00**

IK(P)/ IKS/ EK ... LC

LIEBHERR

Contents

1	Appliance at a glance	2
1.1	Description of appliance and equipment.....	2
1.2	Appliance range of use.....	2
1.3	Conformity.....	3
1.4	Saving energy.....	3
2	General safety information	3
3	Controls and displays	4
3.1	Operating and control elements.....	4
3.2	Temperature display.....	4
4	Putting into operation	5
4.1	Switching on the appliance.....	5
5	Control	5
5.1	Child proofing.....	5
5.2	Refrigerator compartment.....	5
5.3	Freezer compartment.....	7
6	Maintenance	8
6.1	Defrosting.....	8
6.2	Cleaning the appliance.....	8
6.3	Customer service.....	9
7	Malfunctions	9
8	Decommissioning	10
8.1	Switching off the appliance.....	10
8.2	Taking the appliance out of service.....	10
9	Disposing of the appliance	10

The manufacturer works constantly on the further development of all the types and models. Therefore please understand that we have to reserve the right to make design, equipment and technical modifications.

To get to know all the benefits of your new appliance, please read the information contained in these instructions carefully.

The instructions apply to several models. Differences may occur. Text relating only to specific appliances is marked with an asterisk (*).

Instructions for action are marked with a ►, the results of action are marked with a ▷.

1 Appliance at a glance

1.1 Description of appliance and equipment

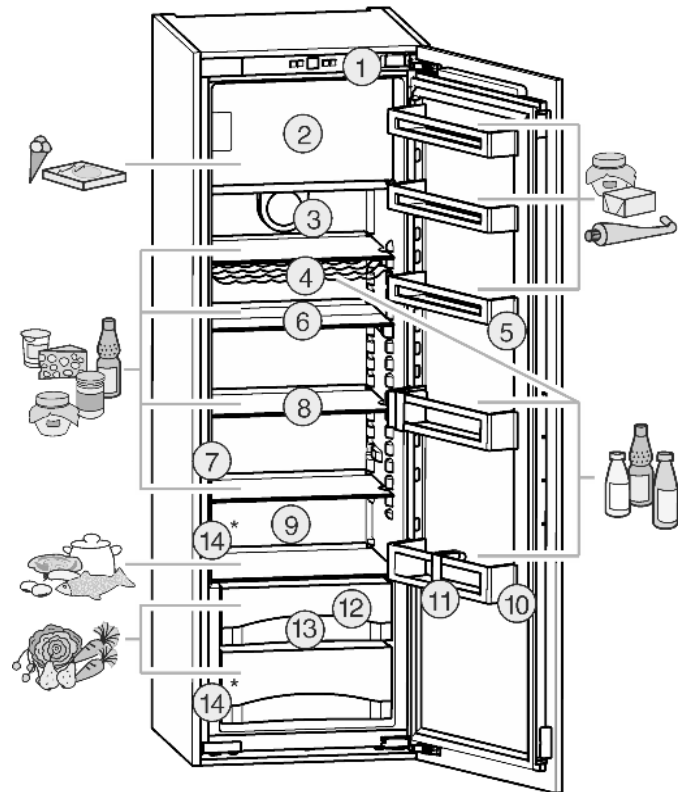

Fig. 1

- | | |
|------------------------------------|-----------------------------|
| (1) Operating and control elements | (9) Coldest zone ** |
| (2) Freezer compartment* | (10) Bottle rack |
| (3) Fan* | (11) Bottle holder* |
| (4) Bottle shelf* | (12) BioCool* |
| (5) Can rack | (12) Vegetable compartment* |
| (6) Shelf, sectioned* | (13) Drain hole |
| (7) LED interior light | (14) Type plate |
| (8) Shelf | |

Note

- Sort foodstuffs as shown in the illustration. This enables the appliance to work in an energy-saving manner.
- Trays, retractable shelves or baskets are arranged ex-factory with optimum energy efficiency in mind.
- ** On appliances with a freezer compartment, the coldest zone is located beneath the freezer compartment whenever the fan is running.

1.2 Appliance range of use

Intended use

The appliance is only suitable for cooling food products in a domestic or household-like environment. This includes, for example, use:

- in staff kitchens, bed and breakfast establishments,
- by guests in country houses, hotels, motels and other accommodation,

- for catering and similar services in the wholesale trade.

All other types of use are not permitted.

Foreseeable misuse

The following applications are expressly forbidden:

- Storing and refrigerating medicines, blood plasma, laboratory preparations or similar substances and products based on the Medical Device Directive 2007/47/EC
- Use in areas at risk of explosions

Misusing the appliance may lead to damage to the goods stored or they may spoil.

Climate classifications

Depending on the climate classification the appliance is designed to operate in restricted ambient temperatures. The climate classification applying to your appliance is printed on the rating plate.

Note

- Keep to the specified ambient temperatures in order to guarantee that the appliance works properly.

Climate classification	for ambient temperatures of
SN	10 °C to 32 °C
N	16 °C to 32 °C
ST	16 °C to 38 °C
T	16 °C to 43 °C

1.3 Conformity

The refrigerant circuit has been tested for leaks. In installed condition, this appliance complies with the applicable safety stipulations and with directives 2014/35/EU, 2014/30/EU, 2009/125/EG, 2011/65/EU and 2010/30/EU.

1.4 Saving energy

- Pay attention to good ventilation. Do not cover ventilation holes or grids.
- Always keep the fan air slits clear.*
- Do not install the appliance in direct sunlight, next to an oven, radiator or similar.
- Energy consumption is dependent on the installation conditions, e.g. ambient temperature (see 1.2) . If the ambient temperature deviates from the standard temperature of 25°C, the energy consumption may differ.
- Open the appliance for as short a time as possible.
- The lower the temperature is set the higher the energy consumption.
- Arrange the food in an organised way (see Appliance at a glance).
- Keep all food properly packed and covered. This prevents frost from forming.
- Only take food out for as long as necessary so that it doesn't warm up too much.
- Inserting warm food: allow to cool down to room temperature first.

- Thaw frozen food in the refrigerator.*
- If there is a thick layer of frost in the appliance: defrost the appliance.*

2 General safety information

Danger for the user:

- This appliance can be used by children from the age of 8 onwards. It can also be used by people with impaired physical, sensory or mental abilities or with a lack of experience and knowledge provided that they are supervised or have received instruction in the safe use of this appliance, and about the attendant hazards. Children must not play with this appliance. Cleaning and user maintenance work must not be carried out by children without adult supervision. Children aged between 3 and 8 are allowed to load and unload the appliance. Children below the age of 3 must be kept away from the appliance unless they are under continuous adult supervision.
- When disconnecting the appliance from the supply, always take hold of the plug. Do not pull the cable.
- In the event of a fault pull out the mains plug or deactivate the fuse.
- Do not damage the mains power cable. Do not operate the appliance with a defective mains power cable.
- Have any repairs to or intervention in the appliance, and any change of the mains power cable, carried out by the customer service only or by other specialised personnel trained for the purpose.
- Only install, connect and dispose of the appliance according to the instructions.
- Only use the appliance when it is installed.
- Please keep these instructions in a safe place and pass them on to any subsequent owners.
- Special-purpose lamps (incandescent lamps, LEDs, fluorescent tubes) in the appliance serve to illuminate the appliance interior and are not suited for room illumination.

Fire hazard:

- Refrigerant R 600a is environmentally friendly, but flammable. Leaking refrigerant may ignite.
 - Do not damage the refrigerant circuit pipes.
 - Do not use an open flame or other source of ignition inside the appliance.
 - Do not use electrical appliances inside the appliance (e.g. steam cleaners, heaters, ice cream makers, etc.).
 - If the refrigerant leaks: remove any naked flames or ignition sources from the vicinity

Controls and displays

of the leakage point. Properly air the room. Inform customer services.

- Do not store explosives or sprays using combustible propellants such as butane, propane, pentane, etc. in the appliance. To identify these spray cans, look for the list of contents printed on the can, or a flame symbol. Gases possibly escaping may ignite due to electrical components.
- Please be sure to store alcoholic drinks or other packaging containing alcohol in tightly closed containers. Any alcohol that leaks out may be ignited by electrical components.

Danger of tipping and falling:

- Do not misuse the plinth, drawers, doors etc. as a step or for support. This applies particularly to children.

Danger of food poisoning:

- Do not consume food which has been stored too long.

Danger of frostbite, numbness and pain:

- Avoid lasting skin contact with cold surfaces or refrigerated/frozen food or take protective steps, e.g. wear gloves. Do not consume ice cream, water ice or ice cubes immediately and do not consume them too cold.

Danger of injury and damage:

- Hot steam can lead to injury. Do not use electrical heating or steam cleaning equipment, open flames or defrosting sprays to defrost.
- Do not use sharp implements to remove the ice.

Danger of crushing:

- Do not hold the hinge when opening and closing the door. Fingers may get caught.

Symbols on the appliance:



The symbol can be located on the compressor. It refers to the oil in the compressor and indicates the following danger: Swallowing or inhaling can be fatal. This is only relevant for recycling. There is no danger in normal operation.

Please observe the specific information in the other sections:

	DANGER	identifies a situation involving direct danger which, if not obviated, may result in death or severe bodily injury.
	WARNING	identifies a dangerous situation which, if not obviated, may result in death or severe bodily injury.
	CAUTION	identifies a dangerous situation which, if not obviated, may result in minor or medium bodily injury.

	NOTICE	identifies a dangerous situation which, if not obviated, may result in damage to property.
	Note	identifies useful information and tips.

3 Controls and displays

3.1 Operating and control elements

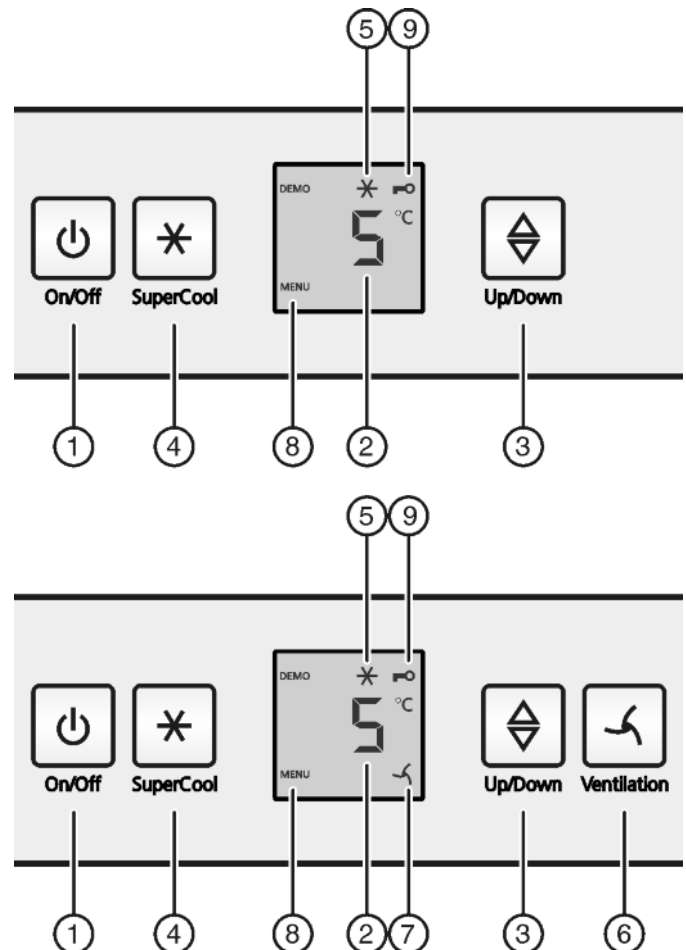

Fig. 2

- (1) On/Off button
- (2) Temperature display
- (3) Setting button
- (4) SuperCool button
- (5) SuperCool symbol
- (6) Ventilation button*
- (7) Ventilation symbol*
- (8) Menu symbol
- (9) Child lock symbol

3.2 Temperature display

During normal operation, the display shows:

- the chiller temperature setting

The following displays indicate a fault. Possible causes and solutions: (see Malfunction).

- F0 to F9

4 Putting into operation

4.1 Switching on the appliance

- ▶ Open the door.
- ▶ Press the On/Off button *Fig. 2 (1)*.
- ▷ The temperature display lights up. The interior light goes on when the door is opened. The appliance is switched on.
- ▷ If "DEMO" is displayed, demo mode is activated. Please contact the after sales service.



5 Control

5.1 Child proofing

The child-proofing function enables you to make sure that the appliance is not inadvertently switched off by playing children.



5.1.1 Setting the child lock

To activate the setting mode:

- ▶ Press the SuperCool button *Fig. 2 (4)* for about 5 seconds.
- ▷ The Menu symbol is shown on the display, *Fig. 2 (8)*.
- ▷ **c** flashes on the display.

To switch on the function:

- ▶ Confirm briefly with the SuperCool button *Fig. 2 (4)*.
- ▷ **cl** appears on the display.
- ▶ Confirm briefly with the SuperCool button *Fig. 2 (4)*.
- ▷ The child lock symbol, *Fig. 2 (9)*, lights up on the display.
- ▷ **c** flashes on the display.
- ▷ The child lock function is switched on.



If the function is to be switched off:

- ▶ Confirm briefly with the SuperCool button *Fig. 2 (4)*.
- ▷ **c0** appears on the display.
- ▶ Confirm briefly with the SuperCool button *Fig. 2 (4)*.
- ▷ **c** flashes in the display.
- ▷ The child lock function is switched off.



To end the setting mode:

- ▶ Briefly press the On/Off button *Fig. 2 (1)*.
- ▷ The temperature display shows the temperature again.

5.2 Refrigerator compartment

The natural circulation of air in the refrigerator compartment results in zones differing in temperature. It is coldest directly above the vegetable drawers and at the rear wall. It is warmest at the top front of the compartment and in the door.

5.2.1 Food refrigeration

Note*

The energy consumption increases and the cooling performance decreases if the ventilation is inadequate.

- ▶ Always keep the air slits of the fan free.

- ▶ Store perishable food such as ready-to-serve dishes, meat products and sausages in the coldest zone. Place butter and preserves in the upper area and in the door (see Appliance at a glance).
- ▶ Use recyclable plastic, metal, aluminium and glass containers and cling film for wrapping.

- ▶ Always store liquids and food which is subject to odour or taste transfer in closed containers or cover them.
- ▶ Foods which give off a large amount of ethylene gas and delicate foods, such as fruit, vegetables, salad, should always be stored separately or wrapped so as not to reduce the storage life; e.g. do not store tomatoes together with kiwis or cabbage.

for appliances from 1218 mm in height, the following applies:

- ▶ Use the front area of the refrigerator compartment floor only for briefly putting down cooled products, e.g. when rearranging and sorting. However do not leave cooled products there otherwise they may be pushed back or tipped over when the door is closed.
- ▶ Do not store food too close together to enable good air circulation.

5.2.2 Setting the temperature

The temperature depends on the following factors:

- the frequency of opening the door
- the room temperature of the installation location
- the type, temperature and quantity of the food

Recommended temperature setting: 5 °C

An average temperature of approx. -18 °C is then established in the freezer compartment.*

The temperature can be adjusted continually. Once the 1 °C setting is reached, the sequence starts again at 9 °C.

- ▶ Call up temperature function: press the setting button *Fig. 2 (3)*.

- ▷ The previously-set value will flash in the temperature display.

- ▶ Change the temperature in 1 °C steps: Press the setting button *Fig. 2 (3)* until the required temperature is indicated in the temperature display.

- ▶ Change temperature continually: hold down setting button.

- ▷ During adjustment the value flashes on the display.

- ▷ The new setting is adopted approx. 5 seconds after the last time the button was pressed and the set temperature displayed again. The temperature in the interior gradually adjusts to the new value.



5.2.3 SuperCool

With SuperCool you switch to the highest cooling performance to reach lower cooling temperatures. Use SuperCool, to rapidly cool large amounts of food.



When SuperCool is activated, the fan* may run. The appliance operates with maximum cooling performance, which means that the noise of the refrigeration unit may be temporarily louder.

The SuperCool function uses slightly more energy.

Cooling with SuperCool

- ▶ Briefly press SuperCool button *Fig. 2 (4)*.
- ▷ The SuperCool symbol *Fig. 2 (5)* lights up in the display.
- ▷ The cooling temperature drops to the coldest value. SuperCool is activated.
- ▷ SuperCool is automatically deactivated after 12 hours. The appliance continues to operate in the energy-saving, normal mode.

To prematurely deactivate SuperCool

- ▶ Briefly press SuperCool button *Fig. 2 (4)*.
- ▷ The SuperCool symbol *Fig. 2 (5)* goes out in the display.
- ▷ SuperCool is deactivated.

Control

5.2.4 Fan*

With the fan you can rapidly cool large quantities of fresh food or achieve a relatively even distribution of temperature across all the storage levels.



The forced-air cooling is to be recommended:

- at high room temperature (above 33 °C)
- at high humidity

The forced-air cooling uses slightly more energy. To save energy, the fan switches off automatically when the door is open.

Switching on the fan*

- ▶ Briefly press the fan button *Fig. 2 (6)*.
- ▷ The fan symbol *Fig. 2 (7)* shines.
- ▷ The fan is active. In some appliances, the fan is only activated when the compressor is running.

To switch off the fan*

- ▶ Briefly press the fan button *Fig. 2 (6)*.
- ▷ The fan symbol *Fig. 2 (7)* goes out.
- ▷ The fan is switched off.

5.2.5 Shelves

Moving or removing shelves

The shelves have stops preventing them from being unintentionally pulled out.

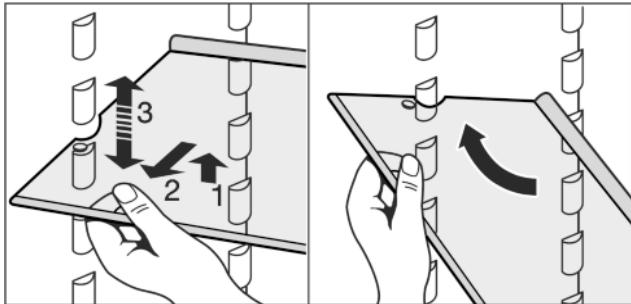
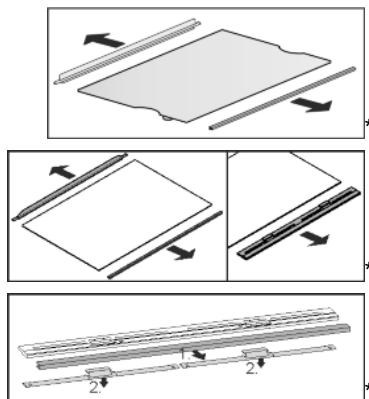

Fig. 3

- ▶ Lift the shelf slightly and pull forward a little.
- ▶ Adjust the height of the shelf. To do so, push the cut-outs along the supports.
- ▶ In order to remove the shelf fully, place it at a slant and pull out towards the front.
- ▶ Insert shelf with the raised edge pointing upwards at the back.
- ▷ The food does not freeze onto the rear wall.

Dismantling shelves



- ▶ The shelves can be dismantled for cleaning.

5.2.6 Using the sectioned shelf*

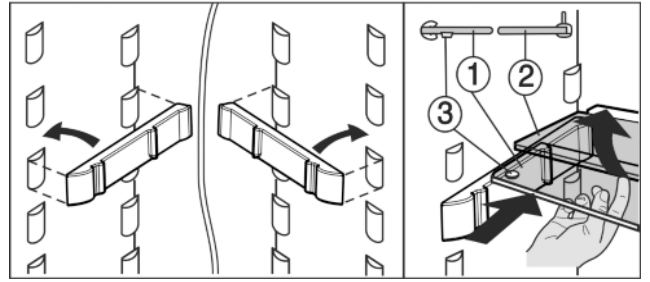
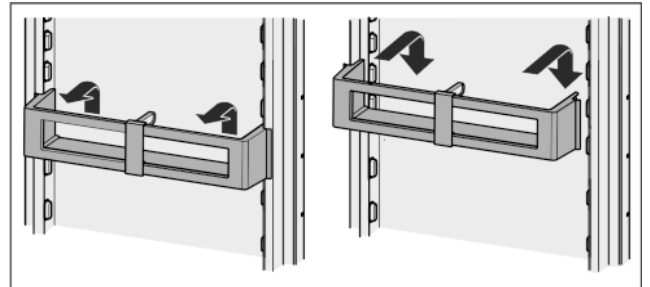

Fig. 4

- ▶ The glass shelf with stop face (2) has to be at the back.
- ▶ The glass plate (1) with pull-out stops must be at the front so that the stops (3) face downwards.

5.2.7 Door racks

Moving the storage rack*



*Fig. 5**

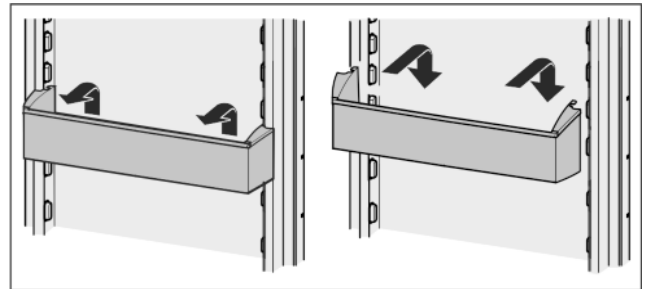

*Fig. 6**

Dismantling door racks*

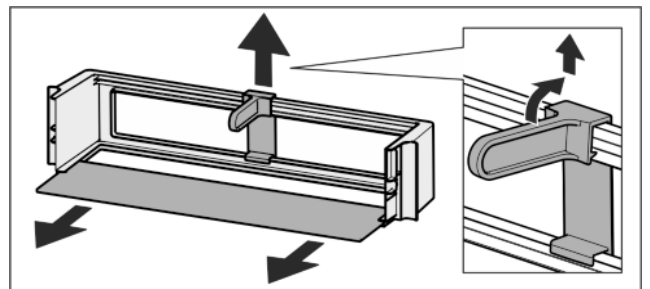
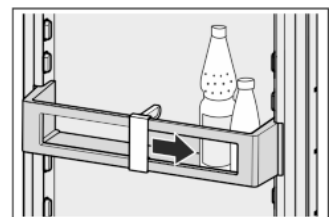

Fig. 7

- ▶ The door racks can be dismantled for cleaning.

5.2.8 Using the bottle holder*

- ▶ To avoid the bottles tipping over, push the bottle holder along.



5.2.9 Egg tray*

You can take out and rotate the egg tray. You can use the two parts of the egg tray to mark different use-by dates, for example.

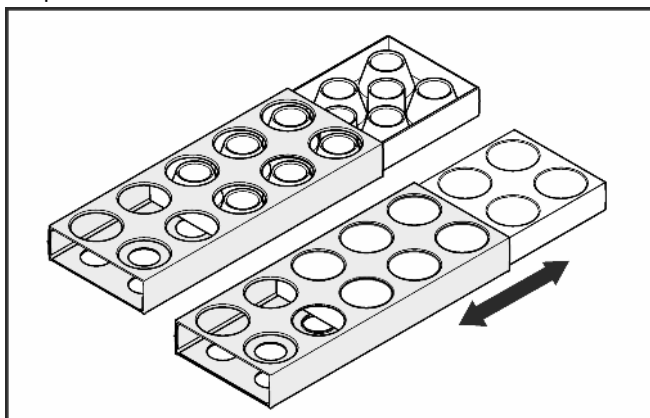

- ▶ Use the top part to store e.g. chicken eggs.
- ▶ Use the bottom part to store quails' eggs.

5.2.10 Vegetable drawers*

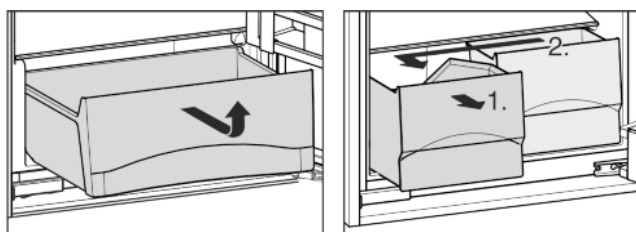

Fig. 8

5.2.11 BioCool box*

Controlling humidity

- ▶ Low humidity: Move the slide controller forward.

- ▶ High humidity: Move the slide controller back.

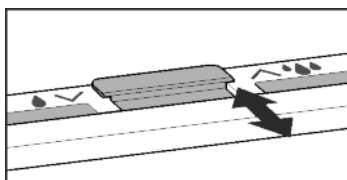

Removing the BioCool box

BioCool box without pull out:

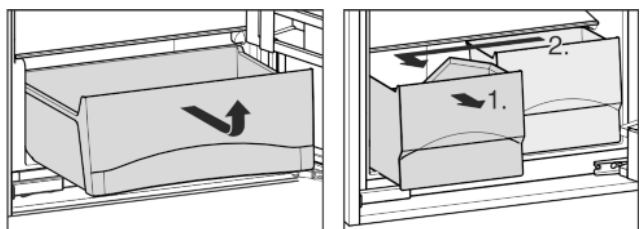

Fig. 9

BioCool box on roller plates:

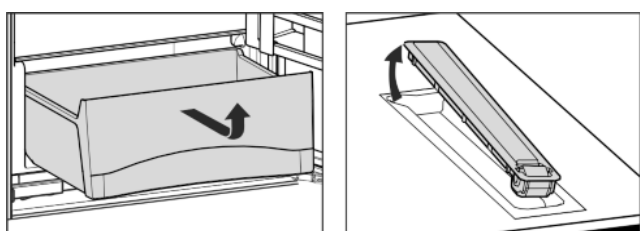

Fig. 10

- ▶ BioCool box and roller plates can be removed for cleaning. BioCool box on extendible rails:

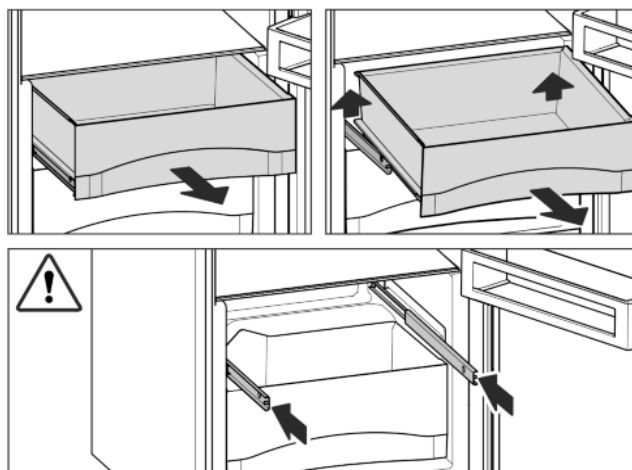

Fig. 11

- ▶ Pull out the drawer, lift it at the back and remove it from the front.
- ▶ Slide the rails in.
- ▶ BioCool box can be removed for cleaning.

5.3 Freezer compartment*

You can store frozen food for several months, make ice cubes and freeze fresh food in the freezer compartment at a temperature of $-18\text{ }^{\circ}\text{C}$ and lower.

The air temperature in the compartment, measured by thermometer or other instruments, may fluctuate.

5.3.1 Freezing food*

2 kg fresh food/24 h is the maximum weight which can be frozen.



CAUTION

Risk of injury due to broken glass!

Bottles and cans containing drinks may burst when being frozen. This applies particularly to sparkling drinks.

- ▶ Do not freeze bottles and cans containing drinks!

- ▶ 4 h before freezing food, set the temperature to $5\text{ }^{\circ}\text{C}$ or colder.

In order that the food is rapidly frozen through to the core, do not exceed the following quantities per pack:

- Fruit, vegetables up to 1 kg
- Meat up to 2.5 kg
- ▶ Pack the food in portions in freezer bags, reusable plastic, metal or aluminium containers.
- ▶ Spread the food over the shelf. Do not allow it to contact and thaw items that are already frozen.
- ▶ Set the temperature back again 24 h after placing the food inside.

5.3.2 Storage times*

Guide times for storing various types of food in the freezer compartment:

Ice cream	2 to 6 months
Sausage, ham	2 to 6 months
Bread, bakery products	2 to 6 months
Game, pork	6 to 10 months

Maintenance

Guide times for storing various types of food in the freezer compartment:	
Fish, fatty	2 to 6 months
Fish, lean	6 to 12 months
Cheese	2 to 6 months
Poultry, beef	6 to 12 months
Vegetables, fruit	6 to 12 months

Storage times given are guide times.

5.3.3 Thawing food*

- in the refrigerator compartment
- in a microwave oven
- in a conventional or fan oven
- at room temperature
- ▶ Remove only as much food as is required. Use thawed food as quickly as possible.
- ▶ Food once thawed should be re-frozen only in exceptional cases.

5.3.4 Ice cube tray*

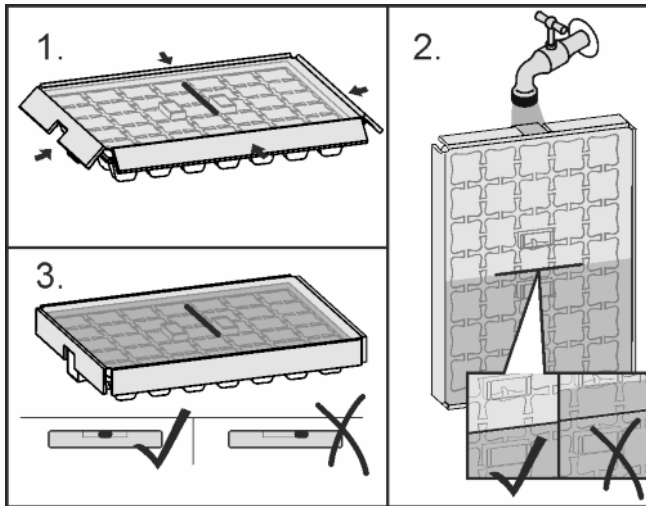

Fig. 12

When the water is frozen:

- ▶ Remove the lid.
- ▶ Gently turn the ends of the ice cube tray in opposite directions and release the cubes.

Dismantling the ice cube tray

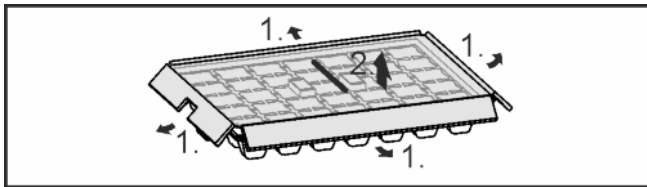

Fig. 13

- ▶ You can take the ice cube tray apart for cleaning.

6 Maintenance

6.1 Defrosting

6.1.1 Defrosting refrigerator compartment

The refrigerator compartment is defrosted automatically. The water evaporates. Drops of water on the rear wall are functionally conditioned and perfectly normal.

- ▶ Clean the drain hole at regular intervals to allow the defrost water to drain (see 6.2).

6.1.2 Defrosting freezer compartment*

A layer of frost and ice forms in the freezer compartment after the appliance has been in use for a lengthy period of time. This is quite normal. The layer of frost and ice forms more quickly if the door is opened frequently or if the food is warm when placed inside. However, a thick layer of ice will increase the appliance's energy consumption. You should therefore defrost the appliance regularly.



CAUTION

Risk of injury and damage as a result of hot steam!

- ▶ Do not use electric heaters or steam cleaners, naked flames or defrosting sprays for defrosting.
- ▶ Do not remove ice using sharp instruments.

- ▶ Switch off the appliance.
- ▷ The temperature display goes out.
- ▷ If the temperature display does not go out, the child-proofing function (see 5.1) is active.
- ▶ Pull out the plug.
- ▶ Wrap the frozen food in newspaper or blankets and store in a cool place.
- ▶ Leave the compartment and appliance door open during defrosting.
- ▶ Remove detached pieces of ice.
- ▶ Pay attention that the defrost water does not run into the kitchen unit.
- ▶ If necessary, pick up defrost water several times, using a sponge or cloth.
- ▶ Clean the compartment (see 6.2).

6.2 Cleaning the appliance



WARNING

Risk of injury and damage as a result of hot steam!

Hot steam can lead to burns and can damage the surfaces.

- ▶ Do not use any steam cleaners!

NOTICE

Incorrect cleaning damages the appliance!

- ▶ Do not use cleaning agents in concentrated form.
- ▶ Do not use any scouring or abrasive sponges or steel wool.
- ▶ Do not use any sharp or abrasive cleaning agents, nor any that contain sand, chloride or acid.
- ▶ Do not use chemical solvents.
- ▶ Do not damage or remove the type plate on the inside of the appliance. It is important for the customer service.
- ▶ Do not pull off, bend or damage cables or other components.
- ▶ Do not allow any cleaning water to enter the drain channel, ventilation grille or electrical parts.
- ▶ Please use soft cleaning cloths and a universal pH-neutral cleaning agent.
- ▶ Please use cleaning and care products suitable for contact with foodstuffs in the appliance interior.

- ▶ Empty appliance.
- ▶ Pull out the power plug.



- ▶ Clean **plastic outer and inner surfaces** with lukewarm water and a little washing-up liquid.

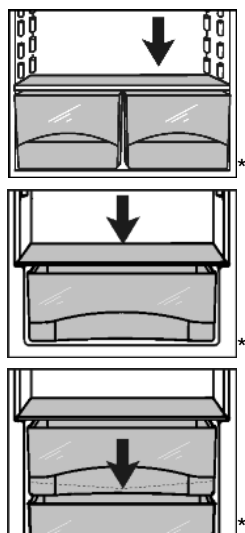

- ▶ Clean **drain hole**: Remove deposits with a narrow instrument, e.g. a cotton bud.

- ▶ Most of the **parts** can be dismantled for cleaning: see the relevant chapter.
- ▶ **Clean drawers** by hand with lukewarm water and a little washing up liquid.
- ▶ All the **other fittings** can be put in the dishwasher.
- ▶ **Vegetable bin roller bases** can also be cleaned in the dishwasher.*
- ▶ Only use a damp cloth to clean the **telescopic rails**. The grease in the runners is for lubrication purposes and must not be removed.*

After cleaning:

- ▶ Wipe dry the appliance and items of equipment.
- ▶ Connect the appliance and switch it on again.
- ▶ Put the food back inside.

6.3 Customer service

First check whether you can correct the fault yourself by reference to the list (see Malfunction). If this is not the case, please contact the customer service whose address is given in the enclosed customer service list.



WARNING

Risk of injury if repair work is not carried out professionally!

- ▶ Have any repairs and action - not expressly specified - on the appliance and mains cable carried out by service personnel only. (see Maintenance)

- ▶ Read the appliance designation *Fig. 14 (1)*, service No. *Fig. 14 (2)* and serial No. *Fig. 14 (3)* off the type plate located inside the appliance on the left-hand side.

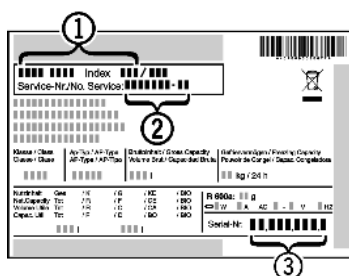

Fig. 14

- ▶ Notify the customer service, specifying the fault, appliance designation *Fig. 14 (1)*, service No. *Fig. 14 (2)* and serial No. *Fig. 14 (3)*.
- ▷ This will help us to provide you with a faster and more accurate service.
- ▶ Keep the appliance closed until the customer service arrives.
- ▷ The food will stay cool longer.
- ▶ Pull out the mains plug (not by pulling the connecting cable) or switch off the fuse.

7 Malfunctions

Your appliance is designed and manufactured for a long life span and reliable operation. If a malfunction nonetheless occurs during operation, check whether it is due to a handling error. In this case you will have to be charged for the costs incurred, even during the warranty period. You may be able to rectify the following faults yourself:

Appliance does not work.

- The appliance is not switched on.
- ▶ Switch on the appliance.
- The power plug is not properly inserted in the wall socket.
- ▶ Check power plug.
- The fuse of the wall socket is not in order.
- ▶ Check fuse.

The compressor runs for a long time.

- The compressor switches to a low speed when little cold is needed. Although the running time is increased as a result, energy is saved.
- ▶ This is normal in energy-saving models.
- SuperCool is activated.
- ▶ The compressor runs for longer in order to rapidly cool the food. This is normal.

A LED on the bottom rear of the appliance (at the compressor) flashes repeatedly every 5 seconds*.

- There is a fault.
- ▶ Please contact the after-sales service (see Maintenance).

Excessive noise.

- Due to the various speed steps, speed-regulated* compressors can generate different running noises.
- ▶ The sound is normal.

A bubbling and gurgling noise.

- This noise comes from the refrigerant flowing in the refrigeration circuit.
- ▶ The sound is normal.

A quiet clicking noise.

- The noise is produced whenever the refrigeration unit (motor) automatically switches on or off.
- ▶ The sound is normal.

A hum. It is briefly a little louder when the refrigeration unit (the motor) switches on.

- The refrigeration increases automatically when the SuperCool function is activated, fresh food has just been placed in the appliance or the door has been left open for a while.
- ▶ The sound is normal.
- The ambient temperature is too high.
- ▶ Solution: (see 1.2)

A low hum.*

- The sound is produced by air flow noise of the fan.
- ▶ The sound is normal.

Vibration noises*

- The appliance is not standing firmly on the floor. As a result objects and adjacent units start to vibrate when the refrigerator is running.
- ▶ Check the installation and realign the appliance.*
- ▶ Keep bottles and jars apart.*

The temperature display indicates: F0 to F9

- There is a fault.
- ▶ Please contact the after-sales service (see Maintenance).

DEMO shines in the temperature display.

- The demo mode is activated.
- ▶ Please contact the after-sales service (see Maintenance).

Decommissioning

The outer surfaces of the appliance are warm*.

→ The heat of the refrigeration circuit is used to prevent condensate from forming.

▶ This is normal.

The temperature is not cold enough.

→ The door of the appliance is not properly closed.

▶ Close the door of the appliance.

→ Insufficient ventilation.

▶ Keep ventilation grille clear, and clean it.

→ The ambient temperature is too high.

▶ Solution: (see 1.2) .

→ The appliance was opened too frequently or for too long.

▶ Wait to see whether the appliance reaches the required temperature by itself. If not, please contact the after sales service (see Maintenance).

→ The temperature is incorrectly set.

▶ Set the temperature to a colder setting and check after 24 hours.

→ The appliance is too close to a source of heat (stove, heater etc).

▶ Change the position of the appliance or the source of heat.

→ The appliance was not inserted properly into the recess.

▶ Check whether the appliance was inserted correctly and the door closes properly.

The internal light does not come on.

→ The appliance is not switched on.

▶ Switch the appliance on.

→ The door was open for longer than 15 minutes.

▶ The internal light switches itself off automatically after about 15 minutes if the door is open.

→ The LED illumination is faulty or the cover is damaged:

▶ Remove mains connector.

▶ Clean the appliance (see 6.2) .



▶ Leave the door open to prevent odour.

9 Disposing of the appliance

The appliance contains some reusable materials and should be disposed of properly - not simply with unsorted household refuse. Appliances which are no longer needed must be disposed of in a professional and appropriate way, in accordance with the current local regulations and laws.



When disposing of the appliance, ensure that the refrigeration circuit is not damaged to prevent uncontrolled escape of the refrigerant it contains (data on type plate) and oil.

▶ Disable the appliance.

▶ Pull out the plug.

▶ Cut through the connecting cable.



WARNING

Risk of injury due to electric shock!

Live parts are located under the cover.

▶ Have the LED interior light changed or repaired only by the customer service or by specialized personnel trained for the purpose.



WARNING

Danger of injury by LED lamp!

The light intensity of the LED illumination corresponds to laser class 1/1M.

If the cover is defective:

▶ Do not look into the illumination with optical lenses from the immediate proximity. This can cause injury to the eyes.

8 Decommissioning

8.1 Switching off the appliance

▶ Press On/Off button *Fig. 2 (1)* for approx. 2 seconds.

▷ A long beep is emitted. The temperature display is dark. The appliance is switched off.

▷ If the appliance cannot be switched off, the child lock function is active (see 5.1) .



8.2 Taking the appliance out of service

▶ Empty the appliance.

▶ Switch off the appliance (see Decommissioning).



Liebherr-Hausgeräte Ochsenhausen GmbH

Memminger Straße 77-79

88416 Ochsenhausen

Deutschland

home.liebherr.com