

Miele

Operating and installation instructions

Freezer



To avoid the risk of accidents or damage to the appliance it is **essential** to read these instructions before it is installed and used for the first time.

Contents

Warning and Safety instructions	4
Caring for the environment	11
How to save energy	12
Guide to the appliance	14
Switching on and off	16
Before using for the first time	16
Cleaning and care	16
Switching off for longer periods of time	17
The correct temperature	18
Setting the temperature.....	18
Temperature display	18
Using Super freeze	19
Super freeze function	19
Temperature alarm	20
Switching the temperature alarm off early	20
Selecting further settings	21
Settings mode	21
Freezing and storing food	23
Maximum freezing capacity	23
Freezing fresh food.....	23
Storing frozen food.....	23
Home freezing	24
Adjusting the interior fittings.....	27
Using accessories	27
Defrosting	28
Cleaning and care	31
Cleaning agents.....	31
Preparing the appliance for cleaning.....	32
Cleaning the interior and accessories	32
Cleaning the door seal	32
Cleaning the ventilation gaps	33
Problem solving guide	34
Noises	39

After Sales / Guarantee	40
Electrical connection	41
Installation	42
Location.....	42
Ventilation.....	43
Before installing the appliance	44
Does your old appliance have a different hinging mechanism?	45
Stainless steel front	45
Building-in dimensions	46
Changing the door hinging	47
Changing the door hinging.....	47
Installing the appliance	50
Fitting the furniture door.....	57

Warning and Safety instructions

This appliance complies with all statutory safety requirements. Please note that inappropriate use can lead to personal injury and damage to property.

To avoid the risk of accidents and damage to the appliance, please read these instructions carefully before using it for the first time. They contain important notes on installation, safety, use and maintenance.

Miele cannot be held liable for non-compliance with these instructions.

Keep these instructions in a safe place and ensure that new users are familiar with the contents. Pass them on to any future owner.

Correct application

- ▶ This appliance is intended for use in domestic households and similar working and residential environments. It is not intended for outdoor use.
- ▶ It must only be used as a domestic appliance to store deep frozen food, freeze fresh food and to make ice. Any other usage is not supported by the manufacturer and could be dangerous.
- ▶ This appliance is not suitable for storing and keeping cool medicines, blood plasma, laboratory preparations or other such materials or products. Incorrect use of the appliance for such purposes can cause deterioration of the items stored. The appliance is not suitable for use in areas where there is a risk of explosion. Miele cannot be held liable for damage resulting from improper or incorrect use of the appliance.

Warning and Safety instructions

▶ The appliance can only be used by people with reduced physical, sensory or mental capabilities, or lack of experience and knowledge, if they are supervised whilst using it, or have been shown how to use it in a safe way and recognise and understand the consequences of incorrect operation.

Safety with children

- ▶ Children under 8 years of age must be kept away from the appliance unless they are constantly supervised.
- ▶ Children 8 years and older may only use the appliance unsupervised if they have been shown how to use it in a safe way and recognise and understand the consequences of incorrect operation.
- ▶ Children must not be allowed to clean or maintain the appliance unsupervised.
- ▶ Please supervise children in the vicinity of the appliance and do not let them play with it.
- ▶ Danger of suffocation. Packaging, e.g. plastic wrappings, must be kept out of the reach of babies and children. Whilst playing, children could become entangled in packaging or pull it over their head and suffocate.

Technical safety

- ▶ The coolant system is tested for leaks. This appliance complies with statutory safety requirements and the appropriate EU guidelines.

Warning and Safety instructions

▶ This appliance contains the coolant Isobutane (R600a), a natural gas which is environmentally friendly. Although it is flammable, it does not damage the ozone layer and does not increase the greenhouse effect.

The use of this coolant has, however, led to a slight increase in the noise level of the appliance. In addition to the noise of the compressor, you might be able to hear the coolant flowing around the system. This is unavoidable, and does not have any adverse effect on the performance of the appliance.

Care must be taken during the transportation and setting up of the appliance that no parts of the cooling system are damaged. Leaking coolant can damage the eyes.

In the event of any damage:

- avoid naked flames or anything which creates a spark,
- disconnect the appliance from the mains electricity supply,
- ventilate the room where the appliance is located for several minutes, and
- contact the Miele Service Department.

▶ The more coolant there is in an appliance, the larger the room it should be installed in. In the event of a leakage, if the appliance is in a small room, there is the danger of combustible gases building up. For every 8 g of coolant at least 1 m³ of room space is required. The amount of coolant in the appliance is stated on the data plate inside the appliance.

▶ To avoid the risk of damage to the appliance, make sure that the connection data (fuse rating, frequency and voltage) on the data plate corresponds to the household supply. Check that this is the case before connecting the appliance. Consult a qualified electrician if in any doubt.

▶ The electrical safety of this appliance can only be guaranteed when correctly earthed. It is essential that this standard safety requirement is met. If in any doubt please have the electrical installation tested by a qualified electrician.

Warning and Safety instructions

- ▶ Reliable and safe operation of this appliance can only be assured if it has been connected to the mains electricity supply.
- ▶ If the electrical connection cable is faulty it must only be replaced by a Miele authorised service technician to protect the user from danger.
- ▶ Do not connect the appliance to the mains electrical supply by a multi-socket adapter or extension lead. These are a fire hazard and do not guarantee the required safety of the appliance.
- ▶ Do not use in a damp or wet environment (e.g. garage or utility room). Moisture could reach live components or the electrical connection and cause a short circuit.
- ▶ This appliance must not be used in a non-stationary location (e.g. on a ship).
- ▶ Do not use a damaged appliance. It could be dangerous. Check the appliance for visible signs of damage.
- ▶ For safety reasons, this appliance may only be used after it has been built in.
- ▶ The appliance must be isolated from the electricity supply during installation, maintenance and repair work.
- ▶ Unauthorised installation, maintenance and repairs can cause considerable danger for the user. Installation, maintenance and repairs must only be carried out by a Miele authorised technician.
- ▶ While the appliance is under guarantee, repairs should only be undertaken by a Miele authorised service technician. Otherwise the guarantee is invalidated.
- ▶ Miele can only guarantee the safety of the appliance when genuine original Miele replacement parts are used. Faulty components must only be replaced by Miele spare parts.

Warning and Safety instructions

Correct use

- ▶ The appliance is designed for use within a certain climate range (ambient temperatures), and should not be used outside this range. The climate range for your appliance is stated on the data plate inside the appliance. Installing it in a room with too low an ambient temperature, e.g. a garage, will lead to the appliance switching off for longer periods so that it cannot maintain the required temperature.
- ▶ Do not cover or block the air vents as this could impair the efficiency of the appliance, increase the electricity consumption and could cause damage to the components.
- ▶ If storing food which contains a lot of fat or oil in the appliance or the door, make sure that it does not come into contact with plastic components as this could cause stress cracks or break the plastic.
- ▶ Do not store explosive materials in the appliance or any products containing propellants (e.g. spray cans). Electrical components could cause flammable vapours to ignite. Danger of fire and explosion.
- ▶ Do not operate any electrical equipment (e.g. an electric ice cream maker) inside the appliance. Danger of sparking and explosion.
- ▶ Do not store cans or bottles containing carbonated drinks or liquids which could freeze in the freezer. The cans or bottles could explode. Danger of injury and damage to the appliance.
- ▶ When cooling drinks quickly in the freezer, make sure bottles are not left in for more than one hour; otherwise they could burst, causing injury or damage.
- ▶ Never handle frozen food or the metal parts of the appliance with wet hands. Your hands may freeze to the frozen food or to the metal. Danger of frost burn.

Warning and Safety instructions

- ▶ Do not take ice cubes out with your bare hands and never place ice cubes or ice lollies in your mouth straight from the freezer. The very low temperature of the frozen ice or lollies can cause frost burn to the lips and tongue.
- ▶ Do not refreeze partially or fully defrosted food. Consume defrosted food as soon as possible, as it will lose its nutritional value and spoil if left for too long. Defrosted food may only be re-frozen after it has been cooked.
- ▶ Observe the manufacturer's "use-by" dates and storage instructions given on food to avoid the risk of food poisoning. Storage times will depend on several factors, including the freshness and quality of the food, as well as the temperature at which it is stored.
- ▶ Only use genuine original Miele accessories and spare parts with this appliance. Using accessories or spare parts from other manufacturers will invalidate the guarantee, and Miele cannot accept liability.

Cleaning and care

- ▶ Do not use any oils or grease on the door seals, as these will cause the seals to deteriorate and become porous with time.
- ▶ Do not use a steam cleaning appliance to clean or defrost this appliance. Steam could reach electrical components and cause a short circuit.
- ▶ Sharp edged or pointed objects will damage the evaporator, causing irreversible damage to the appliance. Do not use sharp edged or pointed objects to
 - remove frost and ice,
 - separate frozen foods or remove ice trays.
- ▶ Do not place electric heaters or candles in the appliance to defrost it. These can damage the plastic parts.

Warning and Safety instructions

▶ Do not use defrosting sprays or de-icers, as they could contain substances which could damage the plastic parts or which might cause the build-up of gases and pose a danger to health.

Transporting the appliance

▶ Always transport the appliance in an upright position and in its original transport packaging to avoid damage in transit.

▶ Danger of injury and damage. The appliance is very heavy and must be transported by two people.

Disposal of your old appliance

▶ Before disposing of an old appliance, first make the door latch or lock unusable.

This way you will prevent children from accidentally locking themselves in and endangering their lives.

▶ Splashes of coolant can damage the eyes. Be careful not to damage any part of the pipework whilst awaiting disposal, e.g. by

- puncturing the coolant channels in the condenser,
- bending any pipework, or
- scratching the surface coating.

Symbol on the compressor (depending on model)

This information is only relevant for recycling. In normal operation there is no risk.



▶ The oil in the compressor can be fatal if swallowed or if it penetrates the airways.

Disposal of the packing material

The packaging is designed to protect the appliance from damage during transportation. The packaging materials used are selected from materials which are environmentally friendly for disposal and should be recycled.

Recycling the packaging reduces the use of raw materials in the manufacturing process and also reduces the amount of waste in landfill sites.

Disposal of your old appliance

Electrical and electronic equipment often contain valuable materials. They also contain materials which, if handled or disposed of incorrectly, could be potentially hazardous to human health and to the environment. They are, however, essential for the correct functioning of your appliance. Please do not therefore dispose of it with your household waste.

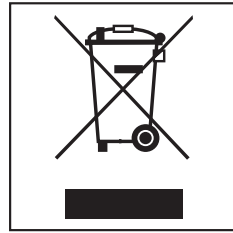

Please dispose of it at your local community waste collection / recycling centre.

Take care not to damage the pipework at the back of it before or during transportation to an authorised collection depot.

In this way, coolant in the pipework and oil in the compressor will be contained, and will not leak into the environment.

Please ensure that your old appliance presents no danger to children while being stored awaiting disposal. See "Warning and Safety instructions" for more information.

How to save energy

	Normal energy consumption	Increased energy consumption
Installation site / Maintenance	In a ventilated room.	In an enclosed, unventilated room.
	Protected from direct sunlight.	In direct sunlight.
	Not near to a heat source (radiator, oven).	Near to a heat source (radiator, oven).
	Where the ideal ambient room temperature is approx. 20 °C.	Where there is a high ambient room temperature.
	Ventilation gaps uncovered and dusted regularly.	Ventilation gaps covered or dusty.
Temperature setting	Freezer section -18 °C	The lower the temperature in the appliance, the higher the energy consumption.

How to save energy

	Normal energy consumption	Increased energy consumption
Use	Drawers and shelves arranged as they were when the appliance was delivered.	
	Only open the door when necessary and for as short a time as possible. Store food in an organised way.	Frequent opening of the door for long periods will cause a loss of coldness. The appliance works harder to cool down and the compressor runs for longer periods.
	Take an insulated cool bag when shopping and load food in the appliance as soon as possible. Allow hot food and drinks to cool down before placing them in the appliance.	Hot food or food at room temperature raises the temperature inside the appliance. The appliance works harder to cool down and the compressor runs for longer periods.
	Store food well packaged.	The evaporation or condensation of liquids will cause a loss of coldness.
	Do not over-fill the appliance to allow air to circulate.	Poor air circulation will cause a loss of coldness.
Defrosting	Defrost the freezer when a layer of ice 0.5 cm (max.) thick has built up.	A build-up of ice slows down the cooling process.

Guide to the appliance

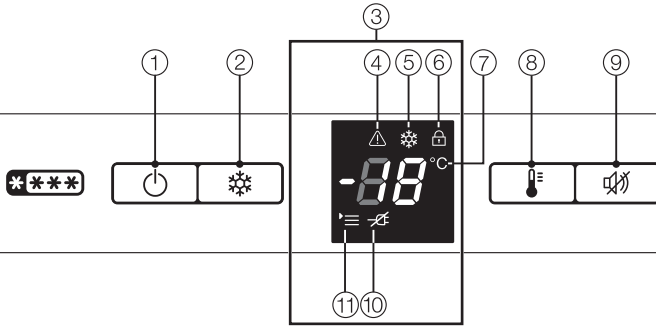

- ① On/Off button
- ② Super freeze button
- ③ Display
The brightness of the display changes automatically to the set brightness level if the appliance has not been used for a while. As soon as a sensor is touched the display lights up to the maximum brightness level.
- ④ Alarm symbol
- ⑤ Super freeze symbol
- ⑥ Lock symbol
- ⑦ Temperature display
- ⑧ Temperature selector button
- ⑨ Alarm off button
- ⑩ Power failure symbol
- ⑪ Menu symbol
(Settings mode:
for altering the display brightness level,
for switching the safety lock on/off)

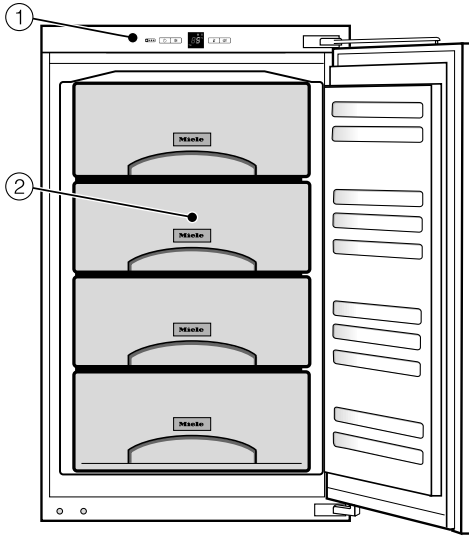

- ① Control panel
- ② Freezer drawers

Switching on and off

Before using for the first time

Packaging material

- Remove all packaging material from the inside of the appliance.

Cleaning and care

Please refer to the relevant instructions in "Cleaning and care".

- Clean the inside of the appliance and the accessories.

Switching on

To enable the temperature to get sufficiently cold inside the appliance, allow the appliance to run for approx. 2 hours before placing food in it. Do not place food in the freezer until the temperature is at least -18°C .



- Press the On/Off button.

The appliance will start to cool and the temperature required will appear in the temperature display. The temperature display and the alarm symbol  will flash simultaneously until the required temperature is reached.

Switching off



- Press the On/Off button until the display goes out. If this does not happen, the safety lock is still activated (see "Selecting further settings - To deactivate the safety lock").

The interior lighting will go out and the cooling process will be switched off.

Switching off for longer periods of time

 If, during a long absence, the appliance is switched off but not cleaned and the door(s) left shut, there is a danger of mould building up inside the appliance. It is essential to clean the appliance.

If the appliance is not going to be used for a longer period of time, e.g. whilst on holiday:

- switch the appliance off,
- disconnect it from the mains,
- defrost the freezer,
- clean the appliance and
- leave the door(s) ajar to air the appliance and avoid odours building up inside the appliance.

The correct temperature

It is very important to set the correct temperature for storing food in the appliance. Micro-organisms will cause food which is not stored at the correct temperature to deteriorate rapidly. Temperature influences the growth rate of these micro-organisms. Reducing the temperature reduces their growth rate.

To freeze fresh food and to store frozen food for a long time, a temperature of **-18 °C** is required. At this temperature the growth of micro-organisms is generally halted. As soon as the temperature rises above -10 °C, the micro-organisms become active in the food again so that it cannot be kept as long. For this reason, partially defrosted or fully defrosted food must not be re-frozen. Food may be re-frozen once it has been cooked, as the high temperatures achieved when cooking destroy most micro-organisms.

The temperature in the appliance will rise:

- the more often the door is opened and the longer it is kept open,
- the more food that is stored in it,
- the warmer the food is which is being put into it,
- the higher the ambient temperature surrounding the appliance. The appliance is designed for use within specific ambient temperatures (climate range). Do not use in ambient temperatures for which it is not designed.

Setting the temperature



- Press the button for setting the temperature repeatedly until the temperature you want lights up in the temperature display.

The first time you press the button the last temperature set will flash in the display.

The temperature value will change up until the setting for -28 °C is reached. It will then drop back to the -15 °C setting.

The newly selected temperature will be adopted automatically after a short while and will appear in the temperature display.

The temperature in the appliance will now slowly start to adjust to this value.

Temperature display

The temperature display on the control panel always shows the **required** temperature for the freezer.

Super freeze function

Switch on Super freeze before putting fresh food into the freezer.

This helps food to freeze quickly and retain its nutrients, vitamins, flavours and appearance.

Super freeze is not necessary:

- when placing food in the freezer that is already frozen.
- when freezing up to 1 kg fresh food daily.

Switching on Super freeze

When freezing small quantities of food in the freezer, the Super freeze function should be switched on **6 hours beforehand**. When freezing **the maximum load of food**, the Super freeze function should be switched on **24 hours beforehand**.



- Press the Super freeze button briefly.

The Super freeze symbol ❄ will light up. The appliance will work at full power to lower the temperature in the appliance.

Switching off Super freeze

The Super freeze function will switch off automatically after approx. 65 hours. The Super freeze symbol ❄ will go out and the appliance will run at normal power again.

To save energy, you can switch the Super freeze function off yourself before this time.



- Press the Super freeze button until the symbol ❄ goes out.

The appliance will continue running at normal power.

Temperature alarm

The appliance has been fitted with a warning system which ensures that the temperature in the freezer cannot rise unnoticed.

If the temperature in the freezer becomes too warm, the temperature and the alarm symbol  will flash in the display. An alarm will also sound.

The temperature the appliance is set at determines the temperature the appliance recognises as being too warm.

Audible and visual signals will be activated, for example,

- when the appliance is switched on if the temperature in the appliance differs greatly from the set temperature,
- if a lot of room air enters the freezer when food is being loaded, re-arranged or taken out,
- when freezing large amounts of food at once,
- when freezing fresh food which is still warm,
- in the event of a power cut,
- if the appliance has a fault.

The alarm will stop and the alarm symbol  will go out as soon as the temperature has dropped down to the correct level again.

Switching the temperature alarm off early

If the noise disturbs you, you can switch the alarm off if you wish.



- Press the Alarm off button.

The alarm will stop.

The alarm symbol  will remain illuminated until the set temperature has been reached.

The alarm cannot be switched off early in Settings mode.

 If the temperature in the freezer remains above $-18\text{ }^{\circ}\text{C}$ for a long time, check that the frozen food has not started to defrost.

If it has, check that the food is safe to use and if it is, then use it as soon as possible or cook it before freezing it again.

Settings mode

Settings mode is used for activating and deactivating the safety lock.



Activating or deactivating the safety lock	c
--	---

Settings mode is represented in the display by the menu symbol '≡.

See below for instructions on how to **activate and deactivate the lock**.

Activating or deactivating the safety lock

The lock can be activated to prevent the appliance being switched off by mistake.

– To activate the safety lock



- Press the Super freeze button for approx. 5 seconds.

The menu symbol '≡ will light up and c will start flashing in the display. Settings mode is now activated.



- Press the Super freeze button briefly to access the lock function.

c7 will appear in the display.

- Press the Super freeze button briefly to activate the lock.

The lock symbol  will light up.



- Press the On/Off button to exit Settings mode.



The temperature will appear in the display.

Selecting further settings

- To deactivate the safety lock



- Press the Super freeze button for approx. 5 seconds.

The lock symbol  and the Menu symbol  will light up and  will start flashing in the display.

Settings mode is now activated.



- Press the Super freeze button briefly to access the lock function.

 will appear in the display.



- Press the Super freeze button briefly to deactivate the lock.

The lock symbol  will go out.



- Press the On/Off button to exit Settings mode.

The temperature will appear in the display.

Maximum freezing capacity

To ensure that fresh food placed in the freezer freezes through to the core as quickly as possible, the maximum freezing capacity must not be exceeded. The maximum freezing capacity for freezing within a 24-hour period is given on the data plate: "Freezing capacitykg/24 hrs".

The maximum freezing capacity given on the data plate has been calculated according to DIN EN ISO 15502 Standard.

Freezing fresh food

Fresh food should be frozen as quickly as possible. This way the nutritional value of the food, its vitamin content, appearance and taste are not impaired.

Food which takes a long time to freeze will lose more water from its cells, which then shrink. During the defrosting process, only some of this water is reabsorbed by the cells; the rest collects around the food.

If food is frozen quickly, the cells have less time to lose moisture, so they shrink less. As there is not so much moisture loss, it is easier for the food to reabsorb it during the defrosting process, and very little water collects around the defrosted food.

Storing frozen food

When buying frozen food to store in your freezer, check

- that the packaging is not damaged,
 - the use-by date,
 - the temperature at which the frozen food is being stored in the shop. The length of time it can be kept is reduced if it has been stored at a temperature warmer than -18°C .
- Buy frozen food once you have finished the rest of your shopping, and wrap it in newspaper or use a cool bag or cool box to transport it.
 - Store it in the freezer as soon as possible.

Never re-freeze partially or fully defrosted food. Consume defrosted food as soon as possible as it will lose its nutritional value and spoil if left for too long. Defrosted food may only be re-frozen after it has been cooked.

Freezing and storing food

Home freezing

Only freeze fresh food which is in a good condition.

Hints on home freezing

- The following types of food **are suitable** for freezing:
Fresh meat, poultry, game, fish, vegetables, herbs, fresh fruit, dairy products, cakes, leftovers, egg yolks, egg whites and a range of pre-cooked meals.
- The following types of food **are not suitable** for freezing:
Grapes, lettuce, radishes, sour cream, mayonnaise, eggs in their shells, onions, whole raw apples and pears.
- To retain colour, taste, aroma and vitamin C, vegetables should be blanched after they have been trimmed and washed. To blanch: bring a large saucepan of water to the boil, immerse the vegetables in the fast boiling water for 2 - 3 minutes, depending on variety. Remove, and plunge into ice-cold water to cool quickly. Drain and pack ready for freezing.
- Lean meat freezes better than fatty meat, and can be stored for considerably longer.
- To prevent chops, steaks, cutlets or rolled meat from freezing together in solid blocks when packed, separate with a sheet of plastic freezer film.
- Do not season fresh foods or blanched vegetables before freezing. Only season cooked food lightly be-

fore freezing, but care should be taken as the taste of some spices alters when frozen.

- Placing hot foods or drinks in the freezer causes food that is already frozen to partially thaw and increases energy consumption. Allow hot foods and drinks to cool down before placing them in the freezer.

Packaging

- Freeze food in portions.

Suitable packing material

- plastic freezer film
- freezer bags
- aluminium foil
- freezer containers

Unsuitable packing material

- wrapping paper
- grease-proof paper
- cellophane
- bin bags
- plastic carrier bags
- Expel as much air as possible from the packaging.
- Close the packaging tightly with
 - rubber bands
 - plastic clips
 - string or bag ties
 - freezer tape.

Tip: Freezer bags may also be sealed using home heat sealing kits.

Freezing and storing food

- Make a note of the contents and the date of freezing on the packaging.

Before placing food in the freezer

- When freezing more than 1 kg of fresh food, switch on the Super freeze function for some time before placing the food in the freezer (see "Using Super cool and Super freeze - Super freeze function").

This helps food which is already stored in the freezer to stay frozen.

Placing food in the freezer

 The following maximum loading weights must not be exceeded:
– freezer drawer = 25 kg
– glass cold plate = 35 kg

Unfrozen food should not touch frozen food as this will cause frozen food to begin to thaw.

- Make sure that the packaging and containers are dry to prevent them sticking together when frozen.

- Freezing small amounts of food

Place the food in the lower freezer drawers.

- Place the food flat in the bottom of the freezer drawer so that it freezes through to the core as quickly as possible.

- Freezing the maximum amount (see data plate)

- Remove the lowest freezer drawer.
- Place the food flat on the bottom of the appliance or in contact with the interior side walls, so that it freezes through to the core as quickly as possible.

Once frozen:

- Place the frozen food in the freezer drawer and push it back in.

Freezing and storing food

Storage time for frozen food

The storage life of food is very variable, even at a constant temperature of -18 °C. Decomposition processes also take place in frozen food, albeit at a very reduced speed. For example fat can become rancid from contact with oxygen in the air. This is why lean meat can be stored approx. twice as long as fatty meat.

The storage times quoted are guide values for the storage life of different food groups in the freezer section.

Food group	Storage time (Months)
Ice cream	2 to 6
Bread, baked goods	2 to 6
Cheese	2 to 4
Fish, oily	1 to 2
Fish, lean	1 to 5
Sausage, ham	1 to 3
Game, pork	1 to 12
Poultry, beef	2 to 10
Vegetables, fruit	6 to 18
Herbs	6 to 10

Where the storage time given on the packaging differs, follow the advice on the packaging.

Defrosting

Frozen food can be defrosted in different ways:

- in a microwave oven,
- in an oven using "Fan heat" or the "Defrost" setting,
- at room temperature,
- in the refrigerator section (the cold given off by the frozen food helps to keep the other food cold),
- in a steam oven.

Flat pieces of partially thawed fish can be placed directly into a hot frying pan.

Meat and poultry It is particularly important to observe food hygiene rules when defrosting poultry. Do not use the liquid from defrosted poultry. Pour it away and wash the container it was in, the sink and your hands. Danger of salmonella poisoning. Ensure that meat and fish (e.g. mince, chicken, fish fillets) do not come into contact with other foods while defrosting. Catch the liquid and dispose of it carefully.

Fruit should be defrosted at room temperature in its packaging, or in a covered bowl.

Most vegetables can be cooked while still frozen. Just put straight into boiling water or hot fat. The cooking time is slightly less than that of fresh vegetables due to changes in the cell structure.

Never re-freeze partially or fully defrosted food. Consume defrosted food as soon as possible as it will lose its nutritional value and spoil if left for too long. Defrosted food may only be re-frozen after it has been cooked.

Cooling drinks quickly

When cooling drinks quickly in the freezer, make sure bottles are **not left in for more than one hour**; otherwise they could burst, causing injury and damage.

Adjusting the interior fittings

Removing the drawers and glass plates from the freezer

The drawers can be removed for filling, emptying or cleaning purposes.

You can also use the space in the freezer more flexibly. If you wish to freeze large items such as a turkey or game, the glass cold plates between the drawers can be removed.

- Pull out the drawers as far as they will go, and then lift them up and out.
- Lift the glass plate slightly, pull it forwards and out.

Using accessories

Ice cubes

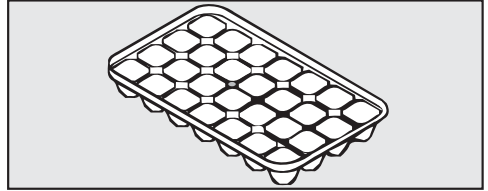

- Fill the ice cube tray three quarters full of water and place it on the bottom of one of the freezer drawers.
- Once frozen, use a blunt instrument, for example a spoon handle, to remove the ice tray from the freezer if it is stuck.

Tip: Ice cubes can be removed easily from the tray by twisting the tray gently or by holding it under cold running water for a short time.

Defrosting

The freezer does not defrost automatically.

In normal use, ice and frost will form in the freezer, e.g. on the internal walls. How much ice and frost accumulates in the appliance will depend on the following:

- whether the appliance door has been opened frequently or left open for a while.
- whether a large quantity of food has been placed in the freezer at once.
- whether the humidity in the room has increased.

Too thick a layer of ice will make it hard to remove freezer drawers, and in certain circumstances can prevent the door from closing properly. Too thick a layer of ice also reduces efficiency and increases energy consumption.

- The freezer should be defrosted from time to time. It must be defrosted if a layer of ice approx. 0.5 cm thick has accumulated.

The best time to defrost the freezer is when:

- there is very little or no frozen food left in the freezer.
- the humidity level in the room is low and the ambient temperature in the room is also low.

 When defrosting the freezer make sure that you do not damage the evaporator as this would cause irreversible damage to the appliance. Do not scrape off ice and frost and do not use any sharp edged or pointed instruments to aid the defrosting process.

Before defrosting

- Switch on the Super freeze function approx. 1 day before defrosting to ensure frozen food retains its cold reserve for longer when taken out of the freezer.

- Remove the frozen food from the freezer and wrap it in several layers of newspaper or cloths.

Tip: You could also place the frozen food in a cool box or bag.

- Store in a cool place until the freezer is ready for use again.
- Remove all the freezer drawers and glass cold plates from the freezer.

To defrost

 The longer the food is left out at room temperature, the faster it defrosts.

Carry out the defrosting procedure as quickly as possible.

 Steam from a steam cleaning appliance could reach the electrical components and cause a short circuit.

Do not use a steam cleaning appliance to defrost the appliance.

 Do not place electric heaters or candles in the appliance to defrost it. These can damage the plastic parts.

 Do not use defrosting sprays or de-icers. These could contain substances which could damage the plastic parts or which might cause a build-up of explosive gases and pose a danger to health.

- Switch the appliance off.

The display goes out and cooling is switched off. If this does not happen, then the safety lock is still activated (see "Selecting further settings - To deactivate the safety lock").

- Disconnect it from the mains.
- Leave the freezer door open.

To speed up defrosting, two bowls of hot water (not boiling), with plates underneath them, can be placed in the freezer. Closing the door in this instance will help retain the warmth and speed up the defrosting process.

- Remove any loose particles of ice.

 Ensure that water does not get into the surrounding cabinetry.

- Use a sponge or towel to soak up the defrosted water as often as necessary.

Defrosting

After defrosting

- Clean the freezer then dry it thoroughly.
- Close the appliance door.
- Reconnect to the mains and switch the appliance back on.
- Switch on the Super freeze function so that the freezer can cool down quickly.
- Once the temperature in the freezer has reached the required temperature, place the food back in the freezer drawers and put them back in the freezer.
- When the temperature in the freezer is a constant -18°C or colder press the Super freeze button to switch the Super freeze function off.

 Do not let water get into the electronic unit or the lighting.

 Steam from a steam cleaning appliance could reach the electrical components and cause a short circuit.

Do not use a steam cleaning appliance to clean the appliance.

Cleaning water must not get into the drain hole.

The data plate located inside the appliance must not be removed. It contains information which is required in the event of a service call.

Cleaning agents

Cleaning and conditioning agents used inside the appliance must be food safe.

To avoid damaging all the surfaces of your appliance, **do not use:**

- cleaning agents containing soda, ammonia, acids or chlorides
- cleaning agents containing descaling agents
- abrasive cleaning agents, e.g. powder cleaners and cream cleaners
- solvent-based cleaning agents
- stainless steel cleaning agents
- dishwasher cleaner
- oven sprays
- glass cleaning agents
- hard, abrasive sponges and brushes, e.g. pot scourers
- melamine eraser blocks
- sharp metal scrapers

We recommend using a clean sponge, lukewarm water with a little washing-up liquid to clean surfaces of the appliance.

The following pages contain important information on cleaning.

Cleaning and care

Preparing the appliance for cleaning

- Switch the appliance off.

The display goes out and cooling is switched off.

If this does not happen, then the safety lock is still activated (see "Selecting further settings - Activating or deactivating the safety lock").

- Disconnect it from the mains.
- Take any food out of the appliance and store it in a cool place.
- Defrost the freezer (see "Defrosting").
- Take out all other removable parts for cleaning.

Cleaning the interior and accessories

Clean the appliance every time it is defrosted.

Remove soiling immediately to prevent it from drying on.

- Clean the **interior** with a clean sponge, lukewarm water and a little washing-up liquid.
- After cleaning, wipe with clean water and dry with a soft cloth.

The following parts **cannot be cleaned in a dishwasher**:

- the freezer drawers
- These accessories should all be hand washed.

The following parts **are suitable** for cleaning in a dishwasher:

The maximum temperature of the dishwashing programme selected must not exceed 55 °C.

Contact with natural dyes from carrots, tomatoes and ketchup may discolour the plastic parts in the dishwasher. This discolouration does not affect the stability of the parts.

- the adjustable shelves (with the trim and strips removed)
- the ice cube tray
- Leave the door open to air the appliance for a short while and to prevent odours building up.

Cleaning the door seal

Do not use any grease or oil on the door seal as these will cause the seal to deteriorate and become porous over time.

- The door seal should be cleaned regularly with clean water, and then wiped dry with a soft cloth.

Cleaning the ventilation gaps

A build-up of dust will increase the energy consumption of the appliance.

- The ventilation gaps should be cleaned on a regular basis with a brush or vacuum cleaner (e.g. use the dusting brush for Miele vacuum cleaners)

After cleaning

- Slide all shelves back into the appliance.
- Close the appliance door.
- Reconnect to the mains and switch the appliance back on.
- Switch on the Super freeze function so that the freezer can cool down quickly.
- Once the temperature in the freezer has reached the required temperature, place the food back in the freezer drawers and put them back in the freezer.
- When the temperature in the freezer is a constant -18°C or colder press the Super freeze button to switch the Super freeze function off.

Problem solving guide

Some minor problems can be corrected without contacting Miele.



If, having followed the suggestions below, you still cannot resolve the problem, please contact Miele.

To prevent unnecessary loss of temperature it is advisable not to open the door while waiting for the appliance to be serviced.



Unauthorised installation, maintenance and repairs can cause considerable danger for the user.

Installation, maintenance and repairs must only be carried out by a Miele authorised technician.





Problem	Cause and remedy
<p>The appliance does not get cold and the display is not lit up.</p>	<p>The appliance is not switched on and the mains connection symbol  is lit up in the display.</p> <ul style="list-style-type: none"> ■ Switch the appliance on.
	<p>The plug is not inserted in the socket correctly.</p> <ul style="list-style-type: none"> ■ Insert the plug correctly into the socket. The mains connection symbol  appears in the display when the appliance is switched off.
	<p>Check whether the mains fuse has tripped. There could be a fault with the appliance, the household electrical wiring or another electrical appliance.</p> <ul style="list-style-type: none"> ■ Contact a qualified electrician or Miele.
<p>The compressor runs continuously.</p>	<p>This is not a fault. To save energy, the compressor runs at a lower speed, but for longer, when less cooling is required.</p>
<p>The compressor is switching on more frequently and for longer periods of time. The temperature in the appliance is too low.</p>	<p>The ventilation gaps have been covered or become too dusty.</p> <ul style="list-style-type: none"> ■ Do not block the ventilation gaps. ■ Dust the ventilation gaps regularly.
	<p>The appliance door has been opened too frequently, or a large amount of fresh food has been placed inside and/or frozen at the same time.</p> <ul style="list-style-type: none"> ■ Only open the door when necessary and for as short a time as possible. <p>The required temperature will re-establish itself after a while.</p>

Problem solving guide



Problem	Cause and remedy
<p>The compressor is switching on more frequently and for longer periods of time. The temperature in the appliance is too low.</p>	<p>The door is not properly closed. A thick layer of ice may have formed in the freezer.</p> <ul style="list-style-type: none"> ■ Close the appliance door. <p>The required temperature will re-establish itself after a while.</p> <p>If a thick layer of ice has formed, it will reduce efficiency and increase the energy consumption.</p> <ul style="list-style-type: none"> ■ Defrost the appliance and clean it. <p>The ambient temperature is too high. The higher the room temperature, the longer the compressor will run for.</p> <ul style="list-style-type: none"> ■ See "Installation - Location". <p>The temperature setting is too low.</p> <ul style="list-style-type: none"> ■ Adjust the temperature. <p>A large amount of food is being frozen at once.</p> <ul style="list-style-type: none"> ■ See "Freezing and storing food". <p>The Super freeze function is still switched on.</p> <ul style="list-style-type: none"> ■ You can switch off the Super freeze function earlier to save energy.
<p>An LED indicator light is flashing at the back of the appliance at the bottom near the compressor (depending on model).</p>	<p>This is not a fault. The electronic unit for the compressor is equipped with an operation and fault diagnosis LED indicator light which flashes every 15 seconds (depending on model).</p>

Problem solving guide

Display warnings

Message	Cause and remedy
<p>"F0 to F9" appears in the display.</p>	<p>There is a fault.</p> <ul style="list-style-type: none"> ■ Call the Miele Service Department.
<p>You cannot switch the appliance off.</p>	<p>The safety lock is activated. The  symbol is lit up in the display.</p> <ul style="list-style-type: none"> ■ Deactivate the lock (see "Selecting settings - Activating or deactivating the safety lock").
<p>The Super freeze symbol  and the temperature display are flashing.</p>	<p>There is a fault.</p> <ul style="list-style-type: none"> ■ Call the Miele Service Department.
<p>The alarm symbol  and the temperature display are flashing.</p>	<p>The temperature in the appliance is too warm or too cold.</p> <p>This could be due to, for example:</p> <ul style="list-style-type: none"> - the appliance door being opened too often, or being left open. - a large quantity of fresh food being placed in the freezer at once without switching on the Super freeze function. - a lengthy interruption of the power supply. <ul style="list-style-type: none"> ■ Remedy the cause of the alarm. The alarm symbol  will go out. <p>Depending on the temperature displayed, you should check the condition of the food in the freezer. If it has defrosted or started to defrost, check that it is still safe to use and, if it is, use it as soon as possible. Defrosted food may only be refrozen after it has been cooked.</p>

Problem solving guide

Message	Cause and remedy
<p>The power failure  and  symbols appear in the display and the alarm sounds. The temperature display will also show the warmest temperature recorded in the freezer during an interruption to the power supply or a power cut.</p>	<p>The temperature in the appliance in the previous days or hours has risen too high because of a power cut or interruption to the power supply. The appliance will go back to the last temperature setting when the power is back on.</p> <ul style="list-style-type: none">■ Press the Alarm off button. <p>The warmest temperature display will go out. The display will then revert to showing the actual temperature in the freezer.</p> <ul style="list-style-type: none">■ Depending on the temperature displayed, you should check the condition of food in the freezer. If it has defrosted or started to defrost, check that it is still safe to use and, if it is, use it as soon as possible. Defrosted food may only be re-frozen after it has been cooked.
<p>The  symbol lights up in the display, the appliance does not get cold, although the appliance controls are working.</p>	<p>Demo mode is switched on. This allows the appliance to be presented in the showroom without the cooling system being switched on. Do not activate this setting for domestic use.</p> <ul style="list-style-type: none">■ Contact the Miele Service Department for information on deactivating Demo mode.

Problem solving guide

Other problems

Problem	Cause and remedy
Food has frozen together.	The food packaging was not dry when placed in the freezer. ■ Use a blunt instrument, e.g. a spoon handle or plastic scraper, to prise it apart carefully.
The external walls of the appliance feel warm.	This is not a fault. The warmth created by the evaporator is used to prevent condensation.
The door to the freezer will not open because it has been opened and closed too many times in succession.	This is not a fault. The suction caused by opening and closing the door is preventing the door from opening. Wait approx. 1 minute and then try again. It should now open without force.

Normal noises	What causes them
Brrrrr ...	A humming noise is made by the motor (compressor). This noise can get louder for brief periods when the motor switches on.
Blubb, blubb ...	A gurgling noise can be heard when coolant is circulating through the pipes.
Click ...	Clicking sounds are made when the thermostat switches the motor on and off.
Sssrrrrr ...	On multi-zone or frost-free appliances you can sometimes just hear the sound of the fan inside the appliance.
Crack ...	A cracking sound can be heard when materials expand inside the appliance.
Remember that the noise of the compressor and the coolant circulating in the system is unavoidable.	
Noises that you can easily rectify	Cause and remedy
Rattling, vibrating	The appliance is uneven. Realign the appliance using a spirit level, by raising or lowering the screw feet underneath the appliance.
	The appliance is touching another appliance or piece of furniture. Move it away.
	Drawers, baskets or shelves are unstable or sticking. Check all removable items and refit them correctly.
	Bottles or containers are touching each other. Separate them.
	The transport cable clips are hanging loose at the back of the appliance. Remove the cable clips.

After Sales / Guarantee

After sales service

In the event of any faults which you cannot easily remedy, please contact

- your Miele Dealer, or
- the Miele Service Department.

See end of this booklet for contact details. Please note that telephone calls may be monitored and recorded for training purposes and that a call-out charge will be applied to service visits where the problem could have been resolved as described in this booklet.

When contacting your Dealer or Miele, please quote the model and serial number of your appliance.

This information is given on the data plate inside your appliance.

Guarantee: U.K.

In the U.K. the appliance is guaranteed for 2 years from the date of purchase. However, you must activate your cover by calling 0330 160 6640 or registering online at www.miele.co.uk.

Guarantee: Other countries

For information on the appliance guarantee specific to your country please contact Miele.

See end of this booklet for contact details.

The appliance is supplied with a power cable and moulded plug ready for connection to an AC 230 V 50 Hz supply.

The fuse rating must be at least 10 A (13 A in the UK).

This appliance must be connected to a suitable switched socket which is easily accessible. The electrical connection must comply with current local and national safety regulations (BS 7671 in the UK).

The accessibility of the plug must always be ensured in order to be able to quickly separate the appliance from the mains.

If the mains socket is not accessible after the appliance has been built in, a separator for each terminal must be present. There must be an all-pole contact gap of at least 3 mm in the switch (including switch, fuses and relays according to EN 60335).

The plug and mains connection cable must not come into contact with the back of the appliance as vibrations can cause damage to these components. This, in turn, could result in a short circuit.

Do not plug in other appliances behind this appliance.

Do not connect the appliance to the mains electricity supply by an extension lead. Extension leads do not guarantee the required safety of the appliance (e.g. danger of overheating).

Do not connect the appliance to an inverter such as those used with an autonomous energy source e.g. **solar power**. When switched on, peak loads in the system can cause the safety switch-off mechanism to be triggered. This can damage the electronic unit. The appliance must not be used with so-called **energy-saving devices** either. These reduce the amount of energy supplied to the appliance, causing it to overheat.

If the mains cable needs to be replaced this must be done by a suitably qualified person.

Installation

This appliance must be built in, otherwise it could tip up.

Location

This appliance should not be installed where it is exposed to direct sunlight or directly adjacent to a heat-producing appliance such as an oven or a radiator. The higher the ambient temperature of the room, the more energy the appliance requires to operate. The appliance should be installed in a dry, well ventilated room.

When installing the appliance, please note:

- The socket must be easily accessible in an emergency, not concealed behind the appliance.
- The plug and cable must not touch the rear of the appliance as they could be damaged by vibrations from the appliance.
- Do not plug in other appliances behind this appliance.

 **In environments with high humidity** condensation can build up on the external appliance panels.

This can lead to corrosion of the panels.

For prevention, it is advisable to install the appliance with sufficient ventilation in a dry and/or air conditioned room.

Make sure that the appliance door closes properly, the ventilation gaps are not covered and the appliance is installed in accordance with these installation instructions.

Climate range

The appliance is designed for use within a certain climate range (ambient temperature) and should not be used outside this range.

Operating in a room which is too cold will cause the compressor to switch off for too long, causing the temperature inside the appliance to rise with the risk of food deteriorating and going off.

The climate range is stated on the data plate inside the appliance.

Climate range	Ambient room temperature
SN	+10 to +32 °C
N	+16 to +32 °C
ST	+16 to +38 °C
T	+16 to +43 °C

A freezer from the SN climate range can operate without any difficulties in rooms with a cooler ambient temperature (down to +5 °C).

Ventilation

⚠ If the ventilation gaps given are not observed, the compressor will run more frequently and for longer periods.

This will result in increased energy consumption and a higher operating temperature for the compressor. This may, in turn, cause damage to the compressor.

It is essential to observe the ventilation gaps given.

Air at the back of the appliance gets warm. The appliance housing unit must therefore be constructed to allow sufficient space for ventilation (see "Building-in dimensions"):

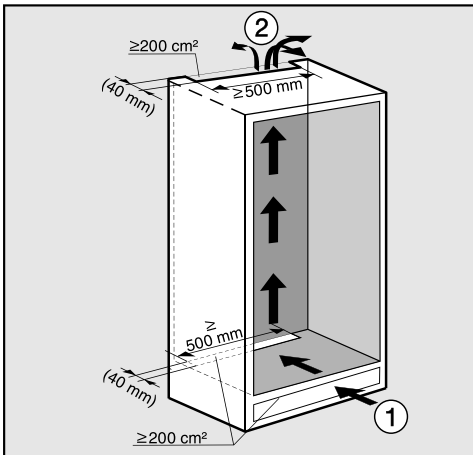

- Air intake ① occurs via the plinth at the bottom of the appliance and the air escapes at the top ② at the back of the housing unit.
- A ventilation gap of at least 40 mm depth must be allowed for behind the appliance for air to circulate.

- The ventilation cross-sections in the plinth, housing unit and above the appliance must each provide an unobstructed airflow of at least 200 cm² to ensure that air can circulate without hindrance.

If ventilation grilles are to be inserted into the ventilation gaps, the ventilation gaps must be larger than 200 cm². The unobstructed airflow of 200 cm² is calculated by adding up the total area of ventilation openings in the grille.

- Important. The appliance uses less energy, the larger the ventilation gaps.

The ventilation gaps must not be covered or blocked in any way. They should be dusted on a regular basis.

Installation

Top ventilation gap

The ventilation gap at the top of the appliance can be constructed in different ways:

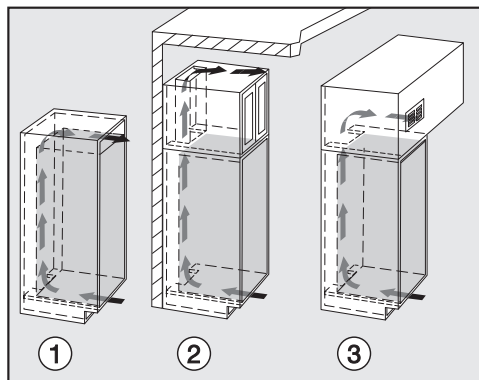

- ① directly above the appliance with a ventilation grille (free airflow of at least 200 cm²).
- ② in between the housing unit and the ceiling
- ③ through a suspended ceiling.

Before installing the appliance

- Take the accessory pack which includes installation parts and other accessories out of the appliance and remove the packaging strap holding the door in place.
- **Do not remove** the following from the back of the appliance:

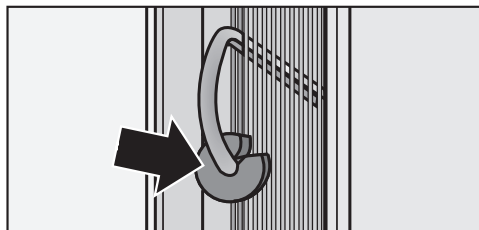

- The spacers (depending on model). These ensure the gap required between the back of the appliance and the wall is maintained.
- Depending on model, the pouches located in the metal grille (heat exchanger). They are required for the correct functioning of the appliance. The contents are not poisonous or dangerous.
- Remove the cable clip from the back of the appliance.
- Check that all parts at the back of the appliance are unhindered. Carefully remove any hindrance.

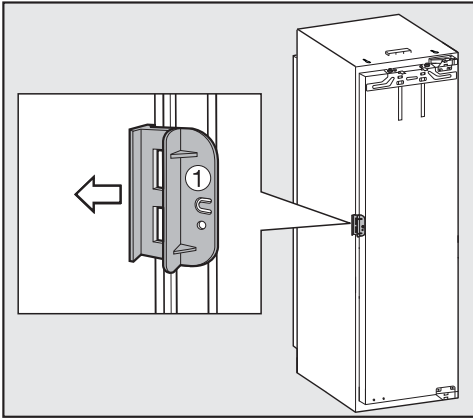

- Open the appliance door and remove the red safety catch ① (depending on model).

Does your old appliance have a different hinging mechanism?

If your old appliance had a different type of hinging, the furniture door can still be used. Remove the old hinges from the housing unit. They are no longer required because the furniture door is now fitted to the appliance door. All the necessary parts are supplied or can be ordered from Miele.

Stainless steel front

(depending on model)

If your old appliance had different hinging and you cannot, or do not wish to use your old door, you can use a stainless steel front instead.

Contact Miele for information on suitable stainless steel fronts.

Building-in dimensions

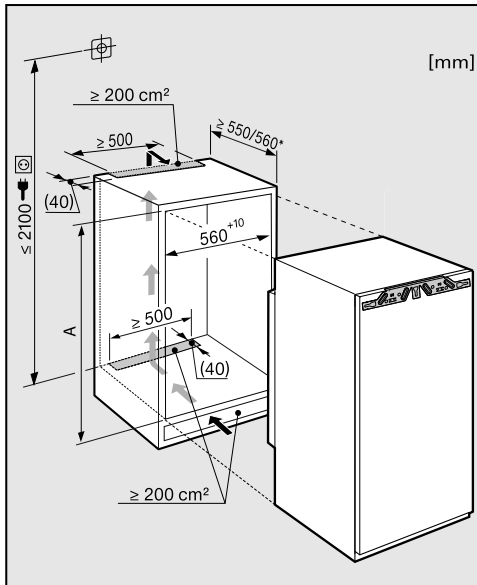

* The declared energy consumption was calculated in a 560 mm deep niche. The appliance is fully functional in a 550 mm niche but the energy consumption will be slightly higher.

Before installation, ensure the housing unit is the correct size. The specified ventilation cross-sections must be maintained in order to ensure the correct functioning of the appliance.

	Niche height [mm] A
F 32202 i	874 – 890

Changing the door hinging

Changing the door hinging

Two people are needed for changing the door hinging.

The appliance is supplied right-hand hinged. If left-hand hinging is required, the hinges must be changed.

To change the door hinging, you will need the following tools:

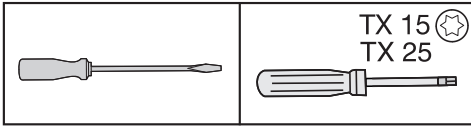

- Open the appliance door.
- Remove the shelves/bottle shelf from the appliance door.

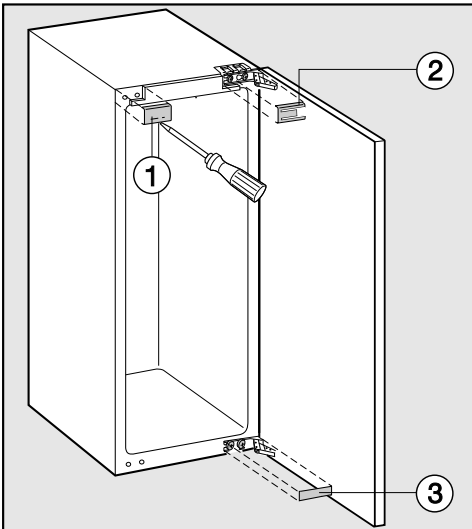

- Lift off covers ①, ② and ③.

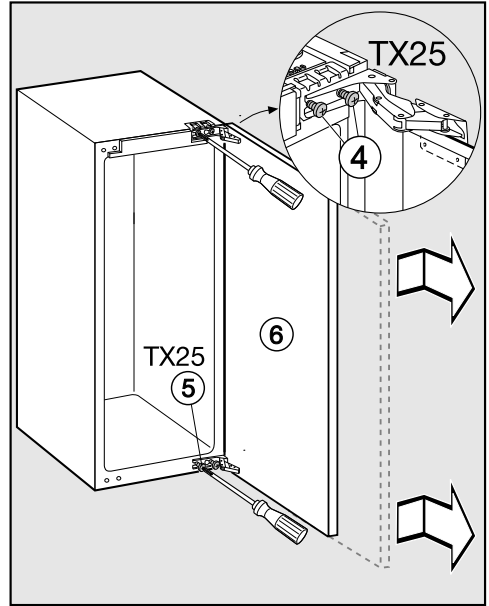

- Slightly loosen screws ④ and ⑤ in the hinges.
- Push door ⑥ outwards and take it off its hinges.

Changing the door hinging

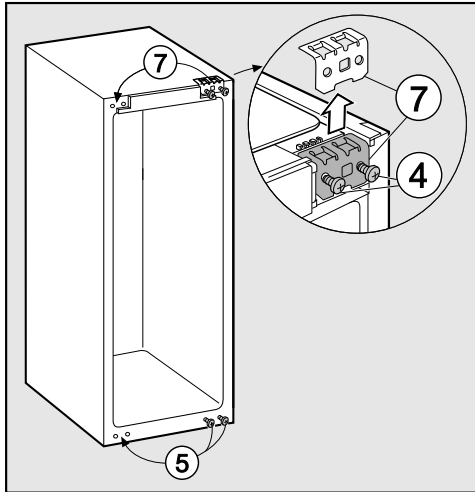

- Undo screws ④ completely.
- Fit bracket ⑦ on the opposite side and loosely fit screws ④.
- Remove screws ⑤ completely and loosely screw them in on the opposite side.

If you have put locking pins into the hinges to stop the door opening too far:

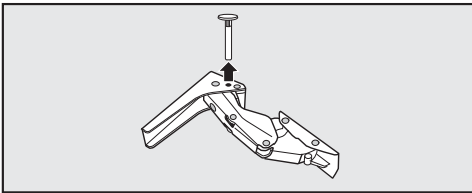

- Remove the locking pins from the top of the hinges.

Refitting the door

- Place the door with the outer side upwards on a stable surface.

**⚠ Danger of injury.
Do not close the hinges.**

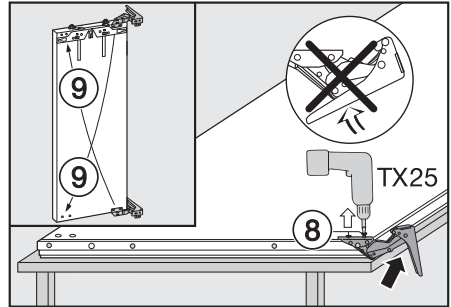

- Remove screws ⑧ completely.
- Replace the hinges in their diagonally opposite corners ⑨.

Changing the door hinging

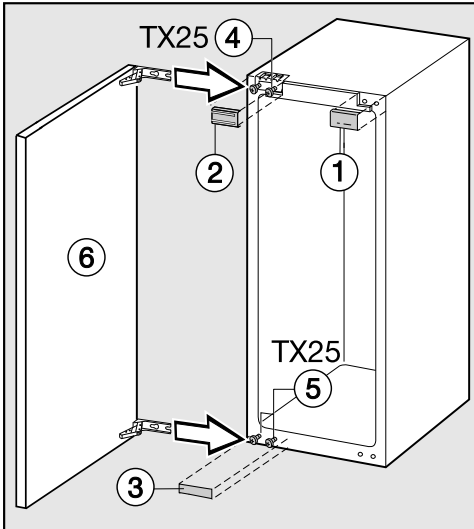

- Hang appliance door ⑥ onto pre-fitted screws ④ and ⑤, and tighten screws ④ and ⑤ securely.
- Replace covers ①, ② and ③.

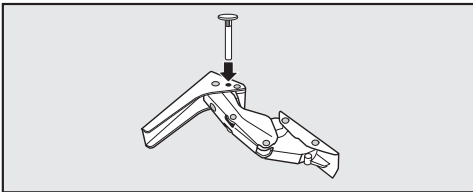

- Refit the locking pins into the top of the hinges to prevent the doors opening too far.

Installing the appliance

Two people are required for installing the appliance.

- Install the appliance in a stable, solid housing unit, positioned on an even and level floor.
- Secure the housing unit against tipping.

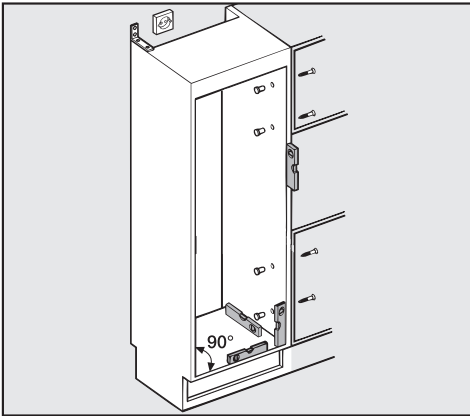

- Use a spirit level to align the housing unit. The corners of the housing unit must be at a 90 ° angle to each other, otherwise the furniture door will not align correctly with all 4 corners of the housing unit.
- The required ventilation cross-sections must be ensured (see "Installation - Ventilation" and "Building-in dimensions").

To install the appliance, you will need the following tools:

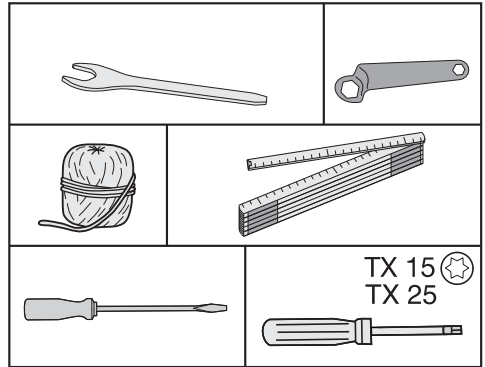

Installing the appliance

Parts required for installation

All installation parts are number coded. This coding is also used in the installation instructions.

– required for installing the appliance in its housing unit:

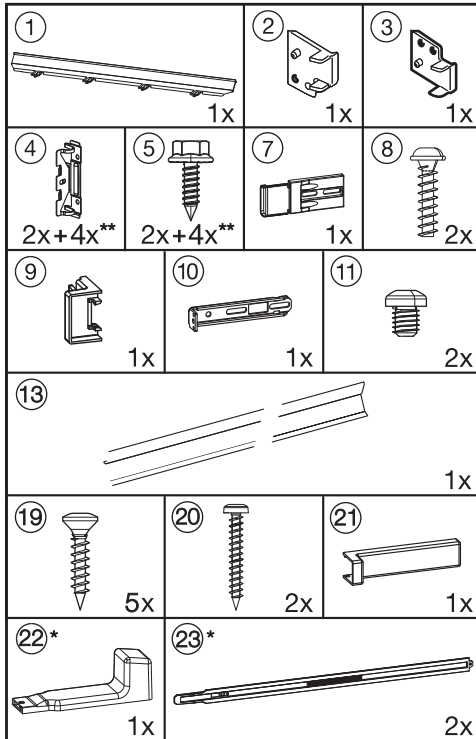

* These parts are only supplied with appliances with a niche height of 140 cm or more.

** Number depending on niche height. Also contains additional installation parts for fitting large or divided furniture doors.

– required for fitting the furniture door:

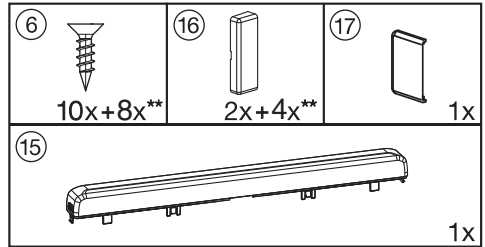

** Number depending on niche height. Also contains additional installation parts for fitting large or divided furniture doors.

All fitting instructions given are for a **right-hand hinged** appliance. If you have converted the appliance to left-hand hinging, you will need to adapt these instructions accordingly.

Installing the appliance

Preparing the appliance

- Position the appliance in front of the housing unit.

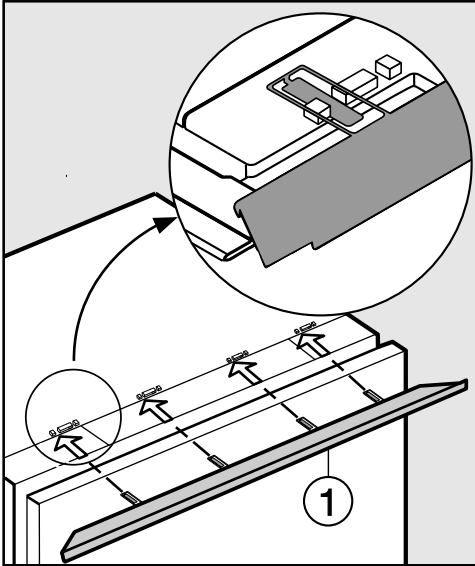

- Fit cover strip ① into position.

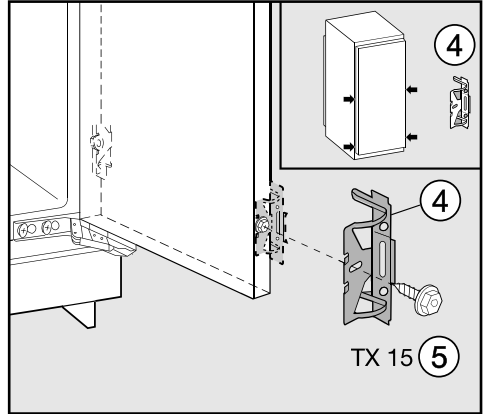

- Screw fixing bracket ④ using hex screw ⑤ to the pre-drilled holes in the appliance door. Using the pre-drilled holes in the appliance door, secure a second pair of fixing brackets ④ in the handle area of the door.
- Push the appliance two-thirds of the way into its niche. When doing this, make sure that the mains cable does not get trapped.

Tip: To help you push it into position, tie a piece of string around the plug to "increase" the length of the connection cable.

Then pull the cable by the end of the string through the housing unit. It will then be easier to connect once the appliance is in the unit.

Installing the appliance

With 16 mm thick unit walls:

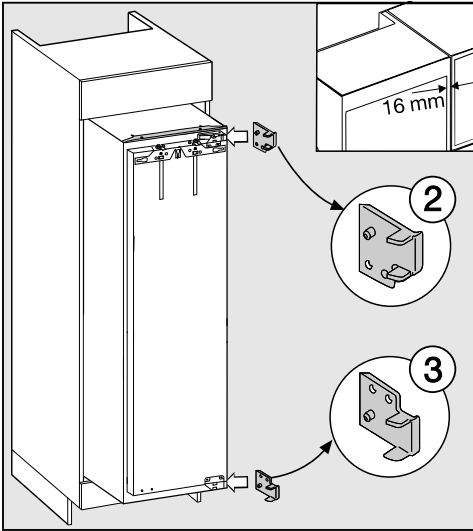

- Clip spacers ② and ③ on the right-hand side of the hinges.
- Open the appliance door.

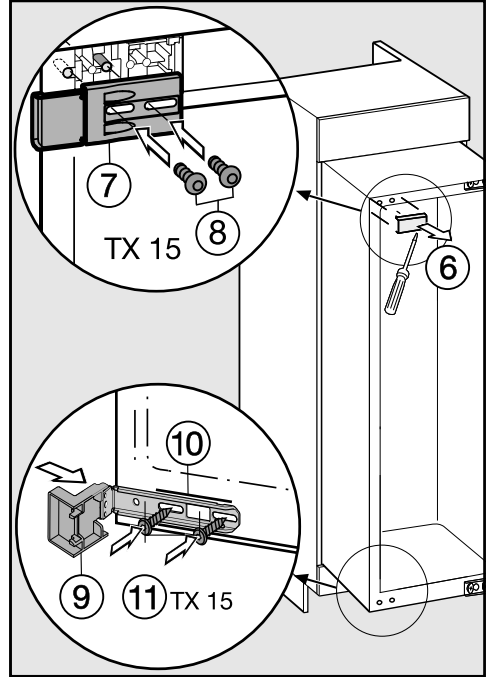

- Remove cover ⑥.
- Secure part ⑦ using screws ⑧ loosely into the top left-hand side of the appliance. Do not tighten the screws so that you can adjust the position of this part.
- Fit stopper ⑨ onto fixing bracket ⑩.
- Then screw fixing bracket ⑩ using screws ⑪ loosely into the bottom of the appliance. Do not tighten the screws so that you can adjust the position of this part.

Installing the appliance

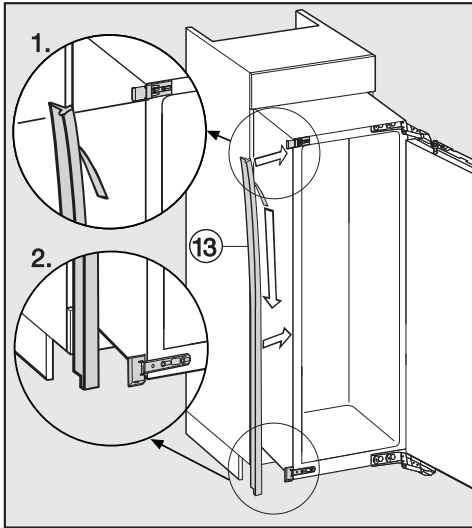

- Carefully remove the protective foil from sealing strip ⑬.
- Fix sealing strip ⑬ flush with the front of the appliance on the door opening side.

1. Position the sealing strip flush with the lower edge of the top fixing.
2. Stick it down along its entire length.

Installing the appliance.

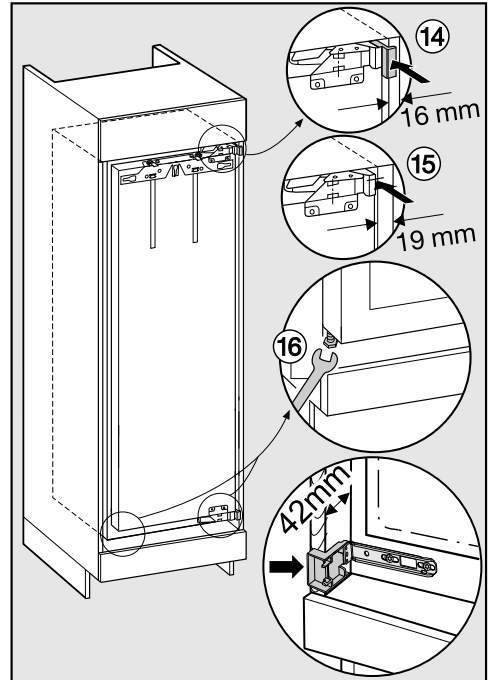

- Push the appliance into the niche until all fixing brackets are in line with the front edge of the furniture side wall.
 - ⑭ **With 16 mm thick walls:**
The spacers should touch the front edge at the top and bottom of the side walls of the housing unit.
 - ⑮ **With 19 mm thick walls:**
The front edges of the top and bottom hinges should be flush with the front edge of the housing side wall.

Installing the appliance

- Check the position of the fixing bracket at the top and bottom front edge of the furniture side wall again.

This will create a gap all round of **42 mm** to the front edges of the housing unit side walls.

On furniture with door fittings (e.g. stubs, seals etc.) the dimension of these must be taken into account when making sure there is a gap all round of **42 mm**.

- Pull the appliance forwards by the appropriate dimension.

The hinges and covers will now protrude by the dimension of the door fitting.

Tip: Remove the door fittings. This will ensure that the door is flush with the surrounding kitchen unit furniture doors.

- ⑩ Align the appliance on both sides by altering the adjustable feet using the spanner supplied.

If the all round gap of 42 mm is not maintained between the appliance housing and the front edge of the housing unit side wall, the door may not shut properly.

This can cause ice to build up, condensate to accumulate and lead to faults in the appliance. These can all lead to increased energy consumption.

Securing the appliance in the niche

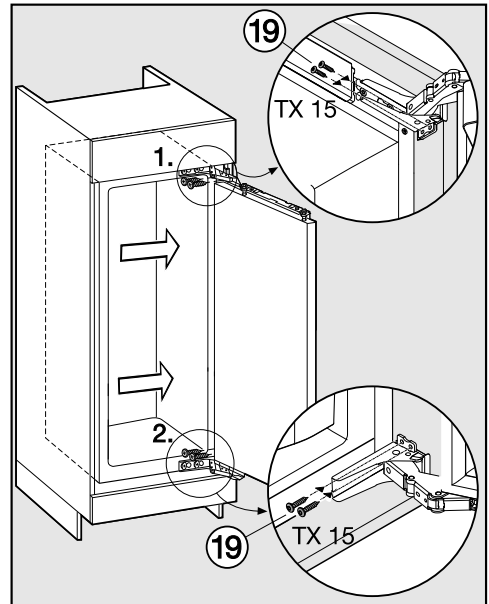

- Press the appliance against the side of the housing unit on the hinge side.
- Screw chipboard screws ⑩ through the hinge plates at the top and bottom to secure the appliance to the housing unit.

Installing the appliance

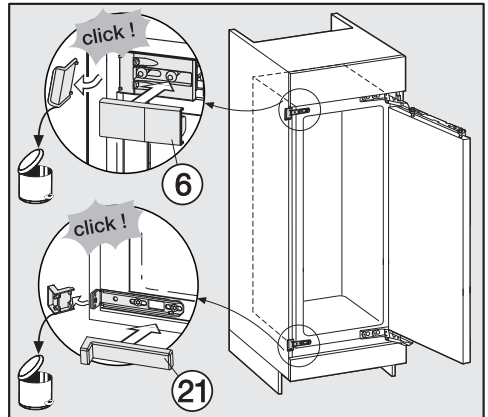
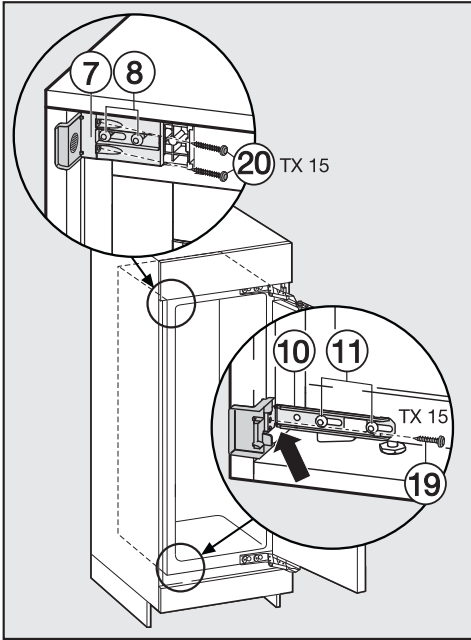

- Push the loose bracket against the furniture wall.
- Secure fixing bracket ⑩ to the housing unit side wall with screw ⑲. Drill holes in the housing unit side walls if necessary.
- Secure fixing bracket ⑦ to the housing unit side walls using screws ⑳. Drill holes in the housing unit side walls if necessary.
Important: Push the protruding bracket using your thumb towards the housing unit wall whilst tightening the screws. The appliance must not pull back into the unit.
- Re-tighten screws ⑧ and ⑪.

- Snap off any protruding ends from the fixing bracket. They are no longer required.
- Replace covers ⑥ and ⑳ on the fixing brackets.

Only for an appliance with a niche height greater than 140 cm

For additional stability of the appliance in the unit, push the rods supplied underneath the appliance between it and the floor of the housing unit:

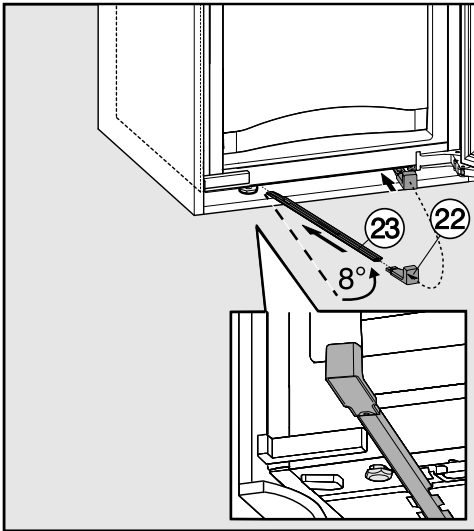

- Then secure handle ②② to one of the rods ②③.
- Use the handle to push the rod into the guide as far as it will go. Remove the handle and fit it to the other rod and push this into its guide as far as it will go.
Important. Keep the handle somewhere safe in case you ever need to fit the appliance into a new housing unit.
- Close the appliance door.

Fitting the furniture door

The furniture door must be at least 16 mm thick and not exceed 19 mm thick.

The following gap dimensions must be maintained:

- The gap between the furniture door and the unit door above must be at least 3 mm.
- The vertical gap between furniture doors should also be about 3 mm. The exact dimension will vary depending on the radius of the furniture door edges.

If fitted in a run of units make sure that the top edge of the furniture door is at the same height as neighbouring unit doors.

The furniture door must be fitted correctly and not under tension.

Installing the appliance

Fitting a door front which is heavier than the maximum permitted could damage the hinges. This can cause subsequent functional problems.

Before fitting a furniture door, ensure that the weight of the door does not exceed the maximum permitted:

Appliance	Maximum weight of furniture door in kg
F 32202 i	16

When fitting large or divided furniture doors an extra fitting kit or set of fixing brackets should be used. These are available to order from Miele.

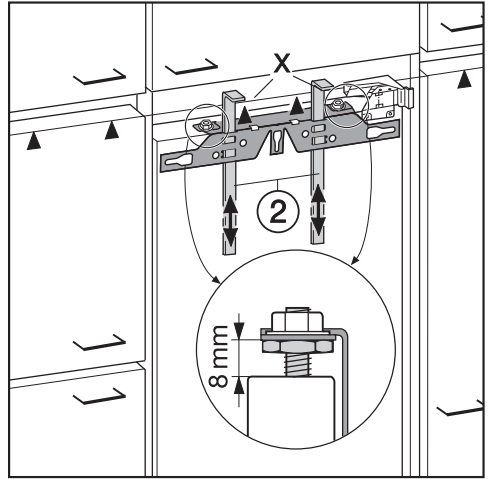

- A gap of 8 mm is set ex-works between the appliance door and the fixing bracket. Double check this gap and reset it if necessary.
- Push fitting aids ② up to the height of the furniture door: the lower edge X of the fitting aids must be at the same height as the upper edge of the furniture door being fitted (see ▲ on the diagram).

Installing the appliance

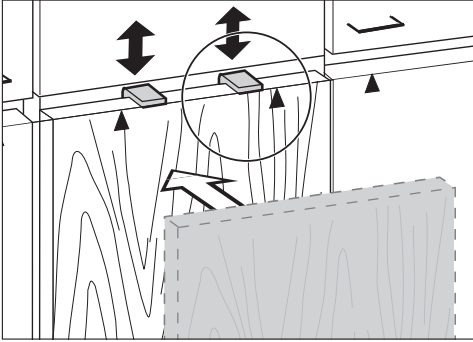

Tip: Push fitting aids ② together with the furniture front up to the height of the adjoining unit furniture doors.

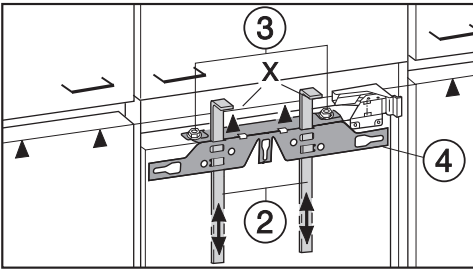

- Undo nuts ③ and take fixing bracket ④ off together with fitting aids ②.

- Place the furniture door with the outer side downwards on a stable surface.

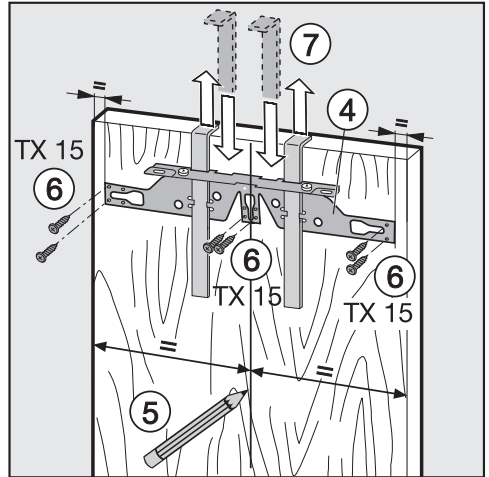

- Using a pencil, lightly mark a line down the centre of the inside of the furniture door ⑤.
- Hang fixing bracket ④ with the fitting aids onto the **inside** of the furniture door. Align the fixing bracket centrally.
- Attach the fixing bracket securely using at least 6 short chipboard screws ⑥. (On cassette doors only use 4 screws on the edges). Drill holes in the furniture door if necessary.
- Pull the fitting aids upwards to remove them ⑦.
Turn them around and fit them into the middle slots on the fixing bracket for safe keeping.

Installing the appliance

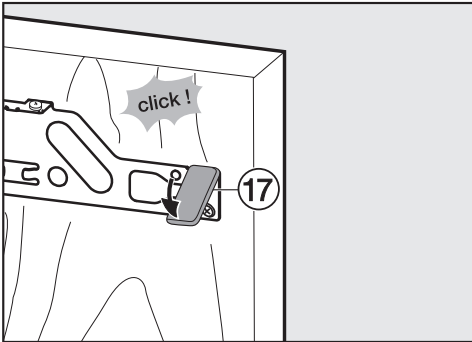

- Fit side cover ⑰ to the fixing bracket on the opposite side of the hinge.
- Turn the furniture door over and attach the handle (if required).

- Open the appliance door.

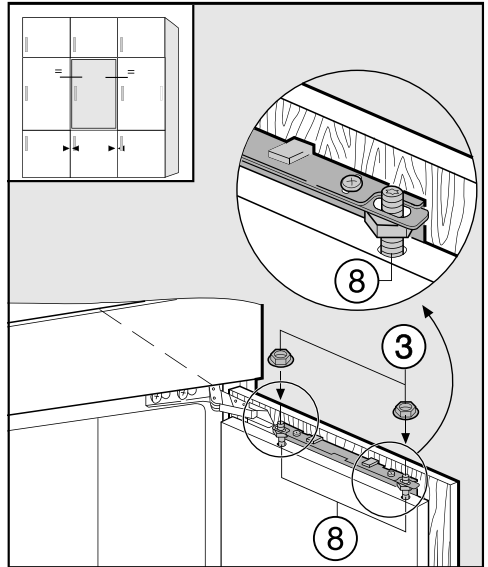

- Hang the furniture door onto adjusting bolts ⑧.
- Loosely attach nuts ③ on the adjusting bolts.
- Close the door and check the distance between the door and neighbouring furniture doors. The gaps should be even.

Installing the appliance

Aligning the door

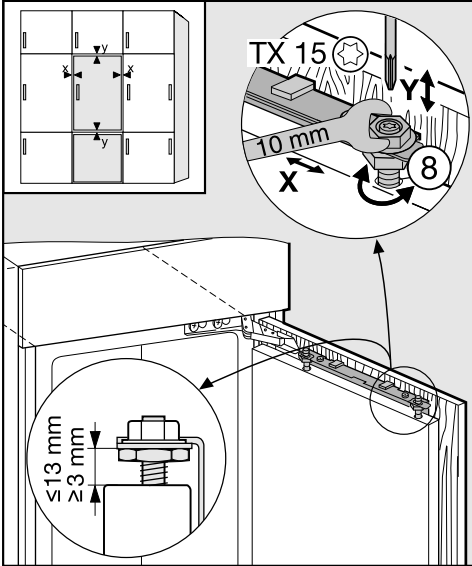

- Side adjustments (X)

- Slide the furniture door.

- Height adjustment (Y)

- Use a screwdriver to adjust bolts (8).

A gap of 8 mm is set ex-works between the appliance door and the fixing bracket. This must only be adjusted within its permitted range.

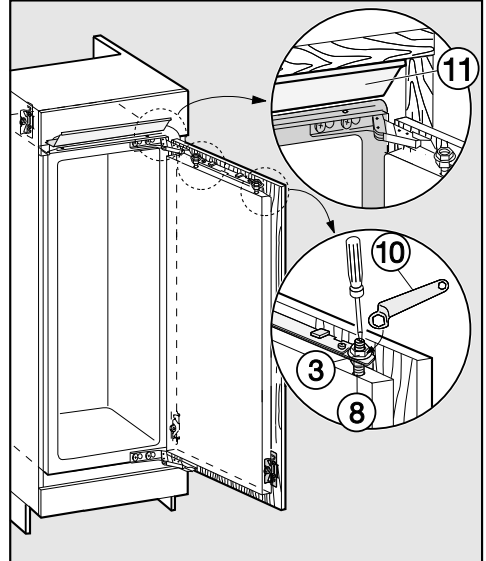

- Whilst counterholding adjusting bolts (8) with a screwdriver, tighten nuts (3) on the appliance door with ring spanner (10).
- Cover strip (11) must be completely hidden in the niche, and must not protrude.

Installing the appliance

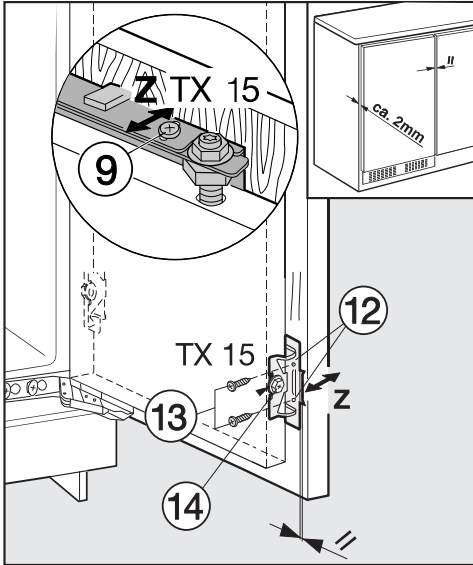

- Drill holes ⑫ in the furniture door and fit screws ⑬. Make sure the two metal edges are aligned (Symbol //).
- Close the appliance door and the furniture door.

- Depth adjustment (Z)

- Loosen screws ⑨ at the top of the appliance door, and screw ⑭ on the fixing bracket at the bottom. By moving the furniture door, create a gap of 2 mm between the furniture door and the housing unit.

- Tighten all screws again.

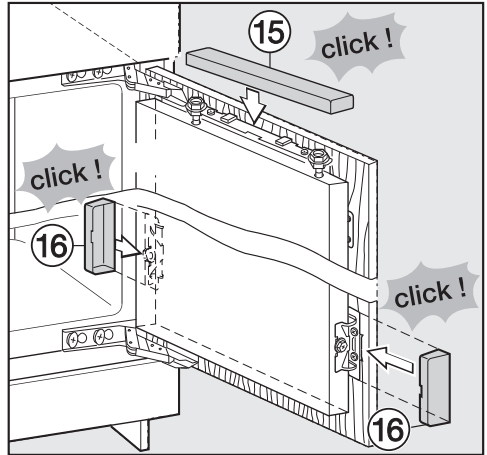

- Replace top cover ⑮, and click it into place.

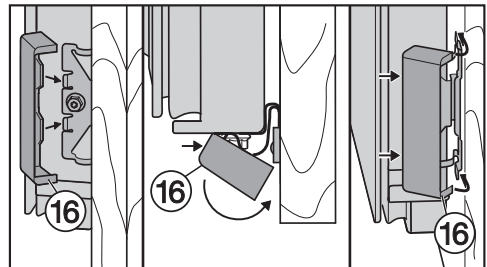

- Replace side covers ⑯, making sure you hear them click into place.

To make sure the appliance is correctly fitted:

- The door must close properly.
- The door must not touch the housing unit.
- The seal at the top edge of the handle side must fit properly.
- To double check place a torch in the appliance and close the door. Turn the lights out in the room. If you can see any light shining out from the sides double check the installation.

United Kingdom

Miele Co. Ltd.
Fairacres, Marcham Road
Abingdon, Oxon, OX14 1TW
Customer Contact Centre Tel: 0330 160 6600
E-mail: mielecare@miele.co.uk
Internet: www.miele.co.uk

Australia

Miele Australia Pty. Ltd.
ACN 005 635 398
ABN 96 005 635 398
1 Gilbert Park Drive, Knoxfield, VIC 3180
Tel: 1300 464 353
Internet: www.miele.com.au

China

Miele (Shanghai) Trading Ltd.
1-3 Floor, No. 82 Shi Men Yi Road
Jing' an District
200040 Shanghai, PRC
Tel: +86 21 6157 3500, Fax: +86 21 6157 3511
E-mail: info@miele.cn, Internet: www.miele.cn

Miele (Hong Kong) Limited

41/F - 4101, Manhattan Place
23 Wang Tai Road
Kowloon Bay, Hong Kong
Tel: (852) 2610 1331, Fax: (852)2610 1013
Email: mielehk@miele.com.hk

India

Miele India Pvt. Ltd.
Ground Floor, Copia Corporate Suites
Plot No. 9, Jasola
New Delhi - 110025
Tel: 011-46 900 000, Fax: 011-46 900 001
E-mail: customercare@miele.in, Internet: www.miele.in

Ireland

Miele Ireland Ltd.
2024 Bianconi Avenue
Citywest Business Campus, Dublin 24
Tel: (01) 461 07 10, Fax: (01) 461 07 97
E-Mail: info@miele.ie, Internet: www.miele.ie

Manufacturer: Miele & Cie. KG

Carl-Miele-Straße 29, 33332 Gütersloh, Germany

Miele

Malaysia

Miele Sdn Bhd
Suite 12-2, Level 12
Menara Sapura Kencana Petroleum
Solaris Dutamas No. 1, Jalan Dutamas 1
50480 Kuala Lumpur, Malaysia
Phone: +603-6209-0288
Fax: +603-6205-3768

New Zealand

Miele New Zealand Limited
IRD 98 463 631
Level 2, 10 College Hill
Freemans Bay, Auckland 1011, NZ
Tel: 0800 464 353
Internet: www.miele.co.nz

Singapore

Miele Pte. Ltd.
163 Penang Road
04 - 03 Winsland House II
Singapore 238463
Tel: +65 6735 1191, Fax: +65 6735 1161
E-Mail: info@miele.com.sg
Internet: www.miele.sg

South Africa

Miele (Pty) Ltd
63 Peter Place, Bryanston 2194
P.O. Box 69434, Bryanston 2021
Tel: (011) 875 9000, Fax: (011) 875 9035
E-mail: info@miele.co.za
Internet: www.miele.co.za

United Arab Emirates

Miele Appliances Ltd.
P.O. Box 11 47 82
Gold & Diamond Park, Sheikh Zayed Road
Building 6 / Offices Nos. 6-214 to 6-220
Dubai
Tel: +971-4-341 84 44
Fax: +971-4-341 88 52
E-Mail: info@miele.ae
Internet: www.miele.ae

F 32202 i



en-GB

M.-Nr. 10 090 670 / 01