

CABLE CONNECTIONS

DISCO DE ADMINISTRACIÓN DE CABLES
CONNEXIONS DE CABLES
KABELVERBINDUNGEN
COLLEGAMENTI DEI CAVI
LIGAÇÕES DE CABOS
ПОДКЛЮЧЕНИЕ КАБЕЛЕЙ
케이블 연결
ケーブル接続
線路连接
線路连接

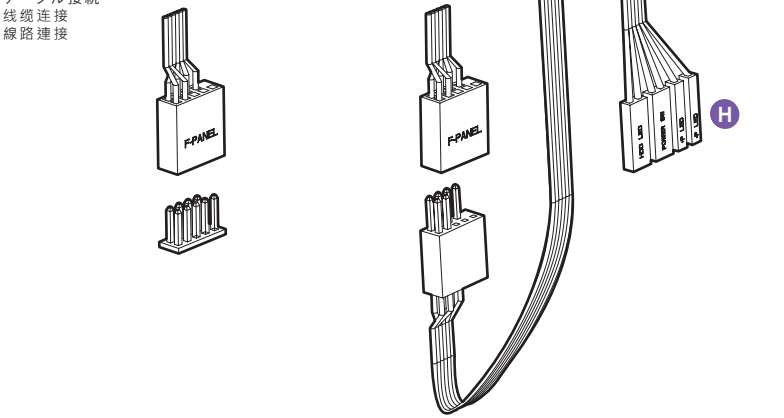

FOR INTEL STANDARD F_PANEL HEADER USE FOR NON-INTEL STANDARD F_PANEL HEADER USE



EXPANSION CARD INSTALLATION

INSTALACIÓN DE LA TARJETA DE EXPANSIÓN
INSTALLATION DE LA CARTE D'EXTENSION
INSTALLATION DER ERWEITERUNGSKARTE
INSTALLAZIONE DELLA SCHEDE D'ESPANSIONE
INSTALAÇÃO DA PLACA DE EXPANSÃO
УСТАНОВКА ПЛАТЫ РАСШИРЕНИЯ
확장 카드 설치
拡張カードの装着
擴充卡安裝

UNSCREW THE THUMB SCREW

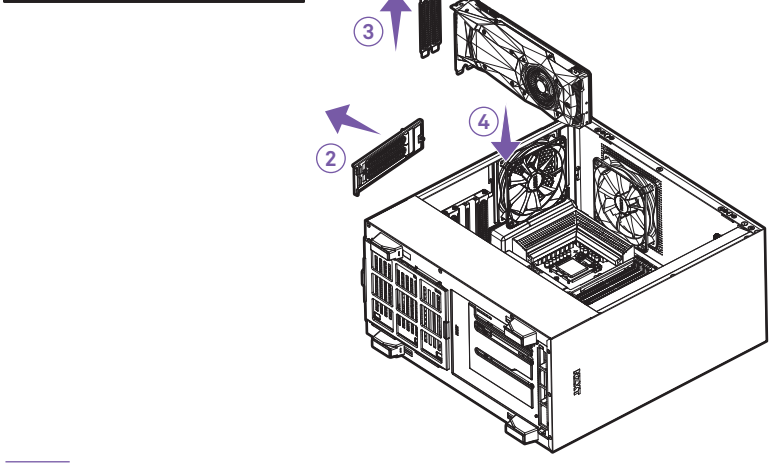
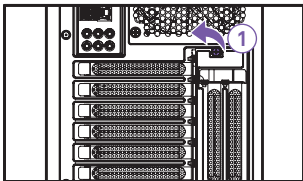

HORIZONTAL GPU MOUNT

FAN AND RADIATOR SUPPORT

COMPATIBILIDAD DE VENTILADORES Y RADIADORES
PRISE EN CHARGE DES RADIATEURS ET VENTILATEURS
LÜFTER- UND KÜHLER-UNTERSTÜTZUNG
SUPPORTO VENTOLE E RADIATORE
SUPPORTO PARA VENTONINHA E A RADIADOR
СОВМЕСТИМЫЕ РАДИАТОР И ВЕНТИЛЯТОР
팬 및 라디에이터 지원
対応ファンおよびラジエータ
風扇散热器支持
風扇散热器支援

RADIATOR MODE

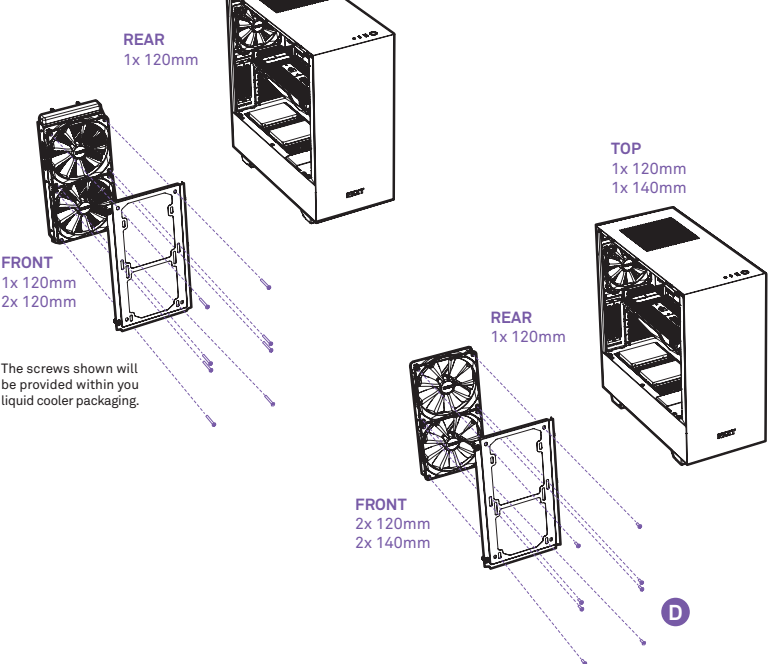

BUTTONS AND I/O

BOTONES Y E/S
BOUTTONS ET E/S
TASTEN UND E/A
PULSANTI E I/O
BOTÕES E E/S
КНОПКИ И РАЗЪЕМЫ ВВОДА/ВЫВОДА
버튼 및 I/O
ボタンおよび I/O
按钮和 I/O
按钮和 I/O

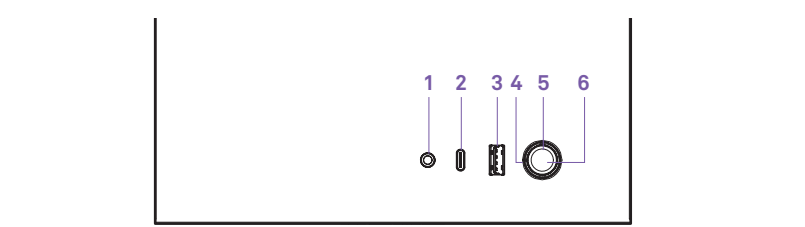

1. HD Audio Output	1. Salida audio HD	1. HDオーディオ
2. USB 3.1 Gen2 Type-C <td>2. USB 3.1 Gen2 Type-C<td>2. USB 3.1 Gen2 Type-C</td></td>	2. USB 3.1 Gen2 Type-C <td>2. USB 3.1 Gen2 Type-C</td>	2. USB 3.1 Gen2 Type-C
3. USB 3.1 Gen1 Type-A <td>3. USB 3.1 Gen1 Type-A<td>3. USB 3.1 Gen1 Type-A</td></td>	3. USB 3.1 Gen1 Type-A <td>3. USB 3.1 Gen1 Type-A</td>	3. USB 3.1 Gen1 Type-A
4. HDD LED <td>4. LED HDD<td>4. HDD LED</td></td>	4. LED HDD <td>4. HDD LED</td>	4. HDD LED
5. Power LED <td>5. LED alimentazione<td>5. パワーLED</td></td>	5. LED alimentazione <td>5. パワーLED</td>	5. パワーLED
6. Power switch <td>6. Interruttore d'alimentazione<td>6. 電源スイッチ</td></td>	6. Interruttore d'alimentazione <td>6. 電源スイッチ</td>	6. 電源スイッチ

1. Salida de audio HD	1. Звуковий вихід HD	1. 高音質オーディオ
2. USB 3.1 Gen2 Type-C <td>2. USB 3.1 Gen2 Type-C<td>2. USB 3.1 Gen2 Type-C</td></td>	2. USB 3.1 Gen2 Type-C <td>2. USB 3.1 Gen2 Type-C</td>	2. USB 3.1 Gen2 Type-C
3. USB 3.1 Gen1 Type-A <td>3. USB 3.1 Gen1 Type-A<td>3. USB 3.1 Gen1 Type-A</td></td>	3. USB 3.1 Gen1 Type-A <td>3. USB 3.1 Gen1 Type-A</td>	3. USB 3.1 Gen1 Type-A
4. LED de unidad de disco duro <td>4. LED do HDD<td>4. HDD LED</td></td>	4. LED do HDD <td>4. HDD LED</td>	4. HDD LED
5. LED de alimentación <td>5. LED de alimentação<td>5. 電源LED</td></td>	5. LED de alimentação <td>5. 電源LED</td>	5. 電源LED
6. Interruptor de encendido <td>6. Interruptor de alimentação<td>6. 電源開閉</td></td>	6. Interruptor de alimentação <td>6. 電源開閉</td>	6. 電源開閉

1. Sortie audio HD	1. Звуковий вихід HD	1. 高音質オーディオ
2. USB 3.1 Gen2 Type-C <td>2. USB 3.1 Gen2 Type-C<td>2. USB 3.1 Gen2 Type-C</td></td>	2. USB 3.1 Gen2 Type-C <td>2. USB 3.1 Gen2 Type-C</td>	2. USB 3.1 Gen2 Type-C
3. USB 3.1 Gen1 Type-A <td>3. USB 3.1 Gen1 Type-A<td>3. USB 3.1 Gen1 Type-A</td></td>	3. USB 3.1 Gen1 Type-A <td>3. USB 3.1 Gen1 Type-A</td>	3. USB 3.1 Gen1 Type-A
4. LED de unidad de disco duro <td>4. LED do HDD<td>4. HDD LED</td></td>	4. LED do HDD <td>4. HDD LED</td>	4. HDD LED
5. LED de alimentación <td>5. LED de alimentação<td>5. 電源LED</td></td>	5. LED de alimentação <td>5. 電源LED</td>	5. 電源LED
6. Interrupteur marche/arrêt <td>6. Выключатель питания<td>6. 電源開閉</td></td>	6. Выключатель питания <td>6. 電源開閉</td>	6. 電源開閉

1. HD-Audioausgang	1. HD 오디오 출력	1. 高音質オーディオ
2. USB 3.1 Gen2 Type-C <td>2. USB 3.1 Gen2 Type-C<td>2. USB 3.1 Gen2 Type-C</td></td>	2. USB 3.1 Gen2 Type-C <td>2. USB 3.1 Gen2 Type-C</td>	2. USB 3.1 Gen2 Type-C
3. USB 3.1 Gen1 Type-A <td>3. USB 3.1 Gen1 Type-A<td>3. USB 3.1 Gen1 Type-A</td></td>	3. USB 3.1 Gen1 Type-A <td>3. USB 3.1 Gen1 Type-A</td>	3. USB 3.1 Gen1 Type-A
4. Festplatten-LED <td>4. HDD LED<td>4. HDD LED</td></td>	4. HDD LED <td>4. HDD LED</td>	4. HDD LED
5. Betriebs-LED <td>5. 電源LED<td>5. 電源LED</td></td>	5. 電源LED <td>5. 電源LED</td>	5. 電源LED
6. Netzschalter <td>6. 전원 스위치<td>6. 전원 스위치</td></td>	6. 전원 스위치 <td>6. 전원 스위치</td>	6. 전원 스위치

PANEL REMOVAL

EXTRACCIÓN DE PANEL
RETRAIT DU PANNEAU
BLLENDE ENTFERNEN
RIMOZIONE DEL PANNELLO
REMOÇÃO DOS PAINÉIS
СНЯТИЕ ПАНЕЛИ
面板拆卸
パネルの取り外し
卸下面板
移除面板

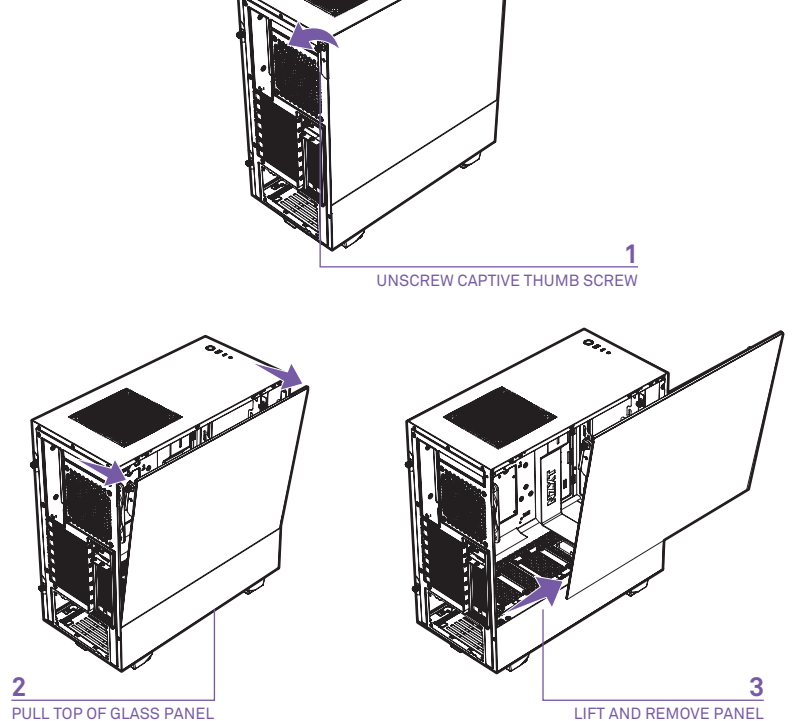

HDD DRIVE INSTALLATION

INSTALACIÓN DE LA UNIDAD DE DISCO DURO
INSTALLATION DE LECTEUR HDD
HDD-LAUFWERKSINSTALLATION
INSTALLAZIONE DELL'UNITÀ HDD
INSTALAÇÃO DA PLACA DE EXPANSÃO
УСТАНОВКА ЖЕСТКОГО ДИСКА
HDD 드라이브 설치
HDD裝載
HDD 驱动器安裝
硬盤安裝

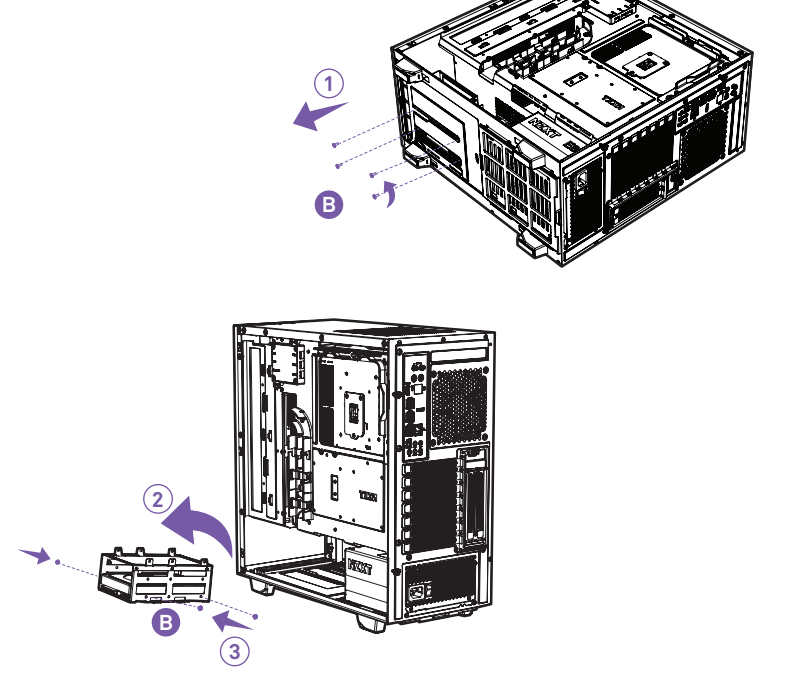

CABLE MANAGEMENT SYSTEM

SISTEMA DE GESTIÓN DE CABLES
SYSTÈME DE CÂBLAGE
KABELMANAGEMENTSYSTEM
SISTEMA DI GESTIONE DEI CAVI
SISTEMA DE GERENCIAMENTO DE CABOS
СИСТЕМА ПРОКЛАДКИ КАБЕЛЕЙ
케이블 정리 시스템
ケーブルマネジメントシステム
理線管理系統
配線管理系統

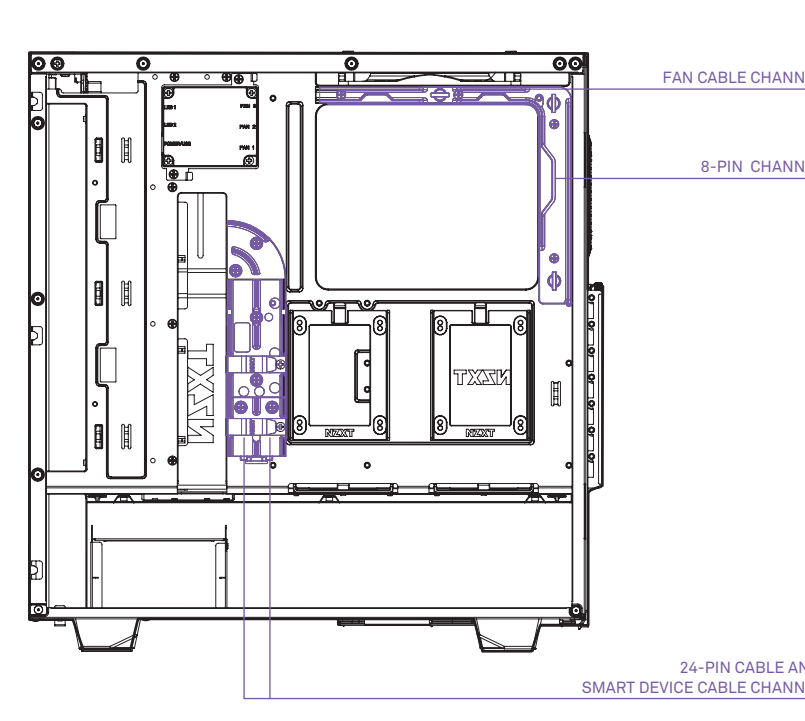

MOTHERBOARD INSTALLATION

INSTALACIÓN DE LA PLACA BASE
INSTALLATION DE LA CARTE MÈRE
INSTALLATION DER HAUPTPLATINE
INSTALLAZIONE DELLA SCHEDE MADRE
INSTALAÇÃO DA PLACA PRINCIPAL
УСТАНОВКА СИСТЕМНОЙ ПЛАТЫ
마더보드 설치
マザーボードの装着
主板安裝
主機板安裝

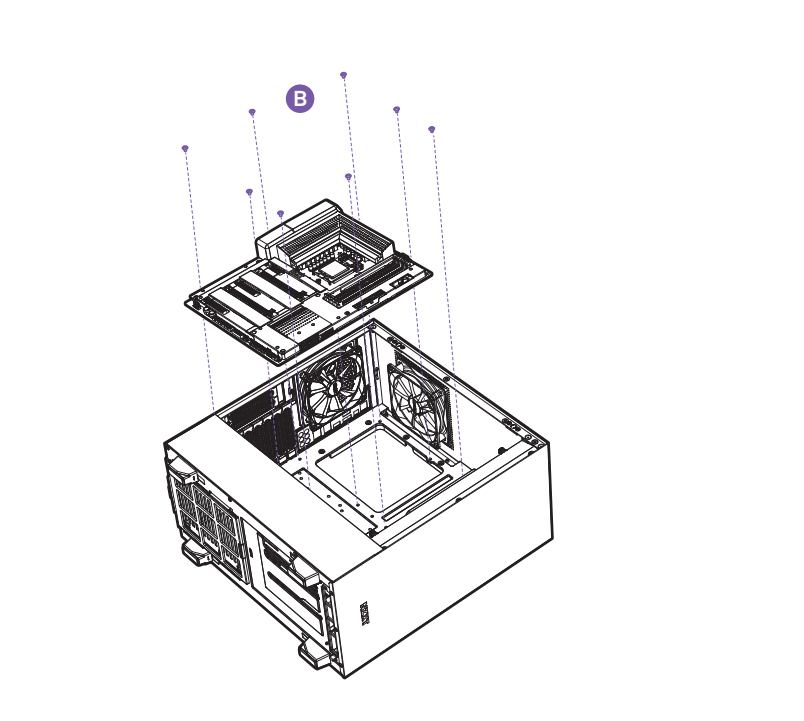

POWER SUPPLY INSTALLATION

INSTALACIÓN DE LA FUENTE DE ALIMENTACIÓN
SUPPORT DE REFRIGÉRISEMENT LIQUIDE
INSTALLATION DER STROMVERSORGUNG
INSTALLAZIONE DELL'ALIMENTATORE
INSTALAÇÃO DA FONTE DE ALIMENTAÇÃO
УСТАНОВКА ИСТОЧНИКА ПИТАНИЯ
전원 공급 장치 설치
電源の装着
電源安裝
電源安裝

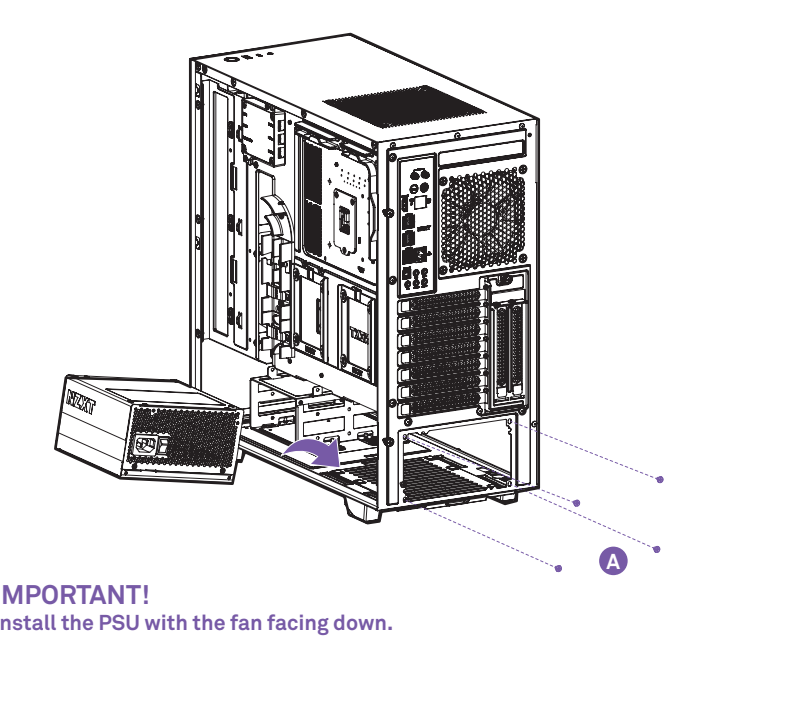

DIY LIQUID COOLER INSTALLATION

HAZLO TÚ MISMO: SOPORTE PARA REFRIGERADOR LÍQUIDO
SUPPORTE DE REFRIGÉRISEMENT LIQUIDE
VOUS-MÊME
WASSERKÜHLUNG MARKE EIGENBAU
SUPPORTE PER DISSIPATORE A LIQUIDO FAI-DA-TE
SUPPORTE A REFRIGERAZIONE LIQUIDA DIY
ПОДДЕРЖКА САМОСТОЯТЕЛЬНОЙ СБОРКИ ЖИДКОСТНОЙ СИСТЕМЫ ОХЛАЖДЕНИЯ
DIY 수냉식 열교환기 지원
水冷クーラーサポートの DIY
SSD 液體冷卻器安裝
DIY 水冷支援

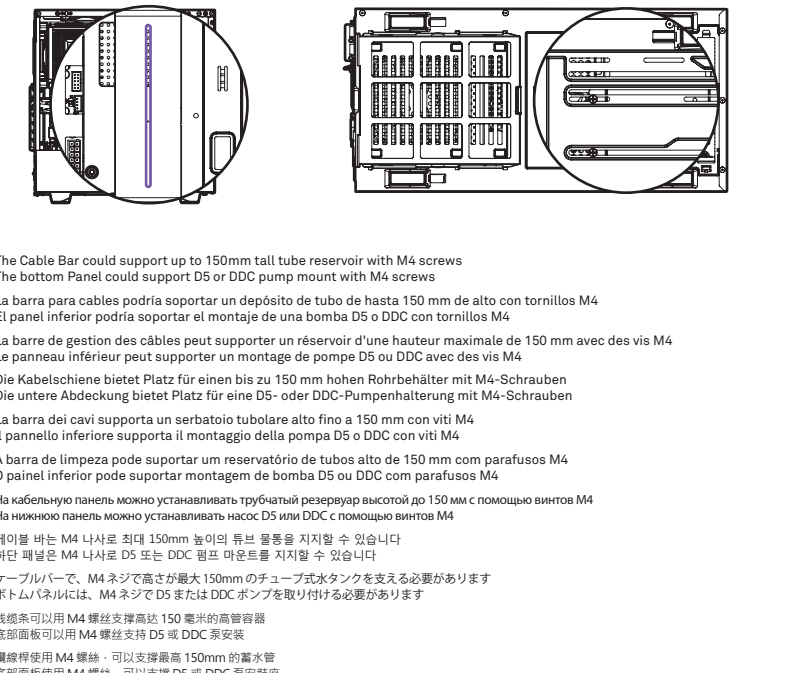

UNSCREW THE THUMB SCREW

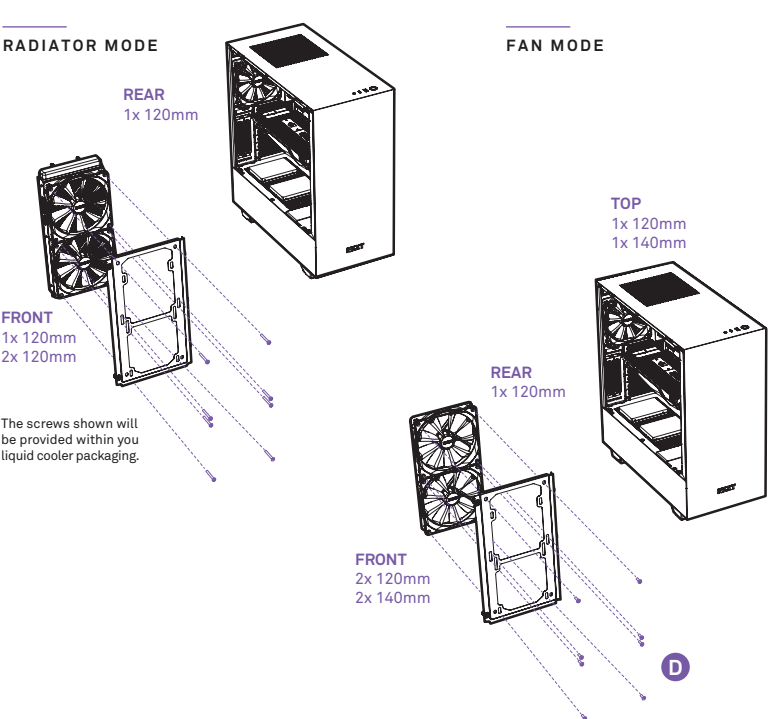

HAZARDOUS SUBSTANCES

有毒害物質及元素

设备名称：机箱 - H系列

部件名称	有害物质	铅 (Pb)	汞 (Hg)	镉 (Cd)	六价铬 (Cr ⁶⁺)	多溴联苯 (PBB)	多溴联苯醚 (PBDE)
PCBA及板上元件	○	○	○	○	○	○	○
连接器	○	○	○	○	○	○	○
线材	○	○	○	○	○	○	○
金属结构件	○	○	○	○	○	○	○
塑胶材料	○	○	○	○	○	○	○
线材	○	○	○	○	○	○	○
包装材料	○	○	○	○	○	○	○
纸袋及印刷品	○	○	○	○	○	○	○

本表格依据SJ/T 11364的限定标准。
○:表示该有害物质在该部件所有原材料中的含量均在GB/T 26572规定的限量要求下。
X:表示该有害物质至少在该部件的某一基材材料中的含量超出GB/T 26572规定的限量要求。

設備名稱：機箱 - H系列

附用物質及其化學符號	鉛 (Pb)	汞 (Hg)	鎘 (Cd)	六價鉻 (Cr ⁶⁺)	多溴聯苯 (PBB)	多溴聯苯醚 (PBDE)
PCBA及板上元件	○	○	○	○	○	○
連接器	○	○	○	○	○	○
線材	○	○	○	○	○	○
金屬結構件	○	○	○	○	○	○
塑膠結構件	○	○	○	○	○	○
線材	○	○	○	○	○	○
包裝及包装材料	○	○	○	○	○	○
紙袋及印刷品	○	○	○	○	○	○

備註： "超出 0.1 wt%"及 "超出 0.01 wt%"係指附用物質之百分比含量超出百分比含量標準。
備註： "○"係指該附用物質之百分比含量未超出百分比含量標準。
備註： "X"係指該附用物質為禁輸項目。

REGULATIONS



This personal computer case with the smart device is tested to comply with FCC standard, Australian standard and EMC EUC Directive (2014/53/EU).
This Class I personal computer case with smart device complies with Canadian ICES-003.
Ce cas d'ordinateur personnel de classe B avec dispositif intelligent est conforme à la norme NMB-003 du Canada

NZXT GLOBAL WARRANTY POLICY

New NZXT Product	Warranty Length for Parts
Computer Cases	2 Years
Temperatures Meters	2 Years
Fans	2 Years
Lighting	2 Years
Accessories	2 Years
Headset/Headphone	2 Years
Mixer	2 Years
Speakers	2 Years
K/K/A/K/M Coolers	3 Years
Motherboards	4 Years
HALVED Power Supply	5 Years
PS/AN Coolers	6 Years

Refurbished NZXT Product	Warranty Length for Parts
All NZXT Certified Refurbished Products	1 Years

Any replacement product will be covered under warranty for the remainder of the warranty period or thirty days, whichever is longer. Proof of purchase is required for warranty service.

II. WHO IS PROTECTED
The Warranty covers only NZXT products purchased by the original consumer.
III. WHAT IS AND IS NOT COVERED
Please note that our warranty is not an unconditional guarantee. If the product, in NZXT's reasonable opinion, malfunctions within the warranty period, NZXT will provide you at its sole discretion with a repaired or replacement product, either new or refurbished, with a similar function that is equal or greater in value depending on supply. Our warranty does not cover the following:
• any product or serial number/warranty sticker replacement applied without permission from NZXT;
• any damage that is not a manufacturing defect;
• damage, deterioration or malfunction resulting from: accident, abuse, misuse, neglect, fire, water, lightning, or other acts of nature, unauthorized product modification or failure to follow instructions included with the product;
• improper installation, unauthorized alterations or modifications, or repair or attempted repair by anyone not authorized by NZXT;
• shipping or transport damage (claims must be made with the carrier); and
• normal wear and tear.

NZXT does not warrant that this product will meet your requirements. It is your responsibility to determine the suitability of this product for your purpose. For NZXT Store orders, we cover two way return shipping for all exchanges and returns. For all other authorized dealers, NZXT Support does not cover return shipping and only covers one way shipping from NZXT back to the end user for exchanges. Two way expedited shipping is provided for all PSUs covered under the Less Than Three program. Indiscriminate of purchase location, provided the location is an approved NZXT reseller.

IV. EXCLUSION OF DAMAGES (DISCLAIMER)
NZXT's sole obligation and liability under this warranty is limited to the repair or replacement of a defective product with either a new or refurbished product with a similar function that is equal or greater in value at our option. NZXT shall not, in any event, be liable for any incidental or consequential damages, including but not limited to damages resulting from interruption of service and loss of data, business, or for liability in tort relating to this product or resulting from its use or possession.

V. LIMITATIONS OF IMPLIED WARRANTIES
There are no other warranties, expressed or implied, including but not limited to those of merchantability or fitness for a particular purpose. The duration of implied warranties is limited to the warranty length specified in Paragraph 1.

VI. TO OBTAIN TECHNICAL SUPPORT
If you have already referenced your product owner's manual and still need help, you may contact us by phone at +1 (800) 228-9395, by email at service@nzxt.com, or visit the NZXT Support site at <https://www.nzxt.com/customer-support>.

VII. APPLICABLE LAW AND ADDITIONAL LEGAL RIGHTS FOR CONSUMERS
This warranty gives you specific legal rights. These conditions are governed and construed in accordance with the laws of California (with exception of its conflict of law provisions), and the application of the United Nations Convention of Contracts for the International Sale of Goods is expressly excluded. The non-exclusive jurisdiction of the courts of California is agreed, which means that you may bring a claim to enforce your consumer protection rights in connection with this Global Warranty in the country which you have your habitual residence where you may have additional rights. These rights may vary.

VIII. APPLICABLE LAW AND ADDITIONAL LEGAL RIGHTS FOR CONSUMERS
If you have already referenced your product owner's manual and still need help, you may contact us by phone at +1 (800) 228-9395, by email at service@nzxt.com, or visit the NZXT Support site at <https://www.nzxt.com/customer-support>.

IX. APPLICABLE LAW AND ADDITIONAL LEGAL RIGHTS FOR CONSUMERS
This warranty gives you specific legal rights. These conditions are governed and construed in accordance with the laws of California (with exception of its conflict of law provisions), and the application of the United Nations Convention of Contracts for the International Sale of Goods is expressly excluded. The non-exclusive jurisdiction of the courts of California is agreed, which means that you may bring a claim to enforce your consumer protection rights in connection with this Global Warranty in the country which you have your habitual residence where you may have additional rights. These rights may vary.

X. NZXT.COM STORE RETURNS/EXCHANGE POLICY
Eligible products under this NZXT Warranty qualify for a full refund or exchange only with an authorized RMA number and if the item is returned to the NZXT.com Store inventory within 30 days of purchase. Returns are not allowed beyond 90 days of the purchase date. The NZXT.com Store reserves the right to deny any return or exchange. Refunds will be credited to the original method of payment. To initiate a return, simply submit a request via NZXT support site.

XI. APPLICABLE LAW AND ADDITIONAL LEGAL RIGHTS FOR CONSUMERS
This warranty gives you specific legal rights. These conditions are governed and construed in accordance with the laws of California (with exception of its conflict of law provisions), and the application of the United Nations Convention of Contracts for the International Sale of Goods is expressly excluded. The non-exclusive jurisdiction of the courts of California is agreed, which means that you may bring a claim to enforce your consumer protection rights in connection with this Global Warranty in the country which you have your habitual residence where you may have additional rights. These rights may vary.

IN THE UK:
• For NZXT products sold to customers in the UK, during the expected lifespan of your product your legal rights entitle you to the following:
> Up to 30 days: if your goods are faulty, then you can get an immediate refund.
> Up to six months: if your goods can't be repaired or replaced, then you're entitled to a full refund, in most cases.
> Up to six years: if your goods do not last a reasonable length of time you may be entitled to some money back.

• If the person seeking to rely on the guarantee is not the original consumer, the NZXT Warranty will cover the product in relation to that person provided that they are able to provide proof of the transfer of the benefits of the guarantee to the original consumer.

• The implied warranties under the Consumer Rights Act 2015 says that your goods must be as described, fit for all purposes for which such goods are usually supplied, and of satisfactory quality.

IN THE EU:
• If you are a consumer and have your habitual residence in the EU you additionally enjoy the protection afforded to you by provisions that cannot be derogated from by agreement by virtue of the law where you have your habitual residence.

IX. WARRANTY SERVICE FROM RESELLERS
In the event that a warranty service is sought, you must provide proof of purchase (store receipt or invoice) in order to receive the service and if deemed necessary, repair or replacement product.

In North America:
Within the first 60 days after purchase, please return your product (or for power supplies installed within our enclosures, just the failed power supply) to your dealer or reseller for a replacement. If the product is still within warranty and you can no longer return it to your dealer, please contact NZXT Customer Support (see above) for assistance and instructions. NZXT will not accept returns without prior approval and an RMA number.

In Europe:
Within the first year after purchase, please return your product (or for power supplies installed within our enclosures, just the failed power supply) to your dealer or reseller for a replacement. If the product is still within warranty and you can no longer return it to your dealer, please contact NZXT Customer Support (see above) for assistance and instructions. NZXT will not accept returns without prior approval.

In Australia:
Within the first two years after purchase, please return your product (or for power supplies installed within our enclosures, just the failed power supply) to your dealer or reseller for a replacement. If the product is still within warranty and you can no longer return it to your dealer, please contact NZXT Customer Support (see above) for assistance and instructions. NZXT will not accept returns without prior approval.

Outside North America, Europe, and Australasia:
If your product needs to be returned within the warranty period, please contact the retailer or distributor from whom you purchased the product.

X. NZXT.COM STORE RETURNS/EXCHANGE POLICY
Eligible products under this NZXT Warranty qualify for a full refund or exchange only with an authorized RMA number and if the item is returned to the NZXT.com Store inventory within 30 days of purchase. Returns are not allowed beyond 90 days of the purchase date. The NZXT.com Store reserves the right to deny any return or exchange. Refunds will be credited to the original method of payment. To initiate a return, simply submit a request via NZXT support site.

Support and service
If you have any questions or problems with the NZXT product you purchased, please don't hesitate to contact us using our support system. service@nzxt.com or visit the NZXT Support site at <https://www.nzxt.com/customer-support>.

Support and service
If you have any questions or problems with the NZXT product you purchased, please don't hesitate to contact us using our support system. service@nzxt.com or visit the NZXT Support site at <https://www.nzxt.com/customer-support>.

Support and service
If you have any questions or problems with the NZXT product you purchased, please don't hesitate to contact us using our support system. service@nzxt.com or visit the NZXT Support site at <https://www.nzxt.com/customer-support>.

Support and service
If you have any questions or problems with the NZXT product you purchased, please don't hesitate to contact us using our support system. service@nzxt.com or visit the NZXT Support site at <https://www.nzxt.com/customer-support>.

Support and service
If you have any questions or problems with the NZXT product you purchased, please don't hesitate to contact us using our support system. service@nzxt.com or visit the NZXT Support site at <https://www.nzxt.com/customer-support>.

Support and service
If you have any questions or problems with the NZXT product you purchased, please don't hesitate to contact us using our support system. service@nzxt.com or visit the NZXT Support site at <https://www.nzxt.com/customer-support>.

Support and service
If you have any questions or problems with the NZXT product you purchased, please don't hesitate to contact us using our support system. service@nzxt.com or visit the NZXT Support site at <https://www.nzxt.com/customer-support>.

Support and service
If you have any questions or problems with the NZXT product you purchased, please don't hesitate to contact us using our support system. service@nzxt.com or visit the NZXT Support site at <https://www.nzxt.com/customer-support>.

Support and service
If you have any questions or problems with the NZXT product you purchased, please don't hesitate to contact us using our support system. service@nzxt.com or visit the NZXT Support site at <https://www.nzxt.com/customer-support>.

Support and service
If you have any questions or problems with the NZXT product you purchased, please don't hesitate to contact us using our support system. service@nzxt.com or visit the NZXT Support site at <https://www.nzxt.com/customer-support>.

Support and service
If you have any questions or problems with the NZXT product you purchased, please don't hesitate to contact us using our support system. service@nzxt.com or visit the NZXT Support site at <https://www.nzxt.com/customer-support>.

Support and service
If you have any questions or problems with the NZXT product you purchased, please don't hesitate to contact us using our support system. service@nzxt.com or visit the NZXT Support site at <https://www.nzxt.com/customer-support>.

Support and service
If you have any questions or problems with the NZXT product you purchased, please don't hesitate to contact us using our support system. service@nzxt.com or visit the NZXT Support site at <https://www.nzxt.com/customer-support>.

Support and service
If you have any questions or problems with the NZXT product you purchased, please don't hesitate to contact us using our support system. service@nzxt.com or visit the NZXT Support site at <https://www.nzxt.com/customer-support>.

Support and service
If you have any questions or problems with the NZXT product you purchased, please don't hesitate to contact us using our support system. service@nzxt.com or visit the NZXT Support site at <https://www.nzxt.com/customer-support>.

Support and service
If you have any questions or problems with the NZXT product you purchased, please don't hesitate to contact us using our support system. service@nzxt.com or visit the NZXT Support site at <https://www.nzxt.com/customer-support>.

Support and service
If you have any questions or problems with the NZXT product you purchased, please don't hesitate to contact us using our support system. service@nzxt.com or visit the NZXT Support site at <https://www.nzxt.com/customer-support>.

Support and service
If you have any questions or problems with the NZXT product you purchased, please don't hesitate to contact us using our support system. service@nzxt.com or visit the NZXT Support site at <https://www.nzxt.com/customer-support>.

Support and service
If you have any questions or problems with the NZXT product you purchased, please don't hesitate to contact us using our support system. service@nzxt.com or visit the NZXT Support site at <https://www.nzxt.com/customer-support>.

Support and service
If you have any questions or problems with the NZXT product you purchased, please don't hesitate to contact us using our support system. service@nzxt.com or visit the NZXT Support site at <https://www.nzxt.com/customer-support>.