

# NZXT

## H6 Series

COMPACT DUAL-CHAMBER MID-TOWER AIRFLOW CASE

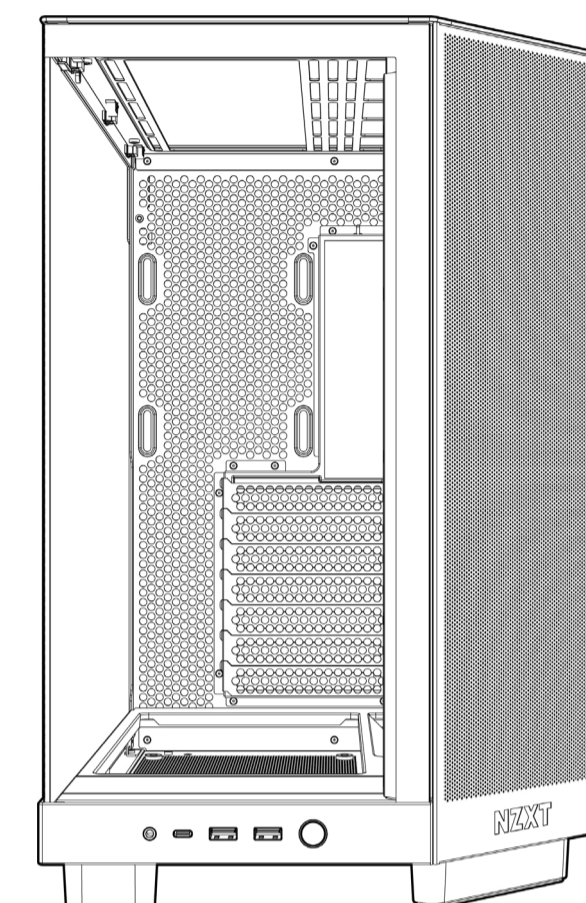

### EXPLODED VIEW

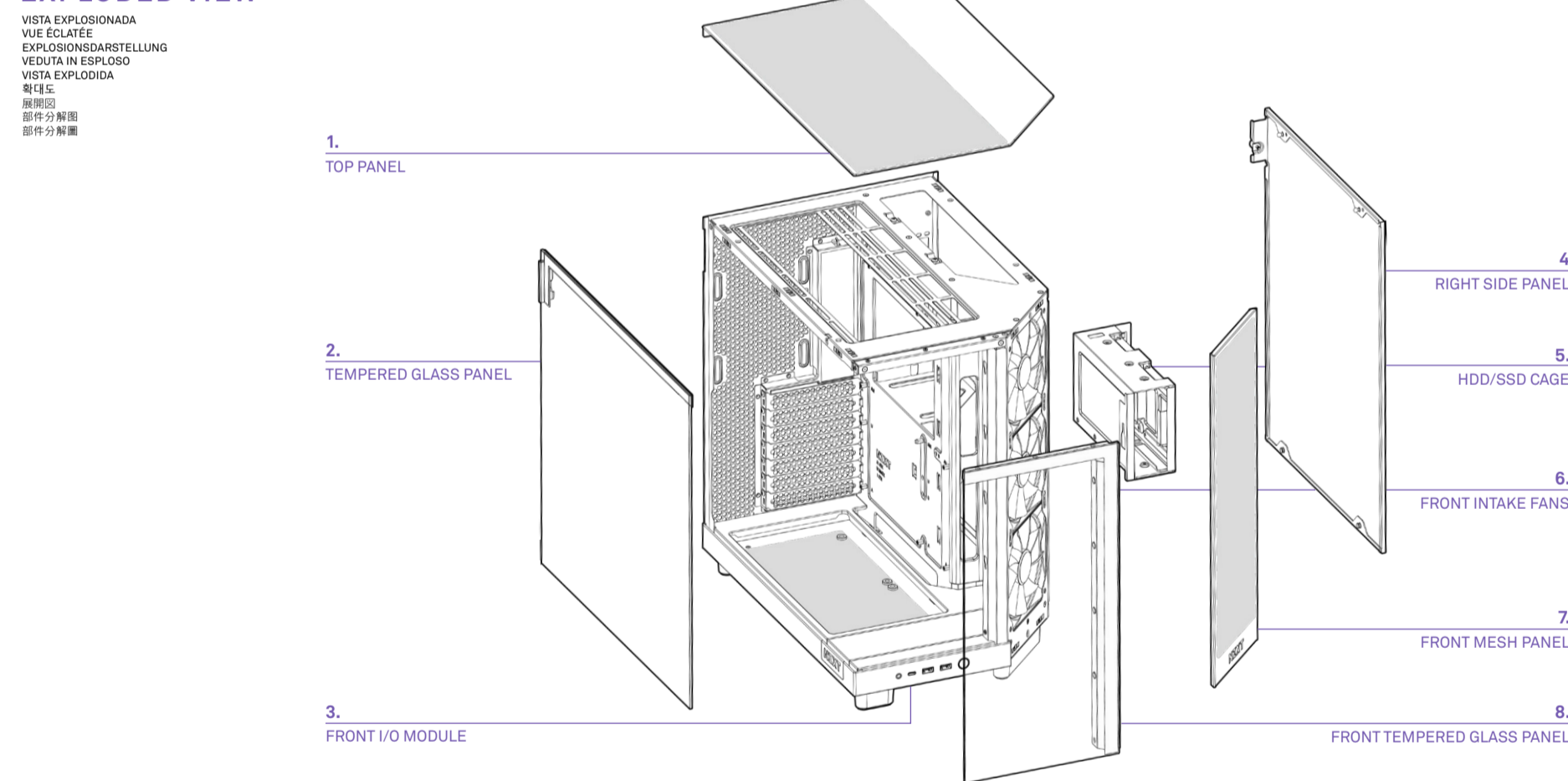

<ol style="list-style-type: none"> <li>1. Top Panel</li> <li>2. Tempered Glass Panel</li> <li>3. Front I/O Module</li> <li>4. Right Side Panel</li> <li>5. HDD/SSD Cage</li> <li>6. Front Intake Fans</li> <li>7. Front Mesh Panel</li> <li>8. Front Tempered Glass Panel</li> </ol>	<ol style="list-style-type: none"> <li>1. Abdeckung oben</li> <li>2. Linke Hartglasblende</li> <li>3. E/A-Modul an der Vorderseite</li> <li>4. Rechte Blende</li> <li>5. Festplatteneinsatz</li> <li>6. Lüfter für Lufteinlass an Vorderseite</li> <li>7. Mesh-Einsatz vorne</li> <li>8. Frontstahlblende</li> </ol>	<ol style="list-style-type: none"> <li>1. 상단 패널</li> <li>2. 좌측 강화 유리 패널</li> <li>3. 전면 I/O 모듈</li> <li>4. 우측 사이드 패널</li> <li>5. HDD/SSD 트레이</li> <li>6. 전면 흡기팬</li> <li>7. 전면 메쉬 패널</li> <li>8. 전면 강철 패널</li> </ol>	<ol style="list-style-type: none"> <li>1. 頂蓋</li> <li>2. 左側強化玻璃面板</li> <li>3. 前方 I/O 模組</li> <li>4. 右側板</li> <li>5. 硬碟/SSD 架</li> <li>6. 前方進風風扇</li> <li>7. 前網板</li> <li>8. 前部強化玻璃面板</li> </ol>
--	--	---	---

### CLEARANCES AND SPECIFICATIONS

MEASURES Y ESPECIFICACIONES  
DIMENSIONS E SPECIFICAZIONI  
DIMENSIONS E SPECIFICAZIONI

Motherboard Support	ATX, Micro-ATX and Mini-ITX	Placas base admitidas	ATX, Micro-ATX y Mini-ITX
2.5" HDD Support	2	Unidad de estado sólido de 2.5"	2
3.5" HDD Support	1	Unidad de disco duro de 3.5"	1
Expansion Slots	7	Ranuras de expansión	7
Cable Management	91mm	Administración de los cables	91mm
GPU Length Clearance	365mm	Distancia de seguridad para GPU	365mm
CPU Cooler Clearance	163mm	Distancia de la CPU	163mm
PSU Clearance	200mm	Distancia de seguridad para PSU	200mm
Top Radiator	30mm	Radiador superior	30mm

Cartes mère prises en charge	ATX, Micro-ATX, Mini-ITX	支持主板	ATX, Micro-ATX, Mini-ITX
SSD 2.5"	2	2.5" SSD 支持	2
Disques durs 3.5"	1	3.5" HDD	1
Fentes d'expansion	7	擴展槽	7
Gestion des câblages	91mm	理線空間	91mm
Espace pour le processeur	365mm	GPU 長度	365mm
Espace pour le refroidisseur	163mm	CPU 散熱器高度	163mm
Espace pour le PSU	200mm	PSU 高度	200mm
Radiateur du dessus	30mm	頂部散熱器	30mm

### ACCESSORY BOX

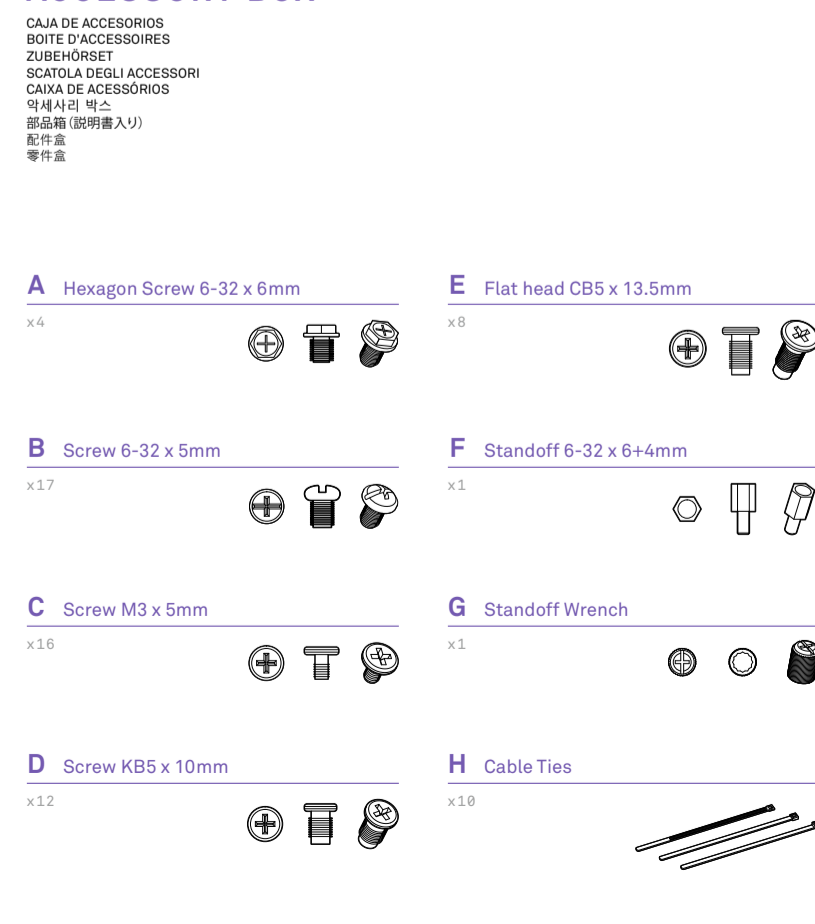

A. Hexagon Screw 6-32 x 6mm	Power supply installation	A. Vis hexagonale 6-32 x 6 mm	Instalación de la fuente de alimentación
B. Screw 6-32 x 5mm	Motherboard installation, 3.5 hard drive installation	B. Tornillo de 6-32 x 5 mm	Instalación de la placa base e instalación de la unidad de disco duro de 3.5"
C. Screw M3 x 5mm	2.5 hard drive installation	C. Tornillo M3 x 5 mm	Instalación de la unidad de disco duro de 2.5"
D. Screw K85 x 10mm	Fan installation	D. Tornillo K85 x 10 mm	Instalación del ventilador
E. Flat head CBS x 13.5mm	Fan installation	E. Tornillo CBS x 13.5 mm	Instalación del ventilador
F. Standoff 6-32 x 6.4mm	Motherboard installation	F. Entornillo 6-32 x 6.4 mm	Instalación de la placa base
G. Standoff Wrench	Motherboard installation	G. Clave para separador	Instalación de la placa base
H. Cable Ties	Cable management	H. Bracadeira para cabos	Gestão de cabos

A. Parafuso hexagonal 6-32 x 6 mm	Instalación de la fuente de alimentación	A. 六角スクリュー 6-32 x 6mm	電源装置取り付け
B. Parafuso 6-32 x 5 mm	Instalación de la placa principal, instalación de la unidad de 3.5"	B. 六角スクリュー 6-32 x 5mm	マザーボード搭載, 3.5 HDD 設置
C. Parafuso M3 x 5 mm	Instalación de la unidad de 2.5"	C. 六角 M3 x 5 mm	2.5 HDD 設置
D. Parafuso K85 x 10 mm	Instalación de la ventoinha	D. 六角 K85 x 10 mm	ファン設置
E. Parafuso CBS x 13.5 mm	Instalación de la ventoinha	E. 六角 CBS x 13.5 mm	ファン設置
F. Separador 6-32 x 6.4 mm	Instalación de la placa principal	F. 六角スクリュー 6-32 x 6.4 mm	マザーボード設置
G. Chave para separador	Instalación de la placa principal	G. 六角スクリューレンチ	マザーボード設置用
H. Bracadeira para cabos	Instalación de la placa principal	H. ケーブルタイ	ケーブル整理

### CABLE CONNECTIONS

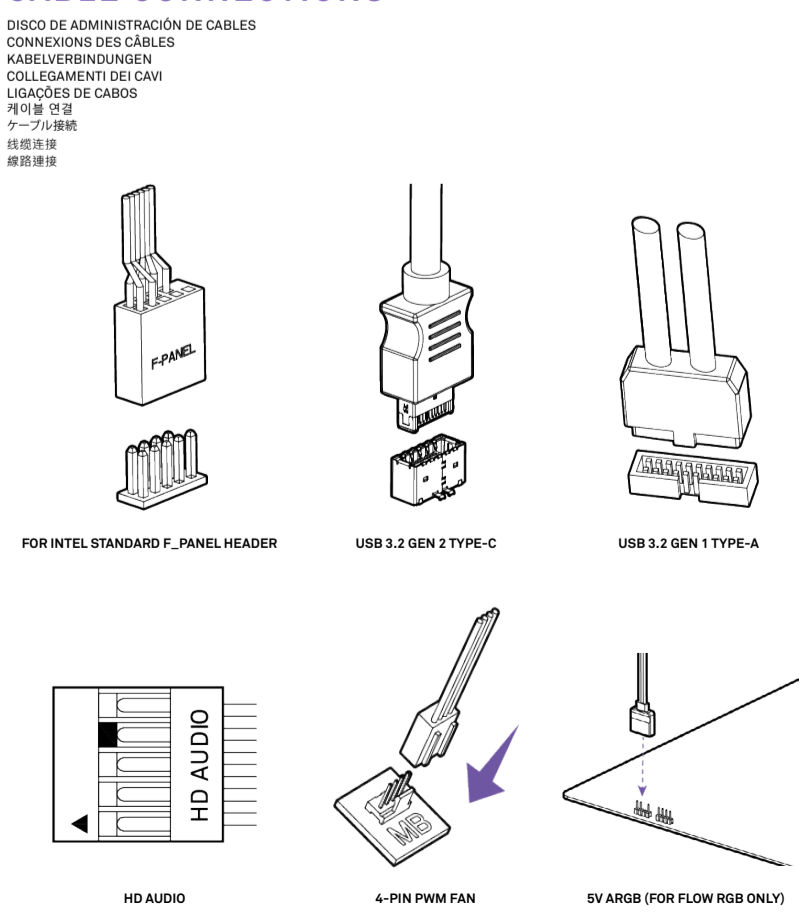

### BUTTONS AND I/O

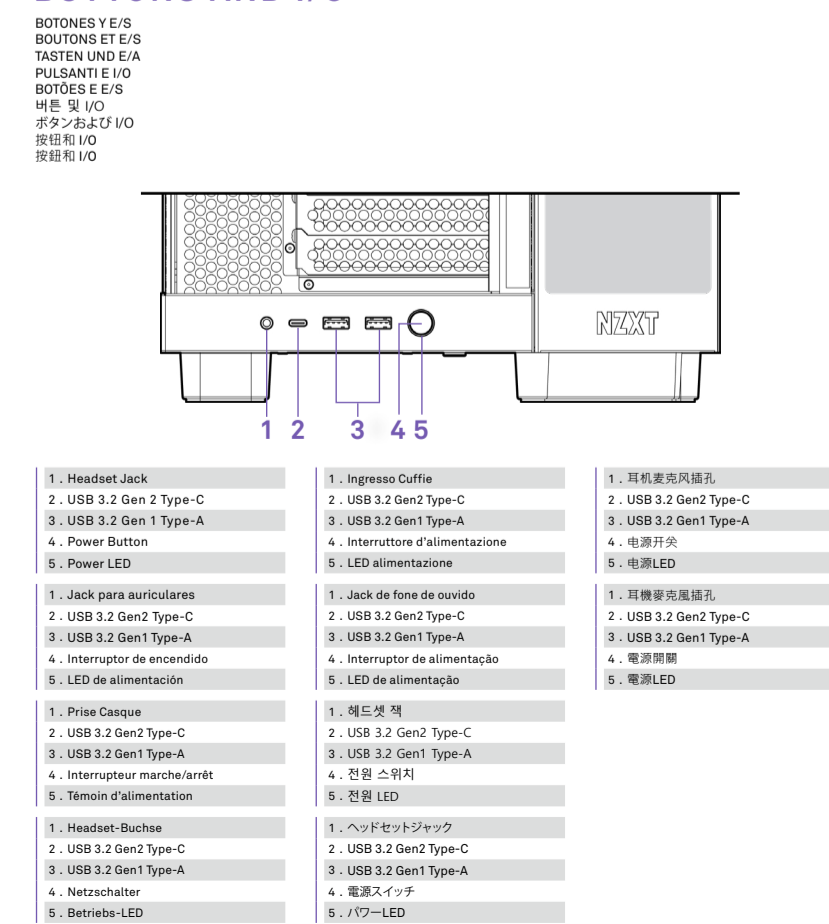

### CABLE MANAGEMENT SYSTEM

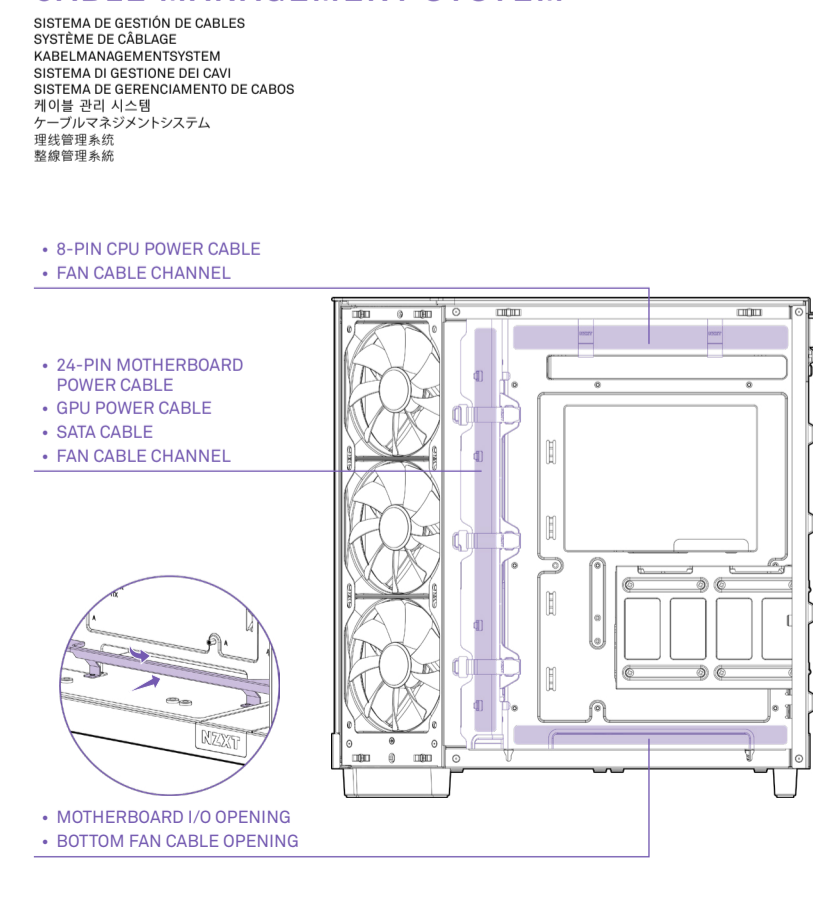

## PANEL REMOVAL

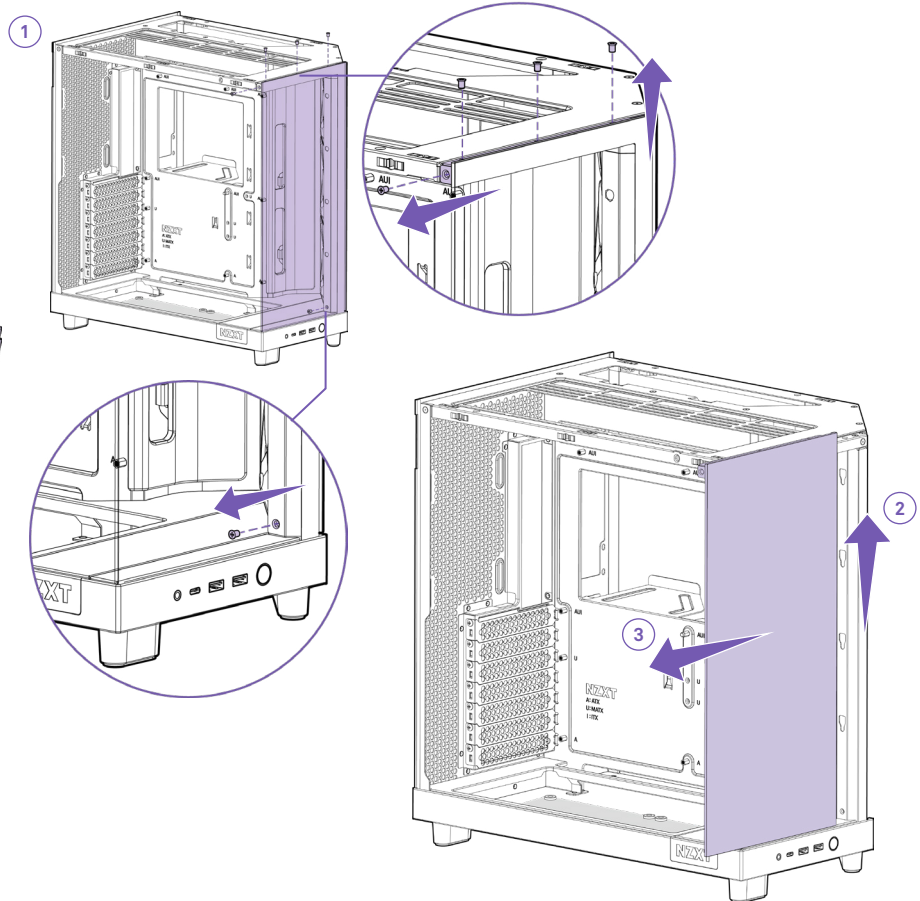
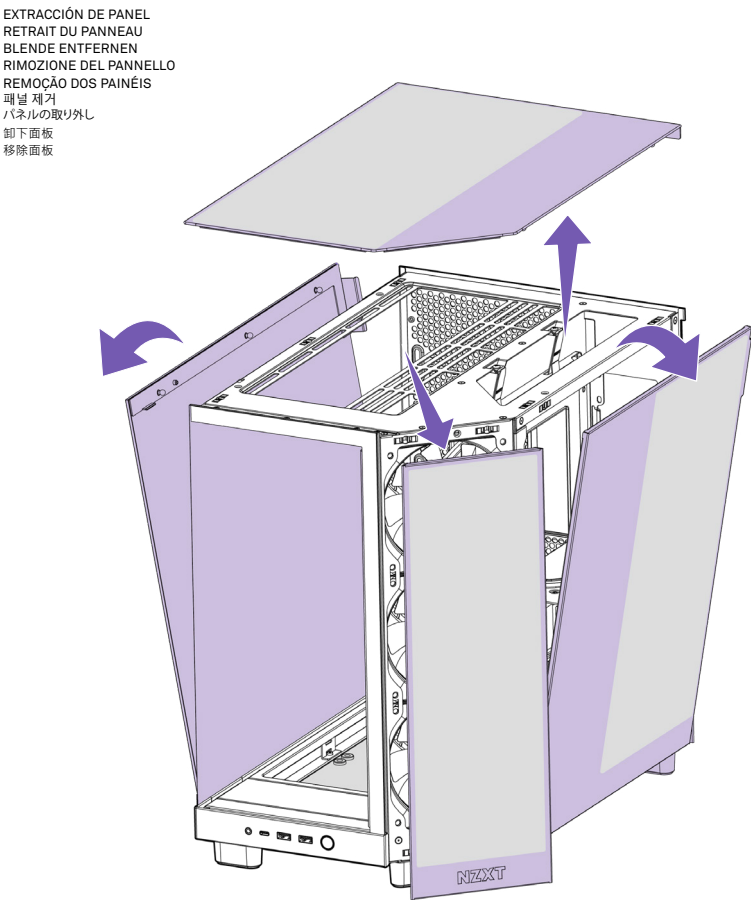

## FAN AND RADIATOR SUPPORT

COMPATIBILIDAD DE VENTILADORES Y RADIADORES  
PRISE EN CHARGE DES RADIATEURS ET VENTILATEURS  
LÜFTER- UND KÜHLER-UNTERSTÜTZUNG  
SUPPORTO VENTOLE E RADIATORE  
SUPPORTE PARA VENTONINHA E RADIADOR  
팬 및 쿨러/라디에이터 지원  
ファン/ラジエーター(冷却)サポート  
風扇和散热器支持  
風扇和散热器排架

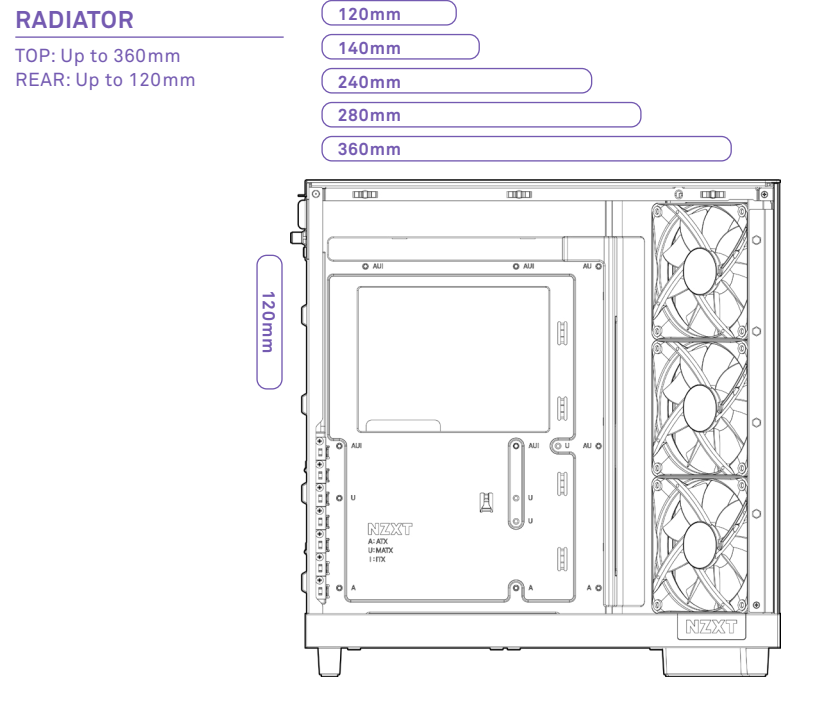
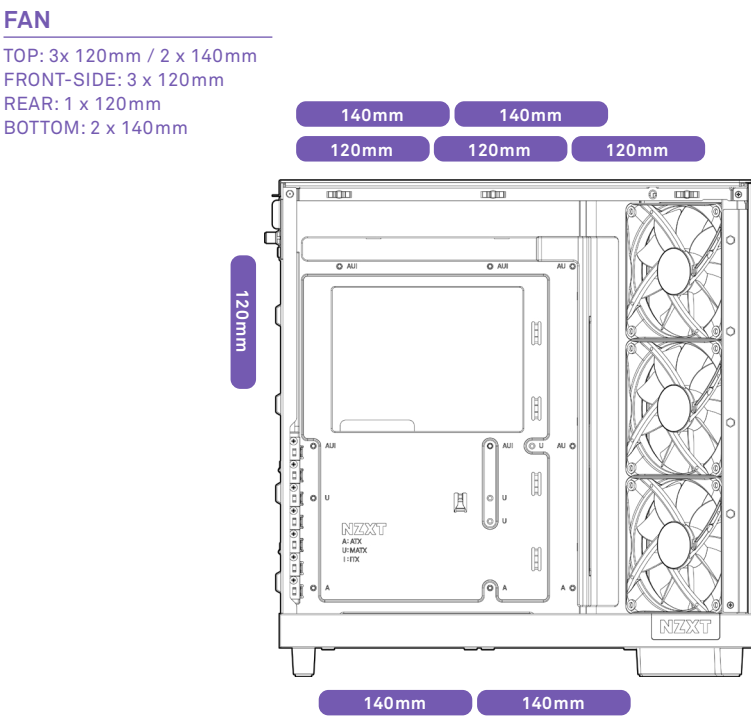

## MOTHERBOARD INSTALLATION

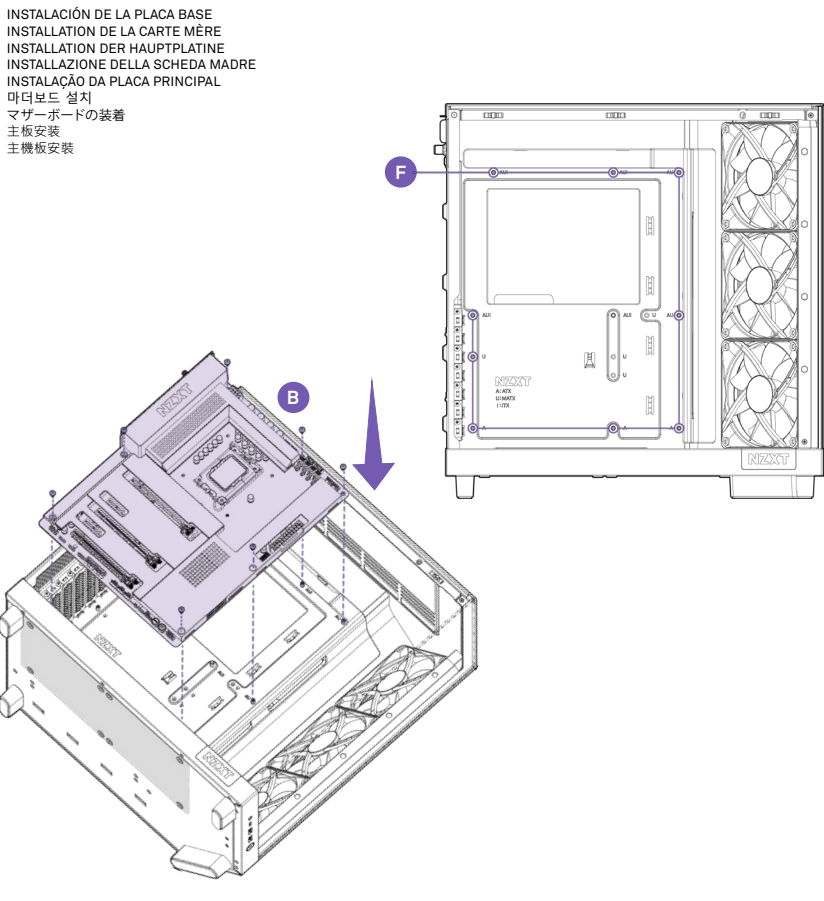

## HDD/SSD DRIVE INSTALLATION

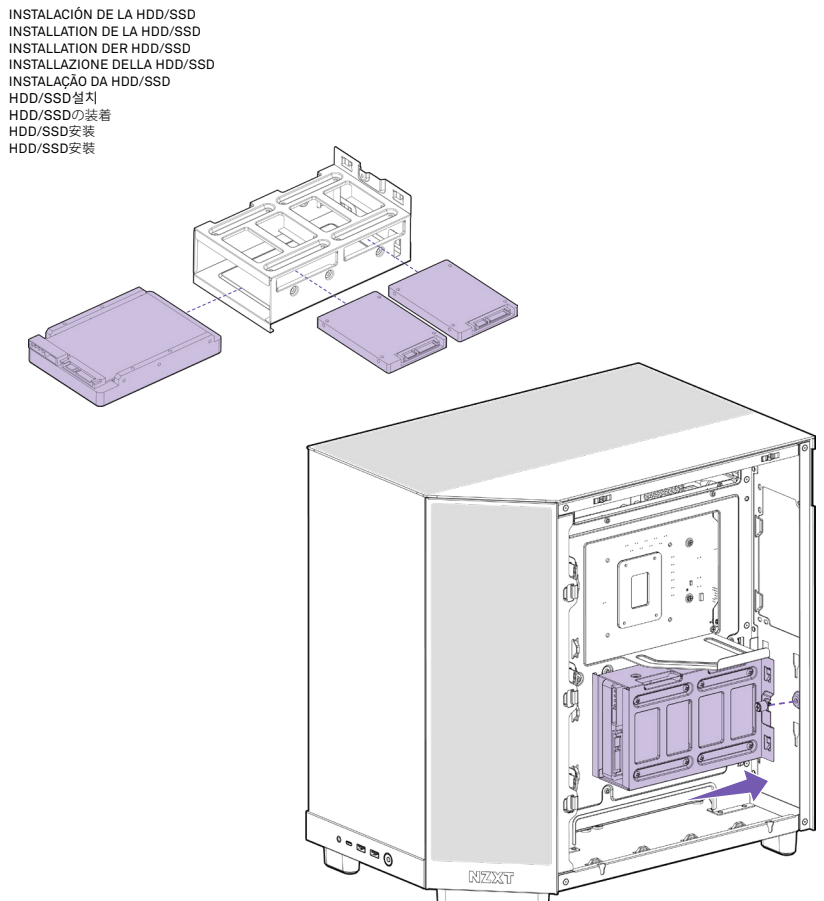

## EXPANSION CARD INSTALLATION

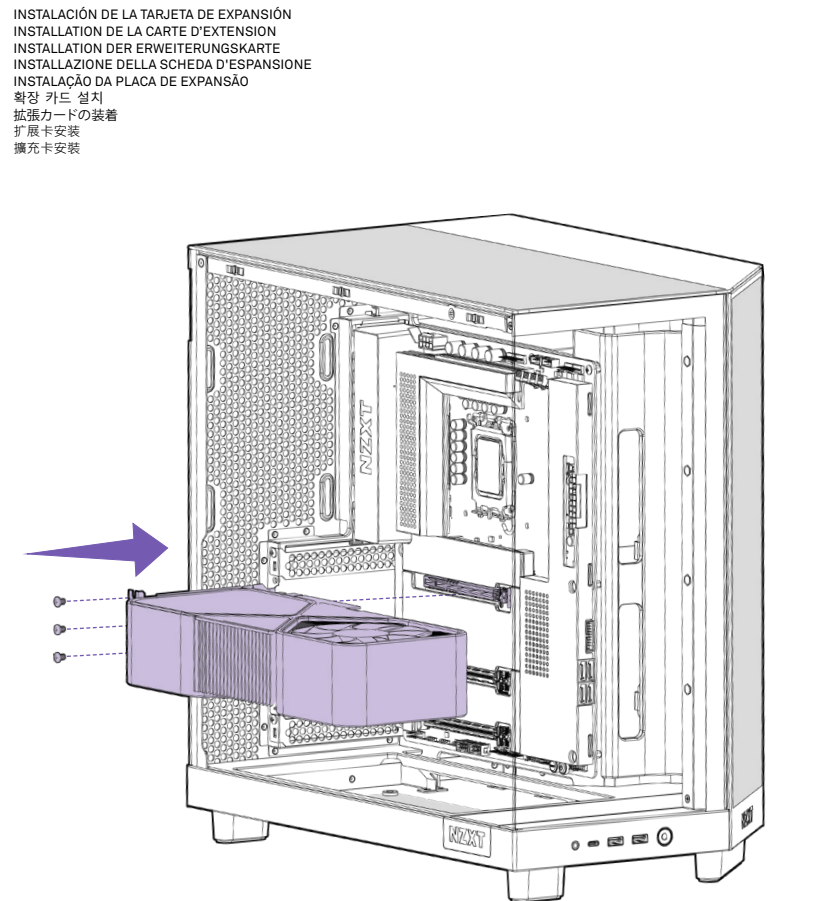

## POWER SUPPLY INSTALLATION

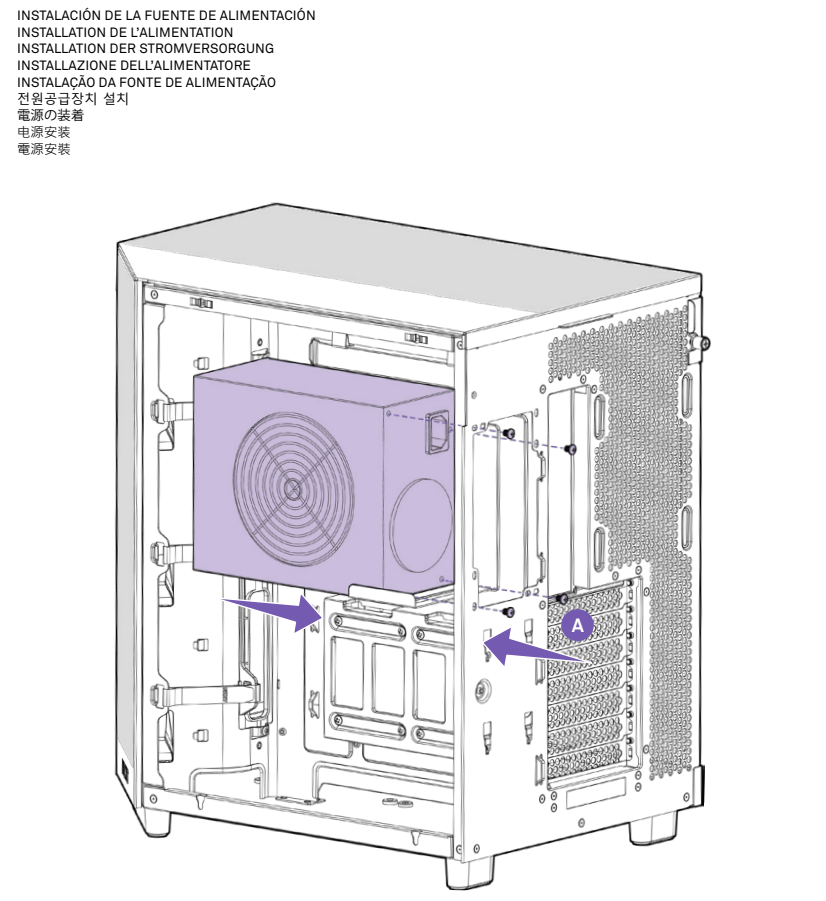

## REGULATORY STATEMENT



UKCA DECLARATION OF CONFORMITY  
The object of the declaration described above is in conformity with the relevant UK harmonisation legislation:  
• Electromagnetic Compatibility Regulations 2016  
• The Restriction of the Use of Certain Hazardous Substances in Electrical and Electronic Equipment Regulations 2012

ROHS STATEMENT  
This product is compliant to implemented RoHS (Restriction of Hazardous Substances) type regulations worldwide, including but not limited to China, India, Japan, Korea and European Union.

REACH STATEMENT  
EU REACH SVHC Disclosure on Candidate List  
REACH (Registration, Evaluation, Authorization and Restriction of Chemicals, EC 1907/2006) is the European Union's (EU) chemical substances regulatory framework. REACH requires NZXT Inc. to provide customers with sufficient information on Substances of Very High Concern (SVHC) contained in products in concentration above 0.1% weight by weight (w/w) to allow safe use of the product.

DECLARATION OF CONFORMITY  
The device complies with the requirements set out in the Council Directives relevant Union harmonisation legislation:  
• EMC Directive 2014/30/EU  
• RoHS Directive 2011/65/EU & (EU) 2015/863

DECLARATION OF CONFORMITY  
L'appareil est conforme aux exigences définies dans les directives du Conseil relatives à la législation d'harmonisation de l'Union:  
• Directive EMC 2014/30/UE  
• Directive RoHS 2011/65/UE & (UE) 2015/863

DECLARATION OF CONFORMIDAD  
El dispositivo cumple los requisitos impuestos en las directivas del Consejo relativas a la legislación de armonización de la Unión Europea:  
• Directiva sobre compatibilidad electromagnética 2014/30/UE  
• Directiva sobre sustancias peligrosas 2011/65/UE y (UE) 2015/863

DICHARAZIONE DI CONFORMITÀ  
Il dispositivo è conforme con i requisiti definiti nelle Direttive del Consiglio relative alla Norma sull'armonizzazione dell'Unione:  
• Direttiva EMC 2014/30/UE  
• Direttiva RoHS 2011/65/UE & (UE) 2015/863

KONFORMITÄTSERKLÄRUNG  
Das Gerät entspricht den Anforderungen der entsprechenden EU-Harmonisierungsrichtlinien des Rates:  
• EMV-Richtlinie 2014/30/UE  
• RoHS-Richtlinie 2011/65/UE & (EU) 2015/863

OSWADCZENIE ZGODNOŚCI  
Urządzenie jest zgodne z wymaganiami określonymi w odpowiednich unijnych Dyrektywach harmonizacyjnych Rady:  
• Dyrektywa EMC 2014/30/UE  
• Dyrektywa RoHS 2011/65/UE i (UE) 2015/863

KONFORMITÄTSEKILÄRINTÄ  
Enheten uppfyller kraven som anges i Rådets direktiv relevanta harmoniseringslagstiftning för Europeiska unionen:  
• EMC-direktiv 2014/30/UE  
• RoHS-direktiv 2011/65/UE & (EU) 2015/863

VERKLARING VAN OVEREENSTEMMING  
Het apparaat voldoet aan de vereisten van de relevante richtlijnen van de Raad met betrekking tot harmonisatielwetgeving in de Unie:  
• EMC-richtlijn 2014/30/UE  
• RoHS-richtlijn 2011/65/UE & (EU) 2015/863

To protect the global environment and as an environmentalist, NZXT must remind you that:  
Under the European Union ("EU") Directive on Waste Electrical and Electronic Equipment, Directive 2002/96/EC, prenant effet le 13 août 2005, que les produits électriques et électroniques ne peuvent être déposés dans les déchèges ou tout simple-ment mis à la poubelle. Les fabricants de ces équipements seront obligés de récupérer certains produits en fin de vie. NZXT prendra en compte cette exigence relative au retour des produits en fin de vie au sein de la communauté européenne. Par conséquent vous pouvez retourner localement ces matériels dans les points de collecte.

En tant qu'écologiste et afin de protéger l'environnement, NZXT tient à rappeler ceci:  
Au sujet de la directive européenne (UE) relative aux déchets des équipements électriques et électroniques, directive 2002/96/CE, prenant effet le 13 août 2005, que les produits électriques et électroniques ne peuvent être déposés dans les déchèges ou tout simple-ment mis à la poubelle. Les fabricants de ces équipements seront obligés de récupérer certains produits en fin de vie. NZXT prendra en compte cette exigence relative au retour des produits en fin de vie au sein de la communauté européenne. Par conséquent vous pouvez retourner localement ces matériels dans les points de collecte.

FCC, ISED Statement  
This device complies with Part 15 of the FCC Rules. Operation is subject to the following two conditions:  
(1) This device may not cause harmful interference, and (2) this device must accept any interference received, including interference that may cause undesired operation.  
CAN ICES-003(B) / NMB-003(B)

## FAN & RADIATOR INSTALLATION

INSTALACIÓN DE VENTILADORES Y RADIADORES  
INSTALLATION DES RADIATEURS ET VENTILATEURS  
LÜFTER- UND KÜHLER-INSTALLATION  
INSTALLAZIONE VENTOLE E RADIATORE  
INSTALAÇÃO PARA VENTONINHA E RADIADOR  
팬 및 쿨러/라디에이터 설치  
ファン/ラジエーター(冷却)取り付け  
風扇和散热器安裝  
風扇和散热器排架

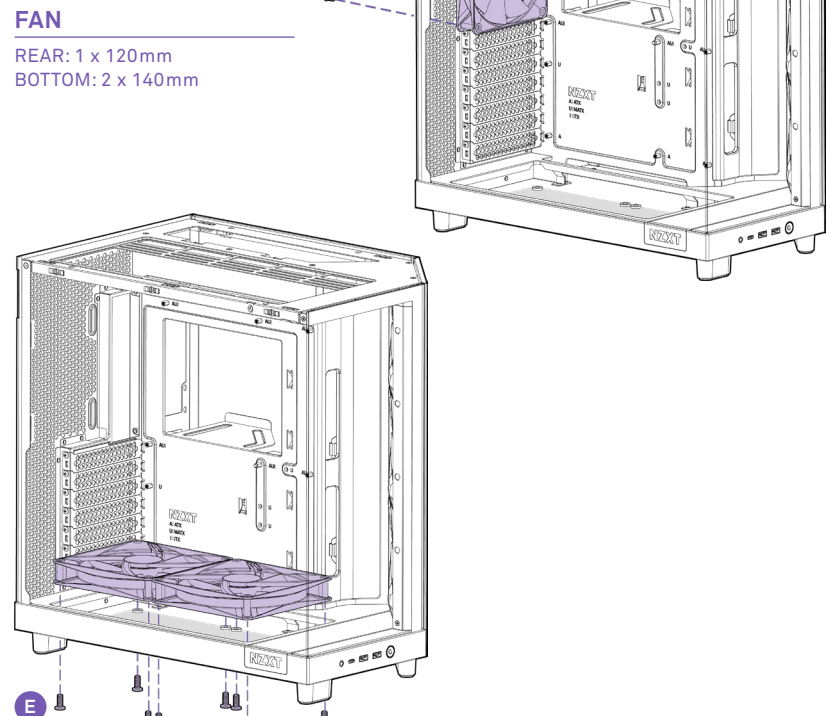
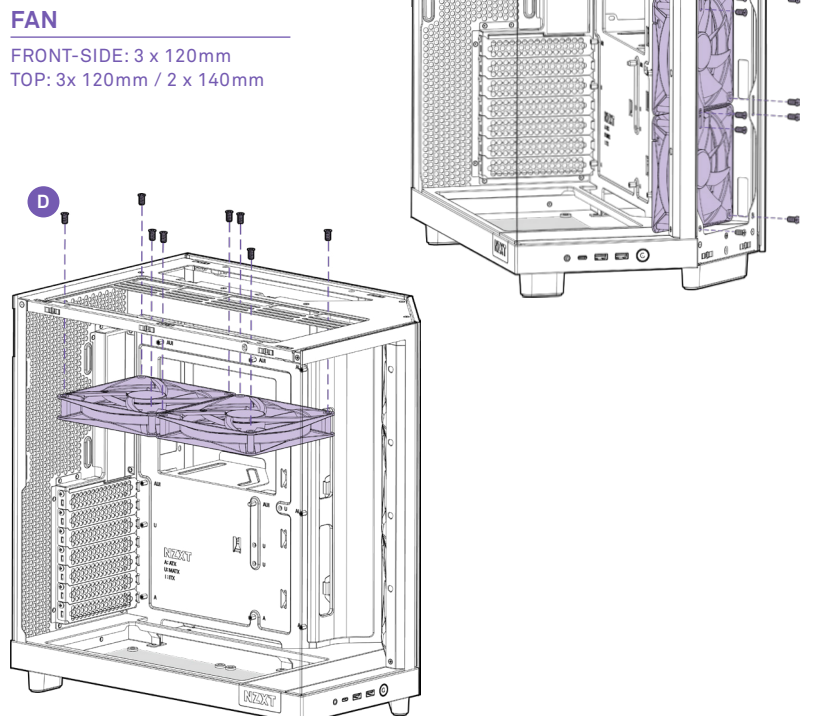
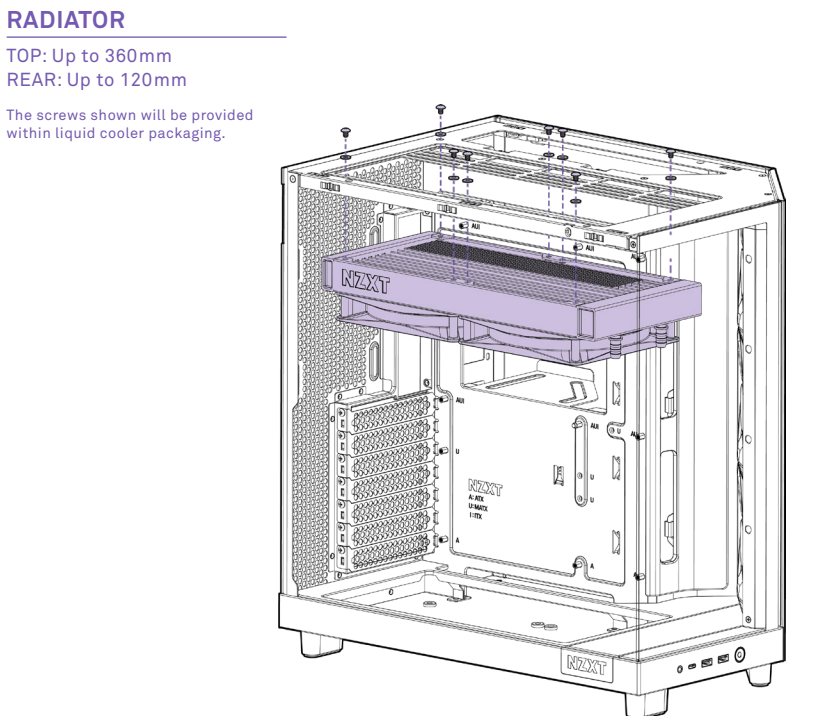

## 限用物质及元素列表 / 限用物質及元素清單

Table with columns for product name, restricted substances (Pb, Hg, Cd, Cr+, PBB, PBDE), and compliance status (Yes/No).

Table with columns for product name, restricted substances (Pb, Hg, Cd, Cr+, PBB, PBDE), and compliance status (Yes/No).

## NZXT GLOBAL WARRANTY POLICY

This NZXT Global Warranty Policy governs the sale of products by NZXT to you.

Table with columns: New NZXT Product, Warranty Length for Parts (Computer Cases, 2 Years).

Any replacement product will be covered under warranty for the remainder of the warranty period or thirty days, whichever is longer. Proof of purchase is required for warranty service.

II. WHO IS PROTECTED  
The Warranty covers only NZXT products purchased by the original consumer.

III. WHAT IS AND IS NOT COVERED  
Please note that our warranty is not an unconditional guarantee. If the product, in NZXT's reasonable opinion, malfunctions within the warranty period, NZXT will provide you at its sole discretion with a repaired or replacement product, either new or refurbished, with a similar function that is equal or greater in value depending on supply. Our warranty does not cover the following:  
• any product or serial number/warranty sticker modification applied without permission from NZXT;  
• any damage that is not a manufacturing defect;  
• damage, deterioration or malfunction resulting from accident, abuse, misuse, neglect, fire, water, lightning, or other acts of nature, unauthorized product modification or failure to follow instructions included with the product;  
• improper installation, unauthorized alterations or modifications, or repair or attempted repair by anyone not authorized by NZXT;  
• shipping or transport damage (claims must be made with the carrier);  
• normal wear and tear.

NZXT does not warrant that this product will meet your requirements. It is your responsibility to determine the suitability of this product for your purpose. For NZXT Store orders, we cover two way return shipping for all exchanges and returns. For all other authorized dealers, NZXT Support does not cover return shipping and only covers one way shipping from NZXT back to the end user for exchanges. Two way expedited shipping is provided for all PSUs covered under the Less Than Three program, indiscriminate of purchase location, provided the location is an approved NZXT reseller.

IV. EXCLUSION OF DAMAGES (DISCLAIMER)  
NZXT's sole obligation and liability under this warranty is limited to the repair or replacement of a defective product with either a new or refurbished product with a similar function that is equal or greater in value at our option. NZXT shall not, in any event, be liable for any incidental or consequential damage, including but not limited to damages resulting from interruption of service and loss of data, business, or for liability in tort relating to this product or resulting from its use or possession.

V. LIMITATIONS OF IMPLIED WARRANTIES  
There are no other warranties, expressed or implied, including but not limited to those of merchantability or fitness for a particular purpose. The duration of implied warranties is limited to the warranty length specified in Paragraph I.

VI. TO OBTAIN TECHNICAL SUPPORT  
If you have already referenced your product owner's manual and still need help, you may contact us by phone at +1 (800) 228-8395, by email at [support@nzxt.com](mailto:support@nzxt.com), or visit the NZXT Support site at [nzxt.com/customer-support](http://nzxt.com/customer-support).

VII. HOW TO RETURN A WARRANTY SERVICE FROM NZXT  
To receive a warranty service for your product when purchased directly from NZXT, you must submit a request via the NZXT Support site outlining the problem. If a technician determines the product defective or requiring testing, you will be required to provide a copy of your proof of purchase, which will enable you to submit a Return Merchandise Authorization ("RMA") request.  
Once approved, you'll receive an RMA number, upon which you will be asked to ship the defective item back to NZXT with the RMA number clearly marked or labelled on the package. NZXT recommends that appropriate measures are taken to safeguard the product from damage during shipping.

## VIII. APPLICABLE LAW AND ADDITIONAL LEGAL RIGHTS FOR CONSUMERS

This warranty gives you specific legal rights. These conditions are governed and construed in accordance with the laws of California (with exception of its conflict of law provisions), and the application of the United Nations Convention of Contracts for the International Sale of Goods is expressly excluded. The non-exclusive jurisdiction of the courts of California is agreed, which means that you may bring a claim to enforce your consumer protection rights in connection with this Global Warranty in the country which you have your habitual residence where you may have additional rights. These rights may vary.  
For original consumers who are covered by consumer protection laws or regulations in their country, state, or province of purchase or, if different, their country, state, or province of residence, the benefits conferred by this warranty are in addition to all rights and remedies conveyed by such consumer protection laws and regulations. To the extent that liability under such consumer laws can be limited, NZXT's liability is limited, and its sole option, to repair or replacement, either new or refurbished, with a similar function that is equal or greater in value depending on supply.

In the United Kingdom:  
• For NZXT products sold to customers in the UK, during the expected lifespan of your product your legal rights entitle you to the following:  
• Up to 30 days: if your goods are faulty, then you can get an immediate refund.  
• Up to six months: if your goods can't be repaired or replaced, then you're entitled to a full refund, in most cases.  
• Up to six years: if your goods do not last a reasonable length of time you may be entitled to some money back.  
• If the person seeking to rely on the guarantee is not the original consumer, the NZXT Warranty will cover the product in relation to that person provided that they are able to provide proof of the transfer of the benefit of the guarantee from the original consumer.  
• The implied warranties under the Consumer Rights Act 2015 says that your goods must be as described, fit for all purposes for which such goods are usually supplied, and of satisfactory quality.

In the EU:  
• If you are a consumer and have your habitual residence in the EU, you additionally enjoy the protection afforded to you by provisions that cannot be derogated from by agreement by virtue of the law where you have your habitual residence.

IX. WARRANTY SERVICE FROM RESSELLERS  
In the event that a warranty service is sought, you must provide proof of purchase (store receipt or invoice) in order to receive the service and if deemed necessary, repair or replacement product.

In North America:  
Within the first 60 days after purchase, please return your product (or for power supplies installed within our enclosures, just the failed power supply) to your dealer or reseller for a replacement. If the product is still within warranty and you can no longer return it to your dealer, please contact NZXT Customer Support (see above) for assistance and instructions. NZXT will not accept returns without prior approval and an RMA number.

In Europe:  
Within the first year after purchase, please return your product (or for power supplies installed within our enclosures, just the failed power supply) to your dealer or reseller for a replacement. If the product is still within warranty and you can no longer return it to your dealer, please contact NZXT Customer Support (see above) for assistance and instructions. NZXT will not accept returns without prior approval.

In Australasia:  
Within the first two years after purchase, please return your product (or for power supplies installed within our enclosures, just the failed power supply) to your dealer or reseller for a replacement. If the product is still within warranty and you can no longer return it to your dealer, please contact NZXT Customer Support (see above) for assistance and instructions. NZXT will not accept returns without prior approval.

Outside North America, Europe, and Australasia:  
If your product needs to be returned within the warranty period, please contact the retailer or distributor from whom you purchased the product.  
X. NZXT.COM STORE RETURNS/EXCHANGE POLICY  
Eligible products under this NZXT Warranty qualify for a full refund or exchange only with an authorized RMA number and if the item is returned to the NZXT.com store inventory within 30 days of purchase. Returns are not allowed beyond 30 days of the purchase date. The NZXT.com Store reserves the right to deny any return or exchange. Refunds will be credited to the original method of payment. To initiate a return, simply submit a request via NZXT support site.

## SUPPORT AND SERVICE

SUPPORT AND SERVICE  
If you have any questions or problems with the NZXT product you purchased, please don't hesitate to contact us using our support system. [support@nzxt.com](mailto:support@nzxt.com)

Please include a detailed explanation of your problem and your proof of purchase. For comments and suggestions, you can e-mail our design team. [designer@nzxt.com](mailto:designer@nzxt.com). Lastly we would like to thank you for your support by purchasing this product.  
For more information about NZXT, please visit us online. NZXT Website: [nzxt.com](http://nzxt.com)

SOPORTE Y SERVICIO  
Si tiene preguntas o problemas con el producto NZXT que usted compró, no dude en ponerse en contacto con [service@nzxt.com](mailto:service@nzxt.com) y suministrar una explicación detallada de su problema así como su prueba de compra. Puede hacer consultas sobre piezas de repuesto en [support@nzxt.com](mailto:support@nzxt.com). Para comentarios y sugerencias, escriba un mensaje de correo electrónico a nuestro equipo de diseño: [designer@nzxt.com](mailto:designer@nzxt.com). Gracias por comprar un producto NZXT. Para más información acerca de NZXT, visítanos en línea. Página web de NZXT: [nzxt.com](http://nzxt.com)

SUPPORT ET SERVICE  
Si vous avez des questions ou des problèmes avec le produit NZXT que vous avez acheté, n'hésitez pas à contacter [service@nzxt.com](mailto:service@nzxt.com) avec une description détaillée de votre problème et votre preuve d'achat. Vous pouvez aussi commander des pièces de remplacement auprès [support@nzxt.com](mailto:support@nzxt.com). Pour les commentaires et les suggestions, envoyez un e-mail à notre équipe de design. [designer@nzxt.com](mailto:designer@nzxt.com). Merci d'avoir acheté ce produit de NZXT. Pour plus d'informations sur NZXT, visitez notre site Web. Site Web de NZXT: [nzxt.com](http://nzxt.com)

KUNDENDIENST UND SERVICE  
Falls Fragen oder Probleme bezüglich Ihres NZXT-Produktes auftreten, wenden Sie sich bitte mit einer detaillierten Problembeschreibung und Ihrem Kaufbeleg an [service@nzxt.com](mailto:service@nzxt.com). Ersatzteile können Sie unter [support@nzxt.com](mailto:support@nzxt.com) anfragen. Kommentare und Anregungen senden Sie bitte per [designer@nzxt.com](mailto:designer@nzxt.com) an unser Designteam. Vielen Dank, dass Sie ein NZXT-Produkt erworben haben. Weitere Informationen über NZXT erhalten Sie im Internet. NZXT-Website: [nzxt.com](http://nzxt.com)

ASSISTENZA E SERVIZIO  
In caso di dubbi o problemi con il prodotto NZXT acquistato, non esitate a contattarci utilizzando il nostro sistema di assistenza. [support@nzxt.com](mailto:support@nzxt.com)

Inclusione una spiegazione dettagliata del problema e la prova di acquisto. Per commenti e suggerimenti, siete pregati di inviare un messaggio al nostro team di progettisti, all'indirizzo: [designer@nzxt.com](mailto:designer@nzxt.com). Infine, vogliamo ringraziarvi del supporto con l'acquisto di questo prodotto. Per altre informazioni su NZXT, visitate il nostro sito. Sito NZXT: [nzxt.com](http://nzxt.com)

ASSISTÊNCIA E MANUTENÇÃO  
Caso tenha questões ou problemas com o produto NZXT adquirido, não hesite em contactar-nos através do endereço [service@nzxt.com](mailto:service@nzxt.com) fornecendo a explicação detalhada do seu problema e a prova de compra. Poderá solicitar peças de substituição através do endereço [support@nzxt.com](mailto:support@nzxt.com). Para comentários e sugestões, contacte a nossa equipa de design através de [designer@nzxt.com](mailto:designer@nzxt.com). Obrigado por ter adquirido um produto NZXT. Para mais informações acerca da NZXT, visite-nos online. Web site da NZXT: [nzxt.com](http://nzxt.com)

지원 및 서비스  
구입한 NZXT 제품을 관하여 질문 또는 문제가 있을 경우, 당사의 지원 시스템([support@nzxt.com](mailto:support@nzxt.com))을 사용하여 문의하십시오. 문제 해결 기술은 고객 응대를 제공하십시오. 의견 또는 제안 사항이 있을 경우 당사 설계 팀에 [designer@nzxt.com](mailto:designer@nzxt.com)으로 이메일을 보내십시오. 마지막으로 이 제품을 구입하여 당사를 용감하게 주셔서 감사입니다. NZXT에 대해 자세히 알려면 온라인으로 방문하십시오. NZXT 웹사이트: [nzxt.com](http://nzxt.com)

サポートおよびサービス  
ご購入されたNZXTの製品に関するご質問または問題は、問題の詳細および購入の証明書を添えて、ご連絡先 [service@nzxt.com](mailto:service@nzxt.com)までご連絡ください。交換部品は[support@nzxt.com](mailto:support@nzxt.com)までお尋ねください。ご意見および提案は弊社設計チーム [designer@nzxt.com](mailto:designer@nzxt.com)までメールを送信してください。NZXT製品をご購入いただきましたありがとうございます。NZXTに関する詳細は、インターネット上のウェブサイトをご覧ください。NZXTウェブサイト: [nzxt.com](http://nzxt.com)

支援和服務  
如有任何疑問或者在在使用 NZXT 產品的過程中遇到任何問題, 歡迎聯絡 [service@nzxt.com](mailto:service@nzxt.com), 取銷詳情請提供於問題的詳細描述及購買凭证, 您可向 [support@nzxt.com](mailto:support@nzxt.com) 查詢更換零件, 如有任何意見或建議, 歡迎致我們的設計團隊 [designer@nzxt.com](mailto:designer@nzxt.com). 最後, 感謝您購買 NZXT 產品. 有關 NZXT 的更多信息, 請訪問我們的網站 - NZXT 網站: [nzxt.com](http://nzxt.com)

支援和服務  
如果在用 NZXT 產品的過程中有遇到任何問題或疑問, 歡迎聯絡 [service@nzxt.com](mailto:service@nzxt.com), 並請提供問題的詳細描述及購買證明, 您可向 [support@nzxt.com](mailto:support@nzxt.com) 查詢更換零件, 如有任何意見或建議, 歡迎來信與設計團隊聯繫 [designer@nzxt.com](mailto:designer@nzxt.com). 最後, 感謝您購買 NZXT 產品. 有關 NZXT 的更多信息, 請訪問我們的網站 - NZXT 網站: [nzxt.com](http://nzxt.com)

支援和服務  
Si tiene preguntas o problemas con el producto NZXT que usted compró, no dude en ponerse en contacto con [service@nzxt.com](mailto:service@nzxt.com) y suministrar una explicación detallada de su problema así como su prueba de compra. Puede hacer consultas sobre piezas de repuesto en [support@nzxt.com](mailto:support@nzxt.com). Para comentarios y sugerencias, escriba un mensaje de correo electrónico a nuestro equipo de diseño: [designer@nzxt.com](mailto:designer@nzxt.com). Gracias por comprar un producto NZXT. Para más información acerca de NZXT, visítanos en línea. Página web de NZXT: [nzxt.com](http://nzxt.com)

支援和服務  
Si vous avez des questions ou des problèmes avec le produit NZXT que vous avez acheté, n'hésitez pas à contacter [service@nzxt.com](mailto:service@nzxt.com) avec une description détaillée de votre problème et votre preuve d'achat. Vous pouvez aussi commander des pièces de remplacement auprès [support@nzxt.com](mailto:support@nzxt.com). Pour les commentaires et les suggestions, envoyez un e-mail à notre équipe de design. [designer@nzxt.com](mailto:designer@nzxt.com). Merci d'avoir acheté ce produit de NZXT. Pour plus d'informations sur NZXT, visitez notre site Web. Site Web de NZXT: [nzxt.com](http://nzxt.com)

支援和服務  
Falls Fragen oder Probleme bezüglich Ihres NZXT-Produktes auftreten, wenden Sie sich bitte mit einer detaillierten Problembeschreibung und Ihrem Kaufbeleg an [service@nzxt.com](mailto:service@nzxt.com). Ersatzteile können Sie unter [support@nzxt.com](mailto:support@nzxt.com) anfragen. Kommentare und Anregungen senden Sie bitte per [designer@nzxt.com](mailto:designer@nzxt.com) an unser Designteam. Vielen Dank, dass Sie ein NZXT-Produkt erworben haben. Weitere Informationen über NZXT erhalten Sie im Internet. NZXT-Website: [nzxt.com](http://nzxt.com)

支援和服務  
In caso di dubbi o problemi con il prodotto NZXT acquistato, non esitate a contattarci utilizzando il nostro sistema di assistenza. [support@nzxt.com](mailto:support@nzxt.com)

支援和服務  
Caso tenha questões ou problemas com o produto NZXT adquirido, não hesite em contactar-nos através do endereço [service@nzxt.com](mailto:service@nzxt.com) fornecendo a explicação detalhada do seu problema e a prova de compra. Poderá solicitar peças de substituição através do endereço [support@nzxt.com](mailto:support@nzxt.com). Para comentários e sugestões, contacte a nossa equipa de design através de [designer@nzxt.com](mailto:designer@nzxt.com). Obrigado por ter adquirido um produto NZXT. Para mais informações acerca da NZXT, visite-nos online. Web site da NZXT: [nzxt.com](http://nzxt.com)

支援和服務  
구입한 NZXT 제품을 관하여 질문 또는 문제가 있을 경우, 당사의 지원 시스템([support@nzxt.com](mailto:support@nzxt.com))을 사용하여 문의하십시오. 문제 해결 기술은 고객 응대를 제공하십시오. 의견 또는 제안 사항이 있을 경우 당사 설계 팀에 [designer@nzxt.com](mailto:designer@nzxt.com)으로 이메일을 보내십시오. 마지막으로 이 제품을 구입하여 당사를 용감하게 주셔서 감사입니다. NZXT에 대해 자세히 알려면 온라인으로 방문하십시오. NZXT 웹사이트: [nzxt.com](http://nzxt.com)

NZXT, Inc. | 15736 E. Valley Blvd, City of Industry, CA 91744, USA  
X. NZXT.COM STORE RETURNS/EXCHANGE POLICY  
Eligible products under this NZXT Warranty qualify for a full refund or exchange only with an authorized RMA number and if the item is returned to the NZXT.com store inventory within 30 days of purchase. Returns are not allowed beyond 30 days of the purchase date. The NZXT.com Store reserves the right to deny any return or exchange. Refunds will be credited to the original method of payment. To initiate a return, simply submit a request via NZXT support site.

