



Questo manuale d'istruzione è fornito da trovaprezzi.it. Scopri tutte le offerte per [Phanteks Evolv X2 Nero](#) o cerca il tuo prodotto tra le [migliori offerte di Case e Alimentatori](#)

# EVOLV X<sup>2</sup>

INSTALLATION GUIDE | INSTALLATIONSANLEITUNG | GUIDE  
D'INSTALLATION | GUÍA DE INSTALACIÓN | 安装指南

**PHANTEKS**

v1.2



# PHANTEKS

For more information and product specifications, visit [www.phanteks.com](http://www.phanteks.com)

Weitere Informationen und Produktspezifikationen finden Sie unter [www.phanteks.com](http://www.phanteks.com)

Pour plus d'informations et les spécifications du produit, visitez [www.phanteks.com](http://www.phanteks.com)

Para obtener más información y especificaciones del producto, visite [www.phanteks.com](http://www.phanteks.com)

欲了解更多信息和产品规格, 请访问 [www.phanteks.com](http://www.phanteks.com)

This manual is for the following models | Dieses Handbuch gilt für die folgenden Modelle | Ce manuel concerne les modèles suivants | Este manual es para los siguientes modelos | 此手册适用于以下型号

| Model                    | Configuration | UPC Code     |
|--------------------------|---------------|--------------|
| <b>PH-ES524XTG_DBK01</b> | Brushed Black | 886523303688 |
| <b>PH-ES524XTG_DMW01</b> | Silver White  | 886523303695 |

## LEGEND

Legende | Légende | Leyenda | 说明

 Remove | Entfernen | Retirer | Eliminar | 移除

 Install | Installieren | Installer | Instalar | 安装

 Loosen | Lösen | Desserrer | Aflojar | 拧松

**EN** Phanteks will not take responsibility for any damages incurred due to incorrect installation or usage of this product.

**DE** Phanteks übernimmt keine Verantwortung für Schäden, die durch eine falsche Installation oder Verwendung dieses Produkts entstehen.

**FR** Phanteks décline toute responsabilité en cas de dommages résultant d'une installation ou d'une utilisation incorrecte de ce produit.

**ES** Phanteks no se responsabilizará de los daños ocasionados por la instalación o el uso incorrectos de este producto.

**CN** Phanteks 不会对安装中失误造成的任何损失负责，请仔细阅读本手册。

# SAFETY INFORMATION

Sicherheitsinformation | Information de Sécurité | Información de Seguridad | 安全信息

## In order to achieve maximum safety, we suggest that you adopt the following guidelines:

1. Place the product on a clean and stable surface that allows adequate air ventilation.
2. Don't use or place the product and any of its components near water, moisture, or other wet surfaces; or place the product near any heat, open flame, or other hot surfaces such as radiators, stoves, fireplaces, and candles.
3. Use caution when operating the desktop PC to avoid electrical shock or damage, such as unplugging the power supply during thunderstorms, ensuring that your hands are dry before using (and handling) the desktop PC, keeping it away from any source of liquid and/or heat source, and using all other reasonable precautions needed under the circumstances.
4. When connecting external devices to your desktop PC, carefully plan how the wires will be placed. Protect any connected cables from being trod on or pinched, particularly at plugs, convenience receptacles, or the point where they exit from.
5. Take extra caution when handling/removing/reattaching glass components. Once removed, place the glass component on a stable surface first before proceeding.
6. When unplugging any connected devices and/or cables, always pull the cable or device's plug or connector. Don't forcefully tug on its cord.
7. Don't place any heavy items on top of the product.
8. Make sure that the desktop PC is off, unplugged from the outlet, and that all connected devices are powered off and unplugged (if any) before installing or uninstalling any internal component to and/or from the desktop PC or product.

## INTERNATIONAL

### RMA & Technical Support

Internationaler RMA und technischer Support | RMA international et support technique | RMA internacional y soporte técnico | 国际 RMA 和技术支持

E-mail  
support@phanteks.com

## AMERICAS

### RMA & Technical Support

Internationaler RMA und technischer Support | RMA international et support technique | RMA internacional y soporte técnico | 国际 RMA 和技术支持

Hours  
Monday - Friday  
09:00 - 05:00 PST

Phone Number  
+1 (909) 598 2115

E-mail  
support@phanteksusa.com

# EVOLV X<sup>2</sup>



FR

Cet appareil se recycle

REPRISE À LA LIVRAISON



À DÉPOSER EN MAGASIN



À DÉPOSER EN DÉCHÈTERIE



Points de collecte sur [www.quefairede mesdechets.fr](http://www.quefairede mesdechets.fr)  
Privilégiez la réparation ou le don de votre appareil !

### NOTE ON DISPOSAL



The **WEEE** symbol indicates that this product must not be disposed of with normal household waste. Through the correct disposal of this product, you will help protect the environment. For more information on the disposal of this product, please contact your local municipality, your waste disposal service or the shop where you purchased the product.

Phanteks Group Inc.  
11F., No. 150, Jian 1st Rd.,  
Zhonghe Dist.,  
New Taipei City 235

Importer EU  
Axpertec Int. B.V. (EU)  
Sydneystraat 33  
3047 BP Rotterdam  
The Netherlands

Importer US  
Axpertec Inc. (US)  
20405 E Walnut Dr. N  
City of Industry, CA 91789  
USA

|    |   |
|----|---|
| EN | For the latest information on the product, manual, service and warranty please visit <a href="http://www.phanteks.com">www.phanteks.com</a>                   |
| DE | Die neuesten Informationen zu Produkt, Handbuch, Service und Garantie finden Sie unter <a href="http://www.phanteks.com">www.phanteks.com</a>                 |
| FR | Pour les dernières informations sur le produit, le manuel, le service et la garantie, veuillez visiter <a href="http://www.phanteks.com">www.phanteks.com</a> |
| ES | Para obtener la información más reciente sobre el producto, manual, servicio y garantía, visite <a href="http://www.phanteks.com">www.phanteks.com</a>        |
| CN | 有关产品、手册、服务和保修的最新信息，请访问 <a href="http://www.phanteks.com">www.phanteks.com</a>   |

## GENERAL SPECIFICATIONS

Allgemeine Spezifikation | Spécifications générales | Especificaciones generales | 一般规格

- 06 **Specifications** | Spezifikationen | Caractéristiques | Especificaciones | 规格
- 07 **Scope of Delivery** | Lieferumfang | Contenu de la livraison | Alcance de la entrega | 包装清单
- 08 **Dimensions** | Maße | Dimensions | Dimensiones | 尺寸
- 09 **I/O Layout** | E/A-Layout | Disposition des E/S | Disposición de E/S | 输入/输出布局

## BUILD YOUR SETUP

Erstellen Sie Ihr Setup | Construisez votre configuration | Construya su configuración | 开始安装

- 10 **Remove External Panels** | Entfernen Sie externe Panels | Supprimer les panneaux externes | Quitar paneles externos | 拆除外部面板
- 12 **Install Mainboard** | Mainboard installieren | Installer la carte mère | Instalar la placa base | 安装主板
- 13 **Install PCIe Hardware** | PCIe-Hardware installieren | Installer le matériel PCIe | Instalar hardware PCIe | 安装 PCIe 硬件
- 14 **Install Power Supply** | Netzteil installieren | Installer l'alimentation | Instalar fuente de alimentación | 安装电源
- 15 **Radiator & Fans Support** | Lüfter- und Kühlerunterstützung | Support de ventilateur et de radiateur | Soporte para ventiladores y radiadores | 风扇和散热器支持
- 16 **Install Radiator & Fans** | Installieren Sie Kühler und Lüfter | Installer un radiateur et des ventilateurs | Instalar radiadores y ventiladores | 安装散热器和风扇
- 20 **Install Storage** | Speicher installieren | Installer le stockage | Instalar almacenamiento | 安装存储
- 28 **Cable Routing** | Kabelführung | Le routage des câbles | Tendido de cables | 电缆布线
- 22 **Installing GPU Bracket** | GPU-Halterung installieren | Installation du support GPU | Instalación del soporte de GPU | 安装GPU支架
- 23 **Dust Filters** | Staubfilter | Filtres à poussière | Filtros de polvo | 除尘过滤器

## CASE SPECIFICATIONS

|  |  |
|--|--|
| <b>Dimension</b><br>Depth x Width x Height | 454 x 228 x 588 mm   |
| <b>Form Factor</b>                         | Mid-tower chassis  |
| <b>Materials</b>                           | Steel chassis, Tempered glass  |
| <b>Mainboard Support</b>                   | E-ATX*, ATX, mATX, Mini-ITX<br><small>*Up to 280mm width</small>                                     |
| <b>Rear-Connect Mainboard Support</b>      | Yes, ATX   |
| <b>Front I/O</b>                           | 2x USB 3.0<br>1x USB-C 3.2 Gen2x2<br>1x Microphone   Headphone combo<br>Power button<br>Reset button |

## PCI SLOTS & DRIVE BAYS

|                             |   |
|-----------------------------|---|
| <b>PCI Slots</b>            | 8x  |
| <b>Internal 2.5"</b>        | 5x (3x if both HDD slots are used in the bracket)                 |
| <b>Internal 3.5"</b>        | 2x (1x if SSD slots are used in the bracket)                      |
| <b>Vertical GPU Support</b> | Yes, with optional bracket<br>PH-VGPUKT4.0_03R or PH-PGPUKT4.0_01 |

## FAN 120

|               |    |
|---------------|----|
| <b>Top</b>    | 3x |
| <b>Bottom</b> | 3x |
| <b>Rear</b>   | 1x |

## RADIATOR 120

|               |           |
|---------------|-----------|
| <b>Top</b>    | up to 360 |
| <b>Bottom</b> | -         |
| <b>Rear</b>   | -         |

## CLEARANCE

|                                       |  |
|---------------------------------------|--|
| <b>CPU Cooler</b><br>Height           | 170 mm   6.69 in                           |
| <b>GPU</b><br>Length                  | 380 mm   14.96 in                          |
| <b>GPU</b><br>Width                   | 175 mm   6.88 in                           |
| <b>Power Supply</b><br>Length         | 250 mm   9.84 in                           |
| <b>Top Radiator</b><br>Length x Width | 415 x 130 x 32 mm   16.33 x 5.11 x 1.25 in |

## SCOPE OF DELIVERY



**Evolv X2**  
1x

## ACCESSORY BOX



**Microfiber Cloth**  
1x



**D-RGB Mainboard Adapter**  
80mm  
1x



**Ziptie**  
6x

## ASSORTMENT BOX



**SSD + Mainboard Screw**  
30x



**Mainboard Stand-off**  
1x



**Power Supply Screw**  
4x



**Stand-off Removal Tool**  
1x



**HDD Screw**  
8x



**Premium Vertical GPU Bracket Screw**  
3x

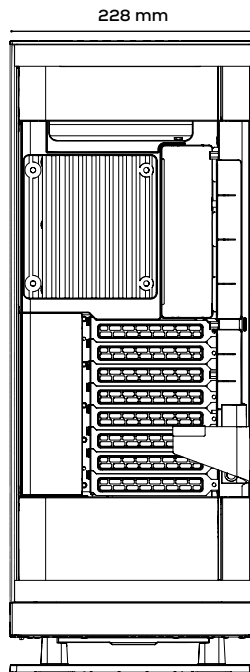
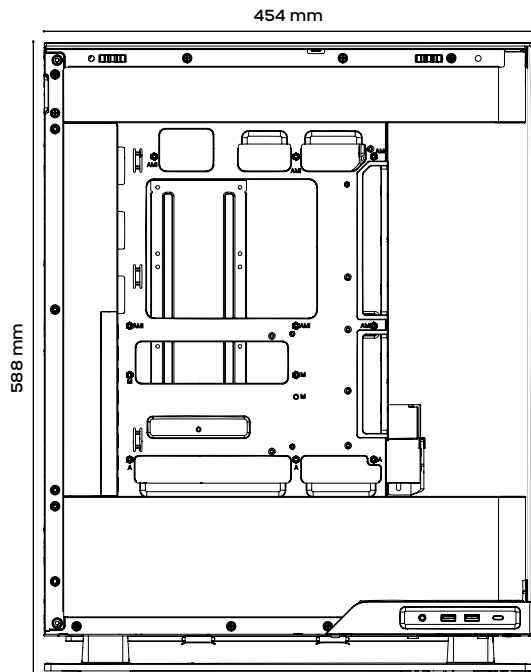

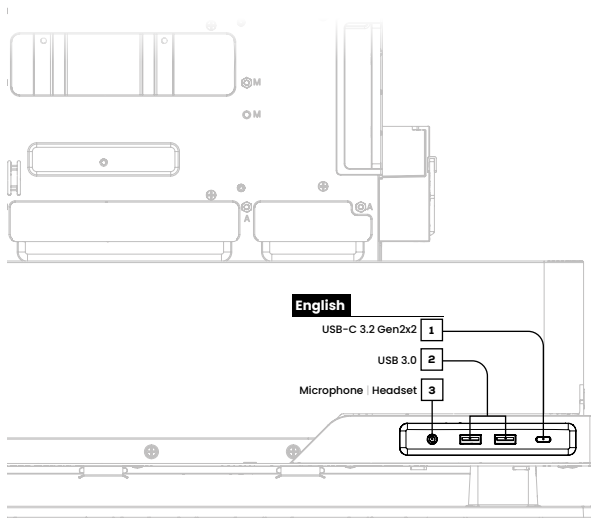

**English**

- USB-C 3.2 Gen2x2 1
- USB 3.0 2
- Microphone | Headset 3

**Deutsch**

- 1 USB-C 3.2 Gen2x2
- 2 USB 3.0
- 3 Mikrofon | Headset

**Français**

- 1 USB-C 3.2 Gen2x2
- 2 USB 3.0
- 3 Micro | Casque

**Española**

- 1 USB-C 3.2 Gen2x2
- 2 USB 3.0
- 3 Micrófono | Auricular est

**中文**

- 1 USB-C 3.2 Gen2x2
- 2 USB 3.0
- 3 麦克风 | 耳机

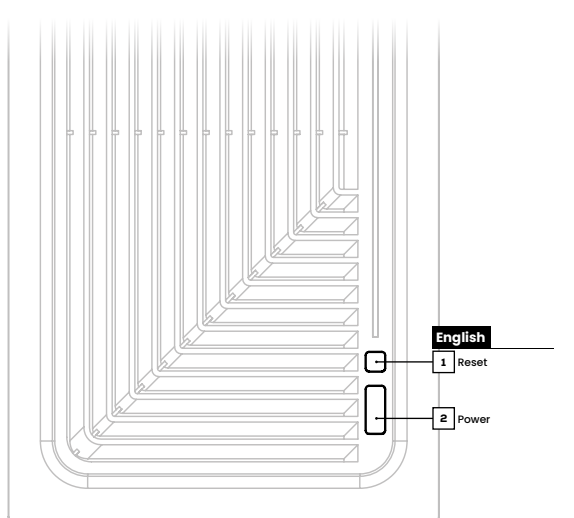

**English**

- 1 Reset
- 2 Power

**Deutsch**

- 1 Rücksetzen
- 2 Leistung

**Français**

- 1 Réinitialiser
- 2 Pouvoir

**Española**

- 1 Reiniciar
- 2 Fuerza

**中文**

- 1 重置
- 2 电源

# REMOVING EXTERNAL PANELS

Entfernen externer Bedienfelder | Retrait des panneaux externes | Quitar los paneles externos | 拆除外部面板

# EVOLV X<sup>2</sup>

## 01 REMOVE TOP PANEL

Obere Abdeckung entfernen | Retirer le panneau supérieur | Quitar el panel superior | 移除顶部面板

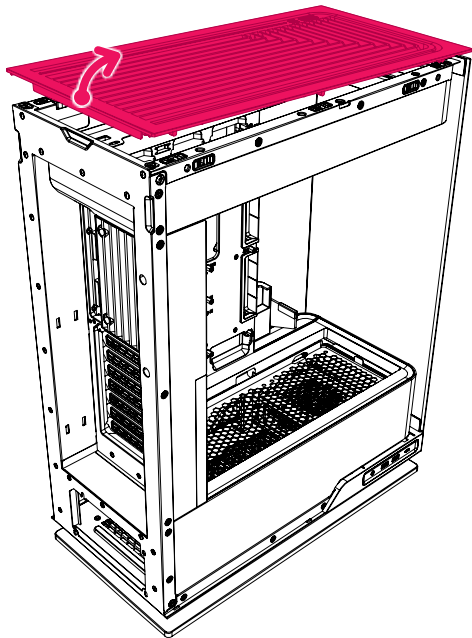

## 02 REMOVE SIDE PANEL SCREWS

Entfernen Sie die Schrauben der Seitenwand | Retirer les vis du panneau latéral | Quitar los tornillos del panel lateral | 卸下侧板螺丝



### PRO TIP

Secure the side panels when transporting the chassis.

**DE** Sichern Sie die Seitenwände beim Transport des Fahrgestells.

**FR** Fixez les panneaux latéraux lors du transport du châssis.

**ES** Asegure los paneles laterales al transportar el chasis.

**CN** 运输机箱时, 请固定好侧面板。

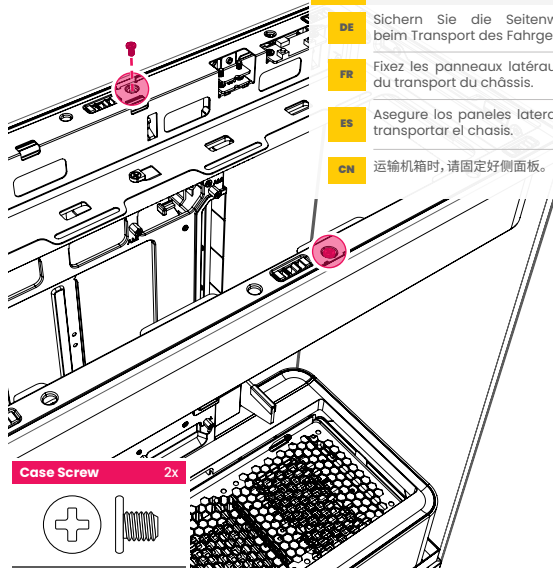

Case Screw 2x



# REMOVING EXTERNAL PANELS

Entfernen externer Bedienfelder | Retrait des panneaux externes | Quitar los paneles externos | 拆除外部面板

# EVOLV X<sup>2</sup>

## 03 REMOVE LEFT SIDE PANEL

Linke Seitenwand entfernen | Retirer le panneau latéral gauche | Quitar el panel lateral izquierdo | 移除左侧面板

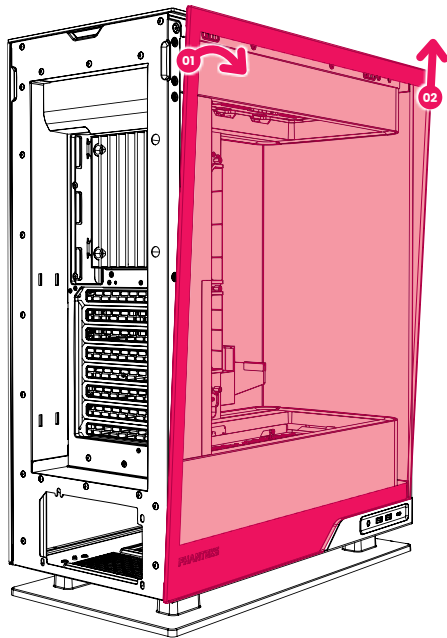

## 04 REMOVE RIGHT SIDE PANEL

Rechte Seitenwand entfernen | Retirer le panneau latéral droit | Quitar el panel lateral derecho | 卸下右侧面板

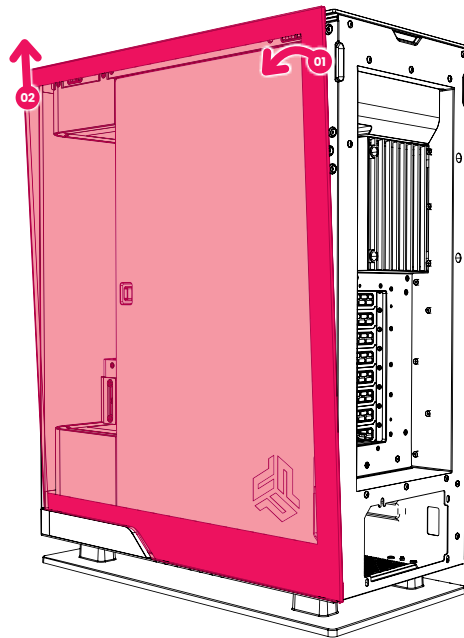

## INSTALL ATX MAINBOARD

ATX-Mainboard installieren | Installer la carte mère ATX | Instalar placa base ATX | 安装 ATX 主板

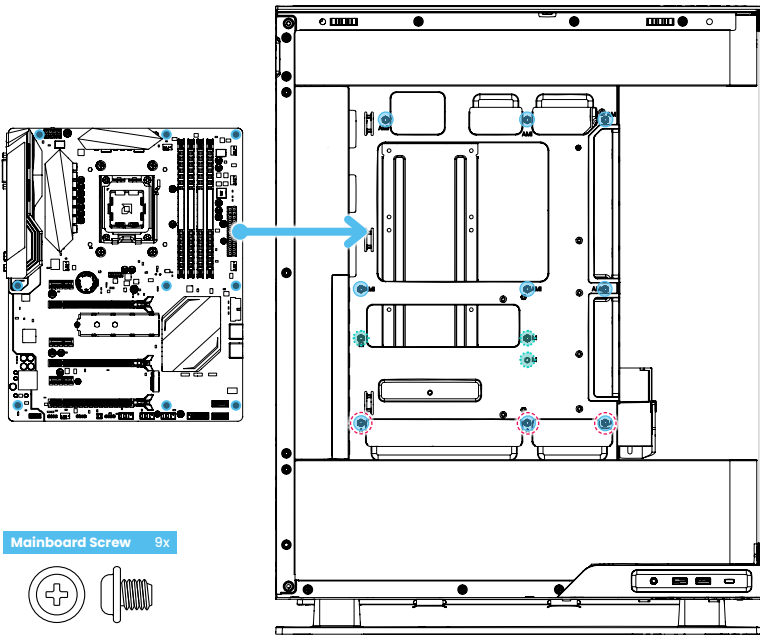

Mainboard Screw 9x



## INSTALL MICRO-ATX

Installieren Sie Micro-ATX | Installer Micro-ATX | Instalar Micro-ATX | 安装 Micro-ATX

For Micro-ATX boards, please refer to the mainboard manual for the correct installation.

Use the included stand-off tool to easily take out the mainboard stand-offs.

Micro-ATX Stand-off locations

Stand-off  
Removal Tool

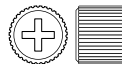

Mainboard  
Stand-off

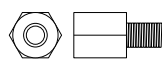

- DE** Bei Micro-ATX-Boards beachten Sie bitte die Anleitung zum korrekten Einbau des Mainboards. Mit dem mitgelieferten Abstandhalter-Werkzeug können Sie die Mainboard-Abstandhalter ganz einfach herausnehmen.
- FR** Pour les cartes Micro-ATX, veuillez vous référer au manuel de la carte mère pour une installation correcte. Utilisez l'outil de démontage fourni pour retirer facilement les supports de la carte mère.
- ES** Para las placas Micro-ATX, consulte el manual de la placa base para realizar la instalación correcta. Utilice la herramienta de separación incluida para quitar fácilmente los separadores de la placa base.
- CN** 对于 Micro-ATX 主板, 请参阅主板手册以了解正确安装方法。使用附带的支架工具可轻松取出主板支架。

## REMOVE PCIe COVER

PCIe-Abdeckung entfernen | Retirer le couvercle PCIe | Quitar la cubierta del PCIe | 移除 PCIe 盖

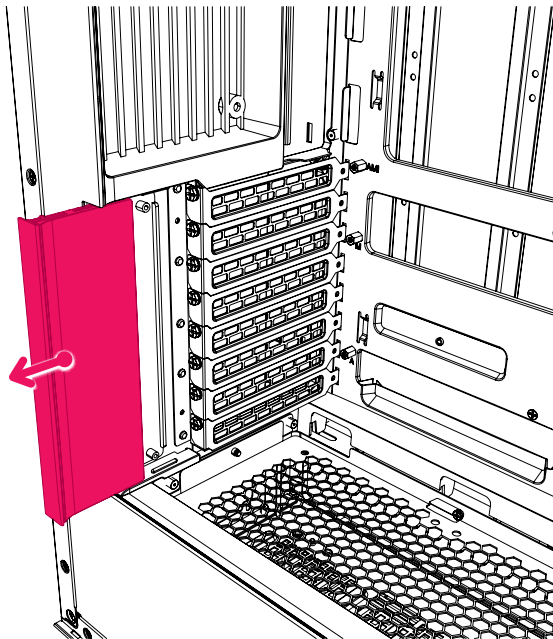

## ACCESS REAR PANEL

Zugang zur Rückseite | Accéder au panneau arrière | Acceder al panel trasero | 拆除后挡板

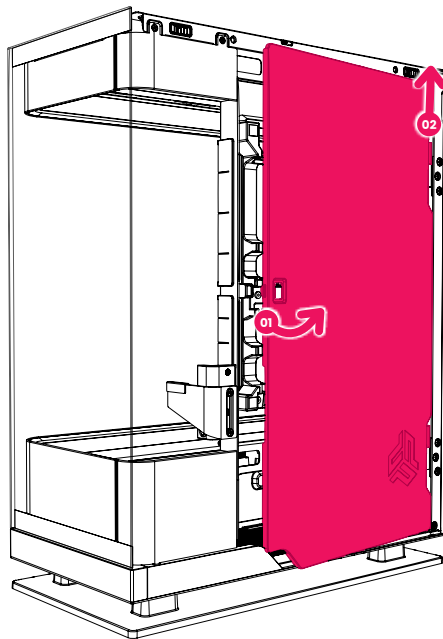

## INSTALL POWER SUPPLY

Installieren Sie das Netzteil | Installer l'alimentation électrique | Instalar fuente de alimentación | 安装电源

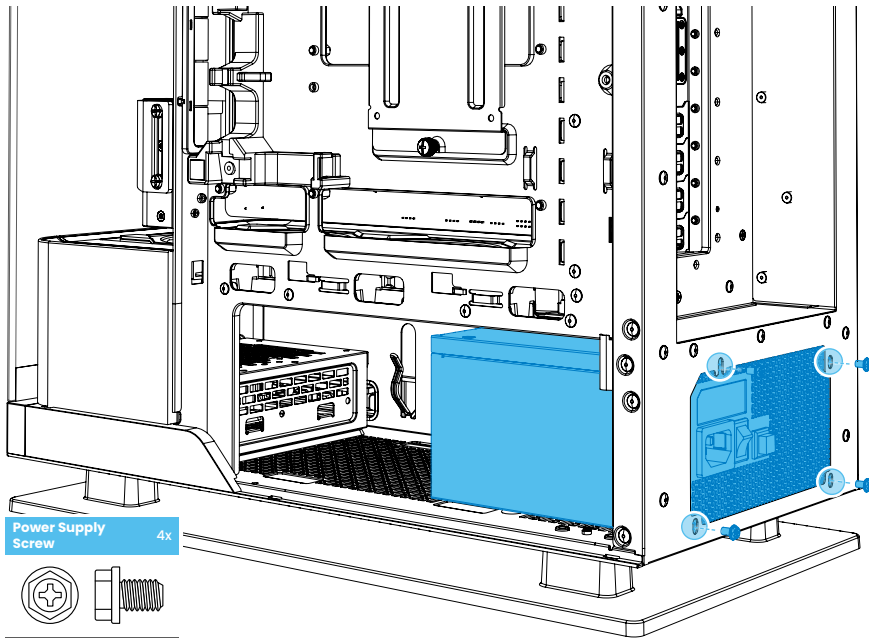

### PRO TIP

Attach all PSU cables first before installing the PSU into the chassis.

DE

Schließen Sie zunächst alle Netzteilkabel an, bevor Sie das Netzteil im Gehäuse installieren.

FR

Connectez d'abord tous les câbles du bloc d'alimentation avant d'installer le bloc d'alimentation dans le châssis.

ES

Conecte primero todos los cables de la PSU antes de instalar la PSU en el chasis.

CN

在将 PSU 安装到机箱中之前,请先连接所有 PSU 电缆。

## FANS

Fans | Les ventilateurs | Fanáticos | 粉丝

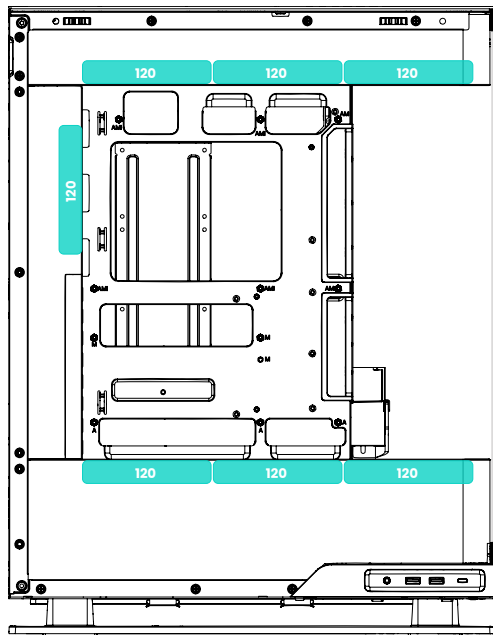

## RADIATOR

Kühler | Radiateur | Radiador | 散热器

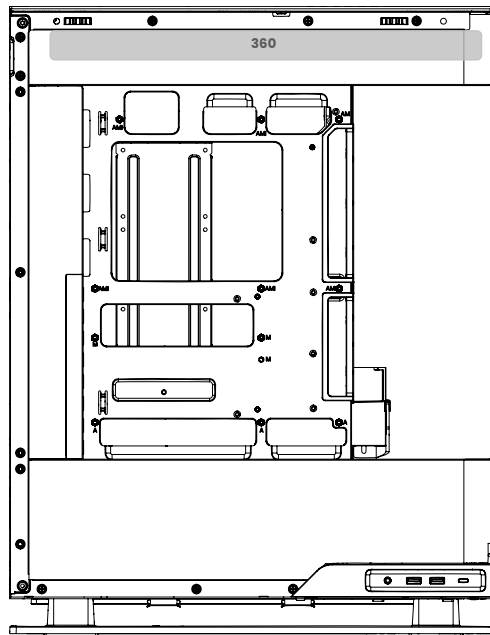

## 01 INSTALL BOTTOM FANS

Untere Lüfter installieren | Installer les ventilateurs inférieurs | Instalar ventiladores inferiores | 安装底部风扇

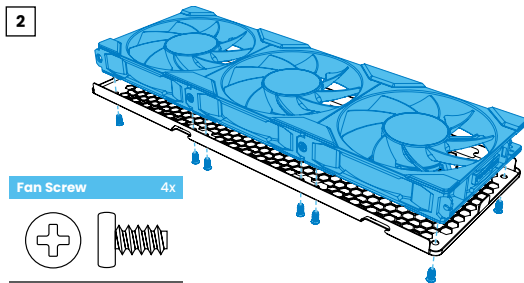
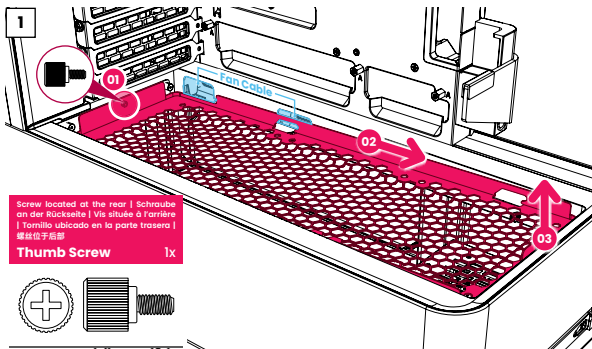

## 02 INSTALL REAR FAN

Installieren Sie den hinteren Lüfter | Installer le ventilateur arrière | Instalar ventilador trasero | 安装后风扇

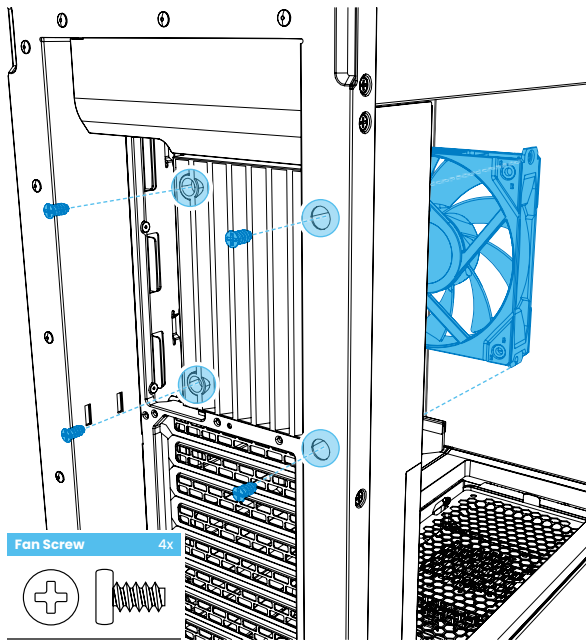

## 03 INSTALL TOP FANS & RADIATOR

installieren Sie die oberen Lüfter und den Kühler | Installer les ventilateurs supérieurs et le radiateur | instalar ventiladores superiores y radiador | 安装顶部风扇和散热器

1

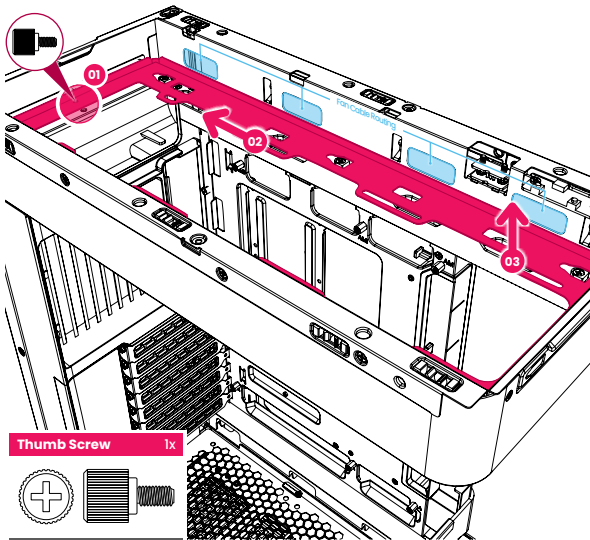

## 2A AIO TUBES REAR ORIENTATION

AIO-Röhren mit rückseitiger Ausrichtung | Orientation arrière des tubes AIO | Orientación trasera de los tubos AIO | AIO 管后向

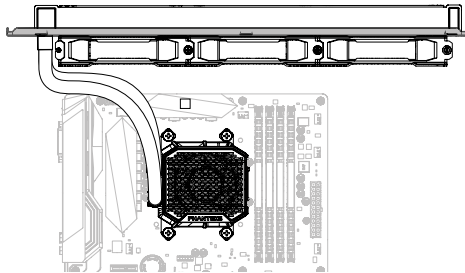

## 2B AIO TUBES FRONT ORIENTATION

AIO-Röhren – Ausrichtung nach vorne | Orientation avant des tubes AIO | Orientación frontal de los tubos AIO | AIO 管正方向

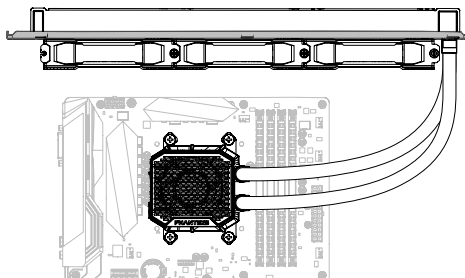

## 01 TRIPLE SSD BRACKET

Dreifache SSD-Halterung | Support triple SSD | Soporte triple para SSD | SSD硬盘支架

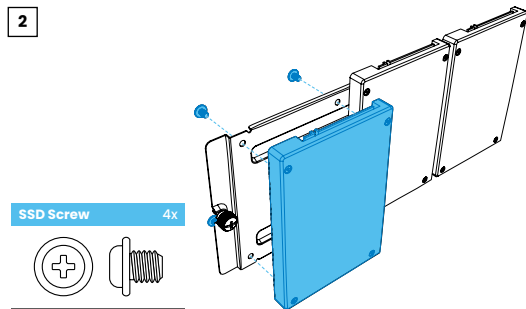
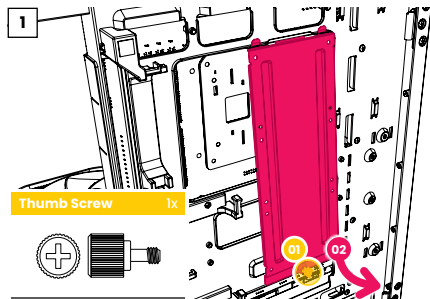

## 02 STORAGE BRACKET

Aufbewahrungshalterung | Support de rangement | Soporte de almacenamiento | HDD/SSD硬盘支架

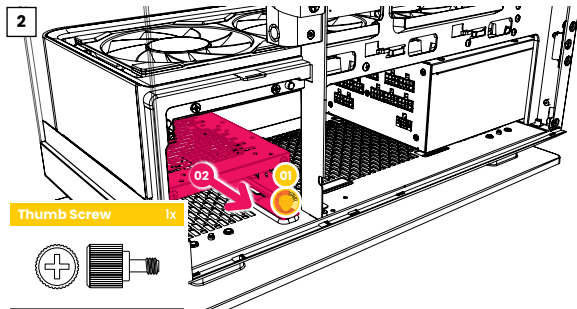
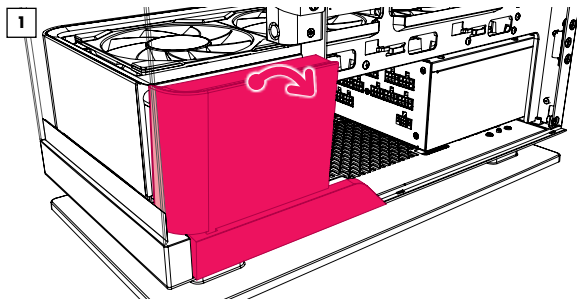

# INSTALLING STORAGE

Speicher installieren | Installation du stockage | Instalación de almacenamiento | 安裝存儲

# EVOLV X<sup>2</sup>

## 2A TOP 3.5" HDD

Oben 3.5-Zoll-Festplatte | Disque dur supérieur de 3.5 pouces | Disco duro superior de 3.5" | 頂級 3.5 英寸硬盤

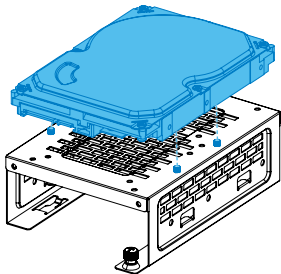

HDD Screw 4x



## 2B TOP DUAL 2.5" SSD

Top-Dual-2.5-Zoll-SSD | Double SSD supérieur de 2.5 pouces | SSD doble superior de 2.5" | 頂級雙 2.5" SSD

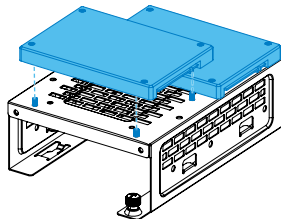

SSD Screw 4x



## 2C TOP SINGLE 2.5" SSD

Top Single 2.5-Zoll-SSD | Meilleur SSD unique de 2.5 pouces | SSD superior individual de 2.5" | 頂級單 2.5 英寸 SSD

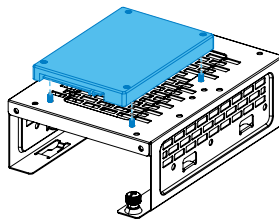

SSD Screw 4x



## 3 BOTTOM 3.5" HDD

Unten 3.5-Zoll-Festplatte | Disque dur inférieur de 3.5 pouces | Disco duro inferior de 3.5" | 底部 3.5 英寸硬盤

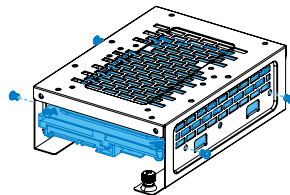

HDD Screw 4x



# CABLE ROUTING

Kabelführung | Acheminement des câbles | Enrutamiento de cables | 电缆布线

# EVOLV X<sup>2</sup>

## TOP I/O CABLE

Oberes E/A-Kabel | Câble E/S supérieur | Cable de E/S superior | 顶部 I/O 电缆

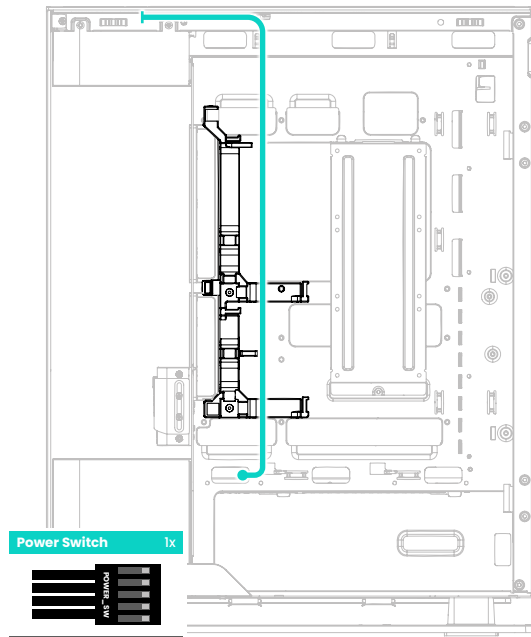

## SIDE I/O CABLES

Seitliche E/A-Kabel | Câbles d'E/S latéraux | Cables de E/S laterales | 侧面 I/O 电缆

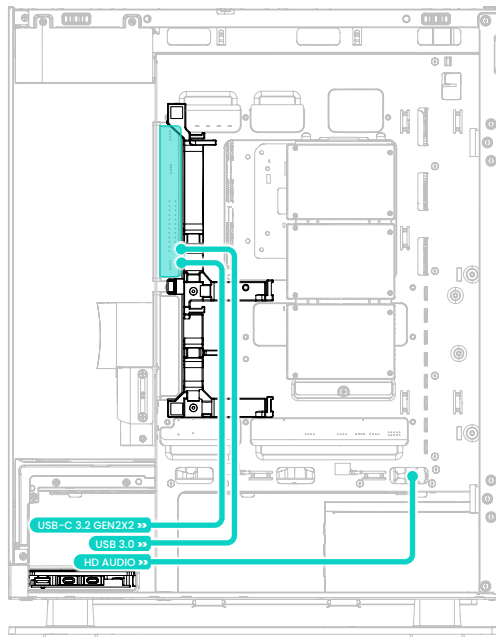

## PSU CABLE MANAGEMENT

Netzteil-Kabelmanagement | Gestion des câbles d'alimentation | Gestión de cables de la fuente de alimentación | PSU 电源管理

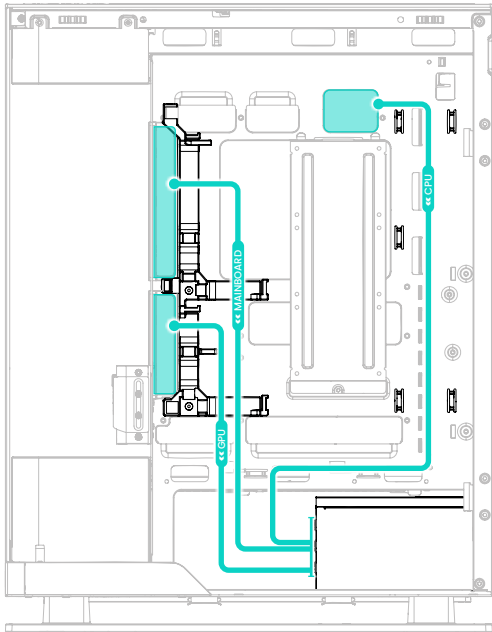

## STORAGE CABLE MANAGEMENT

SpeicherKabelmanagement | Gestion des câbles de stockage | Gestión de cables de almacenamiento | 存储线管理

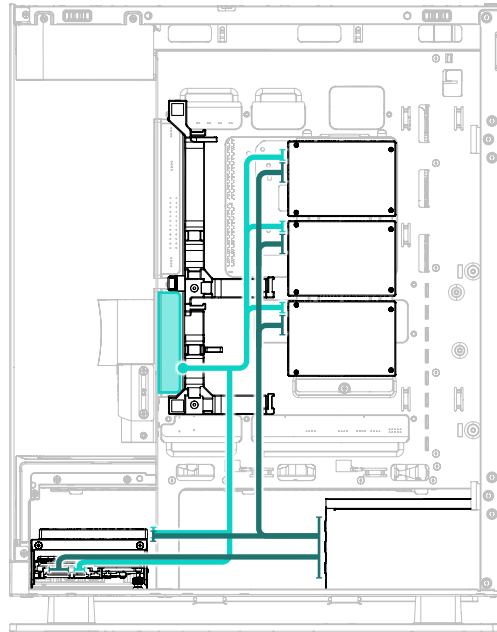

## LOOSEN GPU BRACKET

GPU-Halterung lösen | Desserrer le support du GPU | Afloje el soporte de la GPU | 松开 GPU 支架

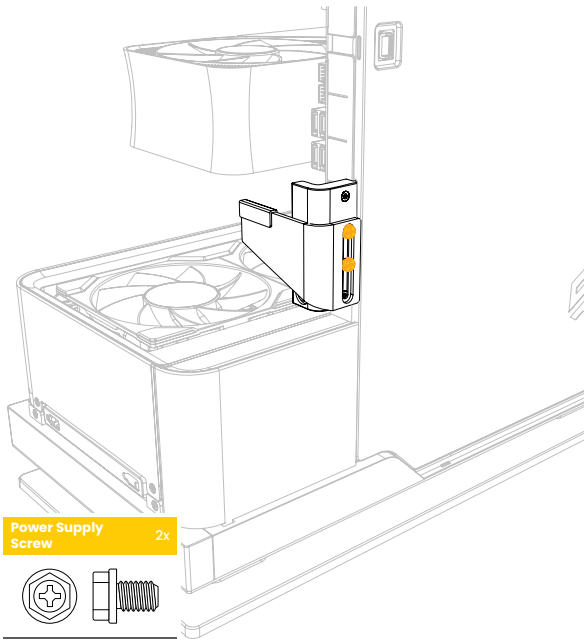

## ADJUST AND SECURE GPU BRACKET

GPU-Halterung anpassen und sichern | Ajuster et sécuriser le support du GPU | Ajuste y fijación del soporte de la GPU | 调整并固定 GPU 支架

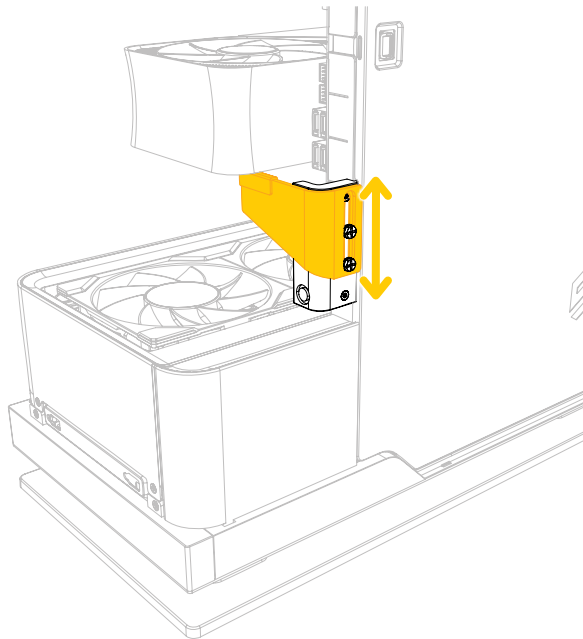

## DUST FILTERS

Staubfilter | Filtrés à poussière | Filtros de polvo | 除尘过滤器

# EVOLV X<sup>2</sup>

### BOTTOM DUST FILTER

Unterer Staubfilter | Filtré anti-poussière inférieur | Filtro de polvo inferior | 底部除尘过滤器

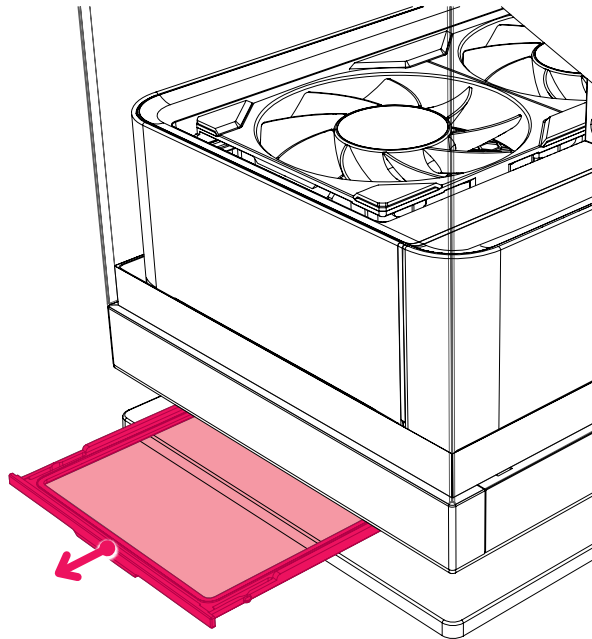

### TOP DUST FILTER

Oberer Staubfilter | Filtré à poussière supérieur | Filtro de polvo superior | 顶部除尘过滤器

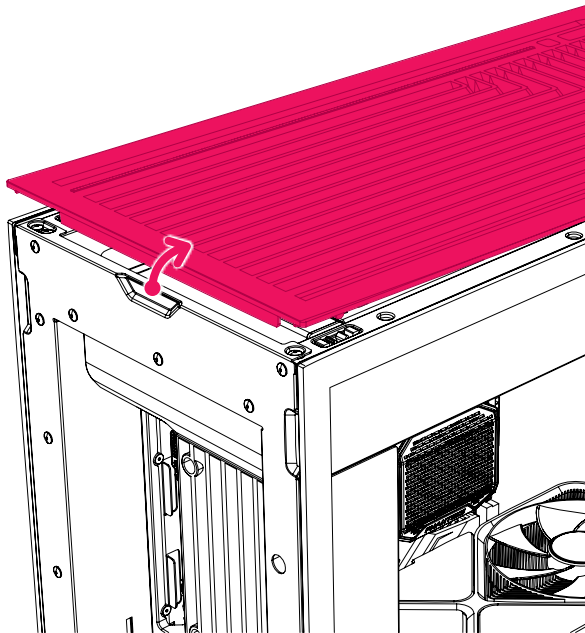

FOLLOW US  
**SOCIAL MEDIA**



Instagram



Facebook



YouTube



Twitter



ONLINE MANUAL  
ONLINE-HANDBUCH  
MANUEL EN LIGNE  
MANUAL EN LINEA  
在线手册