



Questo manuale d'istruzione è fornito da trovaprezzi.it. Scopri tutte le offerte per [Philips SHC5200M2](#)

Nero o cerca il tuo prodotto tra le [migliori offerte di Cuffie e Microfoni](#)

PHILIPS

Headphones
SHC5200M2



User manual

Register your product and get support at
www.philips.com/support

Contents

1	Important safety instructions	2
	Hearing safety	2
	General information	2

2	Your Digital TV headphones	4
	What's in the box	4
	Overview of your Digital TV headphones	5

3	Get started	6
	Charge the battery	6
	Change battery	6
	Connect to audio device with transmitter	7

4	Technical data	8
---	----------------	---

8	Notice	8
	Declaration of conformity	8
	Disposal of your old product and battery	8
	Remove the integrated battery	9
	Compliance with EMF	9
	Environmental information	9
	Notice of compliance	9

9	Frequently asked questions	10
---	----------------------------	----

1 Important safety instructions

Hearing safety



Danger

- To avoid hearing damage, limit the time you use headphones at high volume and set the volume to a safe level. The louder the volume, the shorter the safe listening time is.

Be sure to observe the following guidelines when using your headphones.

- Listen at reasonable volumes for reasonable periods of time.
- Be careful not to adjust the volume continuously upwards as your hearing adapts.
- Do not turn up the volume so high that you can't hear what's around you.
- You should use caution or temporarily discontinue use in potentially hazardous situations.
- Excessive sound pressure from earphones and headphones can cause hearing loss.
- Using headphones with both ears covered while driving is not recommended and may be illegal in some areas while driving.
- For your safety, avoid distractions from music or phone calls while in traffic or other potentially dangerous environments.

General information

The marking information is located at the bottom of apparatus.

The mains plug is used as the disconnect device.

The socket-outlet shall be installed near the equipment and shall be easily accessible.

To avoid damage or malfunction:

Caution

- Do not expose headphones to excessive heat.
- Risk of explosion if battery is replaced by an incorrect type.
- Do not drop your headphones.
- Headphones shall not be exposed to dripping or splashing. (Refer to the IP rating of specific product)
- Do not allow your headphones to be submerged in water.
- Do not charge your headphones when the connector or socket is wet.
- Do not use any cleaning agents containing alcohol, ammonia, benzene, or abrasives.
- Use a clean, damp cloth to clean your headphones - especially the sound conduits and the microphone holes - regularly and avoid buildup of substances such as sweat or earwax.
- If any sweat or water droplets are left in the sound conduits, air holes or microphone holes, the sound level will temporarily drop or cut out entirely. This is not a malfunction. Use a soft, damp cloth to dry the headphones thoroughly. Alternatively, remove the earbud tips, turn the sound conduits downward and gently tap the headphones about five times on a dry cloth or similar to remove any water collected inside.
- Be sure the headphones are completely dry before charging and using. Avoid using disposable alcohol pads or other substances for cleaning.
- The integrated battery shall not be exposed to excessive heat such as sunshine, fire or the like.
- Danger of explosion if battery is incorrectly replaced. Replace only with the same or equivalent type.
- To achieve the specific IP rating, the charging slot cover must be closed.
- Disposal of a battery into fire or a hot oven, or mechanically crushing or cutting a battery, can result in an explosion.

- Leaving a battery in an extremely high temperature surrounding environment can result in an explosion or the leakage of flammable liquid or gas.
- A battery subjected to extremely low air pressure may result in an explosion or the leakage of flammable liquid or gas.
- Replacement of a battery with an incorrect type risks severely damaging the headphones and the battery (for example, in the case of some lithium battery types).
- If the headset is not used for a long time, the rechargeable battery will begin to lose its charge. To avoid this loss, please fully charge the battery at least once every three months.
- To avoid risk of fire, the equipment is supplied only by external power source which output shall comply with PS1 (with output capacity does not exceed 15W).

Operating and storage temperatures and humidity

- Store in a place where the temperature is between -20°C (-4°F) and 50°C (122 °F) with up to 90% relative humidity.
- Operate in a place where the temperature is between 0°C (32°F) and 45°C (113 °F) with up to 90% relative humidity.
- Battery life may be shorter in high or low temperature conditions.

Warning

Don't disposal of a battery into fire or a hot oven, or mechanically crushing or cutting of a Battery.
 Don't leaving a battery in an extremely high temperature surrounding environment.
 To avoid battery subjected to extremely low air pressure.

 The symbol indicates DC voltage

 The symbol indicates class II equipment

 The symbol indicates AC voltage

 For indoor use only

-  **RECYCLING**
- This product bears the selective sorting symbol for Waste electrical and electronic equipment (WEEE). This means that this product must be handled pursuant to European directive 2012/19/EU in order to be recycled or dismantled to minimize its impact on the environment.
 - User has the choice to give his product to a competent recycling organization or to the retailer when he buys a new electrical or electronic equipment.

2 Your Digital TV headphones

Congratulations on your purchase, and welcome to Philips! To fully benefit from the support that Philips offer, register your product at www.philips.com/support. With this Philips Digital TV headphone, you can:

- Enjoy convenient wireless TV show;
- Enjoy and control wireless music.

What's in the box



Digital TV headphones Philips SHC5200M2



Transmitter

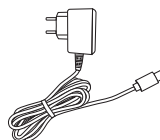

AC/DC adaptor

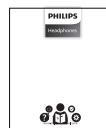

Quick start guide



Global Warranty



Safety leaflet

Overview of your Digital TV headphones

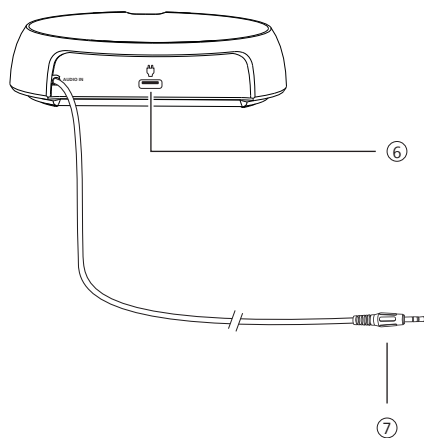
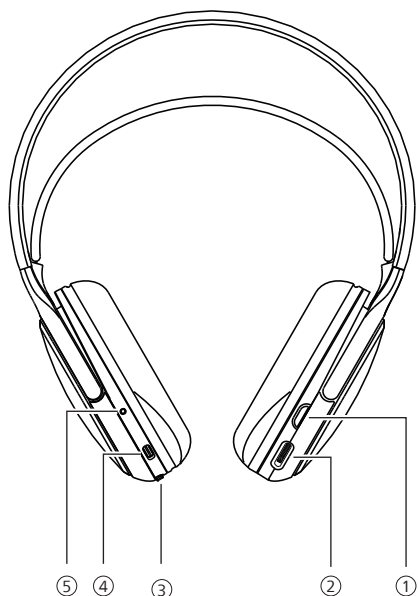

- ① Power ON / OFF
- ② Volume dial
- ③ Battery cover slide switch
- ④ Type-C charging slot (Headphone)
- ⑤ LED indicator
- ⑥ Type-C charging slot (Transmitter)
- ⑦ 3.5mm audio jack

3 Get started

Charge the battery

Note

- Before you use your headphones, charge the battery for 3 hours for optimum battery capacity and lifetime.
- Use only the original AC/DC adaptor to avoid any damage.
- If the headset is not used for a long time, the rechargeable battery will begin to lose its charge. To avoid this loss, please fully charge the battery at least once every three months.

Plug one end of the AC/DC adaptor into the headphone and the other end into the power source.

- ↳ LED turns green during charging and turns off when the headphones are fully charged.

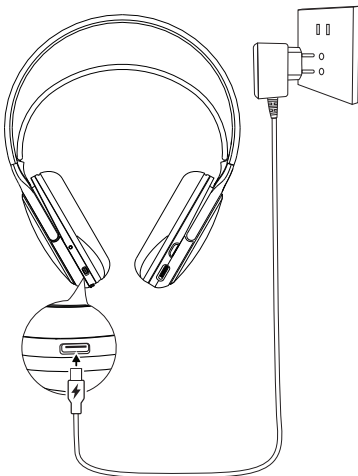

Tip

- Normally, a full charge takes 3 hours.

Change battery

- 1 Push the battery cover slide switch to open the cover.
- 2 Remove the battery and replace it with a new one.

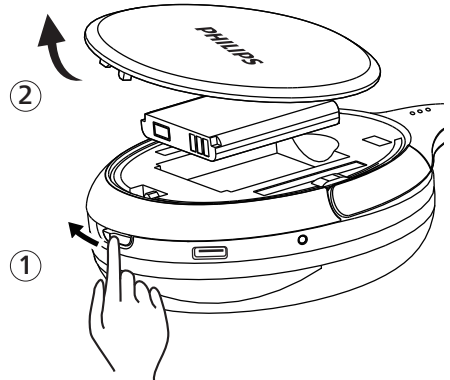

Connect to audio device with transmitter

- 1 Press the power ON/OFF button on the headphone for 2 seconds to turn it on; the red LED light will flash.
- 2 Connect the transmitter to power via the AC/DC adapter; the power LED indicator will flash red.
- 3 Connect the audio device to the transmitter via the 3.5mm audio jack; the signal LED indicator will flash green.

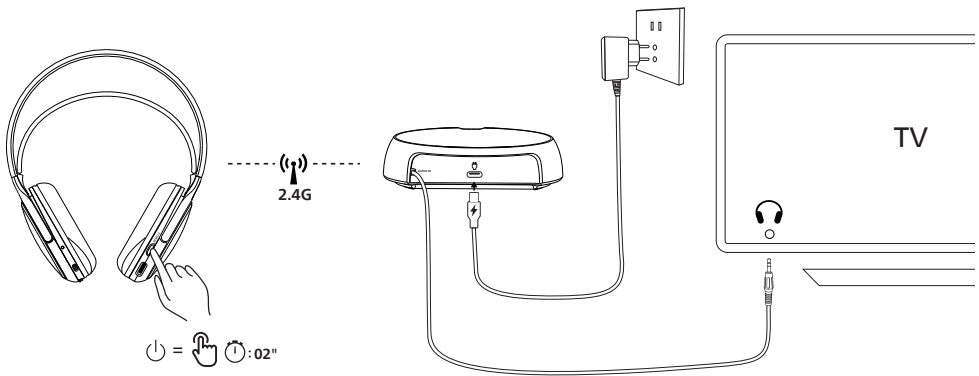

4 Technical data

- Playing time: 30 hours
- Charging time: 3 hours
- Battery: Rechargeable lithium-polymer battery (3.7V 600 mAh)
- Adapter: YLJXB-E050055
input: 100-240Vac, 50/60Hz, 05A Max
output: 5Vdc, 0.55A, 2.75W
- Frequency range: 2.4-2.4835 GHz
- Transmitter power: < 20 dBm
- Operating range: Up to 30 meters (98 feet)
- USB-C port for charging
- 3.5mm input switch
- 2.4G RF solution
- Fast charging: 15 mins gives 4 hrs playing



Note

- Specifications are subject to change without notice.
- Battery life of playtime is approximate and may vary depending on application condition.

5 Notice

Declaration of conformity

Hereby, TP Vision Europe B.V. declares that the product is in compliance with the essential requirements and other relevant provisions of RED Directive 2014/53/EU and UK Radio Equipment Regulations SI 2017 No 1206. You can find the Declaration of Conformity on www.philips.com/support.

Disposal of your old product and battery



Your product is designed and manufactured with high quality materials and components which can be recycled and reused.



This symbol on a product means that the product is covered by European Directive 2012/19/EU.



This symbol means that the product contains batteries covered by European Regulation (EU) 2023/1542 which cannot be disposed of with normal household waste. Inform yourself about the local separate collection system for electrical and electronic products and batteries. Follow local rules and never dispose of the product and batteries with normal household waste. Correct disposal of old products and batteries helps prevent negative consequences for the environment and human health.

Remove the integrated battery

If there is no collection/recycling system for electronic products in your country, you can protect the environment by removing and recycling the battery before disposing of the headphones.

- Make sure the headphones are disconnected before removing the battery.

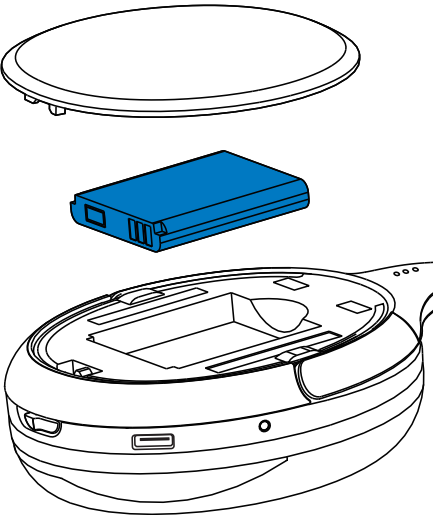

Compliance with EMF

This product complies with all applicable standards and regulations regarding exposure to electromagnetic fields.

Environmental information

All unnecessary packaging has been omitted. Your system consists of materials which can be recycled and reused if disassembled by a specialized company. Please observe the local regulations regarding the disposal of packaging materials, exhausted batteries and old equipment.

Notice of compliance

The device complies with the FCC rules, Part 15. Operation is subject to the following two conditions:

1. This device may not cause harmful interference, and
2. This device must accept any interference received, including interference that may cause undesired operation.

6 Frequently asked questions

My Digital TV headphones do not turn on.

The battery level is low. Charge via AC/DC adapter for 3 hours.

Why won't my headphone connect to the TV?

Headphones use 2.4GHz wireless technology with a maximum range of 30 meters (98 feet). Connection failures occur when:

- Distance exceeded - Move closer to the transmitter (within 30m)
- Obstructions present - Remove walls/metal objects between transmitter and headphones
- Interference sources - Turn off nearby Wi-Fi routers, microwaves, or Bluetooth devices

The audio quality is poor and crackling noise can be heard.

- Check cable integrity: Bent or frayed wires cause interference.
- Clean the audio jack: Dust in the TV/headphone port disrupts connection. Use compressed air.
- Adjust the volume dial: Over-amplification distorts sound. Keep dial below 80% max.

No sound from one earcup.

- Swap audio channels: Test left/right balance in TV settings.
- Inspect cable symmetry: Partially inserted jacks create mono audio. Reconnect firmly.
- Check earcup vents: Blocked airflow muffles sound. Clean mesh with soft brush.

Clean your headphones regularly.

- Use a clean, damp cloth to clean your headphones - especially the sound conduits and the microphone holes - regularly and avoid buildup of substances such as sweat or earwax.
- If any sweat or water droplets are left in the sound conduits, air holes or microphone holes, the sound level will temporarily drop or cut out entirely. This is not a malfunction. Use a soft, damp cloth to dry the headphones thoroughly. Alternatively, for in-ear remove the earbud tips, turn the sound conduits downward and gently tap the headphones about five times on a dry cloth or similar to remove any water collected inside.
- Be sure the headphones are completely dry before charging and using. Avoid using disposable alcohol pads or other substances for cleaning.

Charge your headphones regularly.

If the headset is not used for a long time, the rechargeable battery will begin to lose its charge. To avoid this loss, please fully charge the battery at least once every three months.

For further support, visit www.philips.com/support.



2025©MMD Hong Kong Holding Limited. All rights reserved. Specifications are subject to change without notice. Philips and the Philips Shield Emblem are registered trademarks of Koninklijke Philips N.V. and are used under license. This product has been manufactured by and is sold under the responsibility of MMD Hong Kong Holding Limited or one of its affiliates, and MMD Hong Kong Holding Limited is the warrantor in relation to this product. All other company and product names may be trademarks of their respective companies with which they are associated.

UM_SHC5200M2_12_EN_V1.0

