

playmobil®

**BACK
TO THE
FUTURE**



78317

Wir schreiben das Jahr 1985 – aber nicht lange! Marty McFly lebt ein ganz normales Teenager-Leben, zumindest bis ihn die neueste Erfindung des exzentrischen Wissenschaftlers „Doc“ Brown, eine durch Plutonium angetriebene DeLorean-Zeitmaschine, ins Jahr 1955 katapultiert. Dort angekommen, hindert Marty seine Eltern versehentlich daran, sich zu verlieben. Mit fatalen Folgen, denn nicht nur Marty und seine Geschwister sind durch die Veränderung der Vergangenheit in Gefahr, sondern die ganze Zukunft! So hat er keine andere Wahl, als die Geschichte noch weiter zu verändern, um Zurück in die Zukunft zu gelangen.

The year is 1985 – but not for long. Because teenager Marty McFly is about to be blasted back to 1955 aboard the plutonium-powered DeLorean created by eccentric genius Doc Emmett Brown. But when Marty accidentally keeps his parents-to-be from falling in love, it triggers a time-shattering chain reaction that could vaporise his future – and leave him trapped in the past! Now, Marty's last hope is to change history – before the clock runs out on his only chance to get himself Back to the Future!

Nous sommes en 1985 - mais pas pour longtemps ! Marty McFly mène une vie d'adolescent tout à fait normale, du moins jusqu'à ce qu'il croise la dernière invention de l'excentrique professeur « Doc » Brown : une DeLorean boostée au plutonium, qui le propulse jusqu'en 1955. Une fois sur place, Marty empêche accidentellement ses parents de tomber amoureux l'un de l'autre. Les conséquences sont fatales, car ce ne sont pas uniquement Marty et ses frères et sœurs qui sont en danger en changeant le passé, mais le futur en général ! Il n'a donc pas d'autre choix que de continuer à modifier le cours de l'histoire pour retourner à son époque d'origine.

Nos encontramos en el año 1985, aunque no por mucho tiempo... Marty McFly tiene una vida de adolescente completamente normal, al menos hasta que se topa con el nuevo invento del excéntrico científico «Doc» Brown. El invento consiste en la máquina del tiempo DeLorean, propulsada con plutonio, y que lo catapulta hasta el año 1955. Una vez en ese año, Marty evita por error que sus padres se enamoren. Esto supone fatales consecuencias, porque debido a este cambio en el pasado no solo están en peligro él y sus hermanos, ¡sino todo el futuro! De este modo, no dispone de otra alternativa que continuar alterando la historia para poder volver al futuro.

BACK TO THE FUTURE

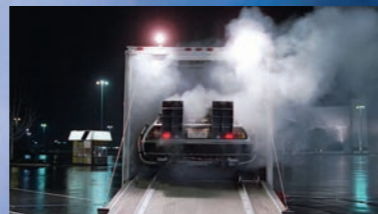

DELOREAN

DR. EMMETT BROWN

MARTY MCFLY

EINSTEIN



WARNING: CHOKING HAZARD

Small parts. Not for children under 3 years.

"Ne concerne que les USA"

Wichtige Unterlagen, bitte sorgfältig aufbewahren!
Important: Please keep these instructions for future reference!
Documents importants, à conserver soigneusement!
¡Por favor, guarde estas instrucciones para el futuro!
Belangrijke documenten, bewaar deze zorgvuldig!

Abbildungen können vom Original abweichen.
Product may differ from image shown.
Les illustrations peuvent différer de l'original.
Las ilustraciones pueden diferir del original.
Afbeeldingen kunnen verschillen van het werkelijke artikel.

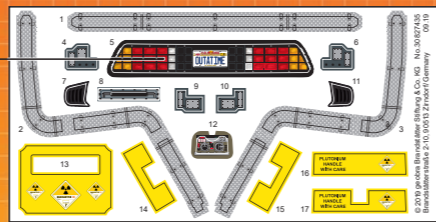
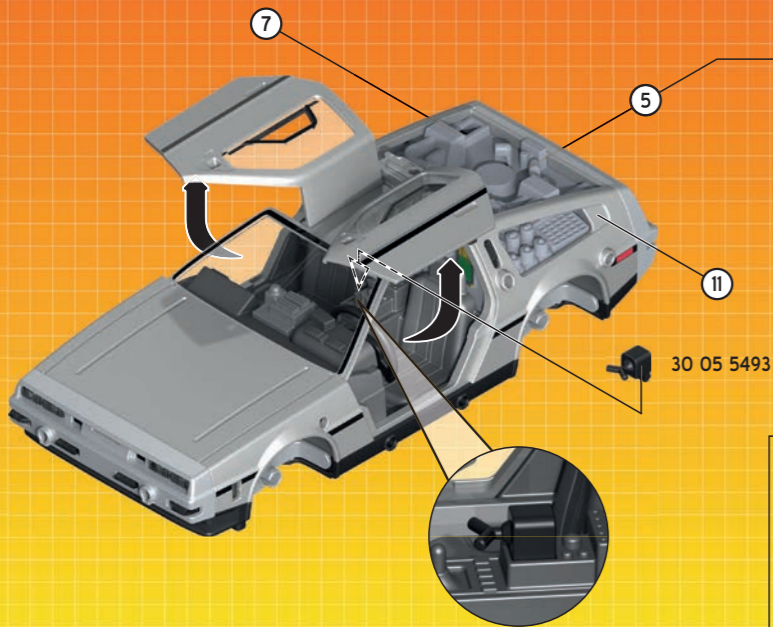

30 82 7435

Serviceadressen finden Sie in allen
PLAYMOBIL-Prospekten
Addresses of Customer Service Depart-
ments are shown in all PLAYMOBIL
catalogues
L'adresse du service consommateurs
est indiquée dans tous les catalogues
PLAYMOBIL
Troverete gli indirizzi dei centri di
assistenza in tutti i cataloghi PLAYMOBIL

In alle PLAYMOBIL catalogi vindt u
het adres van onze klantendienst.
Las Direcciones de los Departamentos
de Servicio al Consumidor se encuentran
en todos los catálogos PLAYMOBIL
Η διεύθυνση του Γραφείου Εξυπηρέτησης
Καταναλωτών PLAYMOBIL βρίσκεται σε
όλους τους καταλόγους PLAYMOBIL.
pronounced: plāymō-bēēl

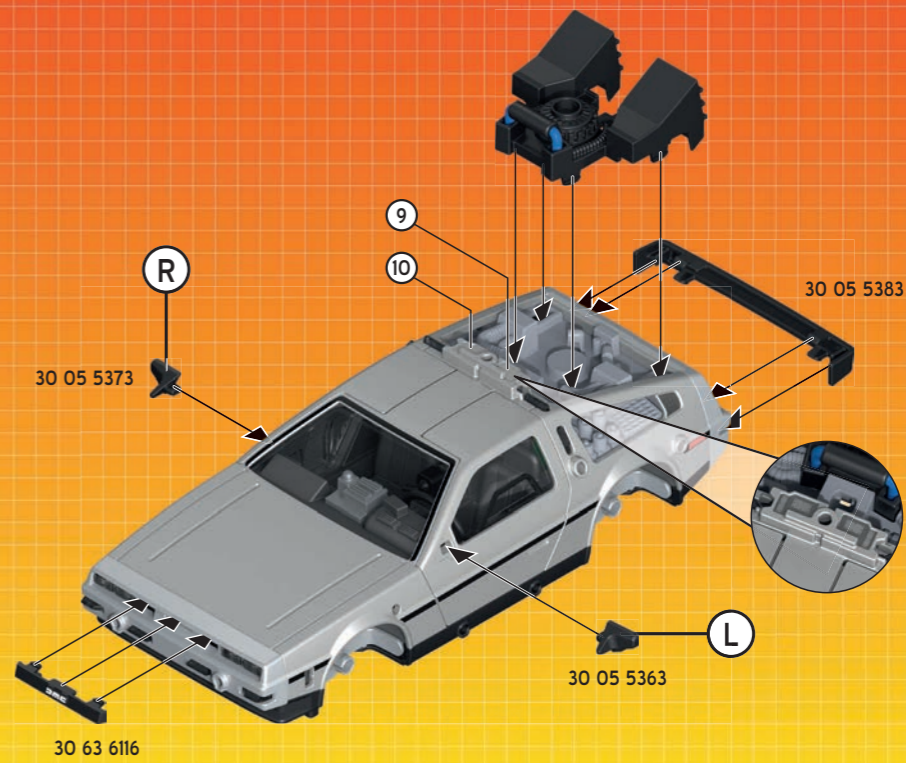
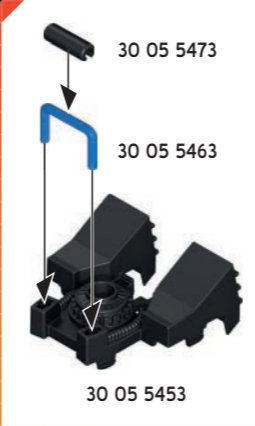

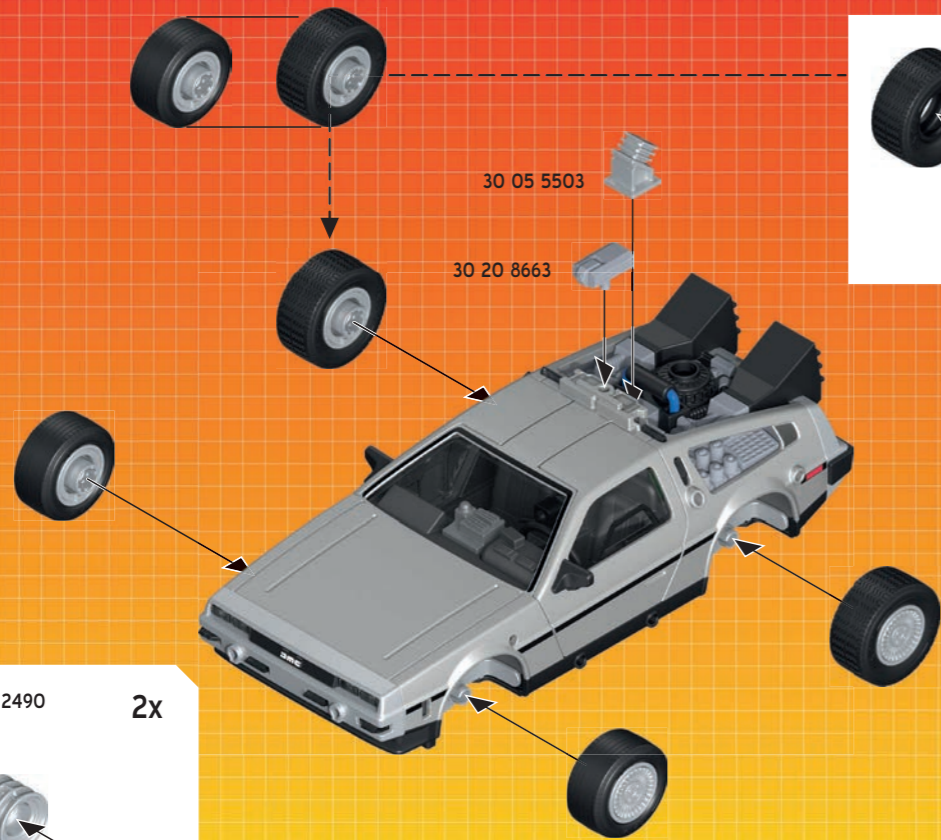

30 05 5503

30 20 8663

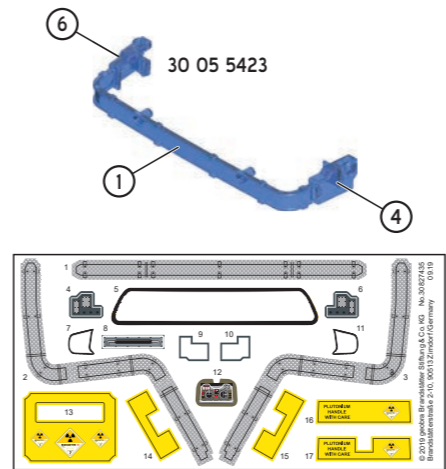
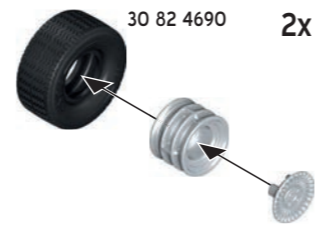

30 05 5643

30 04 4262

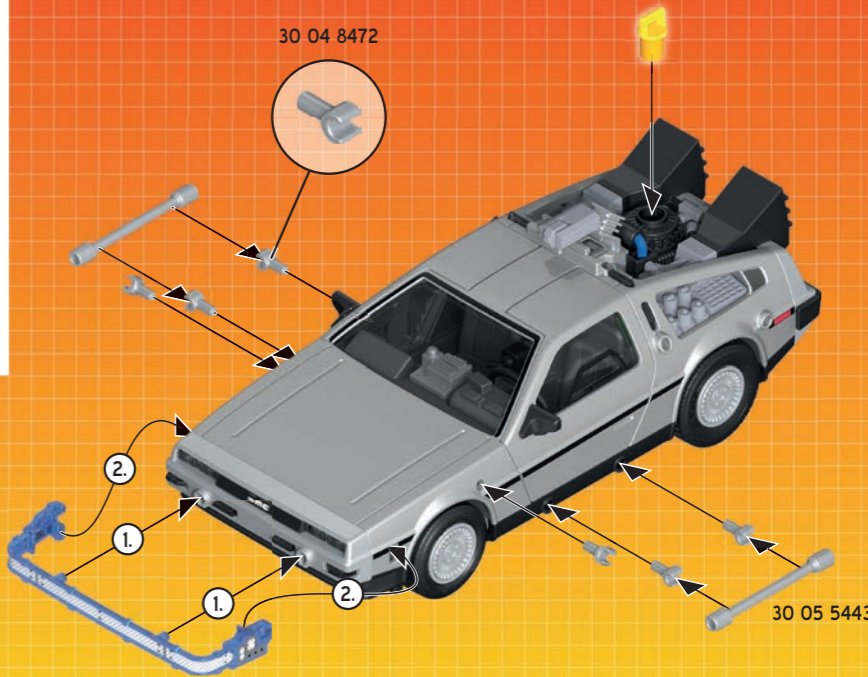

5



30 23 5630



6

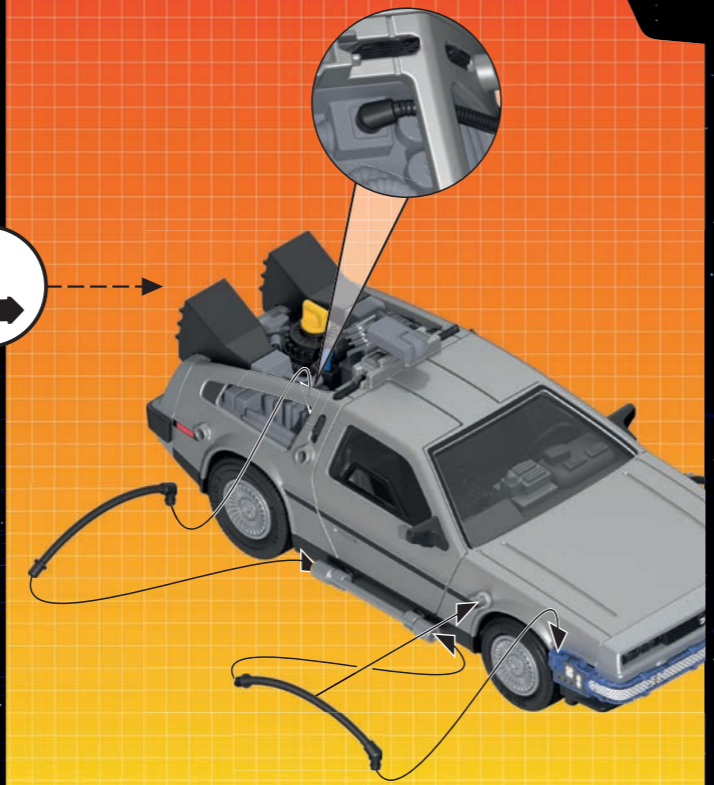

8

ASSEMBLY INSTRUCTION

7

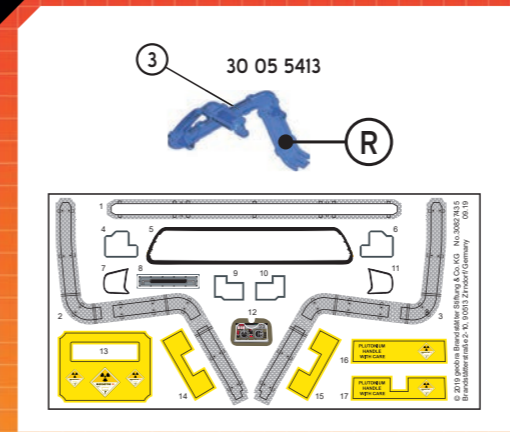

30 05 5513

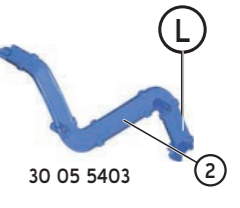

30 05 5403

9

ASSEMBLY INSTRUCTION



2x MICRO 1.5V
RO3 - LRO3 - AAA



30 65 4734

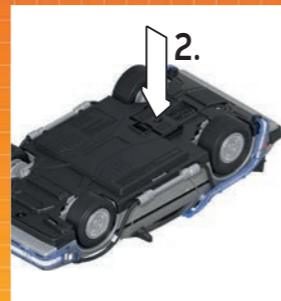
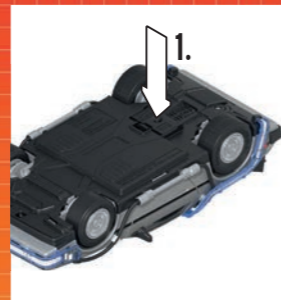

AUS / OFF
ARRÊT



DE AT CH LU BE ACHTUNG! Das Spielzeug erzeugt Lichtblitze, die bei empfindlichen Personen Epilepsie auslösen können.

US GB CA MT IE WARNING! This toy produces flashes that may trigger epilepsy in sensitised individuals.

FR CA BE LU CH ATTENTION! Ce jouet crée des flashes lumineux susceptibles de déclencher des crises d'épilepsie chez certaines personnes.

ES MX ¡ADVERTENCIA! El juguete genera destellos de luz que, en personas sensibles, pueden provocar epilepsia.

NL BE WAARSCHUWING! het speelgoed veroorzaakt lichtflitsen, die bij gevoelige personen epilepsie kunnen veroorzaken.

IT CH AVVERTENZA! Il giocattolo genera lampi di luce che possono provocare epilessia nei soggetti sensibili.

PT ATENÇÃO! O brinquedo imite raios de luz que, em caso de pessoas sensíveis pode provocar epilepsia.

DK ADVARSEL! Dette legetøj frembringer lysglimt, der kan fremprovokere epileptiske anfald hos særlig følsomme mennesker.

NO ADVARSEL! Leketøyet fremkaller lynlys som kan utløse epilepsi hos ømfintlige personer.

SE FI VARNING! Den här leksaken avger ljusblixtar, som kan utlösa epilepsi hos känsliga personer.

FI VAROITUS! Lelu välkky ja voi aiheuttaa epilepsia-kohtauksen herkimille henkilöille.

HU FIGYELMEZTETÉS! A játékszer fényfelvillanásokat okoz, amely az arra érzékeny személyeknél epilepsziás rohamokat válthat ki!

CZ UPOZORNĚNÍ! Hračka vydává světelné záblesky, které mohou u citlivých osob vyvolat epilepsii.

EE HOIATUS! Mänguasi tekitab valgusvõlgatusi, mis võivad tundlikel inimestel vallandada epileptilisi hoogusid.

LV BRĪDINĀJUMS! Rotaļlietai darbojoties, rodas gaismas zibšņi, kas var izraisīt epilepsijas lēkmi jutīgām personām.

LT ĮSPĖJIMAS! Žaislas generuoja šviesos blyksnius, kurie jautriems asmenims gali sukelti epilepsiją.

SI OPOZORILO! Igrača oddaja bliske, ki pri občutljivih osebah lahko lahko sprožijo epileptične napade.

SK UPOZORNENIE! Hračka vytvára záblesky svetla, ktoré môžu u citlivých osôb vyvolať epilepsiu.

PL OSTRZEŻENIE! Zabawka wytwarza błyski, które u osób wrażliwych mogą wywoływać napady epilepsji.

TR CY ΔΙΚΚΑΤ! Oyuncak, hassas kişilerde epilepsi nöbetine neden olabilecek ışık flaşları oluşturmaktadır.

GR CY ΠΡΟΕΙΔΟΠΟΙΗΣΗ! Το παιχνίδι παράγει αστραπιαίο φως που μπορεί να προκαλέσει επιληψία σε ευαίσθητα άτομα.

RO AVERTISMENT! Jucăria produce pulsuri de lumină care pot declanșa crize de epilepsie la persoanele sensibile.

BG Внимание! Игрчката произвежда светкавици, които могат да предизвикат епилепсия при чувствителни лица.

HR UPOZORENJE! Igračka proizvodi bljeskove koji kod osjetljivih osoba mogu izazvati epilepsiju.

CN 警告! 本玩具产生闪光, 在敏感者有导致癫痫发作的可能。



(DE AT CH LU BE) Denken Sie an den Schutz der Umwelt !

- Ihr Gerät enthält wertvolle Rohstoffe, die wieder verwertet werden können.
- Geben Sie Ihr Gerät deshalb bitte bei einer Sammelstelle Ihrer Stadt oder Gemeinde ab.

(GB MT IE) Environment protection first !

- Your appliance contains valuable materials which can be recovered or recycled.
- Leave it at a local civic waste collection point.

(FR LU CH) Participons à la protection de l'environnement !

- Votre appareil contient de nombreux matériaux valorisables ou recyclables.
- Confiez celui-ci dans un point de collecte pour que son traitement soit effectué.

(ES) ¡¡ Participe en la conservación del medio ambiente !!

- Su electrodoméstico contiene materiales recuperables y/o reciclables.
- Entréguelo al final de su vida útil, en un Centro de Recogida Específico o en uno de nuestros Servicios Oficiales Post Venta donde será tratado de forma adecuada.

(NL BE) Samen het milieu beschermen !

- Uw product bevat meerdere recycleerbare materialen
- Breng deze naar een afval-inzamelpunt.

(BE) Participons à la protection de l'environnement !

- Votre appareil contient de nombreux matériaux valorisables ou recyclables.
- Confiez celui-ci dans un point de collecte ou à défaut dans un centre service agréé pour que son traitement soit effectué.

(IT CH) Partecipiamo alla protezione dell'ambiente !

- Il vostro apparecchio è composto da diversi materiali che possono essere riciclati.
- Lasciatelo in un punto di raccolta o presso un Centro Assistenza Autorizzato.

(PT) Protecção do ambiente em primeiro lugar!

- O seu produto contém materiais que podem ser recuperados ou reciclados.
- Entregue-o num ponto de recolha para possibilitar o seu tratamento.

(DK) Vi skal alle være med til at beskytte miljøet!

- Apparatet indeholder mange materialer, der kan genvindes eller genbruges.
- Bring det til et specialiseret indsamlingssted for genbrug eller et autoriseret serviceværksted, når det ikke skal bruges mere.

(SE FI) Var rädd om miljön!

- Din apparat innehåller olika material som kan återanvändas eller återvinnas.
- Lämnna den på en återvinningsstation eller på en auktoriserad serviceverkstad för omhändertagande och behandling.

(FI) Huolehtikaamme ympäristöstä!

- i Laitteesi on varustettu monilla arvokkailla ja kierrätettävillä materiaaleilla.
- Toimita laitteesi keräyspisteeseen tai sellaisen puuttuessa vaikka valtuutettuun huoltokeskukseen, jotta laitteen osat varmasti kierrätetään.

(HU) Első a környezetvédelem!

- Az Ön terméké értékes újrahaznosítható anyagokat tartalmaz.
- Kérjük készülékét ne dobja ki, hanem adja le az erre a célra kijelölt gyűjtőhelyen.

(CZ) Podílejme se na ochraně životního prostředí!

- Váš přístroj obsahuje čtené zhodnotitelné nebo recyklovatelné materiály.
- Svrte je sběrnému místu nebo, neexistuje-li, smluvnímu servisnímu středisku, kde s ním bude naloženo odpovídajícím způsobem.

(SI) Sodelujmo pri varovanju okolja!

- Vaš aparat vsebuje številne dele, ki imajo svojo vrednost ali jih je še mogoče uporabiti.
- Oddajte ga na mestu za zbiranje odpadkov ali pa na pooblaščenem servisu, da bo šel v predelavo.

(SK) Podieľajme sa na ochrane životného prostredia!

- Váš prístroj obsahuje čtené zhodnotiteľné alebo recyklovateľné materiály.
- Zverte ho sběrnému miestu alebo, ak neexistuje, zmluvnému servisnému stredisku, kde s ním bude naložené zodpovedajúcim spôsobom.

(PL) Bierzmy czynny udział w ochronie środowiska!

- Twoje urządzenie jest zbudowane z materiałów, które mogą być poddane ponownemu przetwarzaniu lub recyklingowi.
- W tym celu należy je dostarczyć do wyznaczonego punktu zbiórki.

(GR CY) Ας συμβάλουμε κι εμείς στην προστασία του περιβάλλοντος!

- Η συσκευή σας περιέχει πολλά αξιοποιήσιμα ή ανακυκλώσιμα υλικά.
- Παραδώστε την παλιά συσκευή σας σε κέντρο διαλογής ή σε ένα εξουσιοδοτημένο κατάστημα σέρβις.

(RO) Țineți cont de protecția mediului !

- Aparatul dvs. conține materii prime valoroase care pot fi revalorificate.
- Din acest motiv vă rugăm să predați aparatul dvs. la un centru de colectare din orașul sau comuna dvs.

(BG) Мислете за околната среда !

- Вашият уред съдържа ценни суровини, които могат да бъдат рециклирани.
- Затова върнете своя електроуред на специално място за събиране на такива отпадъци във Вашия град или община.

(US)

NOTE: This equipment has been tested and found to comply with the limits for a Class B digital device, pursuant to part 15 of the FCC Rules. These limits are designed to provide reasonable protection against harmful interference in a residential installation. This equipment generates, uses and can radiate radio frequency energy and, if not installed and used in accordance with the instructions, may cause harmful interference to radio communications. However, there is no guarantee that interference will not occur in a particular installation. If this equipment does cause harmful interference to radio or television reception, which can be determined by turning the equipment off and on, the user is encouraged to try to correct the interference by one or more of the following measures:

- Reorient or relocate the receiving antenna.
- Increase the separation between the equipment and receiver.
- Connect the equipment into an outlet on a circuit different from that to which the receiver is connected.
- Consult the dealer or an experienced radio/TV technician for help.

PLAYMOBIL USA, INC.
26 Commerce Drive
Cranbury, NJ 08512
Phone 1-800-752-9662 or
609-395-5566
Email: service@playmobilusa.com

Caution: Changes or modifications not expressly approved by the party responsible for compliance could void the user's authority to operate the equipment.

(US)

This device complies with Part 15 of the FCC Rules. Operation is subject to the following two conditions:
(1) This device may not cause harmful interference, and
(2) This device must accept any interference received, including interference that may cause undesired operation.

(CA) CAN ICES-3 (B)/NMB-3(B)

Cet équipement est conforme à la Section 15 des règlements de la FCC. Son fonctionnement est soumis aux deux conditions suivantes:
(1) Cet équipement ne peut causer d'interférence nuisible, et
(2) cet équipement doit pouvoir fonctionner même s'il capte de l'interférence, incluant celle pouvant provoquer un fonctionnement indésirable.

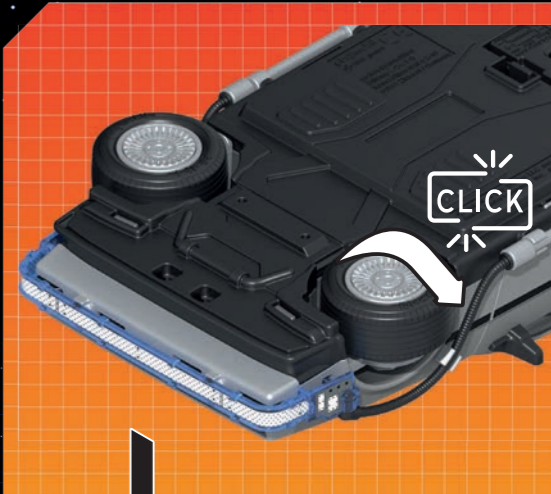

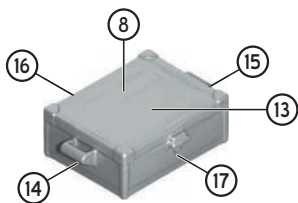
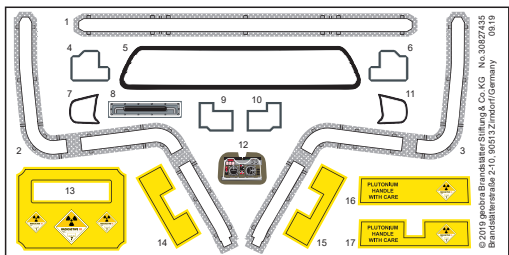

30 05 5633



30 63 6156

30 07 0250

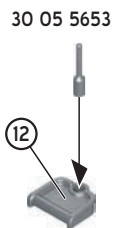

30 05 5653

30 08 4762



2x

30 05 5643

30 04 4262



30 63 6166



30 21 1383



30 63 6146

30 63 6246



30 05 5733

30 00 6164



30 25 3233

30 63 6336

30 00 6234



70459



70317

