



LEVEL 3
1 2 3 4 5



Grumman F-14D SUPER TOMCAT

Beiliegenden Sicherheitstext beachten / Please note the enclosed safety advice

- Ⓢ Beiliegenden Sicherheitstext beachten und nachschlagbereit halten.
- Ⓢ Please note the enclosed safety advice and keep safe for later reference.
- Ⓢ Respecter les consignes de sécurité ci-jointes et les conserver à portée de main.
- Ⓢ Houdt u aan de bijgaande veiligheidsinstructies en hou deze steeds bij de hand.
- Ⓢ Seguire le avvertenze di sicurezza allegate e tenerle a portata di mano.
- Ⓢ Observar y siempre tener a disposición este texto de seguridad adjunto.
- Ⓢ Ter em atenção o texto de segurança anexo e guardá-lo para consulta.

- Ⓢ Overhold vedlagte sikkerhedsanvisninger og hav dem liggende i nærheden.
- Ⓢ Ha alltid vedlagt sikkerhetstekst klar til bruk.
- Ⓢ Beakta bifogad säkerhetstext och håll den i beredskap.
- Ⓢ Huomioi ja säilytä oheiset varoitukset.
- Ⓢ Соблюдать технику безопасности, сохранить инструкцию для дальнейших обращений.
- Ⓢ Przestrzegać załączonego tekstu dotyczącego bezpieczeństwa i mieć go zawsze pod ręką.
- Ⓢ Dodržujte tento priložený bezpečnostní text a mějte ho po ruce.
- Ⓢ A mellékelt biztonsági szöveget vegye figyelembe és tartsa fellepozásra készen.

- Ⓢ Respektujte priložený bezpečnostný text a uchovajte ho pre budúce použitie.
- Ⓢ Respectați textul de siguranță atașat și păstrați-l la îndemână.
- Ⓢ Спазвайте приложения текст за безопасност и го дръжте под ръка за справки.
- Ⓢ Priložena varnostna navodila izvajajte in jih hranite na vsem dostopnem mestu.
- Ⓢ Λάβετε υπόψη σας το συννημένο κείμενο ασφαλείας και φυλάξτε το ώστε να ανατρέχετε σε αυτό όποτε χρειάζεται.
- Ⓢ Ektekiqüvenlik talimatlarını dikkate alıp, bakabileceğiniz bir şekilde muafaza ediniz.

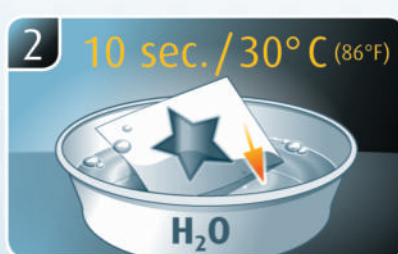
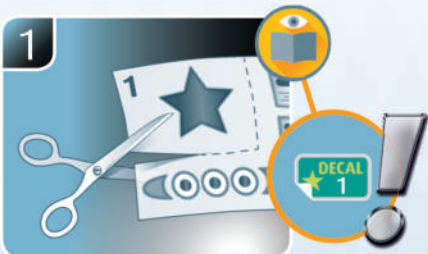
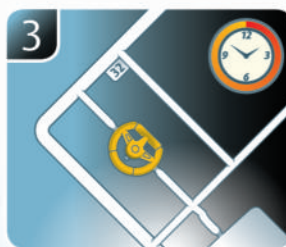
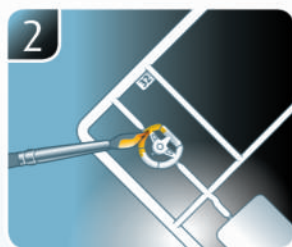
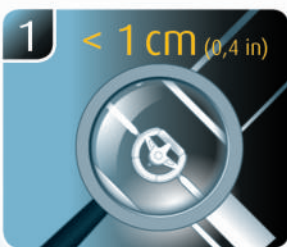
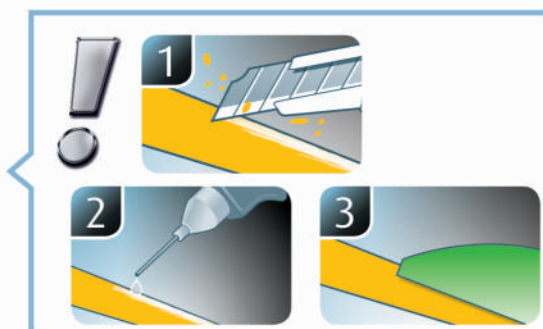
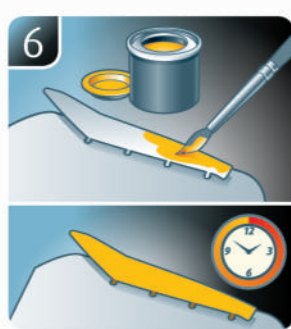
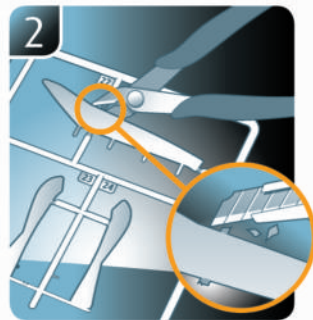
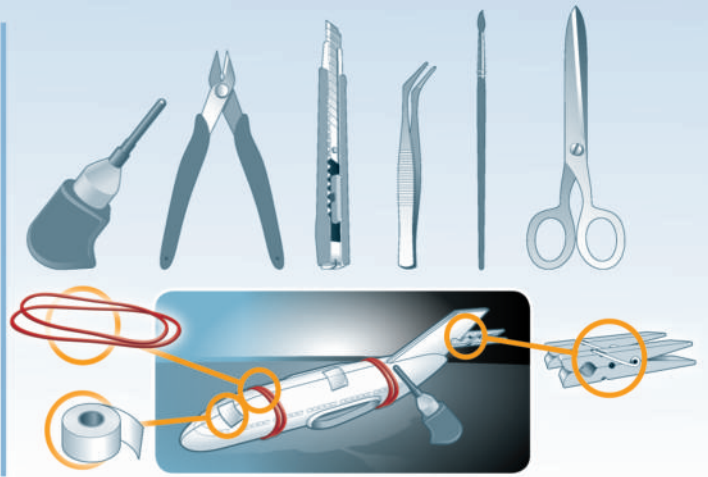

☞ Weitere Tipps und Tricks.
 ☞ Additional tips and tricks.
 ☞ Conseils et astuces supplémentaires.
 ☞ Andere tips en trucs.
 ☞ Ulteriori consigli e suggerimenti.
 ☞ Consejos y sugerencias adicionales.
 ☞ Mais dicas e truques.

☞ Flere tips og tricks.
 ☞ Flere tips og tricks.
 ☞ Ytterligare tips och tricks.
 ☞ Lisää vinkkejä ja niksejä.
 ☞ Другие советы и хитрости.
 ☞ Dalsze wskazówki i sugestie.
 ☞ Další tipy a rady.
 ☞ További ötletek és fogások.
 ☞ Dalsie tipy a triky.
 ☞ Alte sfaturi și trucuri.

☞ Други полезни съвети и трикове.
 ☞ Nadaljnji nasveti in zvižaje.
 ☞ Πρόσθετες συμβουλές και κόλπα.
 ☞ Diğer öneriler ve ipuçları.

www.revell.de



- DE Kleben
- EN glue
- FR Coller
- NL Lijmen
- IT Incollare
- ES Pegamento
- PT Colar
- DE Lim
- NO Lime
- SE Limma
- FI Liimaa
- RU Клеить
- PL Przykleić
- CZ Slepiti
- HU Ragasztás rá
- SK Lepiť
- RO Lipiți
- BG Залепете
- SI Prilepite
- GR Κολλήστε
- TR Yapıştırma



- DE Nicht kleben
- EN Don't glue
- FR Ne pas coller
- NL Niet lijmen
- IT Non incollare
- ES No pegamento
- PT Não colar
- DE Lim ikke
- NO Ikke lime
- SE Limma inte
- FI Älä liimaa
- RU Не клеить
- PL Nie przyklejać
- CZ Nelepiti
- HU Ne ragasztás rá
- SK Nelepiti
- RO Nu lipiți
- BG Не лепете
- SI Ne lepите
- GR Μη κολλήσετε
- TR Yapıştırmayın



- DE Bemalen
- EN Paint
- FR Peindre
- NL Beschilderen
- IT Colorare
- ES Pintar
- PT Pintar
- DE Mal
- NO Male
- SE Måla
- FI Maalaa
- RU Раскрасить
- PL Pomalować
- CZ Pomalovat
- HU Fesse be
- SK Natrief
- RO Vopsiți
- BG Боядисайте
- SI Robarvajte
- GR Βάψτε
- TR Boyama



- DE Anzahl der Arbeitsgänge.
- EN Number of working steps.
- FR Nombre d'étapes de travail.
- NL Het aantal bouwstappen.
- IT Numero di fasi di lavoro.
- ES Número de pasos de trabajo.
- PT Número de passos de trabalho.
- DE Antal arbejdsange.
- NO Antall arbeidstrinn.
- SE Antal operationer.
- FI Työvaiheiden määrä.
- RU Количество операций.
- PL Liczba cykli roboczych.
- CZ Počet pracovních kroků.
- HU A munkamenetek száma.
- SK Počet pracovných operácií.
- RO Numărul etapelor de lucru.
- BG Брой работни стъпки.
- SI Stevilo delovnih postopkov.
- GR Αριθμός βημάτων εργασίας.
- TR Çalışma adımı sayısı.



- DE Klarsichtteile
- EN Clear parts
- FR Pièces transparentes
- NL Transparente onderdelen
- IT Parti trasparenti
- ES Piezas transparentes
- PT Peças transparentes
- DE Klare dele
- NO Klare deler
- SE Genomskinliga detaljer
- FI Läpinäkyvät osat
- RU Прозрачные детали
- PL Przejrzyste części
- CZ Průhledné díly
- HU Átlátszó alkatrészek
- SK Číre diely
- RO Pieșe transparente
- BG Прозрачни части
- SI Prozorni deli
- GR Διάφανάμέρη
- TR Şeffaf parçalar



- DE Mit einem Messer abtrennen.
- EN Detach with knife.
- FR Détacher au couteau.
- NL Met een mesje afsnijden.
- IT Separare con un coltello.
- ES Separar con cuchillo.
- PT Separar com uma faca.
- DE Skær af med en kniv.
- NO Separer med kniv.
- SE Skall skiljas av med en kniv.
- FI Erotta veitsellä.
- RU Отделить ножом.
- PL Oddzielić za pomocą noża.
- CZ Oddělte nožem.
- HU Válassza le a késsel.
- SK Oddelte nožom.
- RO Desprindeți cu un cuțit.
- BG Откъснете с нож.
- SI Odrežite z ustreznim rezilom.
- GR Αφαιρέστε με ένα μαχαίρι.
- TR Bir bıçak ile kesin.



- DE Entfernen
- EN Remove
- FR Détacher
- NL Verwijderen
- IT Rimuovere
- ES Eliminar
- PT Remover
- DE fjern
- NO fjerne
- SE Ta bort
- FI Poistaa
- RU Удалить
- PL Usunąć
- CZ Odstranit
- HU Eltávolítani
- SK Odstráňte
- RO Îndepărtați
- BG Отстранете
- SI Odstranitev
- GR Αφαιρέστε
- TR Çıkar



- DE Wahlweise
- EN Optional
- FR Facultatif
- NL Naar keuze
- IT Facoltativamente
- ES Opcional
- PT Opcional
- DE Valgfri
- NO Valgfritt
- SE Valfri
- FI Valinnaisesti
- RU На выбор
- PL Opcjonalnie
- CZ Volitelně
- HU Választás szerint
- SK Alternatívne
- RO Opțional
- BG По избор
- SI Izbirno
- GR Προαιρετικά
- TR Opsiyonel



- DE Abbildung zusammengesetzter Teile.
- EN Illustration of assembled parts.
- FR Figure représentant les pièces assemblées.
- NL Afbeelding van samengevoegde onderdelen.
- IT Foto delle parti assemblate.
- ES Figura de las piezas montadas.
- PT Ilustração das peças montadas.
- DE Illustration af samlede dele.
- NO Figur av sammensatte deler.
- SE Bild på sammansatta detaljer.
- FI Koottujen osien kuva.
- RU Изображение смонтированных деталей.
- PL Rysunek połączonych części.
- CZ Zobrazení spojených dílů.
- HU Összerakott alkatrészek ábrája.
- SK Obrázok dielov, ktoré sa majú zmontovať.
- RO Figura reprezentând piesele asamblate.
- BG Изображение на сглобените части.
- SI Slika sestavljenih delov.
- GR Απεικόνιση των τοποθετημένων μερών.
- TR Birleştirilmiş parçaların resmi.



- DE Loch bohren.
- EN Make a hole.
- FR Faire un trou.
- NL Maak een gat.
- IT Praticare un foro.
- ES Hacer un agujero.
- PT Fazer um furo.
- DE Fazer um furo.
- NO Lav et hul.
- RO Bor et hull.
- SE Borra hål.
- FI Poraa reikä.
- RU Просверлить отверстие.
- PL Wywiercić otwór.
- CZ Vyvrtejte otvor.
- HU Fúrjon lyukat.
- SK Vyvrtajte otvor.
- RO Faceti o gaură.
- BG Пробийте дупка.
- SI Izvrtajte izvrtino.
- GR Ανοίξτε τρύπα.
- TR Delik açın.



- DE Bauteile trocknen lassen.
- EN Allow the parts to dry.
- FR Laisser sécher les pièces.
- NL Onderdelen laten drogen.
- IT Lasciare asciugare i componenti.
- ES Dejar secar las piezas.
- PT Deixar as peças secar.
- DE Lad delene tørre.
- NO Tørk komponenter.
- SE Låt komponenterna torka.
- FI Anna rakenneseosien kuivua.
- RU Дайте деталям высохнуть.
- PL Pozostawić elementy konstrukcji do wyschnięcia.
- CZ Nechte díly uschnout.
- HU Hagyja megszáradni az alkatrészeket.
- SK Konštrukčné diely nechajte vyschnúť.
- RO Lăsați componentele să se usuce.
- BG Оставете сглобените части да изсъхнат.
- SI Osušite sestavne dele.
- GR Αφήστε τα μέρη να στεγνώσουν.
- TR Yapı parçalarını kurumaya bırakın.



- DE Mit Klebeband fixieren.
- EN Attach with adhesive tape.
- FR Fixer à l'aide de ruban adhésif.
- NL Met plakband vastzetten.
- IT Fissare con nastro adesivo.
- ES Fijar con cinta adhesiva.
- PT Fixar com fita adesiva.
- DE Fastgør med tape.
- NO Fest med tape.
- SE Fixera med tejp.
- FI Kiinnittää liimanauhalla.
- RU Зафиксировать липкой лентой.
- PL Przykleić taśmą samoprzylepną.
- CZ Připevněte lepicí páskou.
- HU Rögzítse ragasztószalaggal.
- SK Fixujte lepiacou páskou.
- RO Fixați cu bandă adezivă.
- BG Фиксирайте с тиксо.
- SI Pripržite z lepilnim trakom.
- GR Στερεώστε με κολλητική ταινία.
- TR Yapıştırma bandı ile sabitleyin.



- DE Abziehbild in Wasser einweichen und anbringen.
- EN Soak and apply decals.
- FR Mouiller et appliquer les décalcomanies.
- NL Transfer in water even laten weken en aanbrengen.
- IT Immergere la decalcomania nell'acqua e applicarla.
- ES Mojar y aplicar calcomanías.
- PT Amolecer o decalque em água e aplicar.
- DE Gør overføringsbilledet vådt og sæt det på.
- NO Myk opp avtrekingsbildet i vann og sett på.
- SE Blötlägg dekalen i vatten och sätt på den.
- FI Pehmitä siirtokuva vedessä ja siirtä paikalleen.
- RU Опустите переводную картинку в воду и нанесите её.
- PL Namoczyć kalkomanie w wodzie i przykleić.
- CZ Nechte obtisk odmočit ve vodě a přilepte.
- HU Merítse vízbe és helyezze fel a matricát.
- SK Otbláčkový obrázok namočte do vody a priložte na plochu.
- RO Înmuiați abțibildul în apă și aplicați-l.
- BG Потопете ваденката във вода и я поставете.
- SI Prelepnicó namakajte v vodi. In namestito.
- GR Μουσκεύετε σε νερό και τοποθετήστε τις χαλκομανίες.
- TR Çikartmayı suda yumuşatın ve takın.



- DE Bauanleitung sorgfältig lesen.
- EN Read the assembly instructions carefully.
- FR Lisez attentivement les instructions de montage.
- NL Bouwinstructies zorgvuldig doorlezen.
- IT Leggere attentamente le istruzioni per il montaggio.
- ES Lea cuidadosamente las instrucciones de montaje.
- PT Ler atentamente as instruções de montagem.
- DE Læs byggevejledningen omhyggeligt.
- NO Les byggeanvisningen nøye.
- SE Monteringsinstruktionerna skall läsas noggrant.
- FI Lue kokoamisohje huolellisesti.
- RU Внимательно прочитайте инструкцию по сборке.
- PL Dokładnie przeczytaj instrukcję montażu.
- CZ Přečtěte si pečlivě návod k obsluze.
- HU Figyelemesen olvassa el a szerelési útmutatót.
- SK Návod na montáž starostlivo prečítajte.
- RO Cititi cu atenție instrucțiunile de montare.
- BG Прочетете внимателно уътването за монтаж.
- SI Skrbno preberite navodila za sestavo.
- GR Διαβάστε προσεκτικά τις οδηγίες κατασκευής.
- TR Yapı kılavuzunu dikkatle okuyun.



- DE Zur Anbringung der Abziehbilder empfohlen.
- EN Recommended for affixing the decals.
- FR Recommandé pour l'application des décalcomanies.
- NL Aanbevolen voor het aanbrengen van de transfers.
- IT Raccomandato per l'applicazione delle decalcomanie.
- ES Recomendado para fijar bien las calcomanías.
- PT Recomendado para a fixação dos autocolantes.
- DE Anbefales til anbringelse af overføringsbillederne.
- NO Anbefales til å feste avtrekksbilder.
- SE Rekommenderad för montering av klisterdekalerna.
- FI Suositellaan siirtokuvien siirtämiseen.
- RU Рекомендуются для нанесения переводных картинок.
- PL Zalecane do przyklejenia kalkomanii.
- CZ Doporučujeme k umístění obtiskovacích obrázků.
- HU A matrica felhelyezéséhez ajánlható.
- SK Odporúčajú sa pre umiestnenie otbláčkových obrázkov.
- RO Recomandat pentru aplicarea pieselor transparente.
- BG Препоръчва се за поставяне на ваденки.
- SI Pri nameščanju nalepnic priporočamo.
- GR Συνιστάται για την τοποθέτηση των διαφανών μερών.
- TR Çikartmaların takılması için önerilir.



- DE Zur Anbringung der Klarteile empfohlen.
- EN Recommended to fix clear parts.
- FR Recommandé pour fixer les pièces transparentes.
- NL Aanbevolen voor het aanbrengen van transparante delen.
- IT Raccomandato per l'applicazione delle parti trasparenti.
- ES Recomendado para fijar las piezas transparentes.
- PT Recomendado para a aplicação das peças transparentes.
- DE Anbefales til anbringelse af de klare dele.
- NO Anbefales til å feste klare deler.
- SE Rekommenderad för montering av de genomskinliga detaljerna.
- FI Suositellaan läpinäkyvien osien siirtämiseen.
- RU Рекомендуются для крепления прозрачных деталей.
- PL Zalecane do przyklejenia przezroczystych części.
- CZ Doporučujeme k umístění průhledných dílů.
- HU Az átlátszó darabok felhelyezéséhez ajánlható.
- SK Odporúčajú sa pre umiestnenie čírych dielov.
- RO Recomandat pentru aplicarea pieselor transparente.
- BG Препоръчва се за поставяне на прозрачни части.
- SI Pri nameščanju prozornih delov priporočamo.
- GR Συνιστάται για την τοποθέτηση των διάφανων μερών.
- TR Şeffaf parçaların takılması için önerilir.

- * DE Nicht enthalten
- EN Not included
- FR Non fourni
- NL Behoort niet tot de levering
- IT Non incluso
- ES No incluido
- PT Não incluído
- DE Medfølger ikke
- NO Ikke inkludert
- SE Ingår ej
- FI Ei sisällä
- RU Не содержится
- PL Nie wchodzi w zakres dostawy
- CZ Není obsaženo
- HU Nem tartalmazza
- SK Neobsahuje
- RO Nu este inclus
- BG Не се включва в комплекта
- SI Ni priloženo
- GR Δεν περιλαμβάνεται
- TR İçermiyor

Benötigte Farben / Required colours

FR Peintures nécessaires
NL Benodigde kleuren
IT Colori necessari
ES Colores necesarios
PT Cores necessárias
DK Nødvendige farver
NO Nødvendige farger
SE Erforderliga färger
FI Tarvittavat värit
RU Необходимые краски
PL Potrzebne kolory
CZ Potřebné barvy
HU Szükséges színek
SK Požadované farby
RO Culori necesare
BG Необходими цветове
SI Potrebne barve
GR Απαιτούμενα χρώματα
TR Gerekli renkler

08

A

DE Schwarz matt
GB Black matt
FR Noir mat
NL Zwart mat
IT Nero opaco
ES Negro mate
PT Preto mate
DK Sort mat
NO Sort matt
SE Svart matt
FI Musta matta
RU Чёрный матовый
PL Czarny matowy
CZ Černá matný
HU Fekete, fénytelen
SK Čierna matný
RO Negru mat
BG Черно матово
SI Črna mat
GR Μαύρο ματ
TR Siyah mat

57

B

DE Grau matt
GB Grey matt
FR Gris mat
NL Grijs mat
IT Grigio opaco
ES Gris mate
PT Cinzento mate
DK Grå mat
NO Grå matt
SE Grå matt
FI Harmaa matta
RU Серый матовый
PL Szary matowy
CZ Šedá matný
HU Szürke, fénytelen
SK Sivá matný
RO Gri mat
BG Сиво матово
SI Siva mat
GR Γκρι ματ
TR Gri mat

79

C

DE Blaugrau matt
GB Blue-grey matt
FR Gris bleu mat
NL Blauwgrijs mat
IT Grigio bluastrò opaco
ES Azul grisáceo mate
PT Azul acinzentado mate
DK Blågrøn mat
NO Gråblå matt
SE Blågrøn matt
FI Harmaansininen matta
RU Серо-синий матовый
PL Niebieskoszary matowy
CZ Šedomodrá matný
HU Kékesszürke, fénytelen
SK Sivomodrá matný
RO Albastru cenușiu mat
BG Синьо-сиво матово
SI Modro-siva mat
GR Γκρι-μπλε ματ
TR Gri mavi mat

91

D

DE Eisen metallic
GB Iron metallic
FR Fer métallique
NL IJzer metallic
IT Ferro metallico
ES Acero metálico
PT Aço metálico
DK Stål metallisk
NO Jern metallic
SE Stål metallic
FI Teräs metallinen
RU Сталь металл
PL Grafit metaliczny
CZ Ocelová metalizovaný
HU Acélmetál
SK Ocelová metaliza
RO Fier metalic
BG Желязо металик
SI Železna kovinska
GR Χρώμα σιδήρου μεταλλικό
TR Metalik metalik

99

F

DE Aluminium metallic
GB Aluminium metallic
FR Aluminium métallique
NL Aluminium metallic
IT Alluminio metallico
ES Aluminio metálico
PT Alumínio metálico
DK Aluminium metallisk
NO Aluminium metallic
SE Aluminium metallic
FI Alumiini metallinen
RU Аллюминий металл
PL Aluminium metaliczny
CZ Hliníková metalizovaný
HU Alumínium metál
SK Hliníková metaliza
RO Aluminiu metalic
BG Алюминий металик
SI Aluminijasta kovinska
GR Αλουμίνιο μεταλλικό
TR Alüminyum grisi metalik

05

G

DE Weiß matt
GB White matt
FR Blanc mat
NL Wit mat
IT Bianco opaco
ES Blanco mate
PT Branco mate
DK Hvid mat
NO Hvit matt
SE Vit matt
FI Valkoinen matta
RU Белый матовый
PL Biały matowy
CZ Bílá matný
HU Fehér, fénytelen
SK Biela matný
RO Alb mat
BG Бяло матово
SI Bela mat
GR Ασπρο ματ
TR Beyaz mat

36

H

DE Karminrot matt
GB Carmine red matt
FR Rouge carmin mat
NL Karmijnrood mat
IT Rosso carminio opaco
ES Rojo carmin mate
PT Vermelho carmim mate
DK Karminrød mat
NO Karminrød matt
SE Karminrød matt
FI Karmininpunainen matta
RU Карминный матовый
PL Karminowa czerwien matowy
CZ Karminová červená matný
HU Karminpiros, fénytelen
SK Karminovo červená matný
RO Roșu-carmin mat
BG Карминовочервено матово
SI Karminsko-rdeča mat
GR Άλικο κόκκινο ματ
TR Karmen kırmizisi mat

09

I

DE Anthrazit matt
GB Anthracite matt
FR Anthracite mat
NL Antraciet mat
IT Antracite opaco
ES Antracita mate
PT Antracite mate
DK Antracitgrå mat
NO Antrasitt matt
SE Antracitgrå matt
FI Antrasitiinharmaa matta
RU Антрацит матовый
PL Antracyt matowy
CZ Antracitová šedá matný
HU Antracit, fénytelen
SK Čierna uhľová matný
RO Antracit mat
BG Антрацит матово
SI Antracit mat
GR Γκρι ανθρακι ματ
TR Anthrazit mat

76

K

DE Hellgrau matt
GB Light grey matt
FR Gris clair mat
NL Lichtgrijs mat
IT Grigio chiaro opaco
ES Gris claro mate
PT Cinza claro mate
DK Lysegrå mat
NO Lysegrå matt
SE Ljusgrå matt
FI Vaaleanharmaa matta
RU Светло-серый матовый
PL Jasnoszary matowy
CZ Světlá šedivá matný
HU Világosszürke, fénytelen
SK Svetlo sivá matný
RO Gri-deschis mat
BG Светлосиво матово
SI Svetlo-siva mat
GR Γκρι ανοιχτό ματ
TR Açık gri mat

65

L

DE Bronzegrün matt
GB Bronze green matt
FR Vert bronze mat
NL Bronsgroen mat
IT Verde bronzo opaco
ES Verde bronce mate
PT Verde bronze mate
DK Bronzegrøn mat
NO Bronsegrønn matt
SE Bronsgrøn matt
FI Pronssinvihreä matta
RU Бронзово-зелёный матовый
PL Brązowozielony matowy
CZ Bronzová zelená matný
HU Bronz zöld, fénytelen
SK Bronzovo zelená matný
RO Verde-bronz mat
BG Бронзовозелено матово
SI Bronasto-zelena mat
GR Λαδί ματ
TR Bakır yeşili mat

15

N

DE Gelb matt
GB Yellow matt
FR Jaune mat
NL Geel mat
IT Giallo opaco
ES Amarillo mate
PT Amarelo mate
DK Gul mat
NO Gul matt
SE Gul matt
FI Keltainen matta
RU Жёлтый матовый
PL Żółty matowy
CZ Žlutá matný
HU Sárga, fénytelen
SK Žltá matný
RO Galben mat
BG Жълто матово
SI Rumena mat
GR Κίτρινο ματ
TR Sarı mat

16

O

DE Sand matt
GB Sand matt
FR Sable mat
NL Zandkleur mat
IT Sabbia opaco
ES Arena mate
PT Areia mate
DK Sand mat
NO Sand matt
SE Sandgul matt
FI Hiekankeltainen matta
RU Песочный матовый
PL Piaskowożółty matowy
CZ Písková žlutá matný
HU Homokszínű, fénytelen
SK Piesková žltá matný
RO Galben-nisip mat
BG Пясъчно матово
SI Peščena mat
GR Μουσαρόδι ματ
TR Kum sarısı mat

371

P

DE Hellgrau seidenmatt
GB Light grey silk matt
FR Gris clair satiné mat
NL Lichtgrijs zijdemat
IT Grigio chiaro opaco satinato
ES Gris claro mate satinado
PT Cinza claro mate sedoso
DK Lysegrå silkematt
NO Lysgrå silkematt
SE Ljusgrå sidenmatt
FI Vaaleanharmaa silkimatta
RU Светло-серый шелковисто-матовый
PL Jasnoszary jedwabiscie matowy
CZ Světlá šedá jemně matný
HU Világosszürke, fakóselymes
SK Svetlo sivá hodvábné matný
RO Gri-deschis satinat
BG Светлосиво коприненоматово
SI Svetlo-siva svileni-mat
GR Γκρι ανοιχτό σατινέ
TR Açık gri ipeksi mat

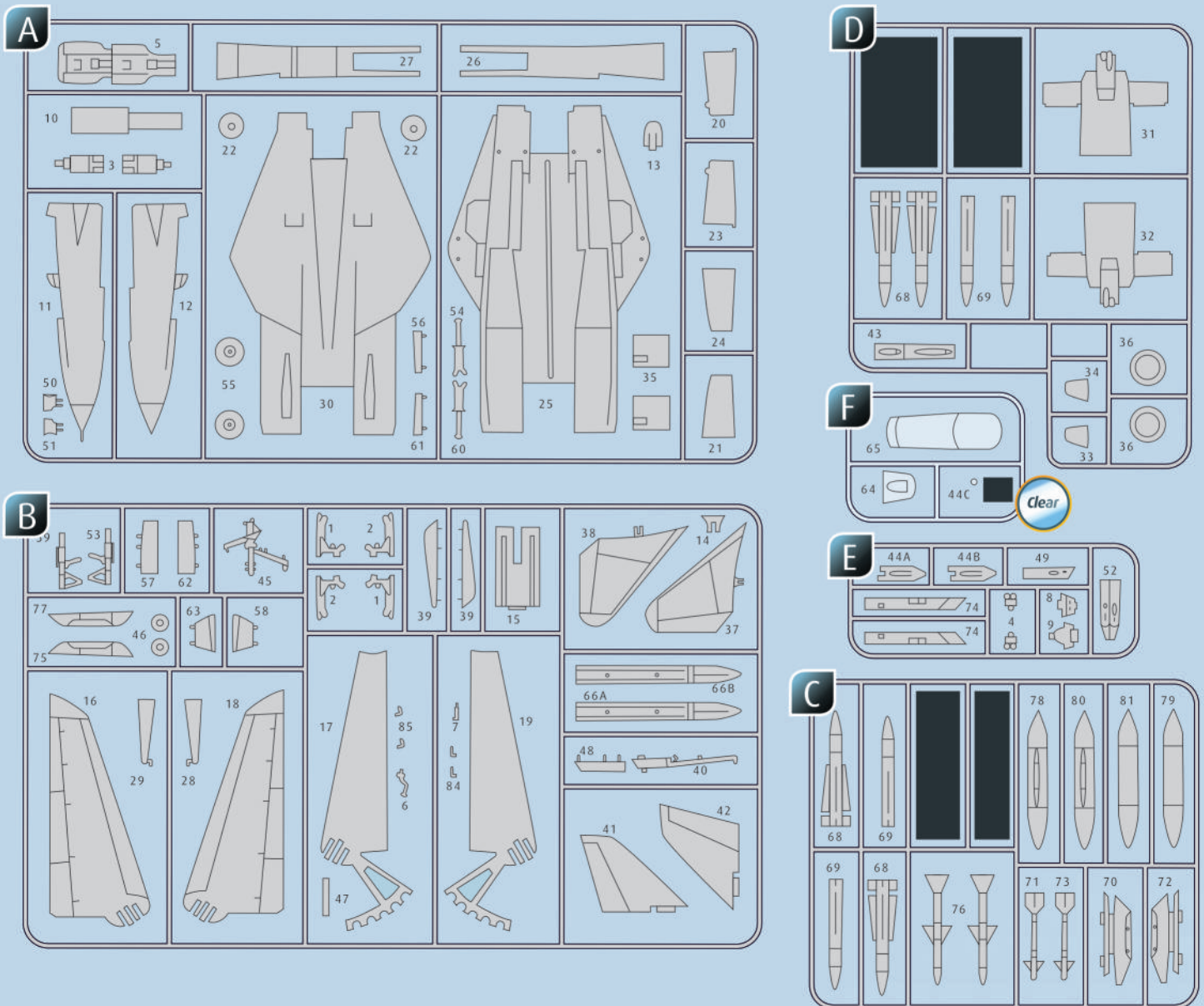

(DE) Nicht benötigte Teile
 (EN) Parts not used.
 (FR) Pièces non utilisées.
 (NL) Niet benodigde onderdelen.
 (IT) Parti non necessarie.
 (ES) Piezas no utilizadas.
 (PT) Peças não utilizadas.

(DK) Dele der ikke skal bruges.
 (NO) Deler som ikke er nødvendige.
 (SE) Ej nödvändiga delar.
 (FI) Tarpeettomat osat.
 (RU) Неиспользуемые детали.
 (PL) Niepotrzebne części.
 (CZ) Nepotřebné díly.

(HU) Szükségtelen alkatrészek.
 (SK) Nepotrebné diely.
 (RO) Piese care nu sunt necesare.
 (BG) Ненужни детайли.
 (SI) Nepotrebni deli.
 (GR) Μη χρησιμοποιούμενα μέρη.
 (TR) Gereklı olmayan parçalar.

Ersatzteile benötigt?

Kein Problem. Einfach den Revell-Service mit Angabe von Artikel- und Teilenummer kontaktieren. Entweder unter service@revell.de oder Revell GmbH, Abteilung X, Henschelstr. 20-30, 32257 Bünde.*

*Wir bitten um Verständnis, dass eine Gewährleistung nur bei aktuellen Artikeln, die im Zeitraum der letzten 24 Monate erworben wurden, übernommen werden kann. Mit der Ersatzteil-Bestellung können Kosten z.B. für Verpackung und Versand entstehen. Ob diese Kosten anfallen wird im Vorfeld schriftlich durch unseren Service mitgeteilt. Das Angebot kann dann angenommen oder abgelehnt werden. Unfrei eingesandte Ersatzteil-Bestellungen werden von uns nicht angenommen! Dieser Direktservice gilt für die Länder Deutschland, Benelux, Österreich, Frankreich, Großbritannien. Ersatzteil-Bestellungen aus den übrigen Ländern werden über die jeweiligen Distributeure abgewickelt. Bitte kontaktieren Sie Ihren Händler.

Besoin de pièces de rechange ?

Il vous suffit de contacter le service Revell et d'indiquer la référence de l'article et de la pièce. Soit en écrivant par mail à france@revell.de (uniquement pour la France) ou par courrier à Revell GmbH, Département X, Henschelstr. 20-30, D-32257 Bünde.*

*La garantie s'applique pour les articles présents au catalogue et achetés au cours des 24 derniers mois. Merci de votre compréhension. La commande de pièces de rechange peut donner lieu à des frais supplémentaires, par ex. pour l'emballage et le port. Notre service client vous en informera au préalable par écrit. Vous pourrez accepter ou refuser le devis. Nous n'acceptons pas les commandes de pièces de rechange envoyées sans affranchissement ! Ce service direct est valable pour les pays suivants : Allemagne, Benelux, Autriche, France, Grande-Bretagne. Les commandes de pièces en provenance d'autres pays sont traitées par les distributeurs correspondants. Veuillez contacter votre revendeur.

Need spare parts?

No problem. Contact Revell Service with the item number and part numbers you need: service@revell.de or Revell GmbH, Unit 10, Old Airfield Industrial Estate, Cheddington Lane, Tring, Herts, HP23 4QR, Great Britain.*

*We request your understanding that a warranty can only be accepted for current articles which have been purchased in the last 24 months. Orders for spare parts may also be subject to costs for packaging and shipping. You will be notified in advance by our Service department if such costs are incurred. The offer can then be accepted or rejected. We will not be able to process any postal requests unless correct postage has been applied to mailing! This direct service applies to the countries: Germany, Benelux, Austria, France, and the United Kingdom. Spare part orders from other countries are processed by the local distributors. Please contact your dealer.

Hebt u reserveonderdelen nodig?

Geen probleem! Neem eenvoudig contact op met de klantenservice van Revell en geef ons het artikel- en onderdeelnummer door. U kunt ons bereiken op service@revell.de of per post: Revell GmbH, Afdeling X, Henschelstr. 20-30, 32257 Bünde.*

*Wij vragen uw begrip voor de omstandigheid, dat er alleen garantie kan worden geboden voor actuele artikelen, die in de afgelopen 24 maanden zijn gekocht. Met het bestellen van reserveonderdelen kunnen kosten gemoeid zijn, bijv. voor verpakking en verzending. U wordt vooraf schriftelijk door onze klantenservice op de hoogte gesteld als er kosten zouden ontstaan. Het aanbod kan dan worden aangenomen of afgewezen. Wij nemen geen ongefrankeerde bestellingen van reserveonderdelen aan! Deze rechtstreekse service wordt verleend in de landen Duitsland, de Benelux, Oostenrijk, Frankrijk en Groot-Brittannië. Bestellingen van reserveonderdelen in de overige landen worden afgewikkeld via de betreffende distributeurs. Neem hiervoor contact op met uw verkoper.

1 

 → 45

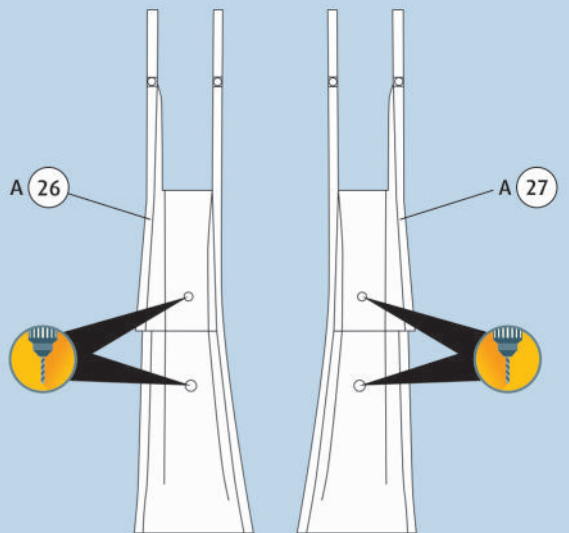
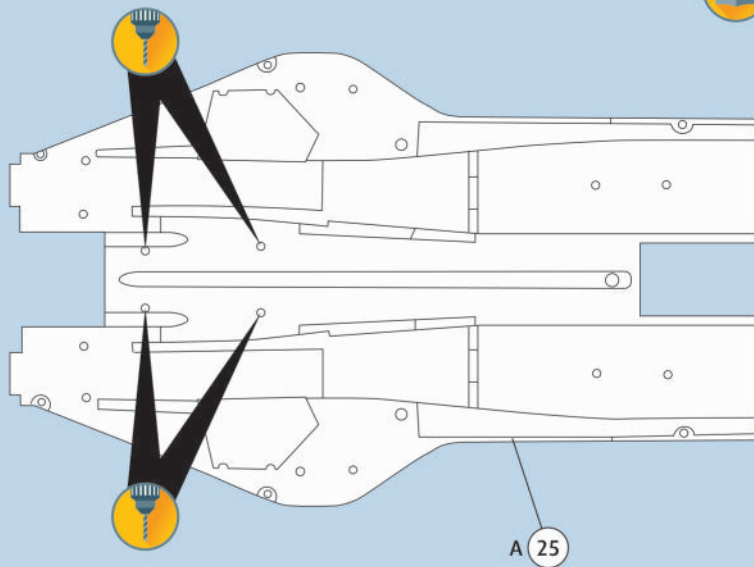

2   2X

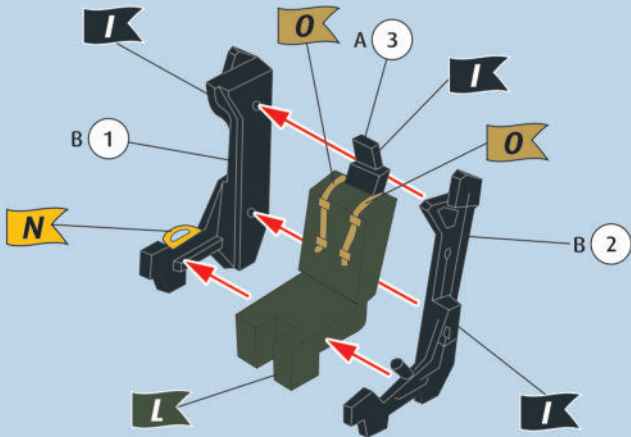

3   2X

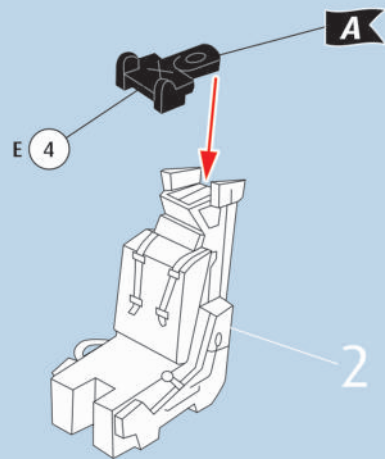

4  

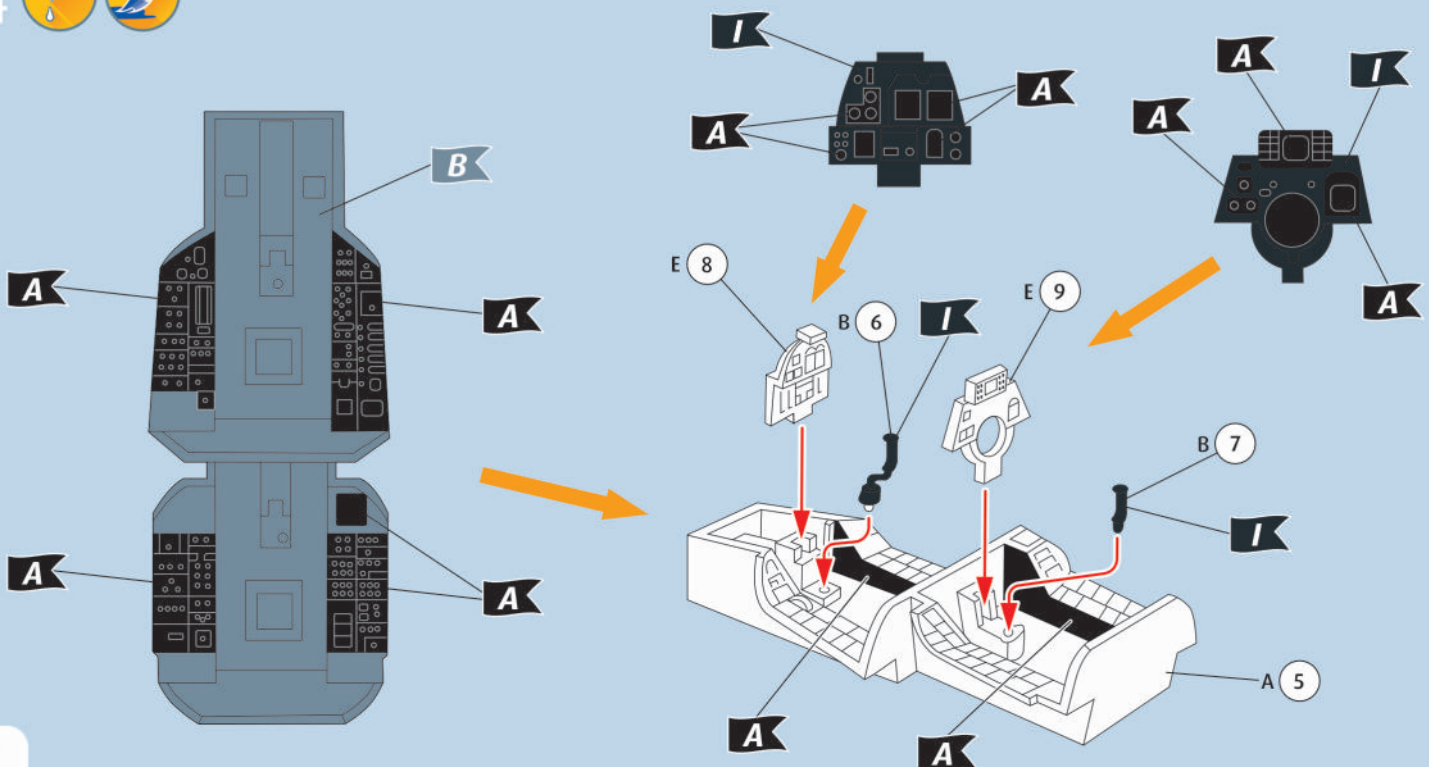

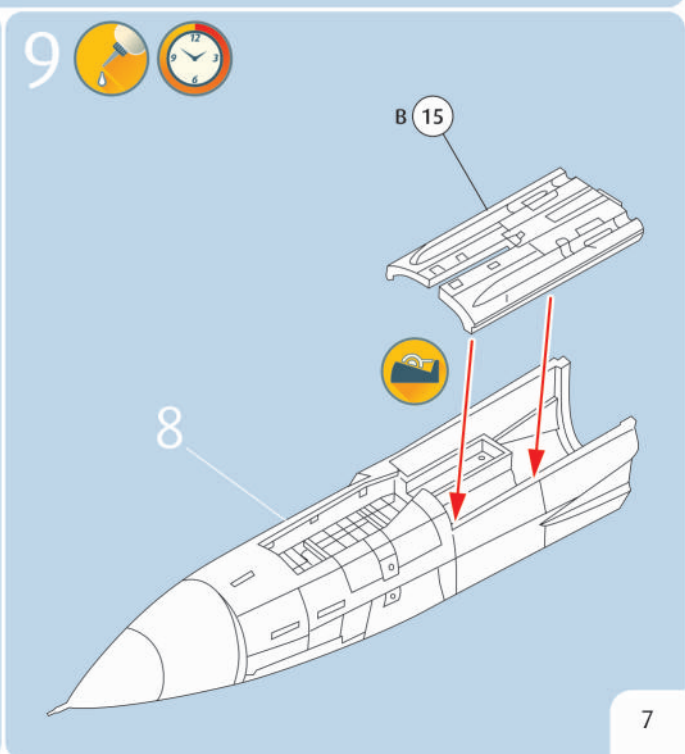
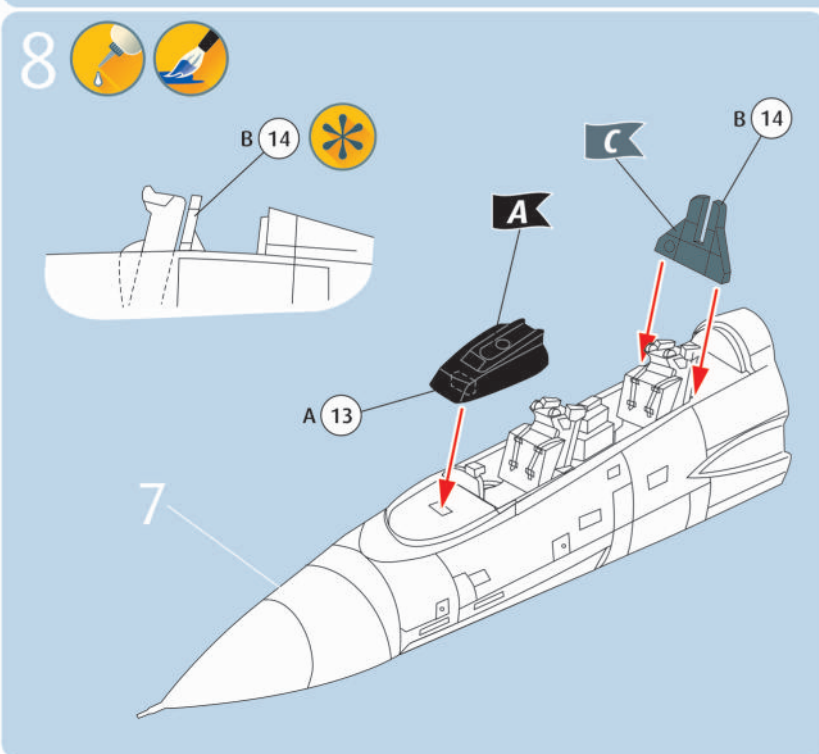
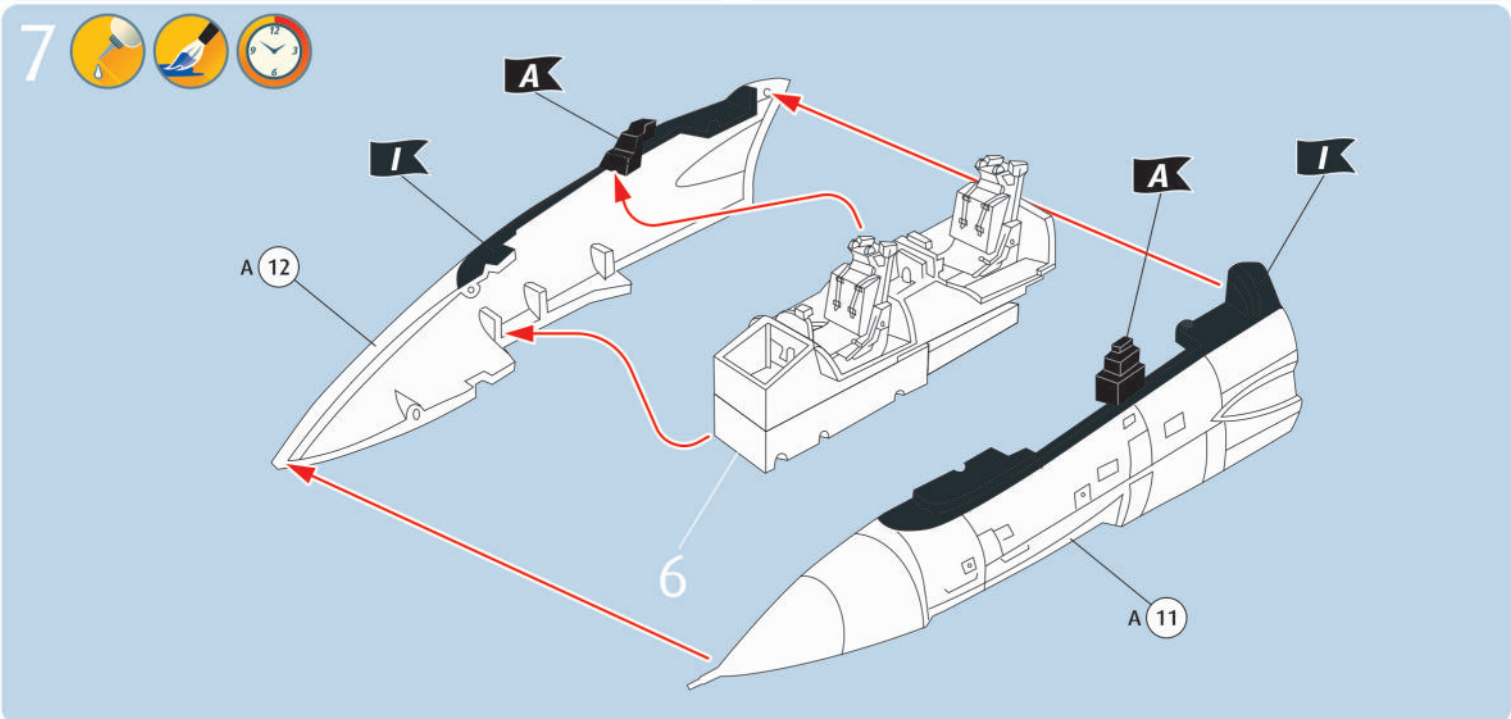
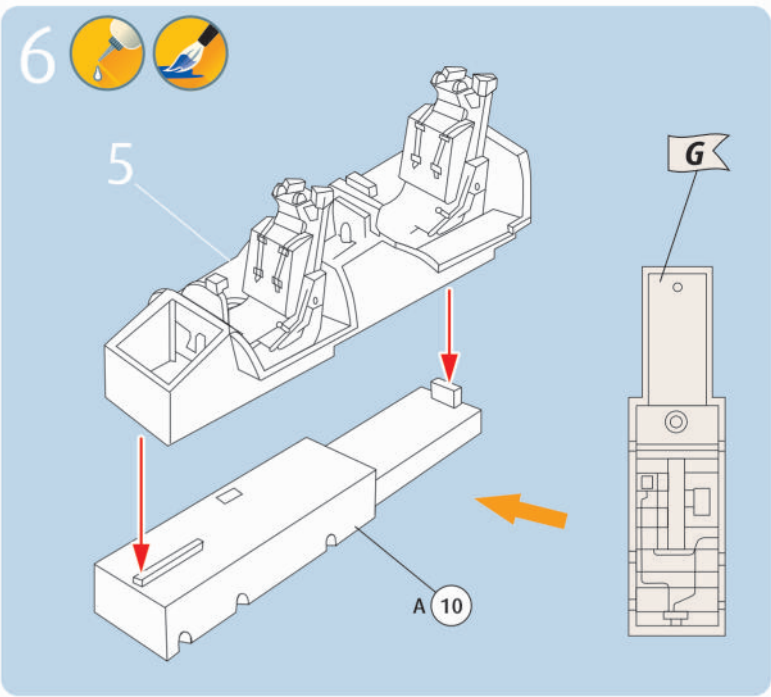
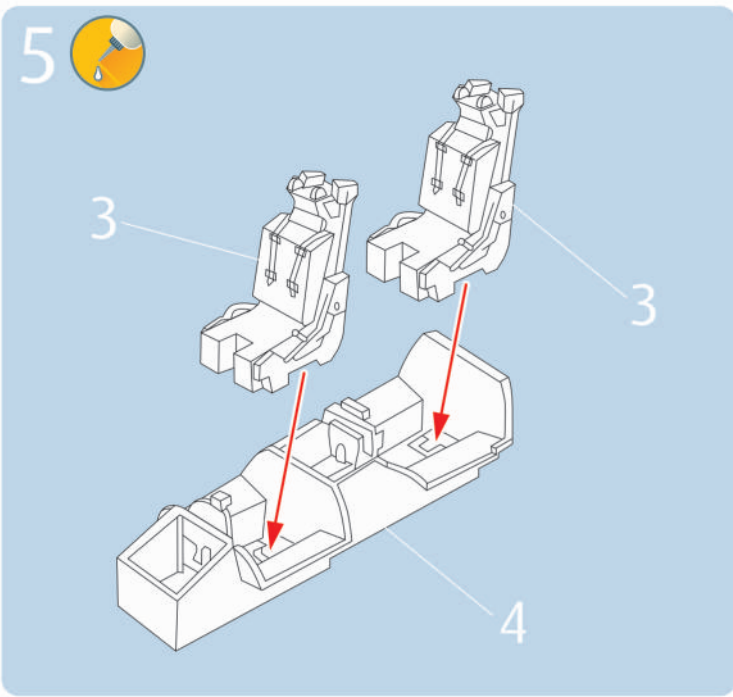

10  

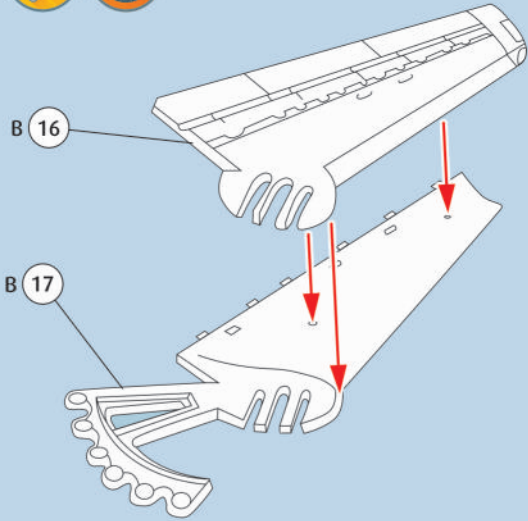

11  

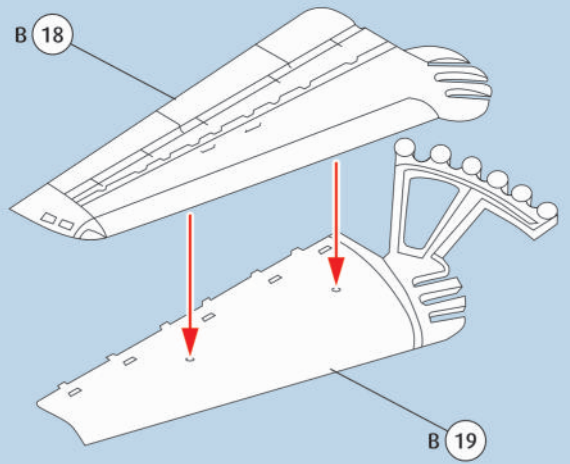

12  

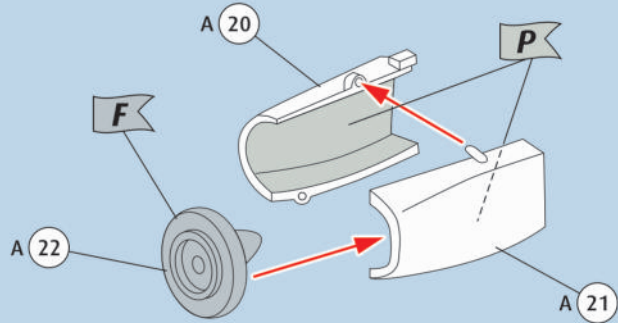

13  

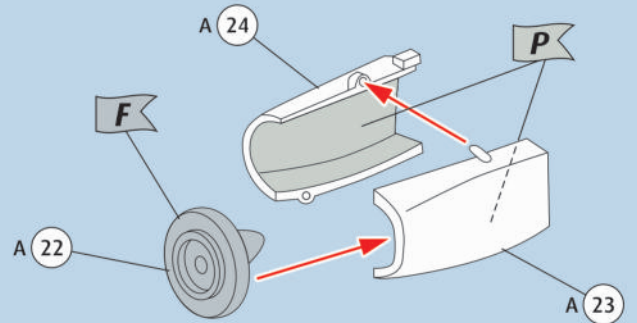

14 

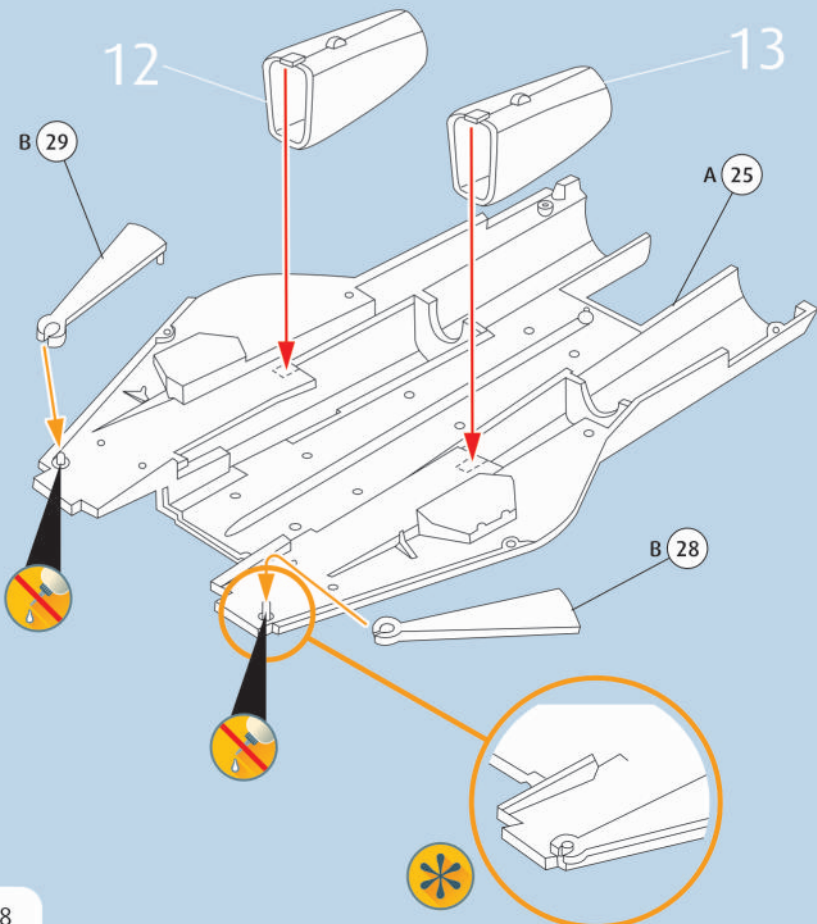

15   

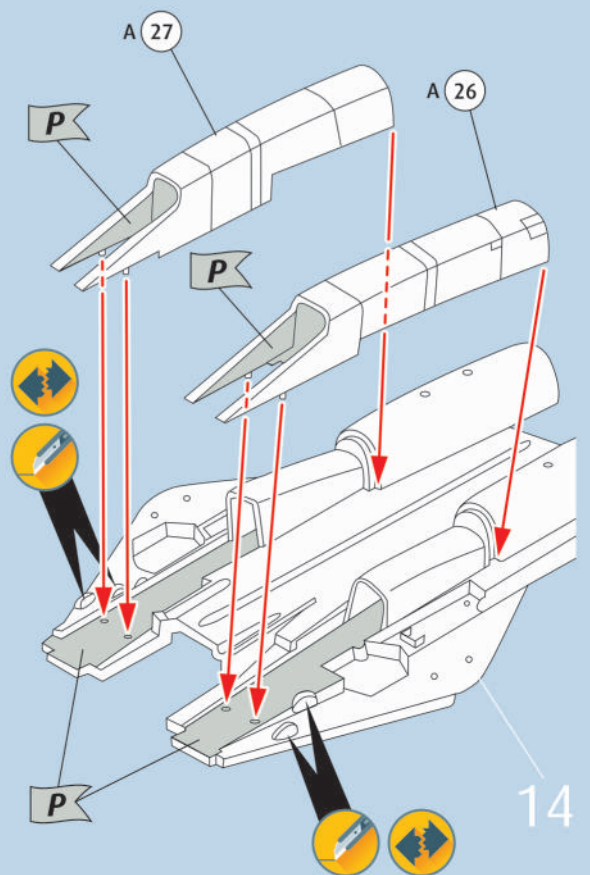

16

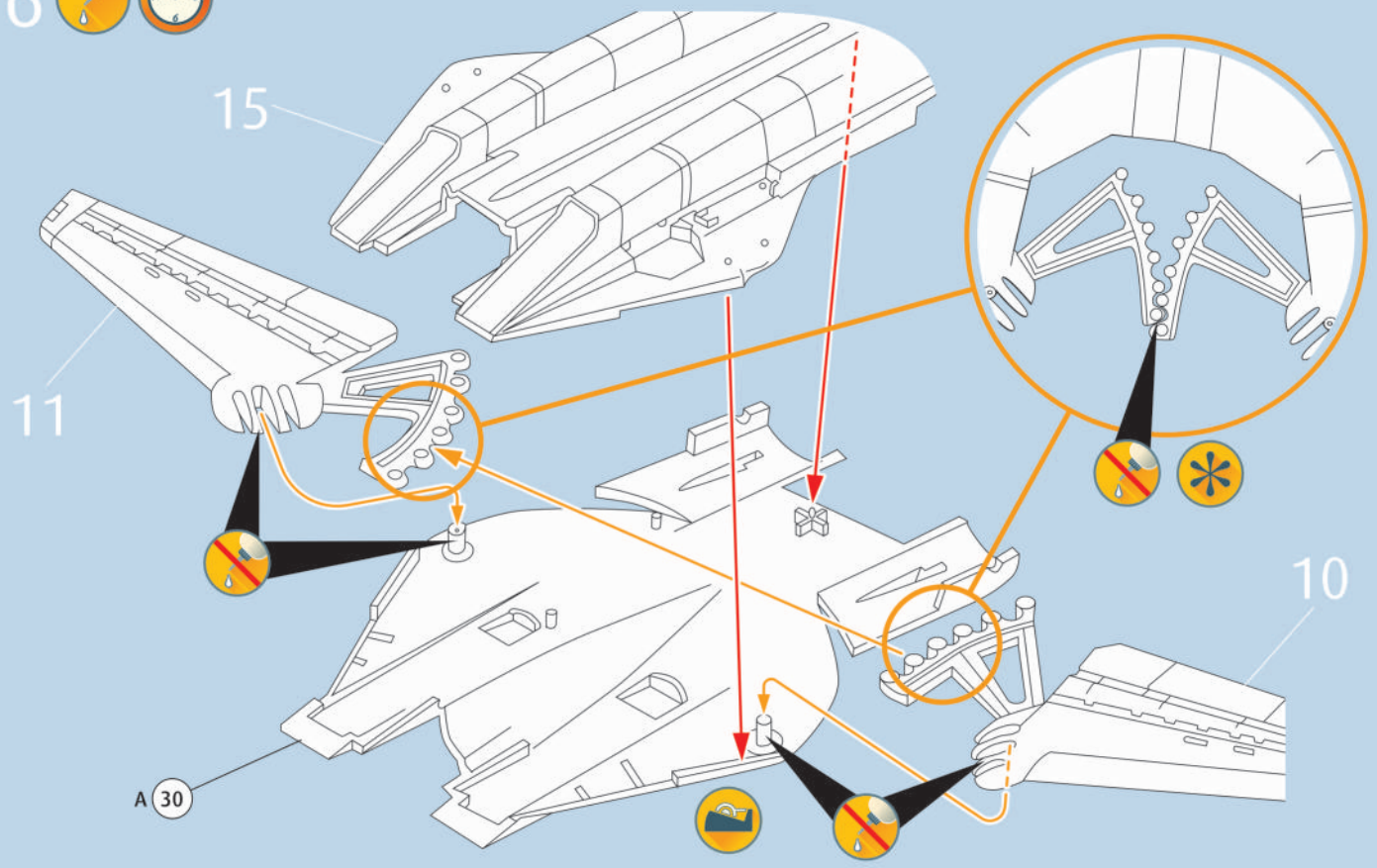

17

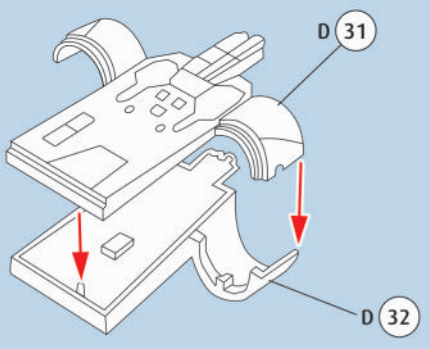

18

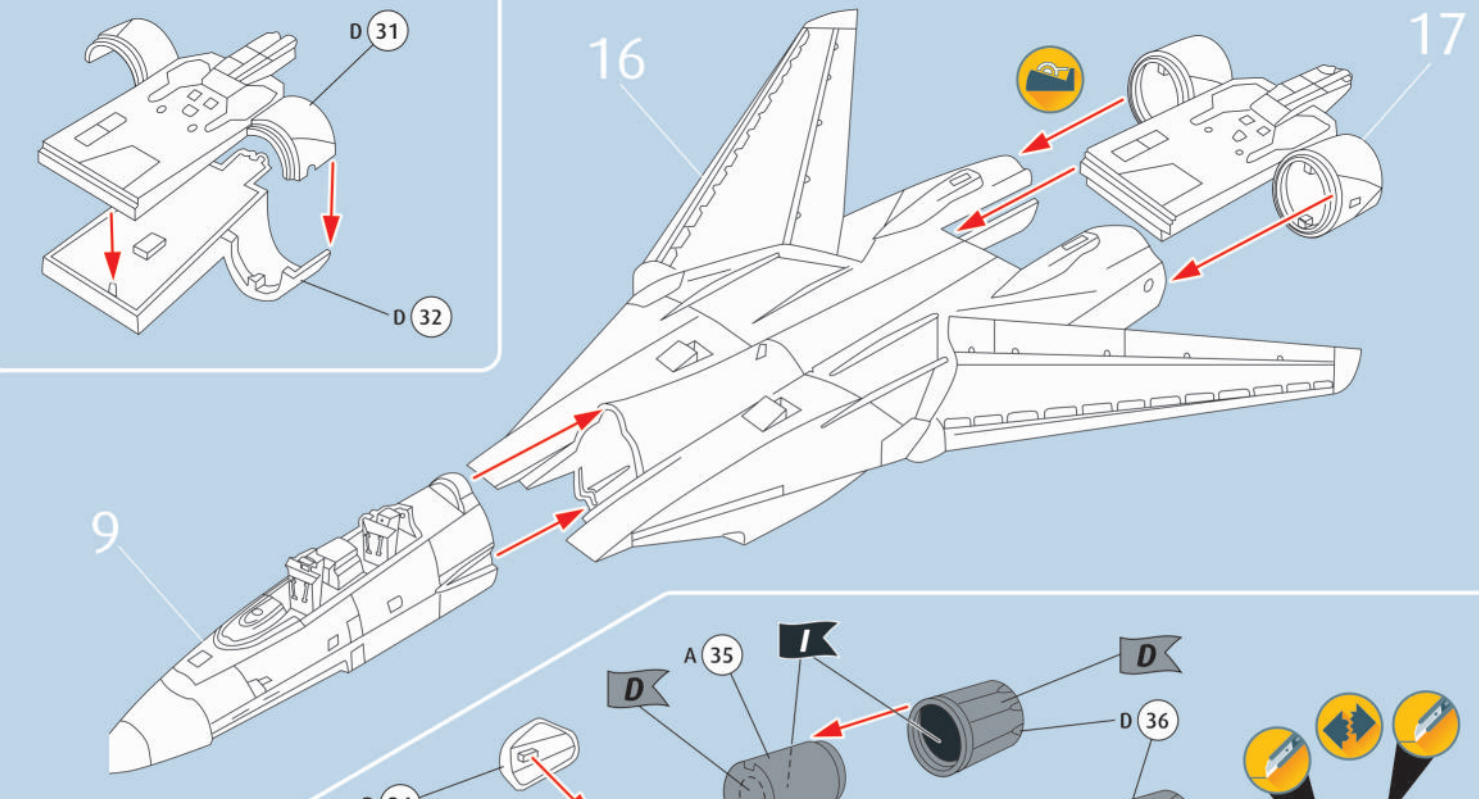

19

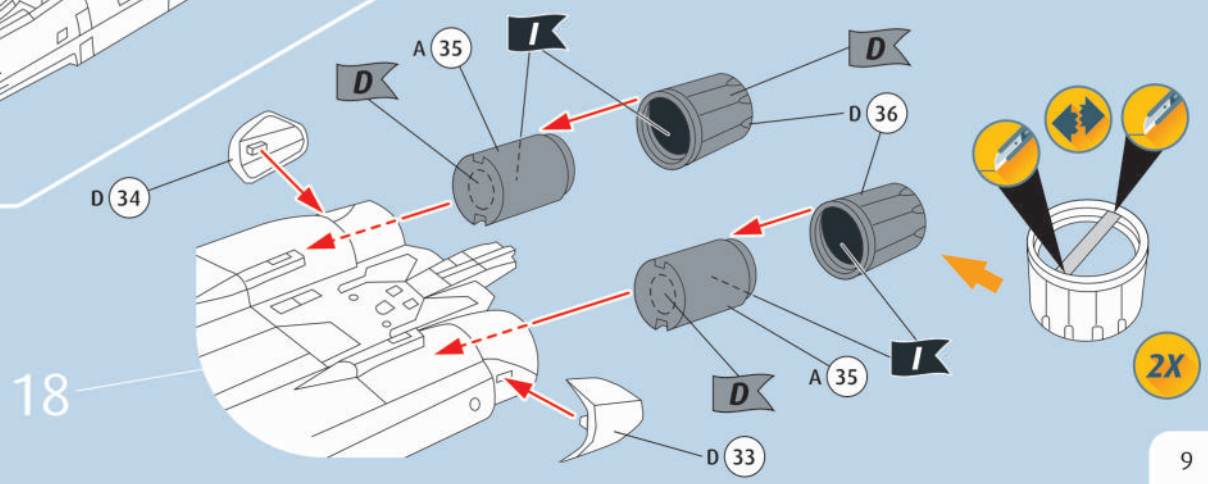

20 

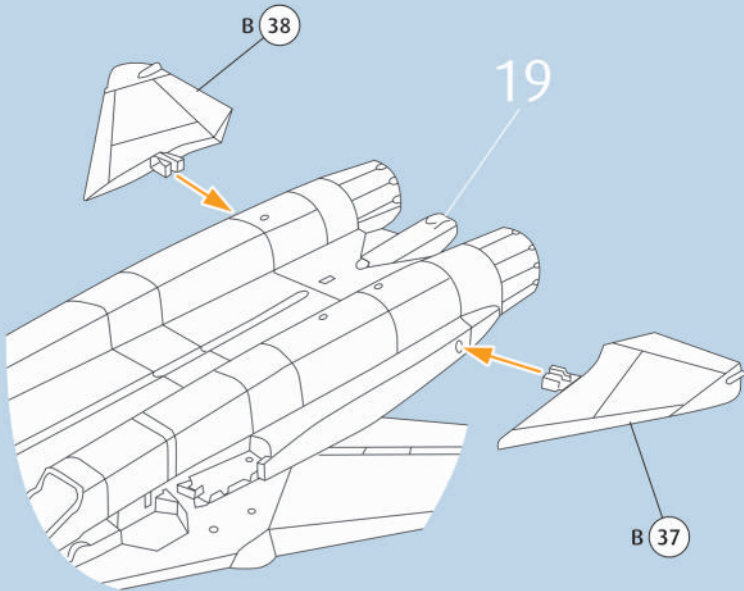

21 

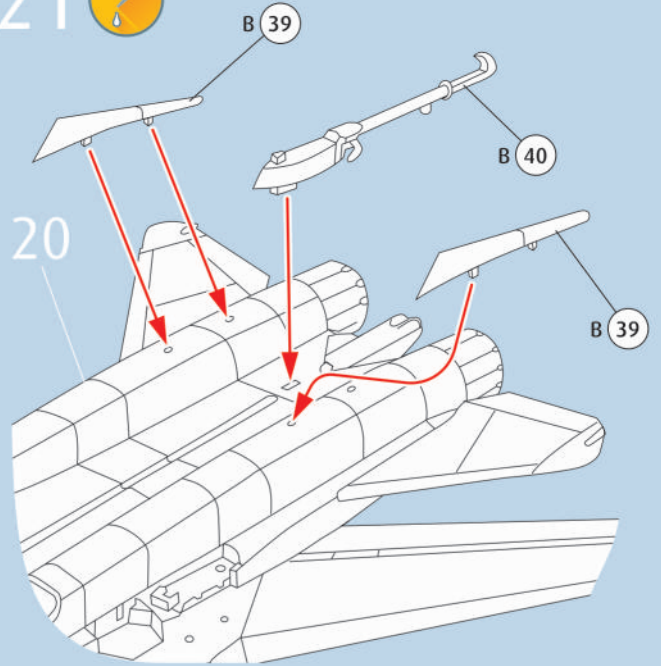

22  

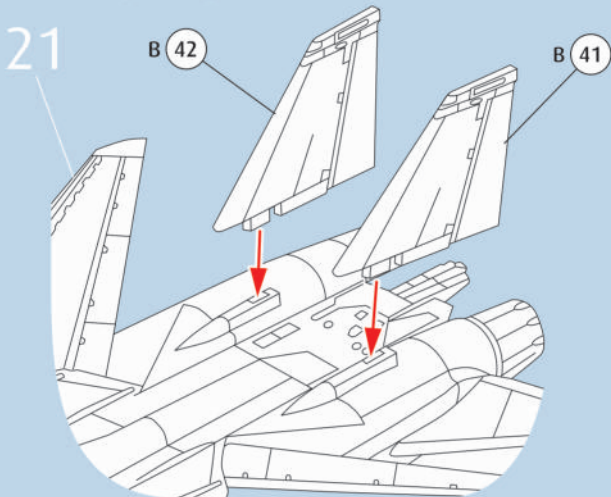

23   

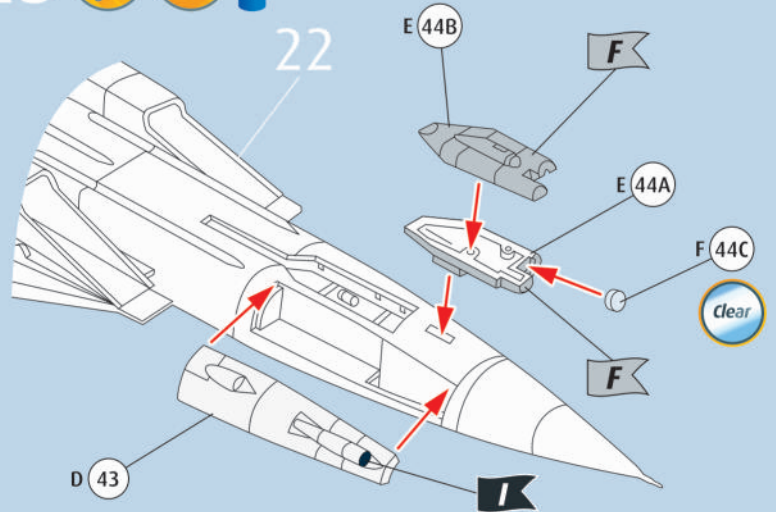

24   

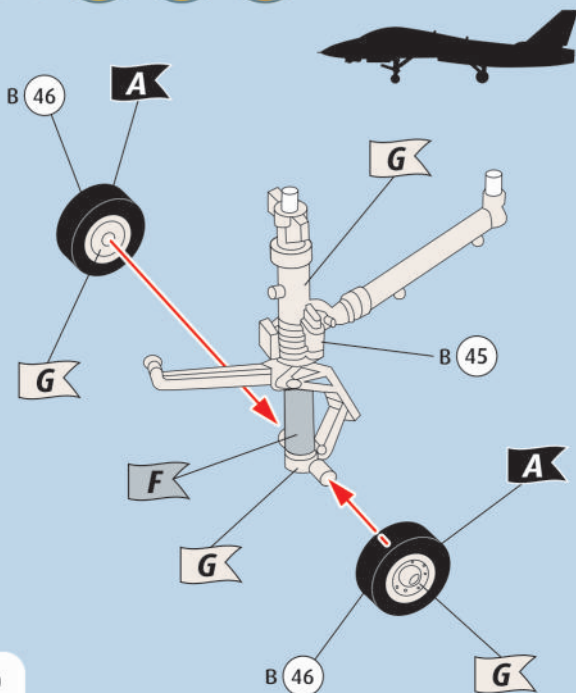

25    

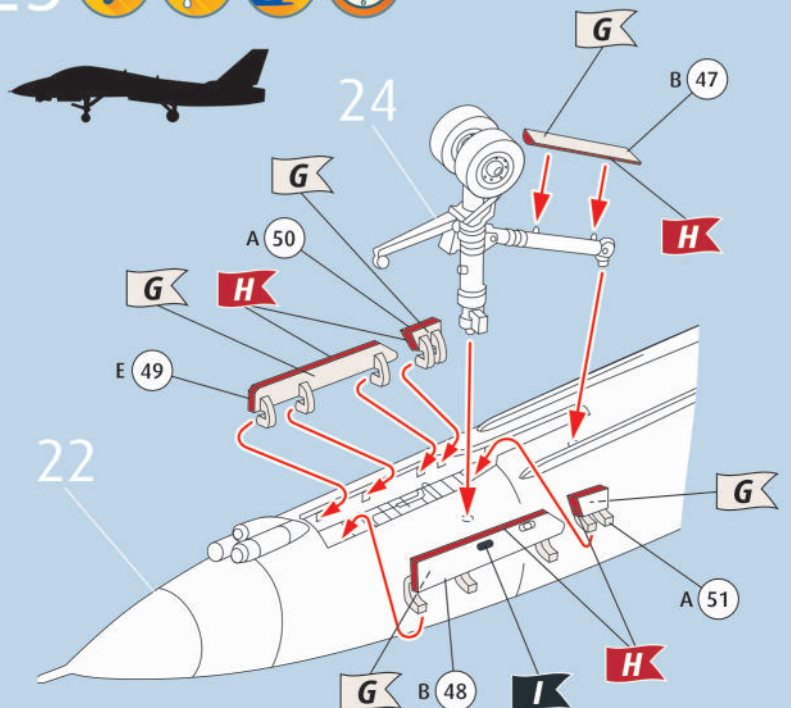

26 ? 

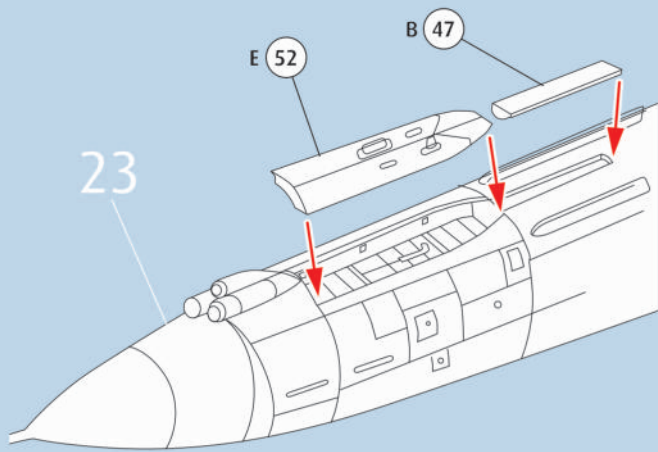

27 ?   

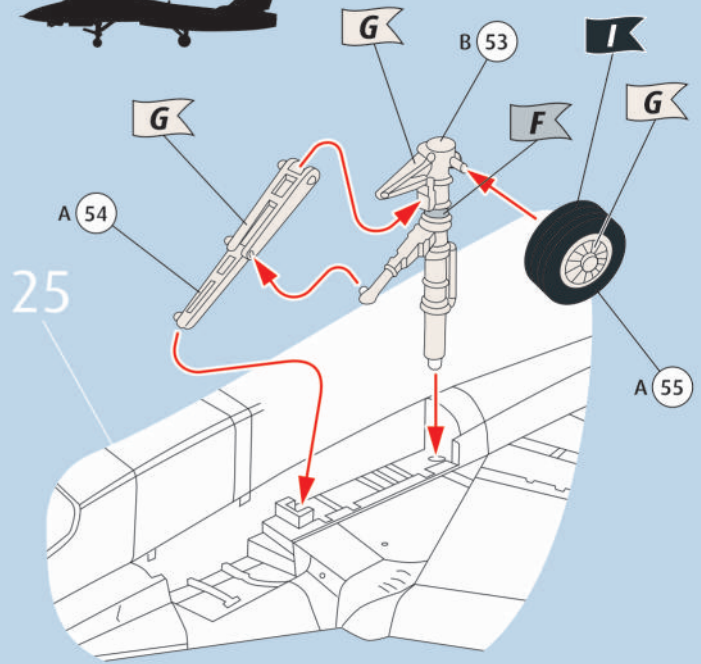

28 ?   

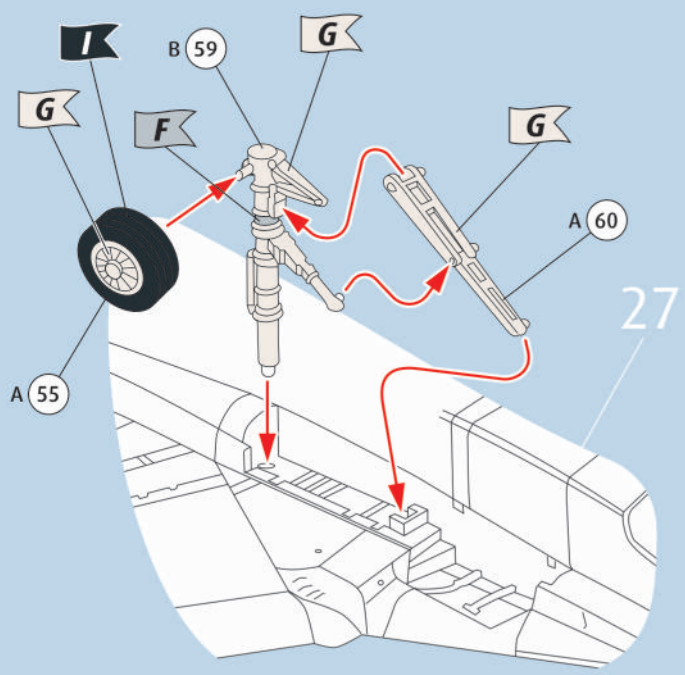

29 ?   

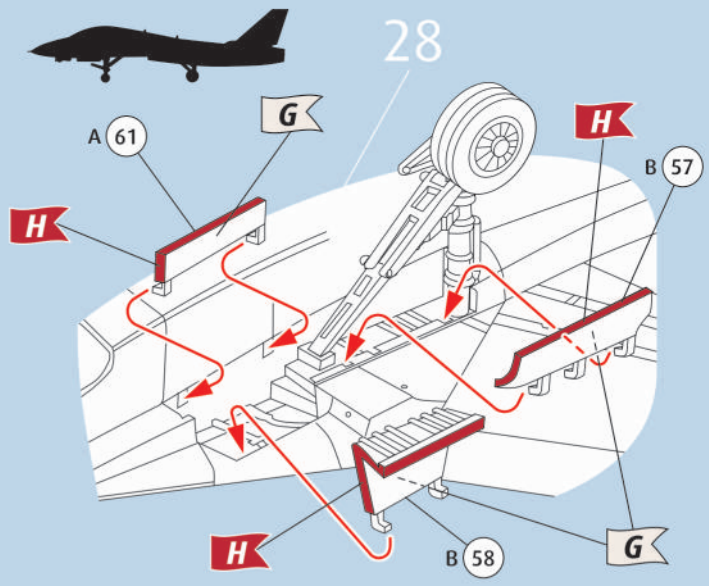

30 ?   

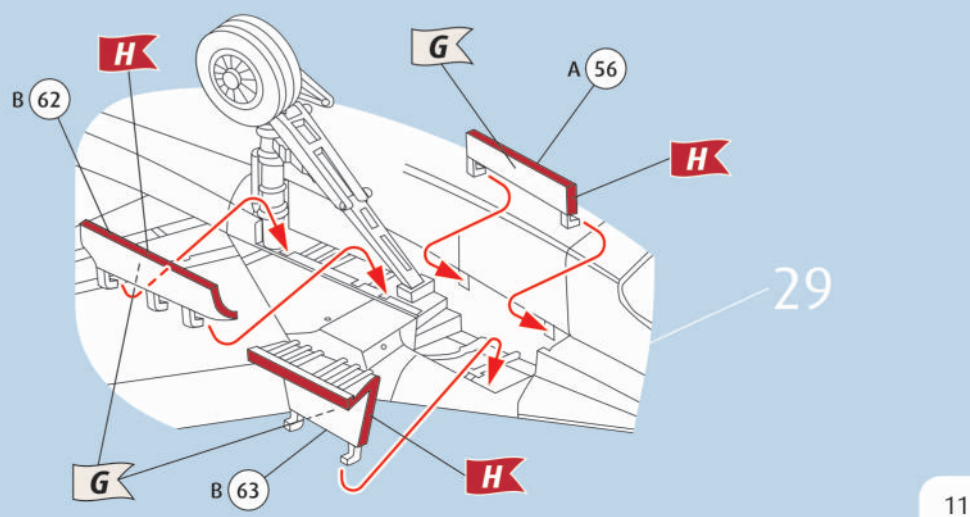

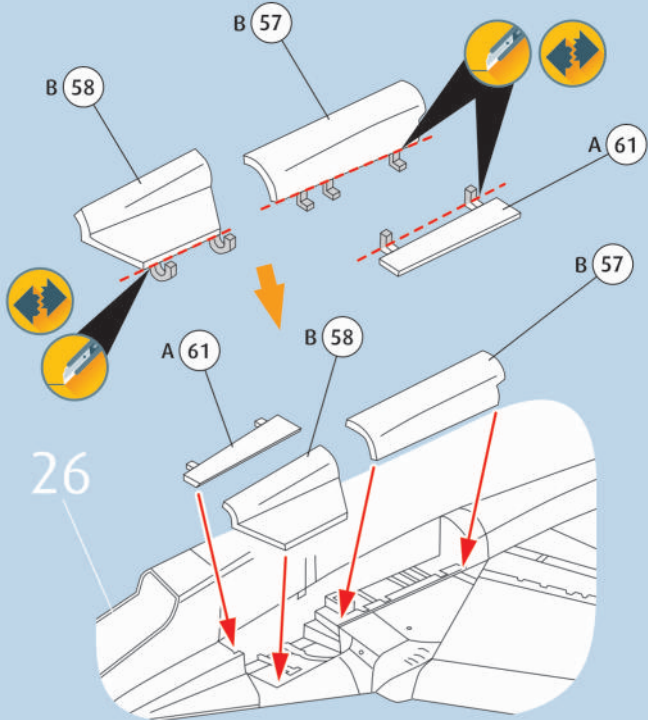
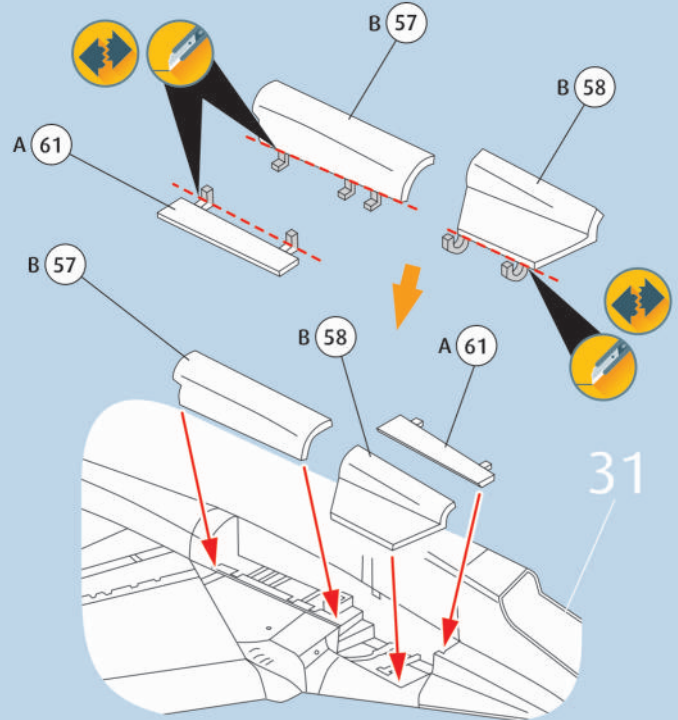
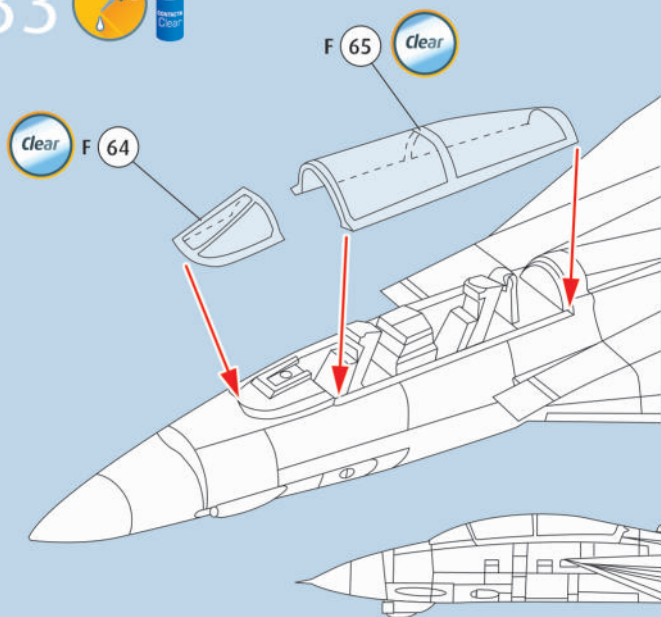
31  32  33  34   

AIM-54 Phoenix

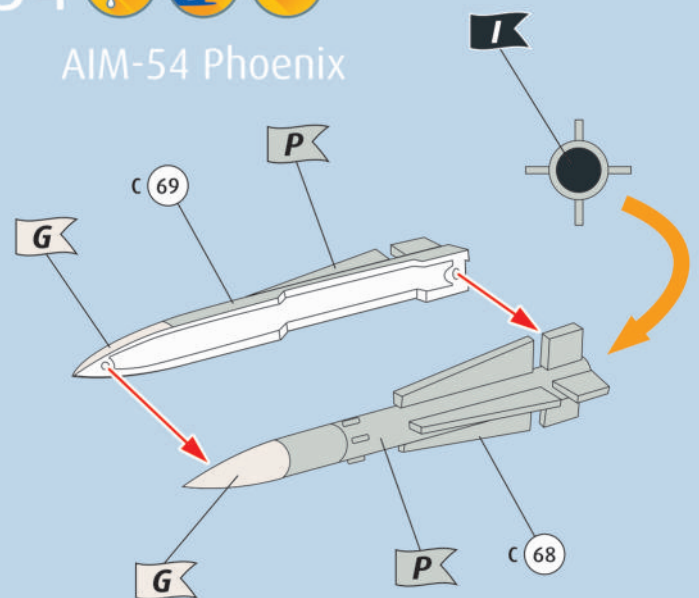
35  

AIM-9 Sidewinder

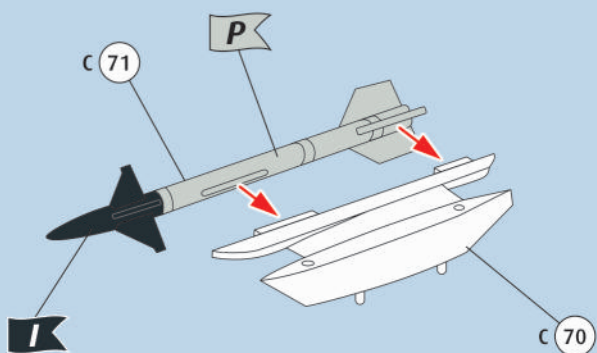
36  

AIM-9 Sidewinder

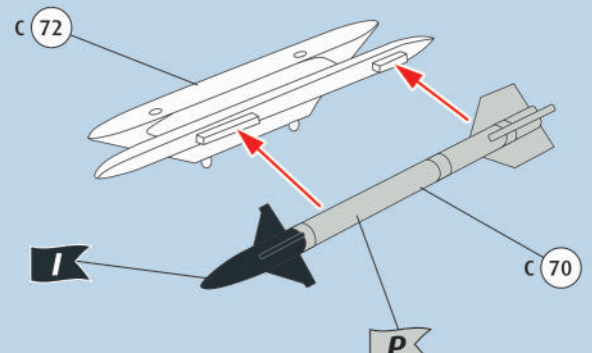

37 ? 

AIM-54 Phoenix

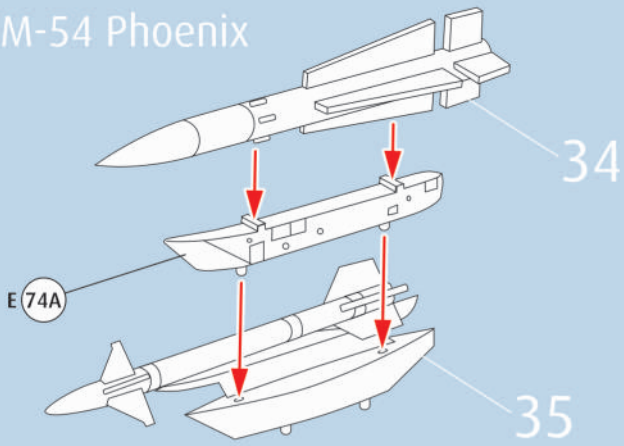

38 ? 

AIM-54 Phoenix

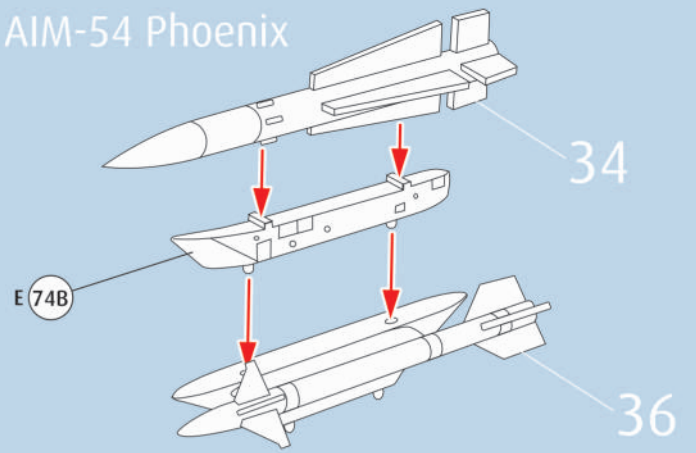

39 ?  

AIM-7 Sparrow

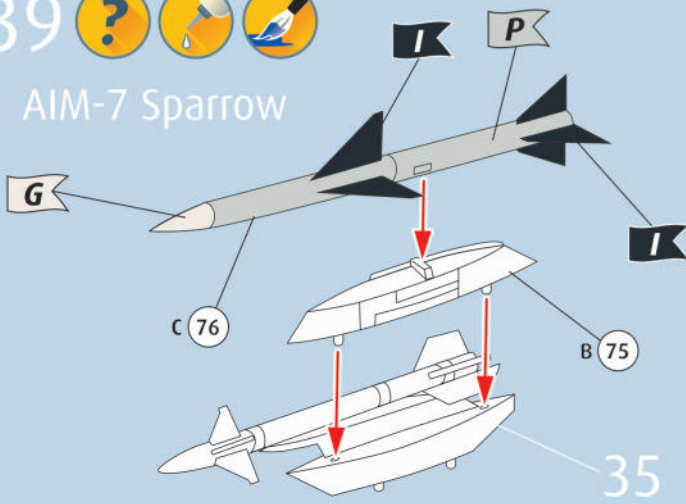

40 ?  

AIM-7 Sparrow

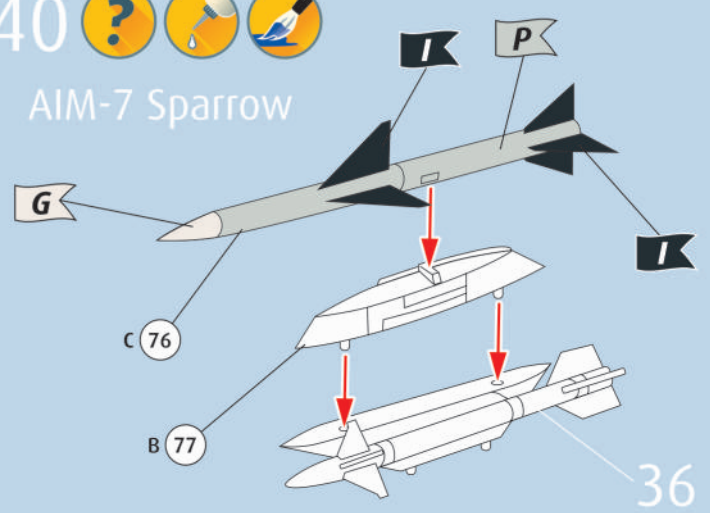

41 

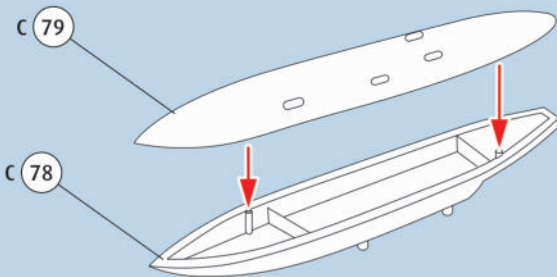

42 

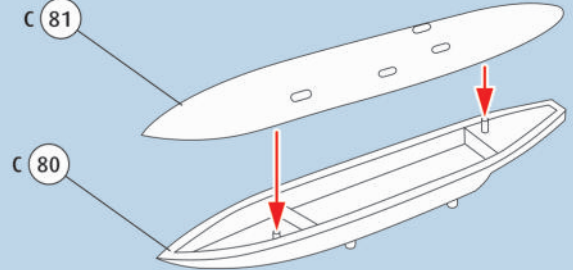

43 ?  

33

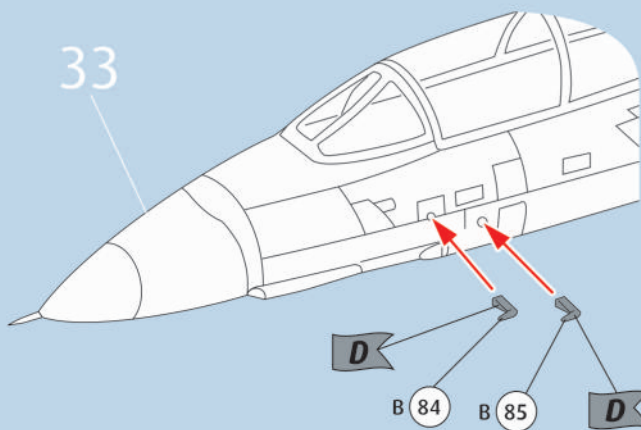

44 ?  

43

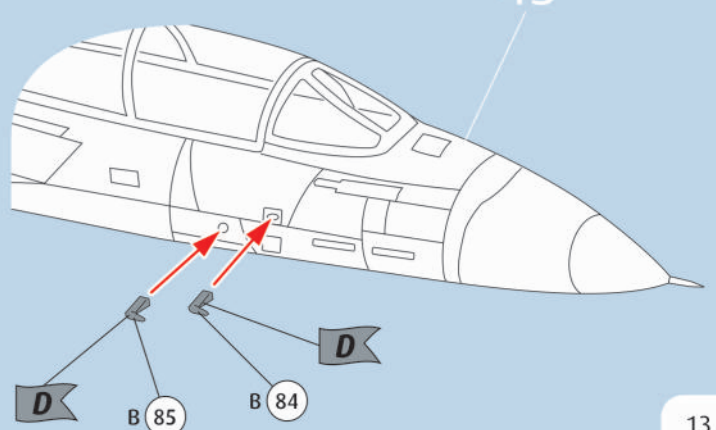

45 ?  

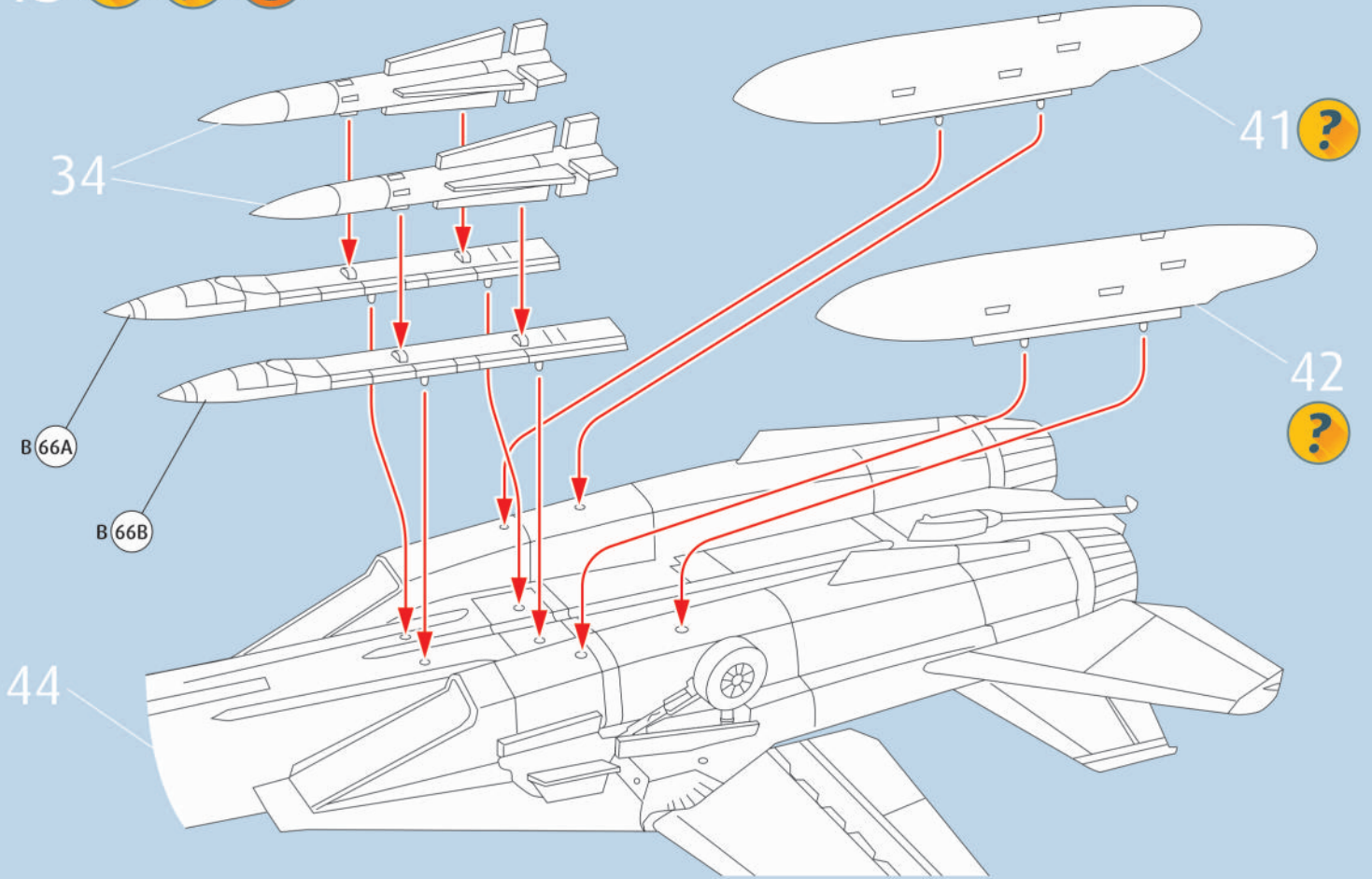

46 ?  

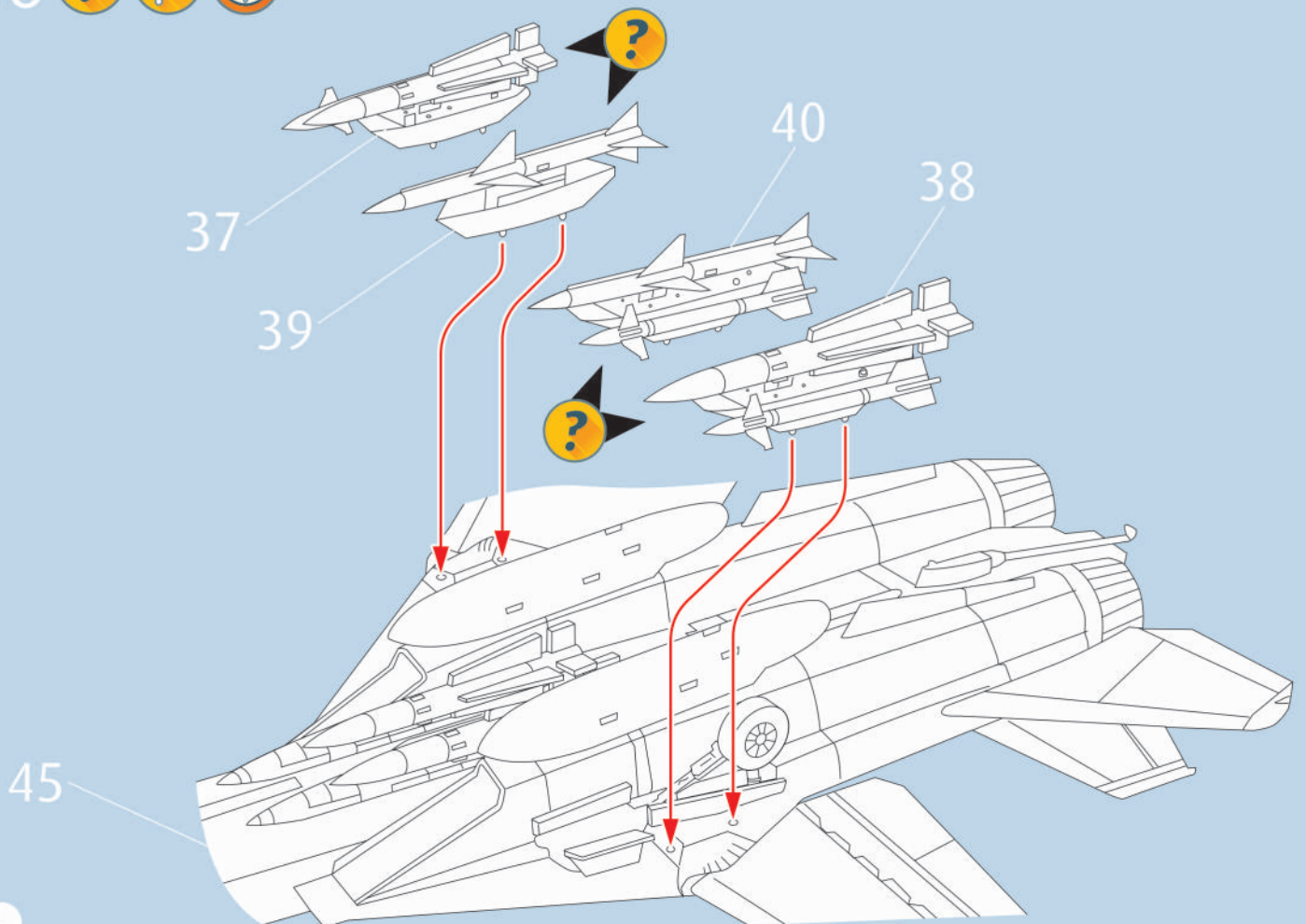

F-14D "Super Tomcat"-VF-101 Grim Reapers, NAS Oceana 2004

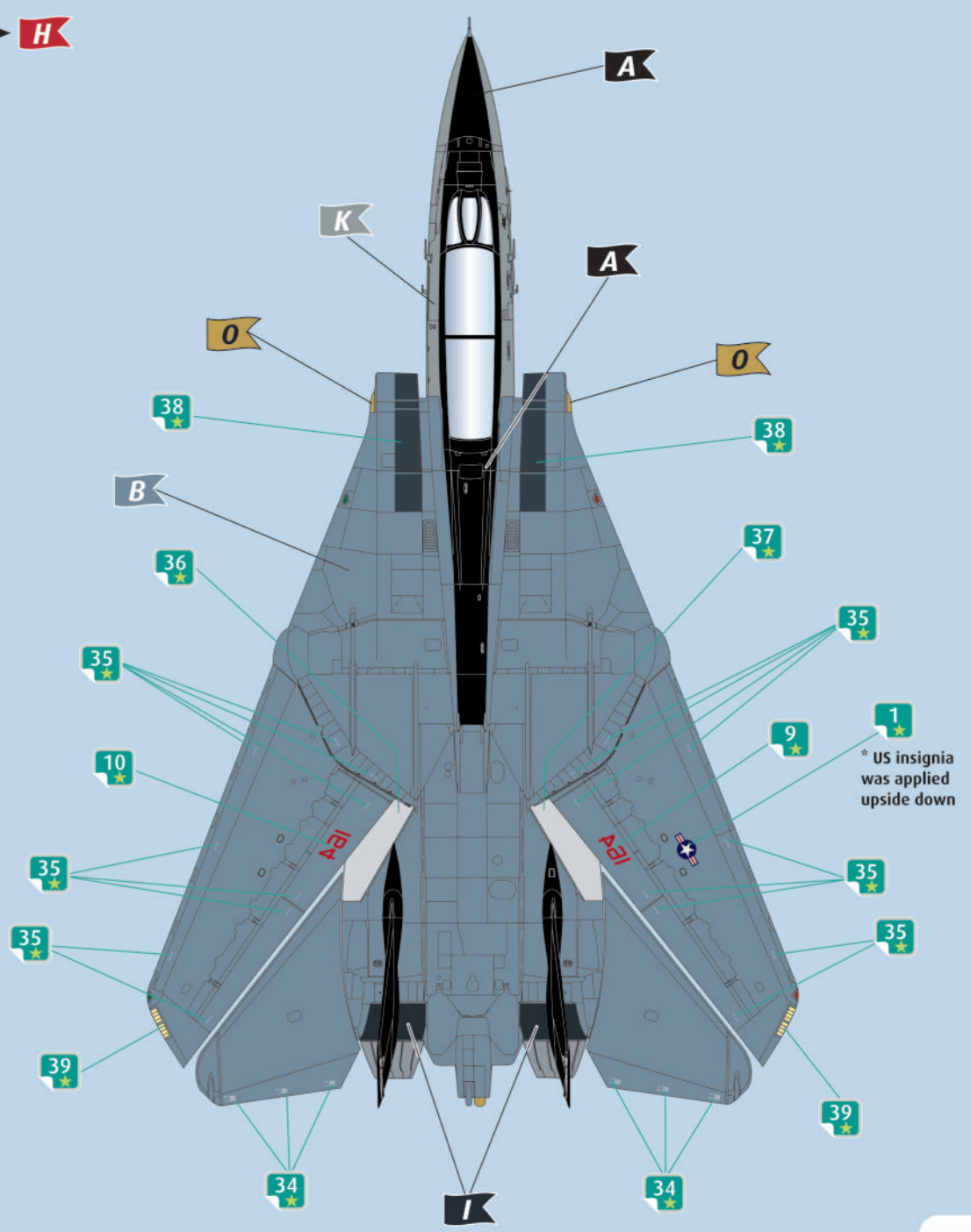
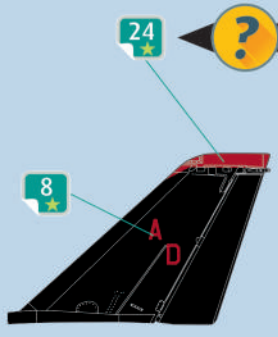
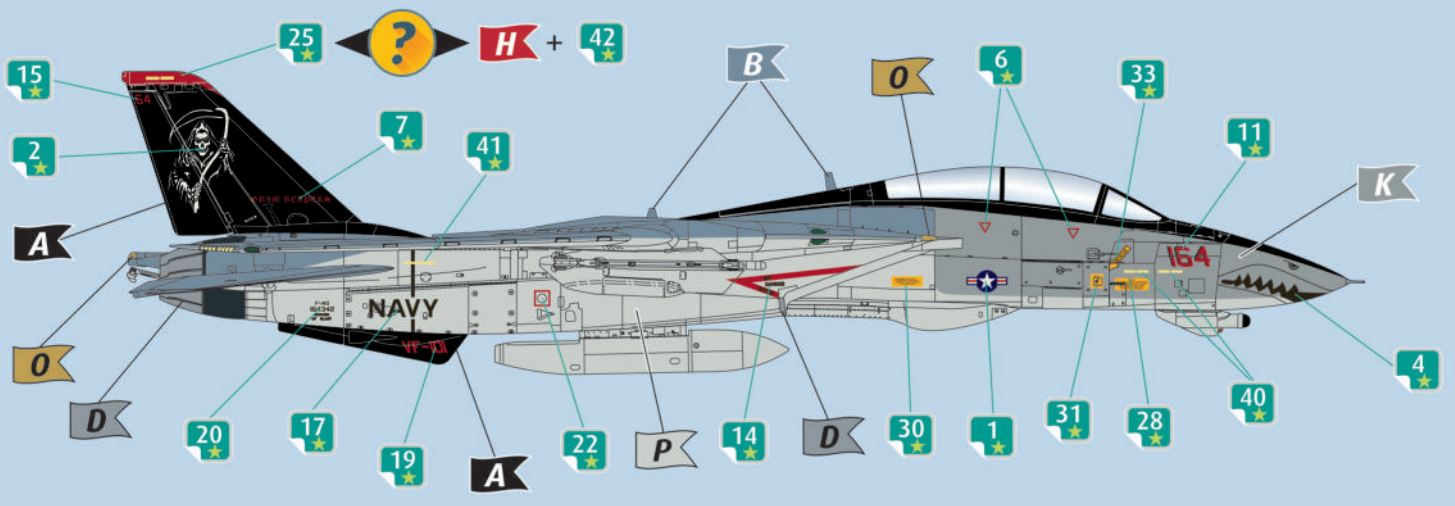

- A** FS 35237
- B**
- D**
- H**
- I** FS 36320
- K**
- O**
- P** FS 36375

* US insignia was applied upside down

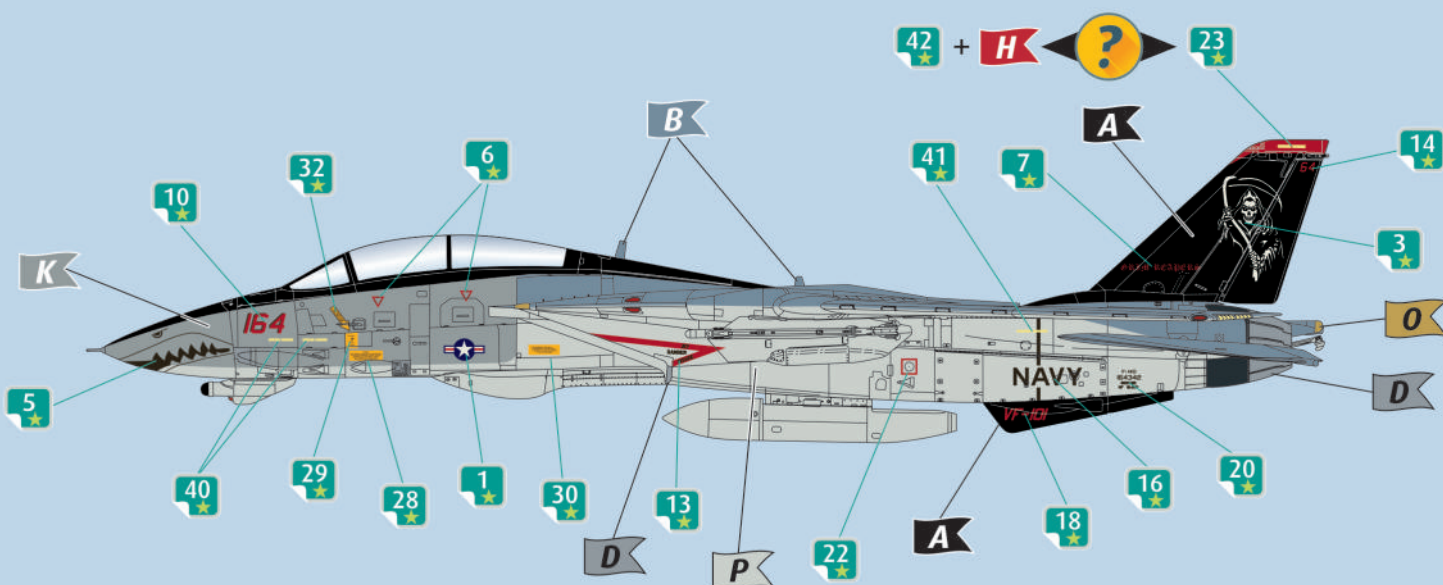

42 + H ? 23

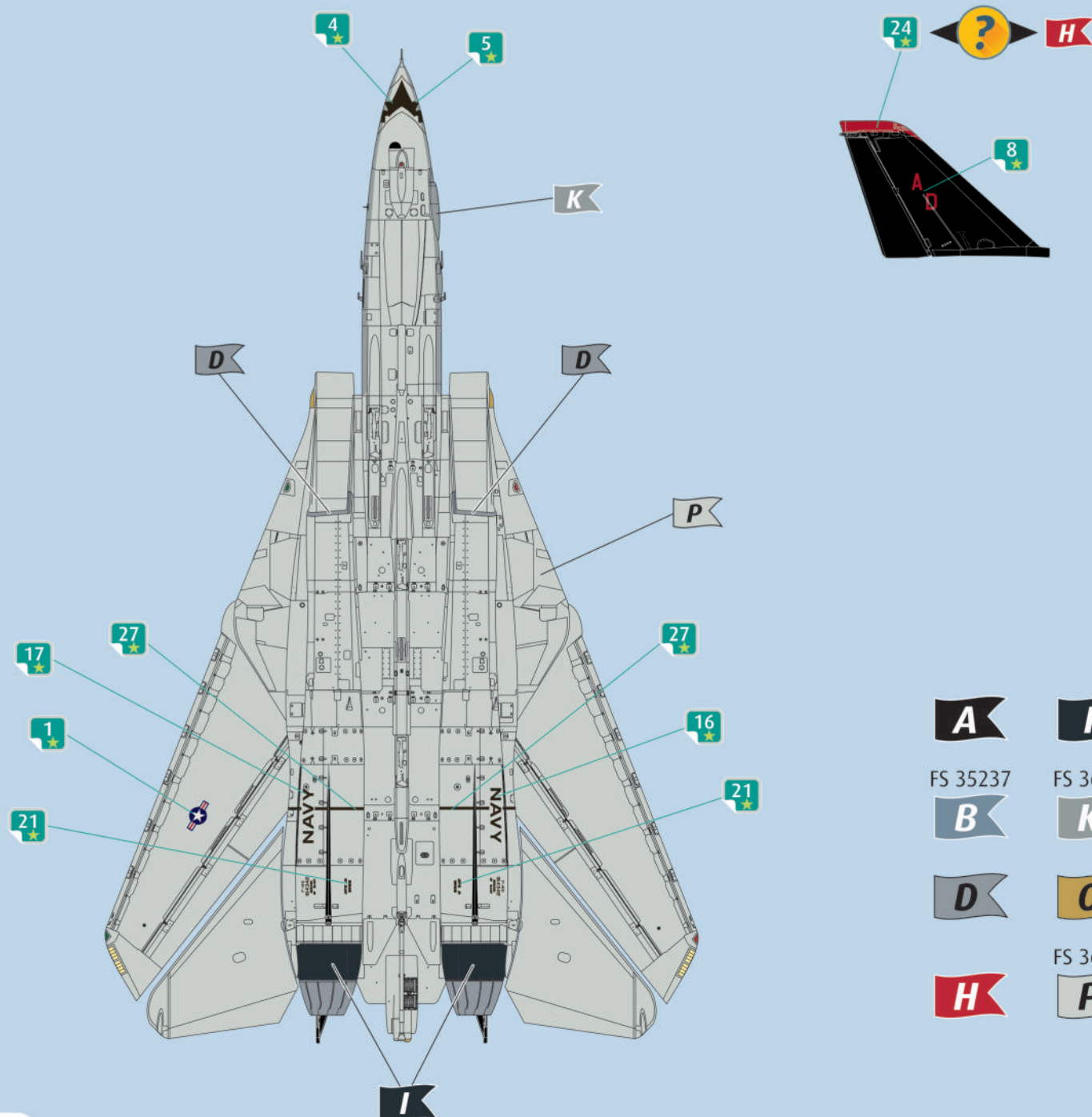

24 ? H

- | | |
|----------|----------|
| A | I |
| FS 35237 | FS 36320 |
| B | K |
| D | O |
| H | FS 36375 |
| | P |