

rolly toys Kundendienst Deutschland:

Tel: +49 (0) 95 68 / 856-142
 Fax: +49 (0) 95 68 / 856-183
 e-mail: service@rollytoys.de



Plattform / Platform

01 * *, 02 *** ***

2014/01

010.000.800.00

- **
- +12
- +22
- +80

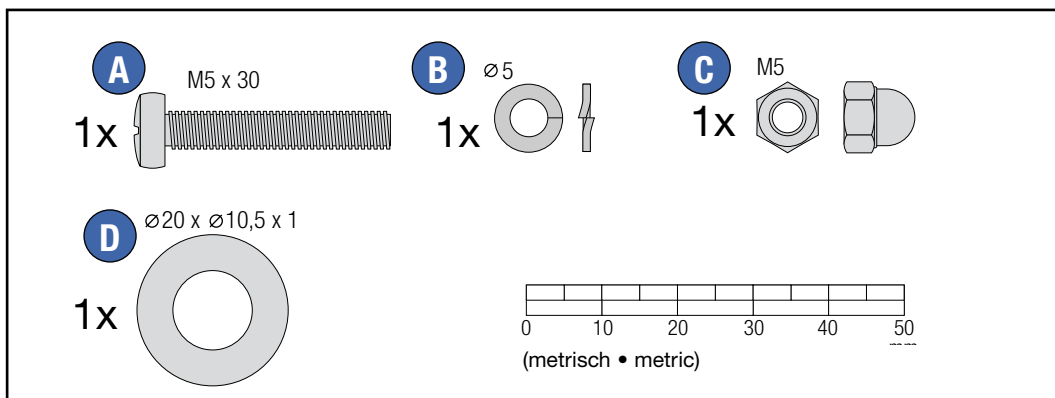
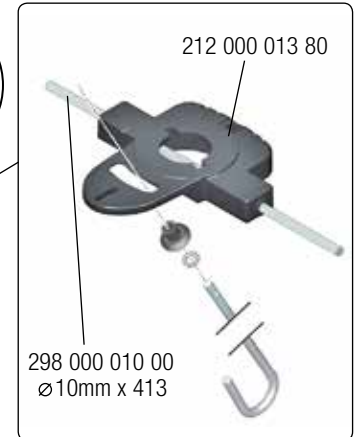
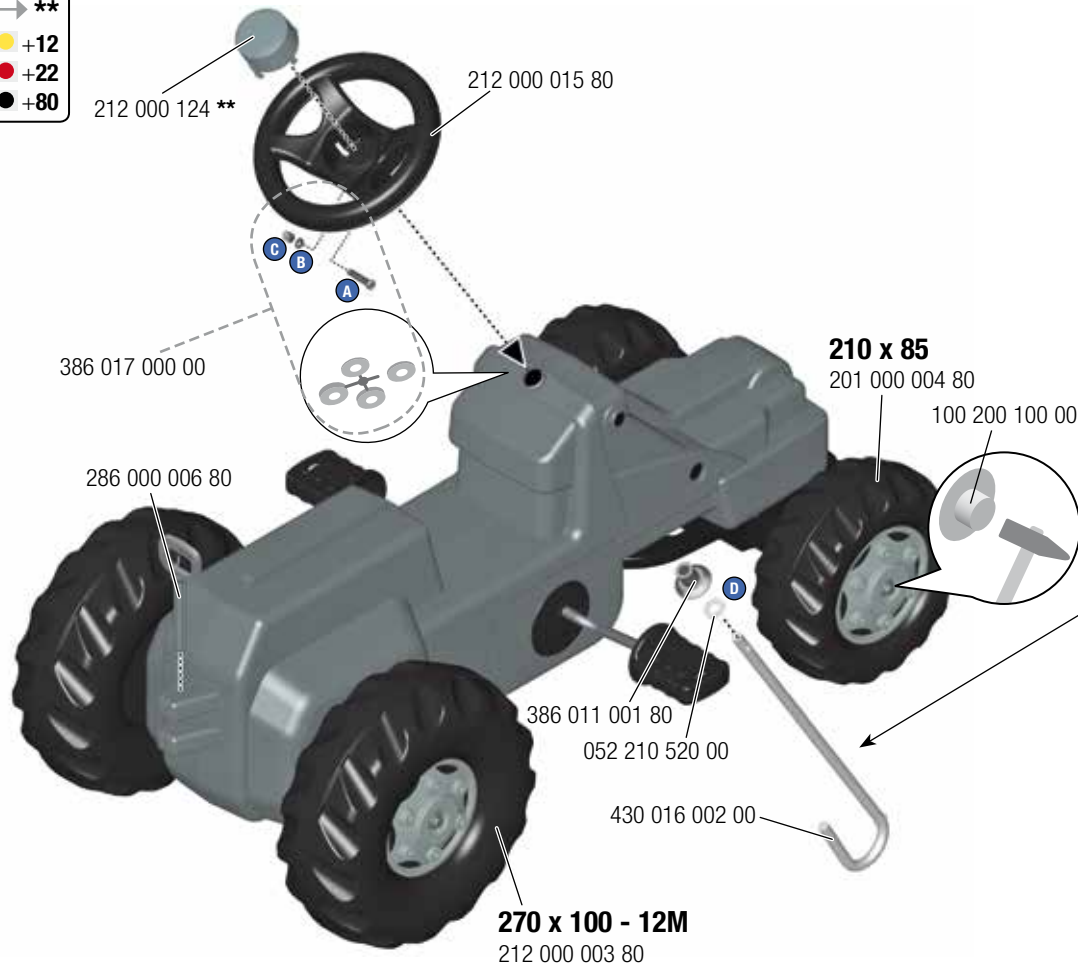

made in Germany

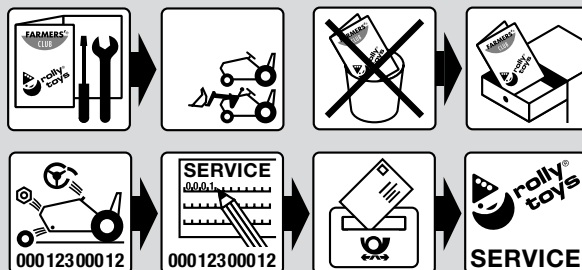

Franz Schneider GmbH & Co KG
 P.O.Box 1460
 D-96459 · Neustadt bei Coburg · Germany
 Tel.: +49 (0) 95 68 / 856-0
 Fax.: +49 (0) 95 68 / 856-190
 www.rollytoys.com

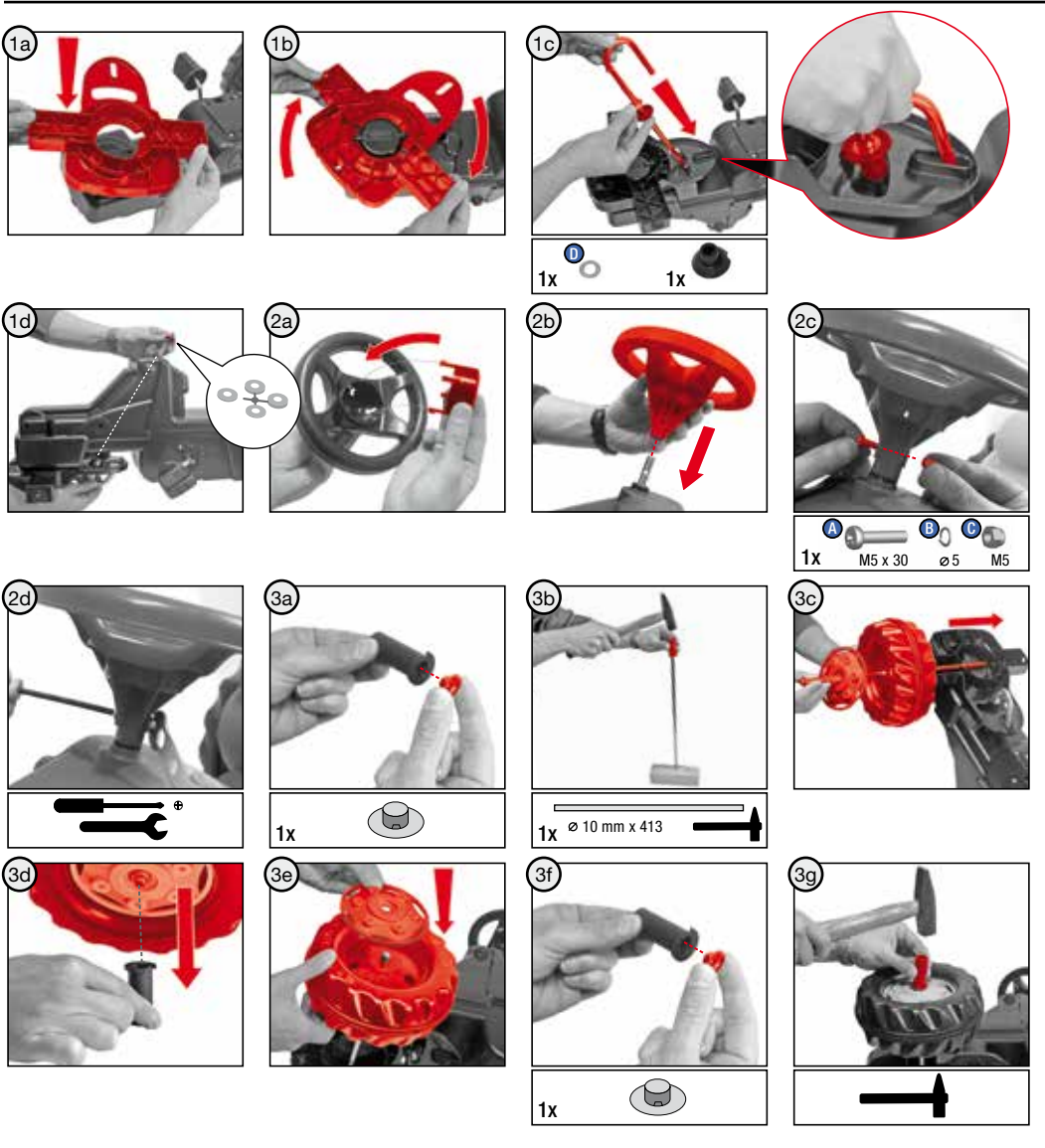

--- NORTH & SOUTH AMERICA only ---

180 days warranty

From the date of purchase + guaranteed spare part service
The warranty does not cover damages caused by improper use or neglect



WARNING

- **CHOKING HAZARD:** Small parts. Danger of being swallowed. Contains small parts in non assembled state. Must be assembled by adults.
- Adult supervision required.
- Never use near steps, slopes, driveways, hills, roadways, alleys or swimming pool areas.
- Always wear shoes.
- Never allow more than one rider.
- The use of protective gear and a safety helmet is highly recommended.
- Conforms to the requirements of ASTM Standard Consumer Safety Specification on Toy Safety, F 963

