



Questo manuale d'istruzione è fornito da [trovaprezzi.it](http://trovaprezzi.it). Scopri tutte le offerte per [Seagate SkyHawk 6 TB \(ST6000VX001\)](#) o cerca il tuo prodotto tra le [migliori offerte di Hard Disk interni](#)



# SKYHAWK

## SURVEILLANCE

SATA Product Manual

### **Standard models**

ST6000VX001

ST3000VX009

100825412, Rev. B  
Gen 17 - November 2017

## Document Revision History

Revision	Date	Pages affected
Rev. A	08/24/2017	Initial release.
Rev. B	11/21/2017	6: Revised bullet to - Supports up to 64 HD cameras for recording and playback 8 & 10: Updated Data transfer rate to 185 MB/s 14: Added Figure 1: Location of the HDA temperature check point 17-21: Updated Safety, EMC, FCC & RoHS Sections 2.12 through 2.13.3, per Compliance Council 23: Updated fastener penetration depth to 0.140 inches in Section 3.4 & Figure 2

**© 2017 Seagate Technology LLC. All rights reserved.**

Publication number: 100825412, Rev. B November 2017

Seagate, Seagate Technology and the Spiral Logo are registered trademarks of Seagate Technology LLC in the United States and/or other countries. SkyHawk and SeaTools are either trademarks or registered trademarks of Seagate Technology LLC or one of its affiliated companies in the United States and/or other countries. All other trademarks or registered trademarks are the property of their respective owners.

No part of this publication may be reproduced in any form without written permission of Seagate Technology LLC.

Call 877-PUB-TEK1 (877-782-8351) to request permission.

When referring to drive capacity, one gigabyte, or GB, equals one billion bytes and one terabyte, or TB, equals one trillion bytes. Your computer's operating system may use a different standard of measurement and report a lower capacity. In addition, some of the listed capacity is used for formatting and other functions, and thus will not be available for data storage. Actual quantities will vary based on various factors, including file size, file format, features and application software. Actual data rates may vary depending on operating environment and other factors. The export or re-export of hardware or software containing encryption may be regulated by the U.S. Department of Commerce, Bureau of Industry and Security (for more information, visit [www.bis.doc.gov](http://www.bis.doc.gov)), and controlled for import and use outside of the U.S. Seagate reserves the right to change, without notice, product offerings or specifications.

<b>Seagate® Technology Support Services</b> .....	<b>5</b>
---	----------

---

<b>1.0 Introduction</b> .....	<b>6</b>
1.1 About the SATA interface .....	7

---

<b>2.0 Drive Specifications</b> .....	<b>8</b>
2.1 Specification summary tables .....	8
2.2 Formatted capacity .....	10
2.2.1 LBA mode .....	10
2.3 Default logical geometry .....	10
2.4 Recording and interface technology .....	10
2.5 Physical characteristics .....	11
2.6 Start/stop times .....	11
2.7 Power specifications .....	12
2.7.1 Power consumption .....	12
2.7.2 Conducted noise .....	13
2.7.3 Voltage tolerance .....	13
2.7.4 Power-management modes .....	13
2.8 Environmental specifications .....	14
2.8.1 Ambient Temperature .....	14
2.8.2 Temperature gradient .....	14
2.8.3 Humidity .....	14
2.8.4 Altitude .....	15
2.8.5 Shock .....	15
2.8.6 Vibration .....	15
2.9 Acoustics .....	16
2.9.1 Test for Prominent Discrete Tones (PDTs) .....	16
2.10 Electromagnetic immunity .....	16
2.11 Warranty .....	17
2.11.1 Data loss under power interruption with write cache enabled .....	17
2.11.2 Storage .....	17
2.12 Agency and Safety Certifications .....	17
2.12.1 Safety certification .....	17
2.12.2 European Union (EU) CE Marking Requirements .....	17
2.12.3 Australian RCM Compliance Mark .....	18
2.12.4 Canada ICES-003 .....	18
2.12.5 South Korean KC Certification Mark .....	18
2.12.6 Morocco Commodity Mark .....	18
2.12.7 Taiwanese BSMI .....	18
2.12.8 FCC verification .....	19
2.13 Environmental protection .....	19
2.13.1 European Union Restriction of Hazardous Substance Law .....	19
2.13.2 China Requirements —China RoHS 2 .....	20
2.13.3 Taiwan Requirements — Taiwan RoHS .....	21
2.14 Corrosive environment .....	21

---

<b>3.0</b>	<b>Configuring and Mounting the Drive</b> .....	<b>22</b>
3.1	Handling and static-discharge precautions .....	22
3.2	Configuring the drive .....	22
3.3	SATA cables and connectors .....	22
3.4	Drive mounting .....	23

---

<b>4.0</b>	<b>SATA Interface</b> .....	<b>25</b>
4.1	Hot-Plug compatibility .....	25
4.2	SATA device plug connector pin definitions .....	25
4.3	Supported ATA commands .....	26
4.3.1	Identify Device command .....	28
4.3.2	Set Features command .....	33
4.3.3	S.M.A.R.T. commands .....	34

# Figures

Figure 1	Attaching SATA cabling.....	22
Figure 2	Mounting dimensions (3TB models).....	23
Figure 3	Mounting dimensions (6TB models).....	24

# Seagate® Technology Support Services

For information regarding online support and services, visit: <http://www.seagate.com/contacts/>

For information regarding Warranty Support, visit: <http://www.seagate.com/support/warranty-and-replacements/>

For information regarding data recovery services, visit: <http://www.seagate.com/services-software/recover/>

For Seagate OEM, Distribution partner and reseller portals, visit: <http://www.seagate.com/partners/>

## 1.0 Introduction

---

This manual describes the functional, mechanical and interface specifications for the following Seagate® Skyhawk and model drives:

### **SkyHawk models**

ST6000VX001      ST3000VX009

These drives provide the following key features:

- 1M hour MTBF - designed for high write duty cycle across SkyHawk
- ATA AV Command support - streaming video command support across SkyHawk
- Best-in-class acoustic performance means virtually silent operation
- Built-in error recovery for non-stop video streaming
- Compliant with RoHS requirements in China and Europe
- Full-track multiple-sector transfer capability without local processor intervention
- Idle3 power mode support
- Low activity power
- Low-RPM spindle speed
- Native Command Queuing with command ordering to increase performance in demanding applications
- Performance-tuned for seamless video applications
- Reliability for 24x7 video surveillance applications
- Rotational Vibration - mitigation of system level rotational vibration inside SkyHawk
- SeaTools diagnostic software performs a drive self-test that eliminates unnecessary drive returns.
- State-of-the-art cache and on-the-fly error-correction algorithms
- Streaming video optimization - consistent command completion times & ERC support across SkyHawk
- Support for S.M.A.R.T. drive monitoring and reporting
- Supports "8+" drive bays
- Supports ATA8 streaming commands
- Supports latching SATA cables and connectors
- Supports up to 64 HD cameras for recording and playback
- TGMR recording technology provides the drives with increased areal density.
- Thermal monitoring and reporting for 24x7 operations
- Transient power on management -  $\leq 1.8A$  spin-up current
- Uncompromising reliability supports flexible surveillance design with case temperatures up to 70°C
- Workload ratings of 180TB/year
- Worldwide Name (WWN) capability uniquely identifies the drive

## 1.1 About the SATA interface

The Serial ATA (SATA) interface provides several advantages over the traditional (parallel) ATA interface. The primary advantages include:

- Easy installation and configuration with true plug-and-play connectivity. It is not necessary to set any jumpers or other configuration options.
- Thinner and more flexible cabling for improved enclosure airflow and ease of installation.
- Scalability to higher performance levels.

In addition, SATA makes the transition from parallel ATA easy by providing legacy software support. SATA was designed to allow users to install a SATA host adapter and SATA disk drive in the current system and expect all of the existing applications to work as normal.

The SATA interface connects each disk drive in a point-to-point configuration with the SATA host adapter. There is no master/slave relationship with SATA devices like there is with parallel ATA. If two drives are attached on one SATA host adapter, the host operating system views the two devices as if they were both “masters” on two separate ports. This essentially means both drives behave as if they are Device 0 (master) devices.

The SATA host adapter and drive share the function of emulating parallel ATA device behavior to provide backward compatibility with existing host systems and software. The Command and Control Block registers, PIO and DMA data transfers, resets, and interrupts are all emulated.

The SATA host adapter contains a set of registers that shadow the contents of the traditional device registers, referred to as the Shadow Register Block. All SATA devices behave like Device 0 devices. For additional information about how SATA emulates parallel ATA, refer to the “Serial ATA International Organization: Serial ATA Revision 3.0”. The specification can be downloaded from [www.sata-io.org](http://www.sata-io.org).

**Note**

The host adapter may, optionally, emulate a master/slave environment to host software where two devices on separate SATA ports are represented to host software as a Device 0 (master) and Device 1 (slave) accessed at the same set of host bus addresses. A host adapter that emulates a master/slave environment manages two sets of shadow registers. This is not a typical SATA environment.

## 2.0 Drive Specifications

Unless otherwise noted, all specifications are measured under ambient conditions, at 25°C, and nominal power. For convenience, the phrases *the drive* and *this drive* are used throughout this manual to indicate the following drive models:

### SkyHawk models

ST6000VX001      ST3000VX009

## 2.1 Specification summary tables

The specifications listed in [Table 1](#) are for quick reference. For details on specification measurement or definition, refer to the appropriate section of this manual.

**Table 1 Drive specifications summary for 6TB & 3TB model**

Drive Specification*	ST6000VX001	ST3000VX009
Formatted capacity (512 bytes/sector)**	6000GB (6TB)	3000GB (3TB)
Guaranteed sectors	11,721,045,168	5,860,533,168
Heads	8	4
Disks	4	2
Bytes per sector (emulated at 512-byte sectors)	4096 (physical)	
Default sectors per track	63	
Default read/write heads	16	
Default cylinders	16,383	
Recording density (max)	2294 kB/in	
Track density (avg)	540 ktracks/in	
Areal density (avg)	1203 Gb/in <sup>2</sup>	
SATA interface transfer rate	600 MB/s	
Maximum data transfer rate	185 MB/s	
ATA data-transfer modes supported	PIO modes: 0 to 4 Multiword DMA modes: 0 to 2 Ultra DMA modes 0 to 6	
Cache buffer	256MB	
Height (max)	26.1mm / 1.028 in	20.20mm / 0.795 in
Width (max)	101.6mm (± 0.25) / 4.0 in (± 0.010)	
Length (max)	146.99mm / 5.787 in	
Weight (typical)	610g / 1.345 lb	490g / 1.08 lb
Average latency	6.0 ms	
Power-on to ready (typ)	15.0s	10.0s
Standby to ready (typ)	15.0s	10.0s
Startup current (typical) 12V	1.8A	
Voltage tolerance (including noise)	5V ±5% 12V ±10%	
Non-Operating (Ambient °C)	-40° to 70°	
Operating ambient temperature (min °C) #	0°	
Operating temperature (drive case max °C)	70°†	
Temperature gradient	20°C per hour max (operating) 30°C per hour max (non-operating)	
Relative humidity	5% to 90% (operating) 5% to 95% (non-operating)	
Relative humidity gradient (max)	30% per hour	

**Table 1 Drive specifications summary for 6TB & 3TB model (continued)**

Drive Specification*	ST6000VX001	ST3000VX009
Wet bulb temperature (max)	30°C max (operating) 40°C max (non-operating)	
Altitude, operating	-304m to 3048m (-1000 ft to 10,000 ft)	
Altitude, non-operating (below mean sea level, max)	-304m to 12,192m (-1000 ft to 40,000+ ft)	
Operational shock (max)	80 Gs (read) / 70 Gs (write) at 2ms	
Non-operational shock (max)	300 Gs at 2ms	
Vibration, operating	10Hz to 22Hz: 0.25 Gs, Limited displacement 22Hz to 350Hz: 0.50 Gs 350Hz to 500Hz: 0.25 Gs	
Vibration, non-operating	5Hz to 22Hz: 3.0 Gs 22Hz to 350Hz: 3.0 Gs 350Hz to 500Hz: 3.0 Gs	
Drive acoustics, sound power		
Idle***	2.3 bels (typical) 2.5 bels (max)	2.1 bels (typical) 2.2 bels (max)
Seek	2.5 bels (typical) 2.6 bels (max)	2.3 bels (typical) 2.4 bels (max)
Non-recoverable read errors	1 per 10 <sup>15</sup> bits read	
Rated workload	Average annualized workload rating: <180TB/year. The specifications for the product assumes the I/O workload does not exceed the average annualized workload rate limit of 180TB/year. Workloads exceeding the annualized rate may degrade and impact reliability as experienced by the particular application. The average annualized workload rate limit is in units of TB per calendar year.	
Warranty	To determine the warranty for a specific drive, use a web browser to access the following web page: <a href="http://www.seagate.com/support/warranty-and-replacements/">http://www.seagate.com/support/warranty-and-replacements/</a> From this page, click on "Is my Drive under Warranty". Users will be asked to provide the drive serial number, model number (or part number) and country of purchase. The system will display the warranty information for the drive.	
Load/unload cycles	600,000 at 25°C, 50% rel. humidity	
Supports hotplug operation per the Serial ATA Revision 3.2 specification	Yes	

\* All specifications above are based on native configurations.

\*\* One GB equals one billion bytes and 1TB equals one trillion bytes when referring to hard drive capacity. Accessible capacity may vary depending on operating environment and formatting.

\*\*\* During periods of drive idle, some offline activity may occur according to the S.M.A.R.T. specification, which may increase acoustic and power to operational levels.

† Seagate does not recommend operating at sustained case temperatures above 60°C. Operating at higher temperatures will reduce useful life of the product.

# The operating case temperature is 0 to 70C (32 to 158F). The recommended measure location can be found in Section 3.4 Figure 2 & 3..

<b>Note</b>	If the drive is powered-off before issuing flush cache command, in some instances, the end user data in the DRAM cache might not be committed to the disk.
-------------	--

## 2.2 Formatted capacity

Model	Formatted capacity*	Guaranteed sectors	Bytes per sector
6TB	6000GB	11,721,045,168	4096
3TB	3000GB	5,860,533,168	

\*One GB equals one billion bytes and 1TB equals one trillion bytes when referring to hard drive capacity. Accessible capacity may vary depending on operating environment and formatting.

### 2.2.1 LBA mode

When addressing these drives in LBA mode, all blocks (sectors) are consecutively numbered from 0 to  $n-1$ , where  $n$  is the number of guaranteed sectors as defined above.

See Section 4.3.1, "Identify Device command" (words 60-61 and 100-103) for additional information about 48-bit addressing support of drives with capacities over 137GB.

## 2.3 Default logical geometry

- **Cylinders:** 16,383
- **Read/write heads:** 16
- **Sectors per track:** 63

### LBA mode

When addressing these drives in LBA mode, all blocks (sectors) are consecutively numbered from 0 to  $n-1$ , where  $n$  is the number of guaranteed sectors as defined above.

## 2.4 Recording and interface technology

<b>Interface</b>	SATA
<b>Recording method</b>	TGMR
<b>Recording density (kBPI)</b>	2294
<b>Track density (ktracks/inch avg)</b>	540
<b>Areal density (Gb/in<sup>2</sup>)</b>	1203
<b>Interface transfer rate (MB/s)</b>	600
<b>Data transfer rate (MB/s)</b>	up to 185

## 2.5 Physical characteristics

<b>Maximum height</b>	
	<b>6TB</b> 26.1mm / 1.028 in
	<b>3TB</b> 20.20mm / 0.795 in
<b>Maximum width</b>	101.6mm / 4.0 in ( $\pm$ 0.010 in)
<b>Maximum length</b>	146.99mm / 5.787 in
<b>Typical weight</b>	
	<b>6TB</b> 610g / 1.345 lb
	<b>3TB</b> 490g / 1.08 lb
<b>Cache buffer</b>	256MB

## 2.6 Start/stop times

The start/stop times are listed below.

	<b>6TB models</b>	<b>3TB models</b>
Power-on to ready (in seconds)	15 (typical)	10 (typical)
Standby to ready (in seconds)	15 (typical)	10 (typical)
Ready to spindle stop (in seconds)	18 (typical)	12 (typical)

Time-to-ready may be longer than normal if the drive power is removed without going through normal OS powerdown procedures.

## 2.7 Power specifications

The drive receives DC power (+5V or +12V) through a native SATA power connector. Refer to [Figure 1 on page 22](#).

### 2.7.1 Power consumption

Power requirements for the drives are listed in [Table 2](#) and [Table 3](#). Typical power measurements are based on an average of drives tested, under nominal conditions, using 5.0V and 12.0V input voltage at 25°C ambient temperature. These power measurements are done with DIPM enabled.

- Spinup current is measured from the time of power-on to the time that the drive spindle reaches operating speed.
- Operating Power is measured following IDEMA 3 streams standard, assuming CE operating condition
- The drive supports three idle modes: Performance Idle mode, Active Idle mode and Low Power Idle mode. Refer to Section 2.7.4 for power-management mode.

**Table 2 DC power requirements (6TB)**

Power dissipation	Avg (watts 25° C)	Avg 5V typ amps	Avg 12V typ amps
Spinup	—	—	1.8
Idle, Low Power	3.4	0.10	0.242
Operating Power	5.0	0.23	0.321
Standby	0.25	0.04	0.004
Sleep	0.25	0.04	0.004

**Table 3 DC power requirements (3TB)**

Power dissipation	Avg (watts 25° C)	Avg 5V typ amps	Avg 12V typ amps
Spinup	—	—	1.8
Idle, Low Power	2.5	0.12	0.15
Operating Power	3.5	0.24	0.191
Standby	0.25	0.04	0.004
Sleep	0.25	0.04	0.004

## 2.7.2 Conducted noise

Input noise ripple is measured at the host system power supply across an equivalent 80-ohm resistive load on the +12 volt line or an equivalent 15-ohm resistive load on the +5 volt line.

- Using 12-volt power, the drive is expected to operate with a maximum of 120 mV peak-to-peak square-wave injected noise at up to 10MHz.
- Using 5-volt power, the drive is expected to operate with a maximum of 100 mV peak-to-peak square-wave injected noise at up to 10MHz.

<b>Note</b>	Equivalent resistance is calculated by dividing the nominal voltage by the typical RMS read/write current.
-------------	--

## 2.7.3 Voltage tolerance

Voltage tolerance (including noise):

- 5V           ±5%
- 12V         ±10%

## 2.7.4 Power-management modes

The drive provides programmable power management to provide greater energy efficiency. In most systems, users can control power management through the system setup program. The drive features the following power-management modes::

Power modes	Heads	Spindle	Electronics
Active	Tracking	Rotating	Full Power
Idle, Performance	Tracking	Rotating	Full Power
Idle, Active	Floating	Rotating	Partial Power
Idle, Low Power	Parked	Rotating	Partial Power
Standby	Parked	Stopped	Low Power
Sleep	Parked	Stopped	Low Power

- **Active mode**

The drive is in Active mode during the read/write and seek operations.

- **Idle mode**

The electronics remain powered, and the drive accepts all commands and returns to Active mode when disk access is necessary.

- **Standby mode**

The drive enters Standby mode immediately when the host sends a Standby Immediate command. If the host has set the standby timer, the drive enters Standby mode automatically after the drive has been inactive for a specifiable length of time. The standby timer delay is established using a Standby or Idle command. In Standby mode, the electronics are in low power mode, the heads are parked and the spindle is at rest. The drive accepts all commands and returns to Active mode when disk access is necessary.

- **Sleep mode**

The drive enters Sleep mode after receiving a Sleep command from the host. In Sleep mode, the electronics are in low power mode, the heads are parked and the spindle is at rest. The drive leaves Sleep mode after it receives a Hard Reset or Soft Reset from the host. After receiving a reset, the drive exits Sleep mode and enters Standby mode.

- **Idle and Standby timers**

Each time the drive performs an Active function (read, write or seek), the standby timer is reinitialized and begins counting down from its specified delay times to zero. If the standby timer reaches zero before any drive activity is required, the drive makes a transition to Standby mode. In both Idle and Standby mode, the drive accepts all commands and returns to Active mode when disk access is necessary.

## 2.8 Environmental specifications

This section provides the temperature, humidity, shock, and vibration specifications for SkyHawk drives. Ambient temperature is defined as the temperature of the environment immediately surrounding the drive. Above 1000ft. (305 meters), the maximum temperature is derated linearly by 1°C every 1000 ft. Refer to [Section 3.4 on page 23](#) for base plate measurement location.

### 2.8.1 Ambient Temperature

<b>Non-operating (Ambient)</b>	-40° to 70°C (-40° to 158°F)
<b>Operating ambient (min °C)</b>	0° (32°F)
<b>Operating (Drive case max °C)</b>	70° (158°F) †

† Seagate does not recommend operating at sustained case temperatures above 60°C. Operating at higher temperatures will reduce useful life of the product.

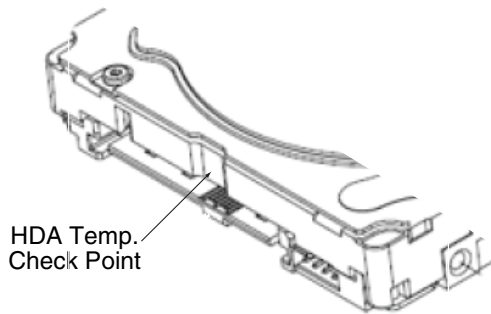

#### Location of the HDA temperature check point

<b>Note</b>	Image is for reference only, may not represent actual drive.
-------------	--

### 2.8.2 Temperature gradient

<b>Operating</b>	20°C per hour (36°F per hour max), without condensation
<b>Non-operating</b>	30°C per hour (54°F per hour max)

### 2.8.3 Humidity

#### 2.8.3.1 Relative humidity

<b>Operating</b>	5% to 90% non-condensing (30% per hour max)
<b>non-operating</b>	5% to 95% non-condensing (30% per hour max)

#### 2.8.3.2 Wet bulb temperature

<b>Operating</b>	30°C / 86°F (rated)
<b>Non-operating</b>	40°C / 104°F (rated)

## 2.8.4 Altitude

<b>Operating</b>	-304m to 3048m (-1000 ft. to 10,000 ft.)
<b>Non-operating</b>	-304m to 12,192m (-1000 ft. to 40,000+ ft.)

## 2.8.5 Shock

All shock specifications assume that the drive is mounted securely with the input shock applied at the drive mounting screws. Shock may be applied in the X, Y or Z axis.

### 2.8.5.1 Operating shock

These drives comply with the performance levels specified in this document when subjected to a maximum operating shock of 80 Gs (read) / 70 Gs (write) based on half-sine shock pulses of 2ms during read operations. Shocks should not be repeated more than two times per second.

### 2.8.5.2 Non-operating shock

The non-operating shock level that the drive can experience without incurring physical damage or degradation in performance when subsequently put into operation is 300 Gs based on a non-repetitive half-sine shock pulse of 2ms duration.

## 2.8.6 Vibration

All vibration specifications assume that the drive is mounted securely with the input vibration applied at the drive mounting screws. Vibration may be applied in the X, Y or Z axis. Throughput may vary if improperly mounted.

### 2.8.6.1 Operating vibration

The maximum vibration levels that the drive may experience while meeting the performance standards specified in this document are specified below.

10Hz to 22Hz	0.25 Gs (Limited displacement)
22Hz to 350Hz	0.50 Gs
350Hz to 500Hz	0.25 Gs

### 2.8.6.2 Non-operating vibration

The maximum non-operating vibration levels that the drive may experience without incurring physical damage or degradation in performance when subsequently put into operation are specified below.

5Hz to 22Hz	3.0 Gs (Limited displacement)
22Hz to 350Hz	3.0 Gs
350Hz to 500Hz	3.0 Gs

## 2.9 Acoustics

Drive acoustics are measured as overall A-weighted acoustic sound power levels (no pure tones). All measurements are consistent with ISO document 7779. Sound power measurements are taken under essentially free-field conditions over a reflecting plane. For all tests, the drive is oriented with the cover facing upward.

<b>Note</b>	For seek mode tests, the drive is placed in seek mode only. The number of seeks per second is defined by the following equation:  (Number of seeks per second = $0.4 / (\text{average latency} + \text{average access time})$ )
-------------	--

**Table 4 Fluid Dynamic Bearing (FDB) motor acoustics**

	Idle*	Seek
<b>6TB models</b>	2.3 bels (typical) 2.5 bels (max)	2.5 bels (typical) 2.6 bels (max)
<b>3TB models</b>	2.1 bels (typical) 2.2 bels (max)	2.3 bels (typical) 2.4 bels (max)

\*During periods of drive idle, some offline activity may occur according to the S.M.A.R.T. specification, which may increase acoustic and power to operational levels.

### 2.9.1 Test for Prominent Discrete Tones (PDTs)

Seagate follows the ECMA-74 standards for measurement and identification of PDTs. An exception to this process is the use of the absolute threshold of hearing. Seagate uses this threshold curve (originated in ISO 389-7) to discern tone audibility and to compensate for the inaudible components of sound prior to computation of tone ratios according to Annex D of the ECMA-74 standards.

## 2.10 Electromagnetic immunity

When properly installed in a representative host system, the drive operates without errors or degradation in performance when subjected to the radio frequency (RF) environments defined in [Table 5](#).

**Table 5 Radio frequency environments**

Test	Description	Performance level	Reference standard
Electrostatic discharge	Contact, HCP, VCP: $\pm 4$ kV; Air: $\pm 8$ kV	B	EN61000-4-2: 95
Radiated RF immunity	80MHz to 1,000MHz, 3 V/m, 80% AM with 1kHz sine 900MHz, 3 V/m, 50% pulse modulation @ 200Hz	A	EN61000-4-3: 96 ENV50204: 95
Electrical fast transient	$\pm 1$ kV on AC mains, $\pm 0.5$ kV on external I/O	B	EN61000-4-4: 95
Surge immunity	$\pm 1$ kV differential, $\pm 2$ kV common, AC mains	B	EN61000-4-5: 95
Conducted RF immunity	150kHz to 80MHz, 3 Vrms, 80% AM with 1kHz sine	A	EN61000-4-6: 97
Voltage dips, interrupts	0% open, 5 seconds 0% short, 5 seconds 40%, 0.10 seconds 70%, 0.01 seconds	C C C B	EN61000-4-11: 94

## 2.11 Warranty

To determine the warranty for a specific drive, use a web browser to access the following web page:

<http://www.seagate.com/support/warranty-and-replacements/>

From this page, click on "Is my Drive under Warranty". Users will be asked to provide the drive serial number, model number (or part number) and country of purchase. The system will display the warranty information for the drive.

### 2.11.1 Data loss under power interruption with write cache enabled

Drive preserves its data during all operations except in cases where power to the drive is interrupted during write operations. This could result in either an uncorrected data error being reported, or the entire sector/track becoming unreadable. This can be permanently recovered by rewriting to the same location on the drive. Additionally any data present in the DRAM buffer will not be written to the disk media, additionally, the drive will not be able to return the original data.

In order to prevent this data loss, the host should issue a standby immediate or flush cache command before a controlled power off operation to the drive.

### 2.11.2 Storage

Maximum storage periods are 180 days within original unopened Seagate shipping package or 60 days unpackaged within the defined non-operating limits (refer to environmental section in this manual). Storage can be extended to 1 year packaged or unpackaged under optimal environmental conditions (25°C, <40% relative humidity non-condensing, and non-corrosive environment). During any storage period the drive non-operational temperature, humidity, wet bulb, atmospheric conditions, shock, vibration, magnetic and electrical field specifications should be followed.

## 2.12 Agency and Safety Certifications

Each Hard Drive and Solid State Drive ("drives") has a product label that includes certifications that are applicable to that specific drive. The following information provides an overview of requirements that may be applicable to the drive.

### 2.12.1 Safety certification

The drives are recognized in accordance with UL/cUL 60950-1 and EN 60950-1.

The following regulatory model numbers represent all features and configurations within the series:

SKR002: 1/2D (3TB Models)

SKR004: 3/4D (6TB Models)

### 2.12.2 European Union (EU) CE Marking Requirements

Drives that display the CE mark comply with the European Union (EU) requirements specified in the Electromagnetic Compatibility Directive (2014/30/EU) put into force on 20 April 2016. Testing is performed to the levels specified by the product standards for Information Technology Equipment (ITE). Emission levels are defined by EN 55032:2012, Class B and the immunity levels are defined by EN 55024:2010.

The drives also meet the requirements of The Low Voltage Directive (LVD) 2014/35/EU.

Seagate drives are tested in representative end-user systems. Although CE-marked Seagate drives comply with all relevant regulatory requirements and standards for the drives, Seagate cannot guarantee that all system-level products into which the drives are installed comply with all regulatory requirements and standards applicable to the system-level products. The drive is designed for operation inside a properly designed system (e.g., enclosure designed for the drive), with properly shielded I/O cable (if necessary) and terminators on all unused I/O ports. Computer manufacturers and system integrators should confirm EMC compliance and provide CE marking for the system-level products.

For compliance with the RoHS "Recast" Directive 2011/65/EU (RoHS 2), [See Section 2.13.1 on page 19](#).

### 2.12.3 Australian RCM Compliance Mark

If these models have the RCM marking, they comply with the Australia/New Zealand Standard AS/NZ CISPR32 and meet the Electromagnetic Compatibility (EMC) Framework requirements of the Australian Communication and Media Authority (ACMA).

### 2.12.4 Canada ICES-003

If this model has the ICES-003:2016 marking it complies with requirements of ICES tested per ANSI C63.4-2014.

### 2.12.5 South Korean KC Certification Mark

The South Korean KC Certification Mark means the drives comply with paragraph 1 of Article 11 of the Electromagnetic Compatibility control Regulation and meet the Electromagnetic Compatibility (EMC) Framework requirements of the Radio Research Agency (RRA) Communications Commission, Republic of Korea. These drives have been tested and comply with the Electromagnetic Interference/Electromagnetic Susceptibility (EMI/EMS) for Class B products. Drives are tested in a representative, end-user system by a Korean-recognized lab.

기종별	사용자안내문
B급 기기 (가정용 방송통신기자재)	이 기기는 가정용(B급) 전자파적합기기로서 주로 가정에서 사용하는 것을 목적으로 하며, 모든 지역에서 사용할 수 있습니다.

### 2.12.6 Morocco Commodity Mark

To satisfy our OEM customers, Seagate has added the Moroccan Commodity Mark to the drives provided to the OEM for the sale of Customer Kits produced by our OEM customers that are intended to be incorporated into the OEM's finished system-level product by an end user. The Customer Kits are considered 'devices' under Morocco's Order of the Minister of Industry, Trade, Investment and Digital Economy No. 2574-14 of 29 Ramadan 1436 (16 July 2015) on electromagnetic compatibility of equipment.

Seagate drives are tested for compliance and complies with the European Union (EU) Electromagnetic Compatibility (EMC) Directive 2014/30/EU and the Low Voltage Directive (LVD) 2014/35/EU. Accordingly, the drives also meets the requirements of Morocco's Order of the Minister of Industry, Trade, Investment and Digital Economy No. 2574-14 of 29 Ramadan 1436 (16 July 2015) on electromagnetic compatibility of equipment.

### 2.12.7 Taiwanese BSMI

Drives with the Taiwanese certification mark comply with Chinese National Standard, CNS13438.

For compliance with the Taiwan Bureau of Standards, Metrology and Inspection's (BSMI) requirements, [See Section 2.13.3 on page 21](#).

### 2.12.8 FCC verification

These drives are intended to be contained solely within a personal computer or similar enclosure (not attached as an external device). As such, each drive is considered to be a subassembly even when it is individually marketed to the customer. As a subassembly, no Federal Communications Commission verification or certification of the device is required.

Seagate has tested this device in enclosures as described above to ensure that the total assembly (enclosure, disk drive, motherboard, power supply, etc.) does comply with the limits for a Class B computing device, pursuant to Subpart J, Part 15 of the FCC rules. Operation with noncertified assemblies is likely to result in interference to radio and television reception.

**Radio and television interference.** This equipment generates and uses radio frequency energy and if not installed and used in strict accordance with the manufacturer's instructions, may cause interference to radio and television reception.

This equipment is designed to provide reasonable protection against such interference in a residential installation. However, there is no guarantee that interference will not occur in a particular installation. If this equipment does cause interference to radio or television, which can be determined by turning the equipment on and off, users are encouraged to try one or more of the following corrective measures:

- Reorient the receiving antenna.
- Move the device to one side or the other of the radio or TV.
- Move the device farther away from the radio or TV.
- Plug the computer into a different outlet so that the receiver and computer are on different branch outlets.

If necessary, users should consult a dealer or an experienced radio/television technician for additional suggestions. Users may find helpful the following booklet prepared by the Federal Communications Commission: *How to Identify and Resolve Radio-Television Interference Problems*. This booklet is available from the Superintendent of Documents, U.S. Government Printing Office, Washington, DC 20402. Refer to publication number 004-000-00345-4.

## 2.13 Environmental protection

Seagate designs its products to meet environmental protection requirements worldwide, including regulations restricting certain chemical substances.

### 2.13.1 European Union Restriction of Hazardous Substance Law

#### 2.13.1.1 Restriction of Hazardous Substances in Electrical and Electronic Equipment

Seagate drives are designed to be compliant with the European Union RoHS "Recast" Directive 2011/65/EU (RoHS 2) as amended by Directive (EU) 2015/863. The RoHS2 restricts the use of certain hazardous substances such as Lead, Cadmium, Mercury, Hexavalent Chromium, Polybrominated Biphenyls (PBB) and Polybrominated Diphenyl Ether (PBDE), BisBis(2-Ethylhexyl) phthalate (DEHP), Benzyl butyl phthalate (BBP), Dibutyl phthalate (DBP), and Diisobutyl phthalate (DIBP) in electrical and electronic equipment (EEE).

### 2.13.1.2 Substances of Very High Concern (SVHC)

The European Union REACH (Registration, Evaluation, Authorization and Restriction of Chemicals) Regulation (EC) 1907/2006 regulates chemicals shipped into and used in Europe. A number of parts and materials in Seagate products are procured from external suppliers. We rely on the representations of our suppliers regarding the presence of REACH substances in these articles and materials. Our supplier contracts require compliance with our chemical substance restrictions, and our suppliers document their compliance with our requirements by providing full-disclosure material content declarations that disclose inclusion of any REACH-regulated substance in such articles or materials. Product-specific REACH declarations are available upon request through your Seagate Sales Representative.

### 2.13.2 China Requirements —China RoHS 2



China RoHS 2 refers to the Ministry of Industry and Information Technology Order No. 32, effective July 1, 2016, titled Management Methods for the Restriction of the Use of Hazardous Substances in Electrical and Electronic Products. To comply with China RoHS 2, Seagate determines this product's Environmental Protection Use Period (EPUP) to be 20 years in accordance with the *Marking for the Restricted Use of Hazardous Substances in Electronic and Electrical Products*, SJ/T 11364-2014.

**Table 6 China - Hazardous Substances**

部件名称 Part Name	有害物质 Hazardous Substances					
	铅 (Pb)	汞 (Hg)	镉 (Cd)	六价铬 (Cr <sup>+6</sup> )	多溴联苯 (PBB)	多溴二苯醚 (PBDE)
硬盘驱动器 HDD	X	O	O	O	O	O
印刷电路板组装 PCBA	X	O	O	O	O	O

本表格依据 SJ/T 11364 的规定编制。

This table is prepared in accordance with the provisions of SJ/T 11364-2014

O: 表示该有害物质在该部件所有均质材料中的含量均在 GB/T 26572 规定的限量要求以下。

O: Indicates that the hazardous substance contained in all of the homogeneous materials for this part is below the limit requirement of GB/T26572.

X: 表示该有害物质至少在该部件的某一均质材料中的含量超出 GB/T 26572 规定的限量要求。

X: Indicates that the hazardous substance contained in at least one of the homogeneous materials used for this part is above the limit requirement of GB/T26572.

### 2.13.3 Taiwan Requirements — Taiwan RoHS

Taiwan RoHS refers to the Taiwan Bureau of Standards, Metrology and Inspection's (BSMI) requirements in standard CNS 15663, Guidance to reduction of the restricted chemical substances in electrical and electronic equipment. Seagate products must comply with the "Marking of presence" requirements in Section 5 of CNS 15663, effective January 1, 2018. This product is Taiwan RoHS compliant.

The following table meets the Section 5 "Marking of presence" requirements.

**Table 7 Taiwan - Restricted Substances**

設備名稱：硬盤設備，型號：僅適用於內部使用 Equipment Name: Hard Disk Device, Type Designation: Internal Use Only						
單元 Unit	限用物質及其化學符號 Restricted Substance and its chemical symbol					
	鉛 (Pb)	汞 (Hg)	鎘 (Cd)	六價鉻 (Cr <sup>+6</sup> )	多溴聯苯 (PBB)	多溴二苯醚 (PBDE)
硬盤驅動器 HDD	—	0	0	0	0	0
印刷電路板組裝 PCBA	—	0	0	0	0	0
備考 1. "0" 係指該項限用物質之百分比含量未超出百分比含量基準值。 Note 1. "0" indicates that the percentage content of the restricted substance does not exceed the percentage of reference value of presence. 備考 2. "—" 係指該項限用物質為排除項目。 Note 2. "—" indicates that the restricted substance corresponds to the exemption.						

### 2.14 Corrosive environment

Seagate electronic drive components pass accelerated corrosion testing equivalent to 10 years exposure to light industrial environments containing sulfurous gases, chlorine and nitric oxide, classes G and H per ASTM B845. However, this accelerated testing cannot duplicate every potential application environment. Users should use caution exposing any electronic components to uncontrolled chemical pollutants and corrosive chemicals as electronic drive component reliability can be affected by the installation environment. The silver, copper, nickel and gold films used in Seagate products are especially sensitive to the presence of sulfide, chloride, and nitrate contaminants. Sulfur is found to be the most damaging. In addition, electronic components should never be exposed to condensing water on the surface of the printed circuit board assembly (PCBA) or exposed to an ambient relative humidity greater than 95%. Materials used in cabinet fabrication, such as vulcanized rubber, that can outgas corrosive compounds should be minimized or eliminated. The useful life of any electronic equipment may be extended by replacing materials near circuitry with sulfide-free alternatives.

## 3.0 Configuring and Mounting the Drive

This section contains the specifications and instructions for configuring and mounting the drive.

### 3.1 Handling and static-discharge precautions

After unpacking, and before installation, the drive may be exposed to potential handling and electrostatic discharge (ESD) hazards. Observe the following standard handling and static-discharge precautions:

#### Caution

- Before handling the drive, put on a grounded wrist strap, or ground oneself frequently by touching the metal chassis of a computer that is plugged into a grounded outlet. Wear a grounded wrist strap throughout the entire installation procedure.
- Handle the drive by its edges or frame *only*.
- The drive is extremely fragile—handle it with care. Do not press down on the drive top cover.
- Always rest the drive on a padded, antistatic surface until users mount it in the computer.
- Do not touch the connector pins or the printed circuit board.
- Do not remove the factory-installed labels from the drive or cover them with additional labels. Removal voids the warranty. Some factory-installed labels contain information needed to service the drive. Other labels are used to seal out dirt and contamination.

### 3.2 Configuring the drive

Each drive on the SATA interface connects point-to-point with the SATA host adapter. There is no master/slave relationship because each drive is considered a master in a point-to-point relationship. If two drives are attached on one SATA host adapter, the host operating system views the two devices as if they were both “masters” on two separate ports. Both drives behave as if they are Device 0 (master) devices.

SATA drives are designed for easy installation. It is usually not necessary to set any jumpers on the drive for proper operation; however, if users connect the drive and receive a “drive not detected” error, the SATA-equipped motherboard or host adapter may use a chipset that does not support SATA speed autonegotiation.

### 3.3 SATA cables and connectors

The SATA interface cable consists of four conductors in two differential pairs, plus three ground connections. The cable size may be 30 to 26 AWG with a maximum length of one meter (39.37 inches). See [Table 8](#) for connector pin definitions. Either end of the SATA signal cable can be attached to the drive or host.

For direct backplane connection, the drive connectors are inserted directly into the host receptacle. The drive and the host receptacle incorporate features that enable the direct connection to be hot pluggable and blind mateable.

For installations which require cables, users can connect the drive as illustrated in [Figure 1](#).

**Figure 1** Attaching SATA cabling

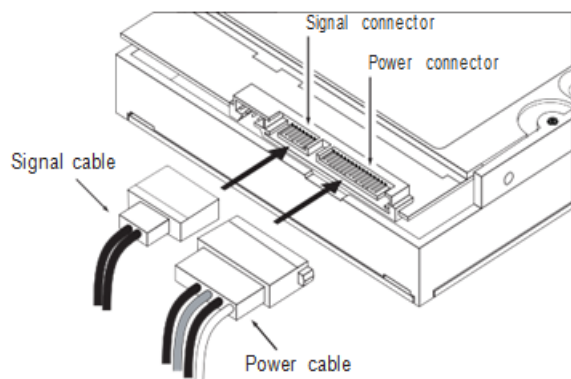

Each cable is keyed to ensure correct orientation. SkyHawk drives support latching SATA connectors.

### 3.4 Drive mounting

Users can mount the drive in any orientation using four screws in the side-mounting holes or four screws in the bottom-mounting holes. Refer to **Figure 2** for drive mounting dimensions. Follow these important mounting precautions when mounting the drive:

- Allow a minimum clearance of 0.030 inches (0.76mm) around the entire perimeter of the drive for cooling.
- Use only 6-32 UNC mounting screws.
- The screws should be inserted no more than 0.140 inch (3.56mm) into the bottom or side mounting holes.
- Do not overtighten the mounting screws (maximum torque: 6 inch-lb).

**Figure 2 Mounting dimensions (3TB models)**

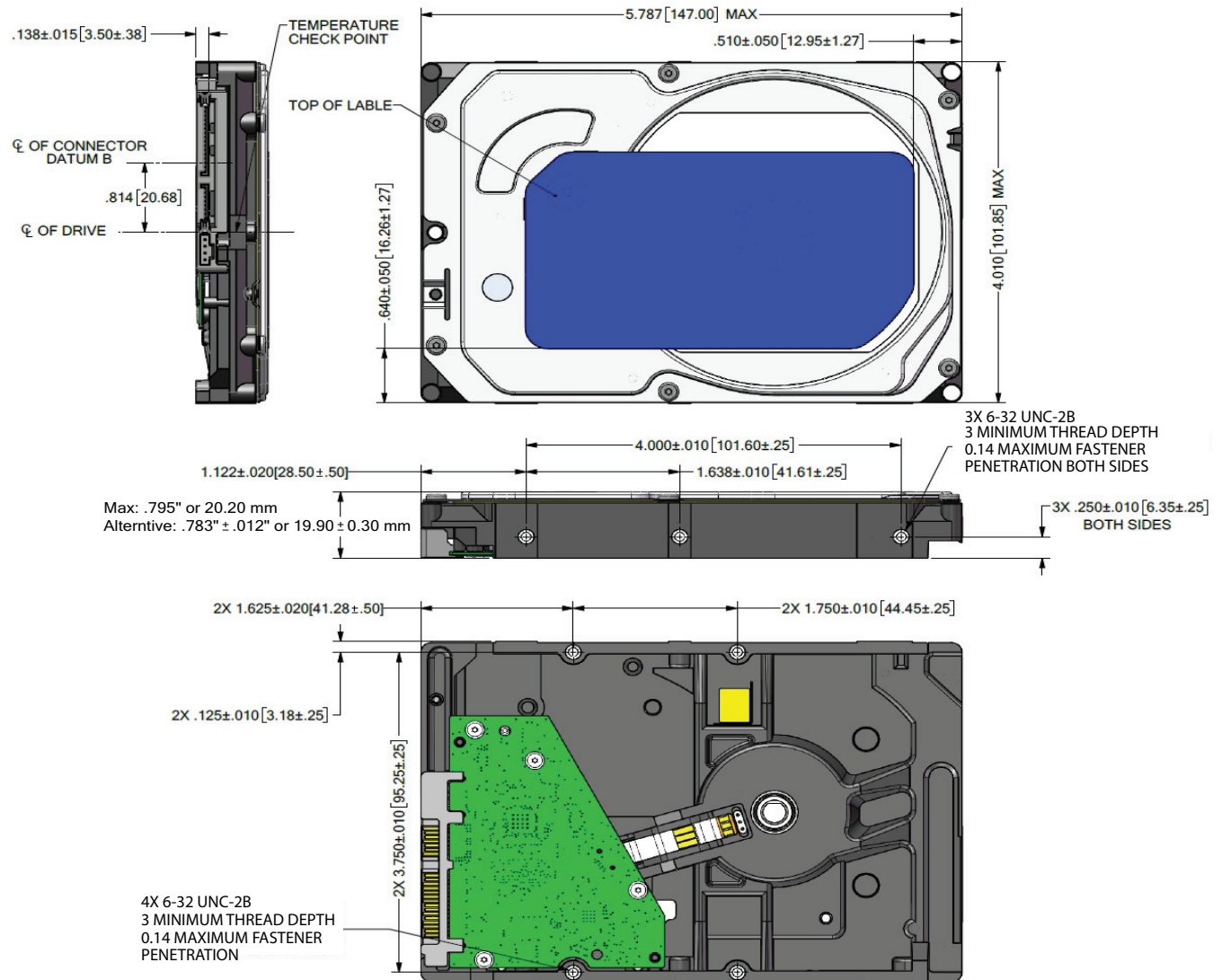
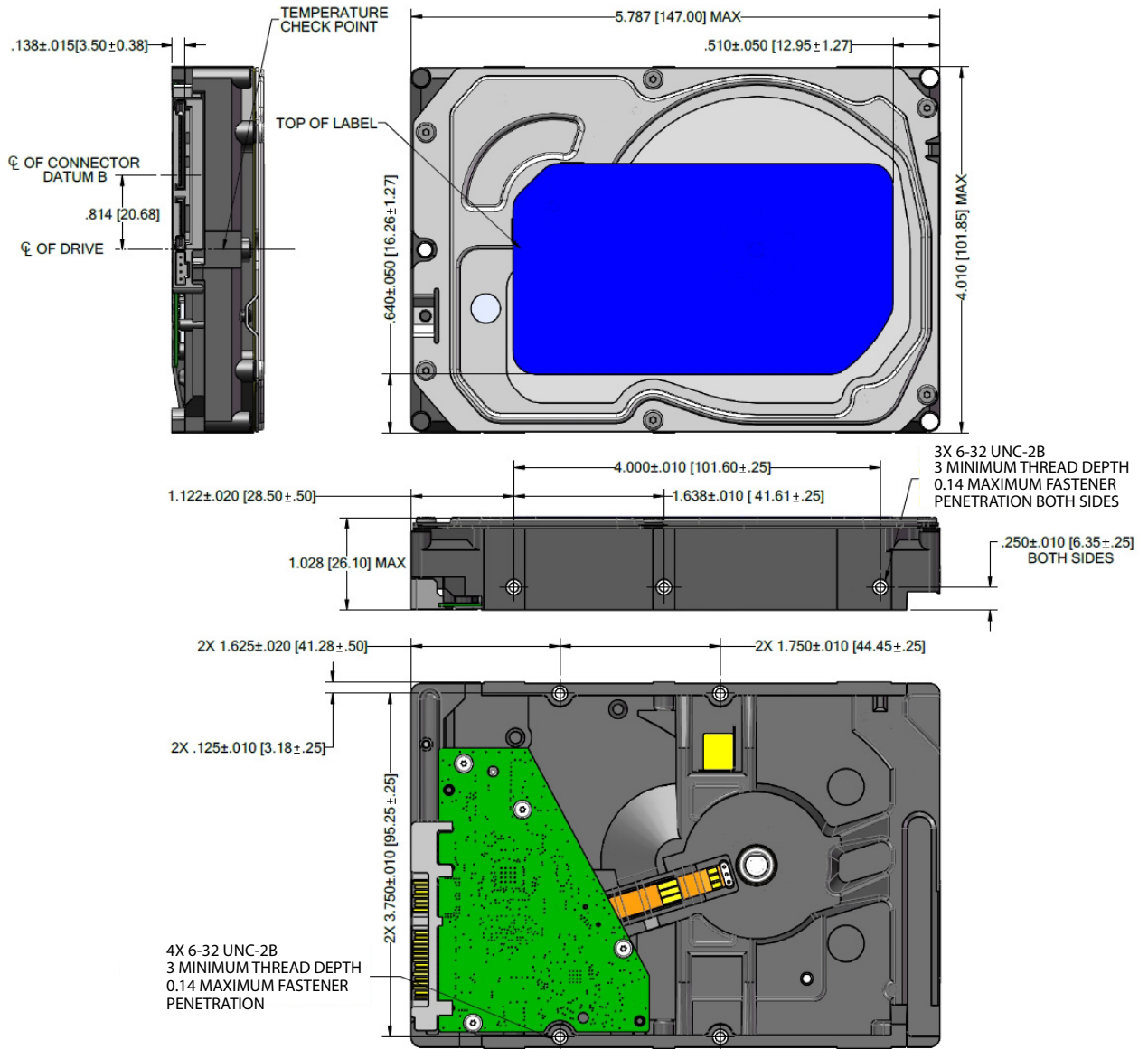

Figure 3 Mounting dimensions (6TB models)



## 4.0 SATA Interface

These drives use the industry-standard Serial ATA (SATA) interface that supports FIS data transfers. It supports ATA programmed input/output (PIO) modes 0 to 4; multiword DMA modes 0 to 2, and Ultra DMA modes 0 to 6.

For detailed information about the SATA interface, refer to the “Serial ATA: High Speed Serialized AT Attachment” specification.

### 4.1 Hot-Plug compatibility

SkyHawk drives incorporate connectors which enable users to hot plug these drives in accordance with the SATA Revision 3.2 specification. This specification can be downloaded from [www.serialata.org](http://www.serialata.org).

### 4.2 SATA device plug connector pin definitions

**Table 8** summarizes the signals on the SATA interface and power connectors.

**Table 8** SATA connector pin definitions

Segment	Pin	Function	Definition
Signal	S1	Ground	2nd mate
	S2	A+	Differential signal pair A from Phy
	S3	A-	
	S4	Ground	2nd mate
	S5	B-	Differential signal pair B from Phy
	S6	B+	
	S7	Ground	2nd mate
<b>Key and spacing separate signal and power segments</b>			
Power	P1	V <sub>33</sub>	3.3V power
	P2	V <sub>33</sub>	3.3V power
	P3	V <sub>33</sub>	3.3V power, pre-charge, 2nd mate
	P4	Ground	1st mate
	P5	Ground	2nd mate
	P6	Ground	2nd mate
	P7	V <sub>5</sub>	5V power, pre-charge, 2nd mate
	P8	V <sub>5</sub>	5V power
	P9	V <sub>5</sub>	5V power
	P10	Ground	2nd mate
	P11	Ground or LED signal	If grounded, drive does not use deferred spin
	P12	Ground	1st mate.
	P13	V <sub>12</sub>	12V power, pre-charge, 2nd mate
	P14	V <sub>12</sub>	12V power
	P15	V <sub>12</sub>	12V power

#### Notes

- All pins are in a single row, with a 1.27 mm (0.050 in) pitch.
- The comments on the mating sequence apply to the case of backplane blindmate connector only. In this case, the mating sequences are:
  - the ground pins P4 and P12.
  - the pre-charge power pins and the other ground pins.
  - the signal pins and the rest of the power pins.
- There are three power pins for each voltage. One pin from each voltage is used for pre-charge when installed in a blind-mate backplane configuration.
  - All used voltage pins (V<sub>x</sub>) must be terminated.

### 4.3 Supported ATA commands

The following table lists SATA standard commands that the drive supports.

For a detailed description of the ATA commands, refer to the Serial ATA International Organization: Serial ATA Revision 3.0 (<http://www.sata-io.org>).

See “S.M.A.R.T. commands” on page 34 for details and subcommands used in the S.M.A.R.T. implementation.

**Table 9** SATA standard commands

Command name	Command code (in hex)
Check Power Mode	E5 <sub>H</sub>
Device Configuration Freeze Lock	B1 <sub>H</sub> / C1 <sub>H</sub>
Device Configuration Identify	B1 <sub>H</sub> / C2 <sub>H</sub>
Device Configuration Restore	B1 <sub>H</sub> / C0 <sub>H</sub>
Device Configuration Set	B1 <sub>H</sub> / C3 <sub>H</sub>
Device Reset	08 <sub>H</sub>
Download Microcode	92 <sub>H</sub>
Execute Device Diagnostics	90 <sub>H</sub>
Flush Cache	E7 <sub>H</sub>
Flush Cache Extended	EA <sub>H</sub>
Format Track	50 <sub>H</sub>
Identify Device	EC <sub>H</sub>
Idle	E3 <sub>H</sub>
Idle Immediate	E1 <sub>H</sub>
Initialize Device Parameters	91 <sub>H</sub>
Read Buffer	E4 <sub>H</sub>
Read DMA	C8 <sub>H</sub>
Read DMA Extended	25 <sub>H</sub>
Read DMA Without Retries	C9 <sub>H</sub>
Read Log Ext	2F <sub>H</sub>
Read Multiple	C4 <sub>H</sub>
Read Multiple Extended	29 <sub>H</sub>
Read Native Max Address	F8 <sub>H</sub>
Read Native Max Address Extended	27 <sub>H</sub>
Read Sectors	20 <sub>H</sub>
Read Sectors Extended	24 <sub>H</sub>
Read Sectors Without Retries	21 <sub>H</sub>
Read Verify Sectors	40 <sub>H</sub>
Read Verify Sectors Extended	42 <sub>H</sub>
Read Verify Sectors Without Retries	41 <sub>H</sub>
Recalibrate	10 <sub>H</sub>
Security Disable Password	F6 <sub>H</sub>
Security Erase Prepare	F3 <sub>H</sub>
Security Erase Unit	F4 <sub>H</sub>
Security Freeze	F5 <sub>H</sub>
Security Set Password	F1 <sub>H</sub>
Security Unlock	F2 <sub>H</sub>

**Table 9 SATA standard commands (continued)**

Command name	Command code (in hex)	
Seek	70 <sub>H</sub>	
Set Features	EF <sub>H</sub>	
Set Max Address	F9 <sub>H</sub>	
Note: Individual Set Max Address commands are identified by the value placed in the Set Max Features register as defined to the right.	Address:	00H
	Password:	01H
	Lock:	02H
	Unlock:	03H
	Freeze Lock:	04H
Set Max Address Extended	37 <sub>H</sub>	
Set Multiple Mode	C6 <sub>H</sub>	
Sleep	E6 <sub>H</sub>	
S.M.A.R.T. Disable Operations	B0 <sub>H</sub> / D9 <sub>H</sub>	
S.M.A.R.T. Enable/Disable Autosave	B0 <sub>H</sub> / D2 <sub>H</sub>	
S.M.A.R.T. Enable Operations	B0 <sub>H</sub> / D8 <sub>H</sub>	
S.M.A.R.T. Execute Offline	B0 <sub>H</sub> / D4 <sub>H</sub>	
S.M.A.R.T. Read Attribute Thresholds	B0 <sub>H</sub> / D1 <sub>H</sub>	
S.M.A.R.T. Read Data	B0 <sub>H</sub> / D0 <sub>H</sub>	
S.M.A.R.T. Read Log Sector	B0 <sub>H</sub> / D5 <sub>H</sub>	
S.M.A.R.T. Return Status	B0 <sub>H</sub> / DA <sub>H</sub>	
S.M.A.R.T. Save Attribute Values	B0 <sub>H</sub> / D3 <sub>H</sub>	
S.M.A.R.T. Write Log Sector	B0 <sub>H</sub> / D6 <sub>H</sub>	
Standby	E2 <sub>H</sub>	
Standby Immediate	E0 <sub>H</sub>	
Write Buffer	E8 <sub>H</sub>	
Write DMA	CA <sub>H</sub>	
Write DMA Extended	35 <sub>H</sub>	
Write DMA FUA Extended	3D <sub>H</sub>	
Write DMA Without Retries	CB <sub>H</sub>	
Write Log Extended	3F <sub>H</sub>	
Write Multiple	C5 <sub>H</sub>	
Write Multiple Extended	39 <sub>H</sub>	
Write Multiple FUA Extended	CE <sub>H</sub>	
Write Sectors	30 <sub>H</sub>	
Write Sectors Without Retries	31 <sub>H</sub>	
Write Sectors Extended	34 <sub>H</sub>	
Write Uncorrectable	45 <sub>H</sub>	

### 4.3.1 Identify Device command

The Identify Device command (command code EC<sub>H</sub>) transfers information about the drive to the host following power up. The data is organized as a single 512-byte block of data, whose contents are shown in on page 26. All reserved bits or words should be set to zero. Parameters listed with an “x” are drive-specific or vary with the state of the drive.

The following commands contain drive-specific features that may not be included in the SATA specification.

**Table 10 Identify Device commands**

Word	Description	Value
0	Configuration information: <ul style="list-style-type: none"> <li>• Bit 15: 0 = ATA; 1 = ATAPI</li> <li>• Bit 7: removable media</li> <li>• Bit 6: removable controller</li> <li>• Bit 0: reserved</li> </ul>	0C5A <sub>H</sub>
1	Number of logical cylinders	16,383
2	Specific configuration: <p>37C8h Device requires SET FEATURES subcommand to spin-up after power-up and IDENTIFY DEVICE data is incomplete.</p> <p>738Ch Device requires SET FEATURES subcommand to spin-up after power-up and IDENTIFY DEVICE data is complete.</p> <p>8C73h Device does not require SET FEATURES subcommand to spin-up after power-up and IDENTIFY DEVICE data is incomplete.</p> <p>C837h Device does not require SET FEATURES subcommand to spin-up after power-up and IDENTIFY DEVICE data is complete.</p>	C837 <sub>H</sub>
3	Number of logical heads	16
4	Retired	0000 <sub>H</sub>
5	Retired	0000 <sub>H</sub>
6	Number of logical sectors per logical track: 63	003F <sub>H</sub>
7–9	Retired	0000 <sub>H</sub>
10–19	Serial number: (20 ASCII characters, 0000 <sub>H</sub> = none)	ASCII
20	Retired	0000 <sub>H</sub>
21	Retired	0400 <sub>H</sub>
22	Obsolete	0000 <sub>H</sub>
23–26	Firmware revision (8 ASCII character string, padded with blanks to end of string)	x.xx
27–46	Drive model number: (40 ASCII characters, padded with blanks to end of string)	
47	(Bits 7–0) Maximum sectors per interrupt on Read multiple and Write multiple (16)	8010 <sub>H</sub>
48	Trusted Computing feature set options: <ul style="list-style-type: none"> <li>15 Shall be cleared to zero</li> <li>14 Shall be set to one</li> <li>13:1 Reserved for the Trusted Computing Group</li> <li>0 Trusted Computing feature set is supported</li> </ul>	4000 <sub>H</sub>
49	Standard Standby timer, IORDY supported and may be disabled	2F00 <sub>H</sub>
50	Capabilities: (see 7.17.7.17) <ul style="list-style-type: none"> <li>15 Shall be cleared to zero</li> <li>14 Shall be set to one</li> <li>13:2 Reserved</li> <li>1 Obsolete</li> <li>0 Shall be set to one to indicate a vendor specific Standby timer value minimum</li> </ul>	4000 <sub>H</sub>

**Table 10 Identify Device commands (continued)**

Word	Description	Value
51	PIO data-transfer cycle timing mode	0200 <sub>H</sub>
52	Retired (Obsolete)	0200 <sub>H</sub>
53	15:8 Free-fall Control Sensitivity 7:3 Reserved 2 the fields reported in word 88 are valid 1 the fields reported in words (70:64) are valid 0 Obsolete	0007 <sub>H</sub>
54	Number of current logical cylinders (Obsolete)	xxxx <sub>H</sub>
55	Number of current logical heads (Obsolete)	xxxx <sub>H</sub>
56	Number of current logical sectors per logical track (Obsolete)	xxxx <sub>H</sub>
57–58	Current capacity in sectors (Obsolete)	xxxx <sub>H</sub>
59	15 The BLOCK ERASE EXT command is supported 14 The OVERWRITE EXT command is supported 13 The CRYPTO SCRAMBLE EXT command is supported 12 The Sanitize feature set is supported 11:9 Reserved 8 Multiple logical sector setting is valid 7:0 Current setting for number of logical sectors that shall be transferred per DRQ data block on READ/WRITE Multiple commands	5C10 <sub>H</sub>
60–61	Total number of user-addressable LBA sectors available (see Section 2.2 for related information) *Note: The maximum value allowed in this field is: 0FFFFFFFh (268,435,455 sectors, 137GB). Drives with capacities over 137GB will have 0FFFFFFFh in this field and the actual number of user-addressable LBAs specified in words 100-103. This is required for drives that support the 48-bit addressing feature.	0FFFFFFFh*
62	Obsolete	0000 <sub>H</sub>
63	Multiword DMA active and modes supported (see note following this table)	xx07 <sub>H</sub>
64	Advanced PIO modes supported (modes 3 and 4 supported)	0003 <sub>H</sub>
65	Minimum multiword DMA transfer cycle time per word (120 nsec)	0078 <sub>H</sub>
66	Recommended multiword DMA transfer cycle time per word (120 nsec)	0078 <sub>H</sub>
67	Minimum PIO cycle time without IORDY flow control (240 nsec)	0078 <sub>H</sub>
68	Minimum PIO cycle time with IORDY flow control (120 nsec)	0078 <sub>H</sub>
69	Additional Supported 15 CFAST Specification Support 14 Deterministic data in trimmed LBA range(s) is supported 13 Long Physical Sector Alignment Error Reporting Control is supported 12 Obsolete 11 READ BUFFER DMA is supported 10 WRITE BUFFER DMA is supported 9 Obsolete 8 DOWNLOAD MICROCODE DMA is supported 7 Reserved for IEEE 1667 6 0 = Optional ATA device 28-bit commands supported 5 Trimmed LBA range(s) returning zeroed data is supported 4 Device Encrypts All User Data 3 Extended Number of User Addressable Sectors is supported 2 All write cache is non-volatile 1:0 Reserved	0000 <sub>H</sub>

**Table 10 Identify Device commands (continued)**

Word	Description	Value
70–74	ATA-reserved	0000 <sub>H</sub>
75	Queue depth	001F <sub>H</sub>
76	SATA capabilities	xxxx <sub>H</sub>
77	Reserved for future SATA definition	xxxx <sub>H</sub>
78	SATA features supported	xxxx <sub>H</sub>
79	SATA features enabled	xxxx <sub>H</sub>
80	Major version number	07F0 <sub>H</sub>
81	Minor version number	006D <sub>H</sub>
82	Command sets supported	306B <sub>H</sub>
83	Command sets supported	7561 <sub>H</sub>
84	Command sets support extension (see note following this table)	6173 <sub>H</sub>
85	Command sets enabled	30xx <sub>H</sub>
86	Command sets enabled	B441 <sub>H</sub>
87	Command sets enable extension	6173 <sub>H</sub>
88	Ultra DMA support and current mode (see note following this table)	xx7F <sub>H</sub>
89	Security erase time	xxxx <sub>H</sub>
90	Enhanced security erase time	xxxx <sub>H</sub>
92	Master password revision code	FFFE <sub>H</sub>
93	Hardware reset value	xxxx <sub>H</sub>
94	Automatic acoustic management	D0D0 <sub>H</sub>
95–99	ATA-reserved	0000 <sub>H</sub>
100–103	Total number of user-addressable LBA sectors available (see Section 2.2 for related information). These words are required for drives that support the 48-bit addressing feature. Maximum value: 0000FFFFFFFF <sub>H</sub> .	ST6000VX001 = 11,721,045,168 ST3000VX009 = 5,860,533,168
104-105	ATA-reserved	0000 <sub>H</sub>
106	Physical sector size / logical sector size	6003 <sub>H</sub>
107	ATA-reserved	0000 <sub>H</sub>
108-111	The mandatory value of the world wide name (WWN) for the drive. <b>NOTE:</b> This field is valid if word 84, bit 8 is set to 1 indicating 64-bit WWN support.	Each drive will have a unique value.
112-118	ATA-reserved	0000 <sub>H</sub>
119	Commands and feature sets supported	41DE <sub>H</sub>
120	Commands and feature sets supported or enabled	409C <sub>H</sub>
121-127	ATA-reserved	0000 <sub>H</sub>
128	Security status	0021 <sub>H</sub>
129–159	Seagate-reserved	xxxx <sub>H</sub>
160–167	ATA-reserved	0000 <sub>H</sub>
168	Device Nominal Form Factor	0002 <sub>H</sub>
169-205	ATA-reserved	0000 <sub>H</sub>

**Table 10 Identify Device commands (continued)**

Word	Description	Value
206	SCT Command Transport	10A5 <sub>H</sub>
207-208	ATA-reserved	0000 <sub>H</sub>
209	Alignment of logical blocks within a physical block	4000 <sub>H</sub>
210-216	ATA-reserved	0000 <sub>H</sub>
217	Nominal media rotation rate	175C <sub>H</sub>
218-221	ATA-reserved	0000 <sub>H</sub>
222	Transport major version number	107F <sub>H</sub>
223-229	ATA-reserved	0000 <sub>H</sub>
230-233	Extended Number of User Addressable Sectors	ST6000VX001 = 11,721,045,168 ST3000VX009 = 5,860,533,168
234-254	ATA-reserved	0000 <sub>H</sub>
255	Integrity word	xxA5 <sub>H</sub>

<b>Note</b>	Advanced Power Management (APM) and Automatic Acoustic Management (AAM) features are not supported.
-------------	---

<b>Note</b>	See the bit descriptions below for words 63, 84, and 88 of the Identify Drive data.
-------------	---

<b>Description (if bit is set to 1)</b>	
	<b>Bit      Word 63</b>
0	Multiword DMA mode 0 is supported.
1	Multiword DMA mode 1 is supported.
2	Multiword DMA mode 2 is supported.
8	Multiword DMA mode 0 is currently active.
9	Multiword DMA mode 1 is currently active.
10	Multiword DMA mode 2 is currently active.
	<b>Bit      Word 84</b>
0	SMART error login is supported.
1	SMART self-test is supported.
2	Media serial number is supported.
3	Media Card Pass Through Command feature set is supported.
4	Streaming feature set is supported.
5	GPL feature set is supported.
6	WRITE DMA FUA EXT and WRITE MULTIPLE FUA EXT commands are supported.
7	WRITE DMA QUEUED FUA EXT command is supported.
8	64-bit World Wide Name is supported.
9-10	Obsolete.
11-12	Reserved for TLC.
13	IDLE IMMEDIATE command with IUNLOAD feature is supported.
14	Shall be set to 1.
15	Shall be cleared to 0.
	<b>Bit      Word 88</b>
0	Ultra DMA mode 0 is supported.
1	Ultra DMA mode 1 is supported.
2	Ultra DMA mode 2 is supported.
3	Ultra DMA mode 3 is supported.
4	Ultra DMA mode 4 is supported.
5	Ultra DMA mode 5 is supported.
6	Ultra DMA mode 6 is supported.
8	Ultra DMA mode 0 is currently active.
9	Ultra DMA mode 1 is currently active.
10	Ultra DMA mode 2 is currently active.
11	Ultra DMA mode 3 is currently active.
12	Ultra DMA mode 4 is currently active.
13	Ultra DMA mode 5 is currently active.
14	Ultra DMA mode 6 is currently active.

### 4.3.2 Set Features command

This command controls the implementation of various features that the drive supports. When the drive receives this command, it sets BSY, checks the contents of the Features register, clears BSY and generates an interrupt. If the value in the register does not represent a feature that the drive supports, the command is aborted. Power-on default has the read look-ahead and write caching features enabled. The acceptable values for the Features register are defined as follows:

**Table 11 Set Features command**

02 <sub>H</sub>	Enable write cache ( <i>default</i> )
03 <sub>H</sub>	Set transfer mode (based on value in Sector Count register) Sector Count register values:
	00 <sub>H</sub> Set PIO mode to default (PIO mode 2)
	01 <sub>H</sub> Set PIO mode to default and disable IORDY (PIO mode 2)
	08 <sub>H</sub> PIO mode 0
	09 <sub>H</sub> PIO mode 1
	0A <sub>H</sub> PIO mode 2
	0B <sub>H</sub> PIO mode 3
	0C <sub>H</sub> PIO mode 4 ( <i>default</i> )
	20 <sub>H</sub> Multiword DMA mode 0
	21 <sub>H</sub> Multiword DMA mode 1
	22 <sub>H</sub> Multiword DMA mode 2
	40 <sub>H</sub> Ultra DMA mode 0
	41 <sub>H</sub> Ultra DMA mode 1
	42 <sub>H</sub> Ultra DMA mode 2
	43 <sub>H</sub> Ultra DMA mode 3
	44 <sub>H</sub> Ultra DMA mode 4
	45 <sub>H</sub> Ultra DMA mode 5
	46 <sub>H</sub> Ultra DMA mode 6
06 <sub>H</sub>	Enable the PUIS feature set
07 <sub>H</sub>	PUIS feature set device spin-up
10 <sub>H</sub>	Enable use of SATA features
55 <sub>H</sub>	Disable read look-ahead (read cache) feature
82 <sub>H</sub>	Disable write cache
86 <sub>H</sub>	Disable the PUIS feature set
90 <sub>H</sub>	Disable use of SATA features
AA <sub>H</sub>	Enable read look-ahead (read cache) feature ( <i>default</i> )
F1 <sub>H</sub>	Report full capacity available

**Note**

At power-on, or after a hardware or software reset, the default values of the features are as indicated above.

### 4.3.3 S.M.A.R.T. commands

S.M.A.R.T. provides near-term failure prediction for disk drives. When S.M.A.R.T. is enabled, the drive monitors predetermined drive attributes that are susceptible to degradation over time. If self-monitoring determines that a failure is likely, S.M.A.R.T. makes a status report available to the host. Not all failures are predictable. S.M.A.R.T. predictability is limited to the attributes the drive can monitor. For more information on S.M.A.R.T. commands and implementation, see the *Draft ATA-5 Standard*.

SeaTools diagnostic software activates a built-in drive self-test (DST S.M.A.R.T. command for D4<sub>H</sub>) that eliminates unnecessary drive returns. The diagnostic software ships with all new drives and is also available at: <http://seatools.seagate.com>.

This drive is shipped with S.M.A.R.T. features disabled. Users must have a recent BIOS or software package that supports S.M.A.R.T. to enable this feature. The table below shows the S.M.A.R.T. command codes that the drive uses.

**Table 12 S.M.A.R.T. commands**

Code in features register	S.M.A.R.T. command
D0 <sub>H</sub>	S.M.A.R.T. Read Data
D2 <sub>H</sub>	S.M.A.R.T. Enable/Disable Attribute Autosave
D3 <sub>H</sub>	S.M.A.R.T. Save Attribute Values
D4 <sub>H</sub>	S.M.A.R.T. Execute Off-line Immediate (runs DST)
D5 <sub>H</sub>	S.M.A.R.T. Read Log Sector
D6 <sub>H</sub>	S.M.A.R.T. Write Log Sector
D8 <sub>H</sub>	S.M.A.R.T. Enable Operations
D9 <sub>H</sub>	S.M.A.R.T. Disable Operations
DA <sub>H</sub>	S.M.A.R.T. Return Status

<b>Note</b>	If an appropriate code is not written to the Features Register, the command is aborted and 0x04 (abort) is written to the Error register.
-------------	---



**Seagate Technology LLC**

*AMERICAS Seagate Technology LLC 10200 South De Anza Boulevard, Cupertino, California 95014, United States, 408-658-1000*

*ASIA/PACIFIC Seagate Singapore International Headquarters Pte. Ltd. 7000 Ang Mo Kio Avenue 5, Singapore 569877, 65-6485-3888*

*EUROPE, MIDDLE EAST AND AFRICA Seagate Technology SAS 16-18 rue du Dôme, 92100 Boulogne-Billancourt, France, 33 1-4186 10 00*

*Publication Number: 100825412, Rev. B  
November 2017*