



SKYHAWK AI

SURVEILLANCE

SATA Product Manual

Standard 512E model

ST16000VE000

ST14000VE0008

ST12000VE0008

ST10000VE0008

100855892, Rev. D
May 2020

Document Revision History

Revision	Date	Pages affected and Description of changes
Rev. A	07/11/2019	Initial release.
Rev. B	11/18/2019	8 & 17: Updated AFR to 0.44% 17: Updated MTBF to 2M hours
Rev. C	01/08/2020	8: Updated temperature & humidity gradient values
Rev. D	05/12/2020	fc, 5, 7-9, 26-27 & 39: Added 10TB model 7 & 9: Sustained data transfer rate OD = 250 MB/s max 7 & 10: Startup current (typical) 12V (peak) = 2.0A 16: Removed dot before Acoustics 18: Replaced Regulatory Compliance and Safety information with URL and instructions bc: Updated address to new US HQ

© 2020 Seagate Technology LLC. All rights reserved.

Publication number: 100855892, Rev. D May 2020

Seagate, Seagate Technology and the Spiral logo are registered trademarks of Seagate Technology LLC in the United States and/or other countries. SkyHawk AI, PowerChoice and SeaTools are either trademarks or registered trademarks of Seagate Technology LLC or one of its affiliated companies in the United States and/or other countries. The FIPS logo is a certification mark of NIST, which does not imply product endorsement by NIST, the U.S., or Canadian governments. All other trademarks or registered trademarks are the property of their respective owners.

No part of this publication may be reproduced in any form without written permission of Seagate Technology LLC.

Call 877-PUB-TEK1 (877-782-8351) to request permission.

When referring to drive capacity, one gigabyte, or GB, equals one billion bytes and one terabyte, or TB, equals one trillion bytes. Your computer's operating system may use a different standard of measurement and report a lower capacity. In addition, some of the listed capacity is used for formatting and other functions, and thus will not be available for data storage. Actual quantities will vary based on various factors, including file size, file format, features and application software. Actual data rates may vary depending on operating environment and other factors. The export or re-export of hardware or software containing encryption may be regulated by the U.S. Department of Commerce, Bureau of Industry and Security (for

Contents

Seagate® Technology Support Services	4
<hr/>	
1.0 Introduction	5
1.1 About the Serial ATA interface	6
<hr/>	
2.0 Drive specifications	7
2.1 Specification summary tables	7
2.2 Formatted capacity	9
2.2.1 LBA mode	9
2.3 Recording and interface technology	9
2.4 Start/stop times	10
2.5 Power specifications	10
2.5.1 Power consumption	10
2.5.2 Typical current profiles	11
2.5.3 Conducted noise	11
2.5.4 Voltage tolerance	11
2.5.5 Extended Power Conditions - PowerChoice™	12
2.6 Environmental limits	14
2.6.1 Temperature	14
2.6.2 Humidity	14
2.6.3 Shock and Vibration	15
2.7 Acoustics	16
2.8 Test for Prominent Discrete Tones (PDTs)	16
2.9 Electromagnetic immunity	16
2.10 Reliability	17
2.10.1 Annualized Failure Rate (AFR) and Mean Time Between Failures (MTBF)	17
2.11 HDD and SSD Regulatory Compliance and Safety	18
2.11.1 Regulatory Models	18
2.12 Corrosive environment	18
2.13 Reference documents	18
2.14 Product warranty	19

3.0	Configuring and mounting the drive	20
3.1	Handling and static-discharge precautions	20
3.2	Configuring the drive	20
3.3	Serial ATA cables and connectors	20
3.4	Drive mounting	21
3.4.1	Mechanical specifications	21

4.0	Serial ATA (SATA) interface	22
4.1	Hot-Plug compatibility	22
4.2	Serial ATA device plug connector pin definitions	22
4.3	Supported ATA commands	23
4.3.1	Identify Device command	26
4.3.2	Identify Device Data log	30
4.3.3	Device Statistics log	44
4.3.4	Set Features command	46
4.3.5	S.M.A.R.T. commands	47

Seagate® Technology Support Services

For Seagate Product Support, visit: <https://www.seagate.com/support>

For Seagate Compliance, Safety, and Disposal, visit: <https://www.seagate.com/support>

For Firmware Download and Tools Download for Secure Erase, visit: <https://www.seagate.com/support/downloads/>

For information regarding online support and services, visit: <http://www.seagate.com/contacts/>

For information regarding Warranty Support, visit: <http://www.seagate.com/support/warranty-and-replacements/>

For information regarding data recovery services, visit: <http://www.seagate.com/services-software/recover/>

For Seagate OEM and Distribution partner and Seagate reseller portal, visit: <http://www.seagate.com/partners>

1.0 Introduction

This manual describes the functional, mechanical and interface specifications for the following:
Seagate® SkyHawk® AI Serial ATA drive models.

Table 1: Models

Standard 512E models
ST16000VE000
ST14000VE0008
ST12000VE0008
ST10000VE0008

These drives provide the following key features:

- 256 MB data buffer.
- 7200 RPM spindle speed.
- Full-track multiple-sector transfer capability without local processor intervention.
- High instantaneous (burst) data-transfer rates (up to 600MB per second).
- Native Command Queuing with command ordering to increase performance in demanding applications.
- PowerChoice™ for selectable power savings
- Perpendicular recording technology provides the drives with increased areal density.
- SeaTools™ diagnostic software performs a drive self-test that eliminates unnecessary drive returns.
- State-of-the-art cache and on-the-fly error-correction algorithms.
- Support for S.M.A.R.T. drive monitoring and reporting.
- Supports latching SATA cables and connectors.
- Top Cover Attached motor for excellent vibration tolerance
- Worldwide Name (WWN) capability uniquely identifies the drive.

NOTE Seagate recommends validating the configuration with the selected HBA/RAID controller manufacturer to ensure use of full capacity is supported.

1.1 About the Serial ATA interface

The Serial ATA interface provides several advantages over the traditional (parallel) ATA interface. The primary advantages include:

- Easy installation and configuration with true plug-and-play connectivity. It is not necessary to set any jumpers or other configuration options.
- Thinner and more flexible cabling for improved enclosure airflow and ease of installation.
- Scalability to higher performance levels.

In addition, Serial ATA makes the transition from parallel ATA easy by providing legacy software support. Serial ATA was designed to allow users to install a Serial ATA host adapter and Serial ATA disk drive in the current system and expect all of the existing applications to work as normal.

The Serial ATA interface connects each disk drive in a point-to-point configuration with the Serial ATA host adapter. There is no master/slave relationship with Serial ATA devices like there is with parallel ATA. If two drives are attached on one Serial ATA host adapter, the host operating system views the two devices as if they were both “masters” on two separate ports. This essentially means both drives behave as if they are Device 0 (master) devices.

NOTE The host adapter may, optionally, emulate a master/slave environment to host software where two devices on separate Serial ATA ports are represented to host software as a Device 0 (master) and Device 1 (slave) accessed at the same set of host bus addresses. A host adapter that emulates a master/slave environment manages two sets of shadow registers. This is not a typical Serial ATA environment.

The Serial ATA host adapter and drive share the function of emulating parallel ATA device behavior to provide backward compatibility with existing host systems and software. The Command and Control Block registers, PIO and DMA data transfers, resets, and interrupts are all emulated.

The Serial ATA host adapter contains a set of registers that shadow the contents of the traditional device registers, referred to as the Shadow Register Block. All Serial ATA devices behave like Device 0 devices. For additional information about how Serial ATA emulates parallel ATA, refer to the “Serial ATA: High Speed Serialized AT Attachment” specification. The specification can be downloaded from www.serialata.org.

2.0 Drive specifications

Unless otherwise noted, all specifications are measured under ambient conditions, at 25°C, and nominal power. For convenience, the phrases *the drive* and *this drive* are used throughout this manual to indicate the SkyHawk AI Serial ATA drive models.

2.1 Specification summary tables

The specifications listed in the following tables are for quick reference. For details on specification measurement or definition, see the appropriate section of this manual.

Table 2 Drive specifications summary

Drive specification	ST16000VE000	ST14000VE0008	ST12000VE0008	ST10000VE0008
Formatted (512 bytes/sector)*	16TB	14TB	12TB	10TB
Guaranteed sectors	(see Section 2.2)			
Heads	18		16	
Discs	9			
Bytes per logical sector	512			
Bytes per physical sector	4096			
Recording density, KBPI (Kb/in max)	2426			
Track density, KTPI (ktracks/in avg.)	436			
Areal density, (Gb/in ² avg)	1028			
Spindle speed (RPM)	7200			
Internal data transfer rate (Mb/s max)	2833			
Sustained data transfer rate OD (MB/s max)	250			
I/O data-transfer rate (MB/s max)	600			
ATA data-transfer modes supported	PIO modes 0–4 Multiword DMA modes 0–2 Ultra DMA modes 0–6			
Cache buffer	256MB (262,144KB)			
Weight: (maximum)	670g (1.477 lb)			
Average latency	4.16ms			
Power-on to ready (sec) (typ/max)	23/30			
Standby to ready (sec) (typ/max)	23/30			
Startup current (typical) 12V (peak)	2.0A			
Voltage tolerance (including noise)	5V ± 5% 12V ± 10%			
Operating drive temperature*	5° to 70°C (Drive Reported Temperature)			
Non-Operating temperature	–40° to 70°C (Ambient Temperature, see sections 2.6.1 and 2.13)			

Drive specification	ST16000VE000	ST14000VE0008	ST12000VE0008	ST10000VE0008
Temperature gradient (°C per hour max)	20°C (operating) 20°C (nonoperating)			
Relative humidity*	5% to 95% (operating) 5% to 95% (nonoperating)			
Relative humidity gradient	20% per hour max			
Altitude, operating	-304.8 m to 3,048 m (-1000 ft to 10,000+ ft)			
Altitude, nonoperating (below mean sea level, max)	-304.8 m to 12,192 m (-1000 ft to 40,000+ ft)			
Operational Shock (max at 2 ms - typical)	50 Gs			
Non-Operational Shock (max at 2 ms - typical)	200 Gs			
Linear Random Operating Vibration	5-500 Hz: 0.70 Grms			
Random Rotary Operating Vibration	20-1500Hz: 12.5 rads/s ²			
Linear Random Non-Operating Vibration	2-500 Hz: 2.27 Grms			
Drive acoustics, sound power (bels)				
Idle	1.8 (typical) 2.0 (max) During periods of drive idle, some offline activity may occur according to the SMART specification, which may increase acoustic and power to operational levels.			
Performance seek	2.6 (typical) 2.8 (max)			
Nonrecoverable read errors	1 sector per 10 ¹⁵ bits read			
Annualized Failure Rate (AFR)*	0.44% based on 8760 POH			
Maximum Rated Workload*	Maximum rate of <550TB/year Workloads exceeding the annualized rate may degrade the drive MTBF and impact product reliability. The Annualized Workload Rate is in units of TB per year, or TB per 8760 power on hours. Workload Rate = TB transferred * (8760 / recorded power on hours).			
Warranty	To determine the warranty for a specific drive, use a web browser to access the following web page: http://www.seagate.com/support/warranty-and-replacements/ . From this page, click on the "Is my Drive under Warranty" link. The following are required to be provided: the drive serial number, model number (or part number) and country of purchase. The system will display the warranty information for the drive.			
Load-unload cycles	300,000			
Supports Hotplug operation per Serial ATA Revision 3.3 specification	Yes			

*See [Section 2.10, "Reliability"](#) for rated MTBF device operating condition requirements.

2.2 Formatted capacity

ST models	Formatted capacity*	Guaranteed sectors	Bytes per logical sector
ST16000VE000	16TB	31,251,759,104	512E
ST14000VE0008	14TB	27,344,764,928	
ST12000VE0008	12TB	23,437,770,752	
ST10000VE0008	10TB	19,532,873,728	

*One GB equals one billion bytes when referring to hard drive capacity. Accessible capacity may vary depending on operating environment and formatting.

NOTE

LBA Counts for drive capacities greater than 8TB are calculated based upon the SFF-8447 standard publication. <ftp://ftp.seagate.com/sff/SFF-8447.PDF>

2.2.1 LBA mode

When addressing these drives in LBA mode, all blocks (sectors) are consecutively numbered from 0 to $n-1$, where n is the number of guaranteed sectors as defined above.

See [Section 4.3.1, "Identify Device command"](#) (words 60-61 and 100-103) for additional information about 48-bit addressing support of drives with capacities over 137GB.

2.3 Recording and interface technology

Interface	Serial ATA (SATA)
Recording method	Perpendicular
Recording density, KBPI (Kb/in max)	2426
Track density, KTPI (ktracks/in avg)	436
Areal density (Gb/in ² avg)	1028
Spindle speed (RPM) (\pm 0.2%)	7200
Internal data transfer rate (Mb/s max)	2833
Sustained data transfer rate (MB/s max)	250
I/O data-transfer rate (MB/s max)	600 (Ultra DMA mode 5)

2.4 Start/stop times

Power-on to Ready (sec) (typ/max)	23/30
Standby to Ready (sec) (typ/max)	23/30
Ready to spindle stop (sec) (max)	20

2.5 Power specifications

The drive receives DC power (+5V or +12V) through a native SATA power connector. [See Figure 2 on page 20](#).

2.5.1 Power consumption

Power requirements for the drives are listed in [Table 3](#). Typical power measurements are based on an average of drives tested, under nominal conditions, using 5.0V and 12.0V input voltage at 25°C ambient temperature.

Table 3 DC Power Requirements

Power Dissipation	Avg (25°C) (Watts)	Avg 5V typical (Amps)	Avg 12V typical (Amps)
Spinup (max)			2.0A
Idle ¹	5.07	0.207	0.316
Operating*	6.71	0.737	0.252
Standby	1.05	0.172	0.016
Sleep	1.05	0.172	0.016

1. During periods of drive idle, some offline activity may occur according to the S.M.A.R.T. specification, which may increase acoustic and power to operational levels.

* Based on IDEMA 3 Stream workload

2.5.2 Typical current profiles

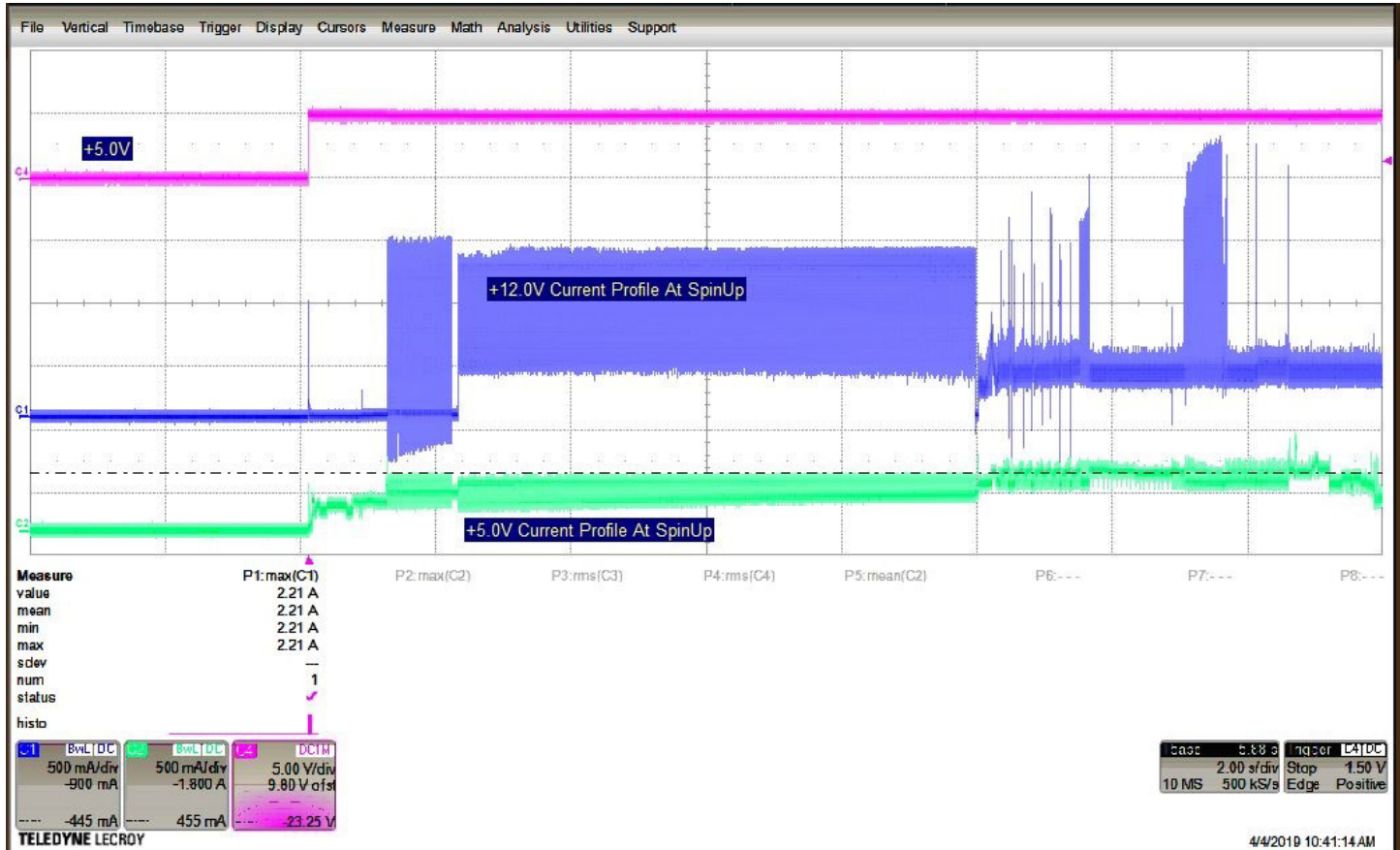

Figure 1. Typical 5V and 12V startup and operation current profiles

2.5.3 Conducted noise

Noise is specified as a periodic and random distribution of frequencies covering a band from DC to 10 MHz. Maximum allowed noise values given below are peak-to-peak measurements and apply at the drive power connector.

- +5v = 250 mV pp from 100 Hz to 20 MHz.
- +12v = 800 mV pp from 100 Hz to 8 KHz.
450 mV pp from 8 KHz to 20 KHz.
250 mV pp from 20 KHz to 5 MHz.

2.5.4 Voltage tolerance

Voltage tolerance (including noise):

5V \pm 5% 12V \pm 10%

2.5.5 Extended Power Conditions - PowerChoice™

Utilizing the load/unload architecture a programmable power management interface is provided to tailor systems for reduced power consumption and performance requirements.

The table below lists the supported power conditions available in PowerChoice. Power conditions are ordered from highest power consumption (and shortest recovery time) to lowest power consumption (and longest recovery time) as follows: Idle_a power >= Idle_b power >= Idle_c power >= Standby_z power. The further users go down in the table, the more power savings is actualized. For example, Idle_b results in greater power savings than the Idle_a power condition. Standby results in the greatest power savings.

Power Condition Name	Power Condition ID	Description
Idle_a	81 _H	Reduced electronics
Idle_b	82 _H	Heads unloaded. Disks spinning at full RPM
Idle_c	83 _H	Heads unloaded. Disks spinning at reduced RPM
Standby_z	00 _H	Heads unloaded. Motor stopped (disks not spinning)

Each power condition has a set of current, saved and default settings. Default settings are not modifiable. Default and saved settings persist across power-on resets. The current settings do not persist across power-on resets. At the time of manufacture, the default, saved and current settings are in the Power Conditions log match.

PowerChoice is invoked using one of two methods

- Automatic power transitions which are triggered by expiration of individual power condition timers. These timer values may be customized and enabled using the Extended Power Conditions (EPC) feature set using the standardized Set Features command interface.
- Immediate host commanded power transitions may be initiated using an EPC Set Features “Go to Power Condition” subcommand to enter any supported power condition. Legacy power commands Standby Immediate and Idle Immediate also provide a method to directly transition the drive into supported power conditions.

PowerChoice exits power saving states under the following conditions

- Any command which requires the drive to enter the PM0: Active state (media access)
- Power on reset

PowerChoice provides the following reporting methods for tracking purposes

Check Power Mode Command

- Reports the current power state of the drive

Identify Device Command

- EPC Feature set supported flag
- EPC Feature enabled flag is set if at least one Idle power condition timer is enabled

Power Condition Log reports the following for each power condition

- Nominal recovery time from the power condition to active
- If the power condition is Supported, Changeable, and Savable
- Default enabled state, and timer value
- Saved enabled state, and timer value
- Current enabled state, and timer value

S.M.A.R.T. Read Data Reports

- Attribute 192 - Emergency Retract Count
- Attribute 193 - Load/Unload Cycle Count

PowerChoice Manufacture Default Power Condition Timer Values

Default power condition timer values have been established to assure product reliability and data integrity. A minimum timer value threshold of two minutes ensures the appropriate amount of background drive maintenance activities occur. Attempting to set a timer values less than the specified minimum timer value threshold will result in an aborted EPC "Set Power Condition Timer" subcommand.

Power Condition Name	Manufacturer Default Timer Values
Idle_a	100 ms
Idle_b	2 min
Idle_c	4 min
Standby_z	15 min

Setting power condition timer values less than the manufacturer specified defaults or issuing the EPC "Go to Power Condition" subcommand at a rate exceeding the default timers may limit this products reliability and data integrity.

PowerChoice Supported Extended Power Condition Feature Subcommands

EPC Subcommand	Description
00 _H	Restore Power Condition Settings
01 _H	Go to Power Condition
02 _H	Set Power Condition Timer
03 _H	Set Power Condition State
04 _H	Enable EPC Feature Set
05 _H	Disable EPC Feature Set

PowerChoice Supported Extended Power Condition Identifiers

Power Condition Identifiers	Power Condition Name
00 _H	Standby_z
01 - 80 _H	Reserved
81 _H	Idle_a
82 _H	Idle_b
83 _H	Idle_c
84 - FE _H	Reserved
FF _H	All EPC Power Conditions

2.6 Environmental limits

Temperature and humidity values experienced by the drive must be such that condensation does not occur on any drive part. Altitude and atmospheric pressure specifications are referenced to a standard day at 58.7°F (14.8°C).

NOTE To maintain optimal performance drives should be run at nominal drive temperatures and humidity.

See [Section 2.10, "Reliability"](#) for rated MTBF device operating condition requirements.

2.6.1 Temperature

a. Operating

41°F to 158°F (5°C to 70°C) temperature range with a maximum temperature gradient of 36°F (20°C) per hour as reported by the drive.

The maximum allowable drive reported temperature is 158°F (70°C).

Air flow may be required to achieve consistent nominal drive temperature values (see [Section 3.4](#)). To confirm that the required cooling is provided for the electronics and HDA, place the drive in its final mechanical configuration, and perform random write/read operations. After the temperatures stabilize, monitor the current drive temperature using the SMART temperature attribute 194 or Device Statistics log 04h page 5.

b. Non-operating

–40° to 158°F (–40° to 70°C) package ambient with a maximum gradient of 36°F (20°C) per hour. This specification assumes that the drive is packaged in the shipping container designed by Seagate for use with drive.

2.6.2 Humidity

The values below assume that no condensation on the drive occurs. Maximum wet bulb temperature is 84.2°F (29°C).

2.6.2.1 Relative humidity

Operating:	5% to 95% non-condensing relative humidity with a maximum gradient of 20% per hour.
Nonoperating:	5% to 95% non-condensing relative humidity with a maximum gradient of 20% per hour.

2.6.2.2 Effective Altitude (sea level)

Operating:	–304.8 m to 3048 m (–1000 ft. to 10,000+ ft.)
Nonoperating:	–304.8 m to 12,192 m (–1000 ft. to 40,000+ ft.)

2.6.3 Shock and Vibration

Shock and vibration measurements specified in this document are made directly on the drive itself and applied in the X, Y, and Z axis at the drive mounting point locations.

2.6.3.1 Shock

a. Operating

The drive will operate without error while subjected to intermittent shock pulses not exceeding 50 Gs at a maximum duration of 2ms.

b. Non-operating

The drive will operate without non-recoverable errors after being subjected to shock pulses not exceeding 200g at a maximum duration of 2ms.

2.6.3.2 Vibration

a. Linear Random Operating Vibration

The drive will operate without non-recoverable errors while being subjected to the random power spectral density noise specified below.

PSD of 5-500 Hz random noise at 0.70 g rms					
Frequency (Hz)	5	20	200	250	500
G ² /Hz	0.00025	0.00210	0.00210	0.00020	0.00020

b. Random Rotary Operating Vibration

The drive will exhibit greater than 90% throughput for sequential and random write operations while subjected to the shaped random power spectral density noise specified below.

PSD Profile 20-1500 Hz at 12.5 rad/sec ²				
Frequency (Hz)	20	200	800	1500
(rad/sec ²) ² /Hz	5.53E-02	5.53E-02	3.49E-01	6.14E-04

c. Linear Random Non-Operating Vibration

The drive will not incur physical damage or have non-recoverable errors after being subjected to the power spectral density noise specified below.

PSD Profile 2-500 Hz at 2.27 g rms				
Frequency (Hz)	2	4	100	500
G ² /Hz	0.001	0.030	0.030	0.001

2.7 Acoustics

Drive acoustics are measured as overall A-weighted acoustic sound power levels (no pure tones). All measurements are consistent with ISO document 7779. Sound power measurements are taken under essentially free-field conditions over a reflecting plane. For all tests, the drive is oriented with the cover facing upward.

NOTE For seek mode tests, the drive is placed in seek mode only. The number of seeks per second is defined by the following equation:
 (Number of seeks per second = $0.4 / (\text{average latency} + \text{average access time})$)

Table 4 Fluid Dynamic Bearing (FDB) motor acoustics

	Idle*	Performance seek
All models	1.8 bels (typ) 2.0 bels (max)	2.6 bels (typ) 2.8 bels (max)

*During periods of drive idle, some offline activity may occur according to the S.M.A.R.T. specification, which may increase acoustic and power to operational levels.

2.8 Test for Prominent Discrete Tones (PDTs)

Seagate follows the ECMA-74 standards for measurement and identification of PDTs. An exception to this process is the use of the absolute threshold of hearing. Seagate uses this threshold curve (originated in ISO 389-7) to discern tone audibility and to compensate for the inaudible components of sound prior to computation of tone ratios according to Annex D of the ECMA-74 standards.

2.9 Electromagnetic immunity

When properly installed in a representative host system, the drive operates without errors or degradation in performance when subjected to the radio frequency (RF) environments defined in the following table:

Table 5 Radio frequency environments

Test	Description	Performance level	Reference standard
Electrostatic discharge	Contact, HCP, VCP: ± 4 kV; Air: ± 8 kV	B	EN 61000-4-2: 95
Radiated RF immunity	80 to 1000 MHz, 3 V/m, 80% AM with 1 kHz sine 900 MHz, 3 V/m, 50% pulse modulation @ 200 Hz	A	EN 61000-4-3: 96 ENV 50204: 95
Electrical fast transient	± 1 kV on AC mains, ± 0.5 kV on external I/O	B	EN 61000-4-4: 95
Surge immunity	± 1 kV differential, ± 2 kV common, AC mains	B	EN 61000-4-5: 95
Conducted RF immunity	150 kHz to 80 MHz, 3 Vrms, 80% AM with 1 kHz sine	A	EN 61000-4-6: 97
Voltage dips, interrupts	0% open, 5 seconds 0% short, 5 seconds 40%, 0.10 seconds 70%, 0.01 seconds	C C C B	EN 61000-4-11: 94

2.10 Reliability

2.10.1 Annualized Failure Rate (AFR) and Mean Time Between Failures (MTBF)

The production disk drive shall achieve an annualized failure-rate of 0.44% (MTBF of 2,000,000 hours) over a 5 year service life when used in Surveillance Storage field conditions as limited by the following:

- 8760 power-on hours per year.
- HDA temperature as reported by the drive $\leq 30^{\circ}\text{C}$
- Ambient wet bulb temp $\leq 26^{\circ}\text{C}$
- Typical workload
- The AFR (MTBF) is a population statistic not relevant to individual units
- ANSI/ISA S71.04-2013 G2 classification levels and dust contamination to ISO 14644-1 Class 8 standards (as measured at the device)

The MTBF specification for the drive assumes the operating environment is designed to maintain nominal drive temperature and humidity. Occasional excursions in operating conditions between the rated MTBF conditions and the maximum drive operating conditions may occur without significant impact to the rated MTBF. However continual or sustained operation beyond the rated MTBF conditions will degrade the drive MTBF and reduce product reliability.

Nonrecoverable read errors	1 per 10^{15} bits read, max
Load unload cycles	300,000 cycles
Maximum Rated Workload	Maximum rate of <550TB/year Workloads exceeding the annualized rate may degrade the drive MTBF and impact product reliability. The Annualized Workload Rate is in units of TB per year, or TB per 8760 power on hours. Workload Rate = TB transferred * (8760 / recorded power on hours).
Warranty	To determine the warranty for a specific drive, use a web browser to access the following web page: http://www.seagate.com/support/warranty-and-replacements/ . From this page, click on the "Is my Drive under Warranty" link. The following are required to be provided: the drive serial number, model number (or part number) and country of purchase. The system will display the warranty information for the drive.
Preventive maintenance	None required.

2.10 HDD and SSD Regulatory Compliance and Safety

For the latest regulatory and compliance information see: <https://www.seagate.com/support/> scroll to bottom of page and click the Seagate HDD and SSD Regulatory Compliance and Safety link.

2.10.1 Regulatory Models

The following regulatory model number represent all features and configurations within the series:

Regulatory Model Numbers: STL006

2.11 Corrosive environment

Seagate electronic drive components pass accelerated corrosion testing equivalent to 10 years exposure to light industrial environments containing sulfurous gases, chlorine and nitric oxide, classes G and H per ASTM B845. However, this accelerated testing cannot duplicate every potential application environment.

Users should use caution exposing any electronic components to uncontrolled chemical pollutants and corrosive chemicals as electronic drive component reliability can be affected by the installation environment. The silver, copper, nickel and gold films used in hard disk drives are especially sensitive to the presence of sulfide, chloride, and nitrate contaminants. Sulfur is found to be the most damaging. Materials used in cabinet fabrication, such as vulcanized rubber, that can outgas corrosive compounds should be minimized or eliminated. The useful life of any electronic equipment may be extended by replacing materials near circuitry with sulfide-free alternatives.

Seagate recommends that data centers be kept clean by monitoring and controlling the dust and gaseous contamination. Gaseous contamination should be within ANSI/ISA 571.04-2013 G2 classification levels (as measured on copper and silver coupons), and dust contamination to ISO 14644-1 Class 8 standards, and MTBF rated conditions as defined in the Annualized Failure Rate (AFR) and Mean Time Between Failure (MTBF) section.

2.12 Reference documents

Supported Standards

Serial ATA Revision 3.3 specification

ANSI Documents

INCITS 522-2014ATA/ATAPI Command Set - 3 (ACS-3)

Specification for Acoustic Test Requirement and Procedures

Seagate part number: 30553-001

In case of conflict between this document and any referenced document, this document takes precedence.

2.13 Product warranty

Beginning on the date of shipment to the customer and continuing for the period specified in the purchase contract, Seagate warrants that each product (including components and subassemblies) that fails to function properly under normal use due to defect in materials or workmanship or due to nonconformance to the applicable specifications will be repaired or replaced, at Seagate's option and at no charge to the customer, if returned by customer at customer's expense to Seagate's designated facility in accordance with Seagate's warranty procedure. Seagate will pay for transporting the repair or replacement item to the customer. For more detailed warranty information, refer to the standard terms and conditions of purchase for Seagate products on the purchase documentation.

The remaining warranty for a particular drive can be determined by calling Seagate Customer Service at 1-800-468-3472. Users can also determine remaining warranty using the Seagate web site (www.seagate.com). The drive serial number is required to determine remaining warranty information.

Shipping

When transporting or shipping a drive, use only a Seagate-approved container. Keep the original box. Seagate approved containers are easily identified by the Seagate Approved Package label. Shipping a drive in a non-approved container voids the drive warranty.

Seagate repair centers may refuse receipt of components improperly packaged or obviously damaged in transit. Contact the authorized Seagate distributor to purchase additional boxes. Seagate recommends shipping by an air-ride carrier experienced in handling computer equipment.

Storage

Maximum storage periods are 180 days within original unopened Seagate shipping package or 60 days unpackaged within the defined non-operating limits (refer to environmental section in this manual). Storage can be extended to 1 year packaged or unpackaged under optimal environmental conditions (25°C, <40% relative humidity non-condensing, and non-corrosive environment). During any storage period the drive non-operational temperature, humidity, wet bulb, atmospheric conditions, shock, vibration, magnetic and electrical field specifications should be followed.

Product repair and return information

Seagate customer service centers are the only facilities authorized to service Seagate drives. Seagate does not sanction any third-party repair facilities. Any unauthorized repair or tampering with the factory seal voids the warranty.

3.0 Configuring and mounting the drive

This section contains the specifications and instructions for configuring and mounting the drive.

3.1 Handling and static-discharge precautions

After unpacking, and before installation, the drive may be exposed to potential handling and electrostatic discharge (ESD) hazards. Observe the following standard handling and static-discharge precautions:

Caution

- Before handling the drive, put on a grounded wrist strap, or ground oneself frequently by touching the metal chassis of a computer that is plugged into a grounded outlet. Wear a grounded wrist strap throughout the entire installation procedure.
- Handle the drive by its edges or frame *only*.
- The drive is extremely fragile—handle it with care. Do not press down on the drive top cover.
- Always rest the drive on a padded, antistatic surface until mounting it in the computer.
- Do not touch the connector pins or the printed circuit board.
- Do not remove the factory-installed labels from the drive or cover them with additional labels. Removal voids the warranty. Some factory-installed labels contain information needed to service the drive. Other labels are used to seal out dirt and contamination.

3.2 Configuring the drive

Each drive on the Serial ATA interface connects point-to-point with the Serial ATA host adapter. There is no master/slave relationship because each drive is considered a master in a point-to-point relationship. If two drives are attached on one Serial ATA host adapter, the host operating system views the two devices as if they were both “masters” on two separate ports. Both drives behave as if they are Device 0 (master) devices.

3.3 Serial ATA cables and connectors

The Serial ATA interface cable consists of four conductors in two differential pairs, plus three ground connections. The cable size may be 30 to 26 AWG with a maximum length of one meter (39.37 in).

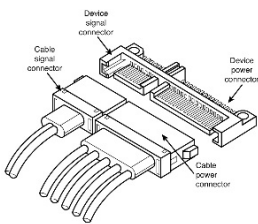

See [Table 6](#) for connector pin definitions. Either end of the SATA signal cable can be attached to the drive or host.

For direct backplane connection, the drive connectors are inserted directly into the host receptacle. The drive and the host receptacle incorporate features that enable the direct connection to be hot pluggable and blind mateable.

For installations which require cables, users can connect the drive as illustrated in [Figure 2](#).

Figure 2. Attaching SATA cabling

NOTE Each cable is keyed to ensure correct orientation.
SkyHawk AI Serial ATA drives support latching SATA connectors.

3.4 Drive mounting

Users can mount the drive in any orientation using four screws in the side-mounting holes or four screws in the bottom-mounting holes. See **Figure 3** for drive mounting dimensions. Follow these important mounting precautions when mounting the drive:

- Allow a minimum clearance of 0.030 in (0.76mm) around the entire perimeter of the drive for cooling.
- Use only 6-32 UNC mounting screws.
- The screws should be inserted no more than 0.140 in (3.56mm) into the bottom or side mounting holes.
- Do not overtighten the mounting screws (maximum torque: 6 in-lb).

3.4.1 Mechanical specifications

Refer to **Figure 3** for detailed mounting configuration dimensions. See **Section 3.4**, "Drive mounting."

Weight:	1.477 lb	670 g
---------	----------	-------

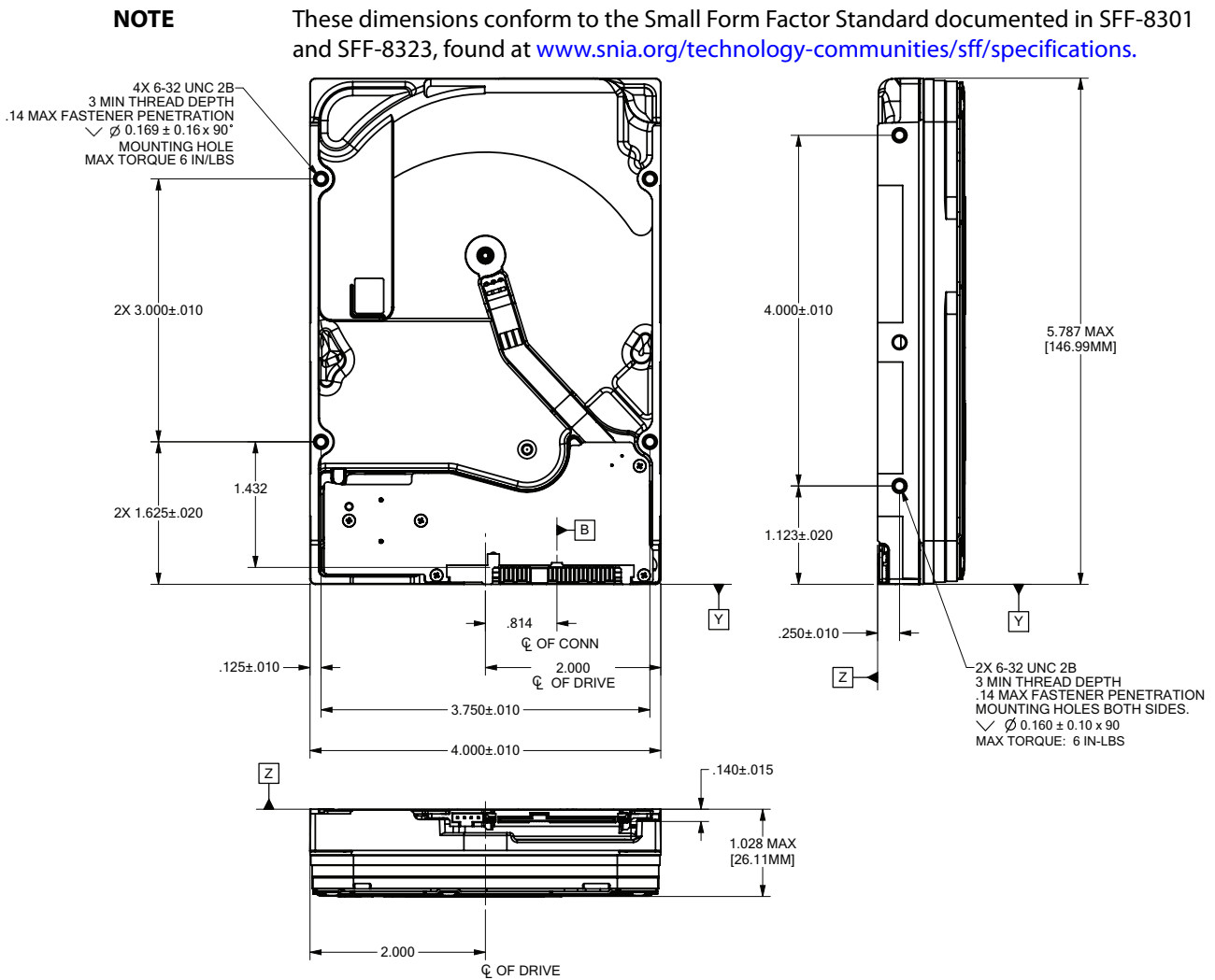

Figure 3. Mounting configuration dimensions

NOTE The image is for mechanical dimension reference only and may not represent the actual drive.

4.0 Serial ATA (SATA) interface

These drives use the industry-standard Serial ATA interface that supports FIS data transfers. It supports ATA programmed input/output (PIO) modes 0–4; multiword DMA modes 0–2, and Ultra DMA modes 0–6.

For detailed information about the Serial ATA interface, refer to the “Serial ATA: High Speed Serialized AT Attachment” specification.

4.1 Hot-Plug compatibility

SkyHawk AI Serial ATA drives incorporate connectors which enable users to hot plug these drives in accordance with the Serial ATA Revision 3.3 specification. This specification can be downloaded from www.serialata.org.

Caution

The drive motor must come to a complete stop (**Ready to spindle stop time indicated in Section 2.4**) prior to changing the plane of operation. This time is required to insure data integrity.

4.2 Serial ATA device plug connector pin definitions

Table 6 summarizes the signals on the Serial ATA interface and power connectors.

Table 6 Serial ATA connector pin definitions

Segment	Pin	Function	Definition
Signal	S1	Ground	2nd mate
	S2	A+	Differential signal pair A from Phy
	S3	A-	
	S4	Ground	2nd mate
	S5	B-	Differential signal pair B from Phy
	S6	B+	
	S7	Ground	2nd mate
Key and spacing separate signal and power segments			
Power	P1	V33	3.3V power
	P2	V33	3.3V power
	P3	V33	3.3V power, pre-charge, 2nd mate
	P4	Ground	1st mate
	P5	Ground	2nd mate
	P6	Ground	2nd mate
	P7	V5	5V power, pre-charge, 2nd mate
	P8	V5	5V power
	P9	V5	5V power
	P10	Ground	2nd mate
	P11	Ground or LED signal	If grounded, drive does not use deferred spin
	P12	Ground	1st mate.
	P13	V12	12V power, pre-charge, 2nd mate
	P14	V12	12V power
	P15	V12	12V power

Notes:

1. All pins are in a single row, with a 1.27mm (0.050") pitch.
2. The comments on the mating sequence apply to the case of backplane blindmate connector only. In this case, the mating sequences are:
 - the ground pins P4 and P12.
 - the pre-charge power pins and the other ground pins.
 - the signal pins and the rest of the power pins.
3. There are three power pins for each voltage. One pin from each voltage is used for pre-charge when installed in a blind-mate backplane configuration.
4. All used voltage pins (Vx) must be terminated.

4.3 Supported ATA commands

The following table lists Serial ATA standard commands that the drive supports. For a detailed description of the ATA commands, refer to the Serial ATA: High Speed Serialized AT Attachment specification. See [“S.M.A.R.T. commands” on page 47](#) for details and subcommands used in the S.M.A.R.T. implementation.

Table 7 Supported ATA commands

Command name	Command code (in hex)
Accessible Max Address Configuration	
Get Native Max Address Ext	78 _H / 0000 _H
Set Accessible Max Address Ext	78 _H / 0001 _H
Freeze Accessible Max Address Ext	78 _H / 0002 _H
Check Power Mode	E5 _H
Configure Stream	51 _H
Download Microcode	92 _H
Execute Device Diagnostics	90 _H
Flush Cache	E7 _H
Flush Cache Extended	EA _H
Get Physical Element Status	12 _H
Identify Device	EC _H
Idle	E3 _H
Idle Immediate	E1 _H
Read Buffer	E4 _H
Read DMA	C8 _H
Read DMA Extended	25 _H
Read FPDMA Queued	60 _H
Read Log DMA Ext	47 _H
Read Log Ext	2F _H
Read Multiple	C4 _H

Command name	Command code (in hex)
Read Multiple Extended	29 _H
Read Sectors	20 _H
Read Sectors Extended	24 _H
Read Stream DMA Extended	2A _H
Read Verify Sectors	40 _H
Read Verify Sectors Extended	42 _H
Receive FPDMA Queued	65 _H
Request Sense Data Ext	0B _H
Remove Element And Truncate	7C _H
Sanitize Device - Overwrite Ext	B4 _H / 0014 _H
Sanitize Device - Freeze Lock Ext	B4 _H / 0020 _H
Sanitize Device - Status Ext	B4 _H / 0000 _H
Security Disable Password	F6 _H
Security Erase Prepare	F3 _H
Security Erase Unit	F4 _H
Security Freeze	F5 _H
Security Set Password	F1 _H
Security Unlock	F2 _H
Seek	70 _H
Send FPDMA Queued	64 _H
Set Date & Time Ext	77 _H
Set Features	EF _H
Set Multiple Mode	C6 _H
Sleep	E6 _H
S.M.A.R.T. Disable Operations	B0 _H / D9 _H
S.M.A.R.T. Enable/Disable Autosave	B0 _H / D2 _H
S.M.A.R.T. Enable Operations	B0 _H / D8 _H
S.M.A.R.T. Execute Offline	B0 _H / D4 _H
S.M.A.R.T. Read Attribute Thresholds	B0 _H / D1 _H
S.M.A.R.T. Read Data	B0 _H / D0 _H
S.M.A.R.T. Read Log Sector	B0 _H / D5 _H
S.M.A.R.T. Return Status	B0 _H / DA _H
S.M.A.R.T. Save Attribute Values	B0 _H / D3 _H
S.M.A.R.T. Write Log Sector	B0 _H / D6 _H
Standby	E2 _H
Standby Immediate	E0 _H

Command name	Command code (in hex)
Trusted Send	5E _H (SED drives only)
Trusted Send DMA	5F _H (SED drives only)
Trusted Receive	5C _H (SED drives only)
Trusted Receive DMA	5D _H (SED drives only)
Write Buffer	E8 _H
Write DMA	CA _H
Write DMA Extended	35 _H
Write DMA FUA Extended	3D _H
Write FPDMA Queued	61 _H
Write Log DMA Ext	57 _H
Write Log Extended	3F _H
Write Multiple	C5 _H
Write Multiple Extended	39 _H
Write Multiple FUA Extended	CE _H
Write Sectors	30 _H
Write Sectors Extended	34 _H
Write Stream DMA Extended	3A _H
Write Uncorrectable Extended	45 _H

4.3.1 Identify Device command

The Identify Device command (command code EC_H) transfers information about the drive to the host following power up. The data is organized as a single 512-byte block of data, whose contents are shown in [Table 7](#) on [page 23](#). All reserved bits or words should be set to zero. Parameters listed with an “x” are drive-specific or vary with the state of the drive. [see Section 2.0 on page 7](#) for default parameter settings.

The following commands contain drive-specific features that may not be included in the Serial ATA specification.

Table 8 Identify Device command

Word	Description	Value
0	Configuration information: • Bit 15: 0 = ATA; 1 = ATAPI • Bit 7: removable media • Bit 6: removable controller • Bit 0: reserved	0C5A _H
1	Obsolete	16,383
2	ATA-reserved	C837 _H
3	Obsolete	16
4	Retired	0000 _H
5	Retired	0000 _H
6	Obsolete	003F _H
7–9	Retired	0000 _H
10–19	Serial number: (20 ASCII characters, 0000 _H = none)	ASCII
20–21	Retired	0000 _H
22	Obsolete	0000 _H
23–26	Firmware revision (8 ASCII character string, padded with blanks to end of string)	x.xx
27–46	Drive model number: (40 ASCII characters, padded with blanks to end of string)	ST16000VE000 ST14000VE0008 ST12000VE0008 ST10000VE0008
47	(Bits 7–0) Maximum sectors per interrupt on Read multiple and Write multiple (16)	8010 _H (512e) / 8002 _H (4KN)
48	Trusted computing feature set supported bit 0 (SED only)	4000 _H
49	Standard Standby timer, IORDY supported and may be disabled	2F00 _H
50	Capabilities	4000 _H
51–52	Obsolete	xxxx _H
53–56	Words 54–58, 64–70 and 88 are valid	xxxx _H
57–58	Obsolete	xxxx _H
59	(Bit 15: 0) Block Erase Ext Not Supported - N (Bit 14: 1) Overwrite Ext Supported - Y (Bit 13: X) Crypto Scramble Ext Supported (SED Only) - N (Bit 12: 1) Sanitize feature set supported - Y (Bit 11: 1) Commands allowed during sanitize op as specified in ACS-3 - Y (Bit 10: 1) Sanitize Antifreeze Lock Ext command supported - Y	5D10 _H (512E) / 5D02 _H (4KN)

Table 8 Identify Device command

Word	Description	Value
60–61	Total number of user-addressable LBA sectors available (see Section 2.2 for related information) *Note: The maximum value allowed in this field is: 0FFFFFFFh (268,435,455 sectors, 137GB). Drives with capacities over 137GB will have 0FFFFFFFh in this field and the actual number of user-addressable LBAs specified in words 100-103. This is required for drives that support the 48-bit addressing feature.	0FFFFFFFh*
62	Obsolete	0000 _H
63	Multiword DMA active and modes supported (see note following this table)	xx07 _H
64	Advanced PIO modes supported (modes 3 and 4 supported)	0003 _H
65	Minimum multiword DMA transfer cycle time per word (120 ns)	0078 _H
66	Recommended multiword DMA transfer cycle time per word (120 ns)	0078 _H
67	Minimum PIO cycle time without IORDY flow control (240 ns)	0078 _H
68	Minimum PIO cycle time with IORDY flow control (120 ns)	0078 _H
69	Additional supported	0008 _H
70–74	ATA-reserved	0000 _H
75	Queue depth	001F _H
76	Serial ATA capabilities	8D0E _H
77	(Bit 6:1) Send/Receive FPDMA Queued Commands Supported	xx4x _H
78	Serial ATA features supported	80CC _H
79	Serial ATA features enabled	xxxx _H
80	Major version number	0FE0 _H
81	Minor version number	005E _H
82	Command sets supported	306B _H
83	Command sets supported	7561 _H
84	Command sets support extension (see note following this table)	6173 _H
85	Command sets enabled	3069 _H
86	Command sets enabled	B441 _H
87	Command sets enable extension	6173 _H
88	Ultra DMA support and current mode (see note following this table)	xx7F _H
89	Security erase time	xxxx _H
90	Enhanced security erase time	xxxx _H
92	Master password revision code	FFFE _H
93	Hardware reset value	xxxx _H
95–99	ATA-reserved	0000 _H
100–103	Total number of user-addressable LBA sectors available (see Section 2.2 for related information). These words are required for drives that support the 48-bit addressing feature. Maximum value: 0000FFFFFFFFFh.	ST16000VE000 = 31,251,759,104 ST14000VE0008 = 27,344,764,928 ST12000VE0008 = 23,437,770,752 ST10000VE0008 = 19,532,873,728

Table 8 Identify Device command

Word	Description	Value
104–105	ATA-reserved	0000 _H
106	Physical/Logical sector size	6003 _H (512E) / 5000 _H (4KN)
107	ATA-reserved	0000 _H
108–111	The mandatory value of the world wide name (WWN) for the drive. NOTE: This field is valid if word 84, bit 8 is set to 1 indicating 64-bit WWN support.	Each drive will have a unique value.
112–118	ATA-reserved	0000 _H
119	Commands and feature sets supported	43DE _H
120	Commands and feature sets supported or enabled	409C _H
121–127	ATA-reserved	0000 _H
128	Security status	0029 _H
129–159	Seagate-reserved	xxxx _H
160–167	ATA-reserved	0000 _H
168	Device Nominal Form Factor	3.5"
169–205	ATA-reserved	0000 _H
206	SCT Command Transport command set. If bit 0 is set to one, then the device supports SCT Command Transport. Bits 7:2 indicate individual SCT feature support.	xxBD _H
207–216	ATA-reserved	0000 _H
217	Nominal media rotation rate	7200
218–221	ATA-reserved	0000 _H
222	Transport Major Version	11FF _H
223	Transport Minor Version	0000 _H
224–229	ATA-reserved	0000 _H
230–233	Extended Number of User Accessible Sectors	65DE0000 - (512E) CBBC0000 - (4KN)
234–254	ATA-reserved	0000 _H
255	Integrity word	xxA5 _H

NOTE

See the bit descriptions below for words 63, 84, and 88 of the Identify Drive data.

Description (if bit is set to 1)		
Bit	Word 63	
0	Multiword DMA mode 0 is supported.	
1	Multiword DMA mode 1 is supported.	
2	Multiword DMA mode 2 is supported.	
8	Multiword DMA mode 0 is currently active.	
9	Multiword DMA mode 1 is currently active.	
10	Multiword DMA mode 2 is currently active.	
Bit	Word 84	
0	SMART error logging is supported.	
1	SMART self-test is supported.	
2	Media serial number is not supported.	
3	Media Card Pass Through Command feature set is not supported.	
4	Streaming feature set is not supported.	
5	GPL feature set is supported.	
6	WRITE DMA FUA EXT and WRITE MULTIPLE FUA EXT commands are supported.	
7	WRITE DMA QUEUED FUA EXT command is not supported.	
8	64-bit World Wide Name is supported.	
9-10	Obsolete.	
11-12	Reserved for TLC.	
13	IDLE IMMEDIATE command with IUNLOAD feature is supported.	
14	Shall be set to 1.	
15	Shall be cleared to 0.	
Bit	Word 88	
0	Ultra DMA mode 0 is supported.	
1	Ultra DMA mode 1 is supported.	
2	Ultra DMA mode 2 is supported.	
3	Ultra DMA mode 3 is supported.	
4	Ultra DMA mode 4 is supported.	
5	Ultra DMA mode 5 is supported.	
6	Ultra DMA mode 6 is supported.	
8	Ultra DMA mode 0 is currently active.	
9	Ultra DMA mode 1 is currently active.	
10	Ultra DMA mode 2 is currently active.	
11	Ultra DMA mode 3 is currently active.	
12	Ultra DMA mode 4 is currently active.	
13	Ultra DMA mode 5 is currently active.	
14	Ultra DMA mode 6 is currently active.	

4.3.2 Identify Device Data log

The IDENTIFY DEVICE Data log (log 30H) transfers information about the drive. The data is organized as a set of 512-byte blocks of data, whose contents are shown in [Table 2 on page 7](#). All reserved bits or words should be set to zero. Parameters listed with an “x” are drive-specific or vary with the state of the drive.

The following may contain drive-specific features that may be included in the Serial ATA specification.

Table 9 Identify Device Data log

Page (hex)	QWord Offset (dec)	Bits	Description	Value (hex)
00	List of supported pages			
	0..7	63:24	Reserved	
		23:16	Page number	00
		15:0	Revision number	0001
	8		Number of entries in the following list	09
	9		Page number of the 1st supported ID data log page	00
	10		Page number of the 2nd supported ID data log page	01
	11		Page number of the next supported ID data log page	02
	12		Page number of the next supported ID data log page	03
	13		Page number of the next supported ID data log page	04
	14		Page number of the next supported ID data log page	05
	15		Page number of the next supported ID data log page	06
	16		Page number of the next supported ID data log page	08
	17		Page number of the last supported ID data log page	00
18..511		Reserved		
01	Copy of IDENTIFY DEVICE data			
	0..511		Copy of IDENTIFY DEVICE command data	

Table 9 Identify Device Data log (Continued)

02	Capacity			
	0..7	Capacity page information header (QWord)		
		63	Shall be set to 1	1
		62:24	Reserved	
		23:16	Page number	02
		15:0	Revision number	0001
	8..15	Device Capacity (QWord)		
		63	Shall be set to 1	1
		62:48	Reserved	0
		47:0	accessible capacity	65DE00000 - (512E) CBBC0000 - (4KN)
	16..23	Physical/Logical Sector Size (QWord)		
		63	Contents of the QWord are valid	1
		62	logical to physical sector relationship supported	1 (512E) / 0 (4KN)
		61	logical sector size supported bit	1 (4KN) / 0 (512E)
		60:22	Reserved	0
		19:16	logical to physical sector relationship	0 (4KN) / 3 (512E)
	24..31	Logical Sector Size (QWord)		
		63	Contents of the QWord are valid	1
		62:32	Reserved	0
		31:0	Logical Sector Size	4096b (4KN)
	32..39	Nominal Buffer Size (QWord)		
		63	Contents of the QWord are valid	1
		62:0	buffer size	256
	40..511		Reserved	0
03	Supported Capabilities			
	0..7	Supported Capabilities page information header (QWord)		
		63	Shall be set to 1	1
		62:24	Reserved	
		23:16	Page number	03
	8..15	Supported Capabilities (QWord)		
		63	Shall be set to 1	1
		62:55	Reserved	0
54		advanced background operation supported	0	
53	persistent sense data reporting	0		

Table 9 Identify Device Data log (Continued)

03	52	sff-8447 reporting	1
	51	definitive ending pattern supported	1
	50	data set management xl supported	0
	49	set sector configuration supported	1
	48	zero ext supported	0
	47	successful ncq command sense data supported	0
	46	dlc supported	0
	45	request sense device default supported	1
	44	dsn supported	1
	43	low power standby supported	0
	42	set epc power source supported	0
	41	amax addr supported	1
	40	Reserved for CFA	0
	39	drat supported	0
	38	lps misalignment reporting supported	0
	37	Reserved	0
	36	read buffer dma supported	0
	35	write buffer dma supported	0
	34	Reserved	0
	33	download microcode dma supported	0
	32	28-bit supported	0
	31	rzat supported	0
	30	Reserved	0
	29	nop supported	0
	28	read buffer supported	1
	27	write buffer supported	1
	26	Reserved	0
	25	read look-ahead supported	1
	24	volatile write cache supported	1
	23	smart supported	1
	22	flush cache ext supported	1
	21	Reserved	0
20	48-bit supported	1	
19	Reserved	1	
18	spin-up supported	1	
17	puis supported	1	
16	apm supported	0	

Table 9 Identify Device Data log (Continued)

		15	Reserved for CFA	0
		14	download microcode supported	1
		13	unload supported	1
		12	write fua ext supported	1
		11	gpl supported	1
		10	streaming supported	1
		9	Reserved	0
		8	smart self-test supported	1
		7	smart error logging supported	1
		6	epc supported	1
		5	sense data supported	1
		4	free-fall supported	0
		3	dm mode 3 supported	1
		2	gpl dma supported	1
		1	write uncorrectable supported	1
	0	wrv supported	1	
03	16..23	DOWNLOAD MICROCODE Capabilities (QWord)		
		63	Contents of the QWord are valid	1
		62:36	Reserved	0
		35	dm clears nonactivated deferred data	0
		34	dm offsets deferred supported	1
		33	dm immediate supported	1
		32	dm offsets immediate supported	1
		31:16	dm maximum transfer size	0000 _H
		15:0	dm minimum transfer size	0000 _H
	24..31	Nominal Media Rotation Rate (QWord)		
		63	Shall be set to one	1
		62:16	Reserved	0
		15:0	nominal media rotation rate	7200
	32..39	Form Factor (QWord)		
		63	Contents of the QWord are valid	1
62:4		Reserved	0	
3:0		nominal form factor	3.5"	
40..47	Write-Read-Verify Sector Count Mode 3 (QWord)			
	63	Contents of the QWord are valid	1	
	62:32	Reserved	0	
	31:0	wrm mode 3 count	0	

Table 9 Identify Device Data log (Continued)

03	48..55	Write-Read-Verify Sector Count Mode 2 (QWord)		
		63	Contents of the QWord are valid	1
		62:32	Reserved	0
		31:0	wrm mode 2 count	0
	56..71	World wide name (DQWord)		
		127	Shall be set to one	1
		126:64	Reserved	0
		63:0	world wide name	unique
	72..79	DATA SET MANAGEMENT (QWord)		
		63	Shall be set to one	1
		62:32	Reserved	0
		31:16	max pages per dsm command	0
		15:8	logical block markups supported	0
		7:1	Reserved	0
		0	trim supported	0
	80..95	Utilization Per Unit Time (DQWord)		
		127	Shall be set to one	1
		126:120	Reserved	0
		119:112	utilization type	Combined Writes and Reads
		111:104	utilization units	TB
		103:96	utilization interval	Per Year
		95:34	Reserved	0
		31:0	utilization a	550
	96..103	Utilization Usage Rate Support (QWord)		
		63	Contents of the QWord are valid	0
		62:24	Reserved	0
		23	setting rate basis supported	0
		22:9	Reserved	0
		8	since power on rate basis supported	0
		7:5	Reserved	0
4		power on hours rate basis supported	0	
3:1		Reserved	0	
0		date/time rate basis supported	0	

Table 9 Identify Device Data log (Continued)

03	104..111	Zoned Capabilities (QWord)		
		63	Contents of the QWord are valid	0
		62:2	Reserved	0
		1:0	zoned	0
	112..119	Supported ZAC Capabilities (QWord)		
		63	Contents of the QWord are valid	0
		62:5	Reserved	0
		4	non-data reset write pointers ext supported	0
		3	non-data finish zone ext supported	0
		2	non-data close zone ext supported	0
		1	non-data open zone ext supported	0
	0	report zones ext supported	0	
	120..127	Advanced Background Operations Capabilities (QWord)		
		63	Contents of the QWord are valid	0
		62	abo foreground mode supported	0
		61	abo ir mode supported	0
		60:48	Reserved	0
		47:16	abo minimum fraction	0
	15:0	abo minimum supported timelimit	0	
	128..135	Advanced Background Operations Recommendations (QWord)		
		63	Contents of the QWord are valid	0
		62:32	Reserved	0
		31:16	device maintenance polling time	0
	15:0	abo recommended abo start interval	0	
	136..143	Queue Depth (QWord)		
		63	Contents of the QWord are valid	0
		62:5	Reserved	0
		4:0	queue depth	0

Table 9 Identify Device Data log (Continued)

03	144..151	Supported SCT Capabilities (QWord)		
		63	Contents of the QWord are valid	0
		62:27	Reserved	0
		26	sct write same function 103 supported	0
		25	sct write same function 102 supported	0
		24	sct write same function 101 supported	0
		23:19	Reserved	0
		18	sct write same function 3 supported	0
		17	sct write same function 2 supported	0
		16	sct write same function 1 supported	0
		15:6	Reserved	0
		5	sct data tables supported	0
		4	sct feature control supported	0
		3	sct error recovery control supported	0
		2	sct write same supported	0
		1	Reserved	0
		0	sct supported	0
152..159	Depopulation Capabilities (QWord)			
	63	Contents of the QWord are valid	1	
	62:2	Reserved	0	
	1	get physical element status supported	1	
160..167	35	Depopulation Execution Time (QWord)		
		Bit Description: 63 Contents of the QWord are valid		
		62:0	DEPOPULATION TIME field (see 9.10.5.19)	E62A _H
168..503	Reserved			
504..511	Vendor Specific Supported Capabilities (QWord)			
	63	Contents of the QWord are valid	0	
	62:0	Vendor specific		

Table 9 Identify Device Data log (Continued)

04	Current Settings			
	0..7	Current Settings page information header (QWord)		
		63	Shall be set to 1	1
		62:24	Reserved	0
		23:16	Page number	04
	8..15	Current Settings (QWord)		
		63	Shall be set to one	1
		62:19	Reserved	0
		18	successful ncq command sense data enabled	0
		17	dlc enabled	0
		16	dsn enabled	0
		15	epc enabled	1
		14	Reserved	0
		13	volatile write cache enabled	1
		12	Reserved	0
		11	reverting to defaults enabled	0
		10	sense data enabled	0
		9	Reserved	0
		8	non-volatile write cache	0
		7	read look-ahead	1
		6	smart enabled	1
		5	Reserved	0
		4	Reserved	0
	3	puis enabled	0	
	2	apm enabled	0	
	1	free-fall enabled	0	
	0	wrv enabled	0	
	16..23	Feature Settings (QWord)		
		63	Contents of the QWord are valid	1
		62:18	Reserved	0
		17:16	power source	0
		15:8	apm level	0
		7:0	wrv mode	0

Table 9 Identify Device Data log (Continued)

04	24..31	DMA Host Interface Sector Times (QWord)		
		63	Contents of the QWord are valid	1
		62:16	Reserved	0
		15:0	dma sector time	0
	32..39	PIO Host Interface Sector Times (QWord)		
		63	Contents of the QWord are valid	1
		62:16	Reserved	0
		15:0	pio sector time	0
	40..47	Streaming Minimum Request Size (QWord)		
		63	Contents of the QWord are valid	1
		62:16	Reserved	0
		15:0	stream min request size	1000 _H
	48..55	Streaming Access Latency (QWord)		
		63	Contents of the QWord are valid	1
		62:16	Reserved	0
		15:0	stream access latency	0
	56..63	Streaming Performance Granularity (QWord)		
		63	Contents of the QWord are valid	1
		62:16	Reserved	0
		15:0	stream granularity	2710 _H
	64..71	Free-fall Control Sensitivity (QWord)		
		63	Contents of the QWord are valid	1
		62:16	Reserved	0
		15:0	free-fall sensitivity	0
	72..79	Device Maintenance Schedule (QWord)		
		63	Contents of the QWord are valid	0
		62:58	Reserved	0
57:48		minimum inactive time in milliseconds	0	
47:32		time scheduled for device maintenance	0	
31:16		time to performance degradation	0	
15:0		minimum inactive time	0	
80..87	Advanced Background Operations Settings (QWord)			
	63	Contents of the QWord are valid	0	
	62:8	Reserved	0	
	7:0	abo_status	0	
88..511	Reserved			

Table 9 Identify Device Data log (Continued)

05	Strings			
	0..7	Supported Capabilities page information header (QWord)		
		63	Shall be set to 1	1
		62:24	Reserved	
		23:16	Page number	05
	8..27	SERIAL NUMBER (ATA String)	XXXXXXXX _H	
	28..31	Reserved		
	32..39	FIRMWARE REVISION (ATA String)	XXXX _H	
	40..47	Reserved		
	48..87	MODEL NUMBER (ATA String)	ST16000VE000 ST14000VE0008 ST12000VE0008 ST10000VE0008	
	88..95	Reserved		
96..103	ADDITIONAL PRODUCT IDENTIFIER (ATA String)	0		
104..511	Reserved			
06	Security			
	0..7	Security page information header (QWord)		
		63	Shall be set to 1	1
		62:24	Reserved	
		23:16	Page number	06
	8..15	Master Password Identifier (QWord)		
		63	Contents of the QWord are valid	1
		62:16	Reserved	0
	16..23	15:0	master password identifier	FFFE _H
		Security Status (QWord)		
		63	Contents of the QWord are valid	1
		62:7	Reserved	0
		6	security supported	1
		5	master password capability	0
		4	enhanced security erase supported	1
		3	security count expired	0
		2	security frozen	0
1		security locked	0	
0	security enabled	0		

Table 9 Identify Device Data log (Continued)

06	24..31	Time required for an Enhanced Erase mode SECURITY ERASE UNIT command (QWord)		
		63	Contents of the QWord are valid	1
		62:16	Reserved	0
		15	enhanced security erase time format	1
		14:0	enhanced security erase time	245 _H
	32..39	Time required for an Normal Erase mode SECURITY ERASE UNIT command (QWord)		
		63	Contents of the QWord are valid	1
		62:16	Reserved	0
		15	normal security erase time format	1
	40..47	Trusted Computing Feature Set (QWord)		
		63	Contents of the QWord are valid	1
		62:1	Reserved	0
	48..55	Security Capabilities (QWord)		
		63	Contents of the QWord are valid	1
		62:8	Reserved	0
		7	restricted sanitize overrides security	0
		6	acs-3 commands allowed by sanitize	1
		5	sanitize antifreeze lock supported	1
		4	block erase supported	0
		3	overwrite supported	1
2		crypto scramble supported	0	
1		sanitize supported	1	
0	encrypt all supported	0		
56..511	Reserved			
07	Parallel ATA			
	000..511	(Not supported for SATA drives)	all zeros	

Table 9 Identify Device Data log (Continued)

08	Serial ATA			
	0..7	Serial ATA page information header (QWord)		
		63	Shall be set to 1	1
		62:24	Reserved	
		23:16	Page number	08
	8..15	SATA Capabilities		
		63	Shall be set to one	1
		62:32	Reserved	0
		31	power disable feature always enabled	0
		30	power disable feature supported	0
		29	rebuild assist supported	0
		28	dipm ssp preservation supported	0
		27	hybrid information supported	0
		26	devsleep to reducedpwrstate capability supported	0
		25	device sleep supported	0
		24	ncq autosense supported	1
		23	software settings preservation supported	1
		22	hardware feature control supported	0
		21	in-order data delivery supported	0
20		device initiated power management supported	1	
19	dma setup auto-activation supported	1		
18	nonzero buffer offsets supported	0		
17	send and receive queued commands supported	1		

Table 9 Identify Device Data log (Continued)

08	16..23	16	ncq non-data command supported	1	
		15	ncq streaming supported	0	
		14	read log dma ext as equivalent to read log ext supported	1	
		13	device automatic partial to slumber transitions supported	0	
		12	host automatic partial to slumber transitions supported	0	
		11	ncq priority information supported	0	
		10	unload while ncq commands are outstanding supported	1	
		9	sata phy event counters log supported	1	
		8	receipt of host initiated power management requests supported	0	
		7	ncq feature set supported	1	
		6:3	Reserved	0	
		2	sata gen3 signaling speed supported	1	
		1	sata gen2 signaling speed supported	1	
		0	sata gen1 signaling speed supported	1	
		Current SATA Settings (QWord)			
		63	Shall be set to one	1	
		62:14	Reserved	0	
		13	hybrid enabled	0	
		12	rebuild assist enabled	0	
		11	power disable feature enabled	0	
		10	device sleep enabled	0	
		9	automatic partial to slumber transitions enabled	0	
		8	software settings preservation enabled	1	
		7	hardware feature control is enabled	0	
		6	in-order data delivery enabled	0	
		5	device initiated power management enabled	0	
		4	dma setup auto-activation enabled	1	
		3	nonzero buffer offsets enabled	0	
2:0	current negotiated serial ata signal speed	(6.0, 3.0, 1.5) Gb/s			

Table 9 Identify Device Data log (Continued)

08	24..39	Reserved		
	40..41	CURRENT HARDWARE FEATURE CONTROL IDENTIFIER (Word)		
	42..43	SUPPORTED HARDWARE FEATURE CONTROL IDENTIFIER (Word)		
	44..47	Reserved		
	48..55	Device Sleep Timing Variables (QWord)		
		63	devslp timing variables supported	0
		62:16	Reserved	0
		15:8	devsleep exit timeout (deto)	0
		7:5	Reserved	0
	4:0	minimum devslp assertion time (mdat)	0	
56..511	Reserved			

4.3.3 Device Statistics log

The Device Statistics log (log 04H) transfers information about the drive. The data is organized as a set of 512-byte blocks of data, whose contents are shown in [Table 2 on page 7](#). All reserved bits or words should be set to zero. Parameters listed with an “x” are drive-specific or vary with the state of the drive.

The following may contain drive-specific features that are included in the SATA specifications.

Table 10 Device Statistics log

Page (hex)	Statistic	Supported
00	List of supported log pages	Yes
01	General Statistics	
	Lifetime Power-on Resets	Yes
	Power-on Hours	Yes
	Logical Sectors Written	Yes
	Number of Write Commands	Yes
	Logical Sectors Read	Yes
	Number of Read Commands	Yes
	Pending Error Count	x
	Workload Utilization	No
	Utilization Usage Rate	No
	Resource Availability	x
	Random Write Resources Used	x
02	Free Fall Statistics	
	Number of Free-Fall Events Detected	No
	Overlimit Shock Events	No
03	Rotating Media Statistics	
	Spindle Motor Power-on Hours	Yes
	Head Flying Hours	Yes
	Head Loaded Events	Yes
	Number of Reallocated Logical Sectors	Yes
	Read Recovery Attempts	Yes
	Number of Mechanical Start Failures	Yes
	Number of Reallocation Candidate Logical Sectors	Yes
Number of High Priority Unload Events	Yes	
04	General Errors Statistics	
	Number of Reported Uncorrectable Errors	Yes
	Number of Resets Between Command Acceptance and Command Completion	Yes
	Physical Element Status Changed	x

Table 10 Device Statistics log

05	Temperature Statistics	
	Current Temperature	Yes
	Average Short Term Temperature	Yes
	Average Long Term Temperature	Yes
	Highest Temperature	Yes
	Lowest Temperature	Yes
	Highest Average Short Term Temperature	Yes
	Lowest Average Short Term Temperature	Yes
	Highest Average Long Term Temperature	Yes
	Lowest Average Long Term Temperature	Yes
	Time in Over-Temperature	Yes
	Specified Maximum Operating Temperature	Yes
	Time in Under-Temperature	Yes
	Specified Minimum Operating Temperature	Yes
06	Transport Statistics	
	Number of Hardware Resets	Yes
	Number of ASR Events	Yes
	Number of Interface CRC Errors	Yes
07	Solid State Device Statistics	
	Percentage Used Endurance Indicator	No
08	Zoned Device Statistics	
	Maximum Open Zones	No
	Maximum Explicitly Open Zones	No
	Maximum Implicitly Open Zones	No
	Minimum Empty Zones	No
	Maximum Non Sequential Zones	No
	Zones Emptied	No
	Suboptimal Write Commands	No
	Commands Exceeding Optimal Limit	No
	Failed Explicit Opens	No
	Read Rule Violations	No
	Write Rule Violations	No
09..FE	Reserved	
FF	Vendor Specific Statistics	
	TBD	x

4.3.4 Set Features command

This command controls the implementation of various features that the drive supports. When the drive receives this command, it sets BSY, checks the contents of the Features register, clears BSY and generates an interrupt. If the value in the register does not represent a feature that the drive supports, the command is aborted. Power-on default has the read look-ahead and write caching features enabled. The acceptable values for the Features register are defined as follows:

Table 11 Set Features command values

02 _H	Enable write cache (<i>default</i>).
03 _H	Set transfer mode (based on value in Sector Count register). Sector Count register values:
00 _H	Set PIO mode to default (PIO mode 2).
01 _H	Set PIO mode to default and disable IORDY (PIO mode 2).
08 _H	PIO mode 0
09 _H	PIO mode 1
0A _H	PIO mode 2
0B _H	PIO mode 3
0C _H	PIO mode 4 (<i>default</i>)
20 _H	Multiword DMA mode 0
21 _H	Multiword DMA mode 1
22 _H	Multiword DMA mode 2
40 _H	Ultra DMA mode 0
41 _H	Ultra DMA mode 1
42 _H	Ultra DMA mode 2
43 _H	Ultra DMA mode 3
44 _H	Ultra DMA mode 4
45 _H	Ultra DMA mode 5
46 _H	Ultra DMA mode 6
10 _H	Enable use of SATA features
55 _H	Disable read look-ahead (read cache) feature.
82 _H	Disable write cache
90 _H	Disable use of SATA features
AA _H	Enable read look-ahead (read cache) feature (<i>default</i>).
F1 _H	Report full capacity available

NOTE

At power-on, or after a hardware or software reset, the default values of the features are as indicated above.

4.3.5 S.M.A.R.T. commands

S.M.A.R.T. provides near-term failure prediction for disk drives. When S.M.A.R.T. is enabled, the drive monitors predetermined drive attributes that are susceptible to degradation over time. If self-monitoring determines that a failure is likely, S.M.A.R.T. makes a status report available to the host. Not all failures are predictable. S.M.A.R.T. predictability is limited to the attributes the drive can monitor. For more information on S.M.A.R.T. commands and implementation, see the *Draft ATA-5 Standard*.

SeaTools diagnostic software activates a built-in drive self-test (DST S.M.A.R.T. command for D4_H) that eliminates unnecessary drive returns. The diagnostic software ships with all new drives and is also available at: <http://www.seagate.com/support/downloads/seatools/>.

This drive is shipped with S.M.A.R.T. features disabled. Users must have a recent BIOS or software package that supports S.M.A.R.T. to enable this feature. The table below shows the S.M.A.R.T. command codes that the drive uses.

Table 12 S.M.A.R.T. commands

Code in features register	S.M.A.R.T. command
D0 _H	S.M.A.R.T. Read Data
D2 _H	S.M.A.R.T. Enable/Disable Attribute Autosave
D3 _H	S.M.A.R.T. Save Attribute Values
D4 _H	S.M.A.R.T. Execute Off-line Immediate (runs DST)
D5 _H	S.M.A.R.T. Read Log Sector
D6 _H	S.M.A.R.T. Write Log Sector
D8 _H	S.M.A.R.T. Enable Operations
D9 _H	S.M.A.R.T. Disable Operations
DA _H	S.M.A.R.T. Return Status

NOTE

If an appropriate code is not written to the Features Register, the command is aborted and 0x04 (abort) is written to the Error register.



Seagate Technology LLC

AMERICAS Seagate Technology LLC 47488 Kato Road, Fremont, California 94538, United States, 510-661-1000

Publication Number: 100855892, Rev. D
May 2020