

iD.FREE / iD.TRI
**USER
GUIDE**



Contents

1	Introduction	3
1.1	Button functions	3
1.2	First start	3
1.3	Carry out training	4
1.4	Wrist-based heart rate	4
1.5	Using target zones and smart light	5
1.6	Custom sport profiles	5
1.7	Connecting sensors / smart phone	6
1.8	Charging the device	6
1.9	Assembly instructions (incl. "Sensor assembly")	7
2	Calibration	8
2.1	Calibrating altitude sensor	8
2.2	Calibrating the compass	8
2.3	Setting and calibrating the power meter	8
3	Navigation	9
3.1	Loading the tracks on the device and navigate	9
3.2	Komoot Connect Navigation	9
4	Geocaching (iD.FREE)	10
5	Workouts (iD.TRI)	10
6	Competitions (iD.TRI)	11
7	Maintenance of your watch	11
8	Settings	12
8.1	Device settings	12
8.2	User settings	13
9	Technical information	13
9.1	Specifications	13
9.2	More information	14
9.3	EU Declaration of Conformity	14
9.4	Warranty	14
9.5	Disposal	14

1 Introduction

1.1 Button functions



1.2 First start

Press and hold the Start button for 5 s

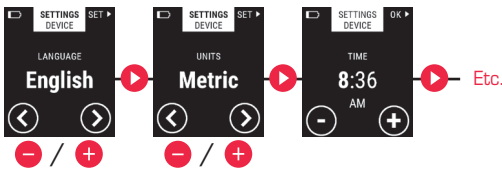
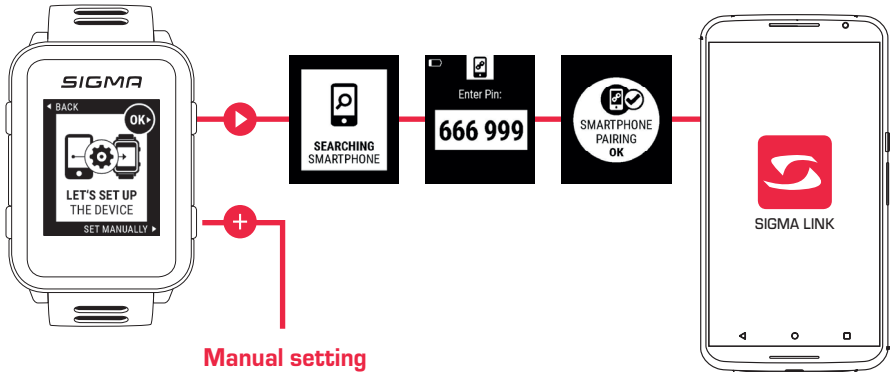

Please follow instructions in the SIGMA LINK app

1.3 Carry out training

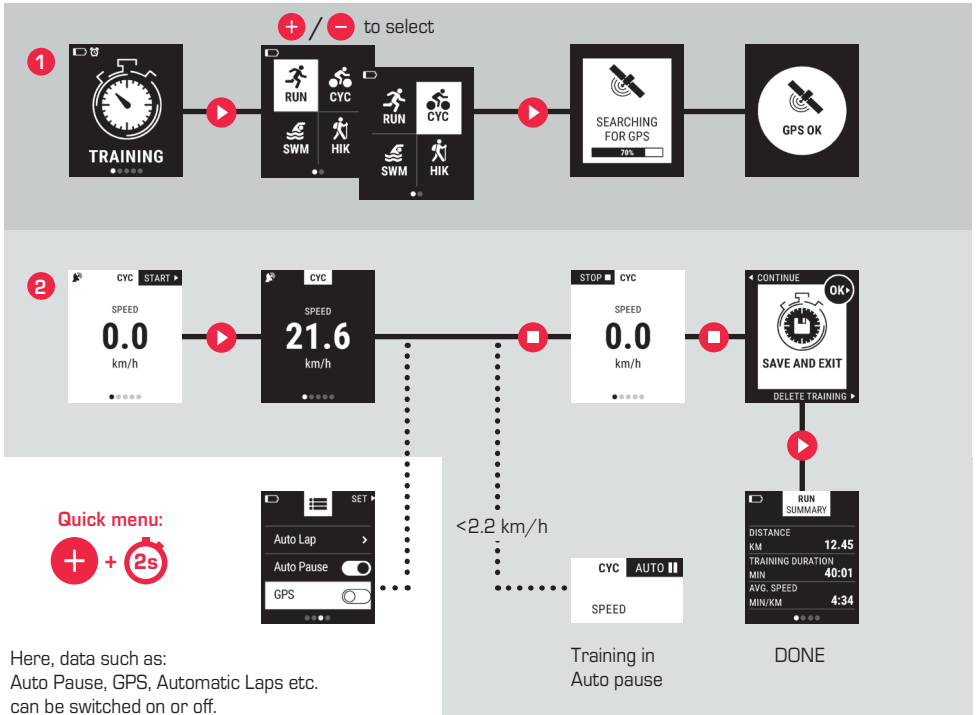

Here, data such as: Auto Pause, GPS, Automatic Laps etc. can be switched on or off.

1.4 Wrist-based heart rate

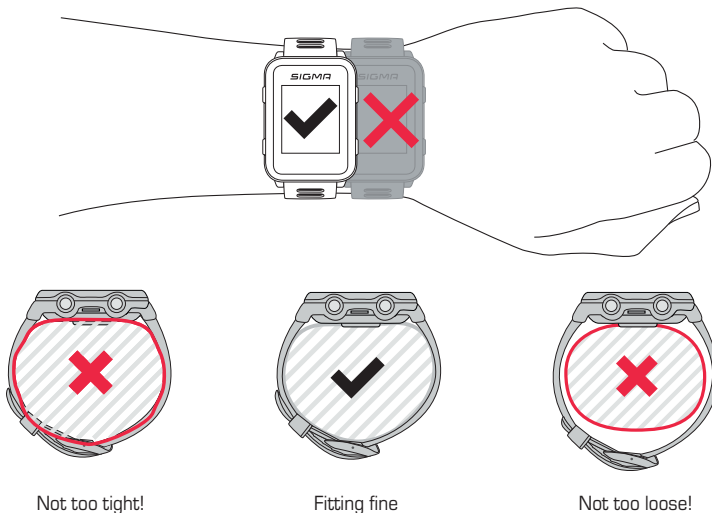

1.5 Using target zones and smart light

With iD.FREE/iD.TRI you have the option to define target zones. These can be based on heart rate or speed. Only one target zone is possible at a time.

To train for a target zone, you have two options:

1. You set the target zone for the sport profile in the DATA CENTER or the LINK app.
2. While training, open the quick menu (press and hold the "+" button for 2 s), select "Target zone" and set the target zone.

The smart light will then indicate if you are below (blue), in (green), or above (red) the target zone.

In addition, you can use the DATA CENTER or the LINK app to set up the target zone as a training value for your sports profile.

1.6 Custom sport profiles

The iD.FREE/iD.TRI has the so-called "sport profiles". These help you to link the different settings with the chosen sport. If you change the sport profile, functions such as the training views and the settings for the Automatic Pause are automatically set. Once set, there is no more need to check the settings.

You can access the most important sport profile settings during the training session. For this purpose, open the quick menu (press and hold the "+" button for 2 seconds) and change to the desired setting.

The display views and other basic settings can be changed only via DATA CENTER or LINK app. To do this, connect your watch to the DATA CENTER or the LINK app. Select "Sport profiles" and set the desired sport profile.

1.7 Connecting sensors / smart phone

If you use a sensor that offers both ANT+ and BLE, you will get this sensor twice during the search. You only need to connect the sensor to the watch once! If the connection to the sensors break off during the training, you can restore it via the quick menu:

- ▶ Press the "+" button for 2 s
- ▶ Select "Search sensor"
- ▶ The watch now searches for all connected sensors and connects them

BLE sensors / ANT+ sensors

- ▶ Go into area where no other sensors are active
- ▶ Activate sensors
- ▶ In the watch, go to Settings > Connection > Sensors > Search sensors
- ▶ Available sensors are displayed
- ▶ Start pairing in the watch
- ▶ Sensor is paired

Connect smart phone

- ▶ Only one smart phone can be paired at a time
- ▶ Turn on Bluetooth in the smart phone
- ▶ In the watch go to Settings > Connection > Smart phone > Find new smart phone
- ▶ In the app, initiate pairing, for this go to the LINK app on "My devices"

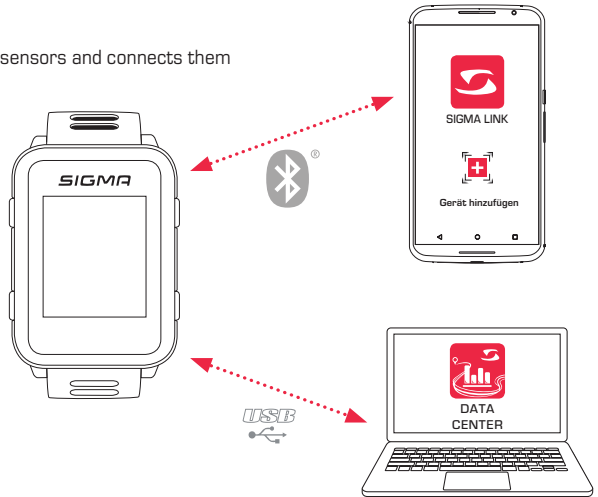

1.8 Charging the device

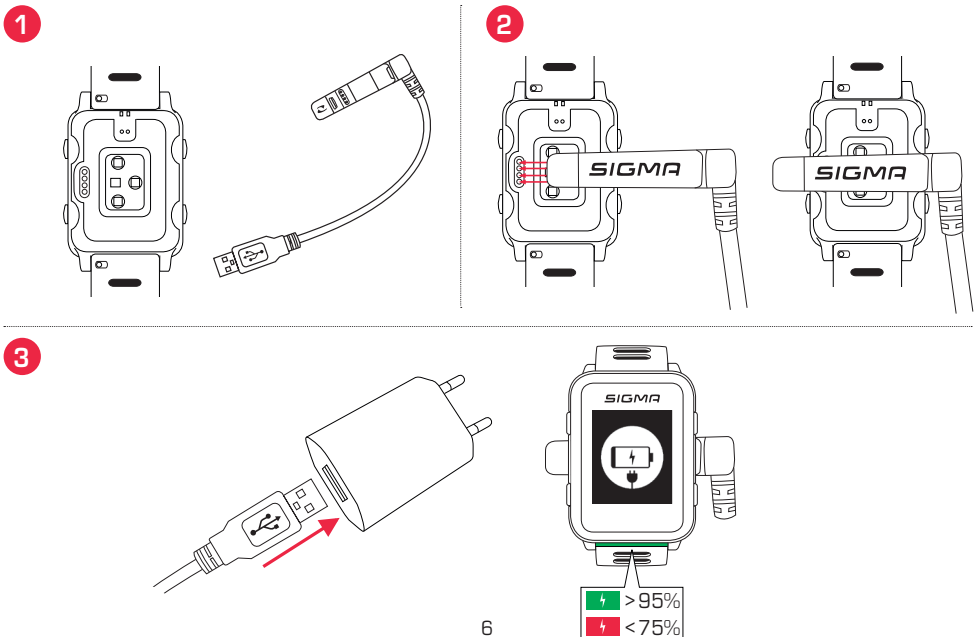

1.9 Assembly instructions: SnapOn Bike Mount assembly

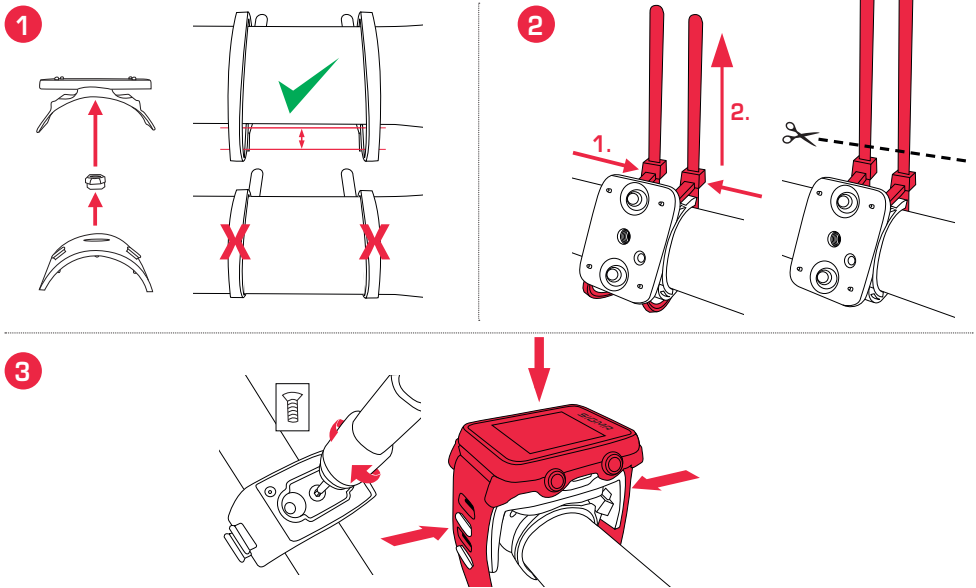

Sensor assembly

Only included in the iD.TRI complete set:

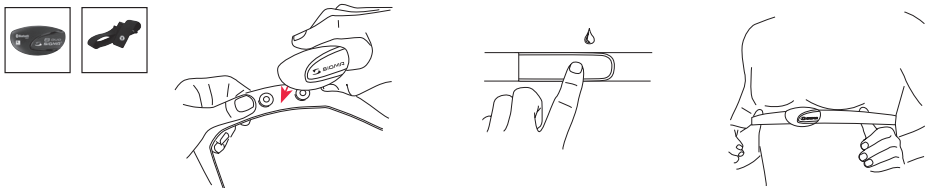
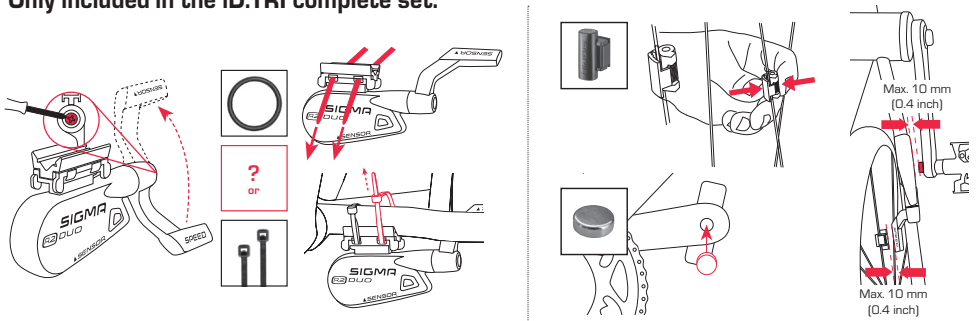

2 Calibration

2.1 Calibrating altitude sensor

The altitude measurement of the iD.FREE / iD.TRI is determined on the basis of the barometric air pressure. Any change to the weather means a change to the air pressure, which can lead to a change to your current altitude. To offset these changes in air pressure, you must enter a reference altitude into the iD.FREE / iD.TRI (process known as calibration).

The watches offer you three different types of calibration. To do this, open the quick menu at the beginning or during the training session:

1. Home

The home altitude is set in the device settings. Choose this value if you often start training at the same place.

2. GPS

If you do not have a reference point or any indication of your current altitude, you can calibrate this by means of GPS. The accuracy of the displayed altitude depends on the GPS receiver.

3. Manual calibration

Use this setting if you know the current altitude.

2.2 Calibrating the compass

In order for your track to be correctly aligned even when stationary, the compass must be calibrated at regular intervals. To do this, open the quick menu at the beginning or during the training session and select "Calibrating the compass". Follow the instructions on the display. Calibration works best if you turn by 360° with the watch on your arm.

2.3 Setting and calibrating the power meter

To set your power meter, first connect the power meter to the watch (as described in "Connecting sensors / smart phone"). Then select "Settings > Connection > Sensors > Connected sensors". If your power meter offers the corresponding setting options, you can then set the corresponding data (e.g. crank arm length) by pressing the "+" button. To do this, you must be near the power meter and it must be switched on / activated. If your power meter supports additional settings, please refer to the instructions of the manufacturer of the power meter.

To reset the power meter before or during the training session, do the following:

- ▶ Start a training in the CYC profile
- ▶ Open the quick menu (press and hold the "+" button for 2 seconds).
- ▶ Select "Power Meter Zero Off" and perform the procedure as specified by your power meter manufacturer. You see this menu item only when the power meter is connected. If you like to see the power values during the training, you have to adjust the CYC sport profile accordingly.

3 Navigation

3.1 Loading the tracks on the device and navigate

The track management can also be performed quickly and conveniently via the DATA CENTER. It is also possible to transfer already created tracks to the iD.FREE / iD.TRI very conveniently via the SIGMA LINK app. To do this, select the "Tracks" area in the DATA CENTER or the app and transfer the tracks to the device.

You can start a track from the main menu level. To do so, select the menu item "Loading track", select the desired sport profile and start the training session. The track will then be displayed on an extra screen.

Alternatively, you can start a track during a training session by opening the quick menu (press the "+" button for 2 s) and select "Loading track" from the list. Here you can also go back to the driven track.

3.2 Komoot Connect Navigation

iD.FREE and iD.TRI can display navigation instructions of the "Komoot" app. Here you can plan routes and let the application navigate.* The watch will then display the navigation instructions sent by the app on the smart phone. To use the Komoot navigation, proceed as follows:

Setup:

- ▶ Download Komoot app from the App Store or Google Play Store
- ▶ Create account and buy region
- ▶ Pair your smart phone with iD.FREE / iD.TRI via the SIGMA LINK app
- ▶ Open Komoot app
- ▶ In your profile settings, you can now connect the watch with the Komoot app under the item "Bluetooth Connect"

Navigate:

- ▶ Plan your route in the Komoot app
- ▶ Start the route
- ▶ Start a training on the iD.FREE / iD.TRI
- ▶ The navigation instructions are displayed on the device
- ▶ If you leave the route a recalculation will be done by Komoot, and the navigation instructions will be adjusted accordingly on the watch

*The desired region must be released.

4 Geocaching (iD.FREE)

To find a geocache with the iD.FREE you have two options:

1. You manually enter the GPS coordinates in the watch.
2. You select a geocache from your geocaching.com list. To do this, proceed as follows:

Setup:

- ▶ Download the Geocaching app from the App Store or Play Store
- ▶ Create an account (to use the geocache list you will need a premium account)
- ▶ Connect your SIGMA DATA CENTER or the SIGMA LINK app to your geocaching.com account. To do this, select "Geocaching" in the LINK app. In the DATA CENTER, you will find the connection on the home page, if your watch is connected to the DATA CENTER.
- ▶ Synchronize your geocaches in DATA CENTER or LINK app by clicking on "Update geocaches". You can find the caches under Games > Geocaching > Choose from list

Geocaching:

- ▶ Select a cache from its list or manually enter the cache and start the search.
- ▶ Before every search calibrate the compass for optimal search. This step starts automatically as soon as you start the geocaching search. If you have recently calibrated the compass, you can skip this step by pressing the Stop button.
- ▶ Use the arrow to navigate to the cache.
- ▶ You can find more information about the cache in the quick menu. Hold down the "+" button for 2 seconds (only available for geocaching.com cache).
- ▶ Once you have found the cache, press the Stop button.
- ▶ Now you can either end the search or select or define a new cache.

5 Workouts (iD.TRI)

Workouts can be created in 3 different ways:

1. In the SIGMA DATA CENTER

- ▶ Connect the watch to the PC. Open the SIGMA DATA CENTER
- ▶ Click on the watch and select "Workouts"
- ▶ Create your workouts
- ▶ Then select the workouts to be transferred
- ▶ To perform the workout, select "Workout" in the main menu of the watch. Then select the sport and start the training.

2. Using the SIGMA LINK app

- ▶ Connect your watch to your smart phone
- ▶ Open the SIGMA LINK app and select "Workouts"
- ▶ As with the DATA CENTER, you can now create and transfer workouts
- ▶ To perform the workout, select "Workout" in the main menu of the watch. Then select the sport and start the training.

3. Third-party providers

- ▶ As the watch can read the FIT format, you can also use workouts of other providers (such as training peaks). To do this, export the workout to the service of your choice as a FIT file. Connect the watch to the PC. Copy the FIT workout to the watch in the Workouts folder. If the workout complies with the FIT standards, it can be read by the watch.
- ▶ To perform the workout, select "Workout" in the main menu of the watch. Then select the sport and start the training.
- ▶ Alternatively, you can start a workout during a training. For this, open the quick menu and select Workout. Select and then start the desired workout. The data of the workout will then be displayed in a separate training screen. To cancel the current phase and switch to the next phase press and hold the start button for 2 seconds.

6 Competitions (iD.TRI)

You can use 2 different processes to start a competition on the watch.

1. Select a pre-installed competition from the list on the watch.
2. Create new competitions in the SIGMA LINK app or DATA CENTER and transfer them to the watch.

While creating, you can set whether the changeover time between the disciplines should also be stopped. The display views, basic settings and the drink and food alarms are created for the competitions based on the respective sport profile.

To switch to the next discipline in the competition, you also have 2 options.

1. Press and hold the start button for 2 s
2. Open the quick menu (press and hold "+" button for 2 s) and select "Transition zone".

7 Maintenance of your watch

We recommend cleaning the watch at regular intervals and in case of heavy soiling. Please use only mild cleaning agents. To obtain an ideal function, e.g. of the altitude sensor, regular cleaning of the watch is necessary. To clean the altitude sensor, it is best to put the watch in clear water for a few minutes, then rinse the watch again under running water. Never insert objects into the holes of the altitude sensor (at the back of the watch) as they may damage the sensor.

To clean the wrist strap, we recommend clear water, some detergent and a fine, soft brush. The contact points for the charging clamp can also be cleaned with a fine brush and water. Allow the watch to dry completely after cleaning. Never use the charging clamp with a wet watch.

8 Settings

8.1 Device settings

System settings	Description
Language	Set the desired language here.
Scale Units	Here you can choose between 2 settings for displaying the units: 1. Metric (centimeters, meters, etc.) 2. Imperial (foot, yard, miles, etc.)
Date	Setting for the current date
Clock	Set the time format (12H / 24H) and the current time
Alarm	Here you can set an alarm time. Choose whether you want to set the alarm time daily or only on weekdays.
Key Vibration	Turn the button vibration on or off.
Alerts	Turn Vibration and the Smart Light on or off for notifications.
Key Lock	Turn the button lock for the clock mode on or off.
Altitude	Here you can define a home altitude, which you can then use to calibrate the altitude in training.
Description	Switch on or off the value description for the fields in the training.
Watch	Change the time display and choose from the 3 different options: Digital, analog or race.
Sleep	If this option is switched on, the watch automatically returns to the time mode after a long period of inactivity. This setting does NOT affect the training mode.
Tracking	Turn Activity Tracking on or off.
Smart	Turn Smart Notifications on or off
Wrist	Indicate on which arm you are wearing the watch. This information is needed for some algorithms (e.g., swimming).
GPS	Here you can choose between ECO (lower power consumption, lower accuracy) and Normal (slightly higher power consumption, higher accuracy).
Reset Device	Reset the device to factory settings here. All files and settings are deleted.
Device Information	Here you will find information about the serial number, current firmware version and further information about the device.

8.2 Setting: user

User setting	Description
Gender	Indicate your sex.
Year	Enter your year of birth here. The data is used for various algorithms, e.g. calorie calculation.
Weight	Enter your current weight here.
Height	Here you can enter your height.
HR max	Indicate whether your maximum heart rate should be calculated based on your age or if you want to enter your own maximum heart rate (for example, from a performance diagnostics).

9 Technical information

9.1 Specifications

RF Interface F	Frequency range	Maximum RF output power	Number of channels
BLE	2402 – 2480 Mhz	4 dBm	39
ANT+	2457 MHz	0 dBm	1
GPS	1575.42 MHz	N / A	1
R1 ANT+ / BLE	2.4 GHz / 2.4 GHz	-6.31 dBm / 3.04 dBm	N / A
R2 ANT+ / BLE	2.4 GHz / 2.4 GHz	0.85 dBm / 3.81 dBm	N / A

Temperature range			
	iD.FREE / iD.TRI	R1 DUO	R2 DUO
Operating temperature:	-10°C – +50°C	-5°C – +50°C	-10°C – +60°C
Charging temperature:	0°C – +45°C		

Water resistance iD.FREE / iD.TRI = 5 ATM

9.2 More information

More information can be found here: www.sigma-qr.com



9.3 EU Declaration of Conformity

SIGMA-ELEKTRO GmbH hereby declares that the iD.FREE and iD.TRI comply with the essential requirements and other relevant provisions established in Directive 2014/53/EC. You can find the Declaration of Conformity at the following link:

ce.sigmasport.com/idfree

ce.sigmasport.com/idtri

9.4 Warranty

The guarantee for products of SIGMA-ELEKTRO GmbH is valid for 24 months from the date of invoice and covers mechanical or technical problems (display defects, data transfer problems, mounting, optical defects).

The guarantee applies only if the SIGMA SPORT products are used with accessories supplied or recommended by SIGMA SPORT. The guarantee does not apply to batteries, rechargeable batteries and wear parts (wrist straps, rubber straps, chest straps, etc.) as well as deliberate damage and defects caused by incorrect application.

SIGMA-ELEKTRO GmbH
Dr.-Julius-Leber-Straße 15
D-67433 Neustadt/Weinstraße
Service-Tel. +49-(0)6321-9120-118
E-mail: customerservice@sigmasport.com

You can find a complaints form on our website:

claim.sigmasport.com

The manufacturer retains the right to make technical modifications.

9.5 Disposal

Batteries must not be disposed of in household waste (German Battery Law - BattG)! Please take the batteries to an official collection point for disposal.



LI =
Lithium Ionen

Electronic devices must not be disposed of in household waste. Please take the device to an official waste collection point.

