



SFX-L Form Factor SX1000

1000W SFX-L fully modular 80 Plus Platinum power supply

SFX-L form factor for use in small form factor computers
1000W continuous power output rated for 24/7 operation

Class-leading single +12V rail with 83.4A

High efficiency with 80 PLUS Platinum certification

Silent running 120mm dual ball bearing fan with advanced semi-fanless operation

100% modular short cables with flexible flat arrays

Strict $\pm 3\%$ voltage regulation and low ripple & noise

24/7 continuous power output with 50°C operating temperature

High quality construction with all Japanese capacitors

SPECIFICATION

SFX-L Form Factor SST-SX1000-LPT

1000W Switching Power Supply With Active PFC 80Plus Platinum

This specification defines ATX multiple output switching power supply. The parameters of this supply are defined in this specification for Family using. This specification defines max continuous output at 1000W with 100 to 240Vac input, power supply with five outputs; +3.3V, +5V, +12V, -12V and +5VSB. The +5V standby voltage, remote on/off control, full range line input capability. An IEC connector is provided on the external face for AC input to the power supply. The power supply contains fans for cooling, while meeting acoustic requirements.

1. AC input characteristics:

1.1 AC input requirements:

The input voltage, current, and frequency requirements for continuous operation are stated show in Table 1.

Parameter	Min	Nom		Max	Unit
Vin	90	100	--- 240	264	VACrms
Vin Frequency	47	60	--- 50	63	Hz
lin		12	--- 6.0		A

1.2 AC inrush current(cold start):

The power supply must meet inrush requirements for any rated AC voltage, during turn on at any phase. of AC voltage, during a single cycle AC dropout condition, during repetitive ON/OFF cycling of AC, and over the specified temperature range .The peak inrush current shall be less than the ratings of its critical components (including input fuse, bulk rectifiers, and surge limiting device).

2. DC Output characteristics:

2.1 Output voltage regulation Requirements:

The power supply output voltage must stay within the following voltage limits shown in Table2 when operating at steady state.

Table2

Parameter	Range	Min	Nom.	Max	Unit
+3.3V	±3%	+3.20	+3.30	+3.39	Volts
+5V	±3%	+4.85	+5.0	+5.15	Volts
+12V	±3%	+11.64	+12.0	+12.36	Volts
-12V	±10%	-10.8	-12.0	-13.2	Volts
+5Vsb	±5%	+4.75	+5.0	+5.25	Volts

2.2 Output Current Requirements:

The power supply output current following shown in Table3.

Table3

Parameter	Min	Max	Peak	Unit
+3.3V	0	25		Amps
+5V	0	25		Amps
+12V	0	83.3		Amps
-12V	0	0.3		Amps
+5VSB	0	3		Amps

Notes:

1. The maximum continuous average DC output power shall not exceed 1000W.
2. Maximum continuous combined load on +3.3V and +5V outputs shall not exceed 125W.

2.3 Output Transient Response:

Table 4 summarizes the expected output transient step sizes for each output. The transient load slew rate is = 1.0 A/μs. +12V Min load 1A for 0%~85% load.

Table4

Parameter	Maximum Step Size (% of rated output amps)	Maximum Step Size (A)
+3.3V	30% load	
+5V	30% load	
+12V	85% load	
-12V		0.1A
+5VSB		0.5A

NOTES:

1. For example, for a rated +5 VDC output of 14A, the transient step would be $30\% \times 14 \text{ A} = 4.2 \text{ A}$.
2. Output voltages should remain within the regulation limits of Section 2.1, and the power supply should stabilize when subjected to load transients per Table 3. from any steady state load, including any or all of the following conditions:
3. Simultaneous load steps on the +12 VDC, +5 VDC, and +3.3 VDC outputs (all steps occurring in the same direction)
4. Load-changing repetition rate of 50 Hz to 10 kHz
5. AC input range per Section 1.1 and Capacitive loading per Table 8
6. The +12V min start load is 5Amin at dynamic load response test.

2.4 Output Ripple and Noise:

Table 5

Output	Ripple and Noise	Unit
+3.3V	50	mVp-p
+5V	50	mVp-p
+12V	120	mVp-p
-12V	120	mVp-p
+5VSB	50	mVp-p

NOTES:

This is measured over a bandwidth of 10Hz to 20MHz at the power supply output connector. A 10µF electrolytic capacitor in a parallel with a 0.1µF ceramic capacitor is placed at the point of measurement.

Differential noise test setup

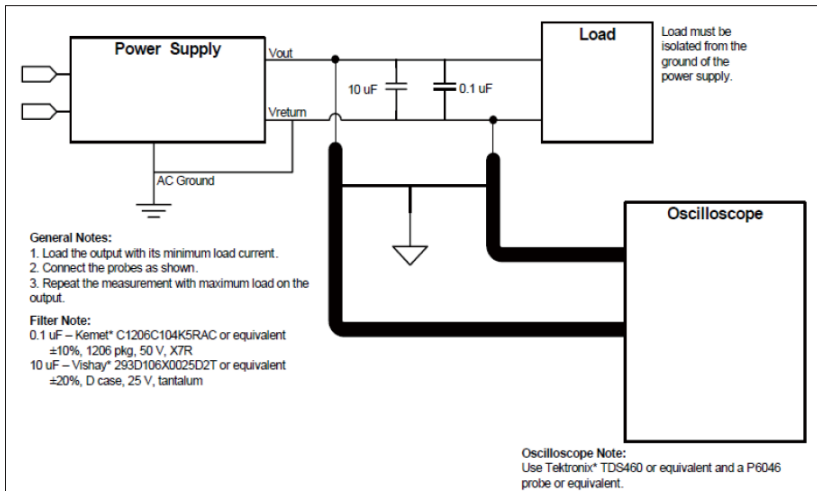

Figure 1

2.5 Efficiency:

2.5.1 In the 115Vac/60Hz input voltage the power supply efficiency is more than 94%.

Table6

Load	Efficiency(%)	Power Factor
10%	--	--
20%	90	--
50%	92	>0.95
100%	89	--

Note: There is a 1% tolerance in mass production

2.5.2 ERP 5VSB Efficiency

Table7

+5VSB LOAD	Efficiency target (both 110V and 230V input)
3A	75%
1.5A	75%
1A	75%
0.55A	75%
90mA	55%
45mA	45%

2.6 Remote on/off control

When the logic level "PS-ON" is low, the DC outputs are to be enabled.

When the logic level is high or open collector, the DC outputs are to be disabled.

2.7 Overshoot:

The overshoot of the DC output voltage caused by switching AC power or switch PSON# should be less than 10% of the normal output, and no reverse polarity voltage should be produced.

2.8 Capacitance Loading

The power supply shall be stable and meet all requirements with the following capacitive loading ranges.

Table8

Capacitive Loading Conditions	
Output	Capacitive Load (μ F)
+3.3V	3,300
+5V	3,300
+12V	3,300
-12V	3,30
+5VSB	3,300

3.Environment:

3.1 Operation temperature:

Table9

Temperature	0 to 50°C
Relative Humidity	5% to 90%,on - condensing

3.2 Shipping and Storage:

Table10

Temperature	-40°C~70°C
Relative Humidity	5% to 95%,non - condensing

3.3 Altitude:

Table11

Operating	≤2000m
Storage	≤3000m

3.4 Cooling mode:

Forced air cooling.

3.5 Random Vibration:

Non-operating 0.01 g²/Hz at 5 Hz, sloping to 0.02 g²/Hz at 20 Hz, and maintaining 0.02 g²/Hz from 20 Hz to 500 Hz. The area under the PSD curve is 3.13 grams. The duration shall be 10 minutes per axis for all three axes on all samples.

4. Protection:

Due to overvoltage, over power and short circuit, the protection function of the power supply circuit is self operated, and the power is self locked. There is no output at that time. When these reasons are removed, the power is restored to the normal output state when the power is restarted. (PSON# at least 1 second; AC shutdown at least 4 seconds).

4.1 Over-power protection.

The power supply will be shutdown and latch off when output power within 110~150% of rated DC output.

Note: Assurance machine can work at low voltage,full load won't damage machine.

4.2 Over voltage protection:

Table12

Output	Output voltage protection point			Unit
	Min	Nom	Max	
+3.3V	3.76	4.2	4.3	V
+5V	5.74	6.3	7.0	V
+12V	13.4	15.0	15.6	V
+5vsb	5.74	6.3	7.0	V

4.3 Short circuit protection:

An output short circuit is defined as any output impedance of less than 0.1 ohms. The power supply shall shut down and latch off for shorting the +3.3 VDC, +5 VDC, or +12VDC rails to return or any other rail. Shorts between main output rails and +5VSB shall not cause any damage to the power supply.

The power supply shall either shut down and latch off or fold back for shorting the negative rails. +5VSB must be capable of being shorted indefinitely, but when the short is removed, the power supply shall recover automatically or by cycling PS_ON#. The power supply shall be capable of withstanding a continuous short-circuit to the output without damage or overstress to the unit

4.4 Over Temperature Protection:

The power supply will be protected against over temperature conditions caused by loss of fan cooling or excessive ambient temperature. In an OTP condition the PSU will shutdown. When the power supply temperature drops to within specified limits, the power supply shall Latch mode.

4.5 Over current protection

The power supply shall have current limit to prevent the +3.3 V, +5 V, and +12V outputs from exceeding the values shown in Table . If the current limits are exceeded the power supply shall shutdown and latch off. The damaged from repeated power cycling in this condition. -12V and 5VSB shall be protected under over current or shorted conditions so that no damage can occur to the power supply. All outputs shall be protected so that no damage occurs to the power supply under a shorted output condition.

Table13

Voltage	Over Current Limit (Iout limit)
+3.3V	27.5A minimum; 37.5A maximum
+5V	27.5A minimum; 37.5A maximum
+12V	92A minimum; 125A maximum

5. Power Supply Timing

5.1 Signal timing drawing

Figure 2 is a reference for signal timing for main power connector signals and rails.

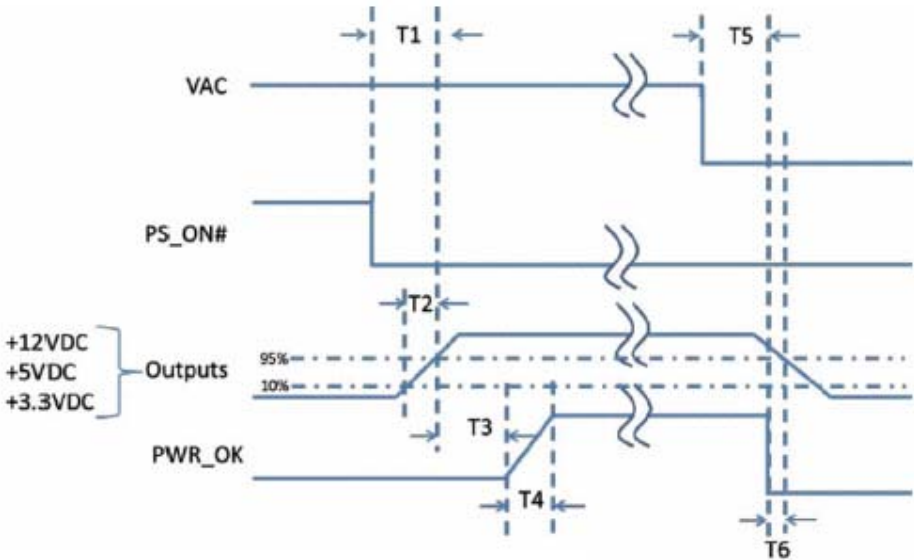

Figure 2

Table14

Parameter	Description	Required
T0	AC power on time	<2s
T1	Power-on time	< 200ms
T2	Rise time	0.2 – 20 ms
T3	PWR_OK delay	100 – 150ms
T4	PWR_OK rise time	< 10 ms
T5	AC loss to PWR_OK hold-up time	> 14 ms
T6	PWR_OK inactive to DC loss delay	> 1 ms

The power supply should maintain output regulations per Table 5 despite a loss of input power at the low-end nominal range-115 VAC / 47 Hz or 230 VAC / 47 Hz – at maximum continuous output load as applicable for a minimum of 17ms (T5+T6)

6. SAFETY:

The power supply designed to meet IEC 62368-1.

6.1 Electrical strength:

Gradually increased from 0V to 1500V is applied in the AC line and the casing, and then keep for 1 minutes, the insulation should not breakdown; if the current increases rapidly due to the test voltage and gets out of the way, that is to limit the current insulation, insulation breakdown that has occurred; corona discharge or flashover is not a single moment that is the breakdown of insulation.

6.2 Ground Resistance:

Ground resistance value less than $< 0.1 \text{ ohm}(40\text{A})$

6.3 Touch current:

When the input 250Vac, contact current less than 3.5mA at 25°C.

6.4 EMC

6.4.1 ELECTROSTATIC DISCHARGE (ESD) – IEC 61000-4-2(EN 61000-4-2).

6.4.2 RADIATED SUSCEPTIBILITY – IEC 61000-4-3(EN 61000-4-3).

6.4.3 ELECTRICAL FAST TRANSIENT / BURST (EFT/B) – IEC 61000-4 -4 (EN 61000-4-4).

6.4.4 SURGE – IEC 61000-4-5(EN 61000-4-5).

6.4.5 CONDUCTED SUSCEPTIBILITY – IEC 61000-4-6(EN 61000-4-6).

6.4.6 POWER FREQUENCY MAGNETIC FIELD – IEC 61000-4-8(EN 61000-4-8).

6.4.7 VOLTAGE DIPS – IEC 61000-4-11(EN 61000-4-11).

6.4.8 VOLTAGE FLUCTUATIONS – IEC 61000-3-3 (EN 61000-3-3).

6.4.9 HARMONIC CURRENT EMISSION – IEC61000-3-2(EN 61000-3-2).

6.4.10 EN55032:Class B Radio interference (CISPR 32).

6.4.11 ANSI C63.4-2014 / FCC Part 15 Subpart B / ICES-003 Issue 6 Class B 115VAC operation.

7. Reliability:

The demonstrated MTBF shall be 100,000 hours of continuous operation at 25°C and full load and nominal voltage. The MTBF of the power supply shall be calculated in accordance with MIL-HDBK-217F. The DC FAN is not included.

8. Mechanical:

8.1 Physical dimension: L125mm x W130mm x H63.5mm

9. POWER SUPPLY CONNECTOR OVERUSE DEFINITION

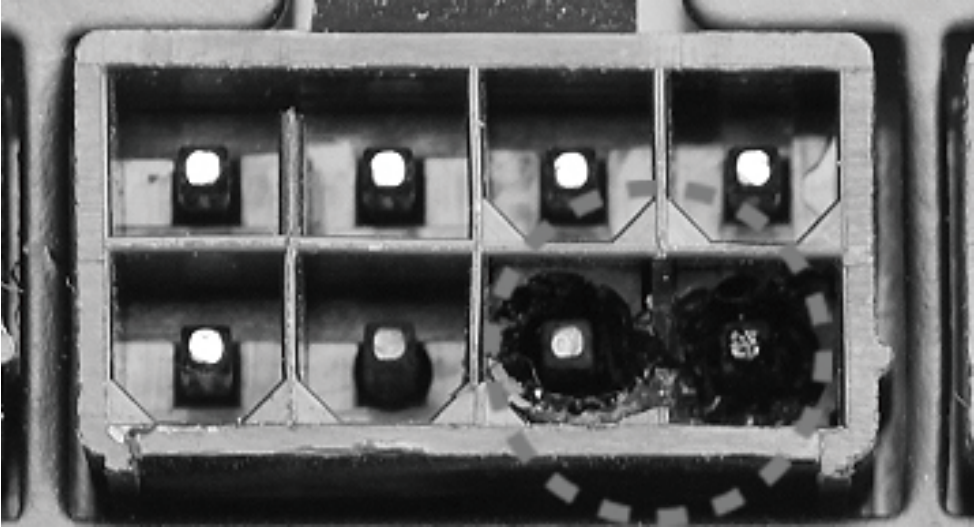

EN

Power supply connector overuse definition

A single PCIe 8pin cable and connector's maximum current rating is 12.5A, which is 150W (+12V x 12.5A). So SilverStone's warranty will not cover damages or malfunction resulting from the use of a graphics card or expansion card with a single PCIe 8pin connector that exceeds standard 225W total power draw (150W from PCIe 8pin connector + 75W from PCIe motherboard slot). Similarly, a graphics card or expansion card with dual PCIe 8pin connectors that exceed 375W total power draw (300W from two PCIe 8pin connectors + 75W from PCIe motherboard slot) will also not be covered under warranty.

Peripheral (molex) or SATA connector's maximum current rating is 5A, which is 60W (+12V x 5A) or 25W (+5V x 5A). Please ensure connected devices are operating under these limits. SilverStone's warranty will not cover damages or malfunction resulting from usages exceeding these connectors and their associated cables.

24pin motherboard connector's maximum current rating for its dual +12V metal pins are 5A each, which totals 120W (+12V x 5A x 2). Please ensure +12V drawing devices connected to the motherboard are operating under these limits. SilverStone's warranty will not cover damages or malfunction resulting from usages exceeding these connectors and their associated cables.

DE

Definition einer Überlastung des Netzanschlusses

Die maximale Stromstärke eines einzelnen 8-poligen PCIe-Kabels und Anschlusses beträgt 12,5 A, was 150 W (+12 V x 12,5 A) entspricht. Daher deckt die SilverStone-Garantie keine Schäden oder Fehlfunktionen durch den Einsatz einer Grafikkarte oder Erweiterungskarte mit einem einzigen 8-poligen PCIe-Anschluss ab, die die Standardleistungsaufnahme von insgesamt 225 W übersteigt (150 W vom 8-poligen PCIe-Anschluss + 75 W vom PCIe-Motherboard-Steckplatz). Ebenso wird die Verwendung einer Grafikkarte oder Erweiterungskarte mit zwei 8-poligen PCIe-Anschlüssen, die eine Leistungsaufnahme von insgesamt 375 W übersteigen (300 W von den beiden 8-poligen PCIe-Anschlüssen + 75 W vom PCIe-Motherboard-Steckplatz) nicht durch die Garantie abgedeckt.

Der maximale Nennstrom von Peripherie- (Molex) oder SATA-Anschluss beträgt 5 A, was 60 W (+12 V x 5 A) oder 25 W (+5 V x 5 A) entspricht. Bitte achten Sie darauf, dass verbundene Geräte unter diesen Grenzwerten arbeiten. Die Garantie von SilverStone deckt keine Schäden oder Fehlfunktionen aufgrund einer Nutzung ab, die diese Anschlüsse und ihre zugehörigen Kabel übersteigt.

Der maximale Nennstrom des 24-poligen Motherboard-Anschlusses für seine dualen +12-V-Metallkontakte beträgt jeweils 5 A, was insgesamt 120 W (+12 V x 5 A x 2) ergibt. Bitte stellen Sie sicher, dass mit dem Motherboard verbundene +12-V-Geräte unter diesen Grenzwerten arbeiten. SilverStones Garantie deckt keine Schäden oder Fehlfunktionen aufgrund einer Nutzung jenseits der Angaben dieser Anschlüsse und ihrer zugehörigen Kabel ab.

FR**Définition de l'utilisation excessive du connecteur d'alimentation électrique**

Le courant nominal maximum d'un câble et d'un connecteur PCIe 8 broches unique est de 12,5 A, ce qui correspond à 150 W (+12 V x 12,5 A). La garantie de SilverStone ne couvre donc pas les dommages ou les dysfonctionnements résultant de l'utilisation d'une carte graphique ou d'une carte d'extension avec un connecteur PCIe 8 broches unique qui dépasse une consommation énergétique totale de 225 W standard (150 W provenant du connecteur PCIe 8 broches + 75 W provenant de l'emplacement de la carte mère PCIe). De même, une carte graphique ou une carte d'extension avec deux connecteurs PCIe 8 broches qui dépasse une consommation énergétique totale de 375 W (300 W provenant des deux connecteurs PCIe 8 broches + 75 W provenant de l'emplacement de la carte mère PCIe) ne sera également pas couverte dans le cadre de la garantie.

Le courant nominal maximum d'un périphérique (Molex) ou d'un connecteur SATA est de 5 A, ce qui correspond à 60 W (+12 V x 5 A) ou 25 W (+5 V x 5 A). Veuillez vous assurer que les appareils connectés fonctionnent dans ces limites. La garantie de SilverStone ne couvre pas les dommages ou les dysfonctionnements résultant d'utilisations dépassant ces connecteurs et leurs câbles associés.

Le courant nominal maximal des connecteurs 24 broches de la carte mère pour ses doubles broches métalliques +12 V est de 5 A chacun, ce qui représente au total 120 W (+12 V x 5 A x 2). Veuillez vous assurer que les dispositifs de tension +12 V connectés à la carte mère fonctionnent dans ces limites. La garantie de SilverStone ne couvre pas les dommages ou les dysfonctionnements résultant d'utilisations dépassant la capacité de ces connecteurs et de leurs câbles associés.

IT**Definizione di uso eccessivo del connettore di alimentazione**

La corrente massima di un singolo cavo PCIe a 8 pin e del connettore è 12,5 A, corrispondente a 150 W (+12 V x 12,5 A). Pertanto, la garanzia di SilverStone non copre danni o malfunzionamenti derivanti dall'utilizzo di una scheda grafica o una scheda di espansione con un singolo connettore PCIe a 8 pin che supera l'assorbimento totale di 225 W (150 W da connettore PCIe a 8 pin + 75 W da slot PCIe). Analogamente, la garanzia non copre anche una scheda grafica o una scheda di espansione con doppi connettori PCIe a 8 pin che superano l'assorbimento totale di 375 W (300 W da doppi connettori PCIe a 8 pin + 75 W dalla scheda madre PCIe).

La corrente massima del connettore periferico (molex) o SATA è 5 A, corrispondente a 60 W (+12 V x 5 A) o 25 W (+5 V x 5 A). Assicurarsi che i dispositivi collegati funzionino entro questi limiti. La garanzia di SilverStone non copre danni o malfunzionamenti derivanti da uso eccessivo di questi connettori e dei relativi cavi.

La corrente massima del connettore a 24 pin per scheda madre per i suoi due pin di metallo a +12 V è di 5 A ciascuno, per un totale di 120 W (+12 V x 5 A x 2). Assicurarsi che i dispositivi a +12 V collegati alla scheda madre funzionino con questi limiti. La garanzia di SilverStone non copre danni o malfunzionamenti derivanti da uso eccessivo di questi connettori e dei relativi cavi.

ES**Definición de uso excesivo del conector de la Fuente de alimentación**

La corriente máxima de un solo cable PCIe de 8 pines es 12,5A, lo que son 150W (+12V x 12,5A). Por tanto, la garantía de SilverStone no cubrirá daños o fallos provocados por el uso de una tarjeta gráfica o de expansión con un único conector PCIe de 8 pines que exceda el total estándar de 225W (150W del conector PCIe de 8 pines + 75W del zócalo PCIe de la placa base). De igual modo, una tarjeta gráfica o de expansión con conectores duales PCIe de 8 pines que superen 375W de potencia (300W de los dos conectores PCIe de 8 pines + 75W del zócalo de la placa base) tampoco será cubierta por la garantía.

La corriente máxima del conector de periféricos (molex) o SATA es 5A, que son 60W (+12V x 5A) o 25W (+5V x 5A). Por favor, asegúrese de que los dispositivos conectados funcionan dentro de estos límites. La garantía de SilverStone no cubrirá daños o fallos a resultados de un uso excesivo de estos conectores y sus cables asociados.

La corriente máxima del conector de 24 pines de la placa base para sus pines de metal duales de +12V es de 5A cada uno, para un total de 120W (+12V x 5A x 2). Por favor, asegúrese de que los dispositivos de +12V conectados a la placa base funcionen dentro de estos límites. La garantía de SilverStone no cubrirá daños o averías a resultados de un uso excesivo para estos conectores y sus cables asociados.

RU**Определение чрезмерной нагрузки на коннектор блока питания**

Один кабель и коннектор PCIe 8pin поддерживает ток 12,5А, что равно 150Вт (+12В x 12,5А). Таким образом, гарантийные обязательства SilverStone не будут действовать если вы используете видеокарту или другую карту расширения с одним коннектором PCIe 8pin, которые превышают стандартную общую потребляемую мощность 225Вт (150Вт через коннектор PCIe 8pin + 75Вт через slot PCIe материнской платы). Аналогично, видеокарта или другая карта расширения с двумя коннекторами PCIe 8pin, которые превышают общую потребляемую мощность 375Вт (300Вт через коннектор PCIe 8pin + 75Вт через slot PCIe материнской платы), также не будут покрываться гарантией.

Максимальный номинальный ток периферийного (molex) или SATA разъёма составляет 5А, что равно 60Вт (+12В x 5А) или 25Вт (+5В x 5А). Пожалуйста, убедитесь, что подключенные устройства работают в этих пределах. Гарантия SilverStone не будет распространяться на неисправности, возникающие в результате использования этих коннекторов или подключаемых к ним кабелей.

Максимальный номинальный ток 24pin коннектора материнской платы для его двойных металлических контактов +12В составляет 5А на каждый, что равно 120Вт (+12В x 5А x 2). Пожалуйста, убедитесь, что устройства, подключаемые к линии +12В, работают в этих пределах. Гарантия SilverStone не будет распространяться на неисправности, возникающие в результате использования этих коннекторов или подключаемых к ним кабелей.

KR**전원 공급 커넥터 과용 정의**

단일한 PCIe 8핀 케이블 및 커넥터의 최대 전류 정격은 12.5A로서 전력으로 환산하면 150W(+12V x 12.5A)입니다. SilverStone의 보증에서는 표준 225W의 총 소비 전력 (PCIe 8핀 커넥터의 150W와 PCIe 메인보드 슬롯의 75W의 합)을 초과하는 단일 PCIe 8핀 커넥터 탑재 그래픽 카드나 확장 카드를 사용하여 발생하는 손상 또는 오작동을 보상이하지 않습니다. 이와 마찬가지로 375W의 총 소비 전력 (PCIe 8핀 커넥터 2개의 300W와 PCIe 메인보드 슬롯의 75W의 합)을 초과하는 듀얼 PCIe 8핀 커넥터 탑재 그래픽 카드나 확장 카드를 사용해도 보증에서 보상해주지 않습니다.

주변장치(molex) 또는 SATA 커넥터의 최대 전류 정격은 5A로서 전력으로 환산하면 60W(+12V x 5A) 또는 25W(+5V x 5A)입니다. 연결된 장치들은 이러한 제한 하에서만 작동시켜야 합니다. SilverStone의 보증에서는 이러한 커넥터 및 이와 연결되는 케이블의 정격을 초과하여 사용함으로써 발생하는 손상이나 오작동을 보상이하지 않습니다.

듀얼 +12V 금속 핀에 사용되는 24핀 메인보드 커넥터의 정격 전류는 5A이며, 각각 합계가 120W (+12V x 5A x 2)입니다. 메인보드에 연결된 +12V 장치가 해당 한계 미만으로 작동되도록 하십시오. SilverStone은 이 커넥터나 관련 케이블의 한계를 초과해서 사용함으로써 발생하는 손상이나 고장에 대해서 보장하지 않습니다.

JP**電力供給コネクタの使用限度超過に関する説明**

単一のPCIe 8ピンケーブルおよびコネクタの最大定格電流は12.5Aで150W (+12V x 12.5A)となります。それで定格225W合計電力消費 (PCIe 8ピンコネクタからの150W + PCIeマザーボードスロットからの75W)を超える。単一PCIe 8ピンコネクタ装備のグラフィックスカードまたは拡張カード使用によって生じた損傷や故障の場合、SilverStoneの製品保証は適用外となります。同様に、375W合計電力消費(2基のPCIe 8ピンコネクタからの300W + PCIeマザーボードスロットからの75W)を超える。デュアルPCIe 8ピンコネクタ装備のグラフィックスカードまたは拡張カード使用によって生じた損傷や故障の場合も、製品保証適用外となります。

周辺用 (molex) またはSATAコネクタの最大定格電流は5Aで、60W (+12V x 5A) または25W (+5V x 5A) となります。接続された装置がこれら限度以内で動作することを確認してください。これらコネクタおよび関連ケーブルの定格を超える使用法で生じた損傷や故障については、SilverStone製品保証対象外となりますのでご注意ください。

24ピンマザーボードコネクタのデュアル+12V金属製ピンに対する最大定格電流はそれぞれ5Aなので合計は120W (+12V x 5A x 2) となります。接続される+12V入力デバイスが、これら上限以内で動作することをご確認ください。これらコネクタおよび関連ケーブルでの限界を超えた使用で生じた損傷または故障は、SilverStoneによる製品保証対象外となります。

CN**电源供应器接头过度使用定义**

单条PCIe 8pin电源线与接头的最大额定电流为12.5A，瓦特数150W (+12V x 12.5A)。因此，银欣的电源保固不包括用于单条PCIe 8pin接头之显卡/扩充卡，在超过标准225W总功耗范围所造成的损坏或故障 (150W 的PCIe 8pin接头+ 75W的主板PCIe插槽)。以此类推，若具备双PCIe 8pin接头的显卡/扩充卡，负载一旦超过375W总功耗，视同不属保固范围内 (300W来自两个PCIe 8pin接头 + 75W的主板PCIe插槽)。

大4pin (molex) 或SATA接头的最大额定电流为5A，即60W (+12V x 5A) 或25W (+5V x 5A)。请确保连接的设备皆低于此限制下运行。银欣不保固超出电源供应器接头及其相关线材之使用负载上限所造成的损坏或故障。

24pin主板接头的双+12V金属引脚最大额定电流为5A，即120W (+12V x 5A x 2)。请确保连接的+12V设备皆低于此限制下运行。银欣不保固超出电源供应器接头及其相关线材之使用负载上限所造成的损坏或故障。

TW**電源供應器接頭過度使用定義**

單條PCIe 8pin電源線與接頭的最大額定電流為12.5A，瓦特數150W (+12V x 12.5A)。因此，銀欣的電源保固不包括用於單條PCIe 8pin接頭之顯卡/擴充卡，在超過標準225W總功耗範圍所造成的損壞或故障 (150W 的PCIe 8pin接頭+ 75W的主機板PCIe插槽)。以此類推，若具備雙PCIe 8pin接頭的顯卡/擴充卡，負載一旦超過375W總功耗，視同不屬保固範圍內 (300W來自兩個PCIe 8pin接頭 + 75W的主機板PCIe插槽)。

大4pin (molex) 或SATA接頭的最大額定電流為5A，即60W (+12V x 5A) 或25W (+5V x 5A)。請確保連接的設備皆低於此限制下運行。銀欣不保固超出電源供應器接頭及其相關線材之使用負載上限所造成的損壞或故障。

24pin主機板接頭的雙+12V金屬針腳最大額定電流為5A，即120W (+12V x 5A x 2)。請確保連接的+12V設備皆低於此限制下運行。銀欣不保固超出電源供應器接頭及其相關線材之使用負載上限所造成的損壞或故障。

TH**ขีดจำกัดการรองรับการใช้งานของหัวต่อจากพาวเวอร์ซัพพลาย**

สำหรับหัวเชื่อมต่อแต่ละสายไฟเลี้ยง PCIe 8 พินสามารถรองรับกระแสไฟสูงสุด 12.5 แอมป์หรือหมายถึง 150 วัตต์ (+12V x 12.5A) ดังนั้นการรับประกันจากทาง SilverStone จะไม่ครอบคลุมถึงความเสี่ยงหรือความผิดพลาดที่เกิดกับชิ้นที่กราฟิการ์ดรวมตัวตามสายจากที่ใช้งานหัวเชื่อมต่อ PCIe 8 พิน ซึ่งนับมีการไหลพลังงานรวมกันสัมพันธ์กับมาตรฐานที่กำหนดคือ 225 วัตต์ (150 วัตต์ จาก PCIe 8 พิน + 75 วัตต์ จากสลิต PCIe บนเมนบอร์ด) ับรวมถึงกราฟิการ์ดหรือรวมตัวตามสายหัวต่อไฟเลี้ยง PCIe 8 พินจำนวน 2 ชุดซึ่งมีการไหลพลังงานทั้งสิ้น 375 วัตต์ (300 วัตต์ จากหัว PCIe 8 พิน 2 ชุด + 75 วัตต์ จากสลิต PCIe บนเมนบอร์ด) ซึ่งไม่ครอบคลุมเช่นกัน

ภายใต้การรับประกัน หัวเชื่อมต่อ Peripheral หรือ Molex 4 พินและ SATA นั้นสามารถรองรับกระแสไฟสูงสุด 5 แอมป์หรือหมายถึง 60 วัตต์ (+12V x 5A) หรือ (+5V x 5A)

กรุณาให้แน่ใจว่าอุปกรณ์ที่ใช้งานมีการไหลพลังงานไม่เกินกว่าขีดจำกัดที่รองรับ ดังนั้นการรับประกันจากทาง SilverStone จะไม่ครอบคลุมถึงความเสี่ยงหรือความผิดพลาดจากอุปกรณ์ที่เชื่อมต่อใช้งานจากตัวสายเชื่อมต่อซึ่งมีการไหลพลังงานเกินกว่าขีดจำกัด

กระแสไฟสูงสุดของหัวต่อบนเมนบอร์ด 24 พิน สำหรับพินละ: +12V คู่ต่อละนับมีค่า 5A ซึ่งรวมกันตามเป็น 120W (+12V x 5A x 2) ไม่ครอบคลุมส่วนที่นับมีค่าอุปกรณ์ต่อถึงพลังงาน +12V ที่เชื่อมต่อกับเมนบอร์ดสามารถทำงานภายใต้ขีดจำกัดเหล่านี้ได้ การรับประกันของ SilverStone ไม่ได้ครอบคลุมความเสี่ยง หรืออาการเสียหายที่นับเป็นผลจากการใช้เกินกว่าขีดต่อแต่ละสายแต่เป็นสิ่งที่ขึ้นอยู่กับผู้ใช้

1. 為了保護使用者及防火的目的，安裝此交換式電源供應器時，必須安裝於符合下列各項要求的外殼中，並且安裝妥善後，才可接上電源。
 - 1-1. 外殼材質須為防火外殼。外壳材质须为防火外壳。
 - 1-2. 外殼的上方及側邊之圓形開孔，最大內徑不可大於5mm。
 - 1-3. 外殼的上方及側邊之長條型開孔，對角線距離不可大於5mm；若寬度小於1mm，則長度不受限制。
 - 1-4. 外殼底部不可有開孔。外壳底部不可有开孔。

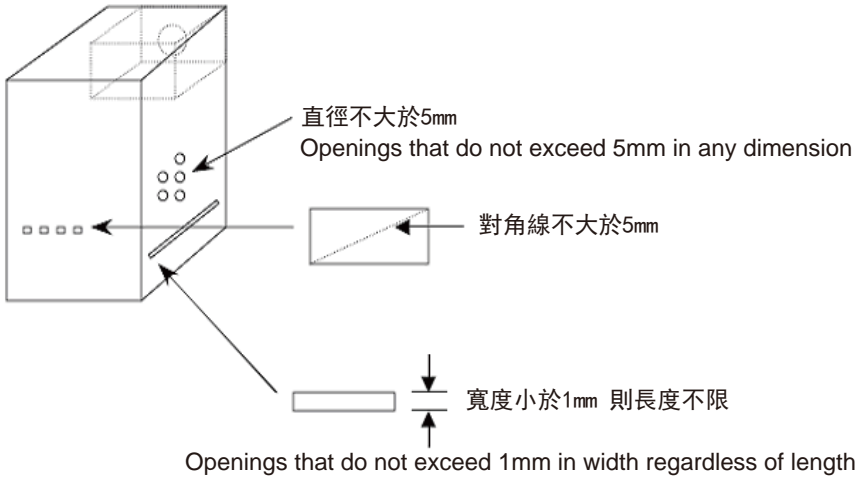

2. 本產品輸出含有危險能量，為避免操作時發生危險，須於裝入系統機殼並將所有設備安裝妥當後才可開啟電源。
3. 本產品之電源輸出非屬電力限制型電源，請連接使用具防火外殼之周邊，以避免火災危險發生。

BSMI ROHS 資訊

<http://www.silverstonetek.com/downloads/PSU/RSD.pdf>

开关电源供应器 有毒有害物质/元素及其化学含量表						
部件名称	铅 (Pb)	汞 (Hg)	镉 (Cd)	六价铬 (Cr(VI))	多溴联苯 (PBB)	多溴二苯醚 (PBDE)
外壳	○	○	○	○	○	○
接头	○	○	○	○	○	○
风扇	○	○	○	○	○	○
电子卡	○	○	○	○	○	○
线材	○	○	○	○	○	○
螺丝	○	○	○	○	○	○
包材	○	○	○	○	○	○

本表格依据SJ/T 11364的规定编制

○：表示该有毒有害物质在该部件所有均质材料中的含量均在GB/T 26572 规定的限量要求以下。

×：表示该有毒有害物质至少在该部件的某一均质材料中的含量超出GB/T 26572 规定的限量要求。



产品合格证

检验员: 杨01
生产日期: 见产品条码

This device complies with Part 15 of the FCC Rules.

Operation is subject to the following two conditions:

- (1) this device may not cause harmful interference, and
- (2) this device must accept any interference received, including interference that may cause undesired operation.

※付属の電源コードは当該製品専用です。他の機器に使用しないでください。

Please refer to SilverStone website for latest specifications updates.

SilverStone Technology Co., Ltd.

www.silverstonetek.com

support@silverstonetek.com

NO. G11240220
