

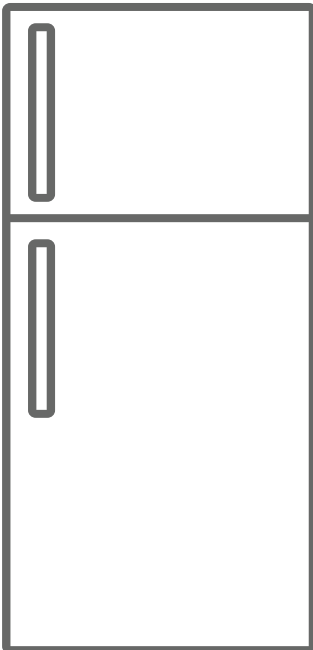

- EN User Manuel**  
Freezer - Fridge
- DE Bedienungsanleitung**  
Kühl-Gefrierkombination
- FR Manuel d'utilisation**  
Congélateur – Réfrigérateur
- IT Manuale per l'uso**  
Congelatore - Frigorifero
- NL Handleiding**  
Vriezer - Koelkast



FD76EN1HX



<b>EN</b>	<b>FIRE</b>	<b>Warning;</b> Risk of fire / flammable materials
<b>DE</b>	<b>BRANDGEFAHR</b>	<b>Warnung;</b> Brandgefahr / entflammbare Materialien
<b>FR</b>	<b>INCENDIE</b>	<b>Avertissement;</b> Risque d'incendie / matières inflammables
<b>IT</b>	<b>INCENDIO</b>	<b>Avvertenza;</b> Rischio di incendio / Materiali infiammabili
<b>NL</b>	<b>BRAND</b>	<b>Waarschuwing;</b> Gevaar voor brand / ontvlambare materialen

# Index

<b>BEFORE USING THE APPLIANCE .....</b>	<b>4</b>
General warnings .....	4
Old and out-of-order fridges .....	7
Safety warnings .....	7
Installing and operating your fridge freezer .....	8
Before using your fridge freezer .....	9
<b>THE VARIOUS FUNCTION AND POSSIBILITIES .....</b>	<b>9</b>
Information about new generation cooling technology .....	9
Display and Control Panel .....	10
Operating your Fridge Freezer .....	10
Freezer Temperature Settings .....	10
Cooler Temperature Settings .....	10
Super Freeze Mode .....	11
Warnings about Temperature Adjustments .....	11
Accessories .....	12
Making ice cubes (Icematic) .....	12
Chiller shelf .....	13
Fresh dial .....	13
Natural ion tech / Ionisier .....	14
<b>ARRANGING FOOD IN THE APPLIANCE .....</b>	<b>15</b>
Refrigerator compartment .....	15
Freezer compartment .....	16
<b>CLEANING AND MAINTENANCE .....</b>	<b>19</b>
Replacing LED lighting .....	19
<b>TRANSPORTATION AND CHANGING OF INSTALLATION POSITION .....</b>	<b>20</b>
Repositioning the Door .....	20
<b>BEFORE CALLING YOUR AFTER SALES SERVICE.....</b>	<b>20</b>
Tips for saving energy .....	24
<b>THE PARTS OF THE APPLIANCE AND THE COMPARTMENTS .....</b>	<b>25</b>
Dimensions .....	26
<b>TECHNICAL DATA .....</b>	<b>27</b>
<b>INFORMATION FOR TEST INSTITUTES.....</b>	<b>27</b>
<b>CUSTOMER CARE AND SERVICE .....</b>	<b>27</b>

### General warnings

This appliance is not intended to be used as a built-in appliance.

 **WARNING:** Keep ventilation openings in the appliance enclosure or in the built-in structure clear of obstruction.

 **WARNING:** Do not use mechanical devices or other means, other than those recommended by the manufacturer, to accelerate the defrosting process.

 **WARNING:** Do not use electrical appliances inside the food storage compartments of the appliance, unless they are of the type recommended by the manufacturer.

 **WARNING:** Do not damage the refrigerant circuit.

 **WARNING:** To avoid a hazard due to the instability of the appliance, it must be fixed in accordance with the instructions.

 **WARNING:** When positioning the appliance, ensure the supply cord is not trapped or damaged.

 **WARNING:** Do not locate multiple portable socket-outlets or portable power supplies at the rear of the appliance.

 If your appliance uses R600a as a refrigerant (you can find this information on the label on the cooler) be careful during shipment and installation to prevent your appliance's cooler elements from being damaged. Although R600a is an environmental friendly and natural gas, it is explosive. If the cooler elements have been damaged and you suspect a leak, move the Fridge Freezer away from any heat sources or open flame and ventilate the room the Fridge Freezer is in for a few minutes.

- While carrying and positioning the fridge, do not damage the cooler gas circuit.
- Do not store explosive substances such as aerosol cans with a flammable propellant in this appliance.

- This appliance is intended to be used in household and similar environments such as:
  - staff kitchen areas in shops, offices and other working environments
  - farm houses and by clients in hotels, motels and other residential type environments
  - bed and breakfast type environments
  - catering and similar non-retail applications
- If the socket does not match the refrigerator plug, it must be replaced by the manufacturer, its service agent or similar qualified persons in order to avoid a hazard.
- This appliance can be used by children aged from 8 years and above and persons with reduced physical, sensory or mental capabilities or lack of experience and knowledge if they have been given supervision or instruction concerning use of the appliance in a safe way and understand the hazards involved. Children shall not play with the appliance. Cleaning and user maintenance shall not be made by children without supervision.
- Children aged from 3 to 8 years are allowed to load and unload refrigerating appliances. Children are not expected to perform cleaning or user maintenance of the appliance, very young children (0-3 years old) are not expected to use appliances, young children (3-8 years old) are not expected to use appliances safely unless continuous supervision is given, older children (8-14 years old) and vulnerable people can use appliances safely after they have been given appropriate supervision or instruction concerning use of the appliance. Very vulnerable people are not expected to use appliances safely unless continuous supervision is given.
- A specially grounded plug has been connected to the power cable of your refrigerator. This plug should be used with a specially grounded socket of 16 amperes. If there is no such

socket in your house, please have it installed by a qualified electrician.

- If the supply cord is damaged it must be replaced by the manufacturer, its service agent or similar qualified persons in order to avoid a hazard.
- This appliance is not intended for use at altitudes exceeding 2000 m.

**To avoid contamination of food, please respect the following instructions:**

- Opening the door for long periods can cause a significant increase of the temperature in the compartments of the appliance.
- Clean regularly surfaces that can come in contact with food and accessible drainage systems.
- Store raw meat and fish in suitable containers in the refrigerator, so that it is not in contact with or drip onto other food.
- Two-star frozen-food compartments are suitable for storing pre-frozen food, storing or making ice cream and making ice cubes.
- One-, two- and three-star compartments are not suitable for the freezing of fresh food.
- If the refrigerating appliance is left empty for long periods, switch off, defrost, clean, dry, and leave the door open to prevent mould developing within the appliance.

## Old and out-of-order fridges

- If your old fridge has a lock, break or remove the lock before discarding it. Children may get trapped inside it and may cause an accident.
- Old fridges and freezers contain isolation material and refrigerant with CFC. Therefore, take care not to harm the environment when you discard your old fridge.

## Disposal of your old appliance

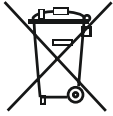

The symbol on the product or on its packaging indicates that this product may not be treated as household waste. Instead it shall be handed over to the applicable collection point for the recycling of electrical and electronic equipment. By ensuring this product is disposed of correctly, you will help prevent potential negative consequences for the environment and human health, which could otherwise be caused by inappropriate waste handling of this product. For more detailed information about recycling of this product, please contact your local city office, your household waste disposal service or the shop where you purchased the product.

## Notes:

- Please read the instruction manual carefully before installing and using your appliance.  
**We are not responsible for any damage caused due to misuse.**
- Follow all instructions on your appliance and instruction manual and keep this manual in a safe place to resolve any problems that may occur in the future.
- This appliance is produced to be used at houses and it can only be used in a house for the specified purposes. It is not suitable for commercial or common use. Such use will cause the guarantee of the appliance to be cancelled and our company will not be responsible for any losses which are incurred.
- This appliance is produced to be used in houses and it is only suitable for cooling / storing foods. It is not suitable for commercial or common use and/or for storing substances other than food. Our company is not responsible for any losses which are incurred in the contrary case.

## Safety warnings

- Do not connect your fridge freezer to the main electricity supply using an extension lead.
- Do not plug in damaged, torn or old plugs.
- Do not pull, bend or damage the cord.

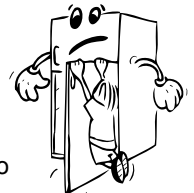

- This appliance is designed for use by adults, do not allow children to play with the appliance or let them hang off the door.
- Never touch the power cord/plug with wet hands as this could cause a short circuit or electric shock.
- Do not place glass bottles or beverage cans in the ice-making compartment as they can burst as the contents freeze.
- Do not place explosive or flammable material in your fridge. Place drinks with high alcohol content vertically in the fridge compartment and make sure that their tops are tightly closed.



- When removing ice from the ice-making compartment, do not touch it. Ice may cause frost burns and/or cuts.
- Do not touch frozen goods with wet hands. Do not eat ice-cream or ice cubes immediately after you have taken them out of the ice-making compartment.
- Do not re-freeze frozen goods after they have melted. This may cause health issues such as food poisoning.
- Do not cover the body or top of fridge with lace. This affects the performance of your fridge.
- Secure any accessories in the fridge during transportation to prevent damage to the accessories.
- Do not use plug adapter.



## Installing and operating your fridge freezer

Before starting to use your fridge freezer, you should pay attention to the following points:

- The operating voltage for your fridge freezer is 220-240 V at 50Hz.
- We do not accept responsibility for any damages that occur due to ungrounded usage.
- Place your fridge freezer where it will not be exposed to direct sunlight.
- Your appliance should be at least 50 cm away from stoves, gas ovens and heater cores, and at least 5 cm away from electrical ovens.
- Your fridge freezer should never be used outdoors or exposed to rain.
- When your fridge freezer is placed next to a deep freezer, there should be at least 2 cm between them to prevent humidity forming on the outer surface.
- Do not place anything on your fridge freezer, and install your fridge freezer in a suitable place so that at least 15 cm of free space is available above it.
- Do not place heavy items on the appliance.
- Use the adjustable levelling feet to make sure your appliance is level and stable. You can adjust the levelling feet by turning them in either direction. This should be done before placing food in the fridge freezer.
- Before using your fridge freezer, wipe all parts with a solution of warm water and a teaspoon of sodium bicarbonate, then rinse with clean water and dry. Place all parts in the fridge after cleaning.
- Refrigerator should be placed against a wall with a free distance not exceeding 75 mm.



### If your refrigerator has a fan condenser:

The condenser of your fridge is placed at the bottom of cabinet. As a result of that, assemble the spacer by fixing it to holes on the cover bottom panel and turn 90° that's shown below figure for arranging the distance between the refrigerator and the back wall at where you place the fridge. You can move the fridge towards the back wall until that point.

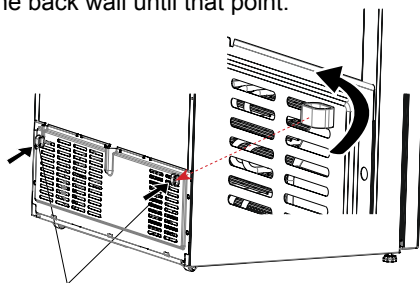

Plastic for distance setting



## Before using your fridge freezer

- When using your fridge freezer for the first time, or after transportation, keep it in an upright position for at least 3 hours before plugging into the mains. This allows efficient operation and prevents damage to the compressor.
- Your fridge freezer may have a smell when it is operated for the first time. This is normal and the smell will fade away when your fridge freezer starts to cool.

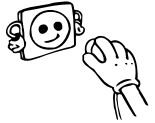

### Internal lighting



**WARNING!**

Risk of electric shock.

- Concerning the lamp(s) inside this product and spare part lamps sold separately: These lamps are intended to withstand extreme physical conditions in household appliances, such as temperature, vibration, humidity, or are intended to signal information about the operational status of the appliance. They are not intended to be used in other applications and are not suitable for household room illumination.

### General notes:

**Fresh Food Compartment (Fridge):** Most efficient use of energy is ensured in the configuration with the drawers in the bottom part of the appliance, and shelves evenly distributed, position of door bins does not affect energy consumption.

**Freezer Compartment (Freezer):** Most Efficient use of energy is ensured in the configuration with the drawers and bins are on stock position.

## CHAPTER - 2 THE VARIOUS FUNCTION AND POSSIBILITIES

### Information about new generation cooling technology

Fridges with new generation cooling technology have a different working system than static fridges. Other fridges may experience ice build up in the freezer compartment due to door openings and humidity in the food. In such fridges regular defrosting is required; the fridge has to be periodically turned off, the frozen food moved to a suitable container and the ice which has formed in the freezer compartment removed.

In fridges with new generation cooling technology, dry cold air is pumped evenly into the fridge and freezer compartments using a fan. The cold air cools your food evenly and uniformly, preventing humidity and ice build up.

In the refrigerator compartment, air blown by the fan located at the top of refrigerator compartment is cooled while passing through the gap behind the air duct. At the same time, the air is blown out through the holes in the air duct evenly spreading cool air throughout the refrigerator compartment.

As there is no air passage between the freezer and refrigerator compartments there will be no odor mixing.

As a result of this, your fridge with new generation cooling technology gives you ease of use as well as huge volume and aesthetic appearance.

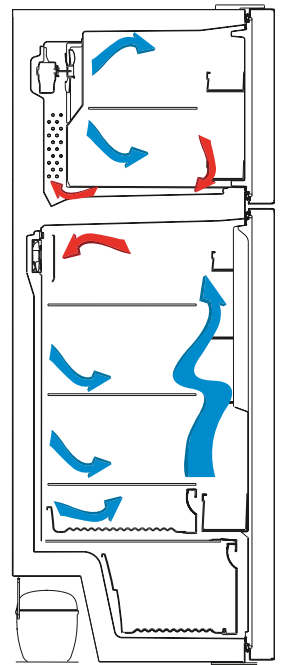

## Display and Control Panel

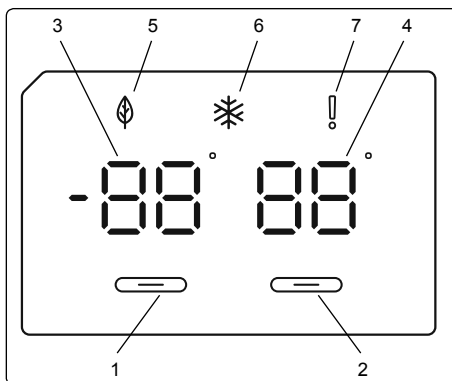

### Using the Control Panel

1. Enables the setting of the freezer.
2. Enables the setting of the cooler.
3. Freezer set value screen.
4. Cooler set value screen.
5. Economy mode symbol.
6. Super freeze symbol.
7. Alarm symbol.

### Operating your Fridge Freezer

Once you have plugged in the product, all symbols will be displayed for 2 seconds and the initial values will be shown as  $-18^{\circ}\text{C}$  on the freezer adjustment indicator, and  $+4^{\circ}\text{C}$  on the fridge adjustment indicator.

### Freezer Temperature Settings

- The initial temperature value for the freezer setting indicator is  $-18^{\circ}\text{C}$ .
- Press the freezer set button once.

When you first press the button, the previous value will blink on the screen.

- Whenever you press the same button, a lower temperature will be set ( $-16^{\circ}\text{C}$ ,  $-18^{\circ}\text{C}$ ,  $-20^{\circ}\text{C}$ ,  $-22^{\circ}\text{C}$  or  $-24^{\circ}\text{C}$ ).
- If you continue to press the button, it will restart from  $-16^{\circ}\text{C}$ .

**NOTE:** Eco mode gets activated automatically when the temperature of the freezer compartment is set to  $-18^{\circ}\text{C}$ .

### Cooler Temperature Settings

- The initial temperature value for the cooler setting indicator is  $+4^{\circ}\text{C}$ .
- Press the cooler button once.
- Whenever you press the button, a lower temperature will be set ( $+8^{\circ}\text{C}$ ,  $+6^{\circ}\text{C}$ ,  $+5^{\circ}\text{C}$ ,  $+4^{\circ}\text{C}$ , or  $+2^{\circ}\text{C}$ ).
- If you continue to press the button, it will restart from  $+8^{\circ}\text{C}$ .



## Super Freeze Mode

### Purpose

- To freeze a large quantity of food that cannot fit on the fast freeze shelf.
- To freeze prepared foods.
- To freeze fresh food quickly to retain freshness.

### How to use

To enable the super freeze mode, press and hold the freezer temperature setting button for 3 seconds. Once the super freeze mode has been set, the super freeze symbol on the indicator will be lit and the machine will beep to confirm the mode has been switched on.



### During Super Freeze Mode:

- The temperature of the Cooler may be adjusted. In this case, Super Freeze mode will continue.
- Economy mode cannot be selected.
- Super Freeze mode can be cancelled in the same way it is selected.

### Notes:

- The maximum amount of fresh food (in kilograms) that can be frozen within 24 hours is shown on the appliance label.
- For optimal appliance performance in maximum freezer capacity, activate super freeze mode 3 hours before you put fresh food into the freezer.



Super freeze mode will automatically cancel after 24 hours, depending on the environmental temperature or when the freezer sensor reaches a sufficiently low temperature.

## Recommended Settings for the Freezer and Cooler Compartment Temperature

Freezer Compartment	Cooler Compartment	Remarks
-18 °C	4 °C	For regular use and best performance.
-20 °C, -22 °C or -24 °C	4 °C	Recommended when environmental temperature exceeds 30 °C.
Super Freeze mode	4 °C	Must be used when you wish to freeze food in a short period of time.
-18 °C, -20 °C, -22 °C or -24 °C	2 °C	These temperature settings must be used when the environmental temperature is high or if you think the refrigerator compartment is not cool enough because the door is being opened frequently.

## Door Open Alarm Function

If the refrigerator door is opened more than 2 minutes, appliance sounds 'beep beep'.

## Warnings about Temperature Adjustments

- Temperature adjustments should be made according to the frequency of door openings and the quantity of food kept inside the fridge.
- This fridge is designed to work in all ambient temperature. In the ambient temperatures colder than -5 °C, preserving food in the refrigerator compartment isn't suggested because the foods that you put into refrigerator compartment, will have a temperature

close to ambient temperature. Consequently, they will freeze. You can keep your foods until  $-5\text{ }^{\circ}\text{C}$  in refrigerator compartments. With the aid of special algorithm that is designed by engineers, foods can be preserved in the freezer compartment, colder than  $-5\text{ }^{\circ}\text{C}$  ambient temperature.

- Your fridge should be operated up to 24 hours according to the ambient temperature without interruption after being plugged in to be completely cooled. Do not open doors of your fridge frequently and do not place much food inside it in this period.
- If the unit is switched off or unplugged, you must allow at least 5 minutes before restarting or re-plugged the unit in order not to damage the compressor.
- Your fridge is designed to operate in the ambient temperature intervals stated in the standards, according to the climate class stated in the information label. We do not recommend operating your fridge out of stated temperatures value limits in terms of cooling effectiveness.
- This appliance is designed for use at an ambient temperature within the  $10^{\circ}\text{C} - 43^{\circ}\text{C}$  range.

#### Climate class and meaning:

**T (tropical):** This refrigerating appliance is intended to be used at ambient temperatures ranging from  $16\text{ }^{\circ}\text{C}$  to  $43\text{ }^{\circ}\text{C}$ .

**ST (subtropical):** This refrigerating appliance is intended to be used at ambient temperatures ranging from  $16\text{ }^{\circ}\text{C}$  to  $38\text{ }^{\circ}\text{C}$ .

**N (temperate):** This refrigerating appliance is intended to be used at ambient temperatures ranging from  $16\text{ }^{\circ}\text{C}$  to  $32\text{ }^{\circ}\text{C}$ .

**SN (extended temperate):** This refrigerating appliance is intended to be used at ambient temperatures ranging from  $10\text{ }^{\circ}\text{C}$  to  $32\text{ }^{\circ}\text{C}$ .

### Accessories (In some models)

#### Making ice cubes (Icematic)

- Take out the ice making tray
- Fill the water to the line.
- Place the ice making tray in its original position
- When ice cubes are formed, twist the lever to drop ice cubes into the icebox.

#### Note:

- Do not fill the icebox with water to make ice. This may damage it.
- The movement of the ice maker may be difficult while the refrigerator is running. In such a case it should be cleaned by removing the glass shelves.

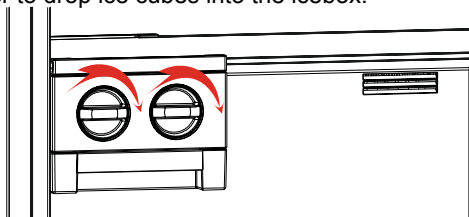

#### Removing the Ice maker (In some models)

- Remove the freezer glass shelves
- Remove the icemaker by pulling left or right on the shelf.

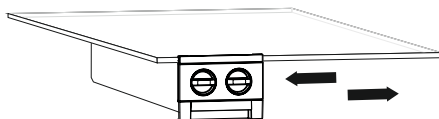

You can remove the icemaker to increase the available volume in the freezer compartment.

### Ice tray

- Fill the ice tray with water and place in the freezer compartment.
- After the water has completely turned into ice, you can twist the tray as shown below to remove the ice cubes.

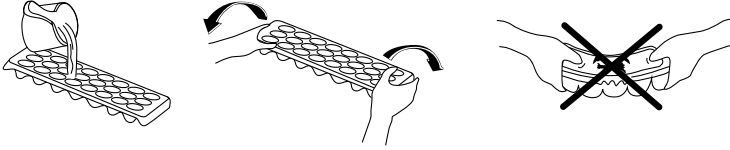

### Chiller shelf *(In some models)*

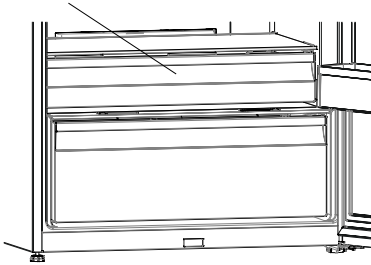

Keeping food in the Chiller compartment instead of the freezer or refrigerator compartment allows food retain freshness and flavour longer, while preserving its fresh appearance. When chiller tray becomes dirty, remove it and wash it with water.

(Water freezes at 0°C, but foods containing salt or sugar freeze at temperature lower than that)

Normally people use the chiller compartment for raw fish, lightly pickled, rice, etc...

**Do not put foods you want to freeze or ice trays in order to make ice.**

### Removing the Chiller shelf

- Pull the chiller shelf out toward you by sliding on rails.
- Pull the chiller shelf up from rail to remove.

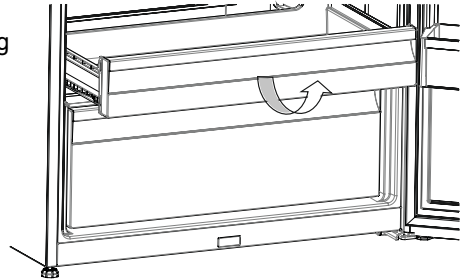

### Fresh dial *(In some models)*

When the humidity controller in the closed position, it allows fresh fruit and vegetables to be stored longer.

In case of the crisper is totally full, the fresh dial is located in front of crisper, should be opened. By means of this the air in the crisper and humidity rate will be controlled and endurance life will be increased.

If you see any condensation on glass shelf, humidity control should be taken into the open positions.

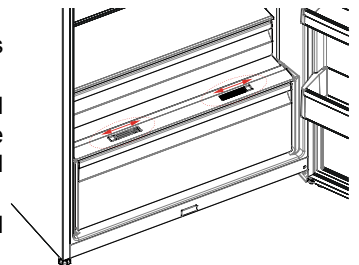

### Adjustable door shelf (In some models)

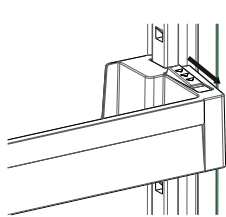

Fig.1

Six different height adjustments can be made to provide storage areas that you need by adjustable door shelf .

#### To change the position of adjustable door shelf;

Hold the bottom of the shelf and pull the buttons on the side of the door shelf direction of arrow (Fig.1).

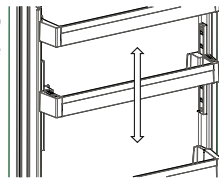

Fig.2

Position door shelf the height you need by moving up and down. After you get the position that you want the door shelf, release the buttons on the side of the door shelf (Fig.2) Before releasing the door shelf, move up down and make sure the door shelf is fixed.

**Note:** Before moving door shelf is loaded, you must hold the shelf by supporting the bottom. Otherwise, door shelf could fall off the rails due to the weight. So damage may occur on the door shelf or rails.

### Natural ion tech / Ionisier (In some models)

Natural Ion Tech spreads negative ions which neutralize particles of unpleasant smell and dust in the air.

By removing these particles from the air in the refrigerator, Natural Ion Tech improves air quality and eliminates odours.

- This feature is optional. It may not exist on your product.
- The location of your ioniser device may vary from product to product.

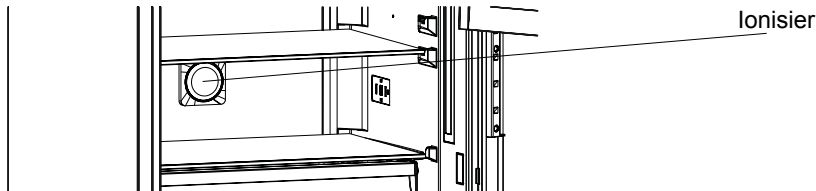

**Visual and text descriptions on the accessories section may vary according to the model of your appliance.**

## CHAPTER - 3 ARRANGING FOOD IN THE APPLIANCE

### Refrigerator compartment

- To reduce humidity and consequent increase of frost never place liquids in unsealed containers in the refrigerator.
- Never place warm food in the refrigerator. Warm food should be allowed to cool at room temperature and arranged to ensure adequate air circulation in the refrigerator compartment.
- Arrange meat and cleaned fish (wrapped in packages or sheets of plastic) and use them within 1-2 days.
- You can put the fruits and vegetables into the crisper without any packaging.

#### Important note:

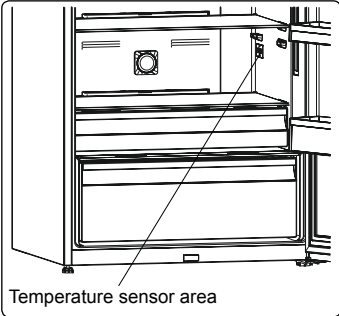
- Cover any cooked dishes when you put them in the fridge. Place them in the fridge when they are cool, otherwise temperature/humidity inside the fridge increases which causes the fridge to work harder. Covering food and beverages also preserves their flavour and aroma.
  - Potatoes, onion and garlic should not be kept in the fridge.
  - Make sure food does not touch the temperature sensor which is located in the refrigerator compartment. To keep an optimum temperature in the refrigerator compartment, make sure food doesn't make contact with the sensor.
- 
- The diagram shows a cross-section of a refrigerator compartment. A line points to a small circular sensor located on the upper part of the interior wall. Below the diagram, the text 'Temperature sensor area' is written.
- For normal working conditions, it will be sufficient to adjust the temperature setting of your refrigerator to +4 °C.
  - The temperature of the fridge compartment should be in the range of 0-8 °C, fresh foods below 0 °C are iced and rotted, bacterial load increases above 8 °C, and spoils.
  - Do not put hot food in the refrigerator immediately, wait for the temperature to pass outside. Hot foods increase the degree of your refrigerator and cause food poisoning and unnecessary spoiling of the food.
  - Meat, fish, etc. should be store in the chiller compartment of the food, and the vegetable compartment is preferred for vegetables. (if available)
  - To prevent cross contamination, meat products and fruit vegetables are not stored together.
  - Foods should be placed in the refrigerator in closed containers or covered to prevent moisture and odors.

The table below is a quick guide to show you the most efficient way to store the major food groups in your refrigerator compartment.

Food	Maximum storage time	How and where to store
Vegetables and fruits	1 week	Vegetable bin
Meat and fish	2 - 3 Days	Wrap in plastic foil, bags, or in a meat container and store on the glass shelf
Fresh cheese	3 - 4 Days	On the designated door shelf

Food	Maximum storage time	How and where to store
Butter and margarine	1 week	On the designated door shelf
Bottled products e.g. milk and yoghurt	Until the expiry date recommended by the producer	On the designated door shelf
Eggs	1 month	On the designated egg shelf
Cooked food		All shelves

## Freezer compartment

- The freezer compartment is used for freezing fresh food, for storing frozen foods for the period of time indicated on packaging and for making ice cubes.
- Do not put fresh and warm foods in the freezer door shelves to be frozen. Only use the door shelves for storing frozen foods.
- For optimum appliance performance to reach maximum freezing capacity, Set the refrigerator at 4 °C for 24 hours before placing fresh food into the freezer.
- After placing fresh food into the freezer, change the setting to 2 °C for 24 hours is generally sufficient. After 24 hours, you can reduce the setting if required.
- Do not put fresh and warm food next to frozen food as it can thaw the frozen food.
- Use the fast freezing shelf to freeze home cooking (and any other food which needs to be frozen quickly) more quickly because of the freezing shelf's greater freezing power.
- While freezing fresh foods (i.e. meat, fish and mincemeat) divide them in portions you will use in a single serving.
- While freezing fresh foods, the maximum amount of fresh food (in kg) that can be frozen in 24 hours is indicated on the appliance label.
- For optimum appliance performance to reach maximum freezing capacity, turn the thermostat knob to the coldest setting 24 hours before placing fresh food into the freezer.
- After placing fresh food into the freezer, having the thermostat knob set to the coldest setting for 24 hours is generally sufficient. After 24 hours, you can reduce the thermostat knob setting if required.
- Attention. To save energy, if you are only freezing small amounts of food, you do not need to set the thermostat knob to the coldest setting.
- For storing frozen foods, the instructions shown on frozen food packages should always be followed carefully. If no information is provided, food should not be stored for more than 3 months from the purchased date.
- When buying frozen food ensure that these have been frozen at suitable temperatures and that the packing is intact.
- Frozen food should be transported in appropriate containers to maintain the quality of the food and should be returned to the freezing surfaces of the unit in the shortest possible time.
- If a package of frozen food shows the sign of humidity and abnormal swelling it is probable that it has been previously stored at an unsuitable temperature and that the contents have deteriorated.
- The storage life of frozen foods depends on the room temperature, thermostat setting, how often the door is opened, the type of food and the length of time required to



transport the product from the shop to your home. Always follow the instructions printed on the packaging and never exceed the maximum storage life indicated.



***In some models:*** while loading the freezing compartment, do not load above the the loading lines otherwise the door may not close correctly. If the freezer compartment door does not close correctly, excess ice may form in the freezer compartment. To prevent the problem recurring, clear the ice and make sure that the door is fully closed.

Also, not closing the freezer and/or fridge compartment doors would increase your energy consumption.

Meat and fish	Preparation	Maximum storage time (months)
<b>Steak</b>	Wrap in foil	6 - 8
<b>Lamb meat</b>	Wrap in foil	6 - 8
<b>Veal roast</b>	Wrap in foil	6 - 8
<b>Veal cubes</b>	In small pieces	6 - 8
<b>Lamb cubes</b>	In pieces	4 - 8
<b>Minced meat</b>	In packaging without using spices	1 - 3
<b>Giblets (pieces)</b>	In pieces	1 - 3
<b>Bologna sausage/salami</b>	Should be kept packaged even if it has a membrane	
<b>Chicken and turkey</b>	Wrap in foil	4 - 6
<b>Goose and duck</b>	Wrap in foil	4 - 6
<b>Deer, rabbit, wild boar</b>	In 2.5 kg portions or as fillets	6 - 8
<b>Freshwater fish (Salmon, Carp, Crane, Catfish)</b>	After cleaning the bowels and scales of the fish, wash and dry it. If necessary, remove the tail and head.	2
<b>Lean fish (Bass, Turbot, Flounder)</b>		4
<b>Fatty fishes (Tuna, Mackerel, Bluefish, Anchovy)</b>		2 - 4
<b>Shellfish</b>	Clean and in a bag	4 - 6
<b>Caviar</b>	In its packaging, or in an aluminium or plastic container	2 - 3
<b>Snails</b>	In salty water, or in an aluminium or plastic container	3
 <b>NOTE:</b>	Thawed frozen meat should be cooked as fresh meat. If the meat is not cooked after defrosting, it must not be re-frozen.	

Vegetables and Fruits	Preparation	Maximum storage time (months)
<b>String beans and beans</b>	Wash, cut into small pieces and boil in water	10 - 13
<b>Beans</b>	Hull, wash and boil in water	12
<b>Cabbage</b>	Clean and boil in water	6 - 8
<b>Carrot</b>	Clean, cut into slices and boil in water	12
<b>Pepper</b>	Cut the stem, cut into two pieces, remove the core and boil in water	8 - 10
<b>Spinach</b>	Wash and boil in water	6 - 9
<b>Cauliflower</b>	Remove the leaves, cut the heart into pieces and leave it in water with a little lemon juice for a while	10 - 12
<b>Eggplant</b>	Cut into pieces of 2cm after washing	10 - 12
<b>Corn</b>	Clean and pack with its stem or as sweet corn	12
<b>Apple and pear</b>	Peel and slice	8 - 10
<b>Apricot and Peach</b>	Cut into two pieces and remove the stone	4 - 6
<b>Strawberry and Blackberry</b>	Wash and hull	8 - 12

Vegetables and Fruits	Preparation	Maximum storage time (months)
<b>Cooked fruits</b>	Add 10 % of sugar to the container	12
<b>Plum, cherry, sourberry</b>	Wash and hull the stems	8 - 12

	Maximum storage time (months)	Thawing time at room temperature (hours)	Thawing time in oven (minutes)
<b>Bread</b>	4 - 6	2 - 3	4-5 (220-225 °C)
<b>Biscuits</b>	3 - 6	1 - 1,5	5-8 (190-200 °C)
<b>Pastry</b>	1 - 3	2 - 3	5-10 (200-225 °C)
<b>Pie</b>	1 - 1,5	3 - 4	5-8 (190-200 °C)
<b>Phyllo dough</b>	2 - 3	1 - 1,5	5-8 (190-200 °C)
<b>Pizza</b>	2 - 3	2 - 4	15-20 (200 °C)

Dairy products	Preparation	Maximum storage time (months)	Storage conditions
<b>Packet (Homogenized) Milk</b>	In its own packet	2 - 3	Pure Milk – in its own packet
<b>Cheese - excluding white cheese</b>	In slices	6 - 8	Original packaging may be used for short-term storage. Keep wrapped in foil for longer periods.
<b>Butter, margarine</b>	In its packaging	6	

If the lower shelf in the freezer door is removed and food is allowed to block the air suction hole, this will reduce the effectiveness of the fridge.

Therefore, be careful while loading the freezer compartment and make sure not to cover the air suction hole.

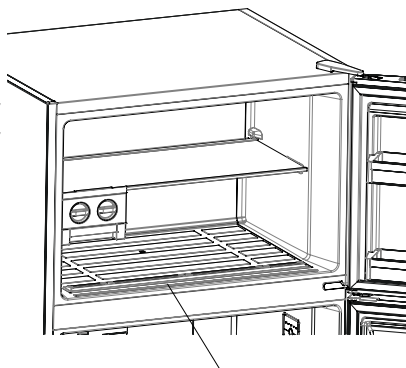

Air suction hole

## CHAPTER - 4 CLEANING AND MAINTENANCE

- Make sure to unplug the fridge before starting to clean it.

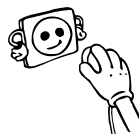

- Do not wash your fridge by pouring water.

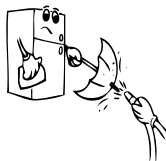

- You can wipe the inner and outer sides with a soft cloth or a sponge using warm and soapy water.

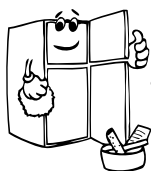
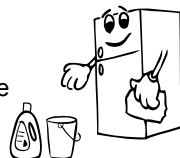

- Remove the parts individually and clean with soapy water. Do not wash in washing machine.



- Never use flammable, explosive or corrosive material like thinner, gas, acid for cleaning.

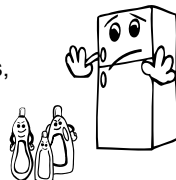

***Make sure that your fridge is unplugged while cleaning.***

### Replacing LED lighting

If your refrigerator has LED lighting contact the help desk as this should be changed by authorized personnel only.

**Note:** Numbers and location of led strips may be changed according to the model.

**!!! Some versions may be without freezer illumination.**

## CHAPTER - 5

# TRANSPORTATION AND CHANGING OF INSTALLATION POSITION

## Transportation and Changing of Installation Position

- Original package and foam may be kept for re-transportation (optionally).
- You should fasten your fridge with thick package, bands or strong cords and follow the instructions for transportation on the package for re-transportation.
- Remove movable parts (shelves, accessories, vegetable bins etc.) or fix them into the fridge against shocks using bands during re-positioning and transportation.

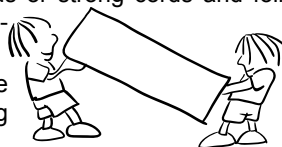

**Carry your fridge in the upright position.**

### Repositioning the Door

- It is not possible to change the opening direction of your fridge door, if the door handles on your fridge are installed from the front surface of the door.
- It is possible to change the opening direction of the door on models without any handles.
- If the door opening direction of your fridge may be changed, you should contact the nearest Authorized Service to have the opening direction changed.

## CHAPTER - 6

# BEFORE CALLING YOUR AFTER SALES SERVICE

### Check Warnings;

Your fridge warns you if the temperatures for cooler and freezer are in improper levels or when a problem occurs in the appliance. Warning codes are displayed in the Freezer and Cooler Indicators.

ERROR TYPE	MEANING	WHY	WHAT TO DO
E01	Sensor warning		Call Service for assistance as soon as possible.
E02	Sensor warning		Call Service for assistance as soon as possible.
E03	Sensor warning		Call Service for assistance as soon as possible.
E06	Sensor warning		Call Service for assistance as soon as possible.
E07	Sensor warning		Call Service for assistance as soon as possible.
E08	"Low voltage Warning"	When the power supply gets lower than 170 V the appliance gets to steady position.	<ul style="list-style-type: none"><li>• This is not a failure. This prevents any damages on the compressor. This warning will off after the voltage gets required level.</li><li>• <b>If the warning continues, please contact with authorized technical service.</b></li></ul>

E09	Freezer comp. Not Cold enough	This caution will be seen especially after long term of power failure	<ol style="list-style-type: none"> <li>1. Do not freeze the foods that are thaw and use in short time period.</li> <li>2. Set the freezer temperature to colder values or set the super freeze , until the compartment gets to normal temperature.</li> <li>3. Do not put fresh food until this failure is off.</li> <li>4. Please don't open the refrigerator doors frequently until the warning disappears.</li> <li>5. If the warning continues, please contact with authorized technical service.</li> </ol>
E10	"Refrigerator comp. Not Cold enough"	<p>Ideal temperature for Ref. Compartment is +4 °C. If you see this warning your foods have risk of spoiling.</p> <p>This warning becomes visible if electricity is off for a long time (most probably) or the refrigerator is activated for the first time or hot food is loaded to the appliance.</p>	<ol style="list-style-type: none"> <li>1. Set the refrigerator temperature to colder values or set the super cooling mode until the compartment gets to normal temperature.</li> <li>2. Do not open the door much until this failure is off.</li> <li>3. Please empty the location at the front area of air duct channel holes.</li> <li>4. Please be careful while loading the appliance in order not to avoid the ventilation at the areas which are very close to the sensor.</li> <li>5. Please don't open the refrigerator doors frequently until the warning disappears.</li> <li>6. If the warning continues, please contact with authorized technical service.</li> </ol>
E11	Refrigerator comp. too Cold	<p>The foods starts to freeze because of the too much cold temperature.</p> <p>This warning means that the temperature of the cooler compartment is very low. Therefore, this ambient condition may lead to the freezing of foods in the compartment.</p>	<ol style="list-style-type: none"> <li>1. Check if the "Super cooling mode" is on.</li> <li>2. Decrease the refrigerator temperature values.</li> <li>3. If the warning continues, please contact with authorized technical service.</li> </ol>

## **What to do if your refrigerator does not operate:**

### **Check that:**

- Your fridge is plugged in and switched on,
- The fuse is not blown and there is not a power cut,
- Is the temperature adjustment right?
- The socket is no longer functioning. To check this, plug in an appliance that you know is working into the same socket.

## **What to do if your refrigerator performs poorly:**

### **Check that:**

- You have not overloaded the appliance,
- The doors are fully closed ,
- There is no dust on the condenser,
- There is enough space for air circulation at the rear and side of the appliance.

## **If your fridge is operating too loudly:**

### **Normal Noises**

#### **Cracking (Ice cracking) noise:**

- During automatic defrosting.
- When the appliance is cooled or warmed (due to expansion of appliance material).

**Click noise:** Heard when the thermostat switches the compressor on/off.

#### **Compressor noise:**

- **Normal motor noise:** This noise means that the compressor is operating normally
- The compressor may cause more noise for a short time when it is first activated.

**Bubbling noise and splash:** This noise is caused by the flow of the refrigerant in the tubes of the system.

**Water flow noise:** Normal flow noise of water flowing to the evaporation container during defrosting. This noise can be heard during defrosting.

**Air blow noise (Normal fan noise):** This noise can be heard during the normal operation of system due to the circulation of air.

## **If humidity builds up inside the fridge;**

- Is all the food packed properly? Are all containers thoroughly dried before placing them in the fridge?
- Are the fridge doors opened frequently? Humidity of the room gets into the fridge each time the doors are opened. Humidity build up will be faster if you open the doors more frequently, especially if the humidity of the room is high.
- Build up of water drops on the rear wall after automatic defrosting is normal. (in Static Models)

## **If the doors are not opened and closed properly;**

- Do the food packages prevent closing of the door?
- Are the door compartments, shelves and drawers placed properly?
- Are door gaskets broken or torn?
- Is your fridge on a level surface?

**If the edges of fridge cabinet that the door joint contact are warm;**

Especially in summer (hot weather), the surfaces that the joint contact may get warmer during the operation of the compressor. This is normal.

**IMPORTANT NOTES:**

- If the appliance is switched off or unplugged, wait at least 5 minutes before plugging the appliance in or restarting it in order not to damage the compressor.
- If the appliance is not used for long time (for example during holidays) defrost and clean the refrigerator, leaving the door open to prevent the formation of mildew and smell.
- If the problem persists after you have followed all the instructions above, please consult the nearest Authorised Service.
- The appliance you have purchased is designed for home use and can be used only at home and for the stated purposes. It is not suitable for commercial or common use. If the consumer uses the appliance in a way that does not comply with these instructions, we emphasise that the producer and the dealer shall not be responsible for any repair or failure within the guarantee period.
- The lifetime of your appliance stated and declared by the Department of the Industry is 10 years (the period for retaining parts required for the proper functioning of the appliance).

## Tips for saving energy

- 1– Install the appliance in a cool, well ventilated room , but not in direct sunlight and not near heat source (radiator, cooker.. etc. ). Otherwise use an insulating plate.
- 2– Allow warm food and drinks to cool down outside the appliance.
- 3– When thawing frozen food, place it in the refrigerator compartment. The low temperature of the frozen food will help to cool the refrigerator compartment when it is thawing. So it reduces the energy requirements.
- 4– When placing, drinks and liquids they must be covered. Otherwise humidity increases at the appliance. Therefore the working time gets longer. Also covering drinks and liquids helps preserve the smell and taste.
- 5– When placing food and drinks, open the appliance door as briefly as possible.
- 6– Keep the covers closed of any different temperature compartment in the appliance (crisper, chiller ...etc. ).
- 7– Door gasket must be clean and pliable. **In case of wear, if your gasket is detachable, replace the gasket. If not detachable, you have to replace the door**



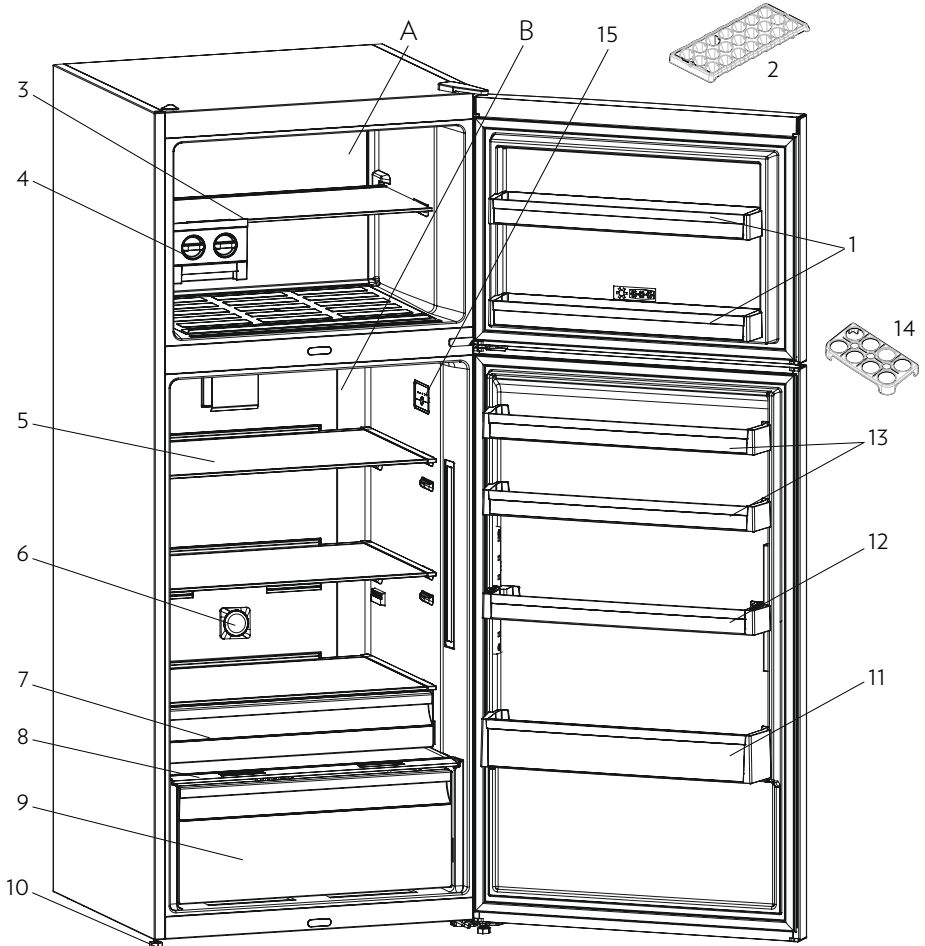

This presentation is only for information about the parts of the appliance.

Parts may vary according to the appliance model.

- A. Freezer compartment
- B. Fridge compartment

- 1. Freezer door shelves\*
- 2. Ice box tray\*
- 3. Freezer shelf
- 4. Icematic\*
- 5. Fridge compartment shelves
- 6. Ioniser \*

- 7. Chiller shelf \*
- 8. Glass shelf over the crisper
- 9. Crisper
- 10. Levelling feet
- 11. Bottle shelf
- 12. Adjustable door shelf \*
- 13. Door shelves
- 14. Egg holder\*
- 15. Thermostat box / Interior display

\* In some models

## Dimensions

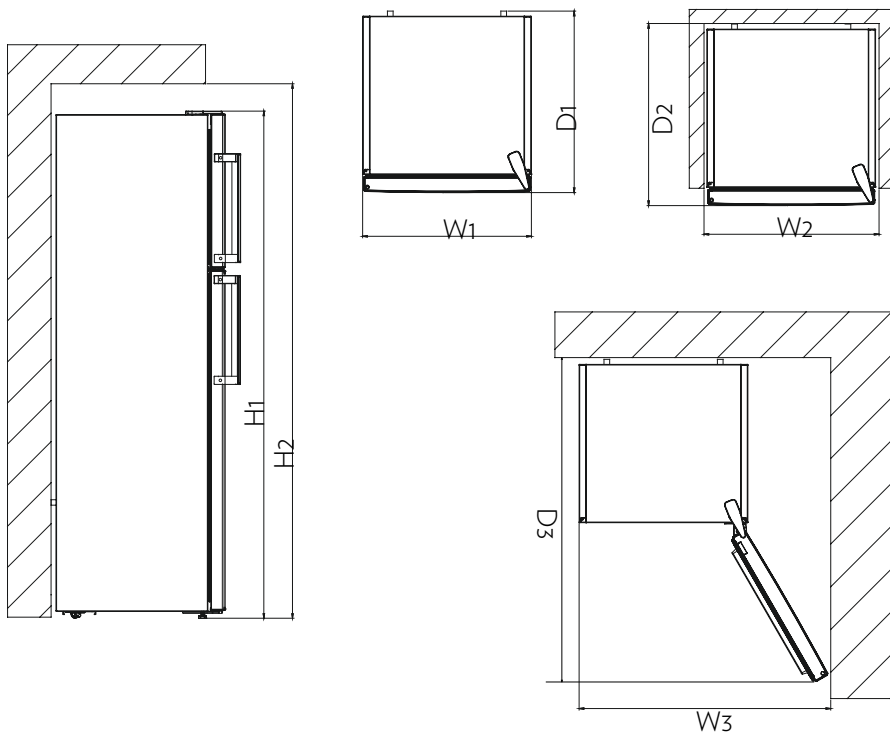

<b>Overall dimensions <sup>1</sup></b>		
H1	mm	1860
W1	mm	760
D1	mm	750
<b>Space required in use <sup>2</sup></b>		
H2	mm	2010
W2	mm	860
D2	mm	790
<b>Overall space required in use <sup>3</sup></b>		
W3	mm	1368,1
D3	mm	1467,5

## **PART - 8. TECHNICAL DATA**

The technical information is situated in the rating plate on the internal side of the appliance and on the energy label.

The QR code on the energy label supplied with the appliance provides a web link to the information related to the performance of the appliance in the EU EPREL database.

Keep the energy label for reference together with the user manual and all other documents provided with this appliance.

It is also possible to find the same information in EPREL using the link <https://eprel.ec.europa.eu> and the model name and product number that you find on the rating plate of the appliance. See the link [www.theenergylabel.eu](http://www.theenergylabel.eu) for detailed information about the energy label.

## **PART - 9. INFORMATION FOR TEST INSTITUTES**

Appliance for any EcoDesign verification shall be compliant with EN 62552.

Ventilation requirements, recess dimensions and minimum rear clearances shall be as stated in this User Manual at **Chapter 7**. Please contact the manufacturer for any other further information, including loading plans.

## **PART - 10. CUSTOMER CARE AND SERVICE**

Always use original spare parts.

When contacting our Authorised Service Centre, ensure that you have the following data available: Model, Serial Number and Service Index.

The information can be found on the rating plate. Subject to change without notice.

The original spare parts for some specific components are available for a minimum of 7 or 10 years, based on the type of component, from the placing on the market of the last unit of the model.

**Visit our website to:**

**Get User manuals:** <https://www.smeg.com/info/download-manuals>

**Get Service information:** <https://www.smeg.com/services/customer-service>