

Contents

1 Instructions	32
1.1 General safety instructions	32
1.2 Manufacturer liability	35
1.3 Appliance purpose	35
1.4 Identification plate	36
1.5 This user manual	36
1.6 Disposal	36
1.7 How to read the user manual	37
2 Description	38
2.1 General Description	38
2.2 Symbols	39
3 Use	40
3.1 Instructions	40
3.2 First use	40
3.3 Using the hob	41
4 Cleaning and maintenance	43
4.1 Instructions	43
4.2 Cleaning the appliance	43
5 Installation	45
5.1 Safety instructions	45
5.2 Section cut from the work surface	45
5.3 Mounting	46
5.4 Fixing brackets	47
5.5 Gas connection	48
5.6 Adaptation to different types of gas	50
5.7 Electrical connection	56
5.8 Instructions for the installer	57

These instructions apply only for the destination countries listed on the appliance's data plate.
This is a class 3 built in hob.

We advise you to read this manual carefully, which contains all the instructions for maintaining the appliance's aesthetic and functional qualities.

For further information on the product: www.smeg.com



Instructions

1 Instructions

1.1 General safety instructions

Risk of personal injury

- During use the appliance and its accessible parts become very hot. Never touch the heating elements during use.
- Protect your hands by wearing oven gloves when moving food inside the oven.
- Never try to put out a fire or flames with water: Turn off the appliance and smother the flames with a fire blanket or other appropriate cover.
- This appliance may be used by children aged at least 8 and by people of reduced physical, sensory or mental capacity, or lacking in experience in the use of electrical appliances, provided that they are supervised or instructed by adults who are responsible for their safety.
- Children must not play with the appliance.
- Keep children under the age of eight at a safe distance unless they are constantly supervised.
- Keep children under the age of 8 away from the appliance when it is in use.
- Cleaning and maintenance must not be carried out by unsupervised children.
- Make sure that the flame-spreader crowns are correctly positioned in their housings with their respective burner caps.
- Be aware of how rapidly the cooking zones heat up. Do not place empty pans on the heat. Danger of overheating.
- Fats and oils can catch fire if they overheat. Do not leave the appliance unattended while preparing foods containing oils or fats. If fats or oils catch fire, never put water on them. Place the lid on the pan and turn off the relevant cooking zone.
- The cooking process must always be monitored. A short cooking process must be continuously monitored.
- Do not place metal objects, such as dishes or cutlery, on the hob surface during use as they may overheat.
- Do not insert pointed metal objects (cutlery or utensils) into the slots in the appliance.
- Do not pour water directly onto very hot trays.
- Do not use aerosols in the vicinity of this appliance whilst it is in use.



- Switch off the appliance immediately after use.
- Do not modify this appliance.
- Do not try to repair the appliance yourself or without the intervention of a qualified technician.
- Do not pull the cable to remove the plug.
- If the power supply cable is damaged, contact technical support immediately and they will replace it.
- Cooking vessels or griddle plates should be placed inside the perimeter of the hob.
- All pans must have smooth, flat bottoms.
- If any liquid does boil over or spill, remove the excess from the hob.
- Take care not to spill acid substances such as lemon juice or vinegar on the hob.
- Do not put empty pans or frying pans on switched on cooking zones.

Risk of damaging the appliance

- Do not seat on the appliance.
- Do not use steam jets to clean the appliance.
- Do not obstruct ventilation openings and heat dispersal slots.
- Never leave the appliance unattended during cooking operations where fats or oils could be released, as these could then heat up and catch fire. Be very careful.
- Never leave objects on the cooking surface.
- Do not use the appliance to heat rooms for any reason.
- Do not spray any spray products near the oven.
- Do not use plastic cookware or containers when cooking food.
- Do not use steam jets to clean the appliance.
- Do not use rough or abrasive materials or sharp metal scrapers.
- Do not use cleaning products containing chlorine, ammonia or bleach on parts made of steel or that have metallic surface finishes (e.g. anodizing, nickel- or chromium-plating).
- Do not use abrasive or corrosive detergents (e.g. scouring powders, stain removers and metallic sponges) on glass parts.
- Do not wash removable parts such as the hob pan support grids, flame-spreader crowns and burner caps in the dishwasher.



Instructions

Installation

- This appliance **must not be installed** in a boat or caravan.
- The appliance must not be installed on a pedestal.
- Position the appliance into the cabinet cut-out with the help of a second person.
- To avoid potential overheating, the appliance must not be installed behind a decorative door or a panel.
- Always use any necessary/required personal protective equipment (PPE) before performing any work on the appliance (installation, maintenance, positioning or movement).
- Before performing any work on the appliance, switch off the power supply.
- Have qualified personnel carry out installation and assistance interventions according to the standards in force.
- Have the gas connection performed by authorised technical personnel. Installation with a hose must be carried out so that the length of the piping does not exceed 2 metres when fully extended for steel hoses.
- The hoses should not come into contact with moving parts and should not be crushed in any way.
- If required, use a pressure regulator that complies with current regulations.
- After carrying out any operation, check that the tightening torque of gas connections is between 10 Nm and 15 Nm.
- At the end of the installation, check for any leaks with a soapy solution, never with a flame.
- Have the electrical connection performed by authorised technical personnel.
- The appliance must be connected to earth in compliance with electrical system safety standards.
- Use cables withstanding a temperature of at least 90 °C.
- The tightening torque of the screws of the terminal supply wires must be 1.5 - 2 Nm.
- If it is necessary to replace the power cable, this must only be performed by a qualified technician.
- Before installation, make sure that the local distribution conditions (nature and pressure of the gas) and the adjustment of the appliance are compatible;



- The adjustment conditions for this appliance are shown on the gas setting label.
- This appliance is not connected to an exhaust system for combustion products. It must be installed and connected in compliance with the current installation regulations. Special attention should be paid to the relevant requirements as for ventilation

For this appliance

- Do not obstruct ventilation openings and heat dispersal slots.
- Do not insert pointed metal objects (cutlery or utensils) into the slots in the appliance.
- Do not use the appliance to heat rooms for any reason.
- The appliance is not designed to operate with external timers or with remote-control systems.

1.2 Manufacturer liability

The manufacturer declines all liability for damage to persons or property caused by:

- use of the appliance other than the one envisaged;
- non-observance of the user manual provisions;
- tampering with any part of the appliance;
- use of non-original spare parts.

1.3 Appliance purpose

- This appliance is intended for cooking food in the home environment. Every other use is considered improper.
- The appliance is not designed to operate with external timers or with remote-control systems.



Instructions

1.4 Identification plate

The identification plate bears the technical data, serial number and brand name of the appliance. Do not remove the identification plate for any reason.

1.5 This user manual

This user manual is an integral part of the appliance and must therefore be kept in its entirety and within the user's reach for the whole working life of the appliance.

- Read this user manual carefully before using the appliance.

1.6 Disposal



This appliance must be disposed of separately from other waste (Directives 2002/95/EC, 2002/96/EC, 2003/108/EC). The appliance does not contain substances in quantities sufficient to be considered hazardous to health and the environment, in accordance with current European directives.

To dispose of the appliance:

- Cut the power supply cable and remove it along with the plug.

- Consign the appliance to the appropriate selective collection centres for electrical and electronic equipment waste, or deliver it back to the retailer when purchasing an equivalent product, on a one for one basis.

Our appliances are packed in non-polluting and recyclable materials.

- Consign the packing materials to the appropriate selective collection centres.



Plastic packaging Danger of suffocation

- Do not leave the packaging or any part of it unattended.
- Do not let children play with the packaging plastic bags.



Power voltage Danger of electrocution

- Disconnect the main power supply.
- Disconnect the power cable from the electrical system.



1.7 How to read the user manual

This user manual uses the following reading conventions:

Instructions



General information on this user manual, on safety and final disposal.

Description



Description of the appliance and its accessories.

Use



Information on the use of the appliance and its accessories, cooking advice.

Cleaning and maintenance



Information for proper cleaning and maintenance of the appliance.

Installation



Information for the qualified technician: installation, operation and inspection.



Safety instructions



Information



Advice

1. Use instruction sequence.
- Single use instruction.



Description

2 Description

2.1 General Description

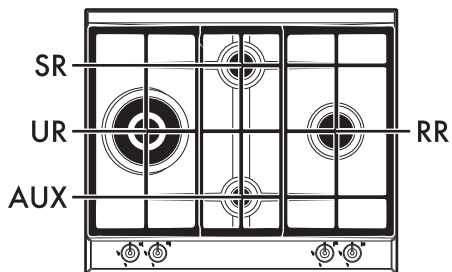
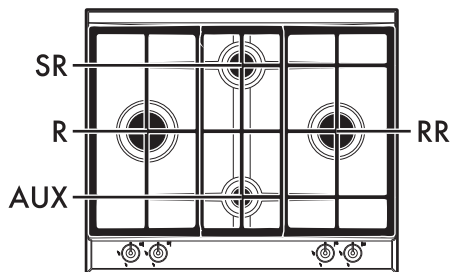
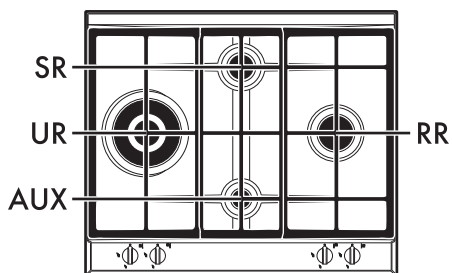
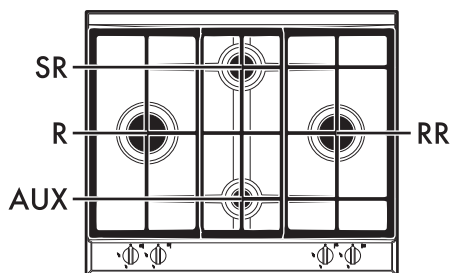

60 cm

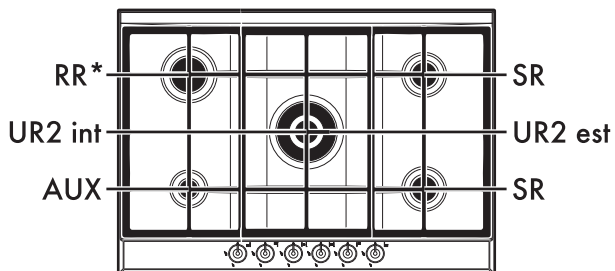
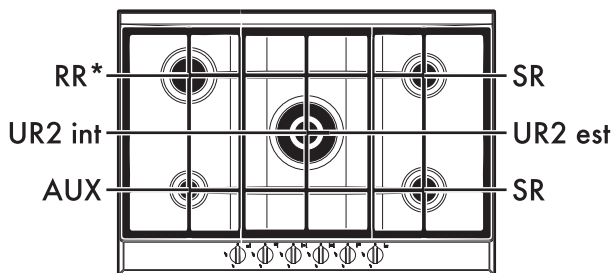

72 cm



- AUX** = Auxiliary
- SR** = Semi-rapid
- RR** = Reduced rapid
- RR*** = Reduced rapid
- R** = Rapid
- UR** = Ultra rapid
- UR2 int** = internal crown ultra rapid
- UR2 est** = external crown ultra rapid





2.2 Symbols

Cooking zones

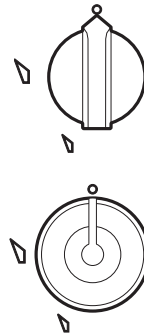
- | Front left
- | Centre left
- | Rear left
- | | Central internal
- | | Central external
- | | Front right
- | | Central right
- | | Rear right

Burner knobs



Useful for lighting and adjusting the hob burners. Press and turn the knobs anti-clockwise to the value  to light the relative burners. Turn the knobs to the zone between the maximum  and minimum  setting to adjust the flame. Return the knobs to the  position to turn off the burners.

(on certain models only)

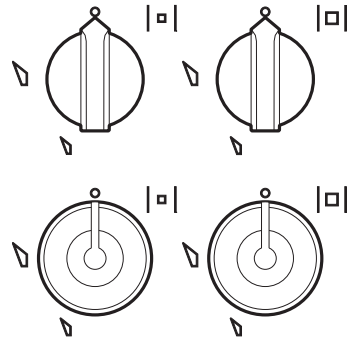

Double-crown burners comprise an auxiliary and a rapid burner. It is controlled by two different knobs which permit to use both burners at the same time or to select one or the other as required.



3 Use

3.1 Instructions



Improper use Danger of burns

- Make sure that the flame-spreader crowns are correctly positioned in their housings with their respective burner caps.
- Oils and fat could catch fire if overheated. Be very careful.
- Do not leave the appliance unattended during cooking operations where fats or oils could be released.
- Do not spray any spray products near the appliance.
- Do not touch the appliance's heating elements when it is running. Leave them to cool before cleaning.
- Do not allow children younger than 8 years old to come near the appliance when in operation.



Improper use Risk of damage to surfaces

- Do not use aluminium foil to cover the burners or hob body.
- The cooking vessels or griddle plates should be placed inside the perimeter of the hob.
- All pans must have smooth, flat bottoms.
- If any liquid does boil over or spill, remove the excess from the hob.

3.2 First use

1. Remove any protective film from the outside or inside of the appliance, including accessories.
2. Remove any labels (apart from the technical data plate) from accessories.
3. Remove and wash all the appliance accessories (see 4 Cleaning and maintenance).



3.3 Using the hob

All the appliance's control and monitoring devices are located together on the front panel. The burner controlled by each knob is shown next to the knob. The appliance is equipped with an electronic ignition device. Simply press the knob and turn it anti-clockwise to the maximum flame symbol, until the burner lights. If the burner does not light in the first 15 seconds, turn the knob to  and wait 60 seconds before trying again. After lighting, keep the knob pressed in for a few seconds to allow the thermocouple to heat up. The burner may go out when the knob is released: in this case, the thermocouple has not heated up sufficiently. Wait a few moments and repeat the operation. Keep the knob pressed in longer.



In case of an accidental switching off, a safety device will be tripped, cutting off the gas supply, even if the gas tap is open. Return the knob to  and wait at least 60 seconds before lighting it again.

Correct positioning of the grids

Under the grids there are silicone rests with a hole that must be centred onto the matching fixing pins on the surface.

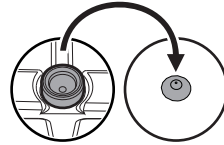

Make sure that the grids are simply centred on their respective burners, without forcing the burners to be raised or tilted. If they are, repeat the positioning procedure.

If you find that a pan is particularly unstable, make sure that the grids have not been positioned incorrectly.

Correct positioning of the flame-spreader crowns and burner caps

Before lighting the hob burners, make sure that the flame-spreader crowns are correctly positioned in their housings with their respective burner caps. Make sure that the holes in the burners are aligned with the igniters and thermocouples. Also ensure that the flame-spreader crowns are correctly engaged in the burner holes.

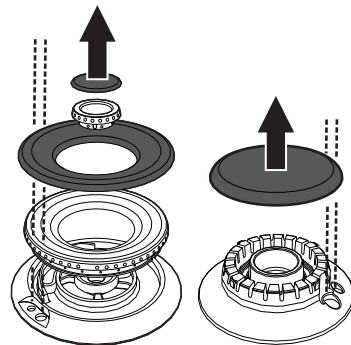



Use

Practical tips for using the hob

For better burner efficiency and to minimise gas consumption, use pans with lids and of suitable size for the burner, so that flames do not reach up the sides of the pan. Once the contents come to the boil, turn down the flame far enough to ensure that the liquid does not boil over.



Cookware diameters:

- **AUX:** 7 - 18 cm.
- **SR:** 10 - 24 cm.
- **RR - RR*:** 12 - 24 cm.
- **R:** 14 - 26 cm.
- **UR:** 12 - 26 cm
- **UR2:** 12 - 26 cm.

To prevent burns or damage to the hob or the counter top during cooking, all pans or griddles must be placed inside the perimeter of the hob.

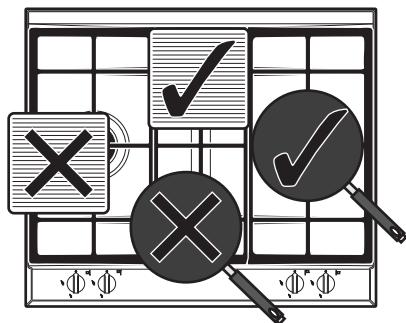

Limitations on griddle use

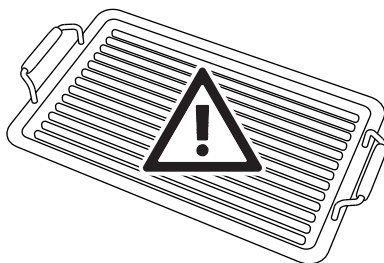

Improper use
Risk of damage to surfaces

- Do not use cast-iron griddles.

A few precautions are necessary if you wish to use a griddle:

- Use aluminium griddles, including those with anti-stick coating, with dimensions not exceeding 35 x 26 cm;
- Aluminium griddles with Teflon anti-stick coating should be pre-heated for a maximum of 5 minutes in order to avoid damage to the appliance and the Teflon coating. After pre-heating, place the foodstuffs on the griddle to cook them; do not exceed 40 minutes of total use for the griddle.
- Do not allow the burner flames to extend beyond the edge of the griddle;
- Leave a gap of at least 150 mm between the edge of the griddle and the side wall;
- Do not place the griddle over more than one burner at the same time.



4 Cleaning and maintenance

4.1 Instructions



Improper use
Risk of damage to surfaces

- Do not use steam jets for cleaning the appliance.
- Do not use cleaning products containing chlorine, ammonia or bleach on steel parts or parts with metallic finishes on the surface (e.g. anodizing, nickel- or chromium-plating).
- Do not use abrasive or corrosive detergents on glass parts (e.g. powder products, stain removers and metallic sponges).
- Do not use rough or abrasive materials or sharp metal scrapers.
- Do not wash the removable components such as the hob grids, flame-spreader crowns and burner caps in a dishwasher.

4.2 Cleaning the appliance

To keep the surfaces in good condition, they should be cleaned regularly after use. Let them cool first.

Ordinary daily cleaning

Always use only specific products that do not contain abrasives or chlorine-based acids.

Pour the product onto a damp cloth and wipe the surface, rinse thoroughly and dry with a soft cloth or a microfibre cloth.

Food stains or residues

Do not use metallic sponges or sharp scrapers as they will damage the surfaces.

Use ordinary non-abrasive products with the aid of wooden or plastic utensils if necessary. Rinse thoroughly and dry with a soft cloth or a microfibre cloth.

Do not allow residues of sugary foods (such as jam) to set inside the oven. If left to set for too long, they might damage the enamel lining of the oven.



Cleaning and maintenance

Cooking hob grids

Remove the grids and clean them with lukewarm water and non-abrasive detergent. Make sure to remove any encrustations. Dry them thoroughly and return them to the hob.

i

Continuous contact between the grids and the flame can cause modifications to the enamel over time in those parts exposed to heat. This is a completely natural phenomenon which has no effect on the operation of this component.

Flame-spreader crowns and burner caps

For easier cleaning, the flame-spreader crowns and the burner caps can be removed. Wash them in hot water and non-abrasive detergent. Carefully remove any encrustation, then wait until they are perfectly dry. Refit the flame-spreader crowns making sure that they are correctly positioned in their housings with their respective burner caps.

Igniters and thermocouples

For correct operation the igniters and thermocouples must always be perfectly clean. Check them frequently and clean them with a damp cloth if necessary. Remove any dry residues with a wooden toothpick or a needle.

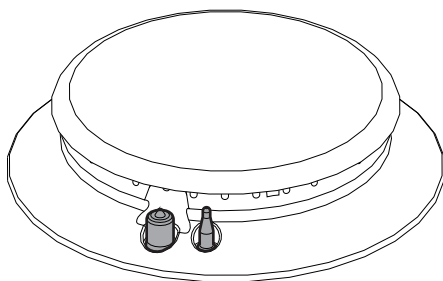



5 Installation

5.1 Safety instructions



Heat production during appliance operation
Risk of fire

- Check that the piece of furniture material is heat resistant.
- Check that the piece of furniture has the required slots.

Veneers, adhesives or plastic coatings on adjacent furniture should be temperature-resistant (>90 °C), otherwise they might warp over time.



The minimum clearance between a ventilation hood and the cooking surface must be at least the distance indicated in the ventilation hood installation instructions.

The minimum distances must also be respected for the edges of the hob on the back as indicated in the mounting illustrations.

5.2 Section cut from the work surface



The following operation requires building and/or carpentry work and must therefore be carried out by a competent tradesman.

Installation can be carried out on various materials such as masonry, metal, solid wood or plastic laminated wood as long as they are heat resistant (>90 °C).

Create an opening with the dimensions shown in the figure in the work surface of the piece of furniture.

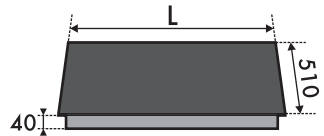

L (mm)	X (mm)	Y (mm)
600 - 720	555÷560	478÷482

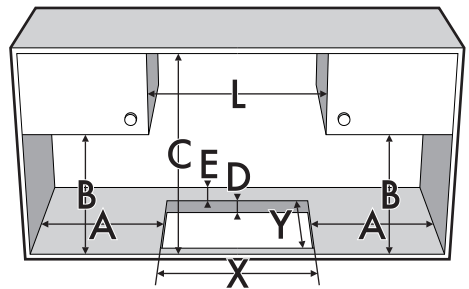

A (mm)	B (mm)	C (mm)*	D (mm)	E (mm)
min 150	min 460	min 750	20÷60	min 50

*If there is a kitchen unit positioned above the hob. In the case of a hood, refer to the measurements indicated in the relative manual.



Installation

5.3 Mounting

Over built-in oven

The distance between the hob and the kitchen furniture or other installed appliances must be enough to ensure sufficient ventilation and air discharge. If installed above an oven, a space must be left between the bottom of the hob and the top of the appliance installed below.

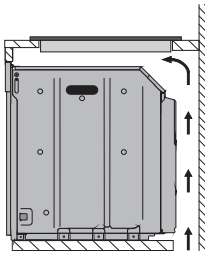

opens on bottom

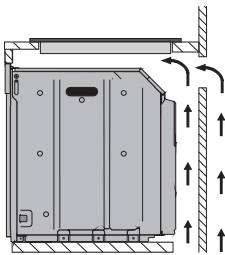

opens on bottom and on rear



If installed on top of an oven, the latter must be equipped with a cooling fan.

Over empty kitchen unit or drawers

If there are other pieces of furniture (lateral walls, drawers, etc.), dishwashers or fridges under the hob, a double-layer wooden base must be installed at least **10 mm** from the bottom of the hob to avoid any accidental contact. It must only be possible to remove the double-layer base using suitable equipment.

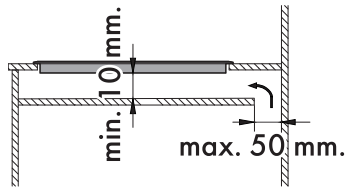
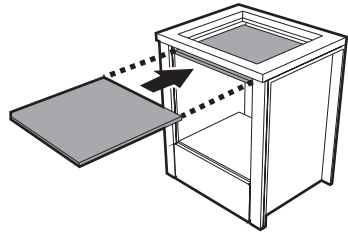

opens on bottom

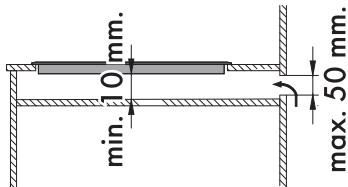

opens on rear



Failure to install the double-layer wooden base exposes the user to possible accidental contact with sharp or hot parts.



Hob seal

To prevent leakage of liquid between the frame of the hob and the work surface, put the insulating seal provided in position before assembly.

1. Refer to the dimensions in the figure, bearing in mind that the long front side must brush against the hole.

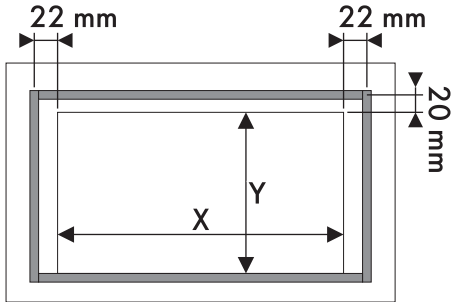

2. Use light pressure to make the seal stick to the edge around the hole cut in the worktop.
3. Carefully trim the surplus edge away from the seal.

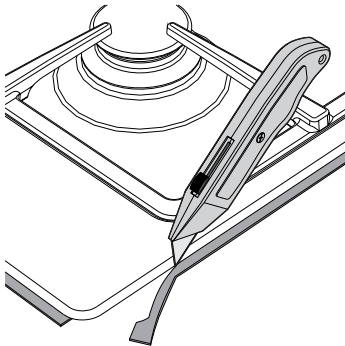

5.4 Fixing brackets

Screw the fixing brackets (A) into the holes on the sides of the bottom casing to properly fasten the hob to the structure.

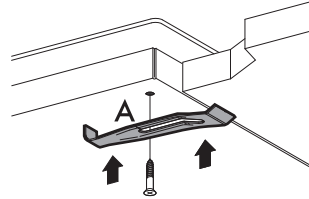

Do not use silicone to secure the hob. This would make it impossible to remove the hob, if necessary, without damaging it.



Installation

5.5 Gas connection



**Gas leak
Danger of explosion**

- After carrying out any operation, check that the tightening torque of gas connections is between 10 Nm and 15 Nm.
- If required, use a pressure regulator that complies with current regulations.
- At the end of the installation, check for any leaks with a soapy solution, never with a flame.
- The hoses should not come into contact with moving parts and should not be crushed in any way.
- The adjustment conditions for this appliance are shown on the gas setting label.

General information

Connection to the gas mains can be made using a rigid copper pipe or a continuous wall flexible steel hose in compliance with the provisions established by the applicable standard.

For supplying it with other types of gas, see chapter "5.6 Adaptation to different types of gas". The gas inlet connection is threaded 1/2" external gas (ISO 228-1).

Connection with a flexible steel hose

Make the connection to the gas mains using a continuous wall flexible steel hose whose specifications comply with the applicable standard.

Carefully screw the connector **3** to the gas connector **1** of the appliance, placing the seal **2** between them.

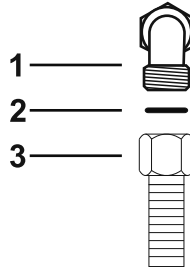

Connection with a flexible steel hose with conical fitting

Make the connection to the gas mains using a continuous wall flexible steel hose whose specifications comply with the applicable standard.

Carefully screw the hose connector **3** to the appliance's gas connector **1** (1/2" thread ISO 228-1), placing the supplied seal **2** between them. Apply insulating material to the thread (1/2" ISO 7.1) of connector **3**, then tighten the flexible steel hose **4** to the connector **3**.

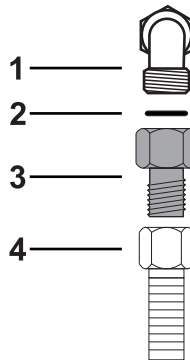



Connection to LPG

Use a pressure regulator and make the connection on the gas cylinder following the guidelines set out in the standards in force.

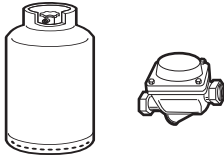

The supply pressure must comply with the values indicated in the table in "Gas types and Countries".

Room ventilation

The appliance should be installed in rooms that have a permanent air supply in accordance with the standards in force. The room where the appliance is installed must have enough air flow for the regular combustion of gas and the necessary air change in the room itself. The air vents, protected by grilles, must be the right size to comply with current regulations and positioned so that no part of them is obstructed, not even partially.

The room must be kept adequately ventilated in order to eliminate the heat and humidity produced by cooking: in particular, after prolonged use, you are recommended to open a window or to increase the speed of any fans.

Extraction of the combustion products



This appliance is not connected to an exhaust system for combustion products. It must be installed and connected in compliance with the current installation regulations. Special attention should be paid to the relevant requirements as for ventilation.

The combustion products may be extracted by means of hoods connected to a natural draught chimney whose efficiency is certain or via forced extraction. An efficient extraction system requires precision planning by a specialist qualified in this area and must comply with the positions and distances indicated by the applicable standards.

When the job is complete, the installer must issue a certificate of conformity.

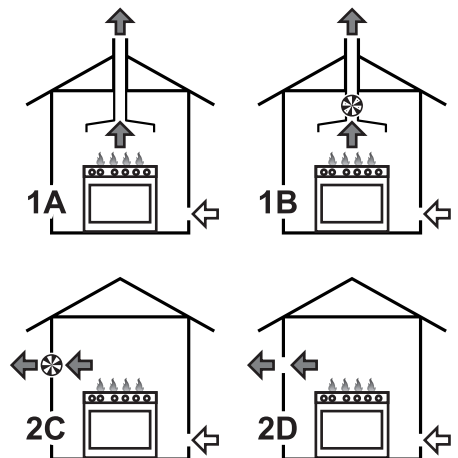



Installation

- 1 Extraction using a hood
- 2 Extraction without a hood

- A Single natural draught chimney
- B Single chimney with extractor fan
- C Directly outdoors with wall- or window-mounted extractor fan
- D Directly outdoors through wall



Air



Combustion products



Extractor fan

5.6 Adaptation to different types of gas

If other types of gas are to be used, the nozzles must be replaced and the primary air must be adjusted. In order to replace the nozzles and adjust the burners, the hob top must be removed.

Removing the hob top

- 1. Remove the grids from the hob.

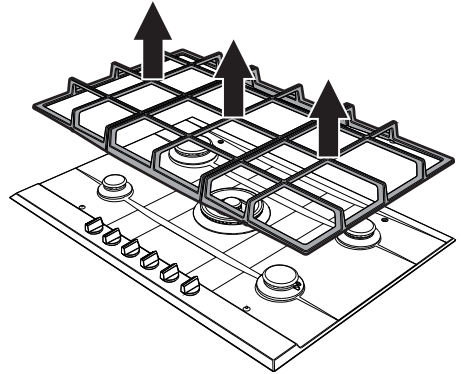

- 2. Remove the flame-spreader crowns and relative burner caps.

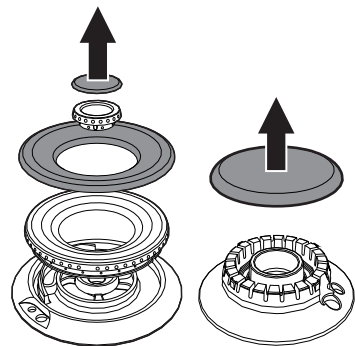



3. Pull the knobs upwards to remove them.

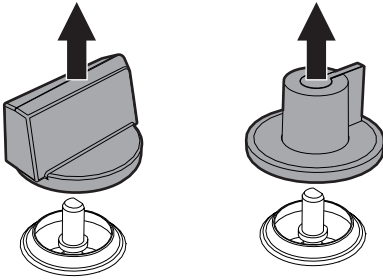

5. The two rear screws need to be removed only on 70 cm models.

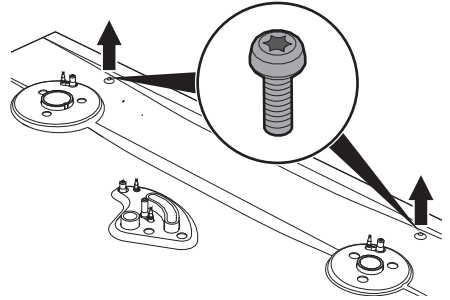

4. Remove the screws fastening the top and the plates corresponding to each burner zone.

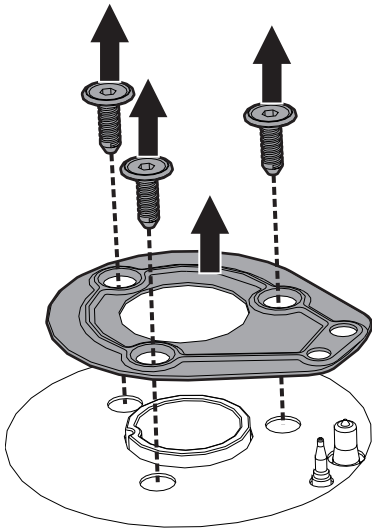

6. Remove the top.

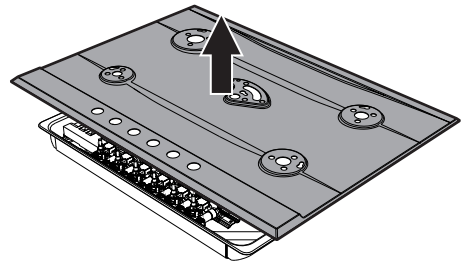

EN



Installation

Replacing nozzles

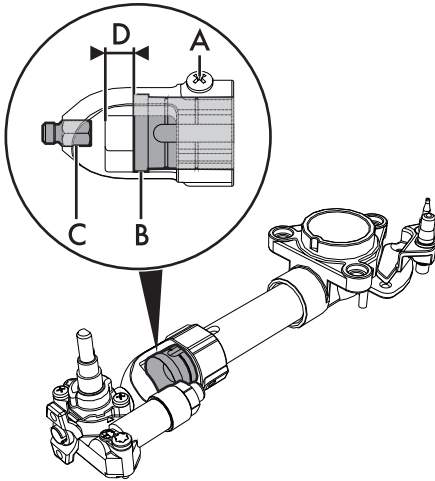

1. Unscrew screw **A** and push air regulator **B** as far as it will go.
2. Use a spanner to remove the nozzles **C** and install the new ones for the required gas supply, following the indications given in the relevant table (see "Gas types and Countries").



The nozzle tightening torque must be no more than 3 Nm.

3. Adjust the air flow by moving the air regulator **B** to obtain the distance **D** given in the relevant table (see "Gas types and Countries").
4. After adjusting each burner, reassemble the appliance correctly.

Adjusting the minimum setting for natural or city gas

Light the burner and turn it to the minimum position. Extract the gas tap knob and turn the adjustment screw next to the tap rod (depending on the model) until the correct minimum flame is achieved.

Refit the knob and verify that the burner flame is stable. Turn the knob rapidly from the maximum to the minimum setting: the flame should not go out. Repeat the operation on all gas taps.

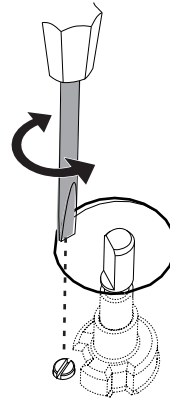

Adjusting the minimum setting for LPG

Tighten the screw located at the side of the tap rod clockwise all the way.



Following adjustment to a gas other than the one originally set in the factory, replace the gas setting label on the appliance with the one corresponding to the new gas. The label is inserted inside the nozzle pack (where present).



Lubricating the gas taps

Over time the gas taps may become difficult to turn and get blocked. Clean them internally and replace the lubrication grease.



Lubrication of the gas taps should be performed by a specialised technician.



It is possible to identify the available gas types based on the country the appliance is to be installed in. Refer to the heading number to identify the correct values in the "Burner and nozzle characteristics tables".

EN

Gas types and Countries

Gas types		IT	GB-IE	FR-BE	DE	AT	ES	PT	SE	RU	DK	PL	HU
1 Natural Gas G20													
G20	20 mbar	•	•		•	•	•	•	•	•	•	•	
G20/25	20/25 mbar			•									
2 Natural Gas G20													
G20	25 mbar												•
3 Natural Gas G25.1													
25.1	25 mbar												•
4 Natural Gas G25													
G25	20 mbar				•								
5 Natural Gas G2.350													
G2.350	13 mbar											•	
6 LPG G30/31													
G30/31	28/37 mbar		•	•			•			•			
G30/31	30/37 mbar	•						•					
G30/31	30/30 mbar								•		•		
7 LPG G30/31													
G30/31	37 mbar											•	
8 LPG G30/31													
G30/31	50 mbar				•	•							
9 Town gas G110													
G110	8 mbar	•							•		•		
10 Town gas G120													
G120	8 mbar								•				



Installation

Burner and nozzle characteristics tables

1	Natural Gas G20 – 20 mbar	AUX	SR	RR	RR*	R	UR	UR2 int.	UR2 ext.
	Rated heating capacity (kW)	1.10	1.70	2.60	2.60	3.10	3.50	1.00	3.20
	Nozzle diameter (1/100 mm)	76	95	115	115	126	135	73	130
	Reduced flow rate (W)	400	500	750	750	900	1600	400	1400
	Primary air (mm)	1	0.5	1	1	1	1.5	2	1.5
2	Natural Gas G20 – 25 mbar	AUX	SR	RR	RR*	R	UR	UR2 int.	UR2 ext.
	Rated heating capacity (kW)	1.10	1.70	2.60	2.60	3.10	3.50	1.10	3.10
	Nozzle diameter (1/100 mm)	73	87	110	110	120	126	73	120
	Reduced flow rate (W)	400	500	750	750	900	1600	400	1400
	Primary air (mm)	1	0.5	1	1	1	1.5	1.5	2
3	Natural gas G25.1 – 25 mbar	AUX	SR	RR	RR*	R	UR	UR2 int.	UR2 ext.
	Rated heating capacity (kW)	1.10	1.70	2.60	2.60	3.10	3.50	1.10	3.10
	Nozzle diameter (1/100 mm)	76	98	123	123	135	145	76	135
	Reduced flow rate (W)	400	500	750	750	900	1600	400	1400
	Primary air (mm)	1	0.5	0.5	1	1	1.5	1	2
4	Natural Gas G25 – 20 mbar	AUX	SR	RR	RR*	R	UR	UR2 int.	UR2 ext.
	Rated heating capacity (kW)	1.10	1.70	2.60	2.60	3.10	3.50	1.10	3.10
	Nozzle diameter (1/100 mm)	82	105	126	126	140	150	82	140
	Reduced flow rate (W)	400	500	750	750	900	1600	400	1400
	Primary air (mm)	1	0.5	1	1	1	1.5	2	2.5
5	Natural gas G2.350 – 13 mbar	AUX	SR	RR	RR*	R	UR	UR2 int.	UR2 ext.
	Rated heating capacity (kW)	1.10	1.70	2.60	2.60	3.10	3.50	1.10	3.10
	Nozzle diameter (1/100 mm)	100	126	160	160	175	190	100	175
	Reduced flow rate (W)	400	500	750	750	900	1600	400	1400
	Primary air (mm)	1	0.5	1	1	1	1.5	1.5	1.5
6	LPG G30/31 - 30/37 mbar	AUX	SR	RR	RR*	R	UR	UR2 int.	UR2 ext.
	Rated heating capacity (kW)	1.00	1.70	2.60	2.60	3.10	3.50	1.00	3.20
	Nozzle diameter (1/100 mm)	48	62	76	76	85	87	48	85
	Reduced flow rate (W)	400	500	750	750	1000	1000	400	1400
	Primary air (mm)	1.5	1.5	1.5	1.5	8	3	4	12
	Rated flow rate G30 (g/h)	73	124	189	189	225	254	73	233
	Rated flow rate G31 (g/h)	71	121	186	186	221	250	71	229

Installation



7	LPG G30/31 - 37 mbar	AUX	SR	RR	RR*	R	UR	UR2 int.	UR2 ext.
	Rated heating capacity (kW)	1.10	1.70	2.60	2.60	3.10	3.50	1.00	3.20
	Nozzle diameter (1/100 mm)	48	60	73	73	80	82	45	80
	Reduced flow rate (W)	450	550	750	750	1100	1600	450	1400
	Primary air (mm)	1.5	1.5	1.5	1.5	10	2.5	6	12
	Rated flow rate G30 (g/h)	80	124	189	189	225	254	73	233
	Rated flow rate G31 (g/h)	79	121	186	186	221	250	71	229
8	LPG G30/31 - 50 mbar	AUX	SR	RR	RR*	R	UR	UR2 int.	UR2 ext.
	Rated heating capacity (kW)	1.10	1.70	2.60	2.60	3.10	3.50	1.10	3.10
	Nozzle diameter (1/100 mm)	42	54	67	67	73	76	42	73
	Reduced flow rate (W)	400	500	800	800	1000	1600	400	1400
	Primary air (mm)	1	0.5	1	2	2	1.5	2	12
	Rated flow rate G30 (g/h)	80	124	189	189	225	254	80	225
	Rated flow rate G31 (g/h)	79	121	186	186	221	250	79	221
9	Town gas G110 - 8 mbar	AUX	SR	RR	RR*	R	UR	UR2 int.	UR2 ext.
	Rated heating capacity (kW)	1.10	1.70	2.60	2.60	3.10	3.50	1.00	3.20
	Nozzle diameter (1/100 mm)	132	165	210	210	250	270	132	250
	Reduced flow rate (W)	400	500	750	750	900	1400	400	1200
	Primary air (mm)	0.5	0.5	0.5	1	0.5	1	1	2
10	Town gas G120 - 8 mbar	AUX	SR	RR	RR*	R	UR	UR2 int.	UR2 ext.
	Rated heating capacity (kW)	1.10	1.70	2.60	2.60	3.00	3.50	1.00	3.20
	Nozzle diameter (1/100 mm)	126	165	200	200	230	250	126	230
	Reduced flow rate (W)	400	500	750	750	900	1400	400	1200
	Primary air (mm)	0.5	0.5	0.5	1	1	1.5	1	2.5

The nozzles not provided are available at Authorised Service Centres.



5.7 Electrical connection



**Power voltage
Danger of electrocution**

- Have the electrical connection performed by authorised technical personnel.
- Use personal protective equipment.
- The appliance must be connected to earth in compliance with electrical system safety standards.
- Disconnect the main power supply.
- Do not pull the cable to remove the plug.
- Use cables withstanding a temperature of at least 90 °C.
- The tightening torque of the screws of the terminal supply wires must be 1.5 - 2 Nm.

General information

Check the grid characteristics against the data indicated on the plate.

The identification plate bearing the technical data, serial number and brand name is visibly positioned on the appliance.

Do not remove this plate for any reason.

Perform the ground connection using a wire that is 20 mm longer than the other wires.

The appliance can work in the following modes:

- 220-240 V 1N~

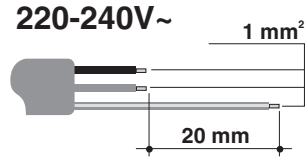

Use a **3 x 1 mm² three-core** cable.



The values indicated above refer to the cross-section of the internal conductor.

Fixed connection

Fit the power line with an omnipolar circuit breaker in compliance with installation regulations.

The circuit breaker should be located near the appliance and in an easily reachable position.

Connection with plug and socket

Make sure that the plug and socket are of the same type.

Avoid using adapters and shunts as these could cause overheating and a risk of burns.

Testing

At the end of installation, carry out a brief inspection test. If the hob fails to operate, after checking that you have carried out the instructions correctly, unplug the appliance and contact Technical Support.



5.8 Instructions for the installer

- The plug must be accessible after installation. Do not bend or trap the power cable.
- The appliance must be installed according to the installation diagrams.
- Do not try to unscrew or force the threaded elbow of the fitting. You may damage this part of the appliance, which may void the manufacturer's warranty.
- Use soap and water to check for gas leaks on all connections. **DO NOT** use naked flames to find leaks.
- Turn on all the burners separately and at then all together to make sure that the gas valve, burner and ignition are working properly.
- Turn the burner knobs to the minimum position and check that the flame is stable for each individual burner and all the burners together.
- If the appliance does not work correctly after having carried out all the checks, contact your local Authorised Service Centre.
- Once the appliance has been installed, please explain to the user how to use it correctly.

