



Questo manuale d'istruzione è fornito da trovaprezzi.it. Scopri tutte le offerte per [Creality K2 Plus Combo](#) o cerca il tuo prodotto tra le [migliori offerte di Stampanti e scanner](#)



K2 Plus

User Manual

K2 Plus 3D Printer

V 1.6_EN

To Our Dear Users

Thank you for choosing Creality. For your convenience, please read through this User Manual before you start and follow the instructions provided carefully.

Creality is always ready to provide you with high-quality services. If you encounter any issues or have any questions when using our products, please use the contact information at the end of this manual to contact us. To further improve your user experience, you can find more about our devices via the following methods:

User manual: You can find instructions and videos in the USB flash disk provided with the printer.

You can also visit our official website (<https://www.creality.com>) to find information regarding software, hardware, contact information, device instructions, device warranty information, and more.

Firmware Upgrade

1. You can upgrade the firmware directly through the device screen;
2. You can upgrade the firmware via the Creality Cloud OTA;
3. Please visit the official website <https://www.creality.com>, click on “Support → Download Center ”, select the corresponding model to download the required firmware, (Or click on “Creality Cloud → Downloads → Firmware”), after installation is complete, you can use it.

Product Operation and After-Sales Service Information

1. You can log in to the Creality Official Wiki (<https://wiki.creality.com>) to explore more detailed after-sales service tutorials.
2. Or contact our after-sales service center at +86 755 3396 5666, or send e-mail to cs@creality.com.



Creality Wiki

1. Do not use the printer in any way other than described herein in order to avoid personal injury or property damage;
2. Do not place the printer near any heat source or flammable or explosive objects. We suggest placing it in a well-ventilated, cool and dustless environment;
3. Do not expose the printer to a violent vibration or any other unstable environment, as this may cause poor print quality;
4. Please use recommended filaments to avoid clogging of the extrusion head and causing damage to the machine;
5. Do not use the power cable of other products during installation. Always use a grounded three-prong power outlet, which accompanies the printer;
6. Do not touch the nozzle and the heated bed during operation to avoid burns or personal injury;
7. Do not wear gloves or wraps while operating the machine to prevent entrapment of movable parts that could cause crushing and cutting injuries to bodily parts;
8. Use the provided tools to clean the filament from the extruder in time taking advantage of the residual temperature after printing. Do not touch the extruder directly when cleaning, otherwise it may cause burns;
9. Clean the printer frequently. Clean the printer body with a dry cloth regularly after powering off the printer, wipe away dust, bonded print filament and foreign objects on the guide rails;
10. Children under 10 years old should not use the printer without supervision, otherwise it may cause personal injury;
11. Users should comply with the laws and regulations of the corresponding countries and regions where the equipment is located (used), abide by professional ethics, pay attention to safety obligations, and strictly prohibit the use of our products or equipment for any illegal purposes; Creality will not be responsible for any violators' legal liability under any circumstance;
12. Tip: Do not plug in or unplug wires on a charged basis.

1. Printer Information	01-06
1.1 Packing List	01-02
1.2 About the Printer	03-04
1.3 Equipment Specifications	05-05
1.4 Equipment Size	06-06
2. Unboxing	07-13
2.1 Remove Screw Rod Holder, Hotbed Locking Screws, Camera cover	07-08
2.2 Install Accessories	09-09
2.3 Connecting CFS	10-11
2.4 Connecting Multiple CFSs for Use	12-12
2.5 Power-on Guide	13-13
3. Product Usage	14-17
3.1 User Interface	14-14
3.2 Loading Filament From Spool Holder	15-16
3.3 Loading Filament From CFS	17-17
4. First Use	18-21
4.1 Filament Setup	18-18
4.2 Print	19-19
4.3 Creality Print Slicing	20-21

1. Printer Information

1.1 Packing List



1 Printer



2 Touch Screen

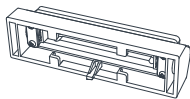

3 Screen Base



4 Spool Holder

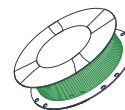

5 Filament



6 PTFE Tube



7 Tool Box



8 Quick Guide

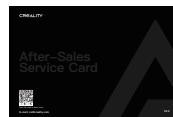











9 After-sales services card

1. Printer Information



TOOL BOX

 <p>1 Nozzle Cleaner</p>	 <p>2 Cutting Plier</p>	 <p>3 Scraper</p>	 <p>4 USB Flash Disk</p>	 <p>5 Screwdriver Bits Kit</p>
 <p>6 Universal Handle</p>	 <p>7 Hexagonal Wrench</p>	 <p>8 Socket Spanner</p>	 <p>9 Lubricating Grease</p>	 <p>10 Glue Stick</p>
 <p>11 Unboxing wrench</p>	<p>Tips: the above accessories are for reference only. Please refer to the physical accessories.</p>			

1. Printer Information

1.2 About the Printer

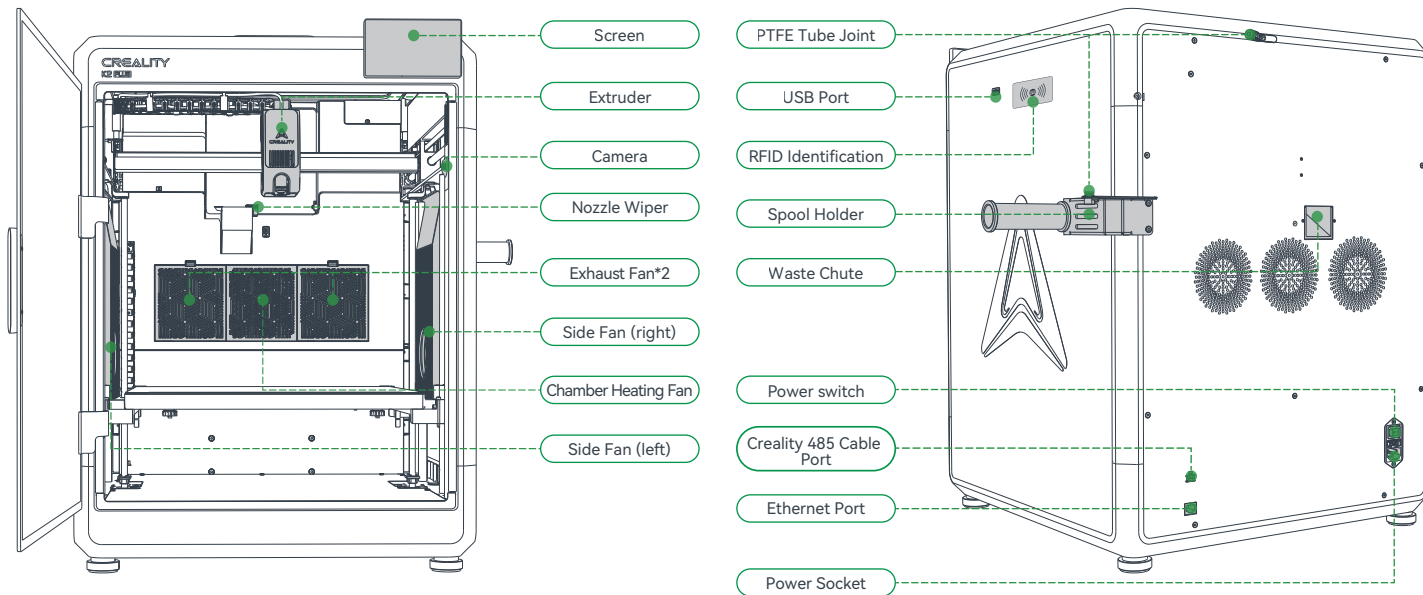

1. Printer Information

1.2 About the Printer

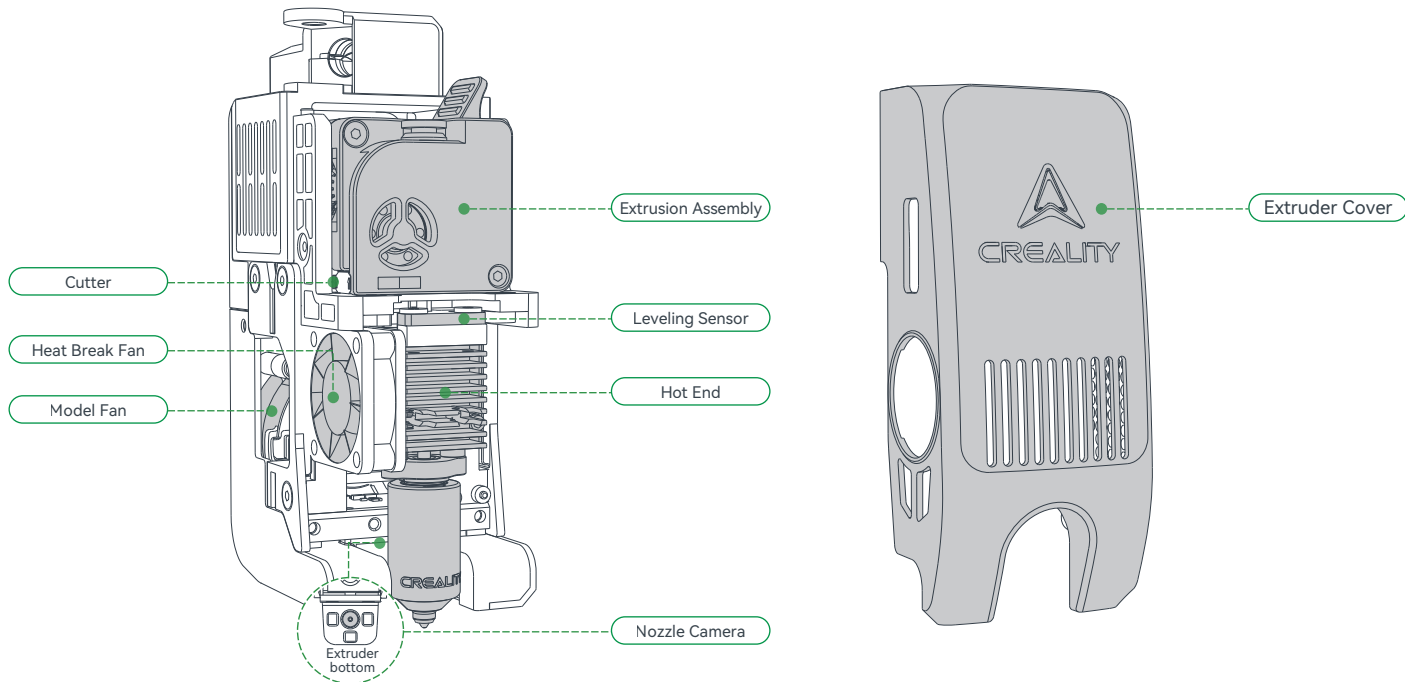

1. Printer Information



1.3 Equipment Specifications

Parameters

Model	K2 Plus
Print size	350*350*350mm
Printer size	495*515*640mm
Single set net weight	35kg
Supported filaments	PLA/ABS/PETG/PA-CF/PLA-CF/PET/ASA/PPA-CF
Extruder type	Proximal dual gear extruder
Printing speed	≤600mm/s
Acceleration	≤30000mm/s ²
Nozzle diameter	0.4mm
Nozzle temperature	≤350°C
Hotbed temperature	≤120°C
Chamber temperature	≤60°C
Rated voltage	100-240V~, 50/60Hz
Screen	4.3-inch color touch screen
Chamber camera	Yes
Nozzle camera	Yes
Power loss recovery	Yes
Automatic refilling	Yes
Lighting lamp	Yes
Air filter	Yes
Active chamber heating	Yes
Slicing software	Creativity Print 5.0 and higher
Working mode	USB flash drive /Ethernet/Wi-Fi
Printing platform	Flexible printing plate
Leveling method	Automatic leveling

1. Printer Information

1.4 Equipment Size

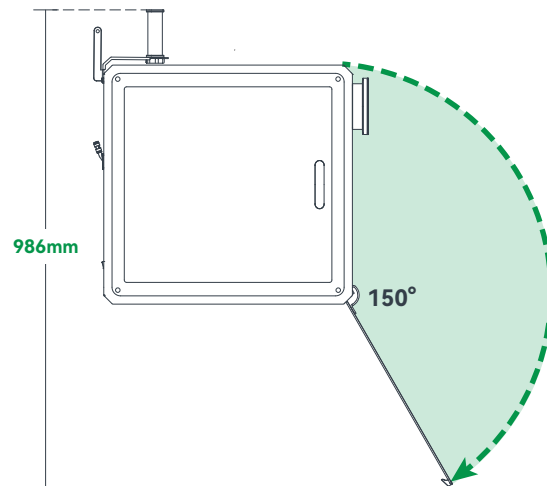
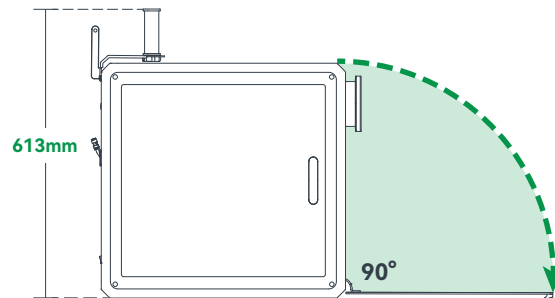
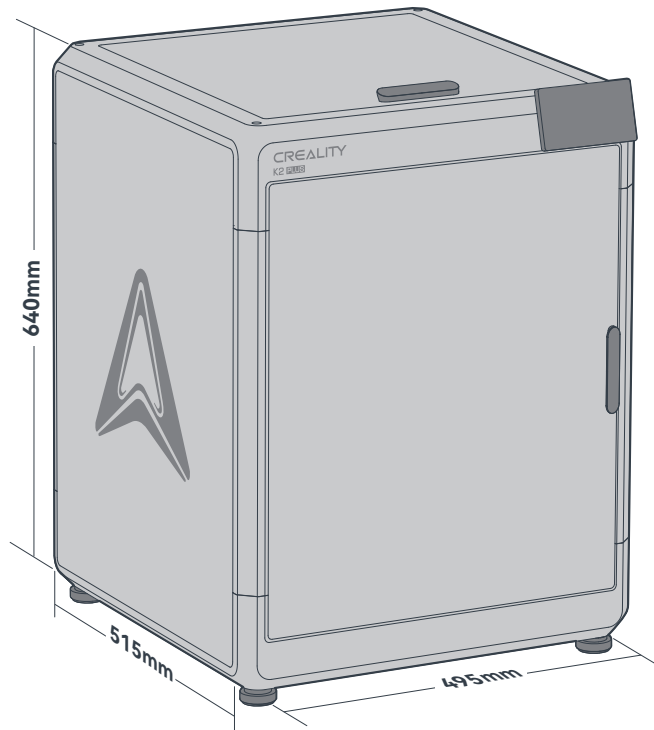

Please ensure that there is at least a 10 cm gap between the machine and the wall.

2. Unboxing

2.1 Remove Screw Rod Holder, Hotbed Locking Screws, Camera cover

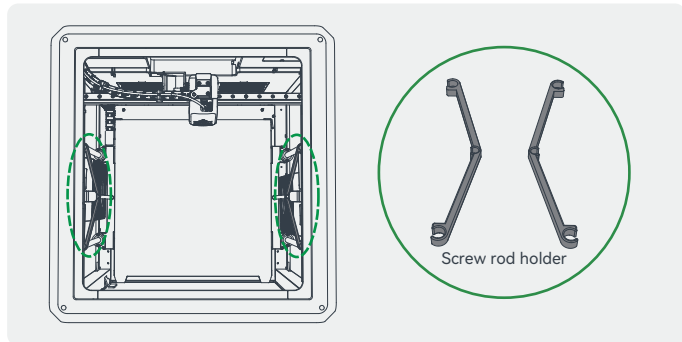

- 1 Remove the left and right screw rod holders.

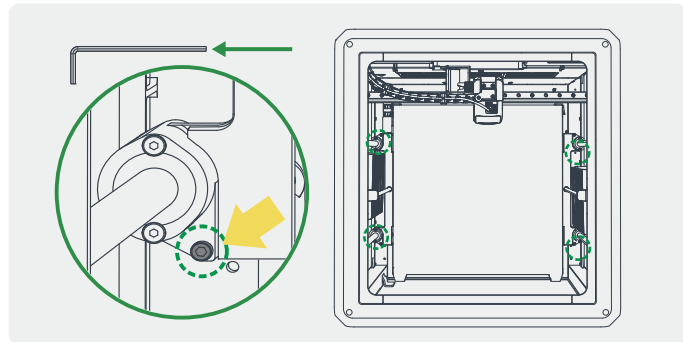

- 2 Use the L-shaped wrench to remove the four hotbed locking screws indicated by the yellow label.

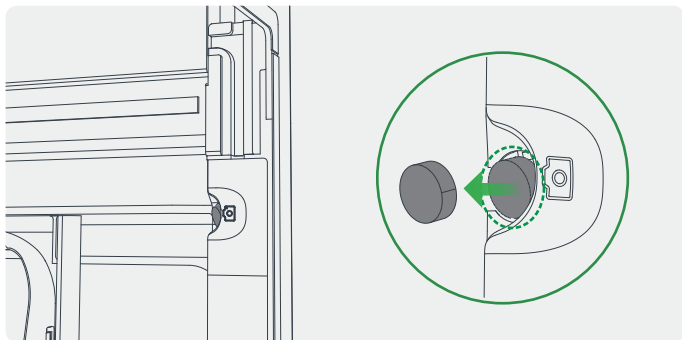

- 3 Remove the camera cover.

2. Unboxing

2.2 Install Accessories

2.2.1 Install Printer Screen

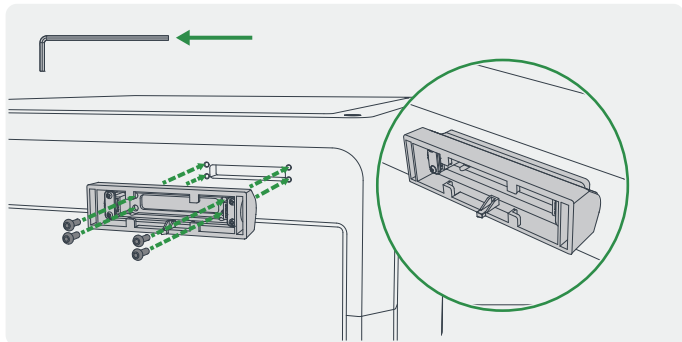

1 Install the screen base.

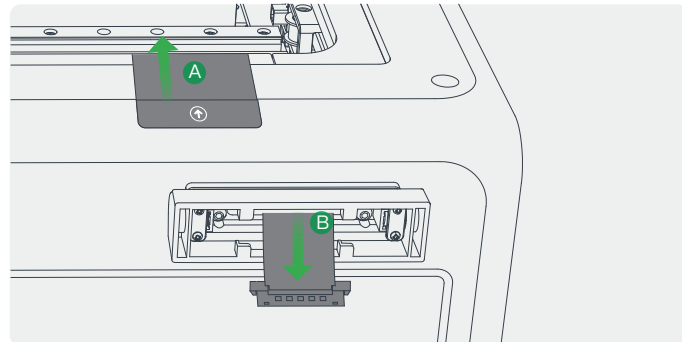

2 A. Tear off the screen flex cable sticker; B. Thread the screen flex cable through the screen base any entrance.

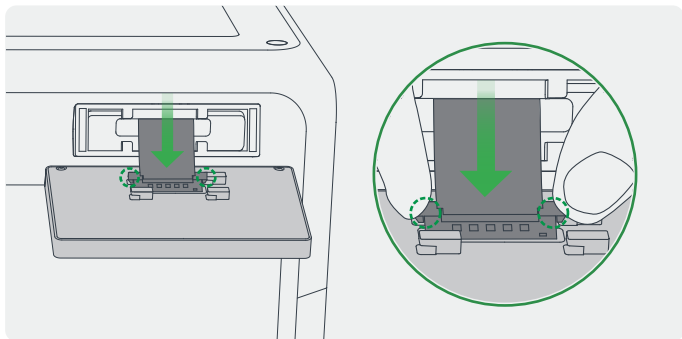

3 Connect the screen cable: Pay attention to the direction shown in the figure and press to connect;

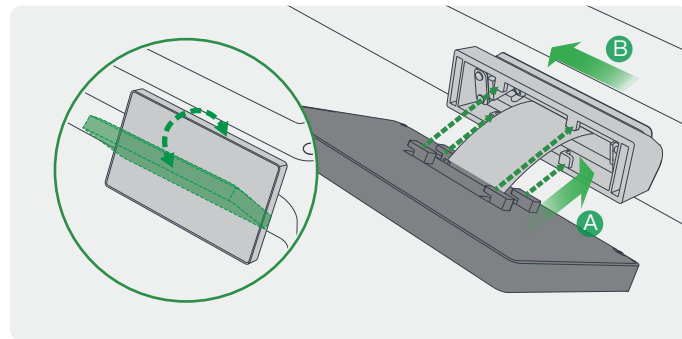

4 Snap the screen into the screen base: A. Align the screen clamping position with the screen base clamping slot; B. Push to the left to lock.

2. Unboxing

2.2.2 Install Spool Holder and PTFE Tube

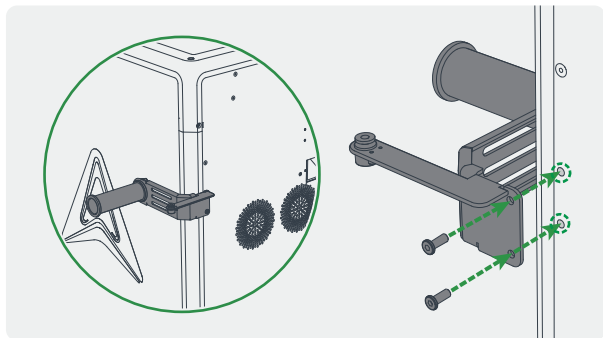

- 1 As shown in the figure, align the material rack with the hole on the back of the machine and tighten it with two material rack screws;

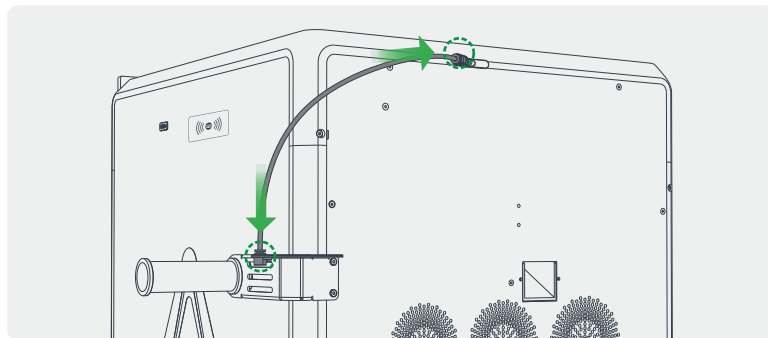

- 2 Connect the Teflon tube: As shown in the figure, connect the two ends of the Teflon tube to the pneumatic joints on the material rack and the machine.

2. Unboxing

2.3 Connecting CFS

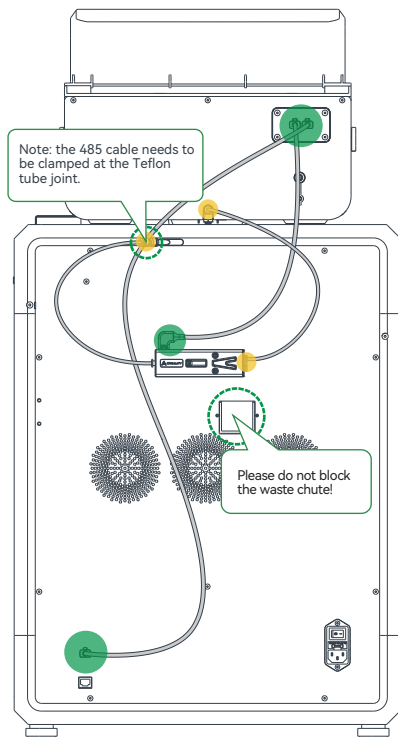

- The green circle is the connection point of the 485 cable;
- The yellow circle is the connection point of the PTFE tube.

2.3.1 Install the filament buffer

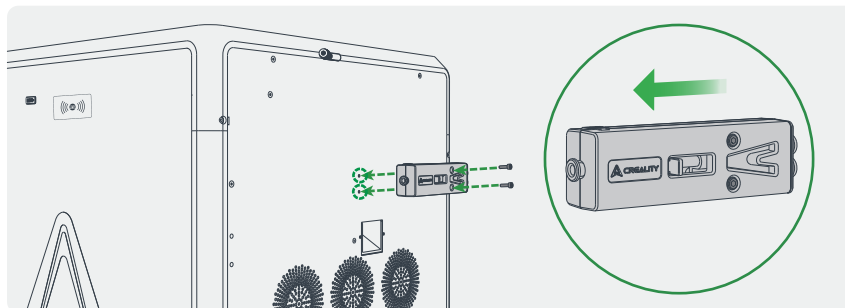

- 1 Install the filament buffer on the back of the printer and tighten it with two buffer screws; pay attention to the direction of the buffer, do not install it in a wrong direction;

2.3.2 Connect the PTFE tube and 485 cable

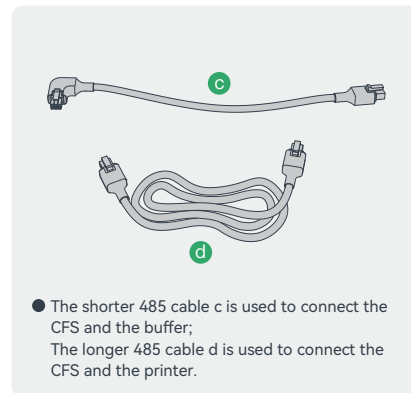
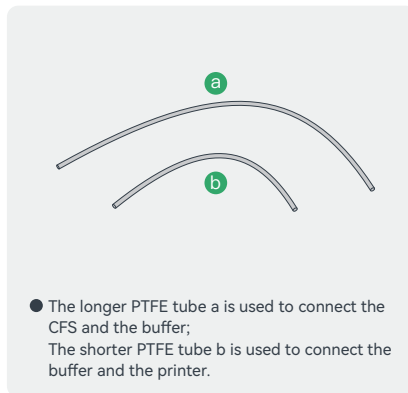

2. Unboxing



- 1 Connect CFS hub outlet and buffer: insert one end of the longer PTFE tube into the CFS hub outlet (position a); insert the other end into the buffer (position b, any of the four holes);

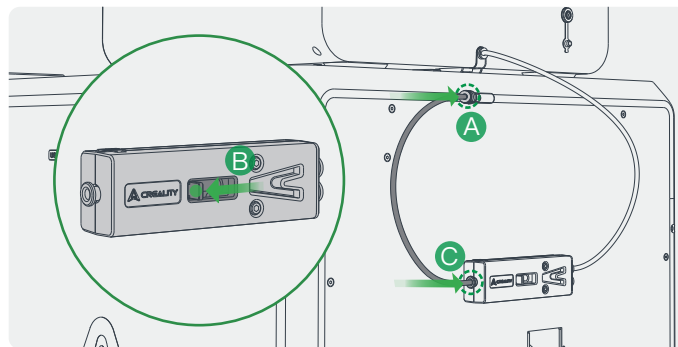

- 2 Connect the buffer and K2 Plus according to steps A, B, and C;

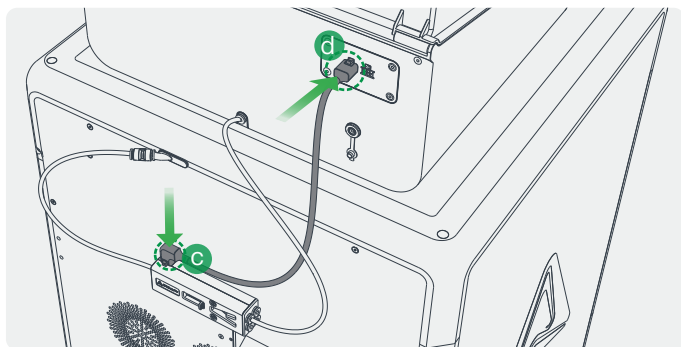

- 3 Connect CFS and buffer Crealty 485 cable: Note that the elbow is inserted into the buffer position c, and the straight head is inserted into the CFS position d (either of the two 485 sockets of CFS);

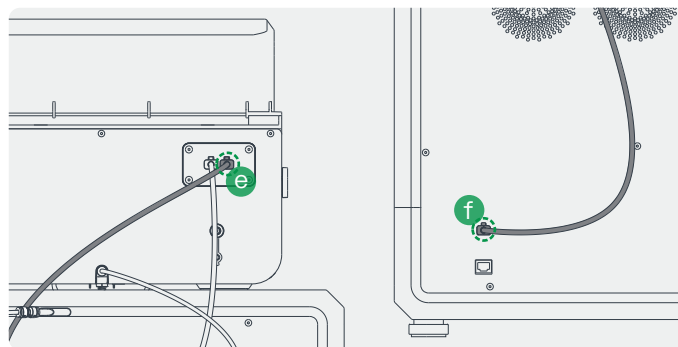

- 4 Connect CFS and K2 Plus Crealty 485 cable: Both ends of this line are 6-pin straight heads, one end is inserted into the CFS position e, and the other end is inserted into the machine interface position f.

2. Unboxing

2.4 Connecting Multiple CFSs for Use

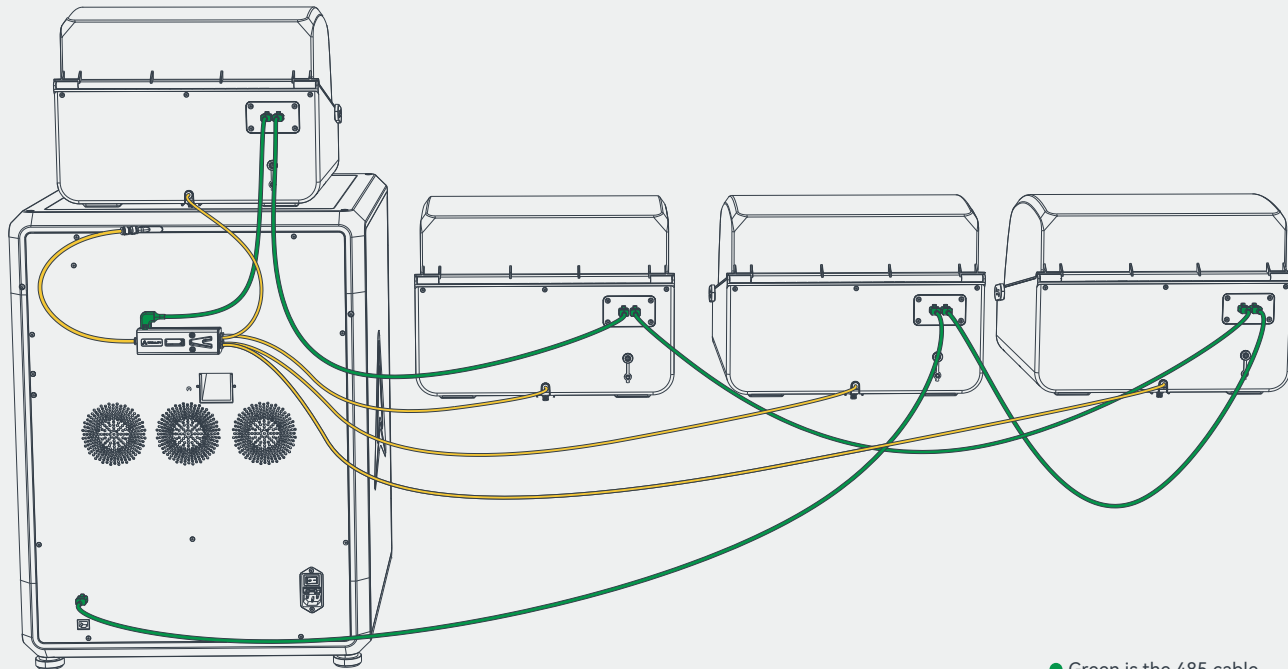

- Green is the 485 cable
- Yellow is the PTFE tube

2. Unboxing

2.5 Power-on Guide

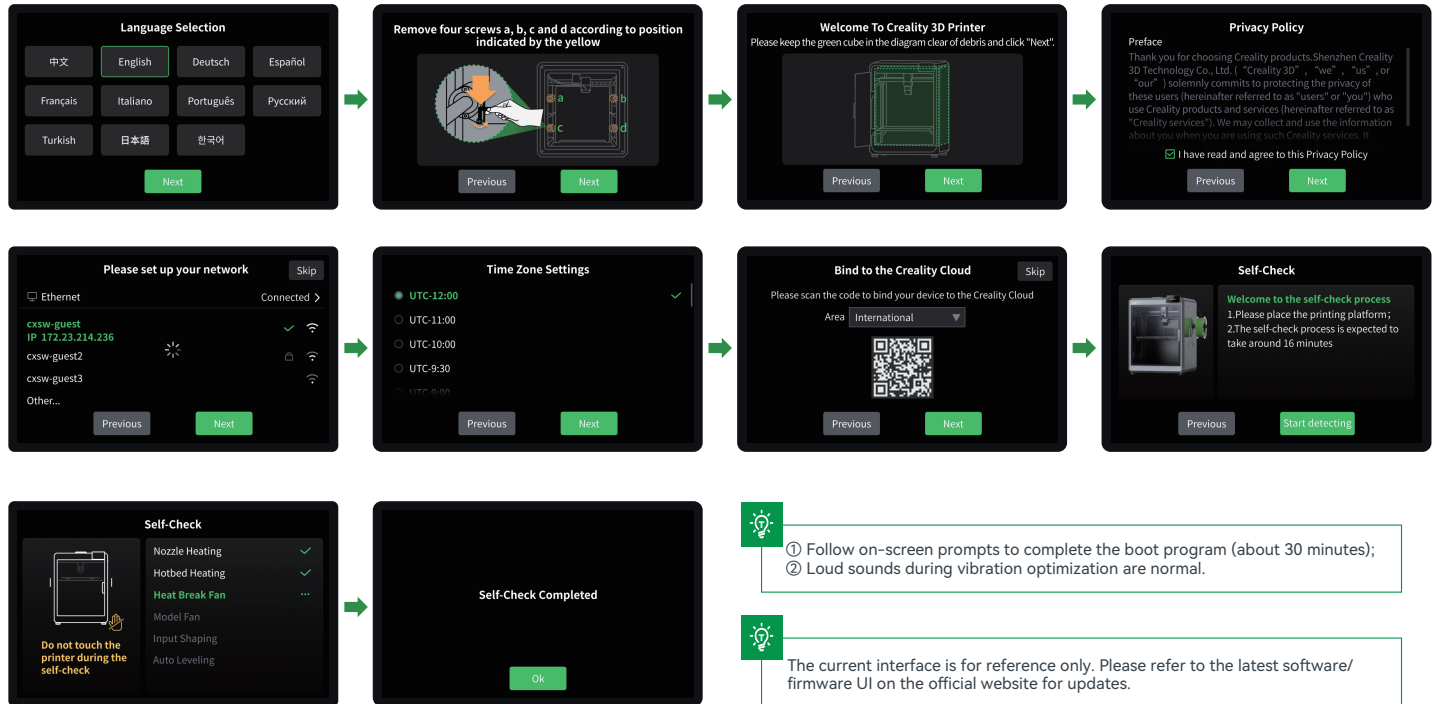

3. Product Usage

3.1 User Interface

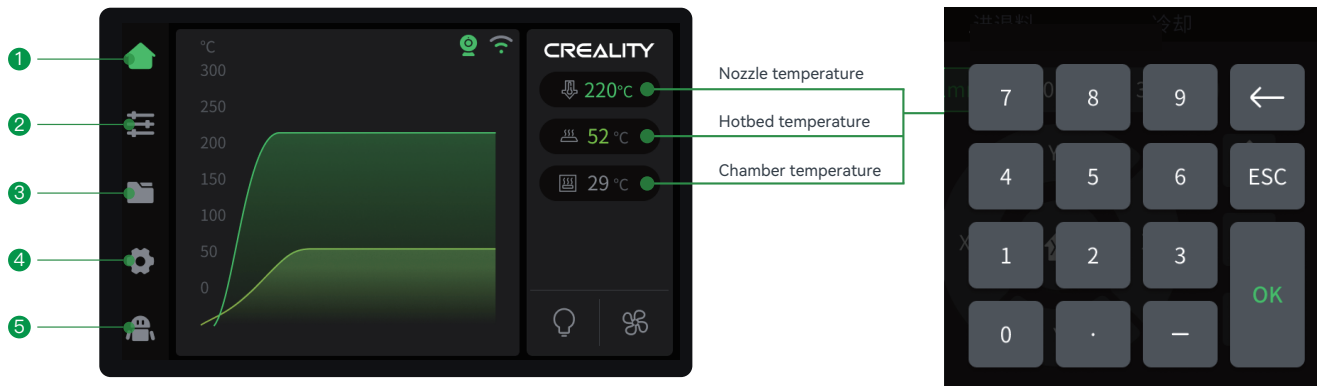

The left side is the navigation bar :

- 1 Home: In idle state, you can view the temperature of each part of the machine; during printing, you can view the model printing progress and other information on this interface;
- 2 Adjustment page: On this page, you can operate the machine to move, load filaments, etc.;
- 3 File page: On this page, you can choose to print files and operate printing;
- 4 Function setting page: You can set network, camera and other functions; you can also view machine information;
- 5 Help page: You can export logs or view machine wiki.



The current interface is for reference only. Please refer to the latest software/firmware UI on the official website for updates.

Parameters can be manually set

3. Product Usage

3.2 Loading Filament From Spool Holder

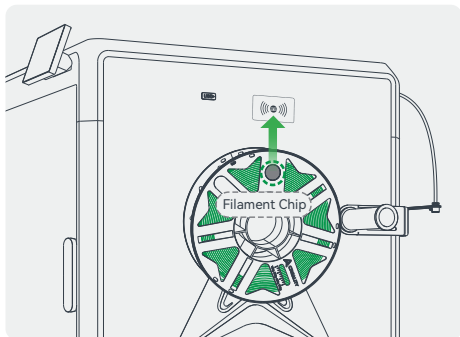

- ❶ If the filaments support RFID recognition, align the chip on the filaments with the RFID recognition position of the machine body to scan the filaments, and the filament information can be automatically set;

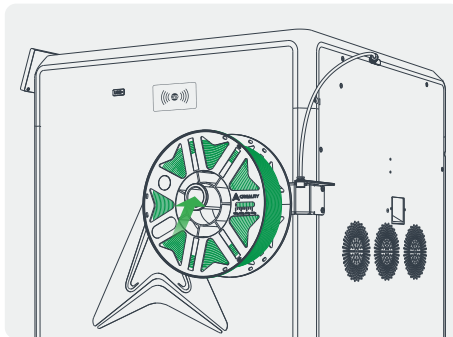

- ❷ Hang the filament on the spool holder;

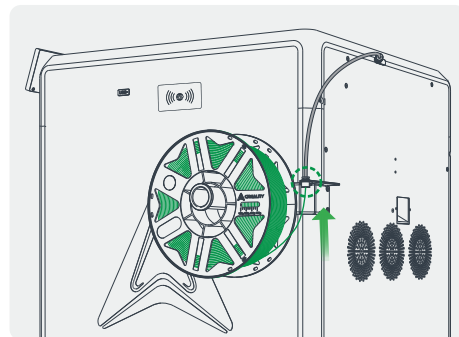

- ❸ Thread the filaments into the Teflon tube and push gently until they cannot be pushed;

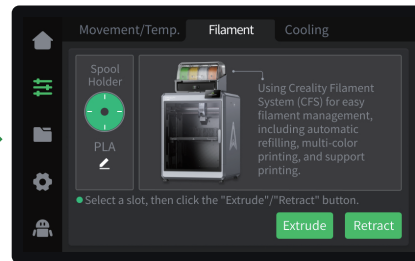
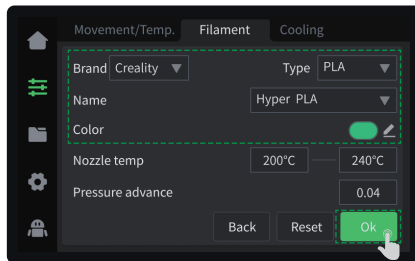
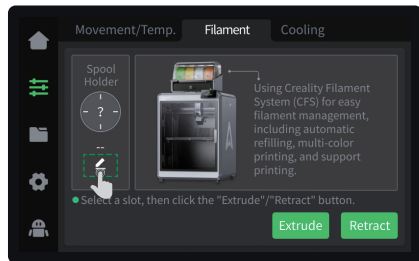

- ❹ If the filaments do not support RFID recognition, you need to manually click on the screen to set the filament information: Adjustment page → Filaments → Edit (as shown below the material rack), set the filament brand-type-name-color respectively, and finally click OK to save the settings;

3. Product Usage

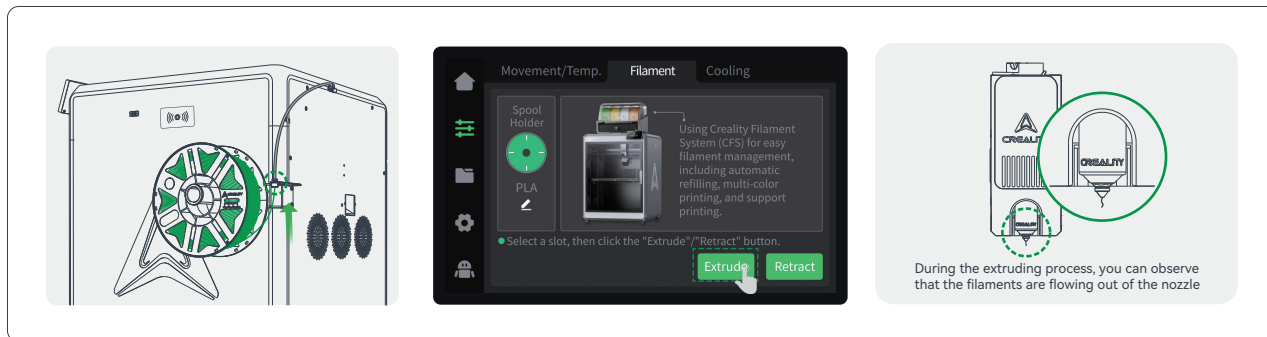

- 5 Extrude: Push the filament gently by hand, and click “Extrude” on the filament interface. The machine will automatically set the current filament temperature, and will automatically extrude the filament after the heating is completed;

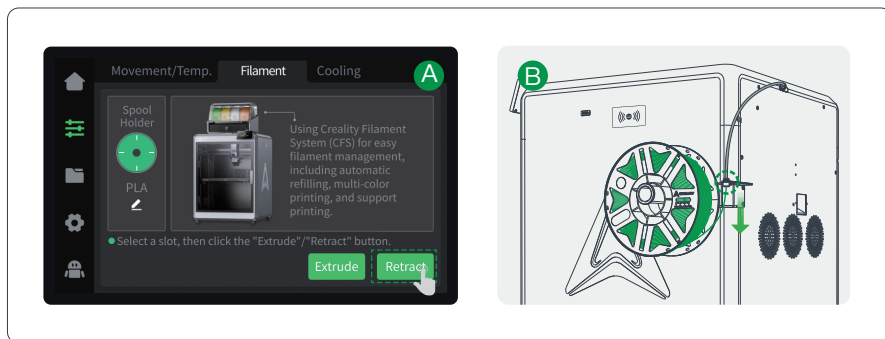

- 6 Retract: A. Click Retract on the filament management page, and the extruder will automatically move to the left front to cut off the filament for retraction;
B. Wait for the retraction to end, and extract the filament from the Teflon tube behind the machine.



During extruding, you can observe whether there is filament flowing out of the nozzle. If no flow-out is observed, you can gently push the filament toward the extruder at the Teflon tube behind the machine, and then click “Extrude” again.



The current interface is for reference only. Please refer to the latest software/firmware UI on the official website for updates.

3. Product Usage

3.3 Loading Filament From CFS



To avoid filament spool getting stuck, do not use cardboard spool with untreated edges or cardboard spool that are deformed as a whole;

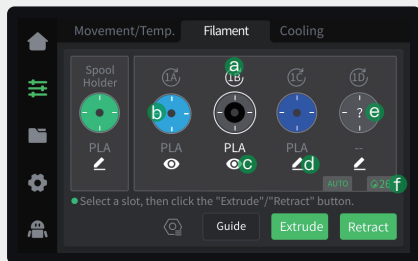

- a is the Refresh RFID button, which can be used to read filament. If the reading is successful, the remaining filament and filament color will be displayed. If the reading fails, the filament editing button will be displayed, and the filament will be displayed as "?";
- b is the empty slot state, displayed as "?", and editing is not supported;
- c means that the RFID filament is read, the eye icon is for viewing filament information, RFID filament only support viewing; if this is RFID and you want to use non-RFID next time, click the pre-loading button, wait for the reading to complete, and then click the filament editing button;
- d is ordinary filament, which support editing;
- e is the state where RFID is not read, the filament display "?". At this time, you need to click the edit button to manually edit the filament information;
- f is the CFS humidity status. Green means the humidity is appropriate, orange means the humidity is slightly higher, and red means the humidity is very high. The desiccant may need to be replaced.

- 1 Introduction to the filament management interface: The filament management page is divided into two parts: the spool holder [left] and the CFS [right]. The code above the filament in the CFS, such as 1A, indicates the slot number;

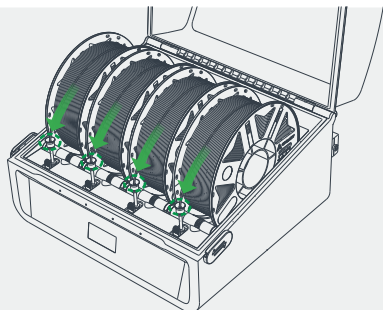
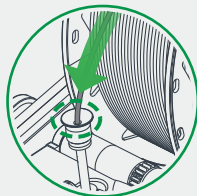

Loading filament: Put the filament into the CFS, align the filament head with the Teflon tube of corresponding silo, push it in gently, and let go after feeling the pulling force. The filament will be automatically loaded.

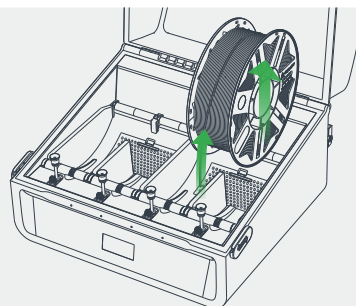

Unloading filament: First, make sure that the filament is not in the extruder, in this case, just pick up the filament and pull it out; if it is in the extruder, click the Retract button first, wait for the filament to return to the CFS, and then take out the filament.

- 2 Load/unload filament.

4. First Use

4.1 Filament Setup

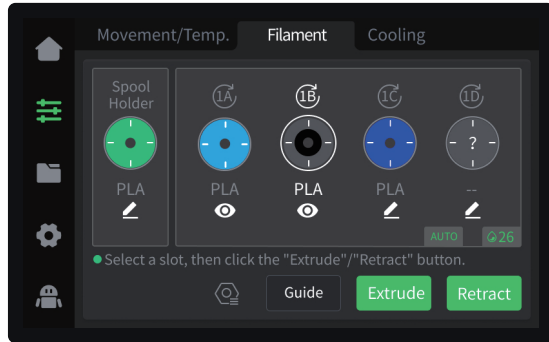

- 1 Put in filament and wait for tightening (RFID filament does not need to be edited, in case of non-RFID filament, "?" will be displayed after reading, and filament needs to be edited manually);

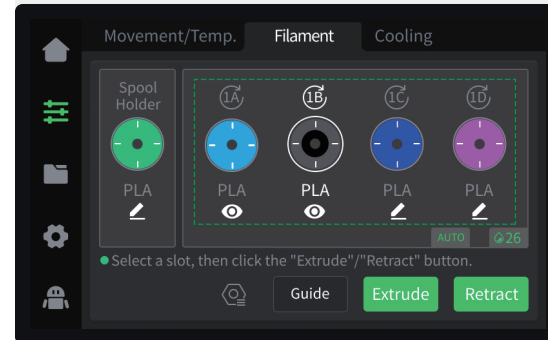
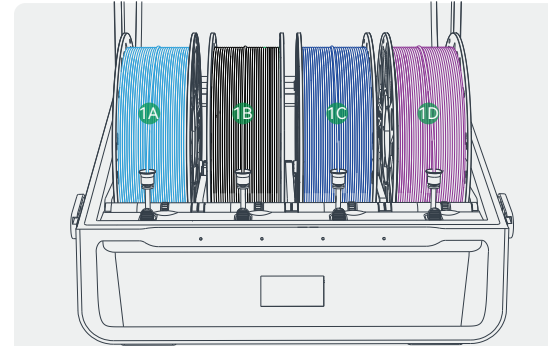

- 2 Check whether the filament information displayed on the screen corresponds to the filament in CFS.



The current interface is for reference only. Please refer to the latest software/firmware UI on the official website for updates.

4. First Use

4.2 Print

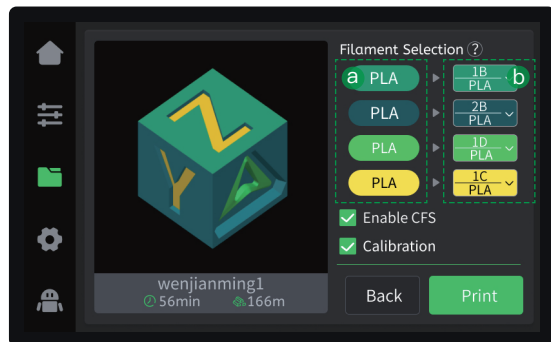

- The area **a** is the color and type of the material contained in the print file. For example, the green background PLA in the figure indicates that green PLA is required;
- The area **b** is the state after the mapping of the print file to the filament bin is completed. For example, there is no green PLA in the filament bin, and the blue PLA is automatically selected;
- When the mapping fails, '--' will be displayed, and the user needs to manually select the material;
- Enabling CFS means printing with CFS filament, otherwise the material rack filament will be used for printing, and the multi-color file will be regarded as a single-color file;
- Checking print calibration will perform automatic leveling, AI calibration and other functions.

- 1 Click the file on the screen, confirm the filament mapping status, and click Print;



- 2 Printing...



The current interface is for reference only. Please refer to the latest software/firmware UI on the official website for updates.

4. First Use

4.3 Crealiti Print Slicing

4.3.1 Software Download and Installation



Log in to the Creality Cloud website to download Creality Print 5.0 or above slicing :
<https://www.crealitycloud.com/software-firmware/software/creality-print> ;

4.3.2 Bind Machine to LAN

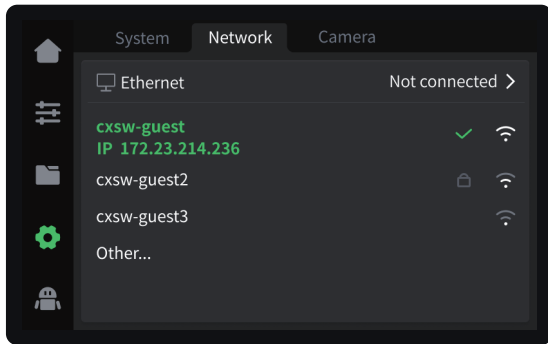

1 Check the machine IP on the machine screen: Settings → Network;

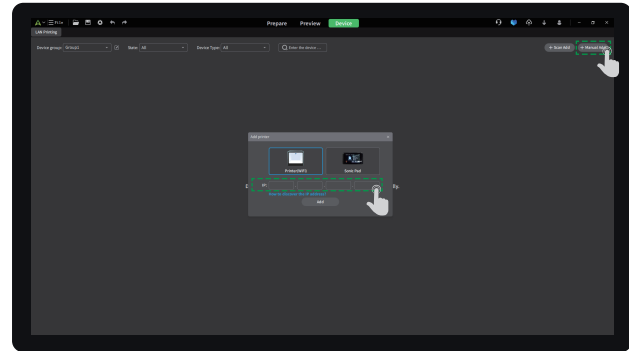

2 Enter the machine IP in the slicing software for binding: Manually add → Enter IP;



The current interface is for reference only. Please refer to the latest software/firmware UI on the official website for updates.

4. First Use

4.3.3 Slice and Send to Print

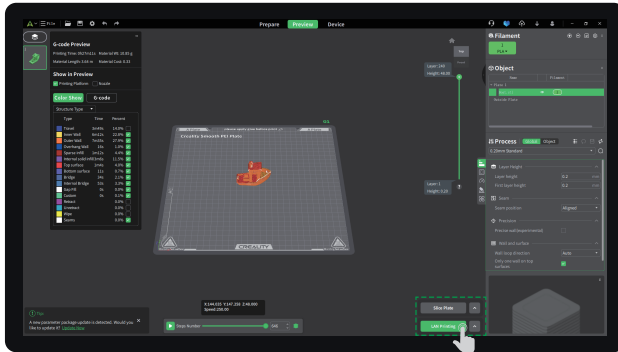

1 Click "Slice Plate", and click "LAN Printing" after slicing is completed;

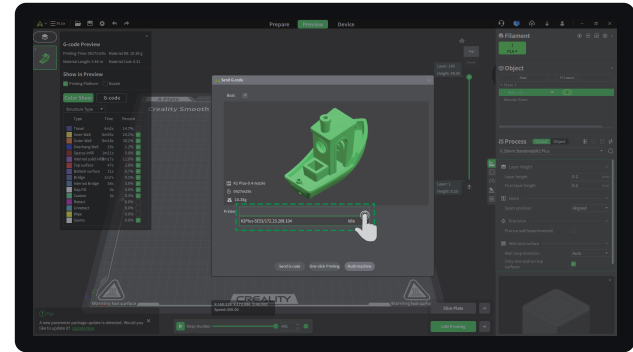

2 Select the bound printer;

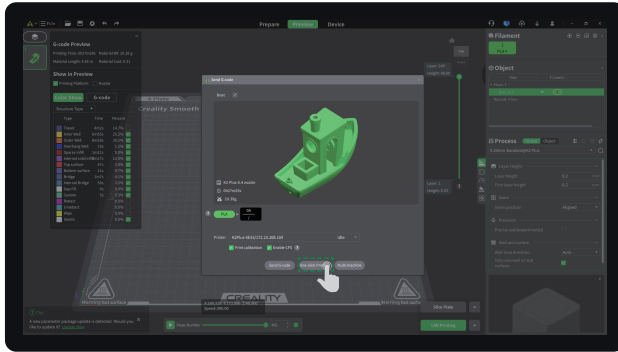

3 Check the machine and filament information, and click "Click to Print".



For more detailed slicing software usage tutorials, please log in to the Creality 3D official Wiki:

<https://wiki.creality.com/en/software/update-released>



The current interface is for reference only. Please refer to the latest software/firmware UI on the official website for updates.

FCC WARNING

This device complies with part 15 of the FCC Rules. Operation is subject to the following two conditions:

(1) this device may not cause harmful interference, and (2) this device must accept any interference received, including interference that may cause undesired operation.

Any changes or modifications not expressly approved by the party responsible for compliance could void the user's authority to operate the equipment.

NOTE: This equipment has been tested and found to comply with the limits for a Class B digital device, pursuant to Part 15 of the FCC Rules. These limits are designed to provide reasonable protection against harmful interference in a residential installation. This equipment generates, uses and can radiate radio frequency energy and, if not installed and used in accordance with the instructions, may cause harmful interference to radio communications.

However, there is no guarantee that interference will not occur in a particular installation.

If this equipment does cause harmful interference to radio or television reception, which can be determined by turning the equipment off and on, the user is encouraged to try to correct the interference by one or more of the following measures:

- Reorient or relocate the receiving antenna.
- Increase the separation between the equipment and receiver.
- Connect the equipment into an outlet on a circuit different from that to which the receiver is connected.
- Consult the dealer or an experienced radio/TV technician for help.

To maintain compliance with FCC's RF Exposure guidelines, This equipment should be installed and operated with minimum distance between 20cm the radiator your body: Use only the supplied antenna.

Due to the differences between different machine models, the actual objects and the images can differ. Please refer to the actual machine. The final explanation rights shall be reserved by Shenzhen Creality 3D Technology Co., Ltd.



SHENZHEN CREALITY 3D TECHNOLOGY CO., LTD.

18th Floor, JinXiuHongDu Building, Meilong Road, Xinniu Community,
Minzhi Street, Longhua District, Shenzhen City, China.

Official Website: www.creality.com

Tel: +86 755-8523 4565

E-mail: cs@creality.com

